



Count on it.

Operator's Manual

21in Commercial Lawn Mower

Model No. 22155—Serial No. 290000001 and Up

Model No. 22156—Serial No. 290000001 and Up



G005980

Warning

CALIFORNIA Proposition 65 Warning

The engine exhaust from this product contains chemicals known to the State of California to cause cancer, birth defects, or other reproductive harm.

Important: This engine is not equipped with a spark arrester muffler. It is a violation of California Public Resource Code Section 4442 to use or operate the engine on any forest-covered, brush-covered, or grass-covered land. Other states or federal areas may have similar laws.

This spark ignition system complies with Canadian ICES-002.

The enclosed *Engine Owner's Manual* is supplied for information regarding the US Environmental Protection Agency (EPA) and the California Emission Control Regulation of emission systems, maintenance, and warranty. Replacements may be ordered through the engine manufacturer.

Introduction

Read this information carefully to learn how to operate and maintain your product properly and to avoid injury and product damage. You are responsible for operating the product properly and safely.

You may contact Toro directly at www.Toro.com for product and accessory information, help finding a dealer, or to register your product.

Whenever you need service, genuine Toro parts, or additional information, contact an Authorized Service Dealer or Toro Customer Service and have the model and serial numbers of your product ready. Figure 1 identifies the location of the model and serial numbers on the product. Write the numbers in the space provided.

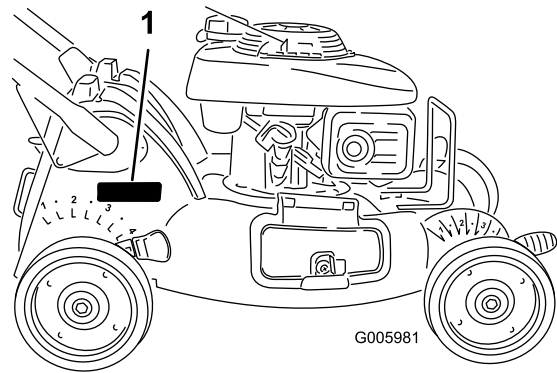

Figure 1

1. Model and serial number location

Model No. _____

Serial No. _____

This manual identifies potential hazards and has safety messages identified by the safety alert symbol (Figure 2), which signals a hazard that may cause serious injury or death if you do not follow the recommended precautions.



Figure 2

1. Safety alert symbol

This manual uses 2 words to highlight information. **Important** calls attention to special mechanical information and **Note** emphasizes general information worthy of special attention.

Contents

Introduction.....	2
Safety	3
General Operation	3
Slope Operation	4
Children	4
Service	4
Safety and Instructional Decals	5
Setup.....	6
1 Installing the Handle.....	6
2 Filling the Engine with Oil	8
3 Install the Mulch Plug or Grass Bag	9
Product Overview	10
Controls	10
Operation.....	11
Checking the Engine Oil Level.....	11
Filling the Fuel Tank with Gasoline	11
Starting the Engine.....	11
Stopping the Engine	13
Operating the Self-propel Drive.....	13
Adjusting the Cutting Height	14
Mulching the Clippings.....	14
Bagging the Clippings.....	14
Side-discharging the Clippings	16
Operating Tips	17
Maintenance.....	18
Recommended Maintenance Schedule(s)	18
Premaintenance Procedures.....	18
Preparing for Maintenance	18
Engine Maintenance.....	19
Servicing the Air Cleaner	19
Changing the Engine Oil	19
Servicing the Spark Plug	20
Drive System Maintenance	21
Adjusting the Self-propel Drive.....	21
Blade Maintenance	21
Maintaining the Cutting Blade.....	21
Cleaning	22
Cleaning the Mower Housing.....	22
Storage.....	23
Preparing the Fuel System.....	23
Preparing the Engine.....	23
General Information	23
Removing the Lawn Mower from Storage.....	23
Troubleshooting.....	24

Safety

This lawn mower meets or exceeds the CPSC blade safety requirements for walk-behind rotary lawn mowers and the B71.1 specifications of the American National Standards Institute in effect at the time of production.

Read and understand the contents of this manual before you start the engine.

The safety alert symbol (Figure 2) is used to alert you to potential personal injury hazards. Obey all safety messages that follow this symbol to avoid possible injury or death. Improperly using or maintaining this mower could result in injury or death. To reduce this potential, comply with the following safety instructions.

The following instructions have been adapted from the ANSI/OPEI standard B71.1-2003.

This cutting machine is capable of amputating hands and feet and of throwing objects. Failure to observe the following safety instructions could result in serious injury or death.

General Operation

- Read, understand, and follow all instructions on the machine and in the manual(s) before starting.
- Do not put hands or feet near or under the machine. Keep clear of the discharge opening at all times.
- Only allow responsible adults, who are familiar with the instructions, to operate this machine.
- Clear the area of objects such as rocks, wire, toys, etc., which could be thrown by the blade. Stay behind the handle when the engine is running.
- Be sure the area is clear of bystanders before operating. Stop machine if anyone enters the area.
- Do not operate machine barefooted or while wearing sandals. Always wear substantial footwear.
- Do not pull machine backward unless absolutely necessary. Always look down and behind before and while moving backward.
- Never direct discharged material toward anyone. Avoid discharging material against a wall or obstruction. Material may ricochet back toward the operator. Stop the blade when crossing gravel surfaces.
- Do not operate machine without the entire grass catcher, discharge guard, rear guard, or other safety protective devices in place and working.
- Never leave a running machine unattended.
- Stop the engine and wait until the blade comes to a complete stop before cleaning the machine,

removing grass catcher, or unclogging the discharge guard.

- Operate machine only in daylight or good artificial light.
- Do not operate machine while under the influence of alcohol or drugs.
- Never operate mower in wet grass. Always be sure of your footing; walk; never run.
- Disengage the drive system, if so equipped, before starting the engine.
- If the machine should start to vibrate abnormally, stop the engine and check for the cause immediately. Vibration is generally a warning of trouble.
- Always wear eye protection when operating machine.
- See manufacturer's instructions for proper operation and installation of accessories. Only use accessories approved by the manufacturer.

Slope Operation

Slopes are a major factor related to slip and fall accidents, which can result in severe injury. Operation on all slopes require extra caution. If you feel uneasy on a slope, do not mow it.

- Mow across the face of slopes; never up and down. Exercise extreme caution when changing direction on slopes.
- Watch for holes, ruts, bumps, rocks, or other hidden objects. Uneven terrain could cause a slip and fall accident. Tall grass can hide obstacles.
- Do not mow on wet grass or excessively steep slopes. Poor footing could cause a slip and fall accident.
- Do not mow near drop-offs, ditches, or embankments. You could lose your footing or balance.

Children

Tragic accidents can occur if the operator is not alert to the presence of children. Children are often attracted to the machine and the mowing activity. **Never** assume that children will remain where you last saw them.

- Keep children out of the mowing area and under the watchful care of a responsible adult other than the operator.
- Be alert and turn mower off if a child enters the area.
- Never allow children to operate the machine.
- Use extra care when approaching blind corners, shrubs, trees, or other objects that may block your view of a child.

Service

Safe Handling of Gasoline

To avoid personal injury or property damage, use extreme care in handling gasoline. Gasoline is extremely flammable and the vapors are explosive.

- Extinguish all cigarettes, cigars, pipes, and other sources of ignition.
- Use only an approved gasoline container.
- Never remove gas cap or add fuel with the engine running. Allow engine to cool before refueling.
- Never refuel the machine indoors.
- Never store the machine or fuel container where there is an open flame, spark, or pilot light such as on a water heater or on other appliances.
- Never fill containers inside a vehicle or on a truck or trailer bed with a plastic liner. Always place containers on the ground away from your vehicle before filling.
- Remove gas-powered equipment from the truck or trailer and refuel it on the ground. If this is not possible, then refuel such equipment with a portable container, rather than from a gasoline dispenser nozzle.
- Keep the nozzle in contact with the rim of the fuel tank or container opening at all times until fueling is complete. Do not use a nozzle lock-open device.
- If fuel is spilled on clothing, change clothing immediately.
- Never overfill fuel tank. Replace gas cap and tighten securely.



Exhaust contains carbon monoxide, an odorless, deadly poison that can kill you.

Do not run the engine indoors or in an enclosed area.

General Service

- Never operate machine in a closed area.
- Keep all nuts and bolts tight to be sure the equipment is in safe working condition.
- Never tamper with safety devices. Check their proper operation regularly.
- Keep machine free of grass, leaves, or other debris build-up. Clean up oil or fuel spillage and remove

any fuel-soaked debris. Allow machine to cool before storing.

- If you strike a foreign object, stop and inspect the machine. Repair, if necessary, before starting.
- Never make any adjustments or repairs with the engine running. Disconnect the spark plug wire and ground against engine to prevent unintended starting.

- Check grass catcher components and the discharge guard frequently and replace with manufacturer's recommended parts, when necessary.
- Mower blades are sharp. Wrap the blade or wear gloves, and use extra caution when servicing them.
- Do not change the engine governor setting or overspeed the engine.
- Maintain or replace safety and instructional labels, as necessary.

Safety and Instructional Decals



Safety decals and instructions are easily visible to the operator and are located near any area of potential danger. Replace any decal that is damaged or lost.

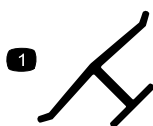

Manufacturer's Mark

1. Indicates the blade is identified as a part from the original machine manufacturer.

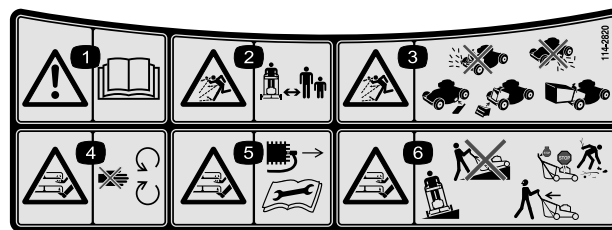

114-2820

1. Warning—read the *Operator's Manual*.
2. Thrown object hazard—keep bystanders a safe distance from the machine.
3. Thrown object hazard—do not operate the mower without the rear discharge plug or bag in place; do not operate the mower without the side discharge cover or deflector in place.
4. Cutting/dismemberment hazard of hand or foot, mower blade—stay away from moving parts.
5. Cutting/dismemberment hazard of hand or foot, mower blade—remove the ignition key and read the instructions before servicing or performing maintenance.
6. Cutting/dismemberment hazard of hand or foot, mower blade—do not operate up and down slopes; operate side to side on slopes; stop the engine before leaving the operating position; and look behind you when backing up.



94-8072

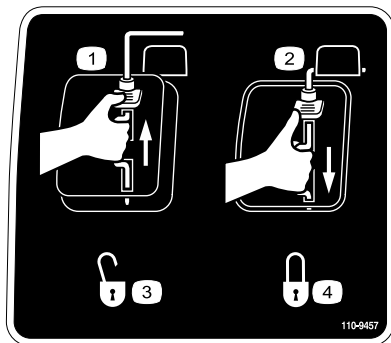

110-9457

1. Engine switch Off
2. Engine switch On
3. Unlocked
4. Locked

Setup

Loose Parts

Use the chart below to verify that all parts have been shipped.

Procedure	Description	Qty.	Use
1	Bolt (1/2 x 1-1/2 inches) Curved washer Spacer Locknut (1/2 inch)	4 2 2 4	Install the handle.
2	SAE 30W detergent oil with an API service classification of SH, SJ, SL, or higher (not supplied with the mower).	20 oz. (0.55 l)	Fill the engine with oil.
3	No parts required	-	Install the mulch plug or grass bag.

1

Installing the Handle

Parts needed for this procedure:

4	Bolt (1/2 x 1-1/2 inches)
2	Curved washer
2	Spacer
4	Locknut (1/2 inch)

Procedure

1. Remove the two screws that hold the back cover in place and remove the back cover (Figure 3).

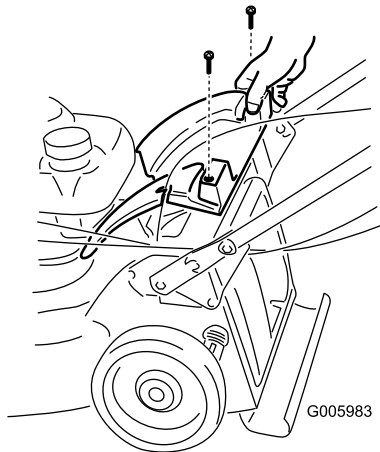

Figure 3

2. Attach the handle to the mower housing (Figure 4) using the 4 bolts, 4 locknuts, 2 spacers, and 2 curved washers in the loose parts bag.

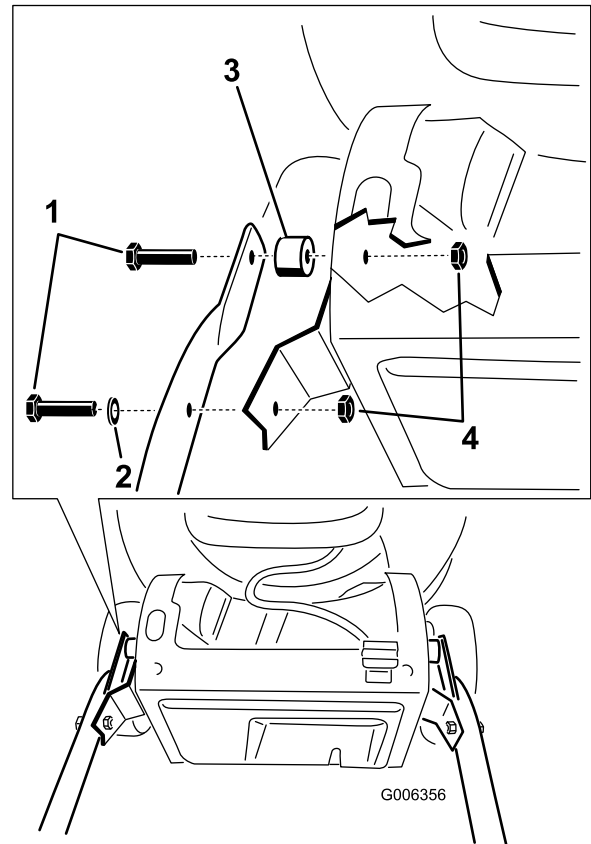

Figure 4

- | | |
|----------------------------------|---------------------------|
| 1. Bolt (1/2 x 1-1/2 inches) (4) | 3. Spacer (2) |
| 2. Curved washer (2) | 4. Locknut (1/2 inch) (4) |

Note: You can set the handle height in one of two positions (Figure 5). Set the handle to a height that is comfortable for you.

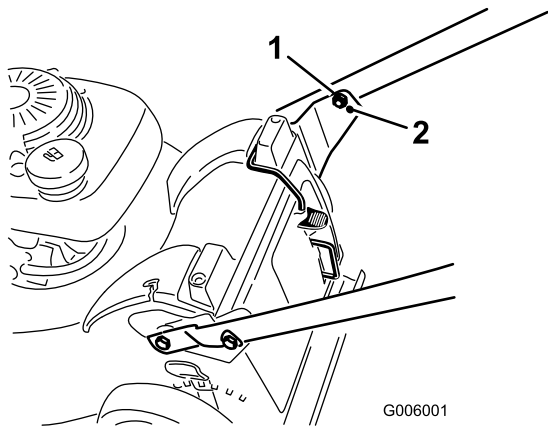

Figure 5

1. Higher handle position
2. Lower handle position

Note: Torque all bolts to 120 in-lb (13.6 N·m).

3. Route the blade brake cable around the outside of the handle and attach the cable end (Figure 6).

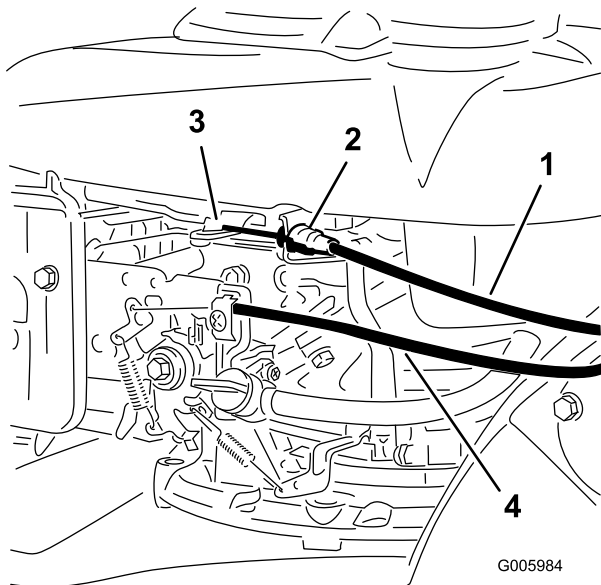

Figure 6

1. Blade brake cable
2. Insert cable jacket end here
3. Attach cable Z-fitting end here
4. Throttle cable

4. Route the self-propel drive cable around the outside of the handle, thread the cable through the opening on the left hand side of the housing, and attach the cable end (Figure 7).

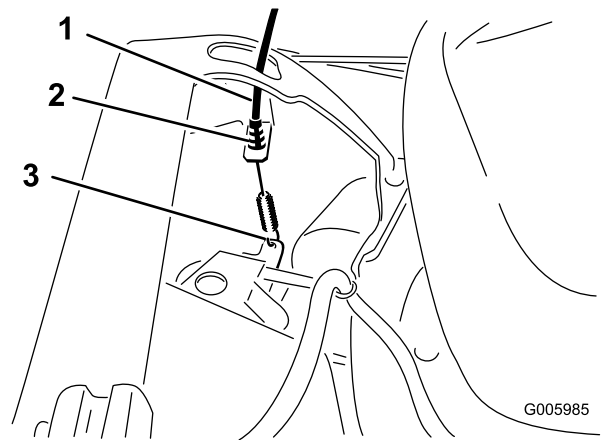

Figure 7

1. Self-propel drive cable
2. Insert cable jacket end here
3. Attach cable end here

5. Ensure that the self-propel drive is properly adjusted. Refer to Adjusting the Self-propel Drive in the Maintenance section.
6. Route the throttle cable around the outside of the handle, insert the cable jacket in the cable clamp, and attach the cable end to the throttle lever on the engine (Figure 6 and Figure 8).

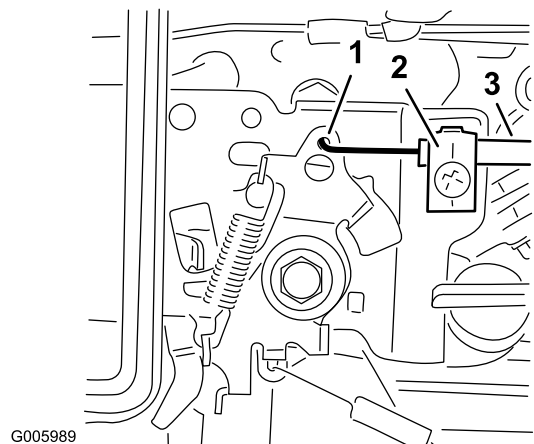

Figure 8

1. Attach cable end here
2. Cable clamp
3. Throttle cable

7. Adjust the throttle cable by doing the following:
 - A. Set the throttle control to the Fast position (Figure 9).

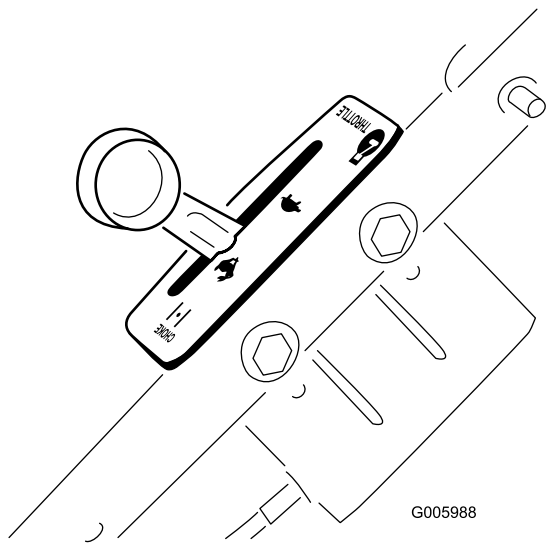

Figure 9

- B. Remove the air cleaner cover to see the throttle on the engine more easily (Figure 10).

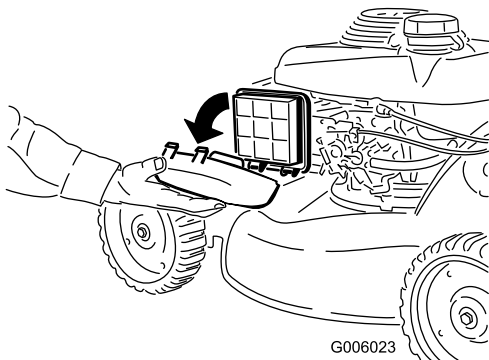

Figure 10

- C. Move the throttle lever on the engine until the throttle lever just touches the choke lever (Figure 11).

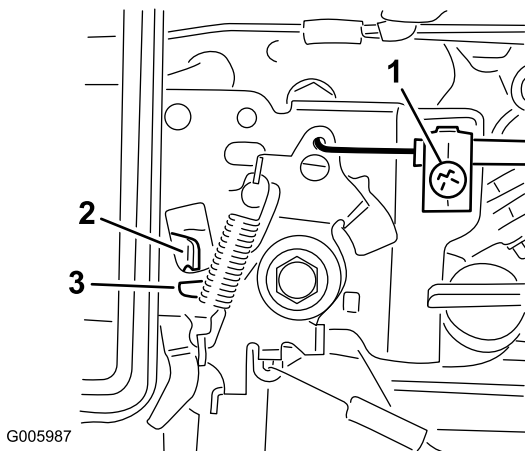

Figure 11

1. Set screw
2. Choke lever
3. Throttle lever

D. Tighten the set screw (Figure 11).

E. Install the air cleaner cover.

8. Install the back cover with the two screws you removed in step 1.

2

Filling the Engine with Oil

Parts needed for this procedure:

20 oz. (0.55 l)	SAE 30W detergent oil with an API service classification of SH, SJ, SL, or higher (not supplied with the mower).
--------------------	--

Procedure

Important: Your mower *does not* come with oil in the engine.

1. Remove the dipstick (Figure 12).

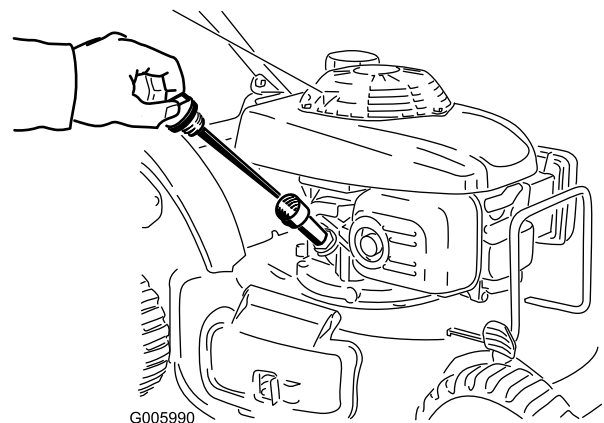

Figure 12

2. **Slowly** pour oil into the oil fill tube, periodically checking the level with the dipstick, until the dipstick indicates that the engine is full as illustrated in Figure 12. **Do not overfill.** (Max. fill: 20 oz. (0.55 l), **type: SAE 30W detergent oil** with an API service classification of SH, SJ, SL, or higher.)

Note: If you overfill the engine, pour some oil out of it as directed in Changing the Engine Oil.

3. Install the dipstick securely.

Important: *Change the engine oil after the first 5 operating hours; change it yearly thereafter. Refer to Changing the Engine Oil.*

3

Install the Mulch Plug or Grass Bag

No Parts Required

Procedure

You must correctly install the mulch plug (for mulching or side-discharging) or grass bag (for bagging) or **the engine will not start**.

The mower has a safety switch, located at the bottom of a channel on the top, right rear of the mower, that prevents the mower from operating without a mulch plug or grass bag. This prevents the mower from throwing debris at the operator through the rear chute.

For the switch to detect the presence of the mulch plug, the top of the mulch plug lever must **lie fully** in the **bottom of the channel** (Figure 13).

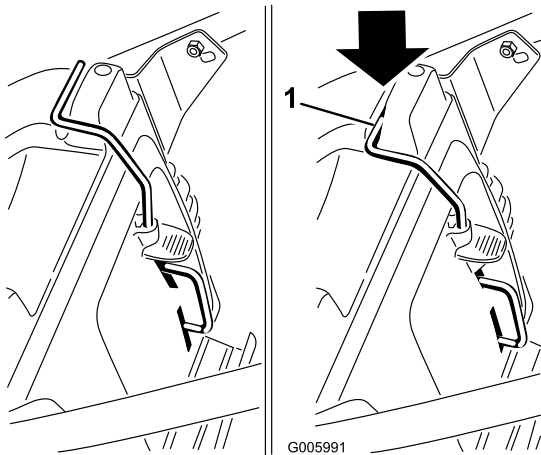

Figure 13

1. Top of mulch plug lever in switch channel

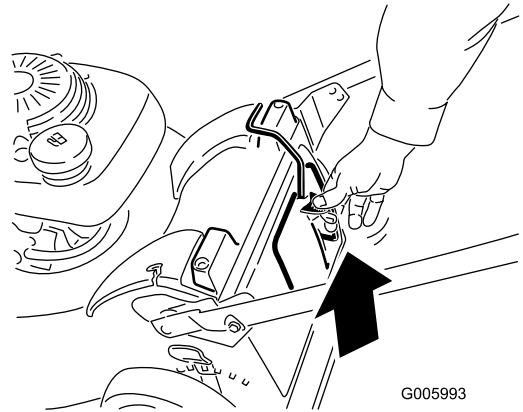
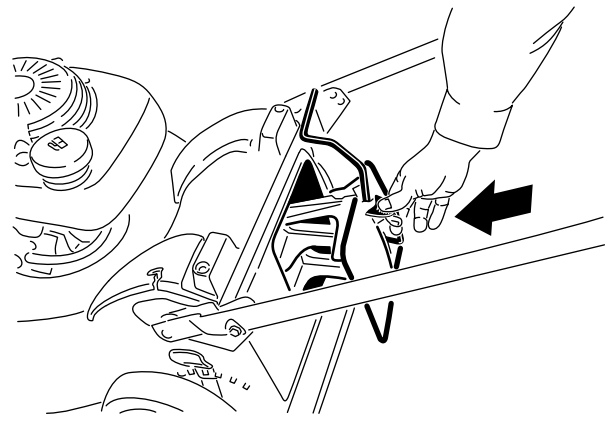

Figure 14

2. Squeeze the button on the lever with your thumb and fully insert the mulch plug into the opening (Figure 14).
3. Release the button on the lever and ensure that the top of the lever is lies fully in the switch channel. **If the top of the lever is not in the switch channel, your mower will not start!**

Note: If the lever does not latch properly, disconnect the wire from the spark plug and check for and remove any debris buildup in the tunnel.

1. Insert the mulch plug into the mower, if it isn't already installed (Figure 14).

Product Overview

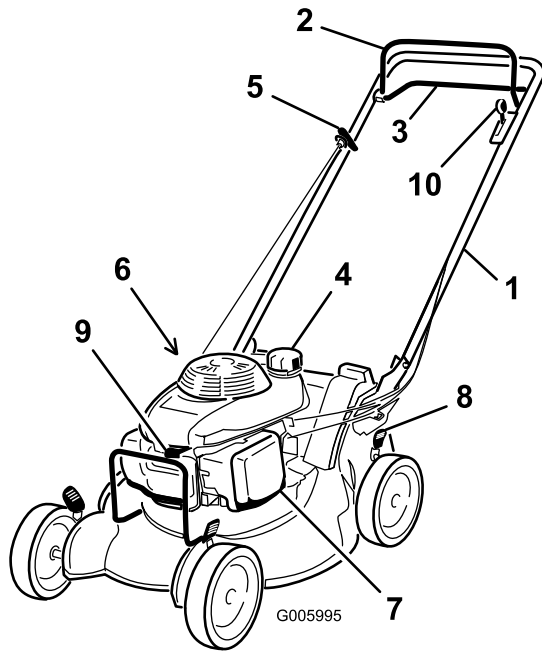

Figure 15

- | | |
|--------------------------|-----------------------------|
| 1. Handle | 6. Oil fill/dipstick |
| 2. Blade control bar | 7. Air filter |
| 3. Self-propel drive bar | 8. Cutting height lever (4) |
| 4. Fuel tank | 9. Spark plug |
| 5. Starter handle | 10. Throttle control lever |

Controls

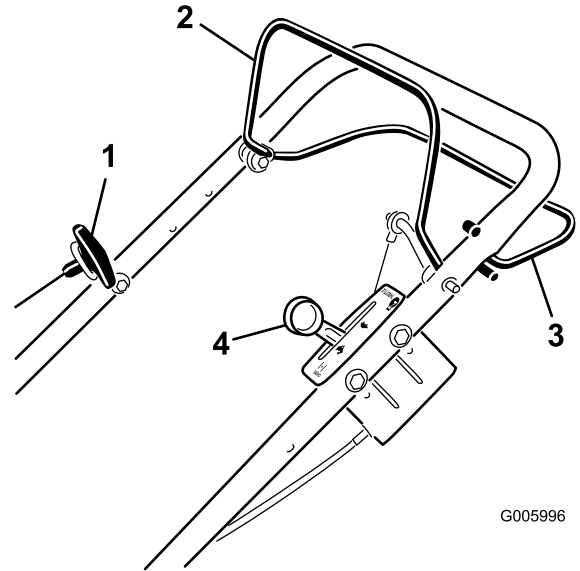

Figure 17

- | | |
|------------------------|---------------------------|
| 1. Recoil start handle | 3. Self-propel drive bar |
| 2. Blade control bar | 4. Throttle control lever |

The throttle settings are shown in (Figure 18).

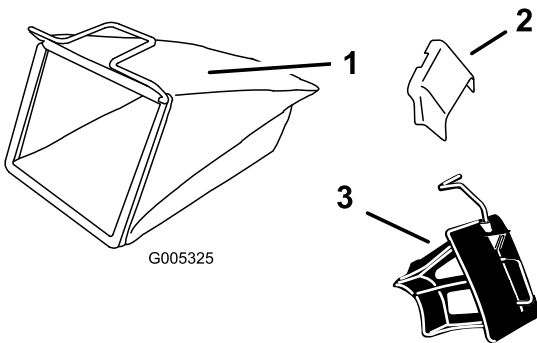

Figure 16

- | | |
|-------------------------|---------------------------|
| 1. Grass bag | 3. Mulch plug (installed) |
| 2. Side discharge chute | |

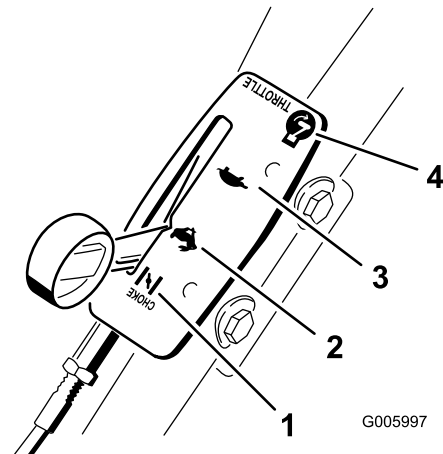

Figure 18

- | | |
|----------|---------|
| 1. Choke | 3. Slow |
| 2. Fast | 4. Stop |

Operation

Note: Determine the left and right sides of the machine from the normal operating position.

Checking the Engine Oil Level

Service Interval: Before each use or daily

1. Remove the dipstick, wipe it clean, and insert it into the oil filler neck, **but do not screw it in** (Figure 19).

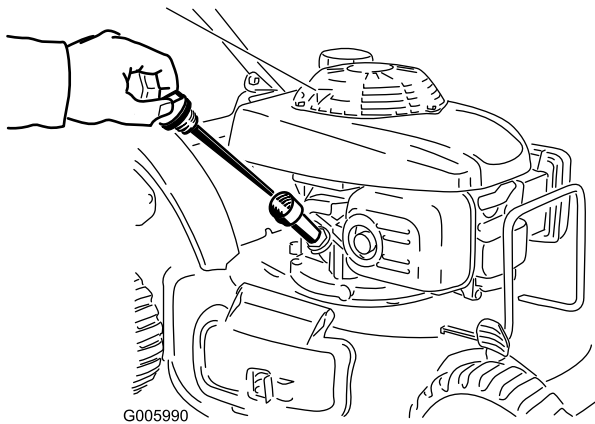

Figure 19

2. Remove the dipstick and check the oil level (Figure 19).

If there is no oil on the dipstick, **slowly** pour oil into the oil fill tube, periodically checking the level with the dipstick, until the dipstick indicates that the engine is full as illustrated in Figure 19. **Do not overfill.** (Max. fill: 20 oz. (0.55 l), type: SAE 30W detergent oil with an API service classification of SH, SJ, SL, or higher.)

Note: If you overfill the engine, pour some oil out of it as directed in Changing the Engine Oil.

3. Install the dipstick securely.

Filling the Fuel Tank with Gasoline



Gasoline is extremely flammable and explosive. A fire or explosion from gasoline can burn you and others.

- To prevent a static charge from igniting the gasoline, place the container and/or mower directly on the ground before filling, not in a vehicle or on an object.
- Fill the tank outdoors when the engine is cold. Wipe up spills.
- Do not handle gasoline when smoking or around an open flame or sparks.
- Store gasoline in an approved fuel container, out of the reach of children.

Fill the fuel tank with fresh unleaded regular gasoline from a major name-brand service station (Figure 20).

Important: To reduce starting problems, add fuel stabilizer to the fuel all season, mixing it with gasoline less than 30 days old.

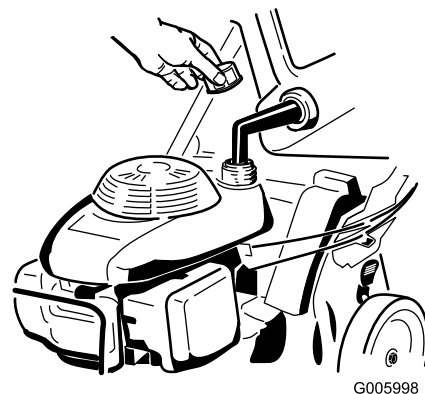

Figure 20

Starting the Engine

Important: The mower has a safety switch that prevents you from starting the mower unless you first install the mulch plug or the grass bag securely on the mower.

1. Install the mulch plug (Figure 21) or the grass bag (Figure 22) on the mower.

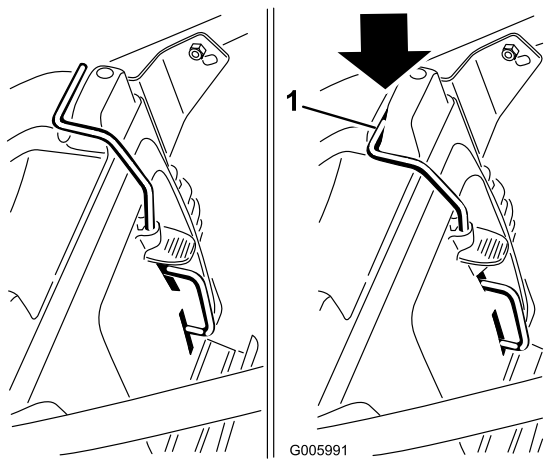

Figure 21

1. Top of mulch plug lever in switch channel

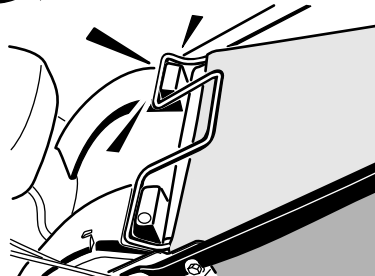
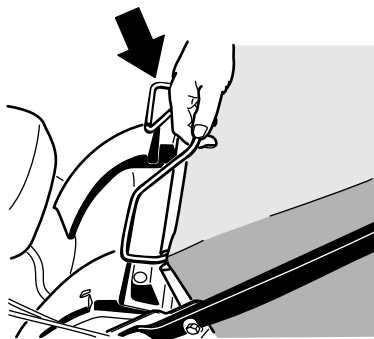

Figure 22

2. Turn the fuel valve lever to the On position (Figure 23).

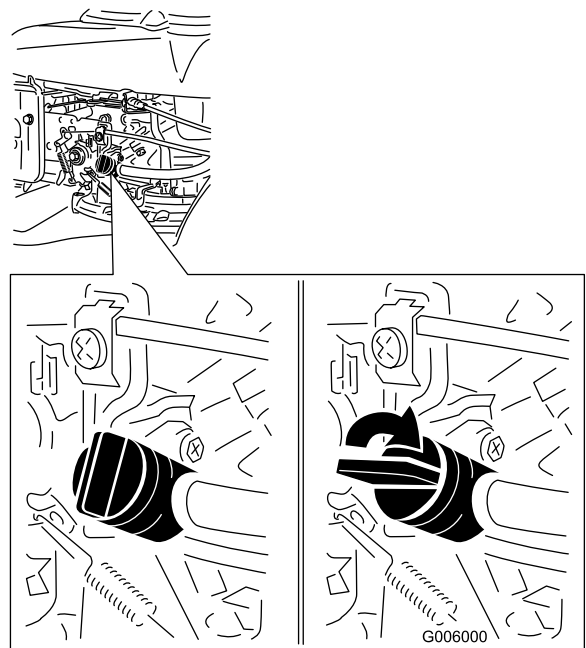

Figure 23

3. Move the choke/throttle lever to the Choke position (Figure 18).
4. Hold the blade control bar against the handle and pull the recoil starter once or twice (Figure 24).

Note: Pull the recoil start handle lightly until you feel resistance, then pull it briskly.

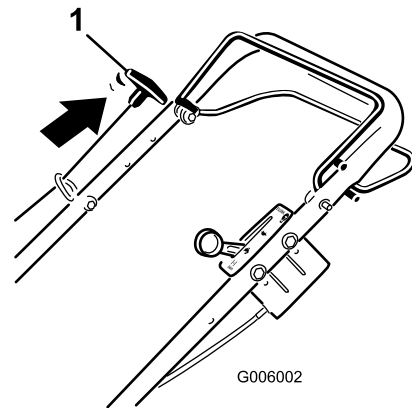

Figure 24

1. Recoil start handle
5. Move the choke/throttle lever to the Fast position (Figure 18).
6. Hold the blade control bar against the handle and pull the recoil starter (Figure 24).
7. If the mower does not start in 1 or 2 pulls, repeat steps 3 through 6.

Note: If the mower still does not start, contact an Authorized Service Dealer.

Stopping the Engine

Service Interval: Before each use or daily

To stop the engine, release the blade control bar (Figure 25).

Important: When you release the blade control bar, both the engine and blade should stop within 3 seconds. If they do not stop properly, stop using your mower immediately and contact an Authorized Service Dealer.

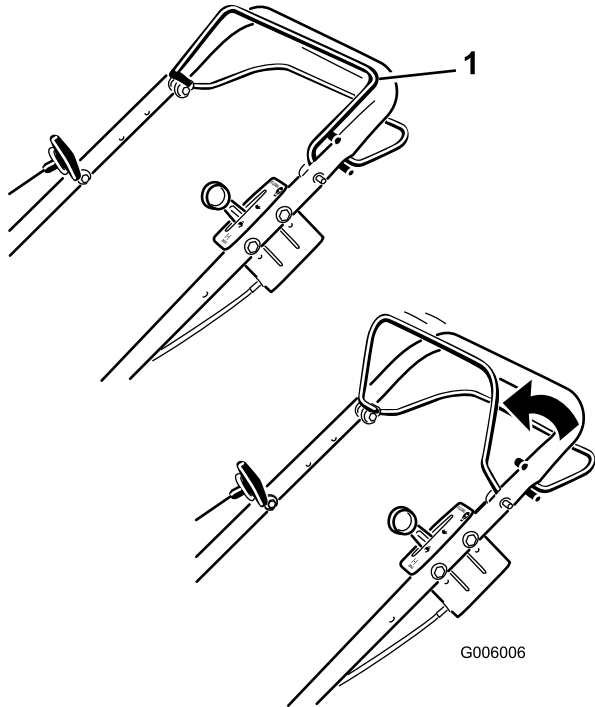

Figure 25

1. Blade control bar

Operating the Self-propel Drive

Model 22271 only

1. To operate the self-propel drive, squeeze the self-propel drive bar against the handle and hold it (Figure 26).

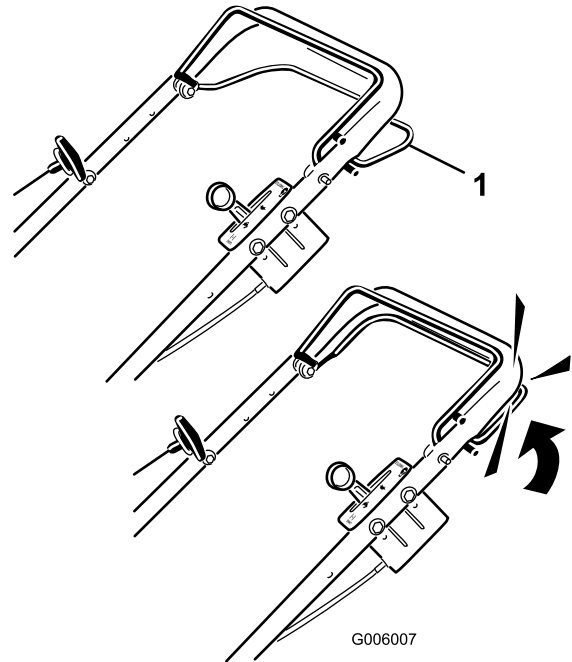

Figure 26

1. Self-propel drive bar

Note: The maximum self-propel drive speed is fixed. To reduce the speed, increase the space between the self-propel drive bar and the handle.

2. To disengage the self-propel drive, release the self-propel drive bar.

Note: The mower comes with freewheeling clutches which make it easier to pull the mower rearward. To disengage the clutches, you may need to push the mower forward one inch (2.5 cm) or more after you release the self-propel drive bar.

Adjusting the Cutting Height

Cutting heights are from 1 inch (25 mm) to 4-1/2 inches (114 mm) in 1/2-inch (13 mm) increments.



Adjusting the cutting height may bring you into contact with the moving blade, causing serious injury.

- Stop the engine and wait for all moving parts to stop.
- Do not put your fingers under the housing when adjusting the cutting height.

Adjust the cutting height as desired (Figure 27). Set all four wheels to the same height.

Note: To raise the mower, move all 4 cutting height levers forward; to lower the mower, move them rearward.

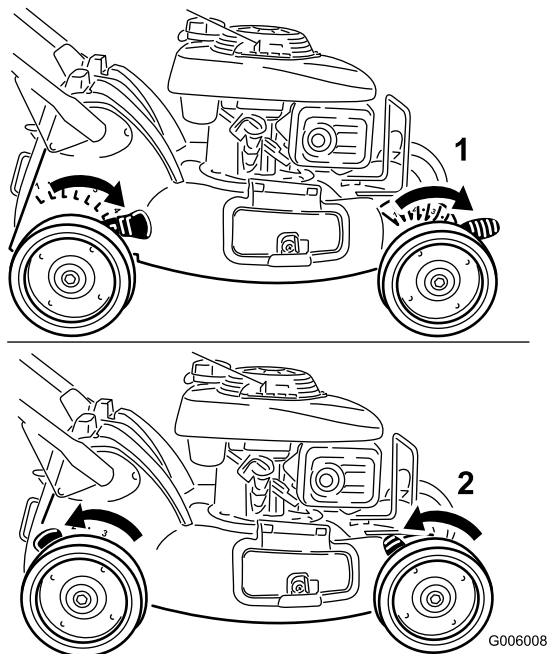

Figure 27

1. Highest height-of-cut position (levers forward)
2. Lowest height-of-cut position (levers rearward)

Mulching the Clippings

Your mower comes from the factory ready to mulch the grass and leaf clippings back into the lawn.

If the grass bag is on the mower, remove it (refer to Removing the Grass Bag) before mulching the clippings. If the side discharge chute is on the mower, remove it and lock the side discharge door (refer to Removing the Side Discharge Chute) before mulching the clippings.

Important: The mower has a safety switch that prevents you from starting the mower unless you first install the mulch plug securely on the mower (Figure 28).

Install the mulch plug as illustrated in Figure 28.

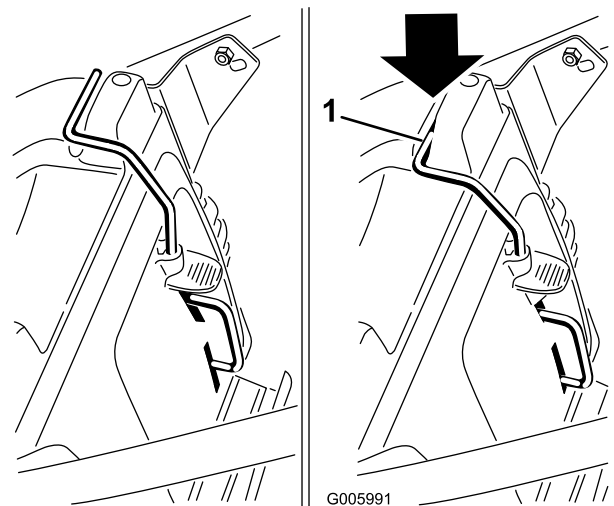

Figure 28

1. Top of mulch plug lever in switch channel

Bagging the Clippings

Use the grass bag when you want to collect grass and leaf clippings from the lawn.

If the side discharge chute is on the mower, remove it and lock the side discharge door (refer to Removing the Side Discharge Chute) before bagging the clippings.



A worn grass bag could allow small stones and other similar debris to be thrown in the operator's or bystander's direction and result in serious personal injury or death to the operator or bystanders.

Check the grass bag frequently. If it is damaged, install a new Toro replacement bag.



The blade is sharp; contacting the blade can result in serious personal injury.

Stop the engine and wait for all moving parts to stop before leaving the operating position.

Installing the Grass Bag

1. Remove the mulch plug (Figure 29).

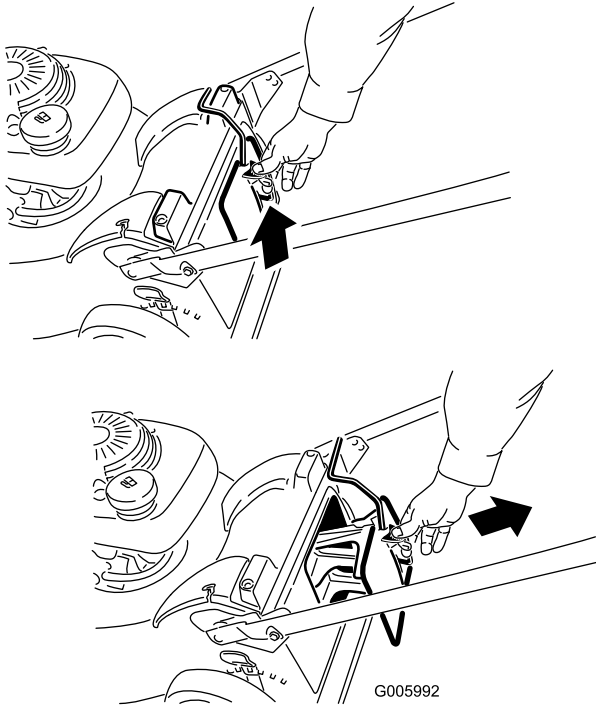

Figure 29

2. Insert the grass bag handle into the grooves at the top of the mower.

Important: The mower has a safety switch that prevents you from starting the mower unless you first install the grass bag securely on the mower.

Removing the Grass Bag

1. Lift the grass bag handle out from the grooves at the top of the mower and remove the bag from the mower (Figure 30).

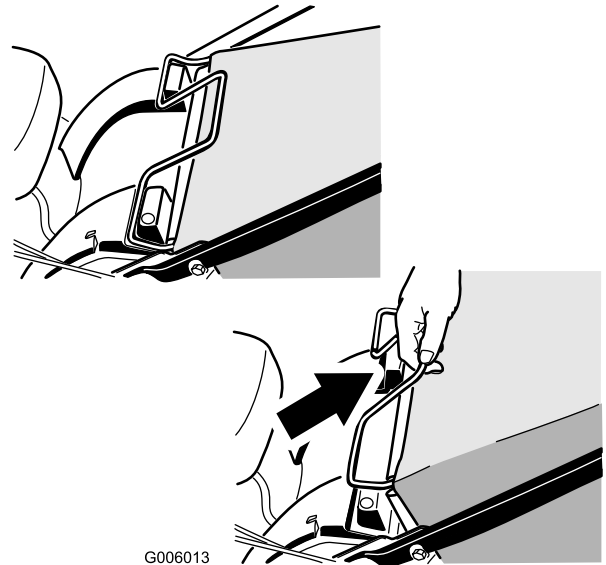

Figure 30

2. Insert the mulch plug (Figure 31).

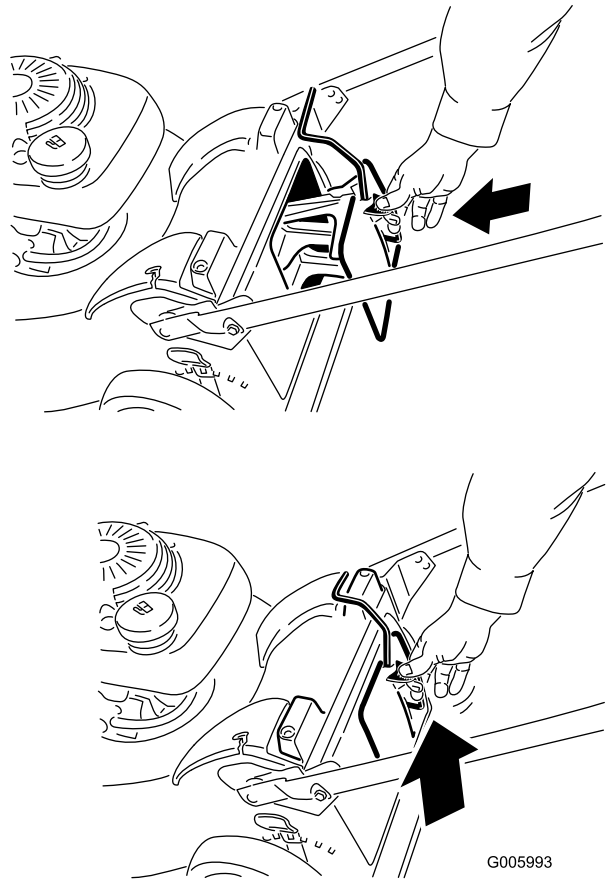

Figure 31

Side-discharging the Clippings

Use the side discharge for cutting very tall grass.

If the bag is on the mower, remove it and insert the mulch plug (refer to Removing the Grass Bag) before side-discharging the clippings.

Important: The mower has a safety switch that prevents you from starting the mower unless you first install the mulch plug securely on the mower (refer to Mulching the Clippings).

Installing the Side Discharge Chute

1. Unlock the side discharge door (Figure 32).

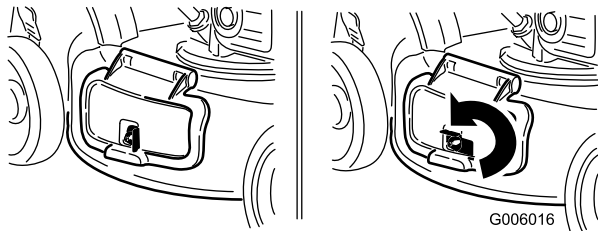

Figure 32

2. Lift open the side discharge door (Figure 33).

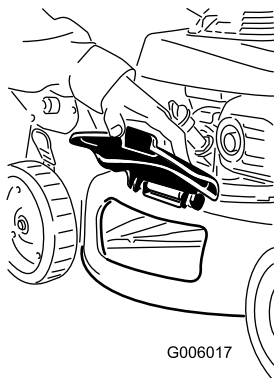

Figure 33

3. Install the side discharge chute and close the door onto the chute (Figure 34).

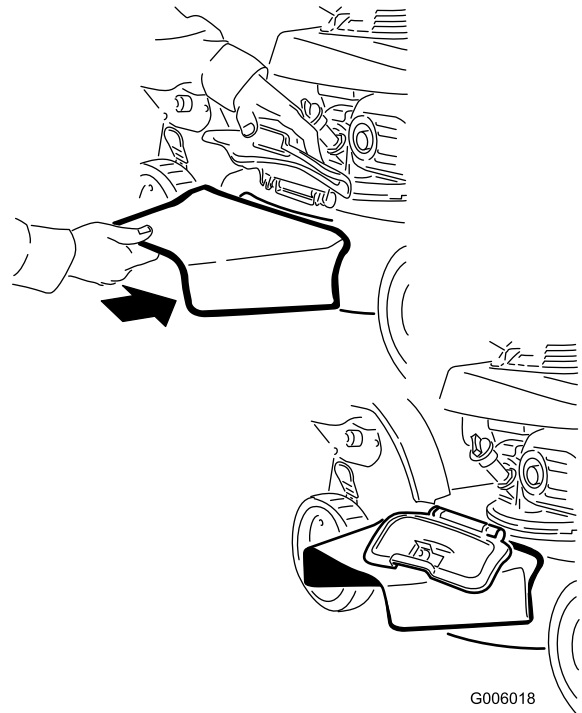

Figure 34

Removing the Side Discharge Chute

To remove the side discharge chute, reverse the steps above.

Important: Lock the side discharge door after you close it (Figure 35).

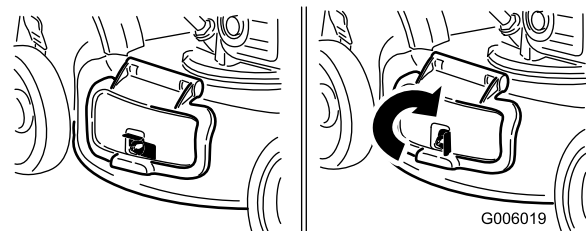

Figure 35

Operating Tips

General Tips

- Maintain a sharp blade throughout the cutting season. Periodically file down nicks on the blade.
- Replace the blade when necessary with an original Toro replacement blade.
- Mow only dry grass or leaves. Wet grass and leaves tend to clump on the yard and can cause the mower to plug or the engine to stall.



Wet grass or leaves can cause serious injury if you slip and contact the blade.

Mow only in dry conditions.

- Clean under the mower housing after each mowing. See Cleaning under the Mower Housing.
- Keep the engine in good running condition.
- Set the engine speed to the fastest position for the best cutting results.



Operating a mower with its engine running at a speed greater than the factory setting can cause the mower to throw a part of the blade or engine into the operator's or bystander's area and result in serious personal injury or death.

- **Do not change the engine speed setting.**
- **If you suspect the engine speed is faster than normal, contact an Authorized Service Dealer.**

- Clean the air filter frequently. Mulching stirs up more clippings and dust which clogs the air filter and reduces engine performance.

Cutting Grass

- Grass grows at different rates at different times of the year. In the summer heat, it is best to cut grass at the 2-inch (51 mm), 2-1/2 inch (64 mm), or 3-inch (76 mm) cutting height settings. Cut only about a third of the grass blade at a time. Do not cut below the 2-1/2 inch (64 mm) setting unless the grass is sparse or it is late fall when grass growth begins to slow down.
- When cutting grass over 6 inches (15 cm) tall, first mow at the highest cutting height setting and walk

slower; then mow again at a lower setting for the best lawn appearance. If the grass is too long and the leaves clump on top of the lawn, the mower may plug and cause the engine to stall.

- Alternate the mowing direction. This helps disperse the clippings over the lawn for even fertilization.

If the finished lawn appearance is unsatisfactory, try one or more of the following:

- Sharpen the blade.
- Walk at a slower pace while mowing.
- Raise the cutting height on your mower.
- Cut the grass more frequently.
- Overlap cutting swaths instead of cutting a full swath with each pass.
- Set the cutting height on the front wheels one notch lower than the rear wheels.

Cutting Leaves

- After cutting the lawn, ensure that half of the lawn shows through the cut leaf cover. You may need to make more than one pass over the leaves.
- For light leaf coverage, set all the wheels at the same cutting height setting.
- If there are more than 5 inches (12.7 cm) of leaves on the lawn, set the front cutting height 1 or 2 notches higher than the rear cutting height. This makes it easier to feed the leaves under the mower housing.
- Slow down your mowing speed if the mower does not cut the leaves finely enough.
- If you mow over oak leaves, you can add lime to the grass in the spring to reduce the acidity of the oak leaves.

Maintenance

Recommended Maintenance Schedule(s)

Maintenance Service Interval	Maintenance Procedure
After the first 5 hours	<ul style="list-style-type: none">• Change the engine oil.
Before each use or daily	<ul style="list-style-type: none">• Check the engine oil level.• Ensure that the engine stops within 3 seconds after releasing the blade control bar.• Check the air cleaner for dirt and/or damage and clean or replace it if necessary.• Clean grass clippings and dirt from under the mower.
Every 100 hours	<ul style="list-style-type: none">• Check the spark plug.
Every 200 hours	<ul style="list-style-type: none">• Replace the spark plug.
Before storage	<ul style="list-style-type: none">• Empty the fuel tank before repairs as directed and before annual storage.
Yearly	<ul style="list-style-type: none">• Clean the air filter (more frequently in dusty operating conditions).• Change the engine oil.• Replace the blade or have it sharpened (more frequently if the edge dulls quickly).

Premaintenance Procedures

Preparing for Maintenance

1. Stop the engine and wait for all moving parts to stop.
2. Disconnect the spark plug wire from the spark plug (Figure 36) before performing any maintenance procedure.

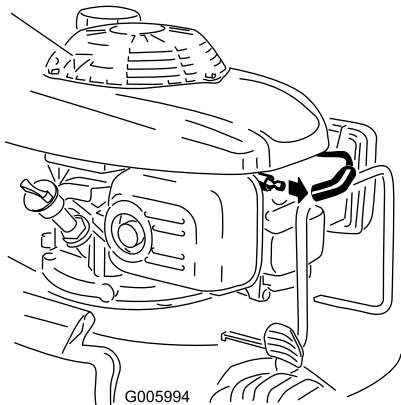

Figure 36

hand fuel pump to remove the fuel. Always tip the mower onto its side with the air filter up.



Tipping the mower may cause the fuel to leak. Gasoline is flammable, explosive and can cause personal injury.

Run the engine dry or remove the gasoline with a hand pump; never siphon.

3. After performing the maintenance procedure(s), connect the spark plug wire to the spark plug.

Important: Before tipping the mower to change the oil or replace the blade, allow the fuel tank to run dry through normal usage. If you must tip the mower prior to running out of fuel, use a

Engine Maintenance

Servicing the Air Cleaner

Service Interval: Before each use or daily
Yearly

1. Press down on the latch tabs on top of the air cleaner cover (Figure 37).

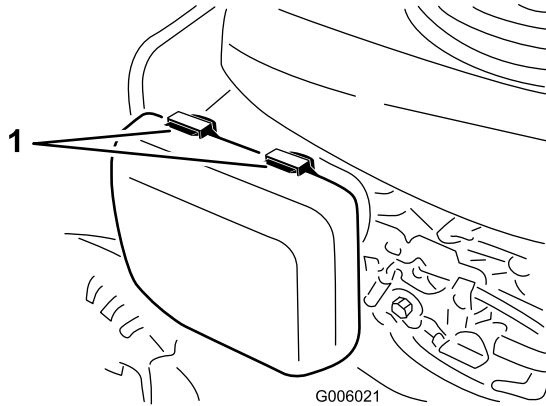

Figure 37

1. Latch tabs

2. Open the cover (Figure 38).

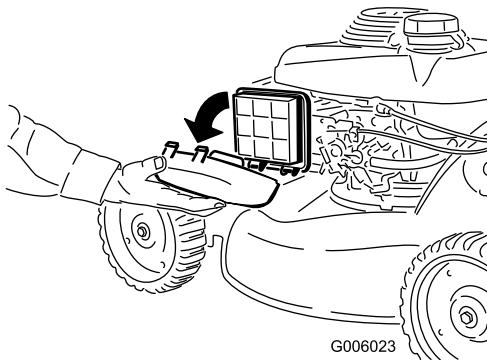

Figure 38

3. Remove the air filter (Figure 39).

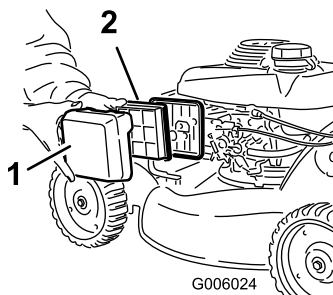

Figure 39

1. Air cleaner cover
2. Air filter

4. If the air filter is damaged or is wet with oil or fuel, replace it.

5. If the air filter is dirty, tap it on a hard surface several times or blow compressed air less than 30 psi (207 kPa) through the side of the filter that faces the engine.

Note: Do not brush the dirt off the filter; brushing forces dirt into the fibers.

6. Remove dirt from the air cleaner body and cover using a moist rag. **Do not wipe dirt into the air duct.**
7. Install the filter into the air cleaner.
8. Close the cover.

Changing the Engine Oil

Service Interval: After the first 5 hours
Yearly

Run the engine a few minutes before changing the oil to warm it. Warm oil flows better and carries more contaminants.

1. Perform the pre-maintenance procedures; refer to Preparing for Maintenance.
2. Remove the dipstick (Figure 40).

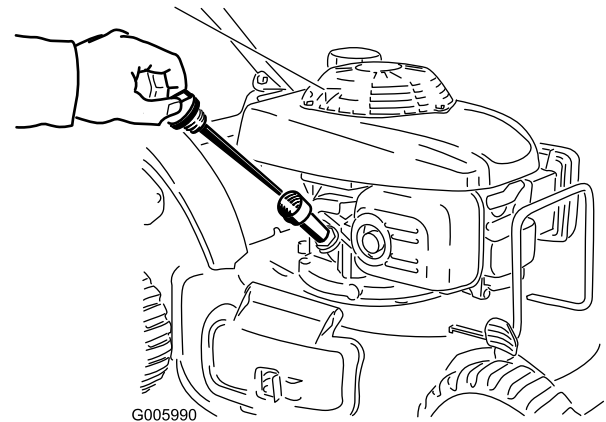

Figure 40

3. Tip the mower onto its side, with the air filter up, to drain the used oil out through the oil fill tube (Figure 41).

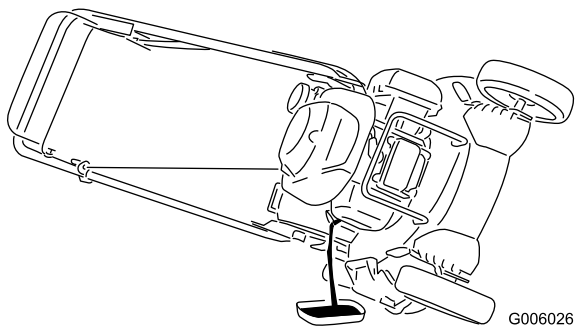

Figure 41

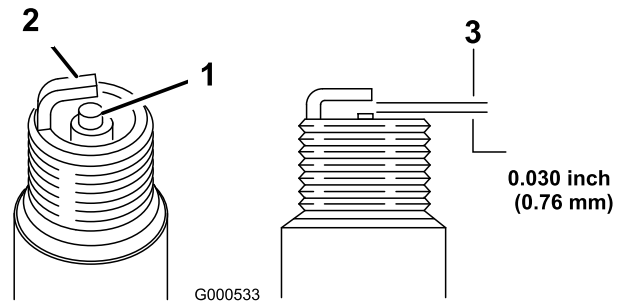

Figure 42

1. Center electrode insulator
2. Side electrode
3. Air gap (not to scale)

4. **Slowly** pour oil into the oil fill tube, periodically checking the level with the dipstick, until the dipstick indicates that the engine is full as illustrated in Figure 40. **Do not overfill.** (Max. fill: 20 oz. (0.55 l), type: SAE 30W detergent oil with an API service classification of SH, SJ, SL, or higher.)

Note: If you overfill the engine, pour some oil out of it.

5. Install the dipstick securely.
6. Dispose of the used oil properly at a local recycling center.

Servicing the Spark Plug

Service Interval: Every 100 hours
Every 200 hours

Use an **NGK BPR6ES** spark plug or equivalent.

1. Stop the engine and wait for all moving parts to stop.
2. Disconnect the wire from the spark plug (Figure 36).
3. Clean around the spark plug.
4. Remove the spark plug from the cylinder head.

Important: Replace a cracked, fouled, or dirty spark plug. Do not clean the electrodes because grit entering the cylinder can damage the engine.

5. Set the gap on the plug to 0.030 in. (0.76 mm) (Figure 42).

6. Install the spark plug and the gasket seal by hand.
7. Tighten the plug 1/2 turn after the spark plug seats to compress the washer.

Note: When installing the original spark plug again, tighten 1/8 to 1/4 turn after the spark plug seats to compress the washer.

Note: Under-tightening the spark plug can cause the plug to become very hot and can damage the engine. Overtightening the spark plug can damage the threads in the engine cylinder head.

8. Connect the wire to the spark plug.

Drive System Maintenance

Adjusting the Self-propel Drive

If the mower does not self-propel or it creeps forward when the self-propel drive bar is more than 2-1/4 inches (57 mm) when you move the self-propel drive bar toward the handle (Figure 43), adjust the self-propel drive.

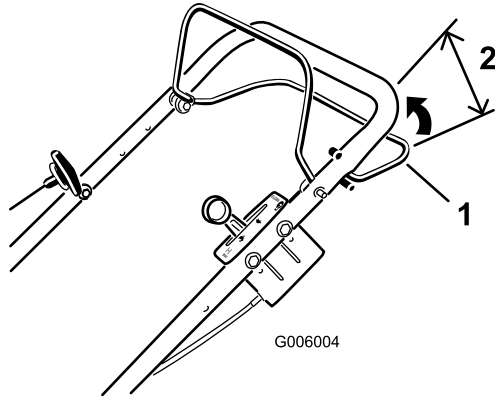

Figure 43

1. Self-propel drive bar
2. 2-1/4 inches (57 mm)

1. Loosen the jam nut (Figure 44).

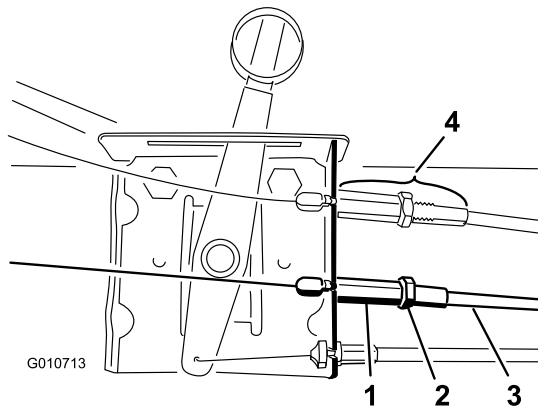

Figure 44

1. Weld nut
2. Jam nut
3. Cable jacket
4. Blade control adjustment hardware—Do not adjust!

2. Thread the cable jacket into the weld nut to increase the gap between the bar and the handle (or unthread the cable jacket out of the weld nut to decrease the gap) (Figure 44) until you achieve the proper gap (Figure 43).
3. Tighten the jam nut.

Blade Maintenance

Maintaining the Cutting Blade

Service Interval: Yearly

Examine the blade whenever you run out of gasoline. If the blade is damaged or cracked, replace it immediately. If the blade edge is dull or nicked, have it sharpened or replace it.



The blade is sharp; contacting the blade can result in serious personal injury.

Wear gloves when servicing the blade.

1. Disconnect the spark plug wire from the spark plug. Refer to Preparing for Maintenance.
2. Tip the mower onto its side, with the air filter up.
3. Use a block of wood to hold the blade steady (Figure 45).

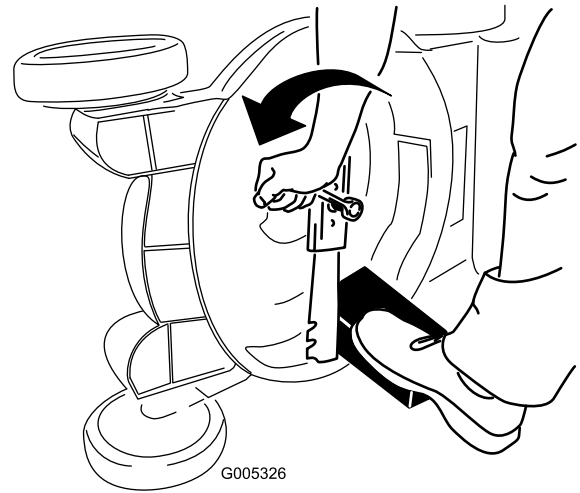

Figure 45

4. Remove the blade, saving all mounting hardware (Figure 45).
5. Install the new blade and all mounting hardware (Figure 46).

Cleaning

Cleaning the Mower Housing

Service Interval: Before each use or daily

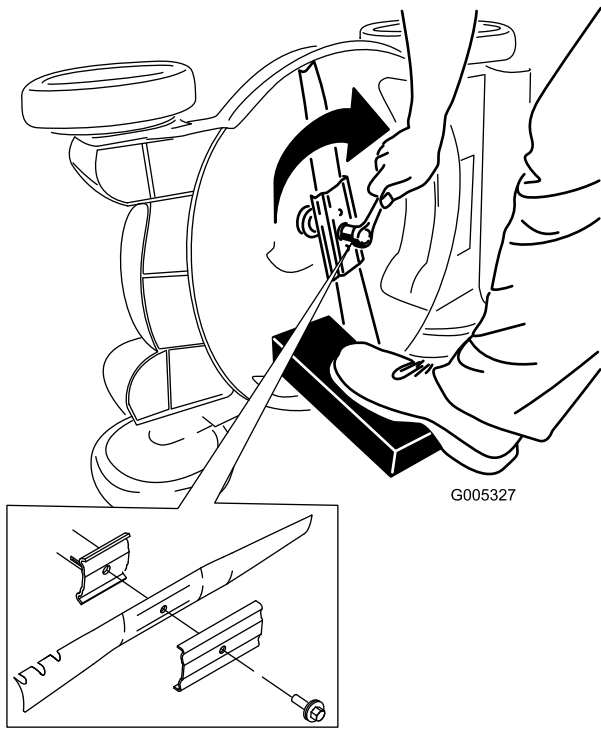

Figure 46

Important: Position the curved ends of the blade to point toward the mower housing.

6. Use a torque wrench to tighten the blade bolt to 40 to 50 ft-lb (54 to 68 N·m).



The mower may dislodge material from under the mower housing.

- Wear eye protection.
- Stay in the operating position (behind the handle).
- Do not allow bystanders in the area.

1. With the engine running on a flat paved surface, spray a stream of water in front of the **right** rear wheel (Figure 47).

The water will splash into the path of the blade, cleaning out the clippings.

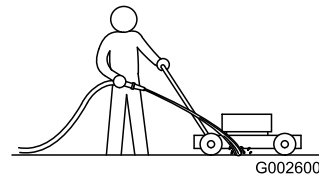

Figure 47

2. When no more clippings come out, stop the water and move the mower to a dry area.
3. Run the engine for a few minutes to dry the housing to prevent it from rusting.

Storage

To prepare the mower for off-season storage, perform the recommended maintenance procedures. Refer to Maintenance.

Store the mower in a cool, clean, dry place. Cover the mower to keep it clean and protected.

Preparing the Fuel System



Gasoline can vaporize if you store it over long periods of time and explode if it comes into contact with an open flame.

- **Do not store gasoline over long periods of time.**
- **Do not store the mower with gasoline in the fuel tank or the carburetor in an enclosure with an open flame. (For example, a furnace or a water heater pilot light.)**
- **Allow the engine to cool before storing it in any enclosure.**

Empty the fuel tank when mowing the last time before storing the mower.

1. Run the mower until the engine stops from running out of fuel.
2. Prime the engine and start it again.
3. Allow the engine to run until it stops. When you can no longer start the engine, it is sufficiently dry.

Preparing the Engine

1. While the engine is still warm, change the oil from the crankcase. Refer to Changing the Engine Oil.
2. Remove the spark plug.
3. Using an oil can, add about one tablespoon of oil to the crankcase through the spark plug hole.
4. Slowly rotate the engine several times, using the starter rope, to distribute the oil.
5. Install the spark plug but do not connect the wire to the spark plug.

General Information

1. Clean the mower housing. Refer to Cleaning under the Mower Housing.
2. Clean any dirt and chaff from the cylinder, cylinder head fins, and blower housing.
3. Remove grass clippings, dirt, and grime from the external parts of the engine, the shrouding, and the top of the mower housing.
4. Check the condition of the blade. Refer to Maintaining the Cutting Blade.
5. Clean the blade brake clutch shield; refer to Cleaning the Blade Brake Clutch Shield.
6. Service the air filter; refer to Servicing the Air Filter.
7. Lubricate the pivot arms; refer to Lubricating the Pivot Arms.
8. Tighten all nuts, bolts, and screws.
9. Touch up all rusted or chipped paint surfaces with paint available from an Authorized Service Dealer.

Removing the Lawn Mower from Storage

1. Check and tighten all fasteners.
2. Remove the spark plug and spin the engine rapidly using the starter to blow excess oil from the cylinder.
3. Clean the spark plug or replace it if it is cracked, broken, or if the electrodes are worn.
4. Install the spark plug and tighten 1/8 to 1/4 turn after the spark plug seats to compress the washer.
5. Perform any needed maintenance procedures; refer to Maintenance.
6. Fill the fuel in the fuel tank with fresh gasoline.
7. Check the engine oil level.
8. Connect the wire to the spark plug.

Troubleshooting

Problem	Possible Cause	Corrective Action
Engine does not start	<ol style="list-style-type: none"> 1. The fuel tank is empty or the fuel system contains stale fuel. 2. The throttle lever is not in the Choke position. 3. The wire is not connected to the spark plug. 4. The spark plug is pitted, fouled, or the gap is incorrect. 	<ol style="list-style-type: none"> 1. Drain and/or fill the fuel tank with fresh gasoline. If the problem persists, contact an Authorized Service Dealer. 2. Move the throttle lever to the Choke position. 3. Connect the wire to the spark plug. 4. Check the spark plug and adjust the gap if necessary. Replace the spark plug if it is pitted, fouled, or cracked.
Engine starts hard or loses power	<ol style="list-style-type: none"> 1. The fuel tank contains stale fuel. 2. The fuel cap vent hole is plugged. 3. The air filter element is dirty and is restricting the air flow. 4. The underside of the mower housing contains clippings and debris. 5. The spark plug is pitted, fouled, or the gap is incorrect. 6. The engine oil level is low or the oil is dirty. 	<ol style="list-style-type: none"> 1. Drain and fill the fuel tank with fresh gasoline. 2. Clean the fuel cap vent hole or replace the fuel cap. 3. Clean the air filter pre-cleaner and/or replace the paper air filter. 4. Clean under the mower housing. 5. Check the spark plug and adjust the gap if necessary. Replace the spark plug if it is pitted, fouled, or cracked. 6. Check the engine oil. Change the oil if it is dirty or add oil if it is low
Engine runs rough	<ol style="list-style-type: none"> 1. The wire is not connected to the spark plug. 2. The spark plug is pitted, fouled, or the gap is incorrect. 3. The throttle lever is not in the Fast position. 4. The air filter element is dirty and is restricting the air flow. 	<ol style="list-style-type: none"> 1. Connect the wire to the spark plug. 2. Check the spark plug and adjust the gap if necessary. Replace the spark plug if it is pitted, fouled, or cracked. 3. Move the throttle lever to the Fast position. 4. Clean the air filter pre-cleaner and/or replace the paper air filter.
Lawn mower or engine vibrates excessively	<ol style="list-style-type: none"> 1. The blade is bent or is out of balance. 2. The blade mounting nuts are loose. 3. The underside of the mower housing contains clippings and debris. 4. The engine mounting bolts are loose. 	<ol style="list-style-type: none"> 1. Balance the blade. If the blade is bent, replace it. 2. Tighten the blade mounting nuts. 3. Clean under the mower housing. 4. Tighten the engine mounting bolts.
Uneven cutting pattern	<ol style="list-style-type: none"> 1. All 4 wheels are not at the same height. 2. The blade is dull. 3. You are mowing in the same pattern repeatedly. 4. The underside of the mower housing contains clippings and debris. 	<ol style="list-style-type: none"> 1. Place all 4 wheels at the same height. 2. Sharpen and balance the blade. 3. Change the mowing pattern. 4. Clean under the mower housing.
Discharge chute plugs	<ol style="list-style-type: none"> 1. The throttle lever is not in the Fast position. 2. The cutting height is too low. 3. You are mowing too fast. 4. The grass is wet. 5. The underside of the lawn mower deck contains clippings and debris. 	<ol style="list-style-type: none"> 1. Move the throttle lever to the Fast position. 2. Raise the cutting height. 3. Slow down. 4. Allow the grass to dry before mowing. 5. Clean the underside of the lawn mower deck.

Problem	Possible Cause	Corrective Action
Mower does not self-propel	<ol style="list-style-type: none"><li data-bbox="586 121 1034 176">1. The self-propel drive cable is out of adjustment or is damaged.<li data-bbox="586 186 1034 220">2. There is debris under the belt cover.	<ol style="list-style-type: none"><li data-bbox="1063 121 1513 176">1. Adjust the self-propel drive cable. Replace the cable if necessary.<li data-bbox="1063 186 1513 241">2. Clean the debris from under the belt cover.

Notes:

Notes:



The Toro Total Coverage Guarantee

A Two-Year Full Warranty (Limited Warranty for Commercial Use)

LCE
21" Commercial
Walk Power Mowers

Conditions and Products Covered

The Toro® Company and its affiliate, Toro Warranty Company, pursuant to an agreement between them, jointly promise to repair any Toro Product, used for normal residential purposes* if defective in materials or workmanship. The following time periods apply from the date of purchase:

Products	Warranty Period
21" Commercial Walk Power Mowers and Accessories	2 year full warranty

This warranty includes the cost of parts and labor, but you must pay transportation costs.

Limited Warranty for Commercial Use

Toro Products used at more than one location, or used for institutional or rental use, are warranted from the date of purchase against defects in materials or workmanship for the following time periods.

Products	Warranty Period
21" Commercial Walk Power Mowers and Accessories	1 year limited warranty
• Kawasaki Engines	2 year limited warranty
• Honda GXV Engines	2 year limited warranty
• Honda GSV Engines	1 year limited warranty

Items and Conditions Not Covered

There is no other express warranty except for special emission system coverage and engine warranty coverage on some products. This express warranty does not cover the following:

- Cost of regular maintenance service or parts, such as filters, fuel, lubricants, oil changes, spark plugs, air filters, blade sharpening/worn blade on mowers, cable/linkage adjustments, or brake and clutch adjustments
- Components failing due to normal wear are not covered by this warranty
- Any product or part which has been altered or misused and requires replacement or repair due to accidents or lack of proper maintenance
- Repairs necessary due to improper battery care, failure to use fresh fuel (less than one month old), or failure to properly prepare the unit prior to any period of non-use over one month
- Pickup and delivery charges
- Operational misuse, neglect, or accidents
- Repairs or attempted repairs by anyone other than an Authorized Toro Service Dealer

Countries Other than the United States or Canada

Customers who have purchased Toro products exported from the United States or Canada should contact their Toro Distributor (Dealer) to obtain guarantee policies for your country, province, or state. If for any reason you are dissatisfied with your Distributor's service or have difficulty obtaining guarantee information, contact the Toro importer. If all other remedies fail, you may contact us at Toro Warranty Company.

*Residential purposes means use of the product on the same lot as your home. Use at more than one location is considered commercial use, and the commercial use warranty would apply.

Owner Responsibilities

You must maintain your Toro Product by following the maintenance procedures described in the *Operator's Manual*. Such routine maintenance, whether performed by a dealer or by you, is at your expense.

Instructions for Obtaining Warranty Service

If you think that your Toro Product contains a defect in materials or workmanship, follow this procedure:

1. Contact any Authorized Toro Service Dealer to arrange service at their dealership. To locate a dealer convenient to you, refer to the *Yellow Pages* of your telephone directory (look under "Lawn Mowers") or access our web site at www.Toro.com. You may also call the numbers listed in item #3 to use the 24-hour Toro Dealer locator system.
2. Bring the product and your proof of purchase (sales receipt) to the Service Dealer. The dealer will diagnose the problem and determine if it is covered under warranty.
3. If for any reason you are dissatisfied with the Service Dealer's analysis or with the assistance provided, contact us at:

LCB Customer Care Department
Toro Warranty Company
8111 Lyndale Avenue South
Bloomington, MN 55420-1196
Toll free at 888-865-5676 (U.S. customers)
Toll free at 888-865-5691 (Canadian customers)

General Conditions

All repairs covered by these warranties must be performed by an Authorized Toro Service Dealer using Toro approved replacement parts. Repair by an Authorized Toro Service Dealer is your sole remedy under this warranty.

Neither The Toro® Company nor Toro Warranty Company is liable for indirect, incidental, or consequential damages in connection with the use of the Toro Products covered by these warranties, including any cost or expense of providing substitute equipment or service during reasonable periods of malfunction or non-use pending completion of repairs under these warranties.

Some states do not allow exclusions of incidental or consequential damages, so the above exclusions may not apply to you.

This warranty gives you specific legal rights, and you may also have other rights which vary from state to state.