



# Replacement Gearbox Cover and Seal Kit

## Greensmaster Flex 18 and Flex 21 Mower

Model No. 117-1461

### Installation Instructions

## Installation

### Required Tools

- Impact gun (3/8 inch drive)
  - Cordless drill (3/8 inch drive)
  - Quick connect adaptor for cordless drill
  - Quick connect to 3/8 drive adaptor
  - 6 inch drill quick connect extension (drill holes in seals)
  - 5/32 drill bit - Quick connect or alternative (holes in seals)
  - 25 lb. spring scale (check/set cable tensions)
  - K-Line TOR 6005 Seal Removal Tool (remove old seals- will require a 1/2 inch drill) or 3 each #12 x 2 inch sheet metal screws w 5/16 inch head
  - K-Line TOR 6009 Seal Installation Tool (to install new seals)
  - 3/8 inch drive ratchet
  - 0-200 in./lb. Torque wrench
  - 12 inch (minimum) Adjustable wrench - 2 each
  - 8 inch needle nose pliers
  - Flat Mill file
  - Plastic head hammer (as required)
  - Pry bar (aid in gear case separation)
  - Snap ring pliers (large)
  - SAE hex key set
  - 3/16 blade screwdriver (clip removal)
  - 3 inch 3/8 drive extension
  - 6 inch 3/8 drive extension
  - 18 mm socket (axle nut removal)
  - 18 mm combination wrenches - 2 each (break torque on axle pulley)
  - 13 mm ratchet wrench with swivel (gearbox attachment nuts)
  - 13 mm 3/8 drive socket (cover & hardware removal)
  - 8 mm hex wrench (oil fill plug - new)
  - 5 mm hex on 3/8 drive (gearbox cover screws)
  - 1/2 inch combination wrenches -2 each (cable removal/adjustment)
  - 5/16 inch socket 3/8 inch drive - Quick connect (insert sheet metal screws) or
  - 1/8 inch Hex wrench or screwdriver (flangette bearing set screws)
  - 3/4 inch combination wrench (nuts on TOR 6009) or adjustable wrench
  - 1 inch combination wrench (vent adapter) or adjustable wrench
  - 1-1/4 inch combination wrench (TOR 6009) or adjustable wrench
  - Oil resistant RTV adhesive (as needed)
  - 94 ounces of Dexron III ATF Fluid
  - Oil drain pan
  - Small funnel
1. Position the machine on a suitable work surface and remove the spark plug wire from the spark plug.
  2. Drain and dispose of the ATF fluid in the gearbox. Refer to the Operator's Manual or Service Manual for the procedure. Retain the drain plug and fill plug for use with the new gear case half.
  3. You can remove the right and left axle shaft seals at this point, prior to the removal of the gearbox from the frame or once it is removed- whichever method you find easiest will work. Take care not to damage the bore or the outside edge face of the bore. If either of these surfaces is damaged, remove any burrs and install the seals with a bead of oil resistant RTV or equivalent or replace the case half.

**Note:** It is recommended that the short shaft (right) side differential axle seal and snap ring be removed to allow easy removal of the gear case cover in Step 10. This operation can be performed at this point while the gear case is still installed in the machine or after Step 8. Either method will work. Use K-Line Tool TOR 6005 to remove the seals, or use sheet metal screws to pry the seal out of the bore. Take care not to damage the left side inside diameter seal bore. If this surface becomes damaged, remove any burrs and loose aluminum fragments and install the new seal with a small amount of oil resistant RTV or equivalent only if the inside diameter of this bore is damaged.

4. Mark the position of the brake, reel and traction control cable jam nuts located at the gearbox ends of these cables. The positions can be marked with either a felt tip pen or paint pen marker. This will enable more accurate reinstallation of the cables at the conclusion of the installation. Loosen the one side of the jam nut assembly to remove the cables from the gear case housing locations. Remove the snap clips that retain the gear case ends of these cables to the brake, reel and traction gear box control linkages.
5. Remove the reel drive and traction drive belt covers, relieve the belt tension of these assemblies and then remove the reel and traction drive pulleys. Remove the reel drive plate. Refer to the Operator's manual or the service manual for detail on the removal procedure.
6. Remove the flangette bearing assemblies.
7. Remove the 13 mm fasteners between the gear box and the engine. Use of a ratchet type 13 mm wrench is helpful in removing these fasteners due to the limited wrench access to these fasteners.
8. Remove the differential shaft right and left seals if they were not removed in step 3. Removal of the right seal is not required, but its removal may ease the effort required to split the gear case halves in step 10.
9. Remove the gear case 5 mm hex fasteners and retain them for use with the new gear case half. Remove and discard the gear case cover and gasket.

**Note:** Make sure the thrust washer (Figure 1) stays with the reel drive shaft. The washer can stick to the gear case cover at the reel drive output shaft needle bearing. The thrust washer will be reused.

10. Remove Shaft-Fork by carefully prying it out with a large standard screwdriver or a pry bar. Insert the new Shaft-Fork provided in this kit; carefully align the index splines to the matching index splines in the reel drive clutch fork. This can be accomplished by pointing the top portion of the Fork-Shaft toward the engine side of the gearbox while holding the reel drive clutch fork in place on the clutch hub inside the gearbox. Seat the Fork-Shaft in the assembly by lightly tapping it into the gearbox through the black seal with the plastic hammer

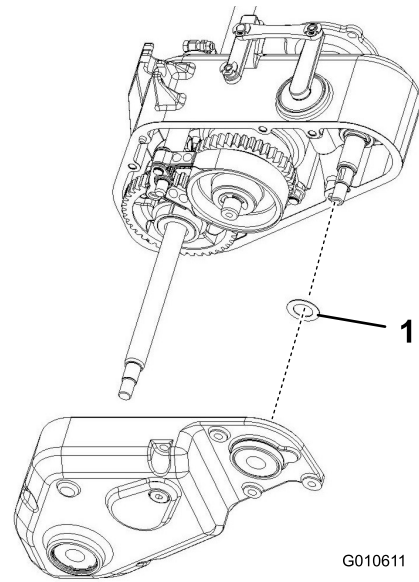
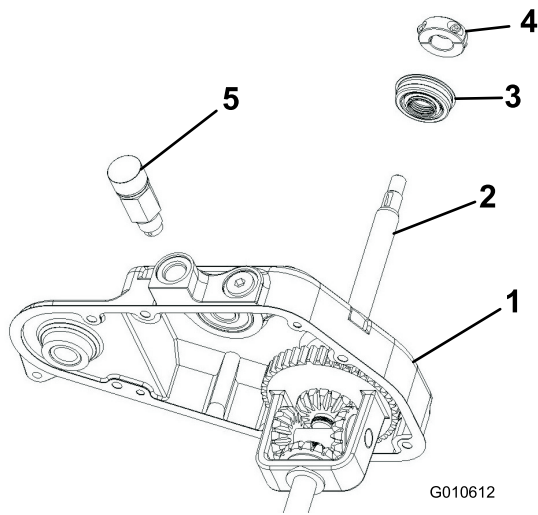

**Figure 1**

1. Thrust washer

11. Install the gasket, provided with the kit, onto the gear case carefully aligning it with the (2) guide pins. Install the new gear case cover, and reinstall the fasteners to 120-140 in-lbs.
12. Install the vent/stand pipe (Figure 2).
13. Install the new seals on the right and left differential shaft locations using the K-Line TOR6009 seal installation tool (Figure 2). This tool must be used to avoid possible damage to the gear case castings. Seal installation can either be performed before or after the gear case is reinstalled onto the engine mount. Stop installation torque to the tool when the metal flange of seal first meets the face of the gear case bore. **Do not attempt to press the seal further or internal damage to the transmission may result.**
14. Apply a thin film of oil (ATF) to the shaft, then place the seal onto the shaft.

**Important:** Ensure that both parts of the seal move together down the length of the shaft by pressing on both the inner and outer diameter of the seals concurrently. Separation of the parts may cause seal damage.



**Figure 2**

- |                    |                    |
|--------------------|--------------------|
| 1. Gear case cover | 4. Collar          |
| 2. Axle shaft      | 5. Vent/stand pipe |
| 3. Seal            |                    |

**Note:** The seal is a unitized design incorporating an inner rubber ID sleeve and an outer metal OD shell. After assembly, the oil side of the sleeve sealing diameter is curled to produce an encapsulated design. The sleeve can move axially within the seal outer cup approximately 0.060 inch (in or out) from the nominal position. The seal should be removed from the shipping container (box, bag, etc.) and inspected. Ensure that the sleeve is located in the nominal position. If the sleeve has moved out away from the normal location, it can be pressed back into position without damage to the seal lip. There can be resistance due to build up of pressure in the internal seal cavity. If so, release the pressure by rotating the inner sleeve while holding the outer shell steady. Be sure to press the sleeve back into its normal position before installation into the gearbox. When in the process of pressing the sleeve back into position ensure that the long excluder lip at the sleeve OD is not inverted. In the event the external lip is inverted at the OD, carefully work the lip back into position before pressing the sleeve into the shell. It is possible to assemble the sleeve into the outer shell with the sleeve excluder lip inverted. In the event this occurs the sleeve should be pressed back out of position, the lip carefully moved into its proper location, the sleeve pressed back into position and internal pressure released. Inspect the shaft surface for nicks, burrs and scratches. Clean and deburr the shaft as necessary before seal installation. Do not use grease, water, spray penetrants, oils, or other lubricants. Never lubricate the seal outer diameter or the gear case bores. The inner and outer seal components should be in their nominal positions.

If the sleeve is dislodged please press it back into position and release any internal pressure before the seal is pressed into the gearbox bore. After the seal is pressed into the gearbox bore, but before the installation tool is removed, there should be a dwell time with load applied to the seal face and shell. Dwell time should be from four to six seconds before removal of the installation tool. The dwell time will ensure the sleeve rubber ID reaches its final seated position preventing possible back out of the sleeve with respect to the outer shell.

15. Install the shaft collars on each axle shaft. (Figure 2). These collars have 2 locking pins that must fit between the raised oval shaped features on the black rubber face of the new oil seals. The purpose of this locking feature is to prevent the center portion of the seal from spinning on the differential axle shaft. Push the collar against the seal and torque the set screws to 95-100 in lbs.
16. Reinstall the gear case onto the engine mount. Be careful to route the throttle cable over the left axle shaft. Torque the fasteners to 17-21 ft-lbs.
17. Reinstall the differential shaft flangette bearing assemblies – verify that the fastener hole for the flangette bearing retainer plates align with the corresponding frame holes. If the holes do not align, follow the alignment process described in Service Bulletin, Greens Reels 09-20. It is suggested that the lower flangette bearing fasteners be torqued first to minimize any twisting effect induced in the assembly that could affect shaft to frame alignment. Torque the flangette bearing assembly fasteners to 17-21 ft-lbs. Then torque the flangette bearing set screws to 50 to 65 in-lbs.
18. Reinstall the traction drive pulleys and belts. Refer to the Operator's Manual or Service Manual for tensioning procedure.
19. Reinstall the reel drive support plate, pulley and drive belt. Refer to the Operator's Manual or Service Manual for the tensioning procedure.
20. Reinstall the brake, reel and traction control cables; use the marks made in step 4 to position the jam nuts. The Traction cable is located in the left (engine side) gear case casting groove, the brake cable is located in the right casting groove. Refer to the Operator's manual for tensioning procedure.
21. Install the magnetic drain plug.
22. Refill the gear case with 94 ounces of clean Dexron III rated ATF lubricant as follows:
  - A. Place the mower on its traction drums on a level surface.

- B. Remove the check plug from the right-hand side of the transmission (Figure 3).
- C. Remove the fill plug, from the top of the transmission, and add enough Dexron III rated ATF lubricant until the level reaches the bottom of the check hole.
- D. Install the plugs.

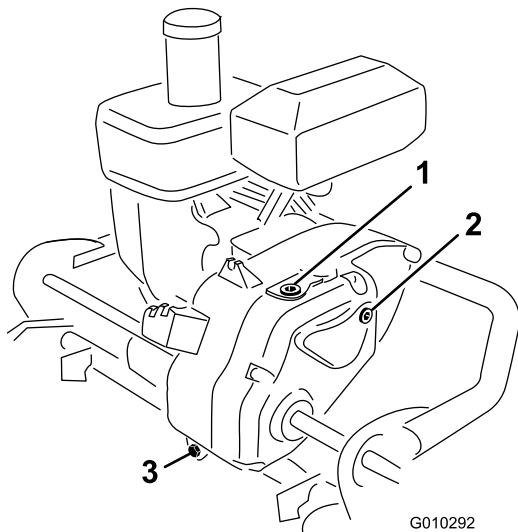

**Figure 3**

- 1. Fill plug
- 2. Check plug
- 3. Drain plug

- 23. Reinstall the spark plug lead to the spark plug, start the engine and verify correct operation of the brake, reel, and traction controls.
- 24. Check for fluid leaks at the gear case seam, the differential axle shaft seals and at the vent assembly.

# Maintenance

## Checking the Transmission Fluid Level

**Service Interval:** Every 50 hours

The transmission is filled at the factory with approximately 94 fluid ounces of Mobil Dexron III automatic transmission fluid.

**Note:** The seals used in the transmission are internally lubricated with grease. During initial operation of mower, slight weeping of grease from these seals will occur. Wipe off excess grease.

**Important:** Use only Mobil Dexron III or equivalent transmission fluids. Other fluids could cause system damage.

**When the transmission is warm, the transmission fluid is hot and under pressure. Allow the transmission to cool before servicing. Use caution when removing the check, fill or drain plugs from the transmission.**

- 1. Place the mower on its drums on a level surface.
- 2. Remove the check plug from the right-hand side of the transmission (Figure 3). The oil level should come to the bottom of the hole. If it does not, remove the fill plug, from the top of the transmission, and add enough of the proper oil type until the level reaches the bottom of the check hole.
- 3. Install the plugs.

## Changing the Transmission Fluid

**Service Interval:** After the first 25 hours

Every 800 hours (Or 2 years,  
whichever occurs first)

**Important:** Use only Mobil Dexron III or equivalent transmission fluids. Other fluids could cause system damage.



**When the transmission is warm, the transmission fluid is hot and under pressure. Allow the transmission to cool before servicing. Use caution when removing the check, fill or drain plugs from the transmission.**

1. Place a drain pan at the rear of the machine.
2. Remove the drain plug from the rear of the transmission (Figure 3).  
**Note:** On machines with serial number prior to 259999999, it is recommended that the drain plug be replaced with a magnetic drain plug, Toro Part No. 110-2455.
3. Push down on the handle and tip the machine back. Remove the fill and check plugs from the transmission (Figure 3).
4. When the fluid is drained, install the drain plug.
5. Place the mower on its drums on a level surface.
6. Fill the transmission with approximately 94 fluid ounces of the proper type of transmission fluid until the level reaches the bottom of the check hole; refer to Checking the Transmission Fluid.
7. Install the check and fill plugs.

**Notes:**

**Notes:**



**Count on it.**