

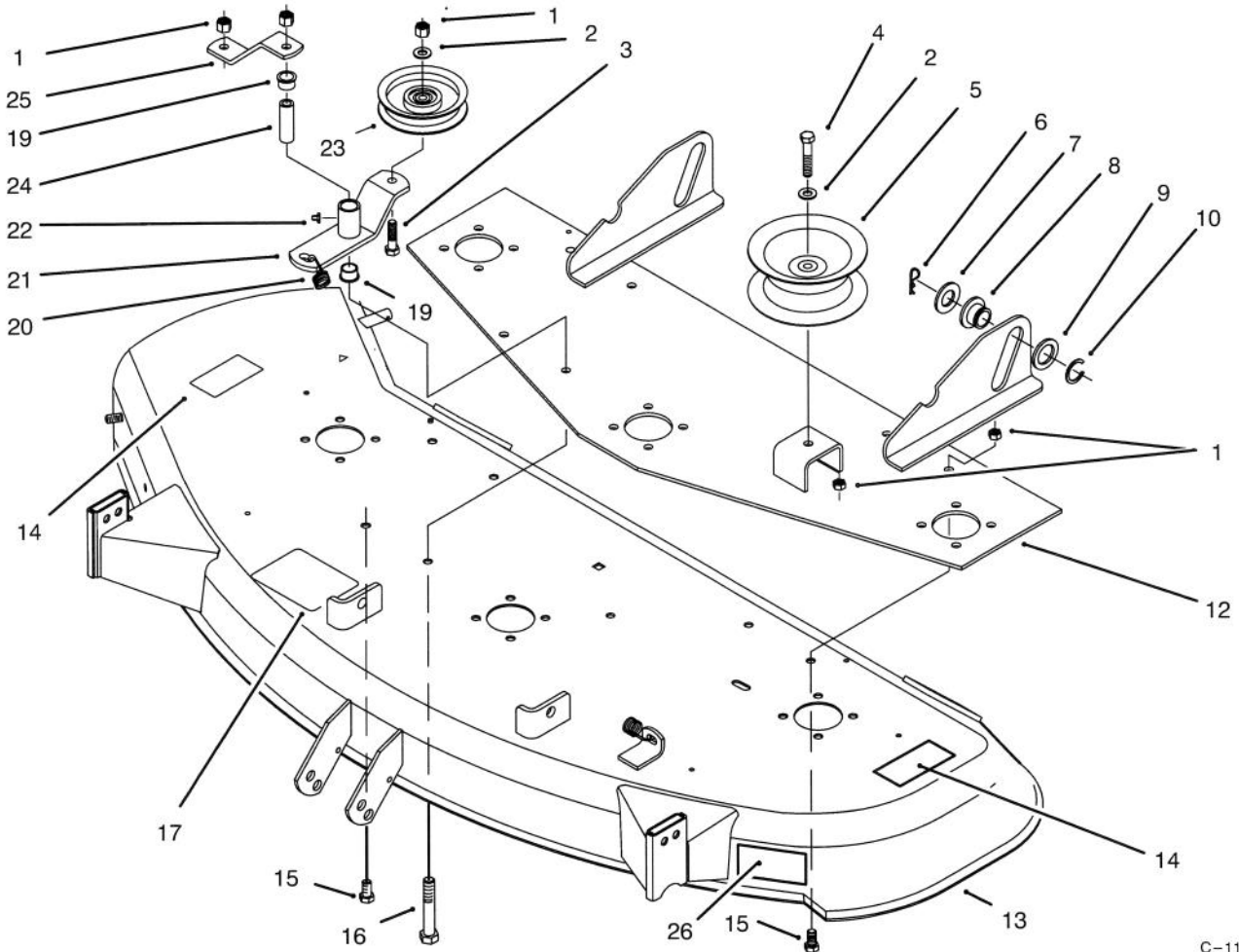

<b>MODEL NO. 78260-490001- 690001 &amp; UP</b>	<b>PARTS CATALOG</b>
<b>48" MOWER</b> for Wheel Horse® Yard/Garden Tractor	



C-1130

### DECK & IDLER ASSEMBLY

Ref. No.	Part No.	Description	Qty.
1	3296-39	Nut - Hex	8
2	3256-24	Washer - Flat	2
3	323-9	Screw - HH	1
4	323-11	Screw - HH	1
5	92-7082	Pulley - Idler	1
6	933507	Hairpin - Cotter	2
7	3256-28	Washer - Flat	2
8	78-7340	Roller - Lift	2
9	920239	Washer	2
10	32151-29	Ring - Retaining	2
12	79-4410-01	Plate - Support	1
13	92-6320-01	Deck & Decal ASM (Incl. Ref.# 14 & 18)	1

Ref. No.	Part No.	Description	Qty.
14	92-7108	Decal - Danger	2
15	323-6	Screw - HH	5
16	323-14	Screw - HH	1
17	116286	Decal - Belt	1
19	109859	Bushing - Flange	2
20	116172	Spring	1
21	78-3150-03	Arm - Idler	1
22	302-26	Fitting - Grease	1
23	92-7084	Pulley - Idler	1
24	79-2760	Spacer	1
25	78-3140-03	Strap - Brace	1
26	68-3380	Decal - Wheel Adjust.	2

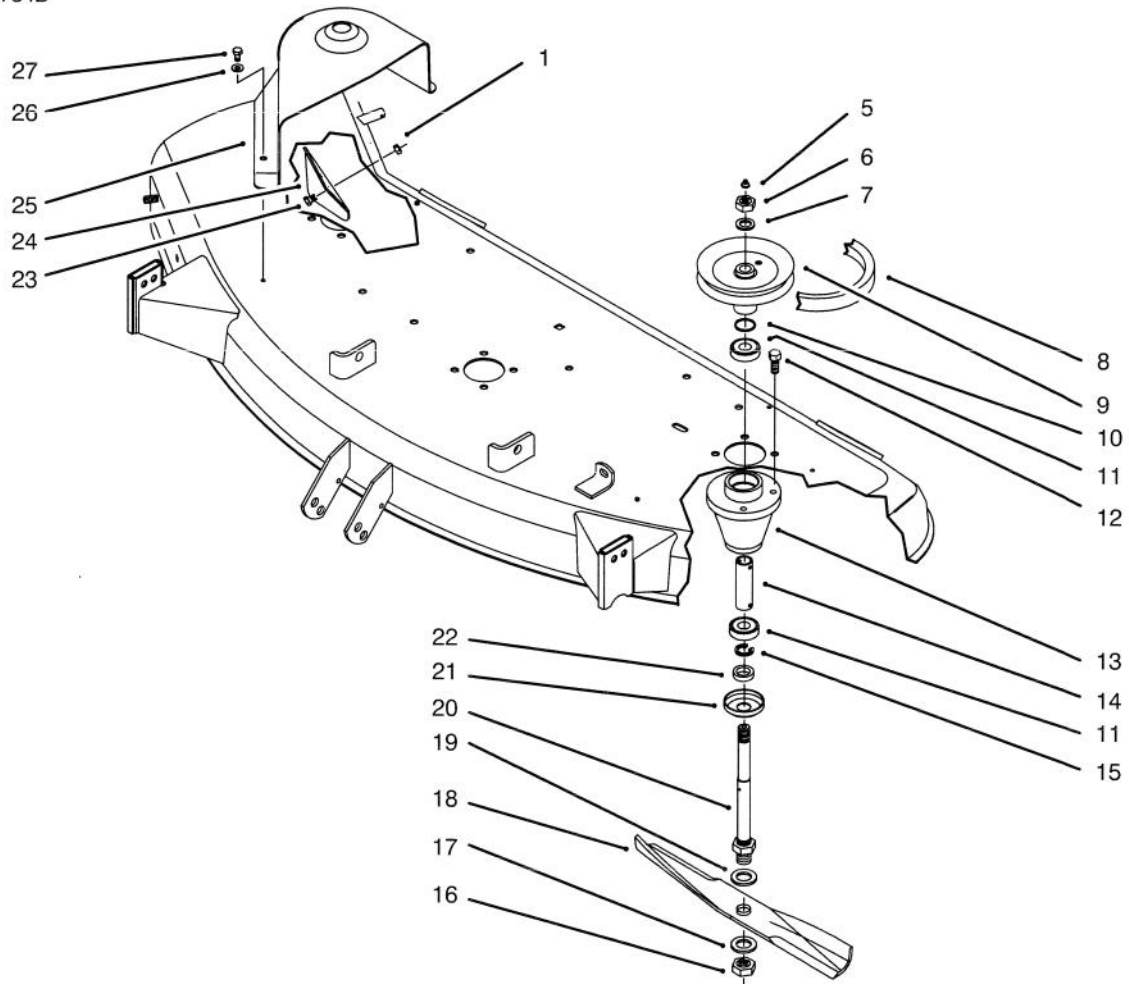

C-1131A

## COVER & SPINDLE ASSEMBLY

Ref. No.	Part No.	Description	Qty.
1	3296-29	Nut - Hex	2
5	302-5	Fitting - Grease	3
6	3220-6	Nut - Jam	3
7	3253-8	Washer - Lock	3
8	79-5280	Beit - V	1
9	92-7083	Pulley - Spindle	3
10	971015	Seal	3
11	109966	Bearing - Ball	6
12	9080326	Screw - HH	12
13	114568	Housing - Spindle	3
14	116085	Tube	3
15	32120-42	Ring - Retaining Internal	3
16	3220-7	Nut - Hex Jam	3

Ref. No.	Part No.	Description	Qty.
17	9202574	Washer - Flat	3
18	106637	Set - Blade, 16"	1
19	3256-28	Washer - Flat	3
20	78-6710	Shaft - Spindle	3
21	106067	Cup - Spindle	3
22	106068	Spacer - Blade	3
23	322-3	Screw - HH	2
24	93-1610-01	Guard - Chute	1
25	86-9220	Cover - Belt R.H.	1
*	86-9210	Cover - Belt L.H.	1
26	3256-22	Washer - Flat	6
27	32144-4	Screw - Hex Washer Hd. Thread Forming	6

\*Not Illustrated

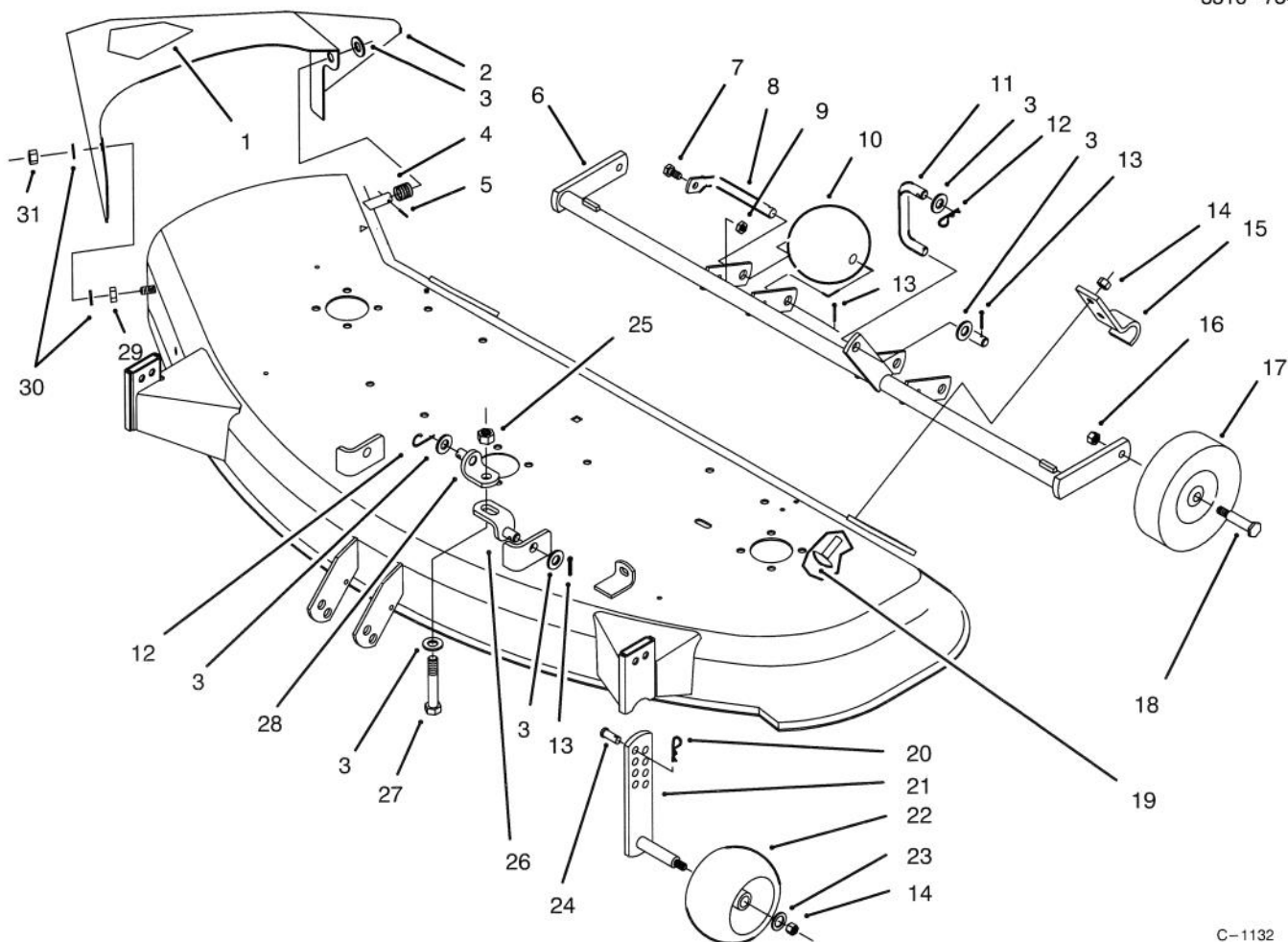

C-1132

## SUSPENSION ASSEMBLY

Ref. No.	Part No.	Description	Qty.	Ref. No.	Part No.	Description	Qty.
1	93-1122	Decal - Danger	1	16	32146-2	Nut - Hex	2
2	88-2750-01	Chute & Decal ASM (Incl. Ref.# 1)	1	17	110506	Wheel - Gage	2
3	3256-26	Washer - Flat	9	18	5188	Bolt - Shoulder	2
4	93-1630	Spring	1	19	3231-25	Screw - HH	4
5	3272-10	Pin - Cotter	1	20	933505	Hairpin - Cotter	2
6	79-4140-03	Support - Gage Wheel	1	21	68-2350	Plate - Gage Wheel	2
7	321-4	Screw - HH	3	22	68-2730	Wheel - Gage	2
8	118960	Shaft - Roller	3	23	3256-24	Washer - Flat	2
9	3296-42	Hex Nut	3	24	283-2	Pin - Yoke	2
10	29-4820	Roller	3	25	3218-5	Nut - Jam	2
11	79-5380	Link - Rear	1	26	86-9240	Bracket - Lower Lift	2
12	933506	Hairpin - Cotter	3	27	325-13	Screw - HH	2
13	3272-21	Pin - Cotter	6	28	86-9250	Bracket - Upper Lift	2
14	3296-39	Nut - Hex	6	29	116080	Bushing - Pivot	1
15	110837	Clamp	2	30	93-1633	Washer - Nylon	2
				31	9152366	Nut - Hex	1

# TORO PART NUMBER INDEX

3316-734B

Part No.	Description	Pg. Ref. No. No. Qty.	Part No.	Description	Pg. Ref. No. No. Qty.
5188	Bolt – Shoulder	3 18 2	92-6320-01	Deck & Decal ASM	1 13 1
106067	Cup – Spindle	2 21 3	92-7082	Pulley – Idler	1 5 1
106068	Spacer – Blade	2 22 3	92-7083	Pulley – Spindle	2 9 3
106637	Set – Blade, 16”	2 18 1	92-7084	Pulley – Idler	1 23 1
109859	Bushing – Flange	1 19 2	92-7108	Decal – Danger	1 14 2
109966	Bearing – Ball	2 11 6	93-1122	Decal – Danger	3 1 1
110506	Wheel – Gage	3 17 2	93-1610-01	Guard – Chute	2 24 1
110837	Clamp	3 15 2	93-1630	Spring	3 4 1
114568	Housing – Spindle	2 13 3	93-1633	Washer – Nylon	3 30 2
116080	Bushing – Pivot	3 29 1	283-2	Pin – Yoke	3 24 2
116085	Tube	2 14 3	302-5	Fitting – Grease	2 5 3
116172	Spring	1 20 1	302-26	Fitting – Grease	1 22 1
116286	Decal – Belt	1 17 1	321-4	Screw – HH	3 7 3
118960	Shaft – Roller	3 8 3	322-3	Screw – HH	2 23 2
920239	Washer	1 9 2	323-6	Screw – HH	1 15 5
920257	Washer – Flat	2 17 3	323-9	Screw – HH	1 3 1
933505	Hairpin – Cotter	3 20 2	323-11	Screw – HH	1 4 1
933506	Hairpin – Cotter	3 12 3	323-14	Screw – HH	1 16 1
933507	Hairpin – Cotter	1 6 2	325-13	Screw – HH	3 27 2
971015	Seal	2 10 3	3218-5	Nut – Jam	3 25 2
9080326	Screw – HH	2 12 12	3220-6	Nut – Jam	2 6 3
9152366	Nut – Jam	3 31 1	3220-7	Nut – Jam	2 16 3
29-4820	Roller	3 10 3	3231-25	Screw – HH	3 19 4
68-2350	Plate – Gage Wheel	3 21 2	3253-8	Washer – Lock	2 7 3
68-2730	Wheel – Gage	3 22 2	3256-22	Washer – Flat	2 26 6
68-3380	Decal – Wheel Adjust.	1 26 2	3256-24	Washer – Flat	1 2 2
78-3140-03	Strap – Brace	1 25 1	3256-24	Washer – Flat	3 23 2
78-3150-03	Arm – Idler	1 21 1	3256-26	Washer – Flat	3 3 9
78-6710	Shaft – Spindle	2 20 3	3256-28	Washer – Flat	1 7 2
78-7340	Roller – Lift	1 8 2	3256-28	Washer – Flat	2 19 3
79-2760	Spacer	1 24 1	3272-10	Pin – Cotter	3 5 1
79-4140-03	Support – Gage Wheel	3 6 1	3272-21	Pin – Cotter	3 13 6
79-4410-01	Plate – Support	1 12 1	3296-29	Nut – Hex	2 1 2
79-5280	Belt – V	2 8 1	3296-39	Nut – Hex	1 1 8
79-5380	Link – Rear	3 11 1	3296-39	Nut – Hex	3 14 6
86-9210	Cover – Belt L.H.	2 * 1	3296-42	Hex Nut	3 9 3
86-9220	Cover – Belt R.H.	2 25 1	32120-42	Ring – Retaining Internal	2 15 3
86-9240	Bracket – Lower Lift	3 26 2	32144-4	Screw – Hex Washer Hd.	2 27 6
86-9250	Bracket – Upper Lift	3 28 2	32146-2	Nut – Hex	3 16 2
88-2750-01	Chute & Decal ASM	3 2 1	32151-29	Ring – Retaining	1 10 2