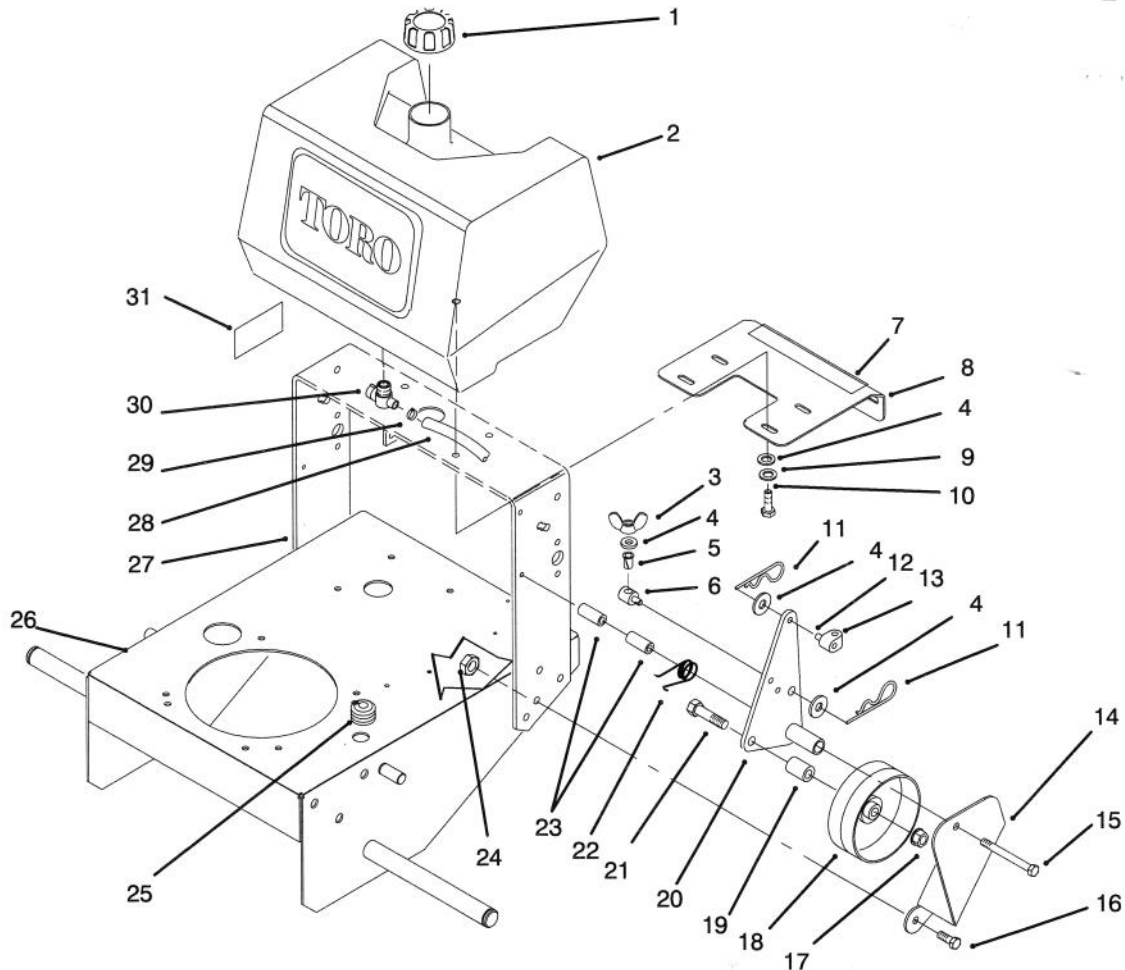

TORO

MODEL NO. 30181-590001 & UP

**PARTS
CATALOG****PROLINE MID-SIZE TRACTION UNIT
18HP GEAR DRIVE**

C-2151

FRAME, FUEL TANK AND WHEEL DRIVE IDLER

Ref. No.	Part No.	Description	No. Used
1	55-3570	Cap - Fuel Tank	1
2	82-8440	Tank - Fuel	1
3	32103-25	Nut - Wing	2
4	3256-23	Washer - Flat	9
5	52-2890	Bushing	2
6	68-9690	Fitting - Rod	2
7	82-7750	Decal - Ground Speed	1
8	66-7400	Plate - Control	1
9	3253-4	Washer - Lock	4
10	322-4	Screw - Hex. Hd. Cap	4
11	3290-307	Pin - Cotter	4
12	283-6	Pin - Clevis	2
13	74-0521	Fitting - Rod	2
14	67-6380	Bracket - Support L.H.	1
*	67-6370	Bracket - Support R.H.	1
15	323-16	Screw - Hex. Hd. Cap	2
16	323-6	Screw - Hex. Hd. Cap	6

Ref. No.	Part No.	Description	No. Used
17	3296-23	Nut - Lock	2
18	51-4480	Idler - Wheel	2
19	51-4490	Spacer - Idler Wheel	2
20	74-0220	Idler - Bracket L.H.	1
*	74-0230	Idler - Bracket R.H.	1
21	51-4450	Screw - Leveler	2
22	51-4380	Spring - Torsion L.H.	1
*	51-4370	Spring - Torsion R.H.	1
23	74-0040	Spacer - Pivot Idler	4
24	3296-39	Nut - Lock	8
25	237-124	Grommet	1
26	93-1156	Frame	1
27	74-0360	Frame - Rear	1
28	47-2982	Hose - Fuel	1
29	2412-98	Clamp - Fuel line	1
30	74-0510	Valve - Fuel	1
31	74-0490	Decal - Fuel Shut Off	1

*Not Illustrated

© The TORO Company -1994
All Rights Reserved

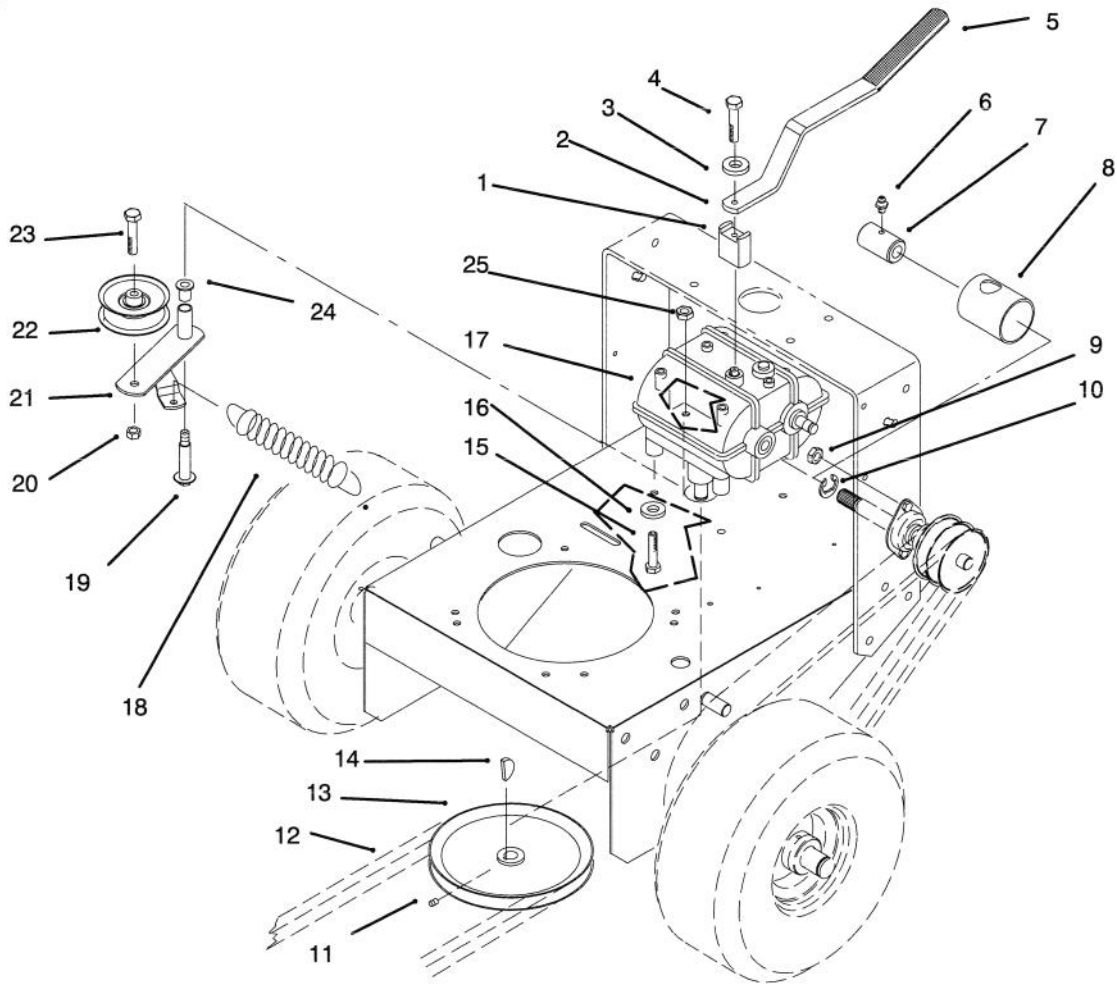

C-2152

TRANSMISSION, IDLER, DRIVE PULLEYS & DRIVE BELTS

Ref. No.	Part No.	Description	No. Used
1	72-2190	Mount - Shift Lever	1
2	74-0320	Lever - Shift	1
3	7-5461	Spacer	1
4	329-10	Screw - Hex. Hd. Cap	1
5	47-1970	Grip - Engagement	1
6	302-5	Fitting - Grease	2
7	51-4260	Coupler	1
8	51-4220	Guard - Coupler	2
9	3296-42	Nut - Lock	4
10	32120-64	Ring - Retaining	3
11	3241-5	Screw - Socket Hd. Cap	1
12	26-9670	Belt - Traction	1

Ref. No.	Part No.	Description	No. Used
13	51-4190	Pulley - Driven	1
15	322-2	Screw - Hex. Hd. Cap	4
16	3253-4	Washer - Lock	12
17	74-0610	Transmission	1
18	68-2190	Spring - Extension	18
19	27-6230	Bolt	1
20	3296-39	Nut - Lock	2
21	16-7509	Lever - Idler (Incl. Ref.#24)	1
22	62-4540	Pulley - Idler	1
23	323-8	Screw - Hex. Hd.	1
24	256-155	Bushing	2
25	3296-6	Nut	1

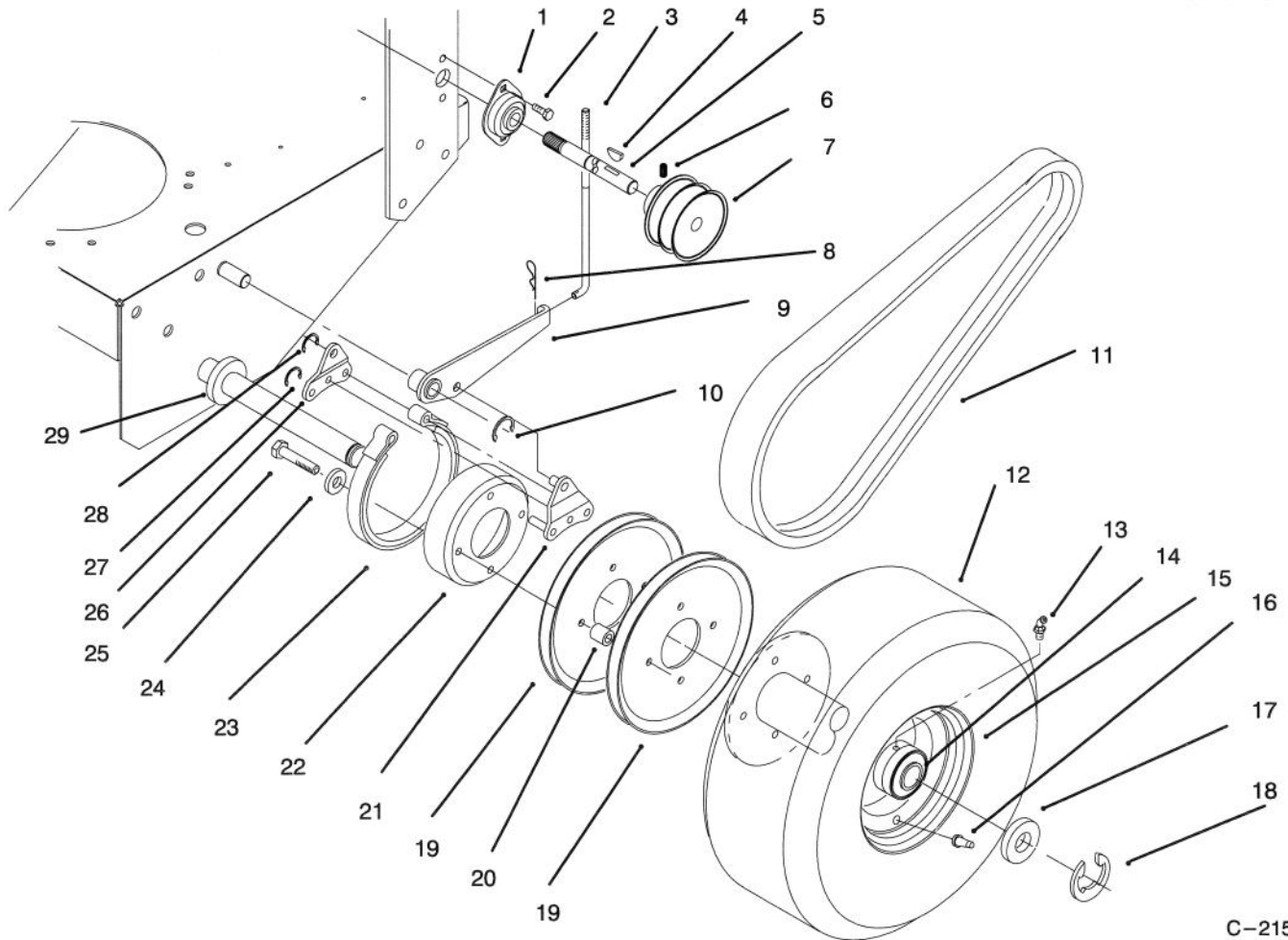

C-2153

AXLE, BRAKE AND WHEEL DRIVE AND BELTS

Ref. No.	Part No.	Description	No. Used	Ref. No.	Part No.	Description	No. Used
1	51-4270	Bearing - Shaft Extension	2	17	10-8110	Washer - Flat	A/R
2	321-4	Screw - Hex. Hd. Cap	4	18	32151-91	Ring - Retaining	2
3	51-4580	Rod - Brake	2	19	51-4160	Pulley - Wheel	4
4	3257-5	Key - Woodruff	3	20	51-4170	Spacer - Pulley	8
5	51-4240	Shaft - Extension R.H.	1	21	51-4650	Link - Brake	2
*	51-4250	Shaft - Extension L.H.	1	22	51-4180	Drum - Brake	2
6	3245-3	Screw - Socket Hd. Set	2	23	51-4700	Brake Band Assembly	2
7	74-0480	Pulley - Drive	2	24	3253-4	Washer - Lock	12
8	3290-307	Pin - Cotter	2	25	322-7	Screw - Hex. Hd. Cap	8
9	51-4610	Brake Arm L.H.	1	26	51-4660	Plate - Link Brake	2
*	51-4600	Brake Arm R.H.	1	27	32151-72	Ring - Retaining	4
10	32151-40	Ring - Retaining	2	28	32151-56	Ring - Retaining	2
11	51-4290	Belt - Drive	2	29	51-4230	Washer - Wheel	2
12	231-117	Tire	2	*	54-2750	V-Belt - Deck Drive (36" & 44" Cutting Units)	1
13	302-11	Fitting - Grease	2	*	55-7660	V-Belt - Deck Drive (52" Cutting Unit)	1
14	92-1746	Bearing	4				
15	242-80	Rim	2				
16	232-27	Valve Stem	2				

*Not Illustrated

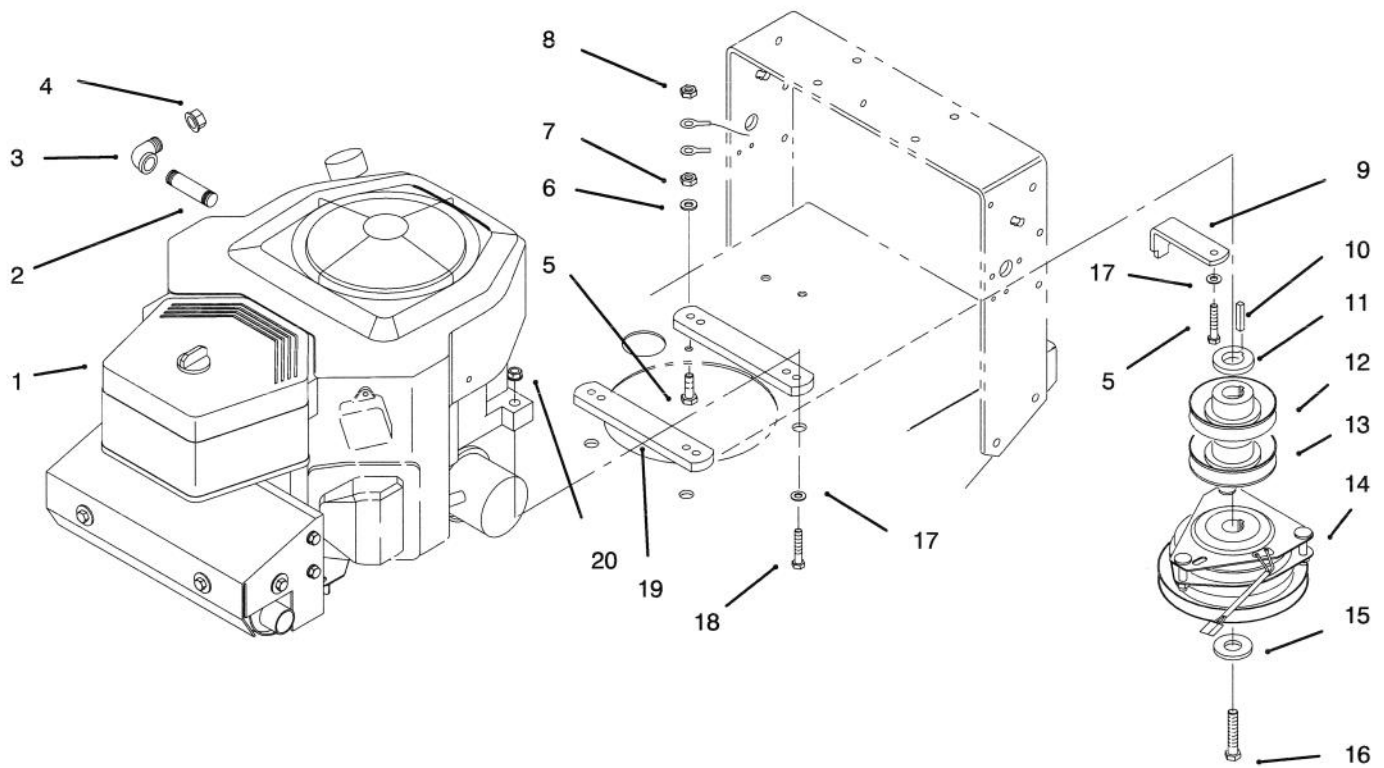

C-2154

ENGINE AND CLUTCH ASSEMBLY

Ref. No.	Part No.	Description	No. Used
1	93-1168	Engine (Kohler CV18S - PS 61521)	1
2	289-42	Pipe Nipple	1
3	2811-10	Elbow - 90° Street	1
4	288-4	Pipe Cap	1
5	322-10	Screw - Hex. Hd. Cap	2
6	3255-8	Washer - External Tooth	1
7	32153-3	Nut - Lock	1
8	32149-1	Nut - Lock	1
9	51-4540	Retainer - Clutch	1
10	5-0930	Key	1

Ref. No.	Part No.	Description	No. Used
11	93-1177	Spacer - Pulley	1
12	74-0060	Sheave - Upper Half	1
13	74-0050	Sheave - Lower Half	1
14	54-3200	Clutch Assembly	1
15	112843	Washer - Clutch	1
16	3212-24	Screw - Hex. Hd. Cap	1
17	3256-23	Washer - Plain	6
18	322-9	Screw - Hex. Hd.	2
19	93-1176	Spacer - Engine	2
20	32152-1	Nut	3

*Not Illustrated

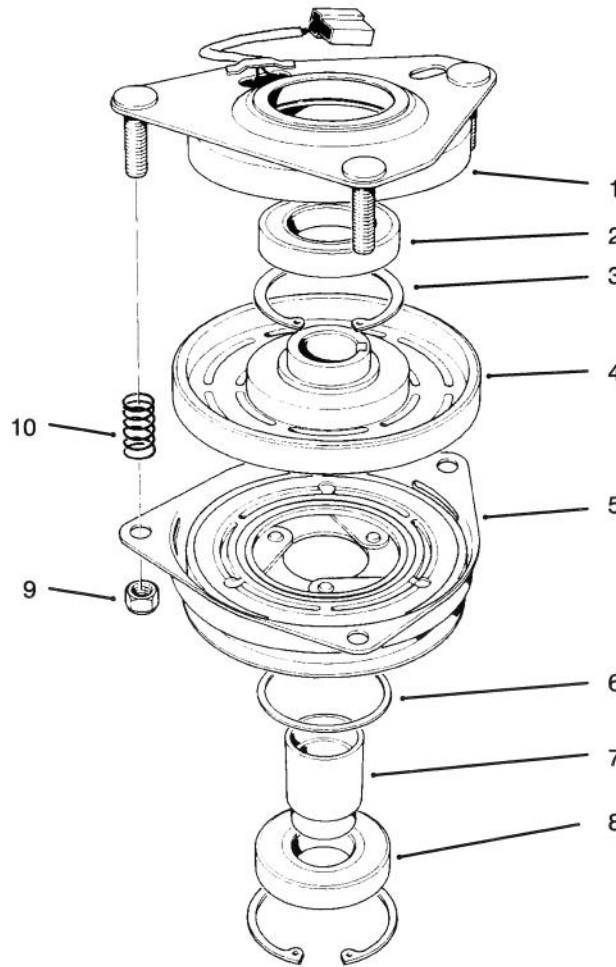

T-0080

CLUTCH ASSEMBLY NO. 54-3200

Ref. No.	Part No.	Description	No. Used	Ref. No.	Part No.	Description	No. Used
1	54-0230	Field Ass'y (Incl. Ref. #2 & 3)	1	6	44-8330	Spacer	1
2	251-292	Bearing - Field	1	7	44-8340	Collar - Bearing	1
3	44-8310	Ring - Retaining	2	8	251-291	Bearing - Pulley	1
4	44-8360	Field Coil, Rotor & Bearing Assembly (Incl. Ref. #1)	1	9	3296-5	Nut - Lock	3
5	55-7410	Armature & Pulley Assemble		10	44-8320	Spring	3
						(Incl. Ref. #3,6,7, & 8)	

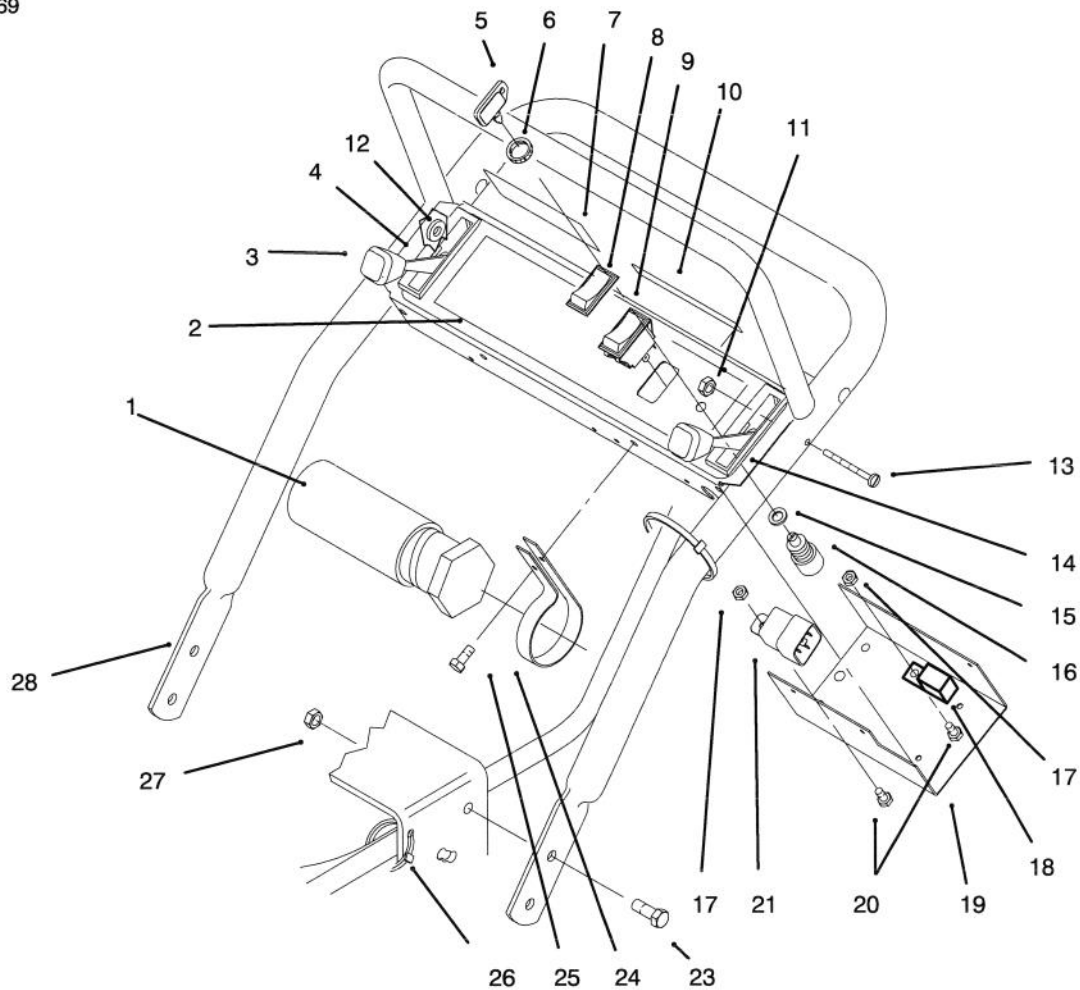

C-2155

HANDLE ASSEMBLY

Ref. No.	Part No.	Description	No. Used
1	74-0720	Tube - Manual	1
2	82-7740	Decal - Proline	1
3	93-1191	Control - Choke	1
4	82-2180	Panel - Control	1
5	63-8360	Key	2
6	218-461	Nut	1
7	71-1280	Decal - Danger	1
8	82-3820	Boot	1
9	82-2300	Switch - Clutch (Incl. Ref.#8)	1
10	65-3090	Decal - Instruction	1
11	3296-2	Nut - Lock	5
12	54-2970	Spacer	2
13	32105-14	Screw - Hex. Hd. Machine	4
14	93-1190	Control - Throttle	1

Ref. No.	Part No.	Description	No. Used
15	3254-5	Washer - Lock	1
16	23-0660	Switch - Ignition (Incl. Ref. #5,6, &15)	1
17	3296-42	Nut - Hex	2
18	86-7910	Module - Interlock	1
19	93-1187	Panel - Bottom	1
20	321-3	Screw - Hex Hd. Cap	2
21	63-7590	Relay	1
23	3234-11	Screw - Hex. Hd. Cap	4
24	2412-120	"R"Clamp	2
25	32144-19	Screw - Self Tapping	4
26	3290-378	Cable Tie	3
27	32128-21	Nut - Lock	4
28	67-6440	Handle - Upper	1

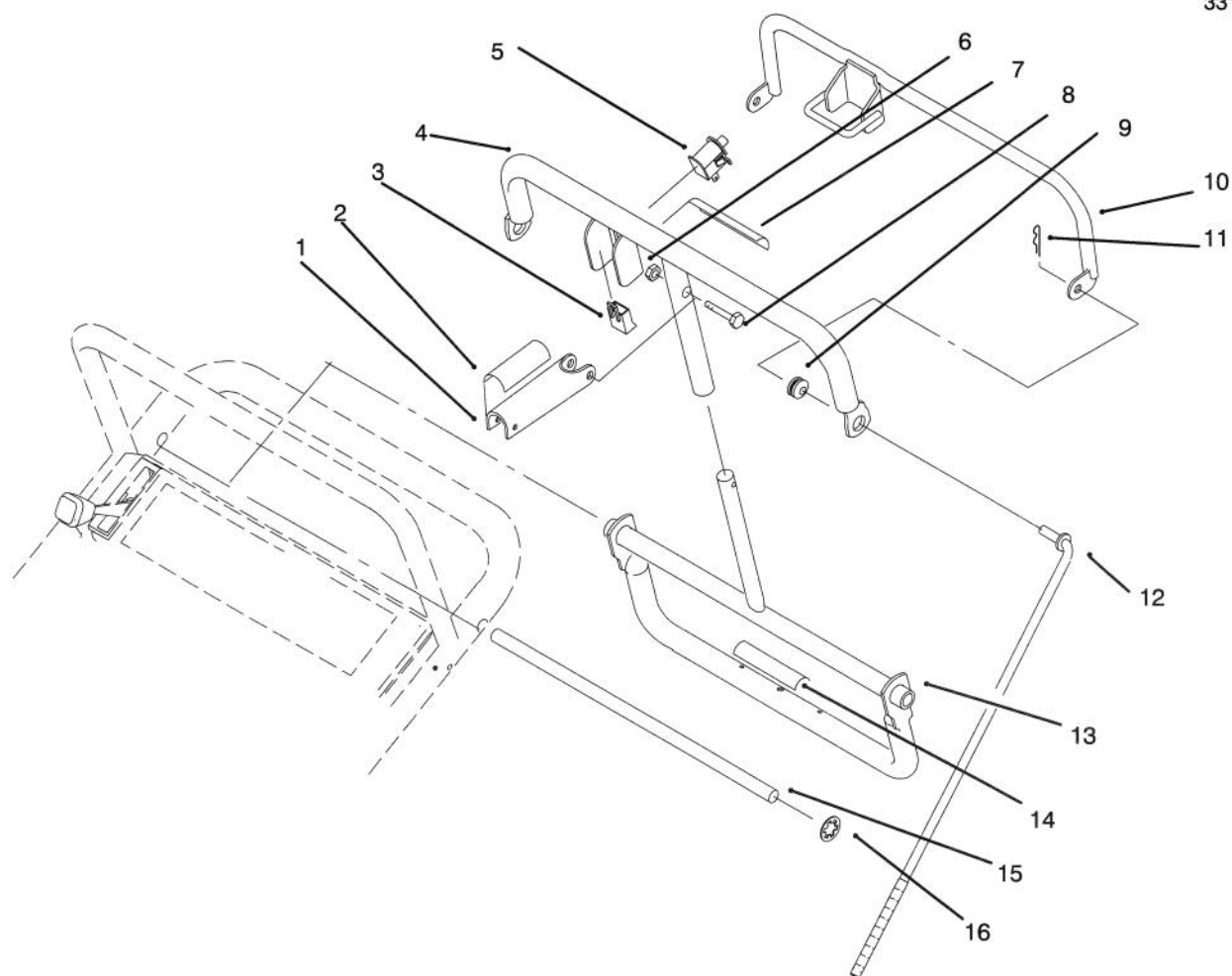

C-2156

HANDLE ASSEMBLY (Continued)

Ref. No.	Part No.	Description	No. Used	Ref. No.	Part No.	Description	No. Used
1	51-4850	Lever - Parking Brake	1	9	237-141	Grommet - Rubber	2
2	52-2010	Decal - Parking Brake	1	10	82-7680	Bail Assembly	1
3	218-595	Connector - Body	1	11	3290-307	Pin - Cotter	2
4	82-7690	Bar - Control	1	12	82-7631	Rod - Control	2
5	82-2190	Switch - Bail	1	13	74-0380	Control - Pivot	1
6	3296-2	Nut - Lock	5	14	82-2280	Decal - Reverse Handle	1
7	82-2290	Decal - Control Bar	1	15	74-0470	Rod - Pivot	1
8	32105-1	Screw - Hex. Hd. Machine	1	16	32151-80	Ring - Push On	2

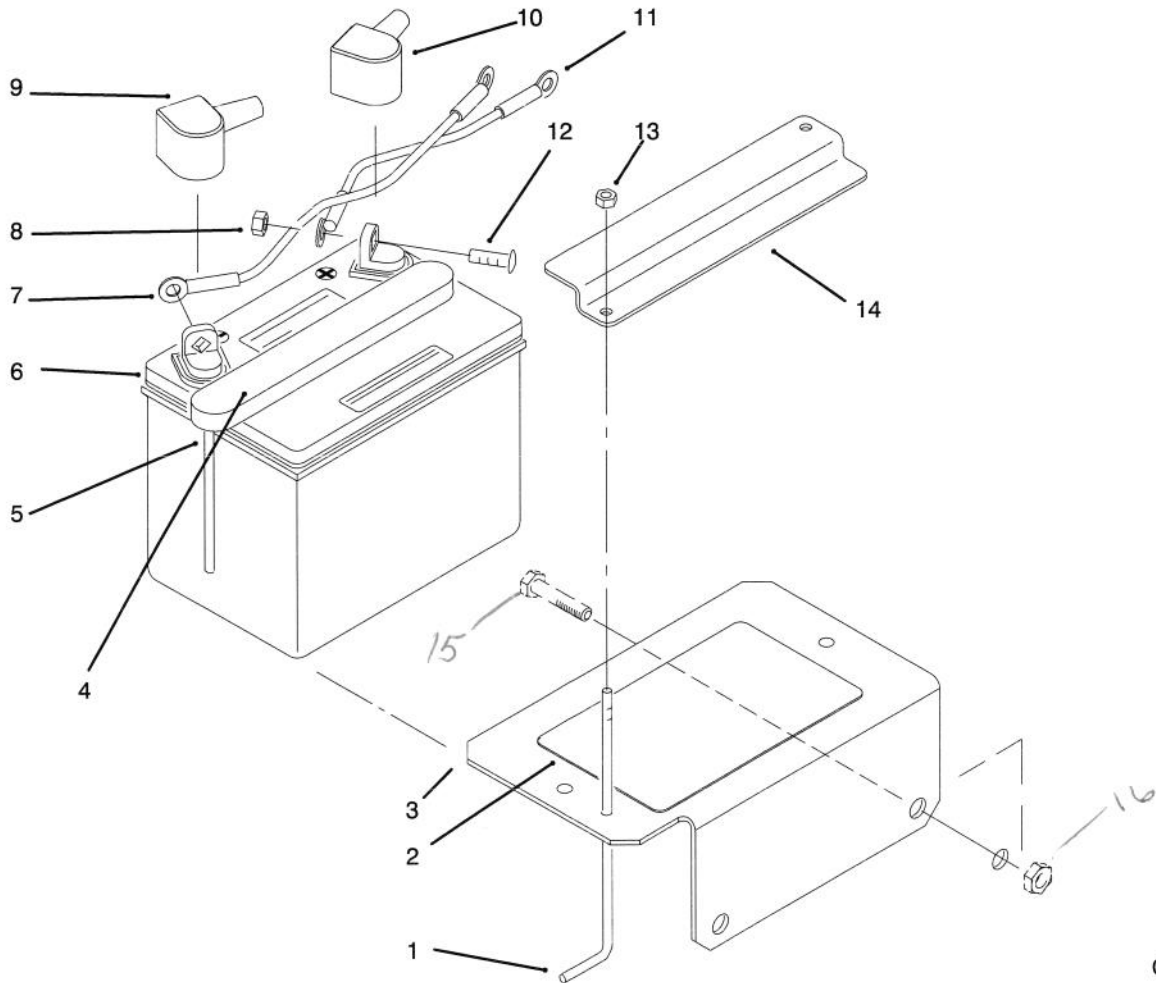

C-2157

BATTERY ASSEMBLY

Ref. No.	Part No.	Description	No. Used
1	12-5950	Rod - Battery Support	2
2	62-4300	Pad - Battery Mount	1
3	93-1180	Holder - Battery	1
4	84-1830	Cap - Battery	1
5	68-3810	Tube - Vent	1
6	82-4640	Battery	1
7	54-3090	Cable - Battery	1

Ref. No.	Part No.	Description	No. Used
8	32149-1	Nut	2
9	77-0980	Boot - Terminal	1
10	77-0981	Boot - Terminal	1
11	28-3891	Cable - Battery	1
12	322-3	Screw - Cap Hex. Hd.	2
13	3296-42	Nut - Lock	2
14	82-4620	Strap - Battery	1
		<i>54-3092</i>	
	<i>15</i>	<i>3234-32 FLANGE HD SCREW</i>	<i>2</i>
	<i>16</i>	<i>32128-23 NUT LOCK</i>	<i>2</i>

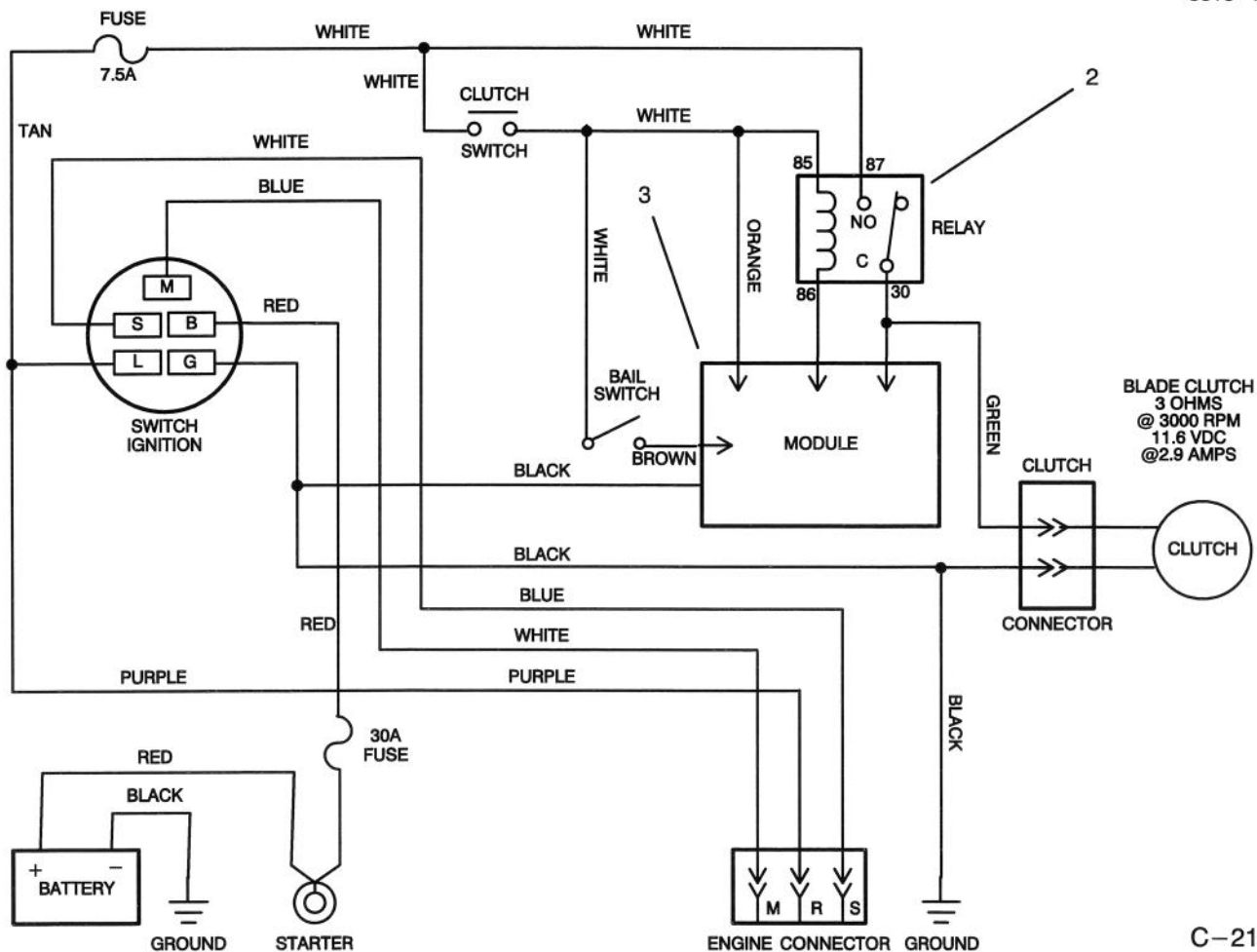

C-2158

ELECTRIC SCHEMATIC

Ref. No.	Part No.	Description	No. Used
1	93-1158	Wire Harness	1
2	63-7590	Relay	1

Ref. No.	Part No.	Description	No. Used
3	86-7910	Module - Interlock	1

*Not Illustrated

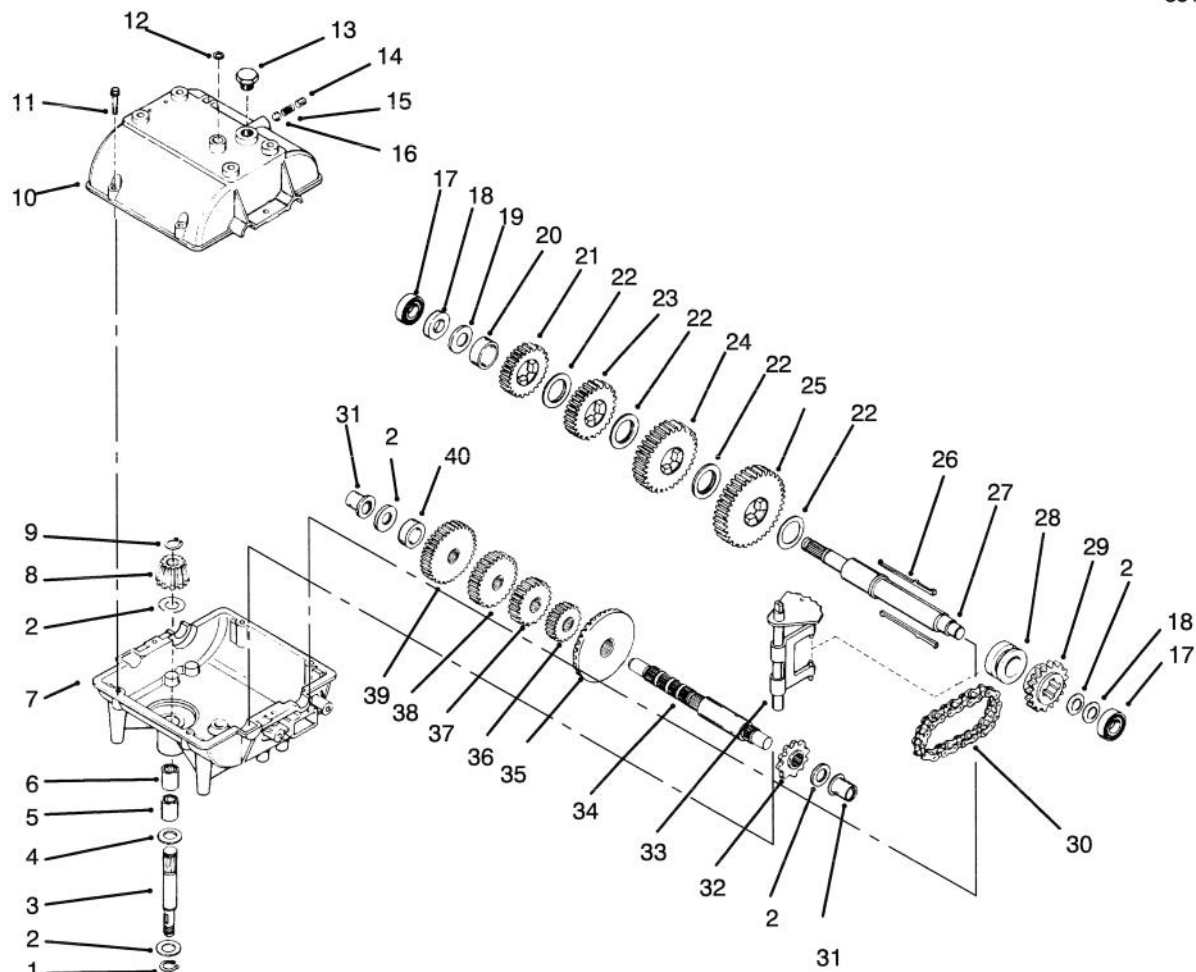

C-1776

PEERLESS TRANSMISSION MODEL NO. 700-039

Ref. No.	Part No.	Description	No. Used
1	792035	Ring - Retaining	1
2	780072	Washer - Thrust	5
3	776135	Shaft - Input	1
4	792001	"O"Ring	2
5	780142	Bearing - Needle	1
6	780086	Bearing - Needle	1
7	770090A	Case - Transmission	1
8	778153	Bevel Pinion - Input	1
9	788040	Ring - Retaining	1
10	772099A	Cover - Transmission	1
11	792073	Screw - Self Tapping	6
12	788069	Seal - Square Cut	1
13	792074	Plug - Threaded	1
14	792078	Screw - Set	1
15	792079	Spring	1
16	792077	Ball - Steel	1
17	780092	Bearing - Ball	2
18	780065	Washer - Thrust	2
19	780139	Washer - Thrust	1
20	786072	Spacer	1
21	778123A	Gear - Spur (25 Teeth)	1

Ref. No.	Part No.	Description	No. Used
22	780108	Washer - Thrust	4
23	778250	Gear - Spur (27 Teeth)	1
24	778124A	Gear - Spur (30 Teeth)	1
25	778125	Gear - Spur (35 Teeth)	1
26	792089A	Key	4
27	776289A	Shaft - Output & Brake	1
28	784266	Collar - Shift	1
29	786083	Sprocket (18 Teeth)	1
30	786081	Chain - Roller (No. 41 Chain 24 Links)	1
31	780105A	Bushing - Flanged	2
32	786082	Sprocket (9 Teeth)	1
33	784267	Rod & Fork Ass'y - Shift	1
34	776134	Shaft - Counter	1
35	778154	Gear - Bevel (42Teeth)	1
36	778136	Gear - Spur (15 Teeth)	1
37	778126A	Gear - Spur (20 Teeth)	1
38	778249	Gear - Spur (23 Teeth)	1
39	778127A	Gear - Spur (25 Teeth)	1
40	786071	Spacer	1

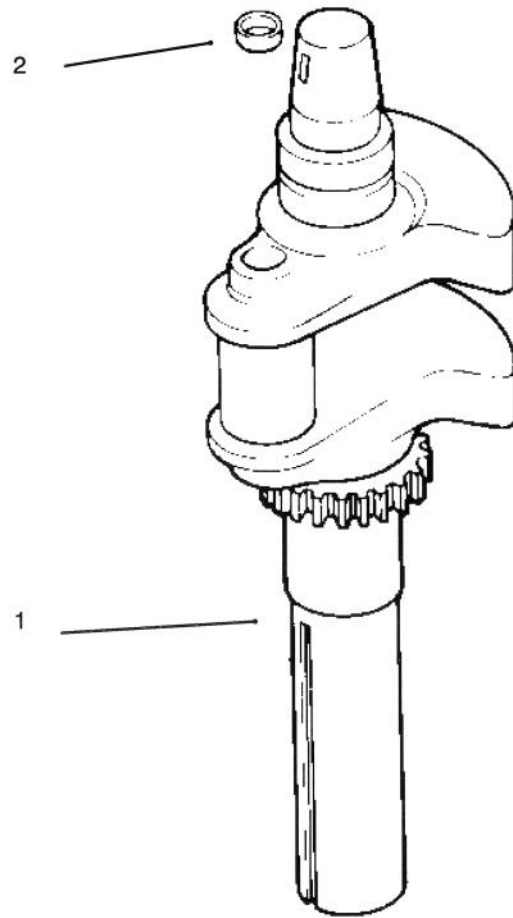

C-2159

CRANKSHAFT

Ref. No.	Part No.	Description	No. Used	Ref. No.	Part No.	Description	No. Used
1	Crankshaft			2	52 139 09	Plug – Cup	
1	24 014 80	Crankshaft	1				

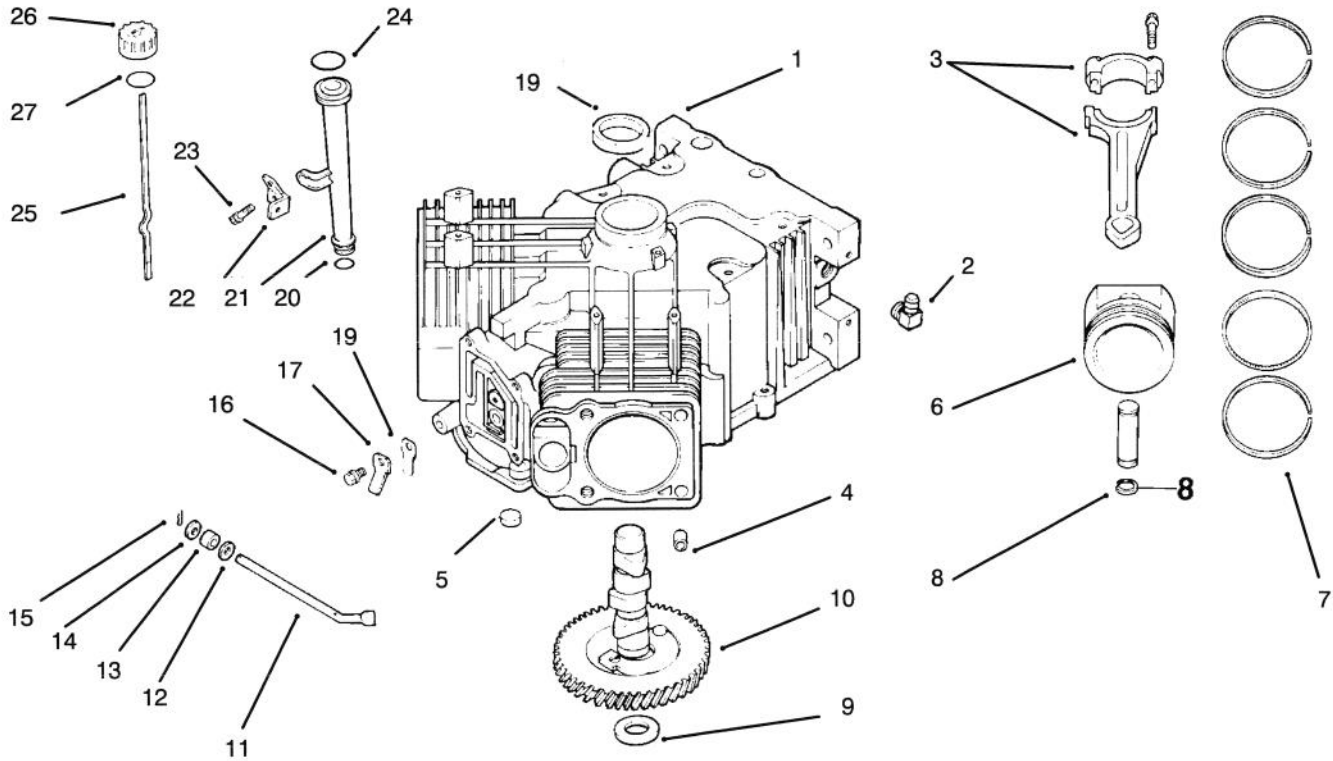

C-2160

CRANKCASE

Ref. No.	Part No.	Description	No. Used
1	24 782 05	Cylinder Block	1
2	24 294 03	Fitting	1
3	24 067 01	Rod – Connecting (Std)	2
*	24 067 02	Rod – Connecting (.25)	2
4	12 380 03	Pin – Locating	6
5	52 139 09	Plug – Cup	1
6	24 874 01	Set – Piston w/Ring (Incl. Ref. #7-8)	2
*	24 874 02	Set – Piston w/Ring (.25) (Incl. Ref. #7-8)	2
*	24 874 03	Set – Piston w/Ring (.50) (Incl. Ref. #7-8)	2
7	24 108 01	Set – Ring (Std)	2
*	24 108 02	Set – Ring (.25)	2
*	24 108 03	Set – Ring (.50)	2
8	24 018 01	Retainer – Piston Pin	4
9	12 422 09	Shim – Camshaft (Green)	A/R
*	12 422 13	Shim – Camshaft (Black)	A/R
*	12 422 07	Shim – Camshaft (White)	A/R
*	12 422 08	Shim – Camshaft (Blue)	A/R
*	12 422 10	Shim – Camshaft (Yellow)	A/R
*	12 422 11	Shim – Camshaft (Red)	A/R

Ref. No.	Part No.	Description	No. Used
*	12 422 12	Shim – Camshaft (Gray)	A/R
10	24 012 05	Camshaft	1
11	24 144 01	Shaft – Governor Cross	1
12	X-25-63	Washer	1
13	12 032 01	Seal – Governor Cross	1
14	X-25-102	Washer	1
15	12 380 04	Pin – Hitch	1
16	M-0545010	Screw	2
17	24 018 04	Retainer – Reed	2
18	24 402 01	Reed – Breather	2
19	24 032 01	Seal – Oil	1
20	12 153 01	"O"Ring	1
21	12 123 04	Tube – Oil Fill	1
22	24 126 19	Bracket – Fill Tube	1
23	M-0549016	Screw	1
24	12 153 02	"O"Ring	1
25	24 038 04	Dipstick Assembly (Incl. Ref. # 26-27)	1
26	25 755 13	Kit – Fill Cap (Incl. Ref. # 27)	1
27	12 153 03	"O"Ring	1

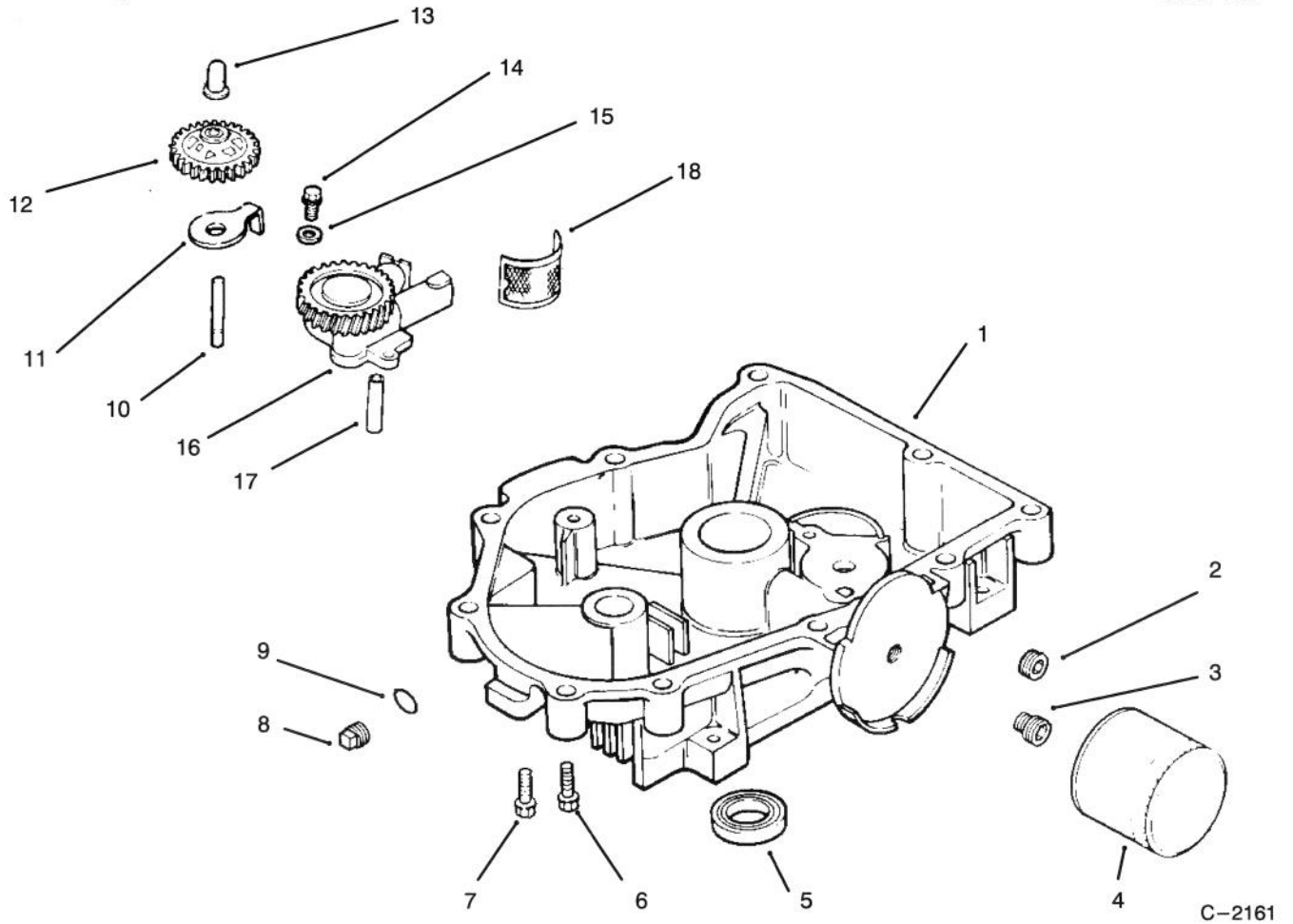

OIL PAN / LUBRICATION

Ref. No.	Part No.	Description	No. Used
1	24 199 04	Pan – Oil	1
2	X-75 32	Plug	1
3	24 136 01	Nipple – Oil Filter	1
4	12 050 01	Filter – Oil	1
5	52 032 08	Seal – Oil	1
6	24 086 17	Screw	1
7	24 086 16	Screw	9
8	X-75-10	Plug	1
9	24 153 08	"O"Ring	1
10	12 144 02	Shaft – Governor Gear	1

Ref. No.	Part No.	Description	No. Used
11	52 448 02	Tab – Locking	1
12	24 043 12	Kit – Governor Gear (Incl. Ref.#13)	1
13	12 380 01	Pin – Governor Regulating	1
14	M-645025	Screw	2
15	SM-0631005	Washer	2
16	24 393 08	Oil Pump Assembly (Incl. Ref.#17)	1
17	24 123 05	Tube – Oil Pickup	1
18	25 162 07	Screen – Oil	1

*Not Illustrated

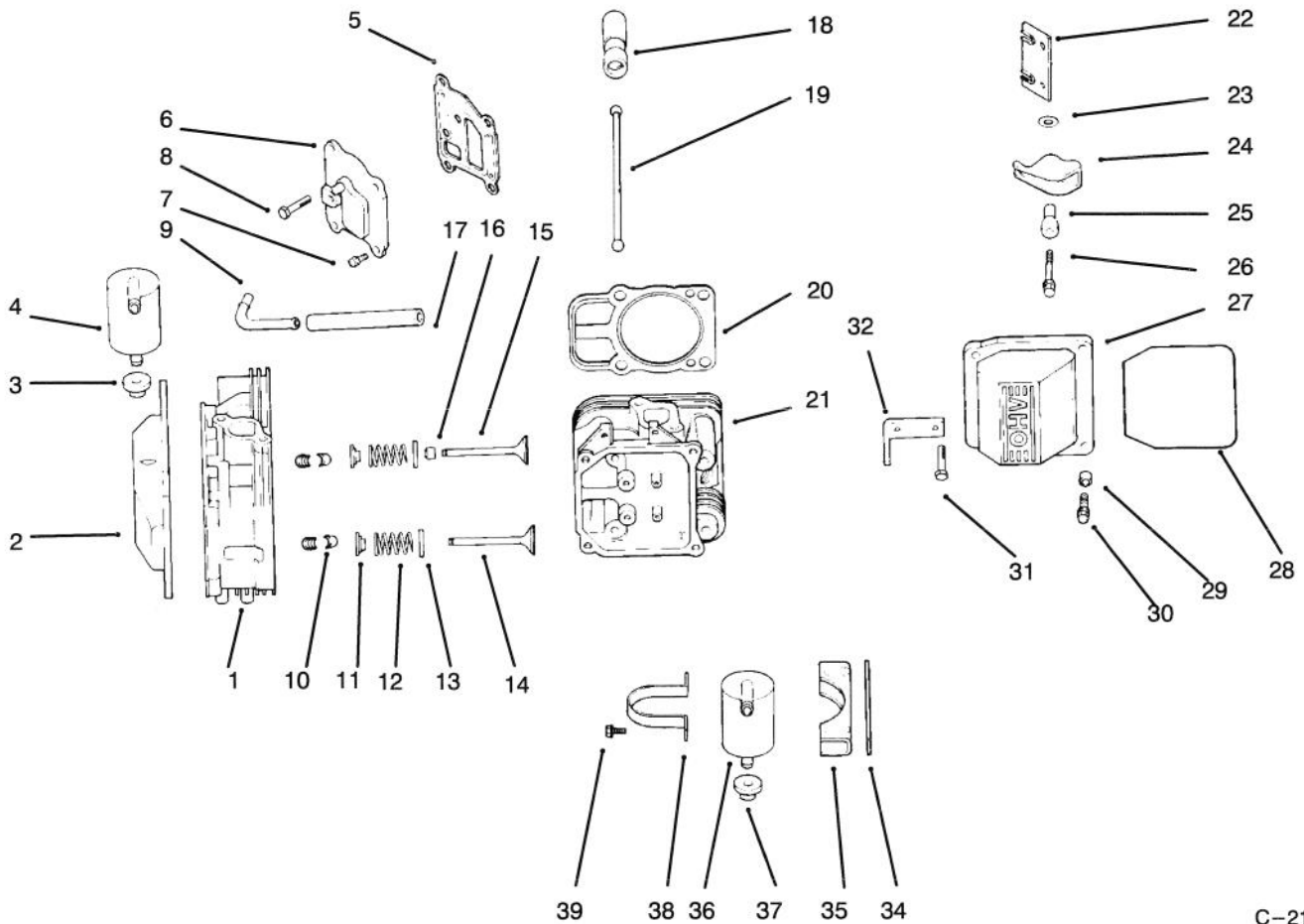

C-2162

HEAD / VALVE / BREATHER

Ref. No.	Part No.	Description	No. Used
1	24 318 11	Head Asm. # 1 Cyl.	1
2	24 755 76	Kit – Valve Cover/Breather (Incl. Ref.# 3 & 28-30)	1
3	25 313 02	Grommet – Rubber	1
4	24 755 20	Kit – Breather (Incl. Ref.# 3)	1
5	24 041 23	Gasket – Breather	1
6	24 096 15	Cover – Breather	1
7	SM-0645020	Screw	4
8	X-75-23	Plug	1
9	24 294 01	Fitting	1
10	12 755 03	Kit – Retaining	4
11	12 173 01	Cap – Valve Spring	4
12	24 089 02	Spring – Valve	4
13	235011	Retainer – Spring	4
14	24 016 01	Valve – Exhaust (Std)	2
*	24 016 02	Valve – Exhaust (.25)	2
15	24 017 01	Valve – Intake (Std)	2
*	24 017 02	Valve – Intake (.25)	2
16	24 032 05	Seal – Valve Stem	2
17	24 326 03	Hose	1
18	12 351 01	Lifter – Valve	4
19	24 411 04	Rod – Push	4

Ref. No.	Part No.	Description	No. Used
20	24 041 08	Gasket – Cylinder Head	2
21	24 318 12	Head Assembly # 2 Cyl.	1
22	24 146 09	Plate – Guide	2
23	SM-0631005	Washer	4
24	24 186 02	Arm – Rocker	4
25	24 194 02	Pivot – Rocker Arm	4
26	M-0640034	Screw	4
27	24 755 74	Kit – Valve Cover (Incl. Ref. # 28-30)	1
28	24 153 11	"O"Ring	1
29	24 112 08	Spacer	4
30	M-0651030	Screw	4
31	12 086 16	Screw	8
32	24 445 01	Strap – Lifting	1
*33	24 755 57	Kit – Breather Separator (Incl. Ref. # 34-39)	1
34	24 112 12	Spacer	1
35	24 126 44	Bracket	1
36	24 595 02	Separator – Oil Breather	1
37	24 313 02	Grommet – Rubber	1
38	24 445 02	Strap – Lifting	1
39	M-0549016	Screw	2

*Not Illustrated

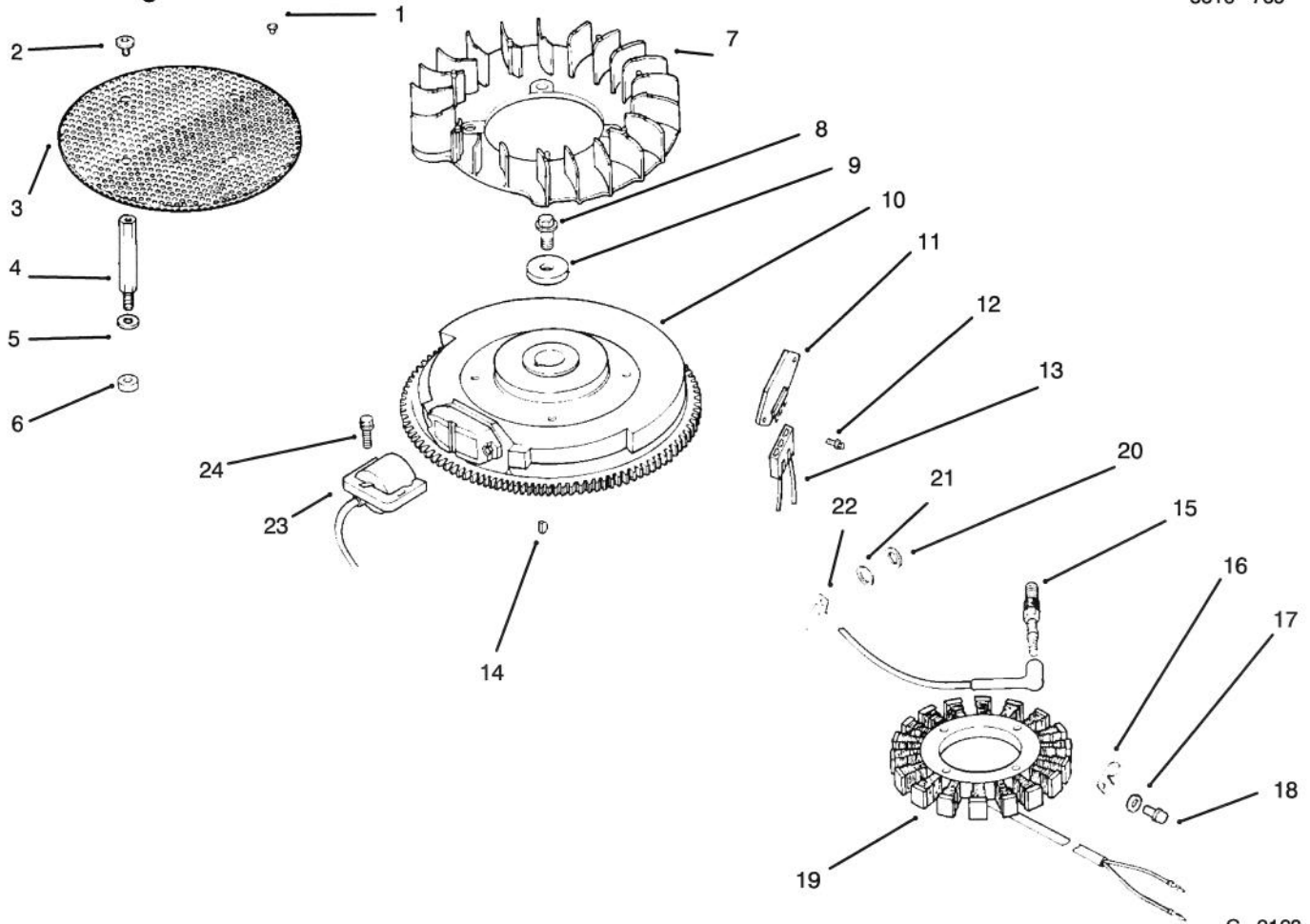

C-2163

IGNITION / ELECTRICAL

Ref. No.	Part No.	Description	No. Used
1	25 086 43	Screw – Set	1
2	M-657010	Screw	4
3	24 162 13	Screen – Grass	1
4	24 072 01	Stud	4
5	X-25-53	Washer	8
6	12 112 01	Spacer – Fan	4
7	24 157 01	Fan	1
8	12 086 14	Screw	1
9	12 468 03	Washer	1
10	24 025 04	Flywheel Assembly	1
11	25 403 03	Rectifier – Regulator	1
12	24 086 18	Screw	2
13	236602	Connector	1

Ref. No.	Part No.	Description	No. Used
14	X-42-15	Key	1
15	12 132 02	Spark Plug	2
16	48 154 02	Clip – Cable	1
17	X-25-63	Washer	1
18	M-0548025	Screw	2
19	24 085 01	Stator – 15 amp	1
20	X-25-92	Washer	2
21	X-25-63	Washer	1
22	235173	Clip – Cable	1
23	24 584 01	Module – Ignition	2
24	SM-0545020	Screw	4
*	24 176 40	Harness – Wiring	1
	24 518 04	Lead – Green	1

*Not Illustrated

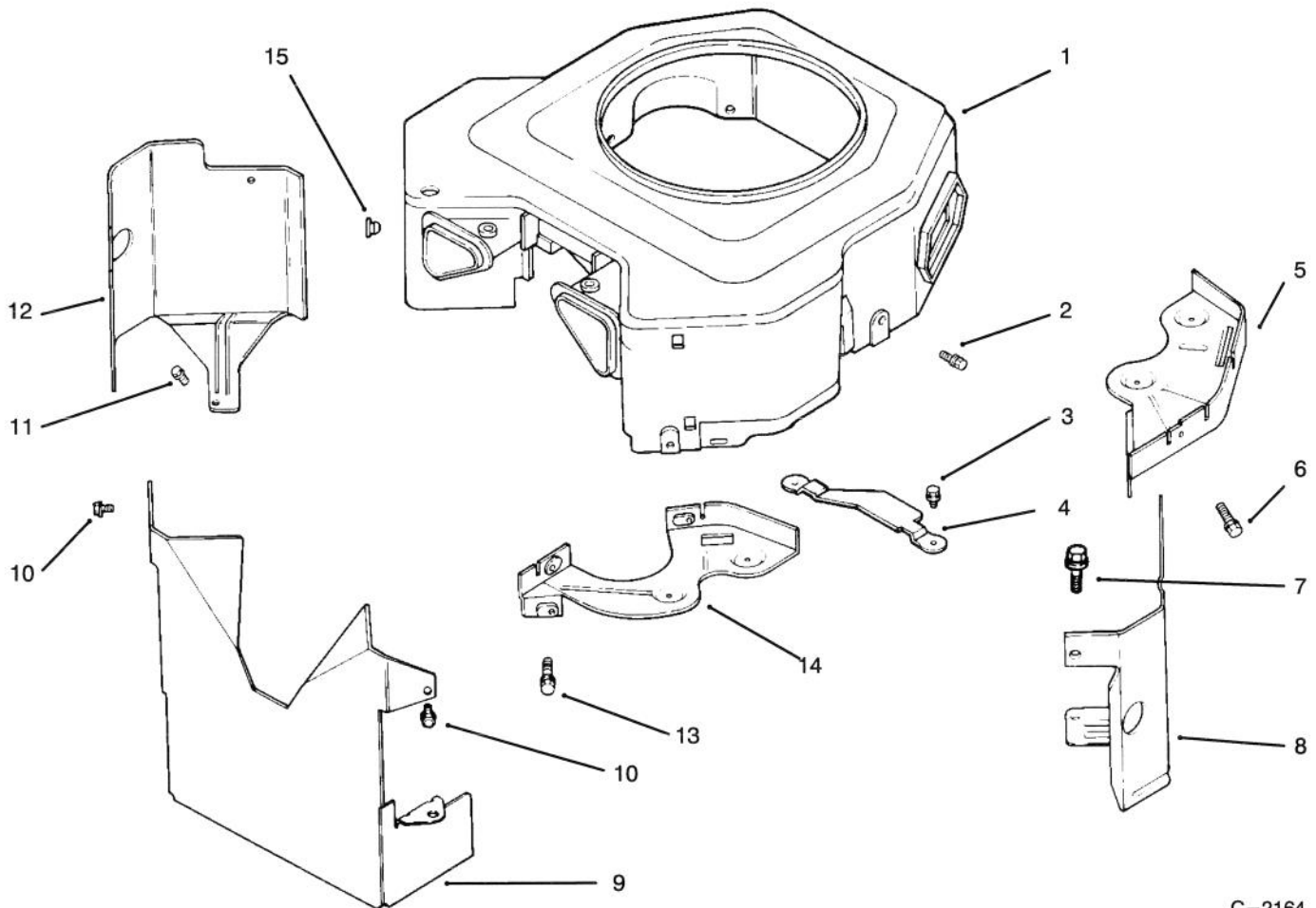

C-2164

BLOWER HOUSING & BAFFLES

Ref. No.	Part No.	Description	No. Used
1	24 027 21	Housing – Blower	1
2	M-0549016	Screw	3
3	SM-0645016	Screw	4
4	24 314 05	Guard – Flywheel	1
5	24 146 02	Plate – Backing # 2 Side	1
6	SM-0545020	Screw	2
7	M-0551016	Screw	1
8	24 063 20	Baffle Cyl. Barrel # 2 Side	1
9	24 063 16	Baffle – Valley	1
10	M-0549010	Screw	2
11	M-0549016	Screw	2
12	24 063 19	Baffle Cyl. Barrel # 1 Side	1

Ref. No.	Part No.	Description	No. Used
13	M-0649016	Screw	2
14	24 146 08	Plate – Backing # 1 Side	1
15	24 100 02	Nut – Plastic	2
*	24 100 01	Nut – Plastic (Incl. w/Blower Housing)	3
*	24 100 02	Nut – Plastic (Incl. w/Blower Housing)	2
*	24 086 43	Screw – Set (Incl. w/Blower Housing)	1
*	25 139 16	Plug – Button (Incl. w/Blower Housing)	1
*	24 113 11	Decal – Horse Power	1

* Not Illustrated

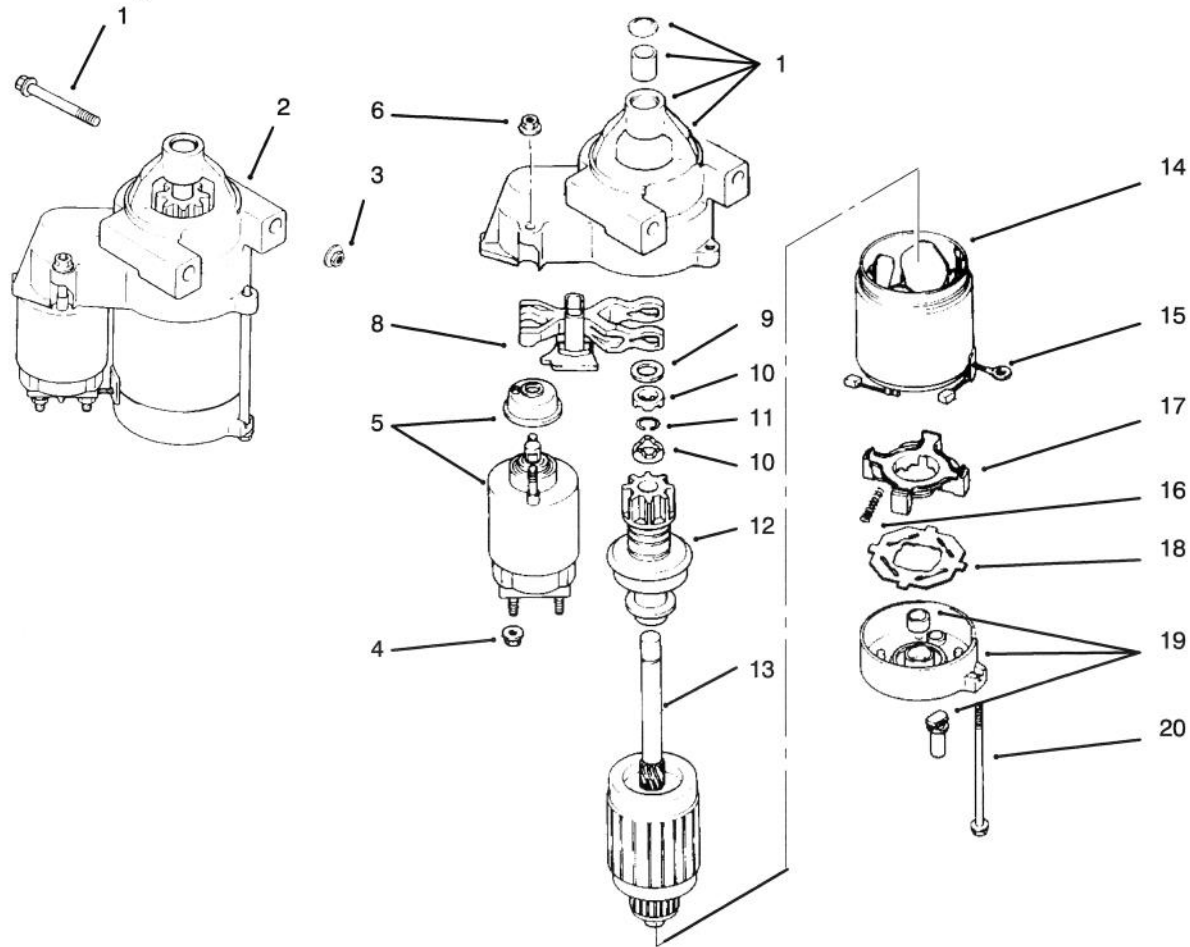

C-2165

STARTING SYSTEM

Ref. No.	Part No.	Description	No. Used	Ref. No.	Part No.	Description	No. Used
1	M-0839080	Screw	2	11	52 141 03	Ring – Retaining	1
2	12 098 03	Starter Solenoid Shift (Incl. Ref. #4-20)	1	12	12 239 01	Pinion – Drive	1
3	M-0841080	Nut	1	13	12 170 03	Armature – Starter	1
4	52 100 10	Nut	2	14	12 471 01	Frame	1
5	12 081 02	Cap – Drive End	1	15	52 221 01	Kit – Brush (Incl. Ref. #16)	1
6	52 100 09	Nut	1	16	52 089 09	Spring – Brush	4
7	52 435 02	Solenoid	1	17	52 323 03	Holder – Brush	1
8	12 090 10	Lever – Starter Drive	1	18	52 168 01	Insulator	1
9	52 468 14	Washer	1	19	12 301 01	Cap – Commutator End	1
10	52 100 08	Nut	2	20	52 211 05	Bolt	2

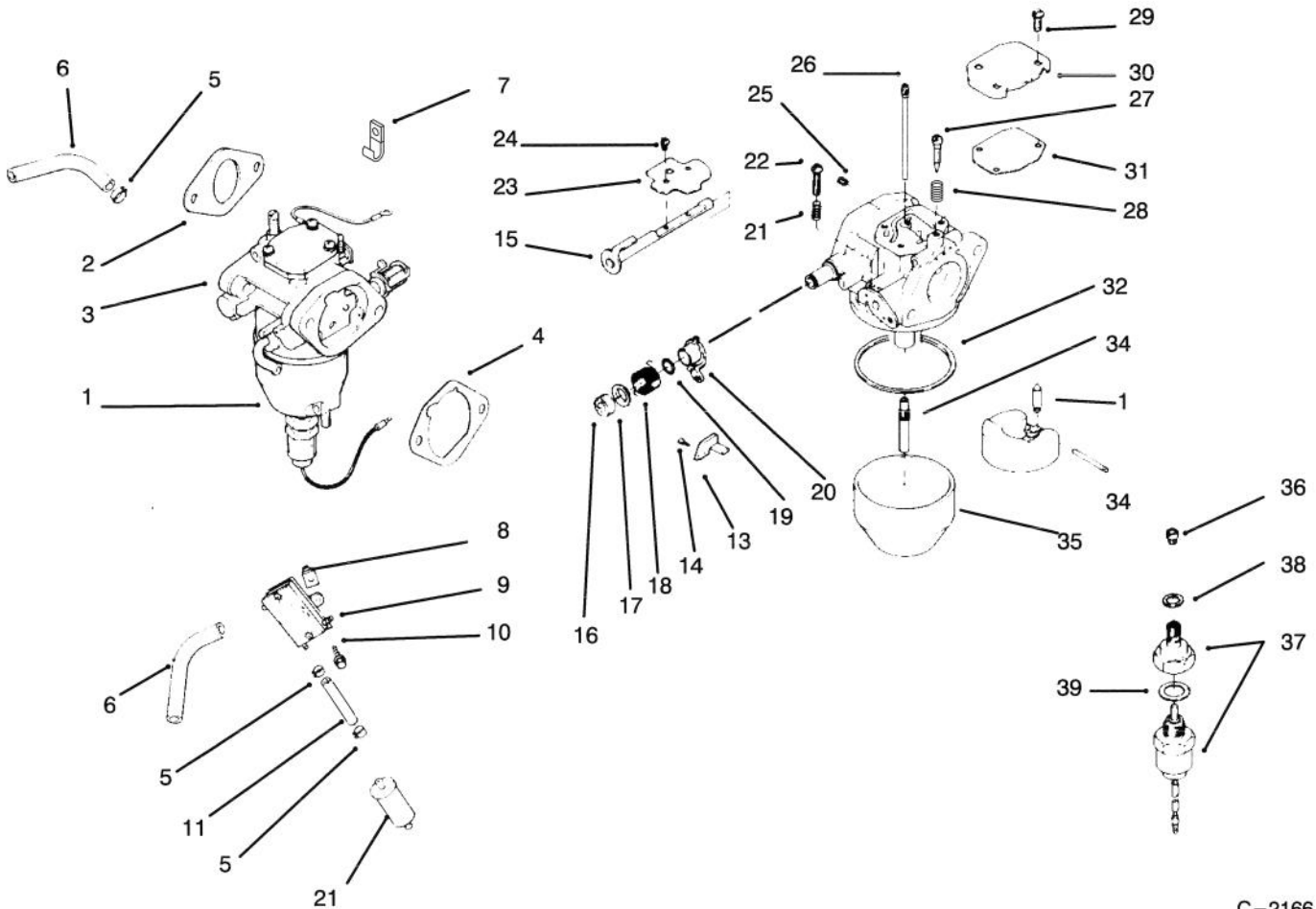

C-2166

CARBURETOR / FUEL PUMP

Ref. No.	Part No.	Description	No. Used
1	24 853 22	Kit – Carburetor (Incl. Ref.#2-4)	1
2	24 041 15	Gasket – Carburetor	1
3	24 053 17	Carburetor (Ref. Only) (Inc. Ref. 15-39)	1
4	24 041 14	Gasket – Air Cleaner	1
5	X-426-9	Clamp – Hose	6
6	52 353 22	Line – Fuel 12”	2
7	47 154 01	Clip – Cable	1
8	24 100 01	Nut – Plastic	2
9	24 393 04	Pump – Fuel	1
10	24 086 12	Screw	2
11	24 353 03	Line – Fuel 10.5”	1
12	25 050 03	Filter – Fuel	1
13	24 126 29	Bracket – Throttle Stop	1
14	M-0259006	Screw	1
15	24 144 15	Shaft – Choke	1
16	24 468 05	Washer	1
17	24 241 01	Collar – Coke	1
18	24 089 22	Spring – Choke Return	1
19	24 141 04	Ring – Choke Lever	1
20	24 090 10	Lever – Choke	1
21	24 089 24	Spring – Throttle Adjust	1
22	24 086 19	Screw – Throttle Adjust	1
23	24 462 02	Valve – Choke	1

Ref. No.	Part No.	Description	No. Used
24	24 086 20	Screw	4
25	24 337 27	Jet – Air Bleed	1
26	24 337 11	Jet – Slow	1
27	24 086 22	Screw	1
28	24 089 23	Spring – idler Screw	1
29	24 086 21	Screw	3
30	24 096 13	Cover – Passage	1
31	24 041 18	Gasket – Passage Cover	1
32	24 041 19	Gasket – Float Chamber	1
33	24 757 05	Kit – Float Repair	1
34	24 369 01	Nozzle – Main	1
35	24 234 01	Chamber – Float	1
36	24 337 20	Jet – Main	1
37	24 755 15	Kit – Solenoid Valve (Incl. Ref. #38-39)	1
38	24 041 21	Gasket – Chamber Screw	1
39	24 041 20	Gasket – Solenoid	1
	X-25-52	Washer	1
*	24 041 15	Gasket – Carburetor	1
*	24 755 25	Kit – High Altitude (1500-3000 Meters)	1
*	24 755 26	Kit – High Altitude (over 3000 Meters)	1
*	24 757 06	Kit – Carburetor Repair	1

* Not Illustrated

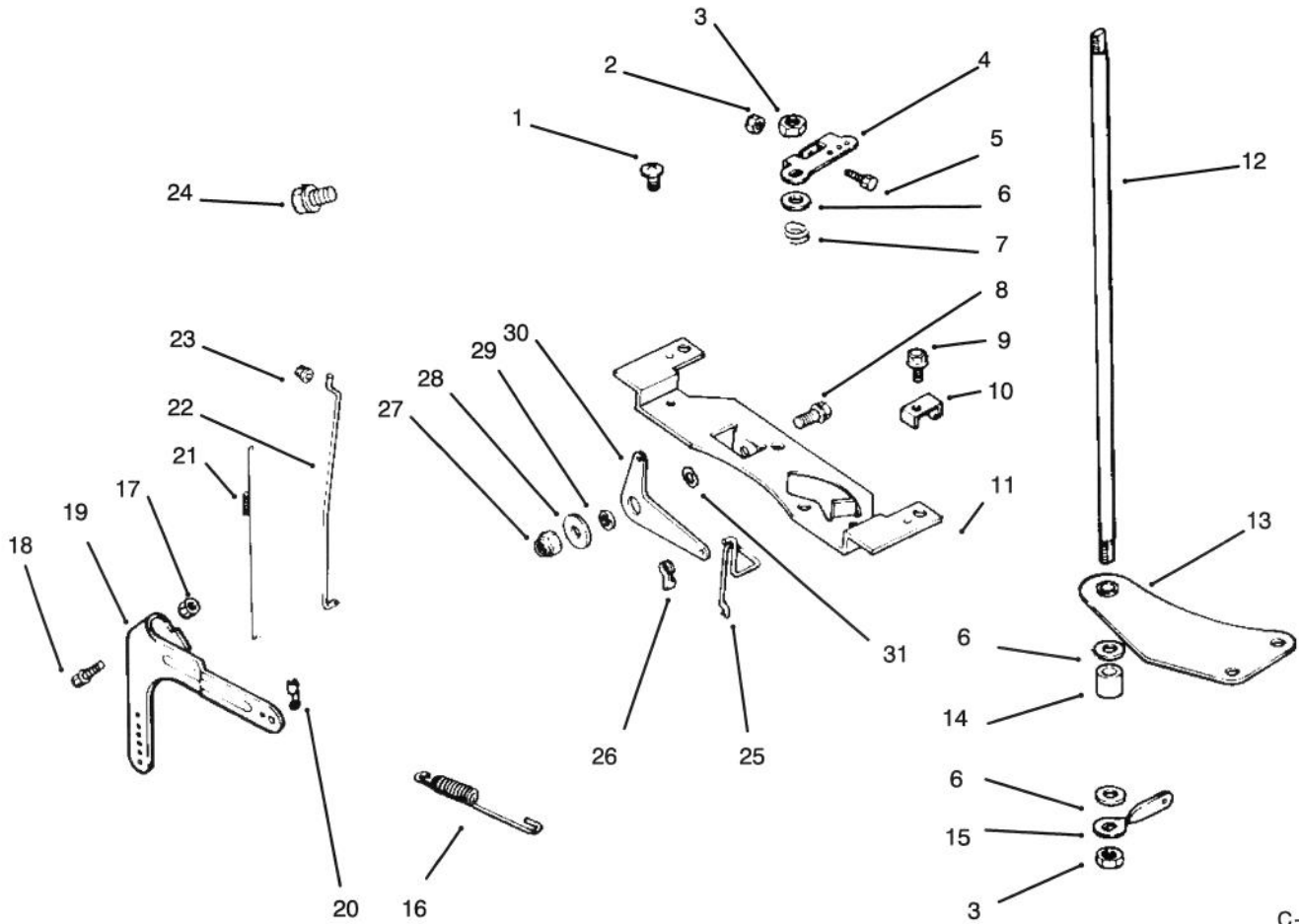

C-2167

ENGINE CONTROLS

Ref. No.	Part No.	Description	No. Used
1	24 086 06	Screw	2
2	M-0446030	Nut	1
3	M-0647060	Nut	2
4	24 090 09	Lever – Throttle Control	1
5	M-0401030	Screw	1
6	X-25-72	Washer	3
7	24 089 20	Spring – Throttle Shaft	1
8	M-0639016	Screw	1
9	SM-054016	Screw	1
10	12 237 01	Clamp – Cable	2
11	24 126 47	Bracket – Control	1
12	24 144 11	Shaft – Throttle	1
13	24 126 17	Bracket – Throttle Shaft	1
14	52 122 13	Spacer	1
15	24 090 12	Lever – Throttle Control	1
16	24 089 18	Spring – Governor	1

Ref. No.	Part No.	Description	No. Used
17	SM-0641060	Nut	1
18	SM-0642025	Screw	1
19	24 090 14	Lever – Governor	1
20	25 158 11	Bushing – Throttle	1
21	24 089 01	Spring – Linkage	1
22	24 079 04	Linkage – Throttle	1
23	25 158 08	Bushing – Linkage	1
24	SM-0645016	Screw	2
25	24 079 08	Linkage – Choke	1
26	25 158 11	Bushing – Throttle	1
27	M-0647060	Nut	1
28	X-25-52	Washer	1
29	25 431 01	Spacer	1
30	24 090 20	Lever – Choke	1
31	277341	Washer	1

*Not Illustrated

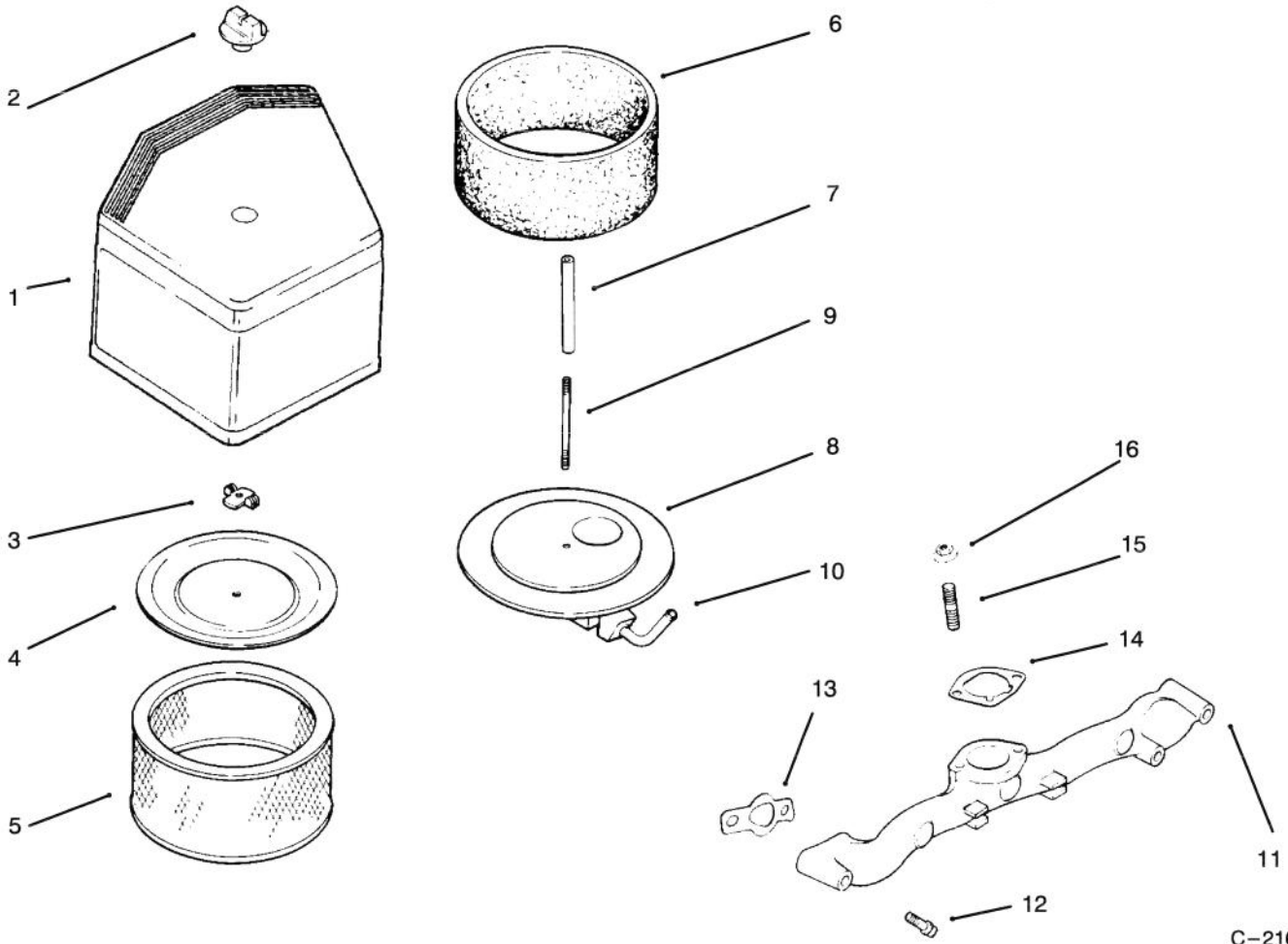

C-2168

AIR CLEANER / FILTRATION

Ref. No.	Part No.	Description	No. Used
1	24 743 10	Kit – Air Cleaner Cover (Incl. Ref.# 2)	1
2	25 341 02	Knob – Cover	1
3	12 100 01	Nut – Wing	1
4	52 082 04	Cover – Element	1
5	45 083 01	Element – Precleaner	1
6	45 083 02	Element	1
7	24 032 04	Seal	1
8	24 054 02	Elbow – Air Cleaner (Incl. Ref. # 9-10)	1

Ref. No.	Part No.	Description	No. Used
9	24 072 04	Stud	1
10	24 294 01	Fitting	1
11	24 164 06	Manifold – Intake	1
12	M-0639055	Screw	4
13	24 041 01	Gasket – intake Manifold	2
14	24 041 14	Gasket – Air Cleaner Base	1
15	M-0629128	Stud	2
16	SM-0641060	Nut	2
*	24 113 14	Decal – Maintenance	1

*Not Illustrated

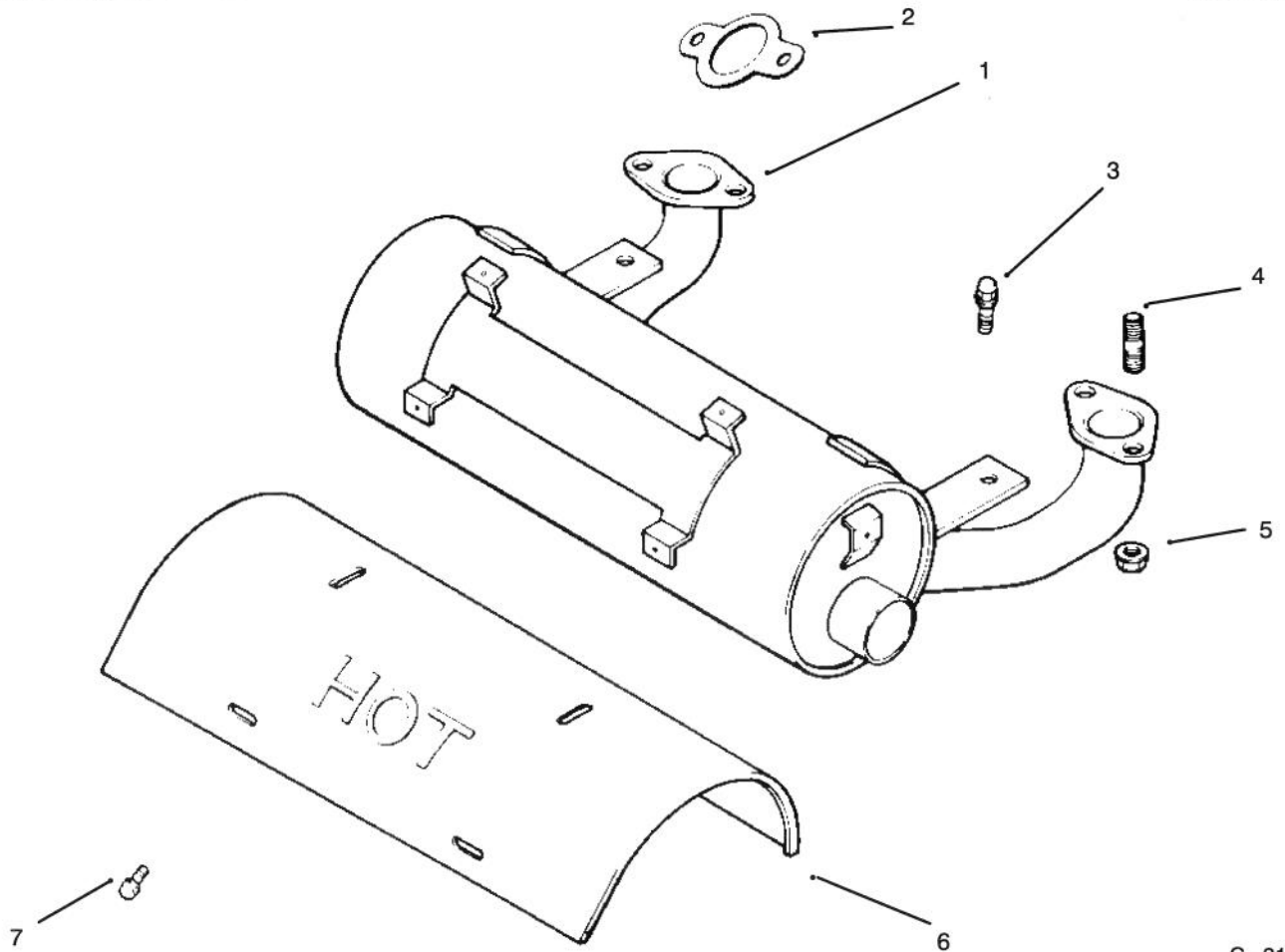

C-2169

EXHAUST

Ref. No.	Part No.	Description	No. Used
1	24 068 08	Muffler	1
2	24 041 02	Gasket – Exhaust	2
3	SM-0645020	Screw	2
4	M-0829033	Stud	4
5	M-0841080	Nut	4

Ref. No.	Part No.	Description	No. Used
6	24 281 07	Duct – Heat Shield	1
7	25 086 40	Screw	4
*	24 782 05	Miniblock	1
*	24 755 03	Gasket Set	1

*Not Illustrated

TORO PART NUMBER INDEX

Part No.	Description	Pg. Ref. No. No. Qty.	Part No.	Description	Pg. Ref. No. No. Qty.
112843	Washer - Clutch	4 15 1	67-6380	Bracket - Support L.H.	1 14 1
5-0930	Key	4 10 1	67-6440	Handle - Upper	6 28 1
7-5461	Spacer	2 3 1	68-2190	Spring - Extension	2 18 18
10-8110	Washer - Flat	3 17A/R	68-3810	Tube - Vent	8 5 1
12-5950	Rod - Battery Support	8 1 2	68-9690	Fitting - Rod	1 6 2
16-7509	Lever - Idler	2 21 1	71-1280	Decal - Danger	6 7 1
23-0660	Switch - Ignition	6 16 1	72-2190	Mount - Shift Lever	2 1 1
26-9670	Belt - Traction	2 12 1	74-0040	Spacer - Pivot Idler	1 23 4
27-6230	Bolt	2 19 1	74-0050	Sheave - Lower Half	4 13 1
28-3891	Cable - Battery	8 11 1	74-0060	Sheave - Upper Half	4 12 1
44-8310	Ring - Retaining	5 3 2	74-0220	Idler - Bracket L.H.	1 20 1
44-8320	Spring	5 10 3	74-0230	Idler - Bracket R.H.	1 * 1
44-8330	Spacer	5 6 1	74-0320	Lever - Shift	2 2 1
44-8340	Collar - Bearing	5 7 1	74-0360	Frame - Rear	1 27 1
44-8360	Field Coil, Rotor & Bearing	5 4 1	74-0380	Control - Pivot	7 13 1
47-1970	Grip - Engagement	2 5 1	74-0470	Rod - Pivot	7 15 1
47-2982	Hose - Fuel	1 28 1	74-0480	Pulley - Drive	3 7 2
51-4160	Pulley - Wheel	3 19 4	74-0490	Decal - Fuel Shut Off	1 31 1
51-4170	Spacer - Pulley	3 20 8	74-0510	Valve - Fuel	1 30 1
51-4180	Drum - Brake	3 22 2	74-0521	Fitting - Rod	1 13 2
51-4190	Pulley - Driven	2 13 1	74-0610	Transmission	2 17 1
51-4220	Guard - Coupler	2 8 2	74-0720	Tube - Manual	6 1 1
51-4230	Washer - Wheel	3 29 2	77-0980	Boot - Terminal	8 9 1
51-4240	Shaft - Extension R.H.	3 5 1	77-0981	Boot - Terminal	8 10 1
51-4250	Shaft - Extension L.H.	3 * 1	82-2180	Panel - Control	6 4 1
51-4260	Coupler	2 7 1	82-2190	Switch - Bail	7 5 1
51-4270	Bearing - Shaft Extension	3 1 2	82-2280	Decal - Reverse Handle	7 14 1
51-4290	Belt - Drive	3 11 2	82-2290	Decal - Control Bar	7 7 1
51-4370	Spring - Torsion R.H.	1 * 1	82-2300	Switch - Clutch	6 9 1
51-4380	Spring - Torsion L.H.	1 22 1	82-3820	Boot	6 8 1
51-4450	Screw - Leveler	1 21 2	82-4620	Strap - Battery	8 14 1
51-4480	Idler - Wheel	1 18 2	82-4640	Battery	8 6 1
51-4490	Spacer - Idler Wheel	1 19 2	82-7631	Rod - Control	7 12 2
51-4540	Retainer - Clutch	4 9 1	82-7680	Bail Assembly	7 10 1
51-4580	Rod - Brake	3 3 2	82-7690	Bar - Control	7 4 1
51-4600	Brake Arm R.H.	3 * 1	82-7740	Decal - Proline	6 2 1
51-4610	Brake Arm L.H.	3 9 1	82-7750	Decal - Ground Speed	1 7 1
51-4650	Link - Brake	3 21 2	82-8440	Tank - Fuel	1 2 1
51-4660	Plate - Link Brake	3 26 2	84-1830	Cap - Battery	8 4 1
51-4700	Brake Band Assembly	3 23 2	86-7910	Module - Interlock	9 3 1
51-4850	Lever - Parking Brake	7 1 1	86-7910	Module - Interlock	6 18 1
52-2010	Decal - Parking Brake	7 2 1	92-1746	Bearing	3 14 4
52-2890	Bushing	1 5 2	93-1156	Frame	1 26 1
54-0230	Field Ass'y	5 1 1	93-1168	Engine	4 1 1
54-2750	V-Belt - Deck Drive	3 * 1	93-1176	Spacer - Engine	4 19 2
54-2970	Spacer	6 12 2	93-1177	Spacer - Pulley	4 11 1
54-3090	Cable - Battery	8 7 1	93-1180	Holder - Battery	8 3 1
54-3200	Clutch Assembly	4 14 1	93-1187	Panel - Bottom	6 19 1
55-3570	Cap - Fuel Tank	1 1 1	93-1190	Control - Throttle	6 14 1
55-7410	Armature & Pulley Assemble	5 5 1	93-1190	Control - Throttle	6 14 1
55-7660	V-Belt - Deck Drive	3 * 1	93-1191	Control - Choke	6 3 1
62-4300	Pad - Battery Mount	8 2 1	218-461	Nut	6 6 1
62-4540	Pulley - Idler	2 22 1	218-595	Connector - Body	7 3 1
63-7590	Relay	9 2 1	231-117	Tire	3 12 2
63-7590	Relay	6 21 1	232-27	Valve Stem	3 16 2
63-8360	Key	6 5 2	237-124	Grommet	1 25 1
65-3090	Decal - Instruction	6 10 1	237-141	Grommet - Rubber	7 9 2
66-7400	Plate - Control	1 8 1	242-80	Rim	3 15 2
67-6370	Bracket - Support R.H.	1 * 1	2412-98	Clamp - Fuel line	1 29 1

*Not Illustrated

TORO PART NUMBER INDEX (Cont.)

3316-769

Part No.	Description	Pg. Ref. No. No. Qty.	Part No.	Description	Pg. Ref. No. No. Qty.
2412-120	RClamp	6 24 2	3256-23	Washer - Plain	4 17 6
251-291	Bearing - Pulley	5 8 1	3257-5	Key - Woodruff	3 4 3
251-292	Bearing - Field	5 2 1	3290-307	Pin - Cotter	3 8 2
256-155	Bushing	2 24 2	3290-307	Pin - Cotter	1 11 4
283-6	Pin - Clevis	1 12 2	3290-307	Pin - Cotter	7 11 2
288-4	Pipe Cap	4 4 1	3290-378	Cable Tie	6 26 3
289-42	Pipe Nipple	4 2 1	3296-2	Nut - Lock	7 6 5
2811-10	Elbow - 90° Street	4 3 1	3296-2	Nut - Lock	6 11 5
302-5	Fitting - Grease	2 6 2	3296-5	Nut - Lock	5 9 3
302-11	Fitting - Grease	3 13 2	3296-6	Nut	2 25 1
321-3	Screw - Hex Hd. Cap	6 20 2	3296-23	Nut - Lock	1 17 2
321-4	Screw - Hex. Hd. Cap	3 2 4	3296-39	Nut - Lock	2 20 2
322-2	Screw - Hex. Hd. Cap	2 15 4	3296-39	Nut - Lock	1 24 8
322-3	Screw - Cap Hex. Hd.	8 12 2	3296-42	Nut - Hex	6 17 2
322-4	Screw - Hex. Hd. Cap	1 10 4	3296-42	Nut - Lock	2 9 4
322-7	Screw - Hex. Hd. Cap	3 25 8	3296-42	Nut - Lock	8 13 2
322-9	Screw - Hex. Hd.	4 18 2	32103-25	Nut - Wing	1 3 2
322-10	Screw - Hex. Hd. Cap	4 5 2	32105-1	Screw - Hex. Hd. Machine	7 8 1
323-6	Screw - Hex. Hd. Cap	1 16 6	32105-14	Screw - Hex. Hd. Machine	6 13 4
323-8	Screw - Hex. Hd.	2 23 1	32120-64	Ring - Retaining	2 10 3
323-16	Screw - Hex. Hd. Cap	1 15 2	32128-21	Nut - Lock	6 27 4
329-10	Screw - Hex. Hd. Cap	2 4 1	32144-19	Screw - Self Tapping	6 25 4
3212-24	Screw - Hex. Hd. Cap	4 16 1	32149-1	Nut	8 8 2
3234-11	Screw - Hex. Hd. Cap	6 23 4	32149-1	Nut - Lock	4 8 1
3241-5	Screw - Socket Hd. Cap	2 11 1	32151-40	Ring - Retaining	3 10 2
3245-3	Screw - Socket Hd. Set	3 6 2	32151-56	Ring - Retaining	3 28 2
3253-4	Washer - Lock	1 9 4	32151-72	Ring - Retaining	3 27 4
3253-4	Washer - Lock	2 16 12	32151-80	Ring - Push On	7 16 2
3253-4	Washer - Lock	3 24 12	32151-91	Ring - Retaining	3 18 2
3254-5	Washer - Lock	6 15 1	32152-1	Nut	4 20 3
3255-8	Washer - External Tooth	4 6 1	32153-3	Nut - Lock	4 7 1
3256-23	Washer - Flat	1 4 9			

*Not Illustrated

PRODUCT CHANGES

In an effort to make improvements available to TORO owners as quickly as possible, minor changes are incorporated into Toro's products from time to time that do not become immediately shown in the Parts Catalog. If such a change has been made in your unit, which is not reflected in your manual, see your TORO Distributor or his Authorized TORO Service Dealer for information and part numbers.

IDENTIFICATION AND ORDERING

MODEL AND SERIAL NUMBERS

The Proline 30181 has two identification numbers; a model number and a serial number. The two numbers are stamped on a plate which is located on the main frame. In any correspondence concerning the Proline 30181, supply model and serial numbers to assure that correct information and replacement parts are obtained.

To order replacement parts from an Authorized TORO Service Dealer, supply the following information:

1. Model and serial number of the Proline 30181.
2. Part number, description, and the quantity of part(s) desired.

NOTE: Do not order by reference number if a parts catalog is being used; use the PART NUMBER.

TABLE OF CONTENTS

Description	Page	Description	Page
Frame, Fuel Tank And Wheel Drive Idler	1	Crankcase	12
Transmission, Idler, Drive Pulleys & Belts	2	Oil Pan / Lubrication	13
Axle, Brake And Wheel Drive And Belts	3	Head / Valve / Breather	14
Engine And Clutch Assembly	4	Ignition / Electrical	15
Clutch Assembly No. 54-3200	5	Blower Housing & Baffles	16
Handle Assembly	6-7	Starting System	17
Battery Assembly	8	Carburetor / Fuel Pump	18
Electric Schematic	9	Engine Control	19
Peerless Transmission Model 700-039	10	Air Cleaner Filtration	20
Kohler Engine CV18S PS 61521		Exhaust	21
Crankshaft	11	Toro Numeric Parts Index	22

Optional Equipment

Description	Model / Part No.	Description	Model / Part No.
36" Cutting Unit	Model No. 30136	37" Deck (Cloth Bag) Bag Kit	Model No. 30129
37" Recycler Deck	Model No. 30137	37" Deck (Steel Hopper) Bag Kit ..	Model No. 30130
44" Cutting Unit	Model No. 30144	44"/52" Deck Bag Kit	Model No. 30128
48" Recycler Deck	Model No. 30148	2"-5" HOC Kit	Part No. 84-5010
52" Cutting Unit	Model No. 30152	Front Weight Kit-36"/37" Deck ..	Part No. 80-3350
62" Cutting Unit	Model No. 30162	Standard Sulky	Model No. 30122
36" Deck Bag Kit	Model No. 30125	Steerable Sulky	Model No. 30123