



Greensmaster® Flex™ 21 Mower

Model No. 04022 - 290000001 and up.

Parts Catalog

Ordering Replacement Parts

To order replacement parts, please supply the part number, the quantity, and the description of each part desired.

Understanding Reference Numbers

Each identified part in an illustration has a reference number. The reference number for a part also appears in the parts list, along with other information about the part.

This catalog uses two special reference number formats, one to indicate parts in a service assembly and another to indicate the quantity of a given part in an illustration.

Service Assembly Reference Numbers

Parts in service assemblies have reference numbers in the form a:b. The a represents the reference number of the entire service assembly and the b represents a sequential number unique to each part within the service assembly.

For example, a wheel assembly might be identified by reference number 6, the tire by 6:1, the valve by 6:2, and the wheel by 6:3. When you order the assembly identified by reference number 6, you receive all parts identified by reference numbers 6:1, 6:2, and 6:3. However, you may also order any part individually. Reference numbers of this type appear in illustrations and in part lists.

Reference Numbers Indicating Quantity

In an illustration, if a reference number indicates more than one part, the reference number has the form nX y. The n represents the quantity of the part, the X is the multiplication symbol, and the y represents the reference number.

For example, in an illustration, the reference number 2X 37 means that two of the parts identified by reference number 37 are indicated.

Contents

Description	Page	Description	Page
Frame Assembly 3	Lubrication Equipment Assembly 15
Reel Drive Assembly 4	Cooling Equipment Assembly 16
Drum Drive and Basket Assembly 5	Electric Equipment Assembly 17
Gearbox and Engine Assembly 6	Control Equipment Assembly 18
Gearbox Assembly 7	Carburetor Assembly 19
Differential Assembly No. 99-2038 9	Air Filter and Muffler Assembly 20
Handle Assembly 10	Fuel Tank and Valve Assembly 21
Cylinder and Crankcase Assembly 12	Starter Assembly 22
Piston and Crankshaft Assembly 13	Label Set 23
Valve and Camshaft Assembly 14	Attachments and Accessories List 24

Part Description Abbreviations

Part descriptions in this catalog may include the following abbreviations.

AR. as required	HYD. hydraulic
ASM. assembly	LH. left hand
BBC. blade brake clutch	NI. nylon insert
CARR. carriage	NPTF. national pipe thread fine
DEG. degrees	PFH. phillips flat head
EXT. external	PPH. phillips pan head
FH. flat head	PPHTF. phillips pan head thread forming
GA. gauge	PRH. phillips round head
HD. heavy-duty	PTH. phillips truss head
HF. hex flange	PTO. power-take-off
HH. hex head	RH. right hand
HHF. hex head flange	ROPS. roll-over protection system
HHFTF. hex head flange thread forming	SFH. slotted fillister head
HJ. hex jam	SHH. slotted hex head
HLH. hex lag head	SHWH. slotted hex washer head
HOC. height-of-cut	SPH. slotted pan head
HSBH. hex socket button head	SQH. square head
HSFH. hex socket flat head	SRH. slotted round head
HSH. hex socket head	STD. standard
HWH. hex washer head	TAP. self tapping
HWHTF. hex washer head thread forming	TTH. torx truss head

Footnotes

- ❶ Not serviced separately

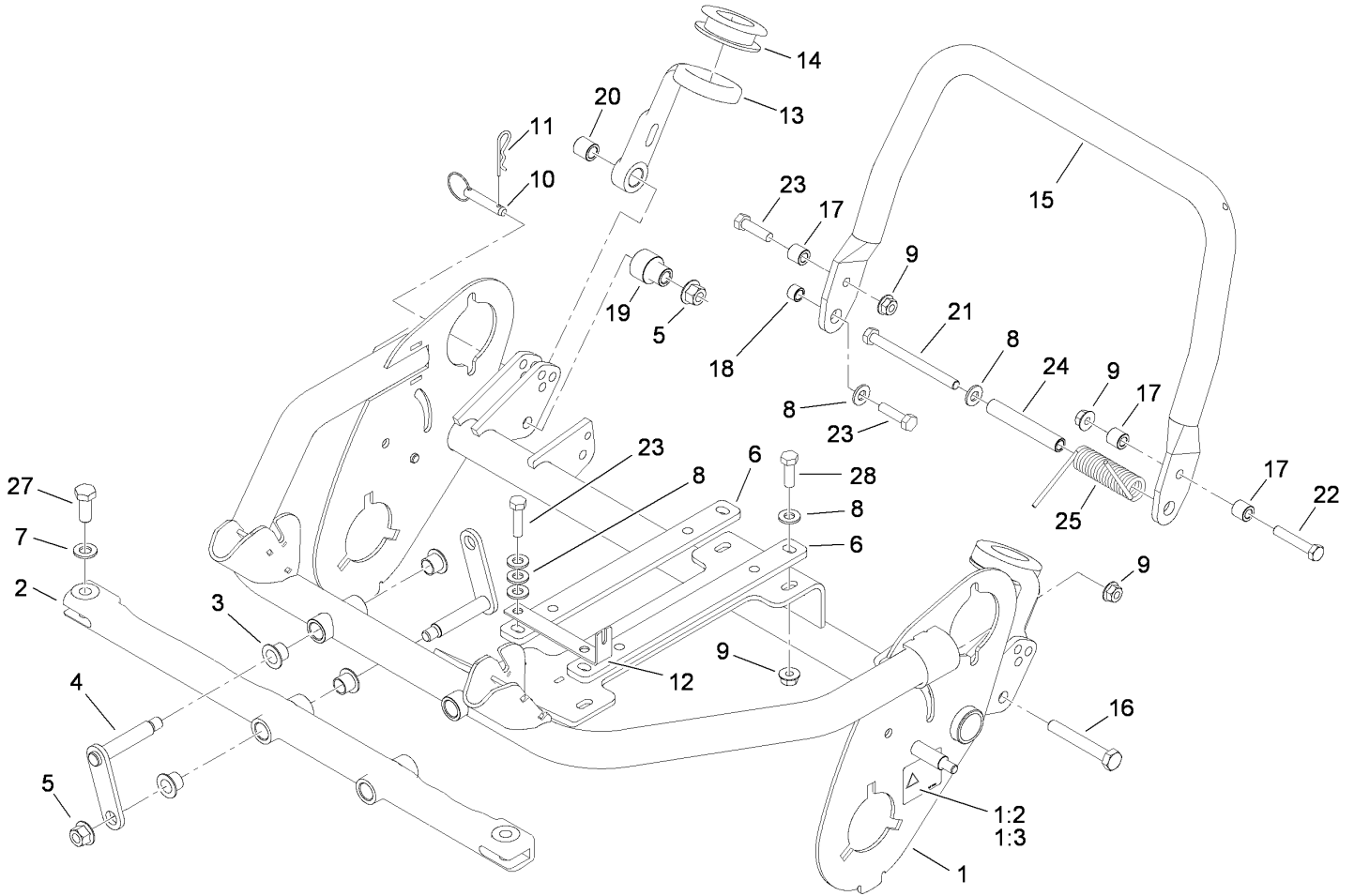

Frame Assembly

Ref	Part No.	Qty.	Description
1	110-2401	1	Frame ASM
1:2	93-9356	2	Decal-Warning, Belt
1:3	93-9389	2	Decal-Warning, Belt (Japan)
2	104-9798-01	1	Front Frame ASM
3	93-2561	8	Bushing-Flange
4	99-2063	4	Link ASM
5	104-2611	6	Nut-HF
6	99-2070-01	2	Base-Engine
7	33095-00	2	Washer-Flat
8	33094-00	8	Washer-Plain
9	104-2612	8	Nut-HF
10	93-6029	2	Pin-Clevis, Ring
11	3290-467	2	Pin-Hair
12	105-9939	1	Strap-Support, Cable
13	99-3774-03	2	Arm-Handle
14	65-7510	2	Grommet-Handle
15	99-3778-03	1	Kickstand
16	33115-070	2	Screw-HH
17	93-6024	3	Bushing-Support, Handle
18	65-7910	1	Spacer
19	108-3177	2	Spacer-Hub
20	99-2058	2	Spacer-Support, Handle
21	33114-100	1	Screw-HH
22	33114-045	1	Screw-HH

Ref	Part No.	Qty.	Description
23	33114-030	3	Screw-HH
24	104-0502	1	Spacer-Kickstand, Long
25	99-2011	1	Spring-Torsion
27	33115-025	2	Screw-HH
28	33114-025	3	Screw-HH

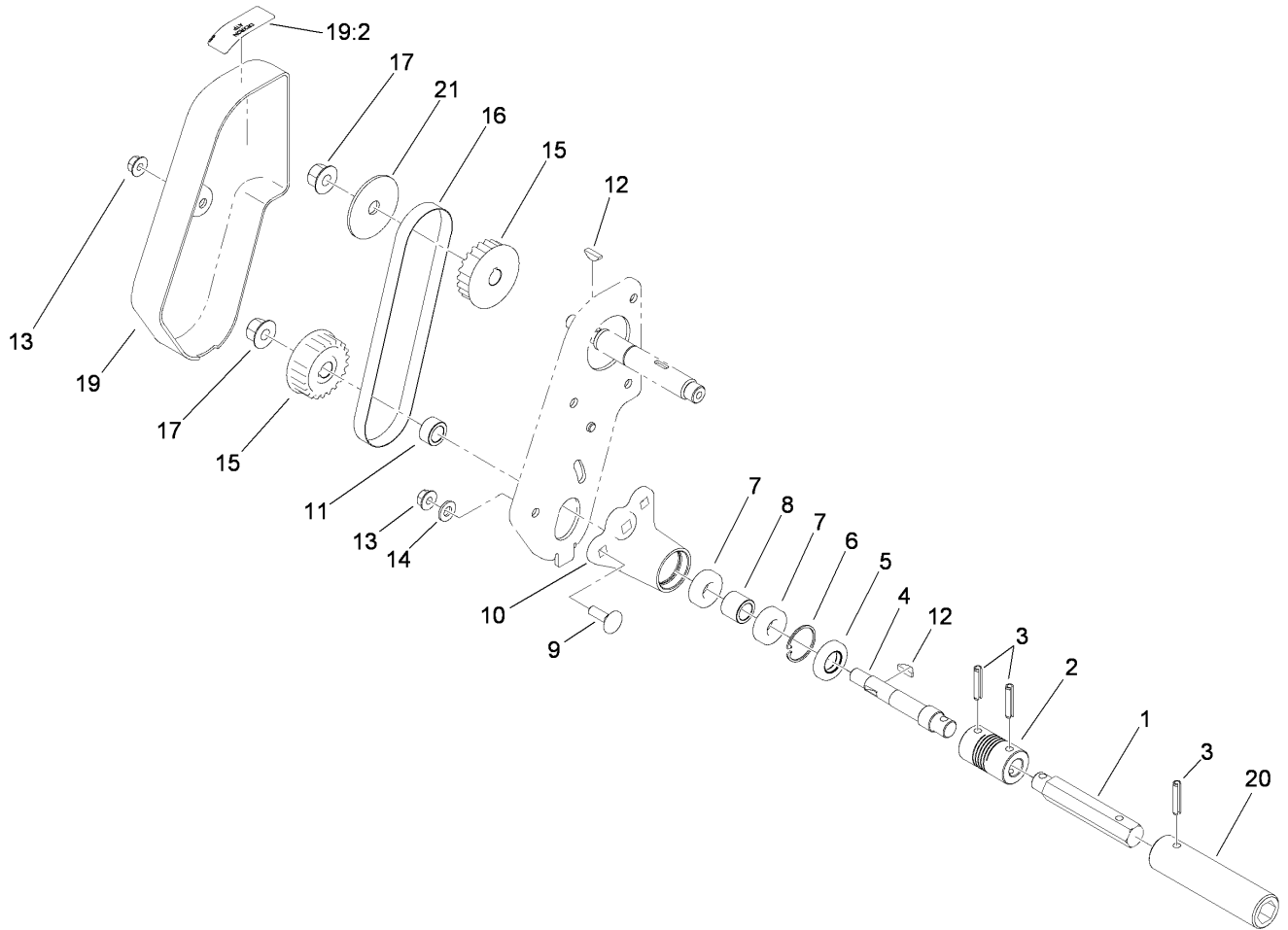

Reel Drive Assembly

Ref	Part No.	Qty.	Description
1	110-2389	1	Shaft-Hex
2	99-3757	1	Coupling-Flex
3	32121-69	3	Pin-Spring
4	110-2382	1	Shaft-Drive, Reel
5	107-3205	1	Seal-Oil
6	32151-51	1	Ring-Retaining
7	251-336	2	Bearing-Ball
8	99-2079	1	Spacer
9	33124-025	2	Screw-CARR
10	99-2083	1	Housing-Bearing
11	110-2381	1	Spacer
12	3257-30	2	Key-Woodruff
13	104-2612	3	Nut-HF
14	33094-00	2	Washer-Plain
15	107-9044	2	Pulley-22 Tooth
16	99-2022	1	Belt
17	115-1115	2	Nut-HHF, Lock
19	110-2286	1	Belt Cover ASM
19:2	105-2411	1	Decal-Oil, HYD
20	110-2390	1	Tube-Hex
21	104-0532	1	Washer-Pulley

--	--	--	--

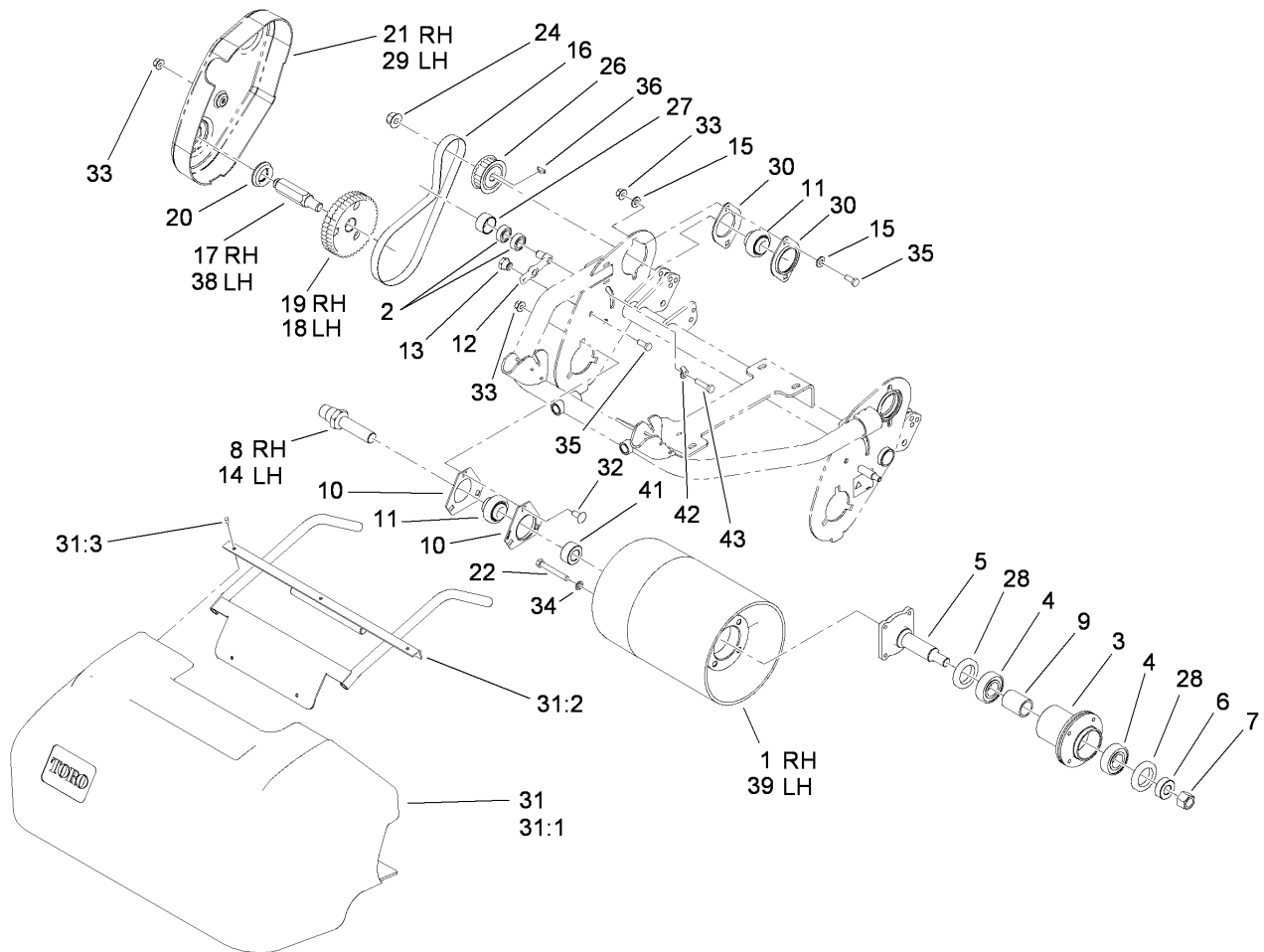

Drum Drive and Basket Assembly

Ref	Part No.	Qty.	Description
1	107-3210	1	Drum-Traction, RH
2	38-7820	4	Bearing-Ball
3	107-3214	1	Hub-Drum
4	251-82	2	Bearing-Ball
5	107-3215	1	Spindle-Drum
6	65-6530	1	Spacer
7	33028-00	1	Nut-Lock, NI
8	107-3206	1	Shaft-Drum, RH
9	65-6520	1	Spacer
10	108-8626	4	Flange-Triangular
11	106-8448	4	Bearing-Race, Extended
12	107-8179	2	Idler-Drive, Drum
13	105-5770	2	Nut-Shoulder
14	107-3207	1	Shaft-Drum, LH
15	33094-00	4	Washer-Plain
16	107-8175	2	Belt-Drum
17	107-3216	1	Shaft-Wheel, Transport (RH)
18	110-2290	1	Pulley-Driven, Traction (LH)
19	110-2289	1	Pulley-Driven, Traction (RH)
20	104-0533	2	Seal-Cover, Drum
21	105-5326	1	Cover-Drum, RH
22	33114-060	8	Screw-HH
24	115-1115	2	Nut-HHF, Lock
26	110-2315	2	Pulley-Driver, 22 Tooth

Ref	Part No.	Qty.	Description
27	104-2609	2	Sleeve-Pulley
28	253-159	2	Seal
29	105-5327	1	Cover-Drum, LH
30	700083	4	Flangette-Bearing
31	110-2380	1	Basket With Frame ASM
31:1	105-2439	1	Basket-Grass
31:2	112-9462-03	1	Basket Frame ASM
31:3	3269-28	5	Rivet-Pop
32	33124-020	10	Screw-CARR
33	104-2612	12	Nut-HF
34	3253-4	8	Washer-Lock
35	33114-020	2	Screw-HH
36	3257-30	2	Key-Woodruff
38	107-3224	1	Shaft-Wheel, Transport (LH)
39	107-3211	1	Drum-Traction, LH
41	106-8417	2	Spacer-Shaft, Drum
42	107-8180	2	Washer-Tab
43	33114-030	2	Screw-HH

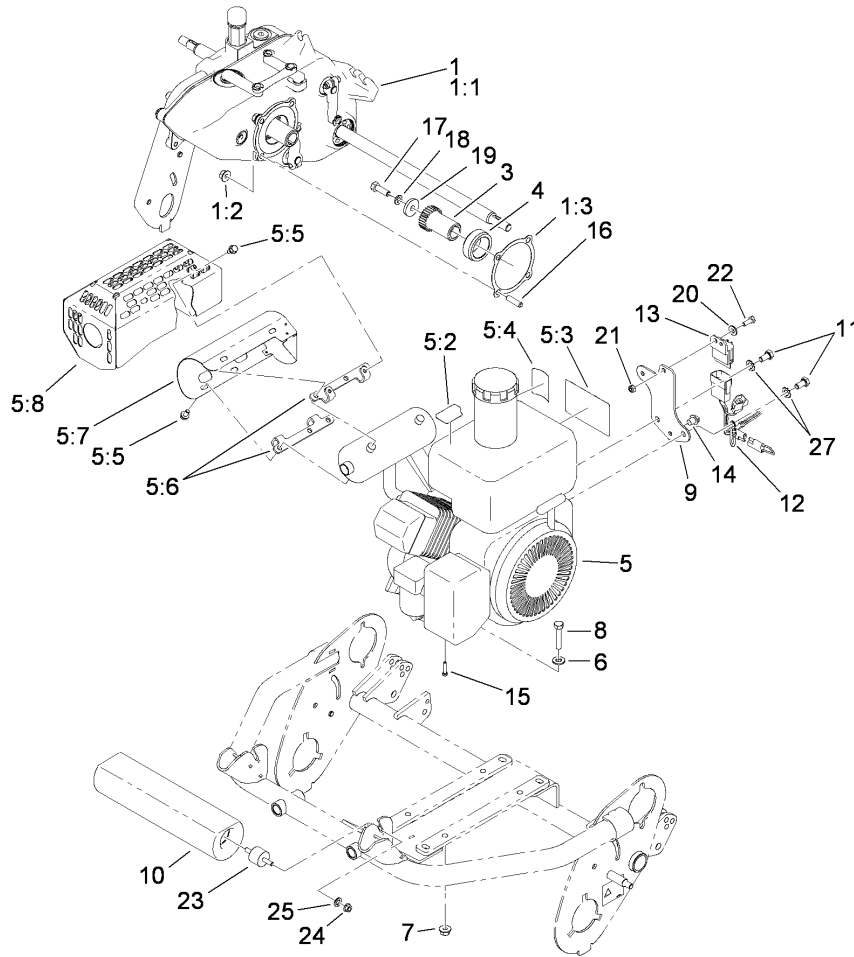

Gearbox and Engine Assembly

Ref	Part No.	Qty.	Description
1	117-1457	1	Gearbox Service ASM
1:1		1	Gearbox ASM
1:2	117-1350	4	Nut-HF, Lock
1:3	99-2052	1	Gasket-Flange
3	110-2445	1	Gear-Engine, 28 Tooth
4	99-2001	1	Adapter-Engine
5	115-1064	1	Engine ASM
5:2	115-1615	1	Decal-Surface, Hot
5:3	115-1613	1	Decal-Danger
5:4	93-9886	1	Decal-Fuel
5:5	104-2628	8	Screw-HWH
5:6	104-9771	2	Bracket-Guard, Muffler
5:7	110-7359	1	Muffler Shield ASM
5:8	110-7361-03	1	Guard-Muffler
6	33094-00	4	Washer-Plain
7	104-2612	8	Nut-HF
8	33114-040	4	Screw-HH
9	117-1365-03	1	Plate-Harness, Wire
10	107-8191-01	1	Damper-13Lbs
11	33114-016	2	Screw-HH
12	117-1410	1	Harness-Wire
13	1-323430	1	Module-Interlock
14	32180-030	1	Clip-Harness
15	94-9015	1	Screw-HH

Ref	Part No.	Qty.	Description
16	108-9446	4	Screw-Set
17	3210-5	1	Screw-HH
18	3253-4	1	Washer-Lock
19	65-8270	1	Washer
20	3256-22	1	Washer-Flat
21	33023-00	1	Nut-Lock
22	33113-016	1	Screw-HH
23	110-2259	2	Mount-Isolator
24	33003-00	2	Nut-HF
25	107-7601	2	Washer-Tab
27	3255-9	2	Washer-Lock

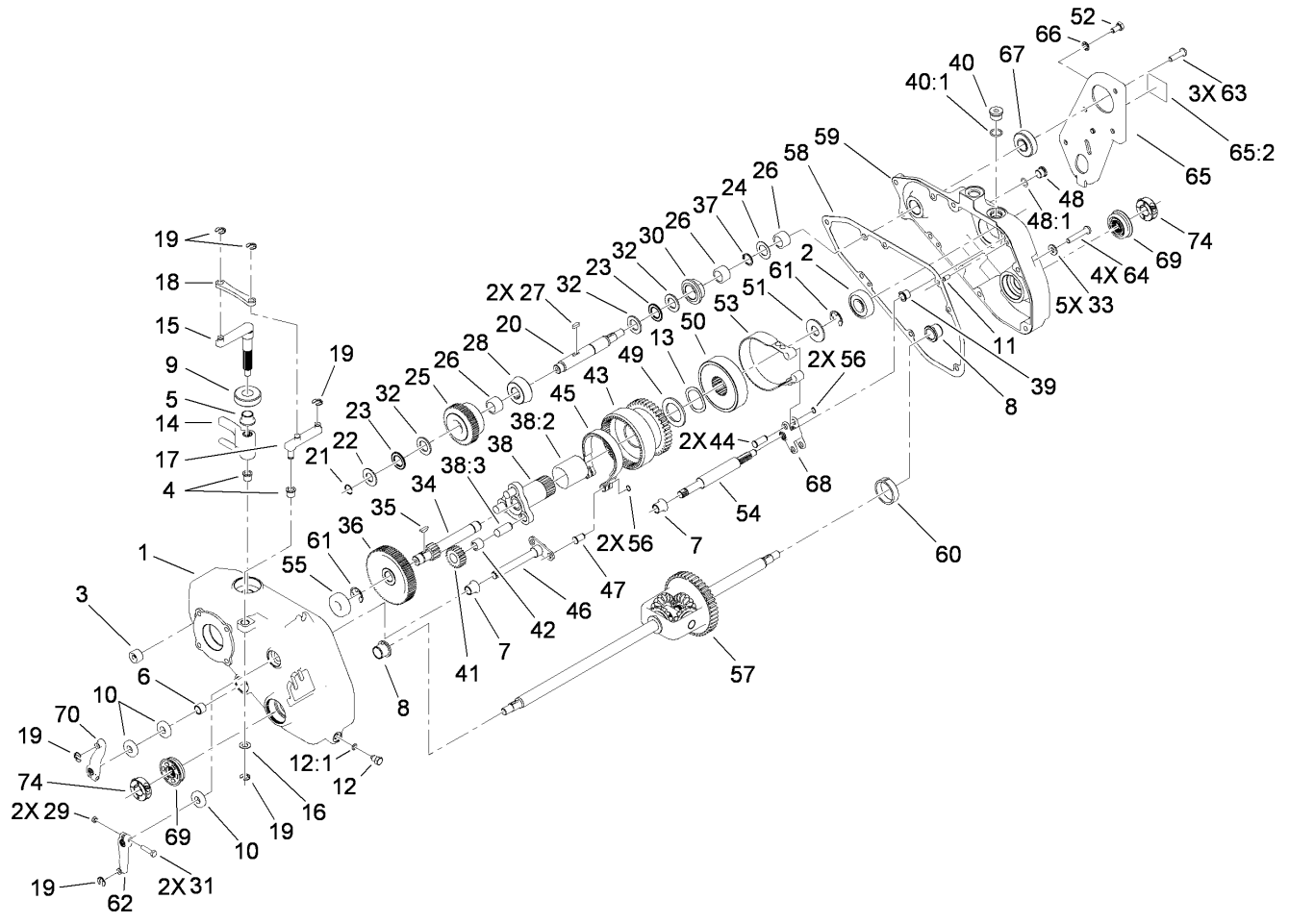

Gearbox Assembly

Ref	Part No.	Qty.	Description
1	117-1450	1	Housing-Gearbox
2	110-7339	1	Bearing-Ball
3	98-4194	1	Bearing-Needle, Caged
4	256-316	2	Bushing
5	256-287	1	Bushing
6	256-1	1	Bushing
7	256-219	2	Bushing
8	99-2062	2	Bushing-Keyed, Flanged
9	99-3842	1	Seal-Oil
10	99-2056	3	Seal-Oil
11	95-0715	2	Pin-Dowel
12	110-2455	1	Fitting-Plug, Magnetic
12:1	237-118	1	O-Ring
13	105-9944	1	Washer-Wave, Spring
14	99-2014	1	Fork-Clutch
15	99-2015	1	Shaft-Fork
16	37-8080	1	Washer-Thrust
17	110-2450	1	Lever-Bellcrank
18	99-3780	1	Link
19	32151-47	6	Ring-Retaining
20	115-1117	1	Shaft-Clutch, Reel
21	99-3805	1	Ring-Retaining
22	99-3806	1	Washer-Thrust
23	99-3836	2	Bearing-Thrust

Ref	Part No.	Qty.	Description
24	99-3837	1	Washer-Thrust
25	110-2444	1	Gear-Clutch, 55 Tooth (Reel Crowned)
26	1523	3	Bearing-Needle
27	99-2059	2	Key
28	107-3232	1	Cone ASM
29	33023-00	2	Nut-Lock
30	110-2459	1	Hub-Plunger
31	33113-025	2	Screw-HH
32	99-3807	3	Washer-Thrust
33	33094-00	5	Washer-Plain
34	107-8128	1	Shaft-Sun
35	3257-30	1	Key-Woodruff
36	110-2442	1	Gear-Traction, 78 Tooth (Crowned)
37	32120-72	1	Ring-Snap
38	110-2439	1	Carrier ASM
38:2	104-0524	1	Bushing-Carrier
38:3	107-9031	3	Pin-Dowel
39	104-9776	1	Bushing-Flanged
40	353-988	1	Plug-Hex
40:1	237-79	1	O-Ring
41	106-4694	3	Gear-Spur
42	48-2060	3	Bearing-Roller

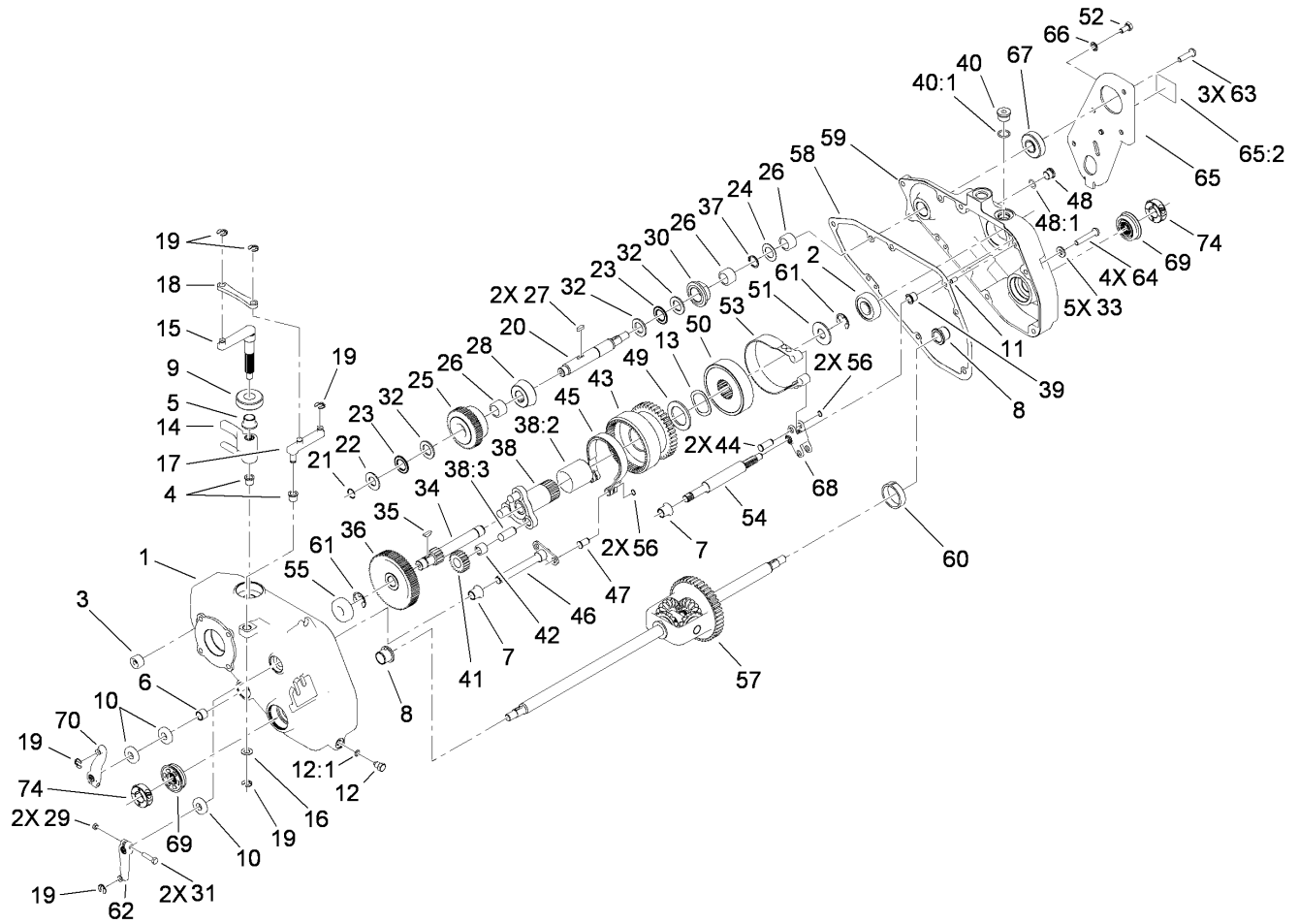

Gearbox Assembly (continued)

Ref	Part No.	Qty.	Description
43	110-2451	1	Gear-Ring, Planetary
44	106-8444	2	Pin-Clevis, Long
45	99-2049	1	Band-Brake
46	99-2020	1	Shaft-Brake
47	106-8445	2	Pin-Clevis, Short
48	353-989	1	Plug-Hex, Hollow
48:1	237-42	1	O-Ring
49	99-2054	1	Washer-Thrust
50	110-2452	1	Drum-Clutch, Traction
51	99-2055	1	Washer-Thrust
52	33114-016	1	Screw-HH
53	107-9042	1	Clutch Band ASM
54	105-9937	1	Shaft-Clutch, Traction
55	251-6	1	Bearing-Ball
56	32120-46	4	Ring-Retaining
57	99-2038	1	Differential ASM
58	117-1452	1	Gasket-Gearbox
59	117-1451	1	Cover-Gearbox
60	99-2061	1	Bushing-Keyed
61	32151-48	2	E-Ring
62	99-3761	1	Lever-Gearbox
63	99-6208	3	Screw-HSH
64	99-6207	4	Screw-HSBH
65	110-2293	1	Drive Plate ASM

Ref	Part No.	Qty.	Description
65:2	93-9389	1	Decal-Warning, Belt (Japan)
65:2	93-9356	1	Decal-Warning, Belt
66	3254-2	1	Washer-Lock, Internal
67	105-2429	1	Seal-Oil
68	105-9938	1	Hub-Clutch, Traction
69	117-1443	2	Seal-Oil
70	110-3451	1	Lever-Gearbox
74	117-1375	2	Collar ASM

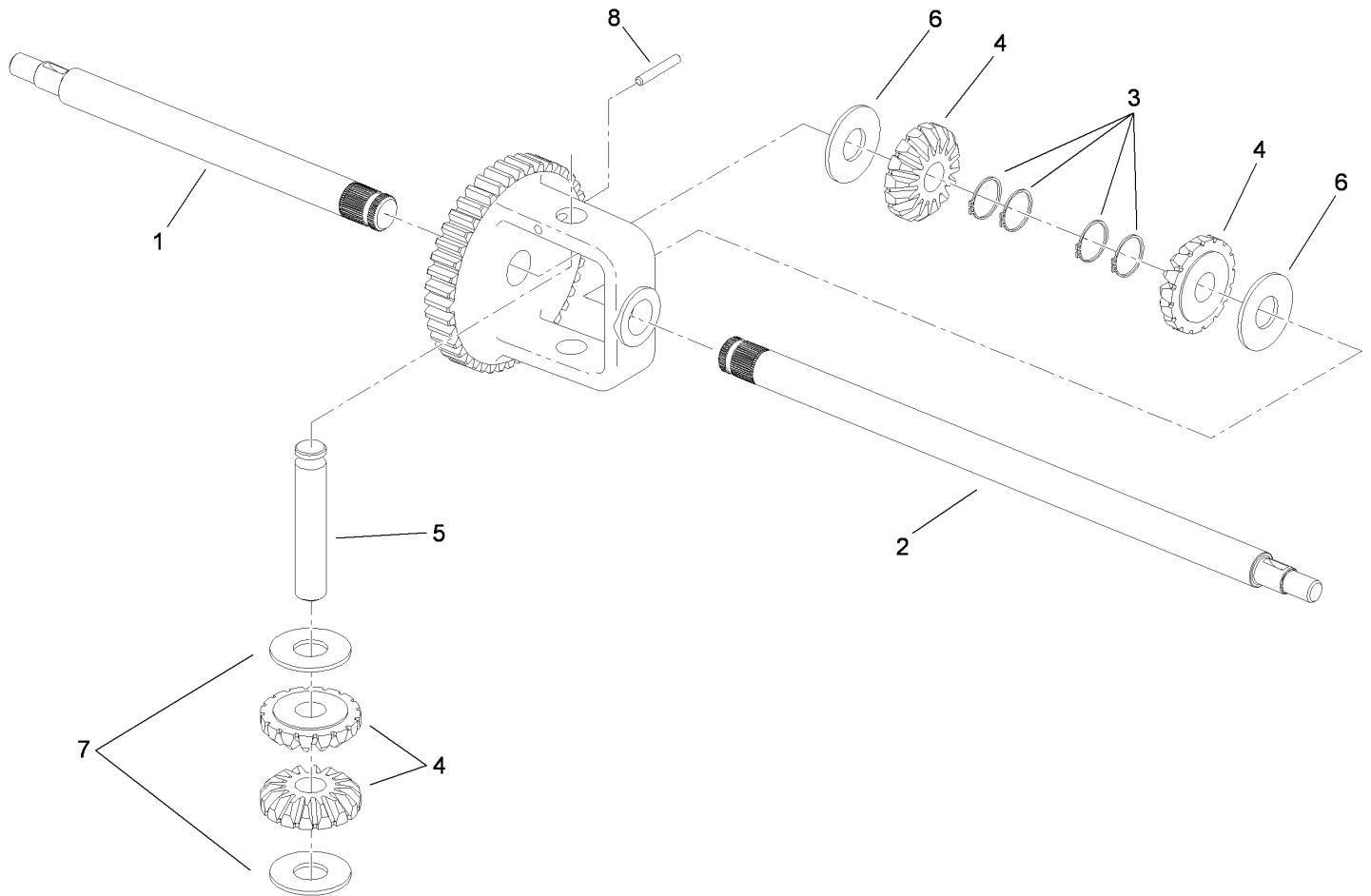

Differential Assembly No. 99-2038

Ref	Part No.	Qty.	Description
1	105-2402	1	Axle (Short)
2	105-2403	1	Axle (Long)
3	95-5746	2	Ring-Retaining
4	105-2405	1	Gear Set-Differential
5	105-2404	1	Pin-Drive
6	95-5745	2	Washer
7	105-2406	2	Washer-Thrust
8	32121-79	1	Pin-Roll

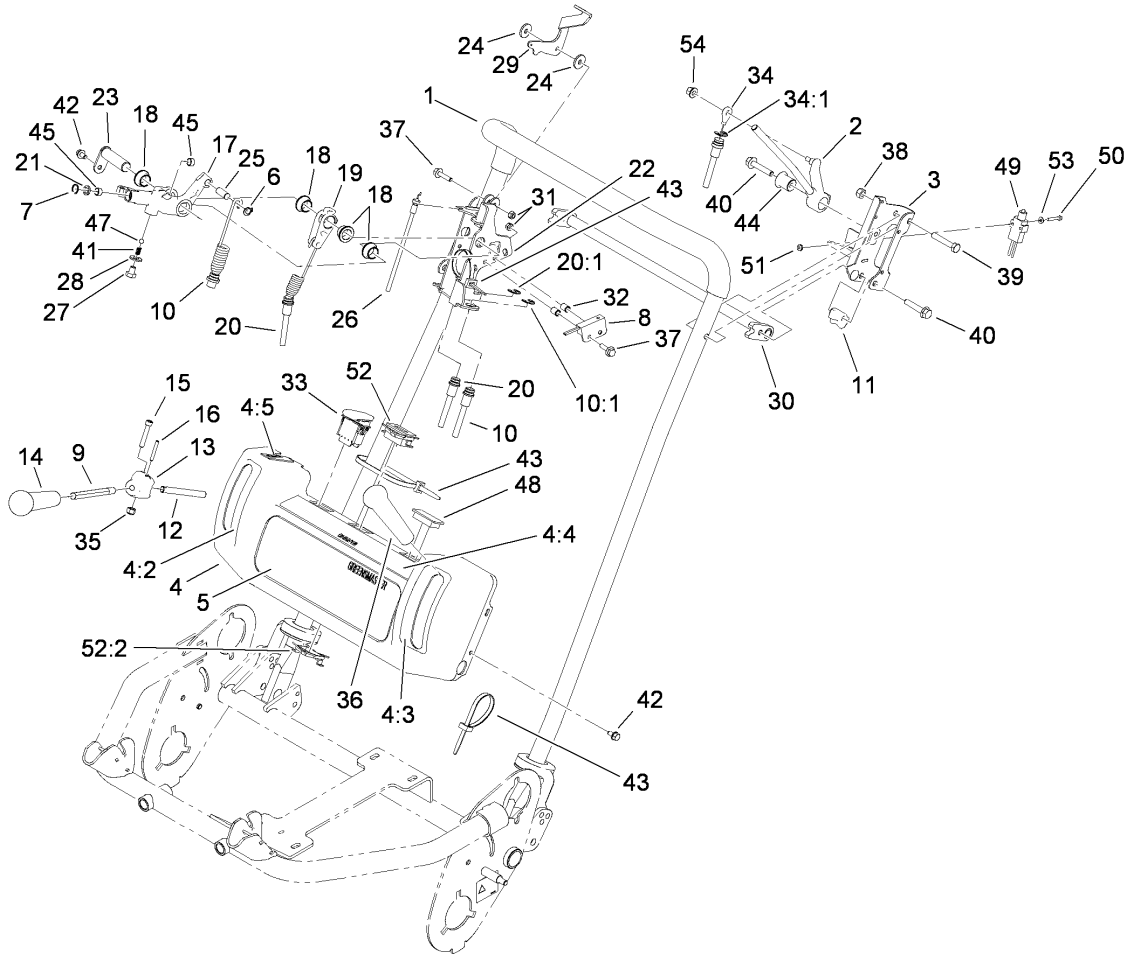

Handle Assembly

Ref	Part No.	Qty.	Description
1	110-2414	1	Handle
2	117-1361	1	Lever-Brake, Console
3	117-1363-03	1	Brake Bracket ASM
4	115-1123	1	Console ASM
4:2	104-2617	1	Decal-Lever, Traction
4:3	104-2618	1	Decal-Lever, Brake
4:4	115-1614	1	Decal-Warning
4:5	93-6085	1	Decal-Throttle
5	105-9916	1	Decal-Console, Main
6	105-2410	1	Ring-Retaining
7	105-5324	1	Ring-Retaining
8	100-1270	1	Switch-Proximity
9	105-5319	1	Rod-Handle
10	105-5328	1	Cable-Clutch, Traction
10:1	32120-47	1	Ring-Retaining, External
11	110-2415	2	Clamp-Handle
12	99-3835	1	Pin
13	104-9761	1	Hub-Mount, Handle
14	104-9760	1	Knob-Black
15	105-5349	1	Screw-HSH, Special
16	32121-51	1	Pin-Roll
17	104-9758	1	Lever-Control, Traction
18	80-1290	4	Bushing
19	99-3830	1	Lever-Reel

Ref	Part No.	Qty.	Description
20	99-3765	1	Cable-Clutch, Reel
20:1	32120-47	1	Ring-Retaining, External
21	105-2407	1	Wiper
22	110-7334-03	1	Control Bracket ASM
23	99-3833	1	Pin-Lever, Reel
24	66-2921	2	Washer-Friction
25	104-9782	1	Pin-Dowel
26	104-2620	1	Cable-Throttle
27	108-8646	1	Screw-HH, Lock
28	33094-00	1	Washer-Plain
29	108-3179	1	Lever-Throttle
30	112-9425	1	Handle-Crossmember
31	33023-00	3	Nut-Lock
32	105-2401	2	Spacer-Cable, Brake
33	112-9420	1	Switch-Engine
34	99-6214	1	Cable-Brake
34:1	32120-47	1	Ring-Retaining, External
35	3296-42	1	Nut-Lock, NI
36	104-9774	1	Knob-Red
37	33103-025	3	Screw-HHF
38	33024-00	2	Nut-Lock
39	33114-045	2	Screw-HH
40	112-9419	3	Screw-HHF, W/Lock
41	105-2443	1	Spring-Detent

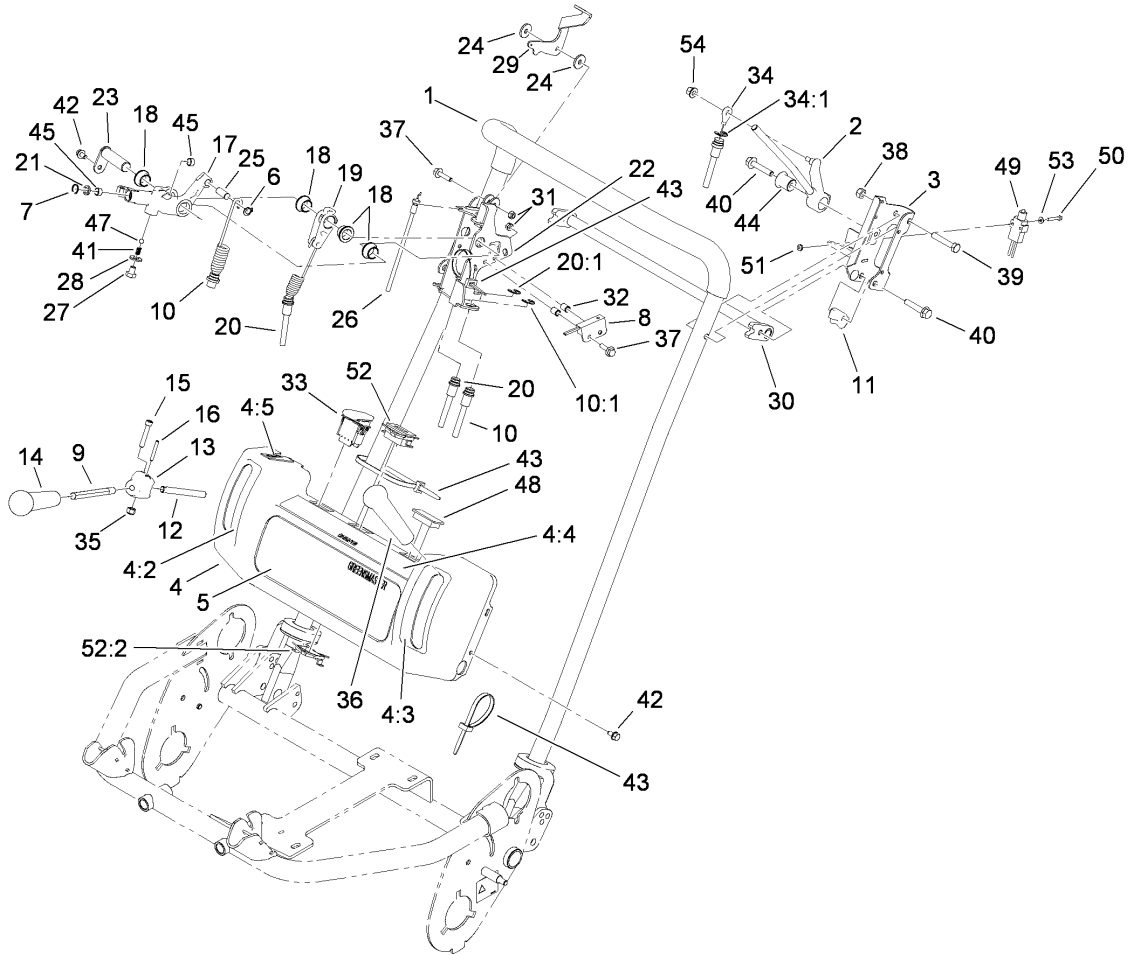

Handle Assembly (continued)

Ref	Part No.	Qty.	Description
42	104-2628	5	Screw-HWH
43	3290-378	5	Tie-Cable
44	112-9317	1	Bushing-Flanged
45	99-6247	2	Bushing-Bronze
47	105-2442	1	Ball-Detent
48	99-7420	1	Plug-Hole
49	95-8900	1	Switch
50	32105-9	2	Screw
51	3296-9	2	Nut-Lock
52	104-4233	1	Meter-Hour
52:2	104-4234	1	Clip-Mounting
53	3269-6	2	Washer-Flat
54	81-0130	1	Nut-Flange, NI

--	--	--	--

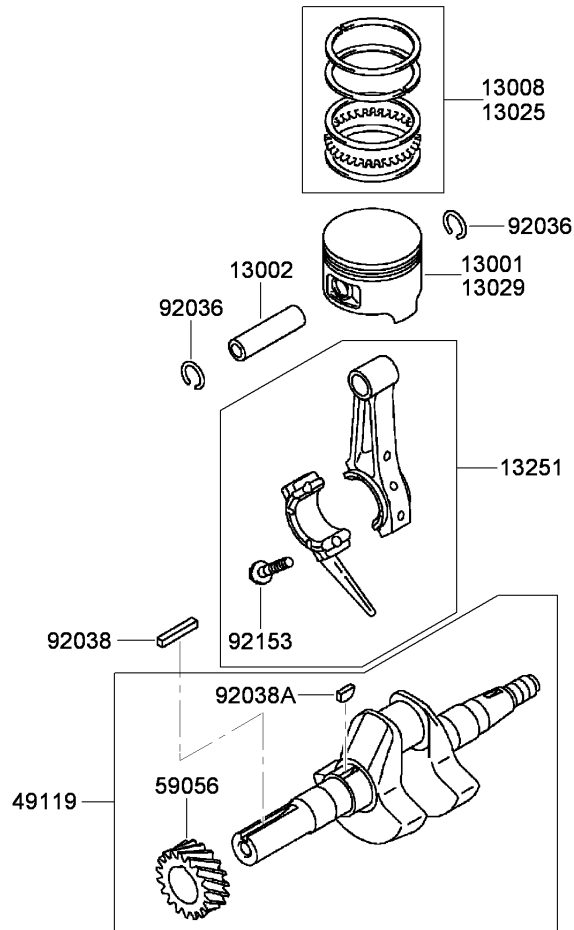

Piston and Crankshaft Assembly

Ref	Part No.	Qty.	Description				
13001	93-8502	1	Piston				
13002	93-8501	1	Pin-Piston				
13008	93-8503	1	Set-Ring, Piston				
13025	94-6837	1	Piston Ring Set (.05Mm)				
13029	94-6836	1	Piston (0.5 O S)				
13251	93-8528	1	Connecting Rod ASM				
49119	93-8696	1	Crankshaft ASM				
59056	94-9043	1	Gear-Helical				
92036	93-8500	2	Ring-Retaining				
92038	93-8526	1	Key				
92038A	93-8698	1	Key				
92153	115-1805	2	Bolt (6X30)				

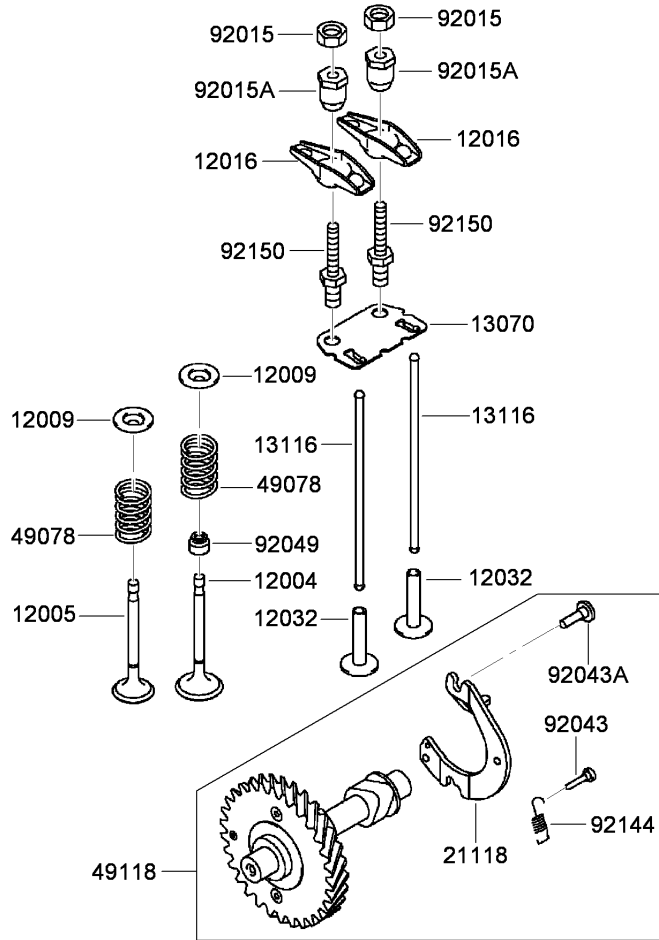

Valve and Camshaft Assembly

Ref	Part No.	Qty.	Description
12004	93-8532	1	Valve-Intake
12005	93-8529	1	Valve-Exhaust
12009	93-8531	2	Retainer-Spring, Valve
12016	93-8535	2	Arm-Rocker
12032	93-8539	2	Tappet
13070	115-1758	1	Guide
13116	93-8538	2	Rod-Push
21118	93-8543	1	Decompressor
49078	115-1763	2	Spring-Valve, Engine
49118	93-8699	1	Camshaft ASM
92015	93-8533	2	Nut
92015A	93-8534	2	Nut
92043	93-8542	1	Pin
92043A	93-8540	2	Pin
92049	115-1762	1	Seal-Oil
92144	93-8541	1	Spring
92150	93-8536	2	Bolt

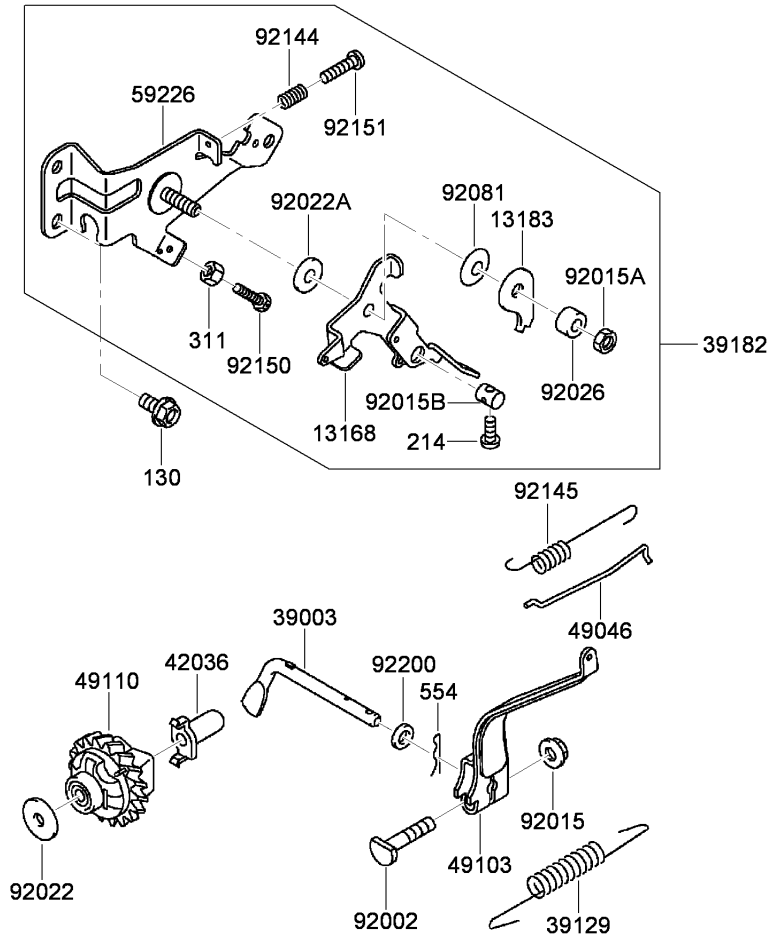

Control Equipment Assembly

Ref	Part No.	Qty.	Description
130	115-1809	2	Bolt-Flanged (6X12)
214	115-1778	1	Screw-Pan (4X14)
311	100-2668	1	Nut-Hex (4Mm)
554	93-8607	1	Pin-Snap (1.2X21.2)
13168	93-8598	1	Lever
13183	93-8592	1	Plate
39003	93-8609	1	Arm-Pivot
39129	94-9030	1	Spring-Governor
39182	115-1754	1	Control Panel ASM
42036	108-2567	1	Sleeve
49046	115-1811	1	Rod-Governor
49103	93-8603	1	Arm-Governor
49110	115-1812	1	Governor ASM
59226	115-1773	1	Panel-Control
92002	93-8606	1	Bolt (6X28)
92015	93-8631	1	Nut
92015A	93-8595	1	Nut
92015B	93-8597	1	Nut
92022	94-6842	1	Washer (6.2X20X0.5)
92022A	93-8590	1	Washer
92026	115-1776	1	Spacer
92081	115-1775	1	Spring
92144	93-8588	1	Spring
92145	115-1810	1	Spring

Ref	Part No.	Qty.	Description
92150	115-1813	1	Bolt
92151	115-1774	1	Bolt (4X22)
92200	93-8608	1	Washer (6.5X11.5X2.0)

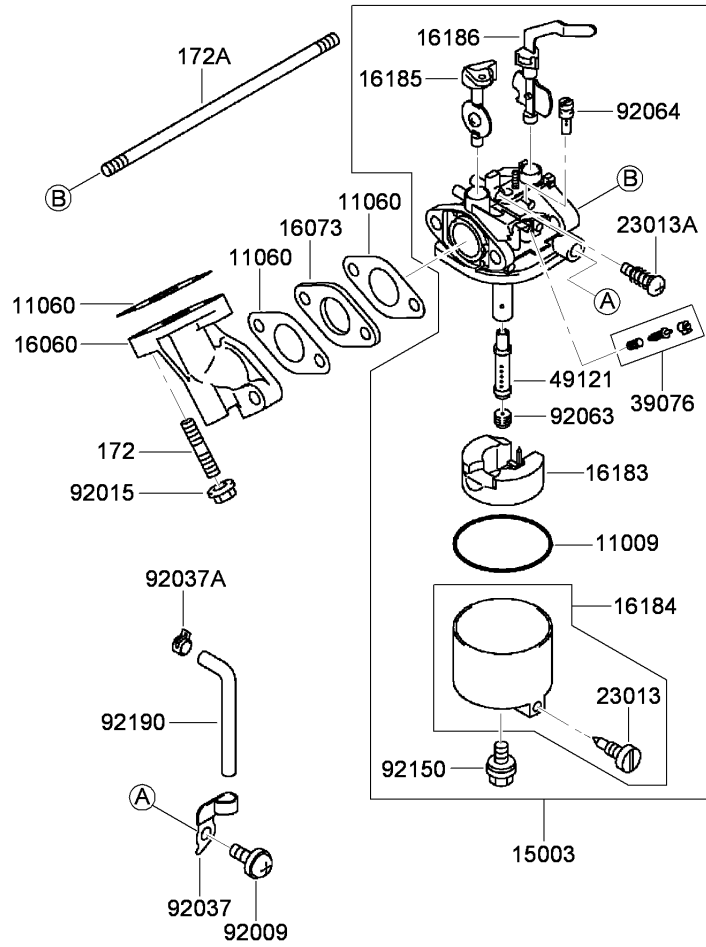

Carburetor Assembly

Ref	Part No.	Qty.	Description
172	93-8632	2	Bolt-Stud (6X18)
172A	115-1814	1	Bolt-Stud (6X73)
11009	93-8624	1	Gasket
11060	93-8613	3	Gasket
15003	94-9032	1	Carburetor ASM
16060	93-8633	1	Pipe-Intake
16073	94-9048	1	Insulator
16183	94-6844	1	Float ASM
16184	93-8625	1	Float Chamber ASM
16185	94-9033	1	Throttle Valve ASM
16186	93-8617	1	Choke Valve ASM
23013	93-8626	1	Screw ASM
23013A	93-8619	1	Screw ASM
39076	94-9034	1	Limiter
49121	94-9035	1	Nozzle-Main
92009	94-6845	1	Screw
92015	93-8631	2	Nut
92037	94-6846	1	Clamp
92037A	93-8629	1	Clamp
92063	94-9036	1	Jet-Main (No.65)
92064	94-9037	1	Jet-Pilot (No.40)
92150	93-8627	1	Bolt
92190	93-8630	1	Tube

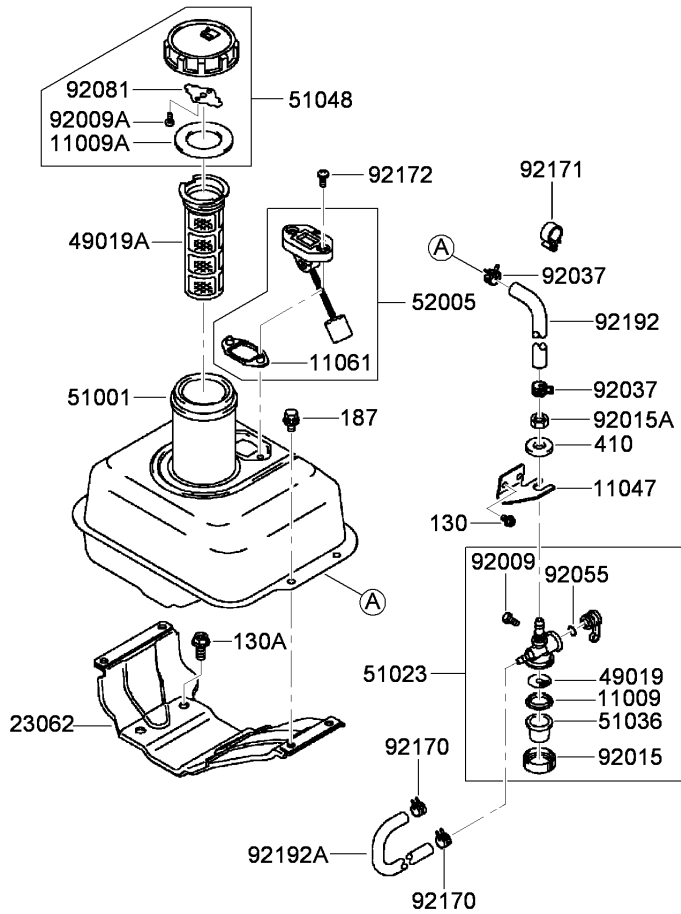

Fuel Tank and Valve Assembly

Ref	Part No.	Qty.	Description
130	115-1864	2	Bolt-Flanged (5X8)
130A	115-1867	4	Bolt-Flanged (8X18)
187	115-1760	4	Bolt-Upset, Wsp (6X16)
410	93-8668	1	Washer-Plain (10Mm)
11009	93-8673	1	Gasket
11009A	93-8662	1	Gasket
11047	93-8681	1	Bracket
11061	104-2384	1	Gasket-Gauge, Fuel
23062	104-2383	1	Bracket-Tank
49019	94-6849	1	Filter-Tapper, Fuel
49019A	94-6826	1	Filter-Fuel
51001	104-2382	1	Tank-Fuel
51023	93-8669	1	Fuel Tapper ASM
51036	93-8674	1	Cup-Tapper, Fuel
51048	93-8660	1	Fuel Cap ASM
52005	93-8685	1	Gauge-Fuel
92009	93-8670	1	Screw
92009A	93-8661	2	Screw
92015	93-8675	1	Nut
92015A	94-9042	1	Nut
92037	115-1861	2	Clamp-Clip, Hose
92055	93-8671	1	O-Ring
92081	93-8663	1	Spring
92170	115-1865	2	Clamp

Ref	Part No.	Qty.	Description
92171	115-1862	1	Clamp
92172	115-1860	2	Screw (5X12)
92192	115-1863	1	Tube (6.2X13.2X200)
92192A	115-1866	1	Tube (4X11X160)

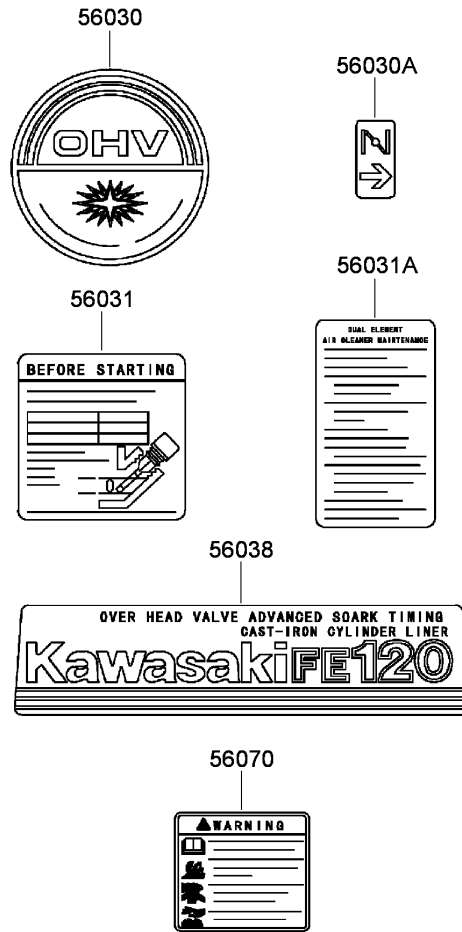

Label Set

Ref	Part No.	Qty.	Description
56030	94-9027	1	Label-Recoil
56030A	93-8687	1	Decal-Choke
56031	93-8689	1	Decal-Instructions
56031A	93-8690	1	Decal-Maintenance
56038	94-9028	1	Label-Kawasaki
56070	93-8692	1	Decal-Warning

Attachments and Accessories

For 04022 - Greensmaster Flex 21 Mower

Product Name	Model/Part
Light Kit	04061
Out Front Brush Kit	04119
Wheel Kit	04123
11-Blade Cutting Unit	04202
Operator Presence Kit	112-9282

NOTES

NOTES

NOTES

