



TimeCutter™ Z4220 Riding Mower

Model No. 74363 - 290000001 and up.

Parts Catalog

Ordering Replacement Parts

To order replacement parts, please supply the part number, the quantity, and the description of each part desired.

Understanding Reference Numbers

Each identified part in an illustration has a reference number. The reference number for a part also appears in the parts list, along with other information about the part.

This catalog uses two special reference number formats, one to indicate parts in a service assembly and another to indicate the quantity of a given part in an illustration.

Service Assembly Reference Numbers

Parts in service assemblies have reference numbers in the form a:b. The a represents the reference number of the entire service assembly and the b represents a sequential number unique to each part within the service assembly.

For example, a wheel assembly might be identified by reference number 6, the tire by 6:1, the valve by 6:2, and the wheel by 6:3. When you order the assembly identified by reference number 6, you receive all parts identified by reference numbers 6:1, 6:2, and 6:3. However, you may also order any part individually. Reference numbers of this type appear in illustrations and in part lists.

Reference Numbers Indicating Quantity

In an illustration, if a reference number indicates more than one part, the reference number has the form nX y. The n represents the quantity of the part, the X is the multiplication symbol, and the y represents the reference number.

For example, in an illustration, the reference number 2X 37 means that two of the parts identified by reference number 37 are indicated.

Contents

Description	Page	Description	Page
Frame Assembly 3	Engine, Muffler and Clutch Assembly 12
Deck Lift and Seat Support Assembly 4	Styling and Fuel System Assembly 13
Seat Assembly 5	42 Inch Deck Assembly 14
Control Assembly 6	42 Inch Deck Assembly No. 117-1290 15
Hydro Drive Assembly 7	42 Inch Deck Spindle and Belt Drive Assembly 16
RH Hydro Assembly No. 110-6771 8	Electrical Assembly 17
LH Hydro Assembly No. 110-6770 10	Attachments and Accessories List 18

Part Description Abbreviations

Part descriptions in this catalog may include the following abbreviations.

AR. as required	HWHTF. hex washer head thread forming
ASM. assembly	HYD. hydraulic
BBC. blade brake clutch	LH. left hand
CARR. carriage	NI. nylon insert
CCW. counter clock wise	NPTF. national pipe thread fine
CW. clockwise	PFH. phillips flat head
DEG. degrees	PPH. phillips pan head
ECM. electronic control module	PPHTF. phillips pan head thread forming
EXT. external	PRH. phillips round head
FH. flat head	PTH. phillips truss head
GA. gauge	PTO. power-take-off
HD. heavy-duty	RH. right hand
HF. hex flange	ROPS. roll-over protection system
HH. hex head	SFH. slotted fillister head
HHF. hex head flange	SHH. slotted hex head
HHFTF. hex head flange thread forming	SHWH. slotted hex washer head
HJ. hex jam	SPH. slotted pan head
HLH. hex lag head	SQH. square head
HOC. height-of-cut	SRH. slotted round head
HSBH. hex socket button head	STD. standard
HSFH. hex socket flat head	TAP. self tapping
HSH. hex socket head	TTH. torx truss head
HWH. hex washer head	

Footnotes

- | | |
|---|---|
| <ul style="list-style-type: none"> ❶ Not illustrated ❸ Optional Equipment | <ul style="list-style-type: none"> ❷ Not serviced separately ❹ Obtain parts from www.kohlerplus.com |
|---|---|

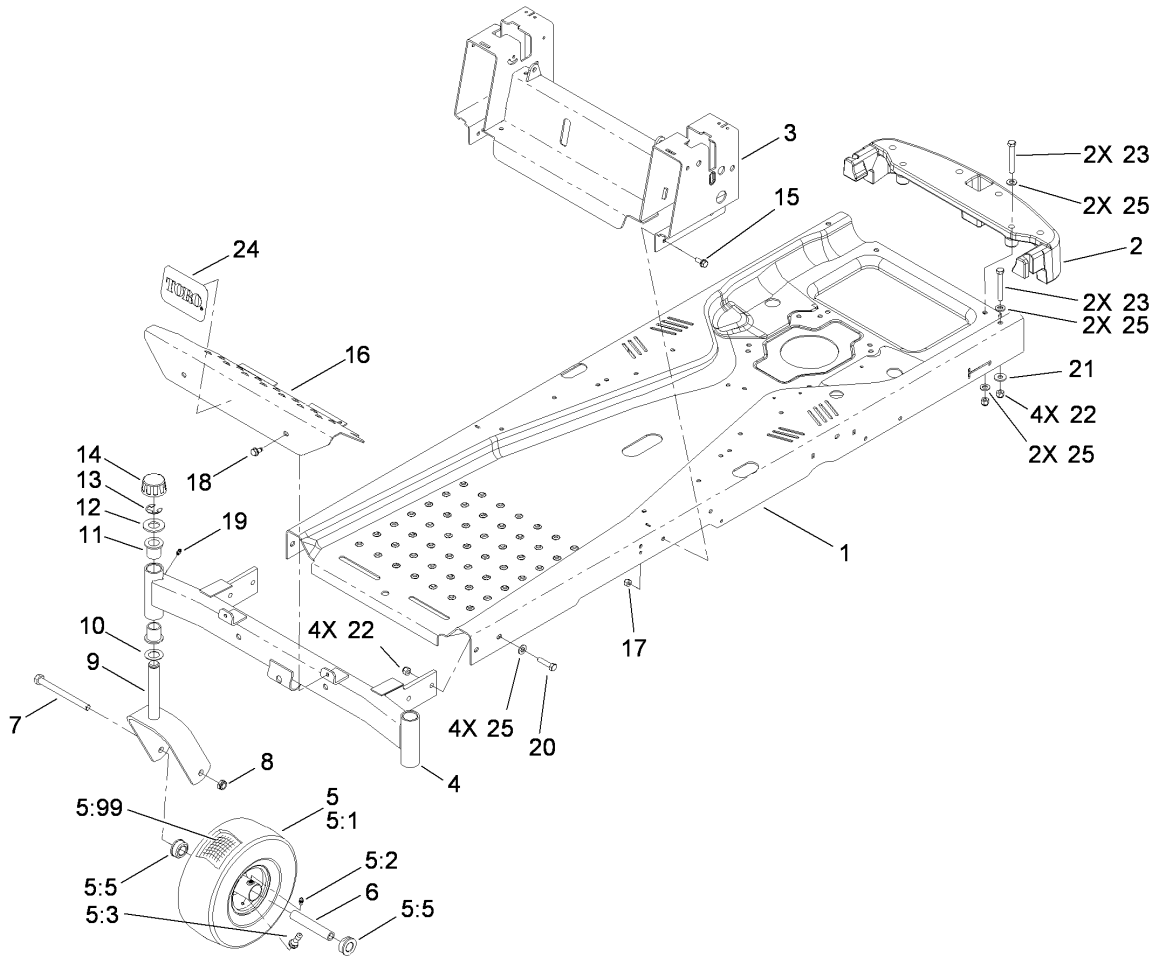

Frame Assembly

Ref	Part No.	Qty.	Description
1	115-2464-01	1	Frame
2	110-6899-03	1	Bumper-Rear
3	115-5041-03	1	Seat Pivot/Control ASM
4	108-7882-01	1	Front Axle ASM
5	105-3471	2	Front Wheel And Tire ASM
5:1	105-1943	1	Tire
5:2	302-5	1	Fitting-Grease
5:3	232-27	1	Stem-Valve
5:5	114-1640	2	Bushing-Flange
5:99	93-4244	1	Tube-Inner (W/Valve)
6	104-3667	2	Spanner-Wheel
7	325-22	2	Screw-HH
8	3296-45	2	Nut-Lock, NI
9	108-7851-01	2	Caster Fork ASM
10	110-6767	2	Washer-Thrust
11	1-303514	4	Bearing-Flanged
12	104-8076	2	Washer
13	32151-103	2	Ring-Retaining, EXT
14	61-9780	2	Cap-Hub
15	3234-47	7	Screw-HHF
16	108-7855-03	1	Footrest
17	3296-29	7	Nut-Lock, NI
18	32104-32	2	Screw-HWH
19	302-5	2	Fitting-Grease

Ref	Part No.	Qty.	Description
20	323-8	4	Screw-HH
21	80-6990	2	Washer-Hardened
22	3296-39	8	Nut-Lock, NI
23	323-13	4	Screw-HH
24	99-2385	1	Decal
25	3256-24	10	Washer-Flat

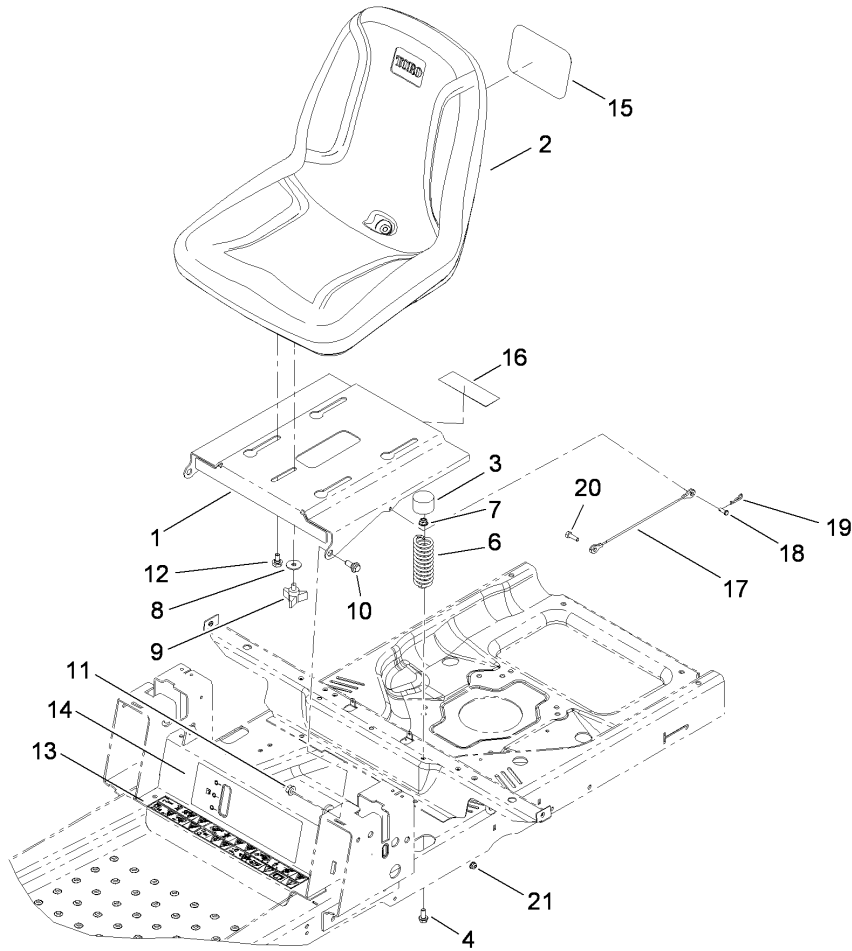

Seat Assembly

Ref	Part No.	Qty.	Description
1	115-2465-03	1	Base-Seat
2	117-1226	1	Seat-18 Inch
3	701178	2	Cap-Protector
4	3234-47	2	Screw-HHF
6	92-7054	2	Spring-Compression
7	104-8300	2	Nut-Flange, NI
8	5-4460	1	Washer-Pivot
9	92-9674	1	Knob
10	94-7582	2	Bolt-Shoulder
11	32128-21	2	Nut-HF
12	37-8771	4	Bolt-Shoulder
13	115-2469	1	Decal-Danger
14	115-2489	1	Decal-Timecutter
15	99-4693	1	Decal
16	106-8717	1	Decal-Service
17	109-2628	1	Cable-Stop, Seat
18	60-1730	1	Pin-Clevis
19	1-806003	1	Pin-Cotter, Hair
20	321-5	1	Screw-HH
21	104-7201	1	Nut-HF

--	--	--	--

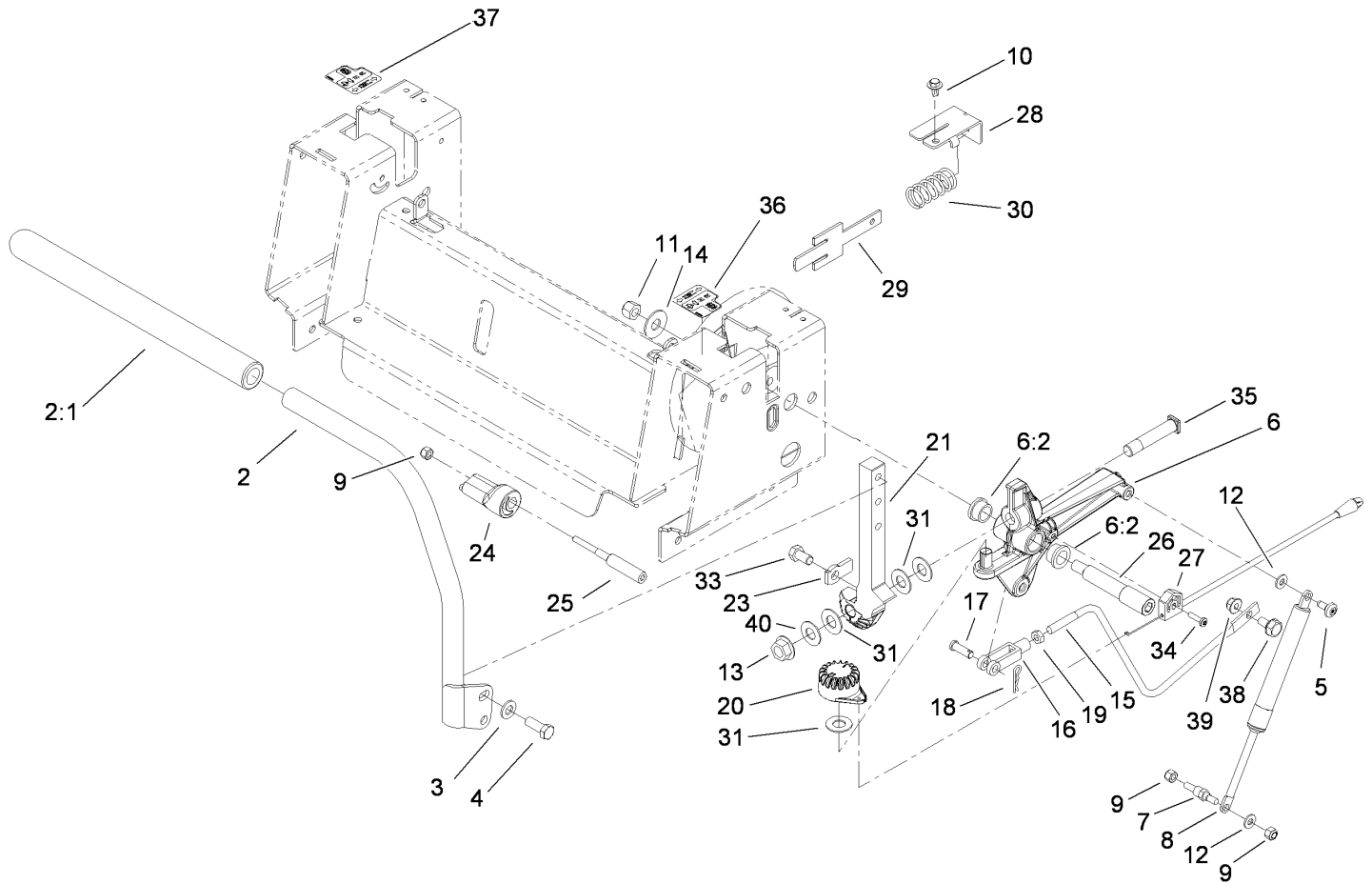

Control Assembly

Ref	Part No.	Qty.	Description
1	110-6814	1	RH Handle ASM
1:1	108-6187	1	Grip
2	110-6815	1	LH Handle ASM
2:1	108-6187	1	Grip
3	3256-24	4	Washer-Flat
4	323-6	4	Screw-HH
5	112-4004	2	Screw-Shoulder
6	110-6828	2	Activator Arm ASM
6:2	105-3455	2	Bushing
7	110-6810	2	Stud-Damper
8	103-2913	2	Damper-Control, Motion
9	3296-42	6	Nut-Lock, NI
10	46-8560	2	Screw-HHF
11	3296-48	2	Nut-Lock, NI
12	3256-22	4	Washer-Flat
13	32128-23	2	Nut-HF
14	3256-5	2	Washer-Flat
15	110-6693	2	Link-Hydro
16	1-303105	2	Yoke-Adjustable
17	1-808280	2	Pin-Clevis
18	1-806003	2	Pin-Cotter, Hair
19	3220-2	2	Nut-Jam
20	110-6845	2	Gear-Control
21	110-6783-03	1	Arm-Actuator, LH

Ref	Part No.	Qty.	Description
22	110-6782-03	1	Arm-Actuator, RH
23	115-5023	2	Tab-Stop
24	110-6873	2	Eccentric
25	110-6874	2	Screw-Eccentric
26	110-6875	2	Bolt-Shoulder
27	110-6858	2	Cable-Brake, Parking
28	110-6751	2	Bracket-Return
29	110-6750	2	Plate-Return
30	110-6752	2	Spring
31	110-6894	8	Washer-Pivot
33	323-4	2	Screw-HH
34	110-0863	2	Screw-Torx
35	110-6784	2	Bolt-Shoulder
36	112-9750	1	Decal-Control Lever, LH
37	112-9751	1	Decal-Control Lever, RH
38	37-8771	2	Bolt-Shoulder
39	104-8300	2	Nut-Flange, NI
40	112-9771	2	Washer-Teflon

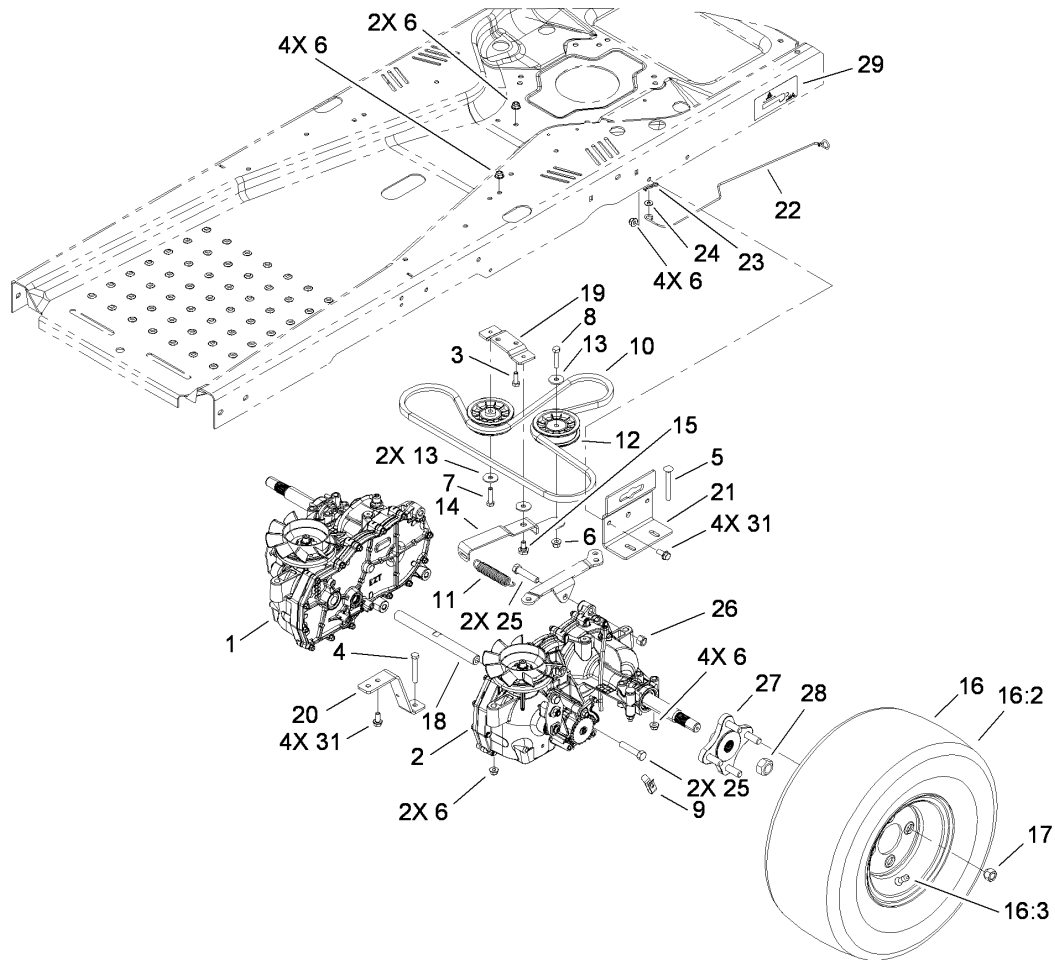

Hydro Drive Assembly

Ref	Part No.	Qty.	Description
1	110-6771	1	Hydro-RH
2	110-6770	1	Hydro-LH
3	322-4	2	Screw-HH
4	322-11	2	Screw-HH
5	3230-9	4	Screw-CARR
6	104-8300	17	Nut-Flange, NI
7	322-6	1	Screw-HH
8	322-7	1	Screw-HH
9	110-6677	2	Clip-Spring
10	110-6774	1	V-Belt
11	63-1590	1	Spring-Idler
12	110-6775	2	Pulley-Idler
13	5-4460	3	Washer-Pivot
14	110-1925	1	Arm-Idler
15	37-8771	1	Bolt-Shoulder
16	110-6881	2	Wheel And Tire ASM
16:2	110-6885	1	Tire
16:3	232-27	1	Stem-Valve
●16:99	107-2491	1	Tube-Tire
17	242-50	8	Nut-Lug
18	110-6807	1	Shaft-Cross
19	110-1926	1	Plate-Pivot
20	110-6806-03	2	Strap-Torque
21	110-6878-03	2	Support-Hydro

Ref	Part No.	Qty.	Description
22	110-6787	2	Rod-Bypass
23	1-806003	2	Pin-Cotter, Hair
24	3256-22	2	Washer-Flat
25	324-8	4	Screw-HH
26	3296-48	2	Nut-Lock, NI
27	112-3979	2	Hub ASM
28	112-3982	2	Nut-Lock
29	114-8532	1	Decal-Transport, LH
●30	114-8531	1	Decal-Transport, RH
31	3234-47	8	Screw-HHF

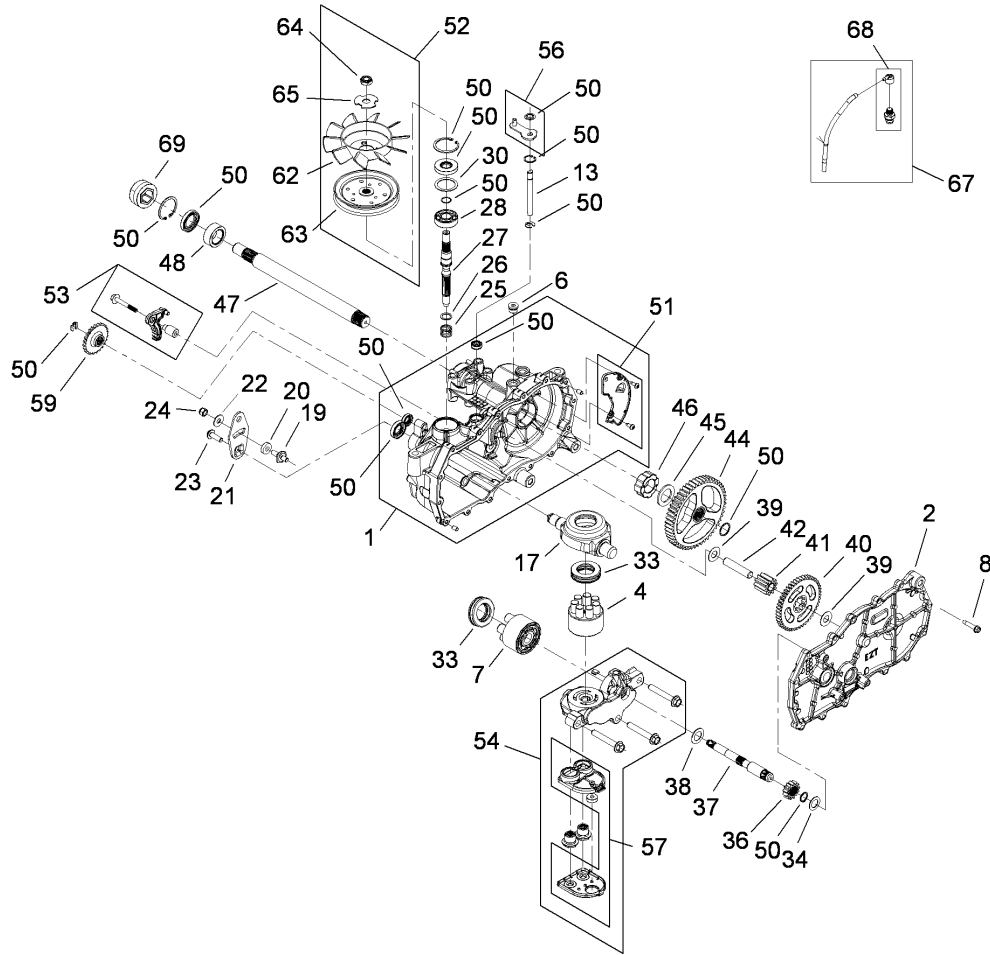

RH Hydro Assembly No. 110-6771

Ref	Part No.	Qty.	Description
1	114-1630	1	RH Main Housing ASM
2	114-1631	1	RH Side ASM
4	110-8561	1	Pump Block ASM
6	104-2189	1	Plug-Thread, Straight
7	103-2666	1	Cylinder Block Kit
8	104-5305	16	Screw-HHF
13	106-8678	1	Rod-Bypass
17	104-5304	1	Swashplate-Trunnion
19	104-2116	1	Stud
20	112-9853	1	Puck-Friction
21	106-8747	1	Arm-Control
22	5-4460	1	Washer-Pivot
23	107-2488	1	Screw
24	105-1872	1	Nut
25	94-1936	1	Spring-Block
26	94-1937	1	Washer-Thrust, Block
27	104-5306	1	Shaft-Input
28	104-5311	1	Bearing-Ball
30	104-5308	1	Spacer
33	94-6922	2	Bearing-Thrust
34	104-5339	1	Washer-Flat
36	104-5316	1	Gear-Pinnion, 13T
37	114-1632	1	Shaft-Motor
38	104-5360	1	Washer-Shaft, Motor

Ref	Part No.	Qty.	Description
39	94-1933	2	Washer
40	104-5317	1	Gear
41	104-5318	1	Gear-Jackshaft, 10T
42	104-5329	1	Pin-Jackshaft
44	112-9855	1	Gear-52T, Bull
45	112-9856	1	Washer
46	112-9857	1	Bearing-Sleeve
47	112-9858	1	Shaft-Axle
48	112-9859	1	Bushing-Axle
50	106-8686	1	Seal Kit
51	106-8697	1	RH Expansion Plate Kit
52	106-8698	1	Fan Pulley Kit
53	114-1633	1	Brake Arm Kit
54	112-9861	1	RH Center Section Filter Kit
55	104-2147	1	Sealant
56	107-2489	1	Bypass Arm Kit
57	114-1634	1	Filter Kit
59	106-8694	1	Disc-Brake, Cog
62	110-8566	1	Fan-6 Inch, 10 Blade
63	104-1754	1	Pulley
64	105-1875	1	Nut-Lock
65	107-9122	1	Washer-Slotted
67	112-9866	1	Breather Kit
68	114-1635	1	Breather ASM

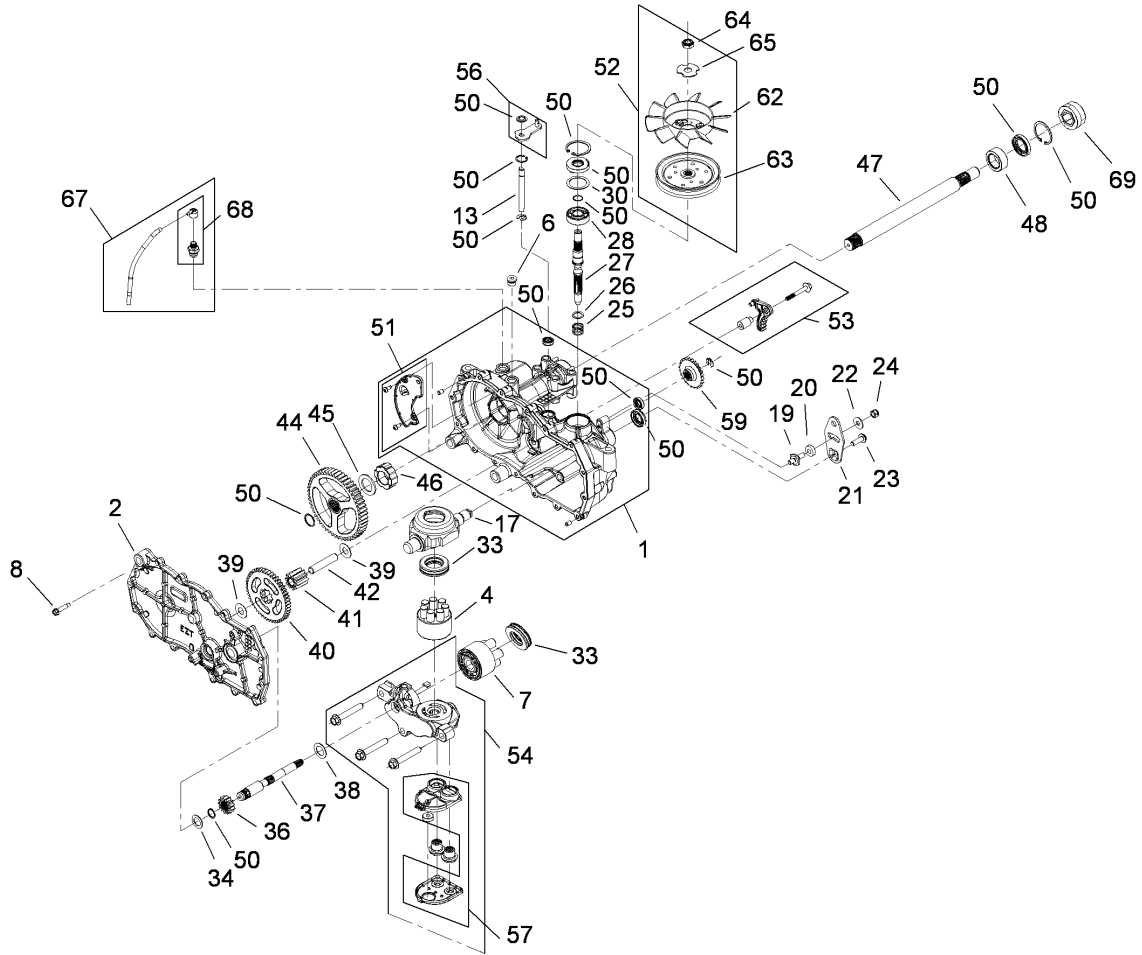

LH Hydro Assembly No. 110-6770

Ref	Part No.	Qty.	Description
1	114-1636	1	LH Main Housing ASM
2	114-1637	1	LH Side ASM
4	110-8561	1	Pump Block ASM
6	104-2189	1	Plug-Thread, Straight
7	103-2666	1	Cylinder Block Kit
8	104-5305	16	Screw-HHF
13	106-8678	1	Rod-Bypass
17	104-5304	1	Swashplate-Trunnion
19	104-2116	1	Stud
20	112-9853	1	Puck-Friction
21	106-8747	1	Arm-Control
22	5-4460	1	Washer-Pivot
23	107-2488	1	Screw
24	105-1872	1	Nut
25	94-1936	1	Spring-Block
26	94-1937	1	Washer-Thrust, Block
27	104-5306	1	Shaft-Input
28	104-5311	1	Bearing-Ball
30	104-5308	1	Spacer
33	94-6922	2	Bearing-Thrust
34	104-5339	1	Washer-Flat
36	104-5316	1	Gear-Pinnion, 13T
37	114-1632	1	Shaft-Motor
38	104-5360	1	Washer-Shaft, Motor

Ref	Part No.	Qty.	Description
39	94-1933	2	Washer
40	104-5317	1	Gear
41	104-5318	1	Gear-Jackshaft, 10T
42	104-5329	1	Pin-Jackshaft
44	112-9855	1	Gear-52T, Bull
45	112-9856	1	Washer
46	112-9857	1	Bearing-Sleeve
47	112-9858	1	Shaft-Axle
48	112-9859	1	Bushing-Axle
50	106-8686	1	Seal Kit
51	106-8687	1	LH Expansion Plate Kit
52	106-8698	1	Fan Pulley Kit
53	114-1633	1	Brake Arm Kit
54	112-9862	1	LH Center Section Filter Kit
55	104-2147	1	Sealant
56	107-2489	1	Bypass Arm Kit
57	114-1634	1	Filter Kit
59	106-8694	1	Disc-Brake, Cog
62	110-8566	1	Fan-6 Inch, 10 Blade
63	104-1754	1	Pulley
64	105-1875	1	Nut-Lock
65	107-9122	1	Washer-Slotted
67	112-9866	1	Breather Kit
68	114-1635	1	Breather ASM

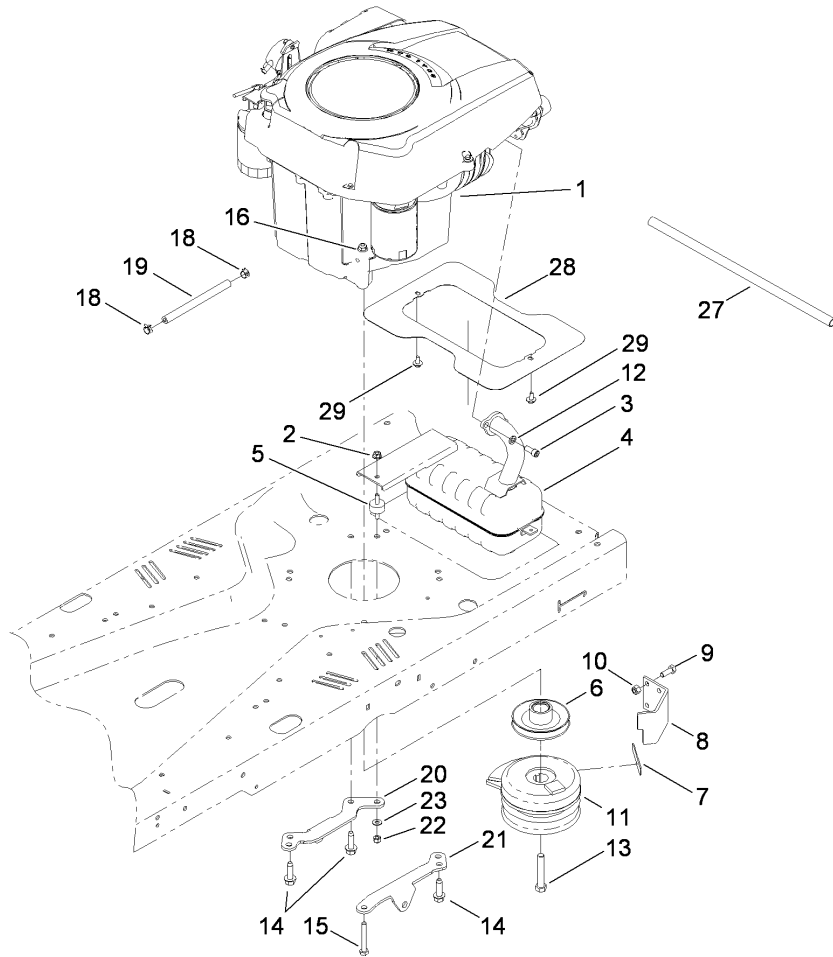

Engine, Muffler and Clutch Assembly

Ref	Part No.	Qty.	Description
1		1	Engine-Kohler, Sv610-0020
2	32128-33	1	Nut-HF
3	3274-10	2	Screw-HSH
4	112-4024	1	Muffler-Kohler
5	112-3976	1	Isolator
6	114-1622	1	Pulley-Engine
7	112-4033	1	Bumper
8	110-6896	1	Stop-Clutch
9	322-4	2	Screw-HH
10	3296-29	2	Nut-Lock, NI
11	104-3334	1	Clutch-Electric
12	3253-4	2	Washer-Lock
13	3212-10	1	Screw-HH
14	32144-109	3	Screw
15	322-11	1	Screw-HH
16	104-8300	1	Nut-Flange, NI
18	2412-98	2	Clamp
19	109-0306	1	Hose-Fuel
20	110-6798	1	Support-Hydro, RH
21	110-6799	1	Support-Hydro, LH
22	3296-42	1	Nut-Lock, NI
23	3256-22	1	Washer-Flat
27	106-7022	1	Tube-Drain, Oil
28	114-8544	1	Shield-Heat

Ref	Part No.	Qty.	Description
29	46-8560	2	Screw-HHF

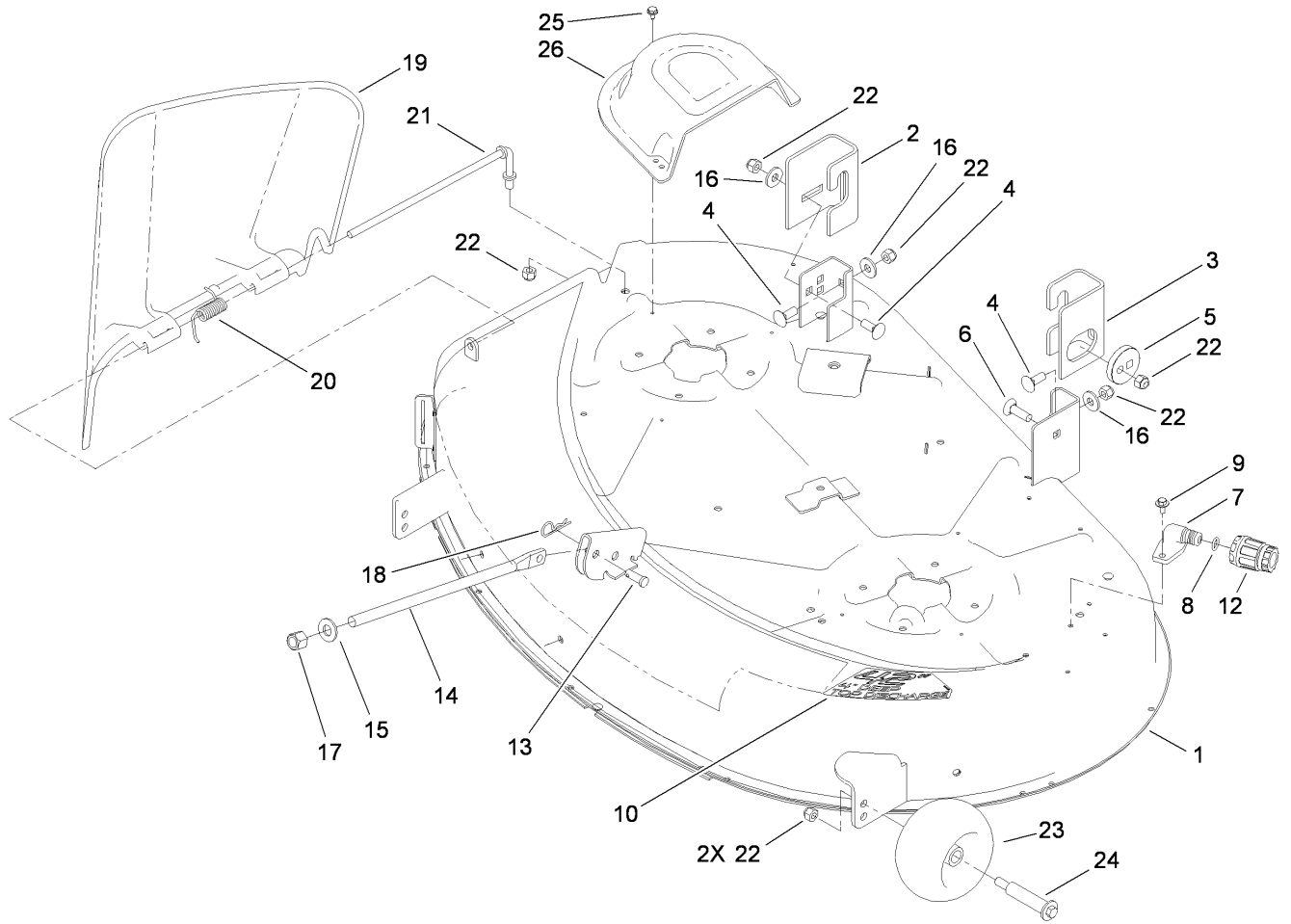

42 Inch Deck Assembly

Ref	Part No.	Qty.	Description
1	117-1290	1	42 Inch Deck ASM
2	108-7836	1	Bracket-Hanger, Right Rear
3	108-7838	1	Bracket-Hanger, Left Rear
4	3231-2	3	Screw-CARR
5	112-3980	1	Eccentric
6	3231-28	1	Screw-CARR
7	95-2747	1	Fitting-Washout
8	46-6290	1	O-Ring, Seal
9	46-8560	2	Screw-HHF
10	117-1222	1	Decal-42 Inch
12	95-3270	1	Connector-Hose
13	1-808284	1	Pin-Clevis
14	108-7847	1	Rod-Lift
15	87-7270	1	Washer-Thrust
16	80-6990	3	Washer-Hardened
17	3296-23	1	Nut-Lock, NI
18	9335054	1	Pin-Hair
19	112-3951	1	Deflector-42 Inch
20	110-6694	1	Spring-Torsion
21	112-4026	1	Rod-Pivot
22	3296-39	7	Nut-Lock, NI
23	1-603299	2	Roller-Scalp, Anti
24	112-3977	2	Bolt-Shoulder
25	32104-76	6	Screw

Ref	Part No.	Qty.	Description
26	108-7889	2	Cover-Belt

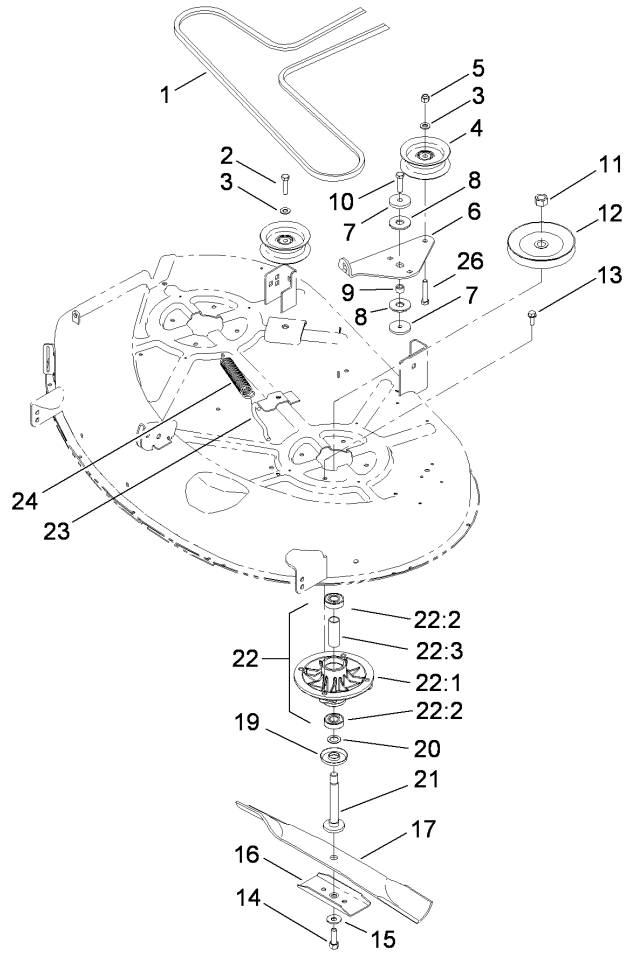

42 Inch Deck Spindle and Belt Drive Assembly

Ref	Part No.	Qty.	Description
1	110-6871	1	V-Belt
2	323-9	1	Screw-HH
3	3256-24	2	Washer-Flat
4	106-2175	2	Pulley-Idler, Flat
5	3296-39	1	Nut-Lock, NI
6	114-8540	1	Arm-Idler
7	110-9981	2	Washer-Plain
8	114-0463	2	Washer-Friction, Composite
9	115-4986	1	Spacer
10	323-8	1	Screw-HH
11	3219-6	2	Nut-Hex
12	110-6864	2	Pulley
13	32144-41	8	Screw-Taptite
14	26-0671	2	Screw-HH
15	3290-465	2	Washer-Belleville
16	106-2248-03	2	Stiffener-Blade
17	110-6568-03	2	Blade-21.6 Inch
19	80-4360	2	Shield-Bearing
20	80-4380	2	Spacer
21	110-6866	2	Shaft-Spindle
22		2	Spindle ASM
22:1	88-4510	1	Housing-Spindle
22:2	100-1048	2	Bearing-Ball
22:3	62-3661	1	Spacer

Ref	Part No.	Qty.	Description
23	88-5970	1	Hook-Return, Spring
24	106-2177	1	Spring-Extension
26	323-10	1	Screw-HH

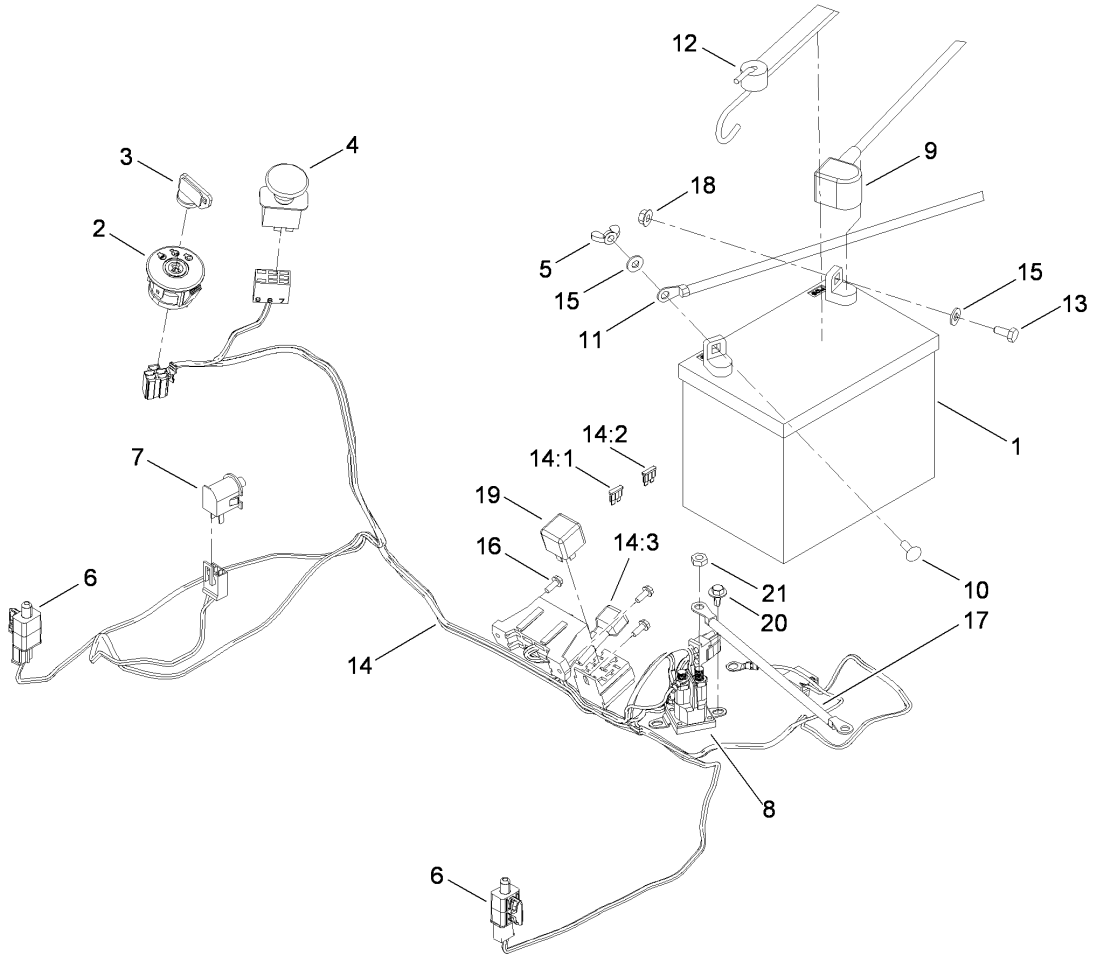

Electrical Assembly

Ref	Part No.	Qty.	Description
1	104-2493	1	Battery
2	110-6764	1	Switch-Ignition
3	63-8360	1	Key-Ignition
4	93-9998	1	Switch-PTO
5	32103-22	1	Nut-Wing
6	110-6765	2	Switch-Single Pole No
7	82-2190	1	Switch-Bail
8	117-1197	1	Solenoid
9	110-6794	1	Cable-Battery, Red
10	3229-1	1	Screw-CARR
11	110-6793	1	Cable-Battery, Black
12	104-2466	1	Holddown-Battery
13	321-3	1	Screw-HH
14	117-1276	1	Harness-Wiring
14:1	109103	1	Fuse-30 Amp
14:2	109102	1	Fuse-25 Amp
14:3	100-4918	1	Diode
15	3256-22	2	Washer-Flat
16	32144-1	3	Screw-Taptite
17	110-6792	1	Cable-Battery, Red
18	32128-33	2	Nut-HF
19	98-7249	1	Relay
20	46-8560	2	Screw-HHF
21	3220-2	2	Nut-Jam

Attachments and Accessories

For 74363 - TimeCutter Z4220 Riding Mower

Product Name	Model/Part
Armrest Kit	108-6163
Smooth Tread Front Tire Kit	110-6739
Hour Meter Kit	112-9763
42 Inch Blowout Ring Kit	114-1620
Striping Kit	114-8545
Armrest Kit	79212
42 Inch Replacement Blade Kit	79220
42 Inch Recycler Kit	79311
Foot Assist Cutting Unit Lift Kit	79313
Engine Cover Kit	79314
Floor Mat Kit	79315
Rear Engine Guard	79316
Storage Cover	79317
Rear Hitch Kit	79318
Sunshade	79319
42 Inch and 50 Inch Twin Bagger	79324
10 cu. ft. Poly Dump Cart	79991
125 lb. Tow Spreader	79993
42 Inch Sweeper	79994
48 Inch Dethatcher	79995
40 Inch Spike Aerator	79996
Stake Side Kit	79997

NOTES

