



# ROPS CERTIFIED DELUXE HARD CAB

This cab is to be used on the following products and not to be used on any other units:

**WORKMAN®**

HD, HDX, HDX-D

HDX 4WD, HDX-D 4WD

## Model 07339 Operators Manual Installation Instructions



**⚠ CAUTION:** Read and follow all safety statements and assembly instruction, before attempting to mount or operate vehicle with sunshade installed.

**⚠ CAUTION:** The resulting noise levels when using this product will exceed OSHA standards for an 8 hour work day and hearing protection with a Noise Reduction Rating (NRR) of 22 or higher is required

**⚠ CAUTION:** This unit is heavy, and should be mounted with a minimum of two personnel and a hoist.

**⚠ INSTALLER:** Leave these instructions with end user. If Manual is lost or damaged, please contact your Toro dealer/distributor for replacement.

**⚠ END USER:** Keep this manual for future reference.

## Table of contents

1. Safety instructions.....	3
2. Inspection guide.....	5
3. Safety labels and location.....	6
4. Operation instructions.....	7
5. Vehicle preparation.....	8
6. Cab installation.....	9
7. Parts list.....	12
8. Parts photos.....	13
9. Optional equipment.....	13
10. To the purchaser.....	14
11. Warranty policy.....	15

# SAFETY INSTRUCTIONS

## BEFORE OPERATING

- Read and understand the contents of this material before operating the vehicle. Become thoroughly familiar with the controls, capabilities and proper use of equipment.
- This cab fits all Workman® HD Series with serial numbers 29xxxxxxx or higher.
- **DO NOT** weld, cut, drill, or modify cab structure in any matter.
- **DO NOT** allow children to operate vehicle. Do not allow adults to operate with out proper training.
- Keep all shields and safety devices in place. If a safety device, shield, or decal malfunctions, becomes damaged or illegible replace it before operating is recommended. To assure vehicle is in safe operating condition, tighten any loose nuts, bolts, and screws.
- A cab with doors reduces the payload capacity of the vehicle by 440 lbs.[200 Kg]. Cab with out doors 330 lbs. [150 Kg].

# SAFETY INSTRUCTIONS

## While operating

- Verify capacity rating for the vehicle. Make sure that the GVW capacities are not exceeded.
- Avoid sudden stops or sharp turns.
- Always use safety belts.
- Never allow riders on top of cab or in bed while operating vehicle.
- Stay alert for hidden hazards and traffic.
- Avoid sudden starts and excessive speeds.
- Use extreme care when working around fences, ditches or on hillsides.
- Check clearances carefully before driving under any objects.
- Avoid operating sideways on a steep slope whenever possible.
- Wait for vehicle to come to a full stop and engage parking brake before leaving vehicle.

## Maintenance

- To insure cab is in safe operating condition, keep all fasteners tight.
- Replace a damaged cab. Do not repair or revise. Any alterations to a cab must be approved by manufacturer.
- To be sure of optimum performance and safety, always purchase genuine TORO replacement parts and accessories. Replacement parts and accessories not made by the TORO approved manufacturer could be dangerous. Such use could void warranty of the TORO COMPANY.
- Thoroughly inspect cab and cab mounting periodically.

# **ROPS Certified Cab, Roll Over Protection Structure Inspection Guide**

## **Cab has been certified to ISO 21299**

ROPS certified cab like any other safety device needs to be periodically inspected to verify that the integrity of the device has not been compromised through normal machine use, misuse, age degrading, modifications, or rollovers.

Some mechanical discretion is essential, therefore personnel who inspect the cab need to comprehend and understand the significance of issues like structural corrosion, cracks, and deformation. Conservatism is the essential rule. If in doubt, remove the machine from service and contact cab manufacturer for assistance. Examples are:

- Permanent deformation or twisting.
- Missing, damaged, or loose mounting hardware.
- Mounting hardware that is of a grade lesser than specified.
- Any cracks in structure (structural members and/or welds).
- Significant corrosion.
- Modifications, i.e. unauthorized welds or holes.
- Missing or unreadable labels.
- Machine GVW (including attachments, restrained payload, fuel and operator) in excess of the maximum weight specified on the machine label.
- Missing or unusable operator restraint devices. (i.e. seat belts)
- Any unauthorized repair.
- Incomplete/improper installation.

Other conditions may require imminent service but may not render the unit immediately unusable. Examples are:

- Faded paint.
- Faded hard to read labels.
- Heavily soiled operator restraints. (seat belts)
- Slightly corroded mounting hardware.
- Cab must be inspected immediately after any type of collision, rollover, or impact. If any damage is evident, the cab must be removed from service, repaired and/or replaced.
- When cab is removed or reinstalled, mounting hardware must be examined for signs of over stressing. Damaged mounting hardware must be replaced before placing the cab back in service.
- Operators are to be instructed to properly adjust and use restraints, seatbelts, at all times.

Replace decals immediately if damaged or missing.



Part No: 117-4955 Located on  
right and left rear door post

Warning - read the Operator's  
Manual; wear the seat belt,  
avoid tipping the machine.

Warning – wear hearing  
protection.

# Operation Instructions

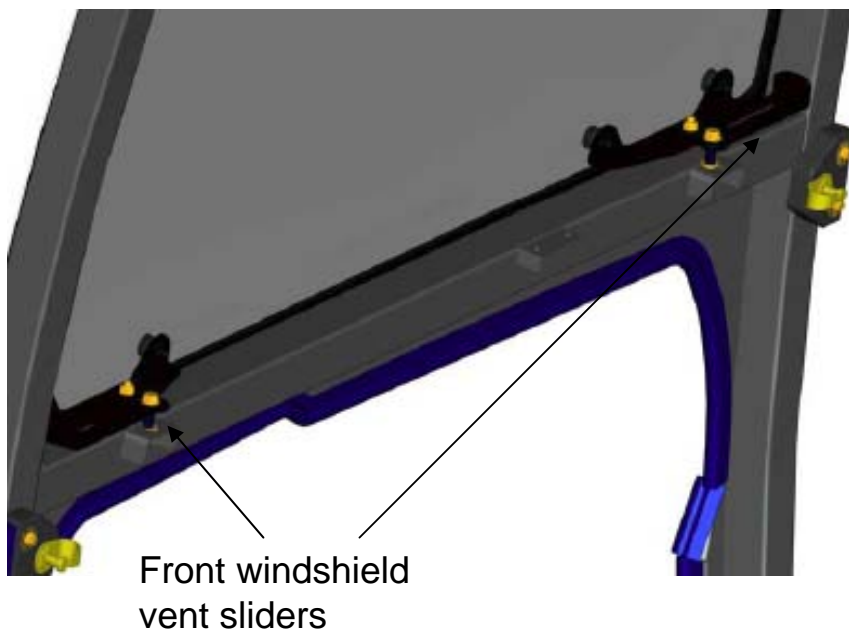
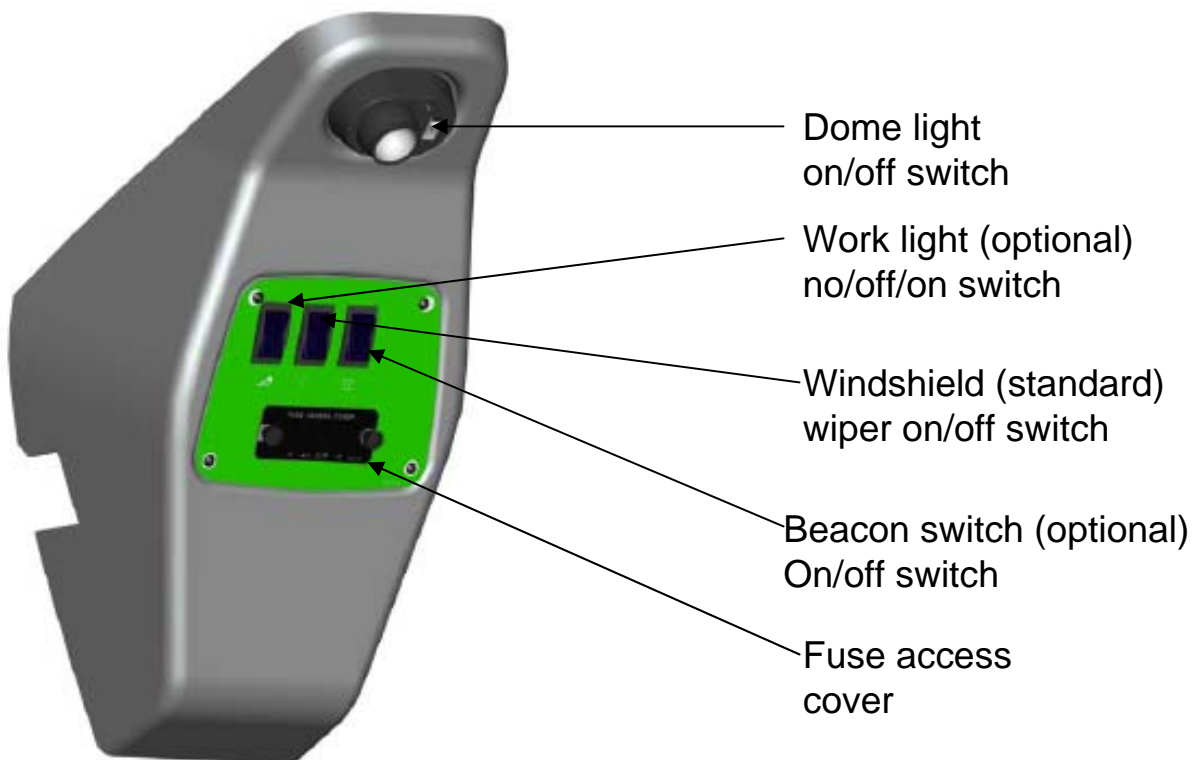

# Vehicle Preparation

## Preparation of Workman

1. Position the vehicle on a clean level surface, raise or remove bed, stop engine, engage parking brake and remove key from ignition.
2. Disconnect positive battery cable.

## Installation of compression springs (White springs)

3. Remove ROPS and retain bolts (6). (see Figure 1)
4. Remove (4) socket head screws that secure each seat to vehicle. Lift both seats from vehicle.
5. Remove knobs from control levers, then remove center console control plate assembly.
6. Disconnect radiator overflow tank hose at radiator and plug hose.
7. Carefully lift seat base from vehicle.
8. Jack up front of vehicle and secure with jack stands. (see lifting instructions in the Workman Operators Manual)
9. Remove front wheels.
10. Remove front shock absorbers.
11. Remove screws that hold lift valve on center console. (see figure 3)
12. Remove screws that mount center console and move console out of the way to have better access to suspension springs. No need to disconnect any of the cables. (see figure 2)
13. Install compression spring tool rod through holes in each spring cradle, then install nuts and washers on both ends of each rod. Tighten one nut on each rod to secure springs.

Note: Extended portion of each compression spring tool must be on opposite ends so cap screws can be removed.

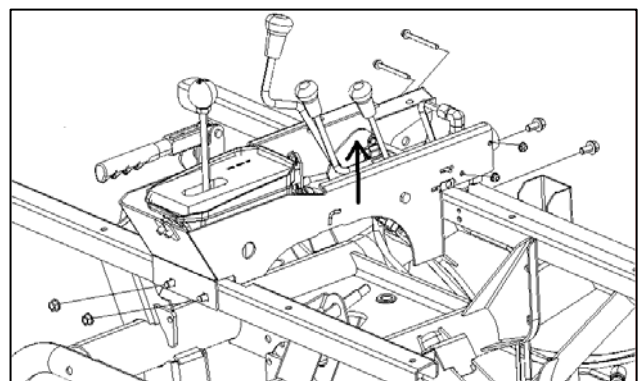
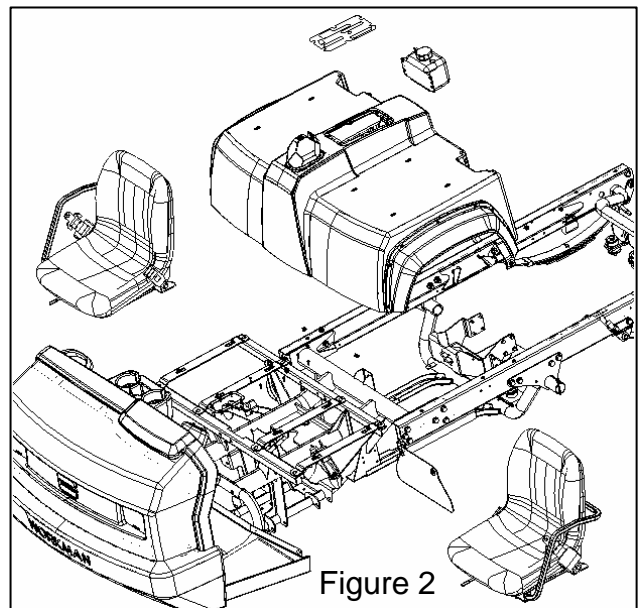
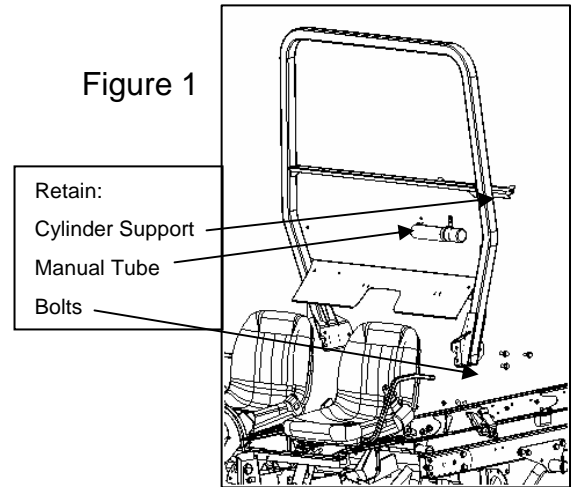

## Vehicle Preparation continued

14. Remove lock nut and cap screw from form lower end of each stabilizer link. (see figure 4)
15. Remove lock nut and cap screw securing each spring cradle along with the stabilizer links.
16. Reverse procedures 5 through 13, to install compression springs provided in the kit.
17. Remove Hood and unplug headlights.

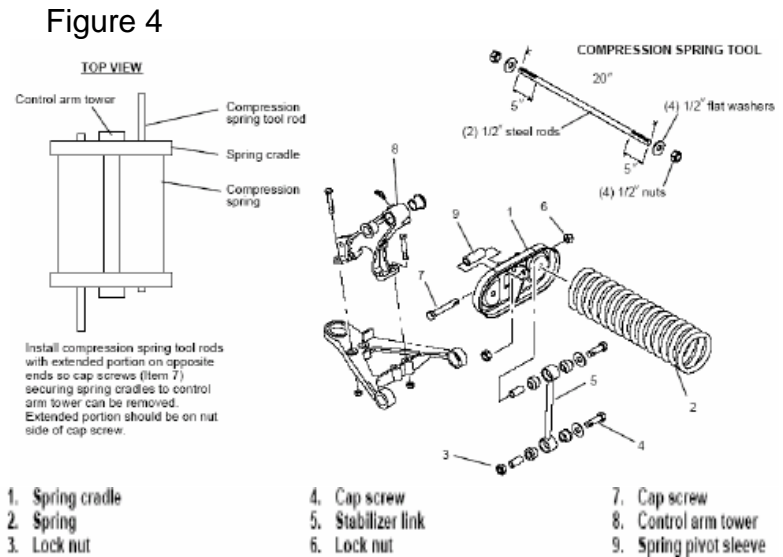

## Cab Installation

1. Install rear cab mounts using fasteners retained from OEM ROPS. Figure 1
2. Install front mounts using 3/8" x 1" bolts with 3/8" flat washers outside and 3/8" flange nut underneath. Figure 2
3. Take cab lift brackets and slide bolt through holes in top of cab. Figure 3
4. Lift cab off shipping pallet with hoist. (Warning cab is heavy use caution when maneuvering cab, cab damage or personal injury could occur)

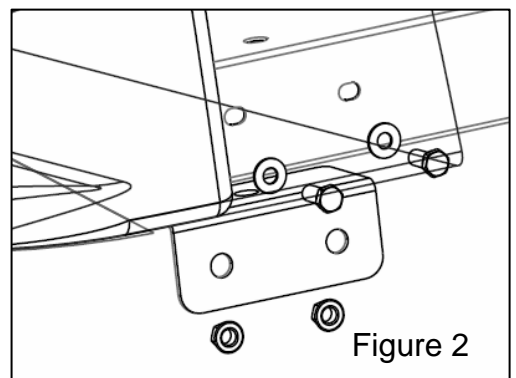
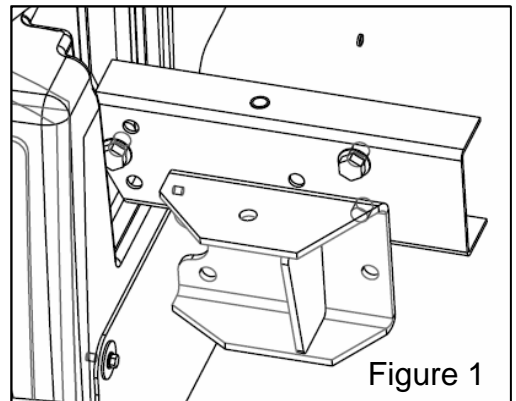

## Cab Installation continued

5. Position mounting pads on mounting holes. Figure 4

6. Lower cab and line up the mounting holes on the cab with the isolator pads.

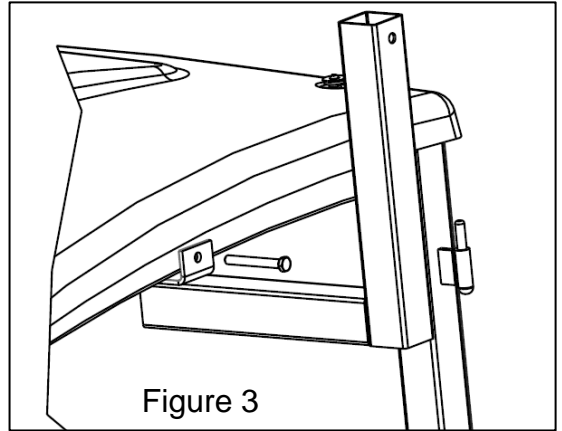

Figure 3

7. Using all mounting bolt hardware finger tighten each bolt as you line it up so you can maneuver the cab into line with the other holes.

8. Re-install seats.

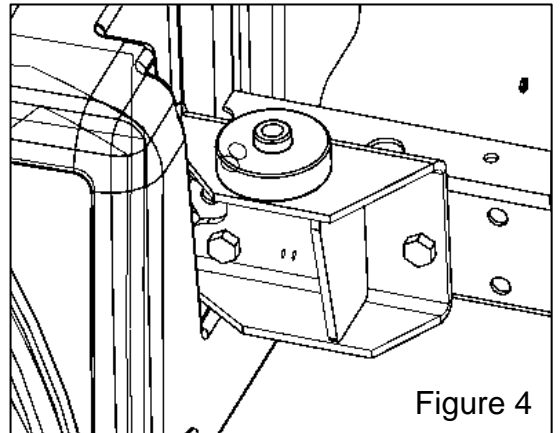

Figure 4

9. Tighten cab mounting bolts.

10. Install owners manual taken from OEM ROPS and mount behind drivers seat in cab. Figure 5

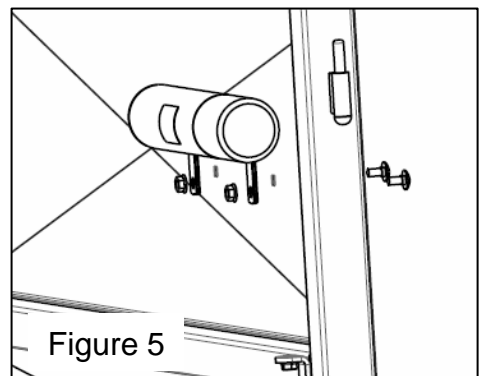

Figure 5

11. Install cylinder support taken off OEM ROPS and install into tabs on rear of cab. Figure 6

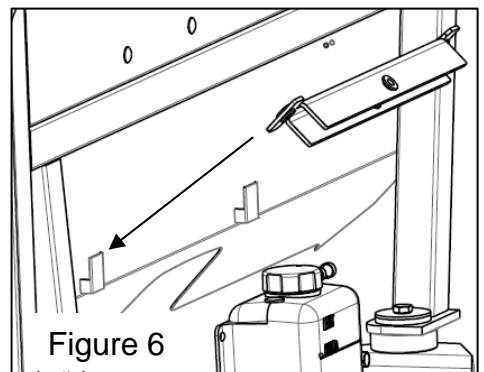
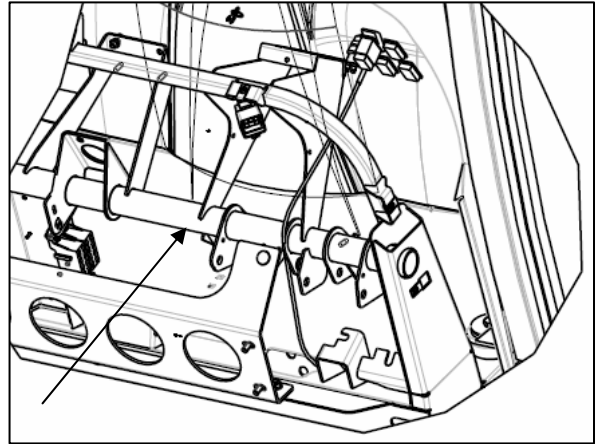

Figure 6

## Cab Installation continued

12. Run wire harness over tube and along front brace making sure that no moving parts rub against it.

Figure 7



13. Plug red wire with spade connector with into the spare power lead coming out of the fuse block.

Figure 8

14. Install ground wire onto ground block.

15. Reinstall hood and reconnect headlights.

16. Reconnect the positive battery cable.

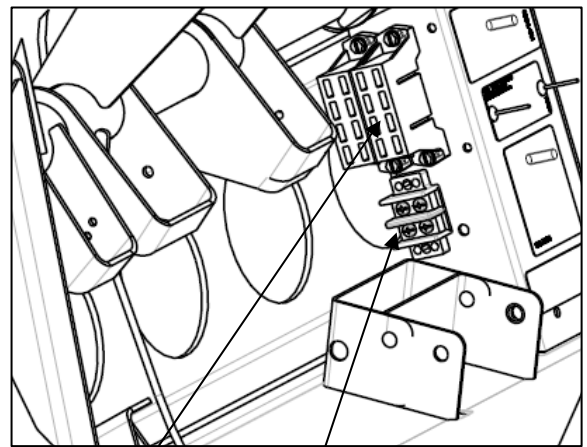

Fuse Block

Ground Block

Figure 8

# Standard Parts List

Qty	Description
2	Rear brackets (LH & RH)
2	Front Brackets
4	Bolt, 3/8" x 1"
4	Flat washer 3/8"
1	Lift bracket set
2	Bolt, 3/8" x 3"
6	Flange Lock Nuts, 3/8"
2	Plugs, 3/8"
4	Bolt, 1/2" x 3"
4	Washers rubber
4	3" Isolator pad rubber
4	Flange Lock Nut, 1/2"
4	Washers 9/16" ID 2 1/2" OD
2	Heavy-duty springs (white)

# Standard Electrical Parts List

Qty	Description
1	20 AMP Fuse

# Parts Photos

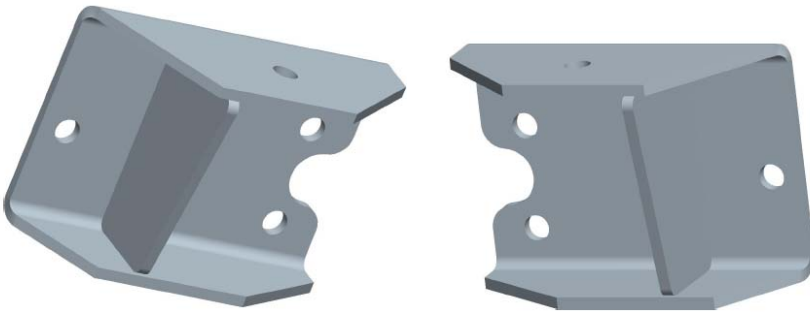

Rear mount brackets, L&R

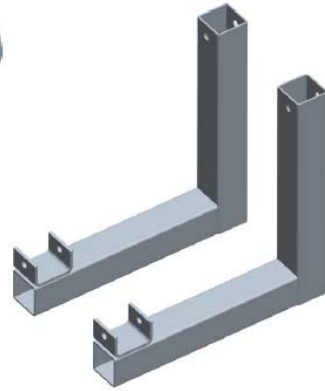

2" Lift Bracket set



Front mount Brackets, L&R

## Optional equipment for Toro Workman HD Series

Option	Part No.
Sliding door kit	07375
Solid door kit	07376
Heater kit	07374
Mirror kit	117-4830
Defrost fan (Available thru Jodale Perry)	
Work light kit (Available thru Jodale Perry)	
Rotating beacon (Available thru Jodale Perry)	

Jodale Perry Corporation  
 204-822-9100  
[www.jodaleperry.com](http://www.jodaleperry.com)

## TO THE PURCHASER

All products are designed to give safe, dependable service if they are operated and maintained according to instructions. Read and understand this manual before installation or operation.

This manual has been prepared to assist the owner and operators in the safe installation, and suitable maintenance of this cab. The information is applicable to products at the time of manufacture and does not include modifications made afterwards.

Read and understand mounting instructions before attempting to mount cab. Familiarize yourself with the operating instructions and all safety recommendations contained in this manual, and on the tractor. Follow the safety recommendations and make sure that those with whom you work follow them.

### **DIRECTION REFERENCE**

All references to right and left, forward or rearward, are from the operators' seat, facing the steering wheel.

*To assist you dealer in handling your needs, please record hereafter the model number and serial number of your cab and tractor. It is also advisable to supply them to your insurance company. It will be helpful in the event that the cab or tractor is lost or stolen.*

**TRACTOR CAB:** \_\_\_\_\_  
**MODEL:** \_\_\_\_\_  
**SERIAL NUMBER:** \_\_\_\_\_  
**DATE OF PURCHASE:** \_\_\_\_\_  
**DEALER NAME:** \_\_\_\_\_

## Toro General Commercial Products Warranty

### A Two-Year Limited Warranty

#### Conditions and Products Covered

The Toro Company and its affiliate, Toro Warranty Company, pursuant to an agreement between them, jointly warrant your Toro Commercial Product ("Product") to be free from defects in materials or workmanship for two years or 1500 operational hours\*, whichever occurs first. This warranty is applicable to all products with the exception of Aerators (refer to separate warranty statements for these products). Where a warrantable condition exists, we will repair the Product at no cost to you including diagnosis, labor, parts, and transportation. This warranty begins on the date the Product is delivered to the original retail purchaser.

\* Product equipped with hour meter

#### Instructions for Obtaining Warranty Service

You are responsible for notifying the Commercial Products Distributor or Authorized Commercial Products Dealer from whom you purchased the Product as soon as you believe a warrantable condition exists. If you need help locating a Commercial Products Distributor or Authorized Dealer, or if you have questions regarding your warranty rights or responsibilities, you may contact us at:

Toro Commercial Products Service Department  
Toro Warranty Company  
8111 Lyndale Avenue South  
Bloomington, MN 55420-1196  
952-888-8801  
E-mail: commercial.warranty@toro.com

#### Owner Responsibilities

As the Product owner, you are responsible for required maintenance and adjustments stated in your *Operator's Manual*. Failure to perform required maintenance and adjustments can be grounds for disallowing a warranty claim.

#### Items and Conditions Not Covered

Not all product failures or malfunctions that occur during the warranty period are defects in materials or workmanship. This warranty does not cover the following:

- Product failures which result from the use of non-Toro replacement parts, or from installation and use of add-on, or modified non-Toro branded accessories and products. A separate warranty may be provided by the manufacturer of these items.
- Product failures which result from failure to perform recommended maintenance and/or adjustments. Failure to properly maintain your Toro product per the Recommended Maintenance listed in the *Operator's Manual* can result in claims for warranty being denied.
- Product failures which result from operating the Product in an abusive, negligent or reckless manner.
- Parts subject to consumption through use unless found to be defective. Examples of parts which are consumed, or used up, during normal Product operation include, but are not limited to, brakes pads and linings, clutch linings, blades, reels, bed knives, tines, spark plugs, castor wheels, tires, filters, belts, and certain sprayer components such as diaphragms, nozzles, and check valves, etc.
- Failures caused by outside influence. Items considered to be outside influence include, but are not limited to, weather, storage practices, contamination, use of unapproved coolants,

lubricants, additives, fertilizers, water, or chemicals, etc.

- Normal noise, vibration, wear and tear, and deterioration.
- Normal "wear and tear" includes, but is not limited to, damage to seats due to wear or abrasion, worn painted surfaces, scratched decals or windows, etc.

#### Parts

Parts scheduled for replacement as required maintenance are warranted for the period of time up to the scheduled replacement time for that part. Parts replaced under this warranty are covered for the duration of the original product warranty and become the property of Toro. Toro will make the final decision whether to repair any existing part or assembly or replace it. Toro may use remanufactured parts for warranty repairs.

#### Note Regarding Deep Cycle Battery Warranty:

Deep cycle batteries have a specified total number of kilowatt-hours they can deliver during their lifetime. Operating, recharging, and maintenance techniques can extend or reduce total battery life. As the batteries in this product are consumed, the amount of useful work between charging intervals will slowly decrease until the battery is completely worn out. Replacement of worn out batteries, due to normal consumption, is the responsibility of the product owner. Battery replacement may be required during the normal product warranty period at owner's expense.

#### Maintenance Is at Owner's Expense

Engine tune-up, lubrication cleaning and polishing, replacement of filters, coolant, and completing Recommended Maintenance are some of the normal services Toro products require that are at the owner's expense.

#### General Conditions

Repair by an Authorized Toro Distributor or Dealer is your sole remedy under this warranty.

Neither The Toro Company nor Toro Warranty Company is liable for indirect, incidental or consequential damages in connection with the use of the Toro Products covered by this warranty, including any cost or expense of providing substitute equipment or service during reasonable periods of malfunction or non-use pending completion of repairs under this warranty. Except for the Emissions warranty referenced below, if applicable, there is no other express warranty. All implied warranties of merchantability and fitness for use are limited to the duration of this express warranty.

Some states do not allow exclusions of incidental or consequential damages, or limitations on how long an implied warranty lasts, so the above exclusions and limitations may not apply to you. This warranty gives you specific legal rights, and you may also have other rights which vary from state to state.

#### Note regarding engine warranty:

The Emissions Control System on your Product may be covered by a separate warranty meeting requirements established by the U.S. Environmental Protection Agency (EPA) and/or the California Air Resources Board (CARB). The hour limitations set forth above do not apply to the Emissions Control System Warranty. Refer to the Engine Emission Control Warranty Statement printed in your *Operator's Manual* or contained in the engine manufacturer's documentation for details.

#### Countries Other than the United States or Canada

Customers who have purchased Toro products exported from the United States or Canada should contact their Toro Distributor (Dealer) to obtain guarantee policies for your country, province, or state. If for any reason you are dissatisfied with your Distributor's service or have difficulty obtaining guarantee information, contact the Toro Importer.