



Service Manual

Reelmaster[®] 450-D

Preface

The purpose of this publication is to provide the service technician with information for troubleshooting, testing, and repair of major systems and components on the Reelmaster 450-D.

REFER TO THE TRACTION UNIT AND CUTTING UNIT OPERATOR'S MANUALS FOR OPERATING, MAINTENANCE AND ADJUSTMENT INSTRUCTIONS. Space is provided in Chapter 2 of this book to insert the Operator's Manuals and Parts Catalogs for your machine. Replacement Operator's Manuals are available by sending complete Model and Serial Number to:

The Toro Company
8111 Lyndale Avenue South
Minneapolis, MN 55420

The Toro Company reserves the right to change product specifications or this publication without notice.



This safety symbol means DANGER, WARNING, or CAUTION, PERSONAL SAFETY INSTRUCTION. When you see this symbol, carefully read the instructions that follow. Failure to obey the instructions may result in personal injury.

NOTE: A NOTE will give general information about the correct operation, maintenance, service, testing or repair of the machine.

IMPORTANT: The IMPORTANT notice will give important instructions which must be followed to prevent damage to systems or components on the machine.

Table Of Contents

Chapter 1 – Safety

Safety Instructions 1 – 1

Chapter 2 – Product Records and Manuals

Product Records 2 – 1

Equivalents and Conversions 2 – 2

Torque Specifications 2 – 3

Equipment Operational and
Service Historical Report Record 2 – 5

Chapter 3 – Engine

Specifications 3 – 1

Service Manual, Mitsubishi 4DQ5 Diesel Engine

Service Manual Supplement, Fuel System

Chapter 4 – Hydraulic System

Specifications 4 – 1

Hydraulic Hose and Fitting Information 4 – 2

Schematics 4 – 4

Troubleshooting 4 – 16

Testing 4 – 22

Eaton Char–Lynn Steering Control Repair Information

Cessna Service Instructions

Vickers Gear Pump Service Manual

Auburn Gear Power Wheel

Planetary Gear Drive Service Manual

Chapter 5 – Electrical System

Specifications 5 – 1

Electrical Schematics (S/N 60001 – 80100) 5 – 2

Electrical Schematic (S/N 80101 – 09999) 5 – 12

Electrical Schematic (S/N 10001 & UP) 5 – 13

Chapter 6 – Cutting Units

Specifications 6 – 2

Special Tools 6 – 3

Adjustments 6 – 5

Repairs 6 – 9



Table of Contents

SAFETY INSTRUCTIONS	1	While Doing Maintenance, Troubleshooting, Testing, Adjustments or Repairs	2
Before Operating	1		
While Operating	2		

Safety Instructions

The Reelmaster 450D has been tested and verified for compliance with the B71.4-1984 specifications of the American National Standards Institute (ANSI) for riding mowers when rear tires are filled with calcium chloride and two rear wheel weight kits (Part No. 11-0440) are installed. However, improper use or maintenance by the owner or operator of the machine can result in personal injury.



CAUTION

Obey the following safety instructions. Read and understand these instructions before operating the Reelmaster 450D or doing maintenance, troubleshooting, testing, adjustments or repairs. Failure to comply with the safety instructions may result in personal injury.

Before Operating

1. Read and understand the Operator's Manual before starting, operating, maintaining or repairing the machine. Replacement Operator's Manuals are available by sending complete Model and Serial Number of traction unit and cutting unit to:

The Toro Company
8111 Lyndale Avenue South
Minneapolis, MN 55420

Use the Model and Serial Number when referring to your machine. If you have questions about this Service Information, please contact:

The Toro Company
Commercial Service Department
8111 Lyndale Avenue South
Minneapolis, MN 55420

2. Never allow children to operate the machine or adults to operate it without proper instruction.

3. Become familiar with the controls and know how to stop the machine and engine quickly.

4. Keep all shields, safety devices and decals in place. If a shield, safety device or decal is defective or damaged, repair or replace it before operating the machine.

5. Always wear substantial shoes. Do not operate machine wearing sandals, tennis shoes, sneakers or when barefoot. Do not wear loose fitting clothing that could get caught in moving parts and possibly cause personal injury.

6. Wearing safety glasses, safety shoes, long pants and a helmet is advisable and required by some local ordinances and insurance regulations.

7. Make sure the work area is clear of objects which might be picked up and thrown by the reels.

8. Do not carry passengers on the machine. Keep everyone, especially children and pets, away from the areas of operation.

9. Since diesel fuel is highly flammable, handle it carefully:

A. Use an approved fuel container.

B. Do not remove fuel tank cap while engine is hot or running.

C. Do not smoke while handling fuel.

D. Fill fuel tank outdoors and only to within an inch (25 mm) from the top of the tank, not the filler neck. Do not overfill.

E. Wipe up any spilled fuel.

While Operating

10. Do not run engine in a confined area without adequate ventilation. Exhaust is hazardous and could be deadly.

11. Sit on the seat when starting and operating the machine.

12. Check interlock switches daily for proper operation. If a switch fails, replace it before operating the machine. The interlock system is for your protection, so do not bypass it. Replace all interlock switches every two years.

13. Before starting the engine each day, test lamps, warning buzzer and signal lights to assure proper operation.

14. Pay attention when using the machine. To prevent loss of control:

A. Mow only in daylight or when there is good artificial light.

B. Watch for holes or other hidden hazards.

C. Be extremely careful when operating close to sand traps, ditches, creeks, steep hillsides or other hazards.

D. Reduce speed when making sharp turns. Avoid sudden stops and starts. Use ground speed limiter lever to set pedal travel so excessive ground speed will be avoided during mowing and transport.

E. Look to the rear to assure no one is behind the machine before backing up.

F. Watch for traffic when near or crossing roads. Always yield the right-of-way.

G. Reduce speed when driving downhill.

15. Keep hands, feet and clothing away from moving parts and the reels.

16. Raise cutting units and latch them securely in transport position before driving from one work area to another.

17. Do not touch engine, muffler or exhaust pipe while engine is running or soon after it is stopped. These areas could be hot enough to cause burns.

18. If cutting unit strikes a solid object or vibrates abnormally, stop immediately, turn engine off, set parking brake and wait for all motion to stop. Inspect for damage. If reel or bedknife is damaged, repair or replace it before operating. Do not attempt to free blocked cutting unit by moving Mow/Backlap lever rapidly between FORWARD and BACKLAP. Damage to system may result. Lever should easily return and hold in the STOP position.

19. Before getting off the seat:

A. Move traction pedal to neutral.

B. Set parking brake.

C. Disengage cutting units and wait for reels to stop.

D. Stop engine and remove key from switch.

E. Do not park on slopes unless wheels are chocked or blocked.

20. The optional TORO tow bar is for emergency towing only. Use only the special tow bar if necessary to tow. Use a trailer for normal transport.

While Doing Maintenance, Troubleshooting, Testing, Adjustments or Repairs

21. Stop the engine and remove the key from the ignition switch before servicing or making adjustments. Also disconnect the negative (-) cable from the battery. Secure the cable off to the side. This will prevent sparks, electrical shocks, or accidental starting of the engine when servicing, cleaning, adjusting, or storing the machine. If battery voltage is required for troubleshooting or test procedures, temporarily connect the battery.
22. If the engine must be running to perform an inspection or procedure, use extreme caution. Always use two people, with the operator at the controls able to see the person doing the inspection or procedure. Keep hands, feet, clothing, and body away from cutting units and other moving parts.
23. Be sure you understand a service procedure before working on the machine. Unauthorized modifications to the machine may impair the function, safety and life of the machine. If major repairs are ever needed, or assistance is desired, contact your TORO Distributor.
24. Make sure the entire machine is properly maintained and in good operating condition. Frequently tighten all nuts bolts. and screws.
25. Frequently tighten all hydraulic line connectors and fittings. Make sure all hydraulic hoses and lines are in good condition before applying pressure to the system.
26. Keep body and hands away from pin hole leaks or nozzles that eject high pressure hydraulic fluid. Use cardboard or paper to find hydraulic leaks. Hydraulic fluid escaping under pressure can penetrate the skin and cause injury. Fluid accidentally injected into the skin must be surgically removed within a few hours by a doctor or gangrene may occur.
27. Before any hydraulic system maintenance, stop the engine and lower the cutting units to the ground so all pressure is relieved.
28. To reduce potential fire hazard, keep engine area free of excessive grease, grass, leaves and dirt. Clean protective screen on back of engine frequently. Do not use flammable solvents for cleaning parts. Do not use diesel fuel, kerosene or gasoline.
29. Wear safety glasses, goggles or a face shield to prevent possible eye injury when using compressed air for cleaning or drying components.
30. Do not overspeed the engine by changing governor setting. Maximum engine speed (engine coupled to hydraulic pump) is 2500 rpm \pm 100 rpm. To assure safety and accuracy, have an Authorized Toro Distributor check maximum engine speed.
31. Shut engine off before checking or adding oil to the engine crankcase.
32. Toro recommends that two people be used to back-lap reels. Each person has specific duties and you must communicate with one another.
33. Failure to follow proper procedures when mounting a tire on a wheel or rim can produce an explosion which may result in serious injury. Do not attempt to mount a tire unless you have the proper equipment and experience to perform the job. Have it done by your Toro Distributor or a qualified tire service.
34. Do not charge a frozen battery because it can explode and cause injury. Let the battery warm to 60° F (15.5° C) before connecting to a charger. Charge the battery in a well-ventilated place so that gases produced while charging can dissipate. Since the gases are explosive, keep open flame and electrical spark away from the battery; do not smoke. Nausea may result if the gases are inhaled. Unplug the charger from the electrical outlet before connecting or disconnecting the charger leads from the battery posts.
35. When changing attachments or performing other service, use the correct blocks and hoists. Always use jackstands to safely support the machine when it is raised by a jack or hoist.
36. For optimum performance and safety, use genuine Toro replacement parts and accessories. Replacement parts and accessories made by other manufacturers could be dangerous and may void the product warranty of The Toro Company.



Product Records and Manuals

Table of Contents

PRODUCT RECORDS	1	TORQUE SPECIFICATIONS	3
EQUIVALENTS AND CONVERSIONS	2	Capscrew Markings and Torque Values – U.S. . .	3
Decimal and Millimeter Equivalents	2	Capscrew Markings and Torque Values – Metric .	3
U.S. to Metric Conversions	2	OPERATION AND SERVICE HISTORY REPORT .	5

Product Records

Record information about your Reelmaster 450–D on the OPERATION AND SERVICE HISTORY REPORT form. Use this information when referring to your machine.

Insert Operator’s Manuals and Parts Catalogs for your Reelmaster 450–D at the end of this section.

Equivalents and Conversions

Decimal and Millimeter Equivalents

Fractions	Decimals	mm	Fractions	Decimals	mm	
	1/64	0.015625	- 0.397	33/64	0.515625	- 13.097
	1/32	0.03125	- 0.794	17/32	0.53125	- 13.494
	3/64	0.046875	- 1.191	35/64	0.546875	- 13.891
1/16	0.0625	- 1.588	9/16	0.5625	- 14.288	
	5/64	0.078125	- 1.984	37/64	0.578125	- 14.684
	3/32	0.09375	- 2.381	19/32	0.59375	- 15.081
	7/64	0.109275	- 2.778	39/64	0.609375	- 15.478
1/8	0.1250	- 3.175	5/8	0.6250	- 15.875	
	9/64	0.140625	- 3.572	41/64	0.640625	- 16.272
	5/32	0.15625	- 3.969	21/32	0.65625	- 16.669
	11/64	0.171875	- 4.366	43/64	0.671875	- 17.066
3/16	0.1875	- 4.762	11/16	0.6875	- 17.462	
	13/64	0.203125	- 5.159	45/64	0.703125	- 17.859
	7/32	0.21875	- 5.556	23/32	0.71875	- 18.256
	15/64	0.234375	- 5.953	47/64	0.734375	- 18.653
1/4	0.2500	- 6.350	3/4	0.7500	- 19.050	
	17/64	0.265625	- 6.747	49/64	0.765625	- 19.447
	9/32	0.28125	- 7.144	25/32	0.78125	- 19.844
	19/64	0.296875	- 7.541	51/64	0.796875	- 20.241
5/16	0.3125	- 7.541	13/16	0.8125	- 20.638	
	21/64	0.328125	- 8.334	53/64	0.828125	- 21.034
	11/32	0.34375	- 8.731	27/32	0.84375	- 21.431
	23/64	0.359375	- 9.128	55/64	0.859375	- 21.828
3/8	0.3750	- 9.525	7/8	0.8750	- 22.225	
	25/64	0.390625	- 9.922	57/64	0.890625	- 22.622
	13/32	0.40625	- 10.319	29/32	0.90625	- 23.019
	27/64	0.421875	- 10.716	59/64	0.921875	- 23.416
7/16	0.4375	- 11.112	15/16	0.9375	- 23.812	
	29/64	0.453125	- 11.509	61/64	0.953125	- 24.209
	15/32	0.46875	- 11.906	31/32	0.96875	- 24.606
	31/64	0.484375	- 12.303	63/64	0.984375	- 25.003
1/2	0.5000	- 12.700	1	1.000	- 25.400	
	1 mm = 0.03937 in.			0.001 in. = 0.0254 mm		

U.S to Metric Conversions

	To Convert	Into	Multiply By
Linear Measurement	Miles	Kilometers	1.609
	Yards	Meters	0.9144
	Feet	Meters	0.3048
	Feet	Centimeters	30.48
	Inches	Meters	0.0254
	Inches	Centimeters	2.54
	Inches	Millimeters	25.4
Area	Square Miles	Square Kilometers	2.59
	Square Feet	Square Meters	0.0929
	Square Inches	Square Centimeters	6.452
	Acre	Hectare	0.4047
Volume	Cubic Yards	Cubic Meters	0.7646
	Cubic Feet	Cubic Meters	0.02832
	Cubic Inches	Cubic Centimeters	16.39
Weight	Tons (Short)	Metric Tons	0.9078
	Pounds	Kilograms	0.4536
	Ounces (Avdp.)	Grams	28.3495
Pressure	Pounds/Sq. In.	Kilopascal	6.895
Work	Foot-pounds	Newton-Meters	1.356
	Foot-pounds	Kilogram-Meters	0.1383
	Inch-pounds	Kilogram-Centimeters	1.152144
Liquid Volume	Quarts	Liters	0.9463
	Gallons	Liters	3.785
Liquid Flow	Gallons/Minute	Liters/Minute	3.785
Temperature	Fahrenheit	Celsius	1. Subtract 32°
			2. Multiply by 5/9

Torque Specifications

Use these torque values when specific torque values are not given. DO NOT use these values in place of specified values.

The torque values listed below are for lubricated threads. Plated threads are considered to be lubricated.

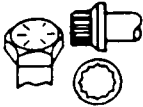
Capscrew Markings and Torque Values - U.S. Customary								
SAE Grade Number	5				8			
Capscrew Head Markings								
Capscrew Body Size	Capscrew Torque - Grade 5				Capscrew Torque - Grade 8			
	Cast Iron		Aluminum		Cast Iron		Aluminum	
	ft-lb	Nm	ft-lb	Nm	ft-lb	Nm	ft-lb	Nm
1/4-20 -28	7 9	9 12	6 7	8 9	11 13	15 18	9 10	12 14
5/16-18 -24	15 17	20 23	12 14	16 19	22 24	30 33	18 19	24 25
3/8-16 -24	30 30	40 40	20 25	25 35	40 45	55 60	30 35	40 45
7/16-14 -20	45 50	60 65	35 40	45 55	65 70	90 95	50 55	65 75
1/2-13 -20	70 75	95 100	55 60	75 80	95 110	130 150	75 90	100 120
9/16-12 -18	100 110	135 150	80 85	110 115	140 155	190 210	110 125	150 170
5/8-11 -18	135 155	180 210	110 120	150 160	190 215	255 290	150 170	205 230
3/4-10 -16	240 270	325 365	190 210	255 285	340 380	460 515	270 300	365 410
7/8-9 -14	360 390	490 530	280 310	380 420	550 610	745 825	440 490	600 660
1-8 -14	530 590	720 800	420 480	570 650	820 890	1100 1200	660 710	890 960

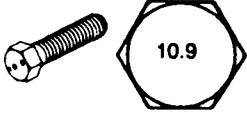
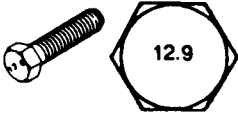
Capscrew Markings and Torque Values - Metric												
Commercial Steel Class 8.8			10.9				12.9					
Capscrew Head Markings												
Thread Diameter mm	Capscrew Torque - Class 8.8				Capscrew Torque - Class 10.9				Capscrew Torque - Class 12.9			
	Cast Iron		Aluminum		Cast Iron		Aluminum		Cast Iron		Aluminum	
	ft-lb	Nm	ft-lb	Nm	ft-lb	Nm	ft-lb	Nm	ft-lb	Nm	ft-lb	Nm
6	5	9	4	7	9	14	7	11	9	14	7	11
7	9	14	7	11	14	18	11	14	18	23	14	18
8	18	25	14	18	23	32	18	25	27	36	21	28
10	30	40	25	30	45	60	35	45	50	70	40	55
12	55	70	40	55	75	105	60	80	95	125	75	100
14	85	115	65	90	120	160	95	125	145	195	110	150
16	130	180	100	140	175	240	135	190	210	290	165	220
18	170	230	135	180	240	320	185	250	290	400	230	310

This page is blank.



EQUIPMENT OPERATION AND SERVICE HISTORY REPORT
for
REELMASTER® 450-D and 4500-D

TORO Model and Serial Number: _____-_____

Engine Numbers: _____

Transmission Numbers: _____

Drive Axle(s) Numbers: _____

Date Purchased: _____ Warranty Expires _____

Purchased From: _____

Contacts: Parts _____ Phone _____

 Service _____ Phone _____

 Sales _____ Phone _____

REELMASTER 450-D and 4500-D Maintenance Schedule

Minimum Recommended Maintenance Intervals

Maintenance Procedure	Maintenance Interval & Service				
	Every 50hrs	Every 100hrs	Every 200hrs	Every 400hrs	Every 800hrs
Lubricate Reel Control Valve Grease Fitting Lubricate Reel Speed Control Valve with Oil Lubricate all Grease Fittings Check Battery Condition and Connections	<i>A Level Service</i>				
‡ Change Engine Oil and Filter Drain Water from Hydraulic Tank † Check Fan and Alternator Belt Inspect Cooling System Hoses		<i>B Level Service</i>			
Service Air Cleaner Filter Element Inspect Cutting Unit Reel Drive Belts † Torque Wheel Lug Nuts			<i>C Level Service</i>		
Replace Fuel Filter Inspect Fuel Lines and Connections ‡ Torque Cylinder Head and Adjust Valves ‡ Check Engine RPM (idle and full throttle)				<i>D Level Service</i>	
Drain and Clean Fuel Tank ‡ Replace Hydraulic Oil Filter Replace Hydraulic Tank Breather ‡ Change Front Planetary Gear Lube Pack Rear Axle Bearings (2wd) Check Rear Wheel Toe-In					<i>E Level Service</i>
† Initial break in at 10 hours ‡ Initial break in at 50 hours					
Replace all Moving Hoses Replace Safety Switches Cooling System – Flush / Replace Fluid Change Hydraulic Oil			<p style="text-align: center;">Annual Recommendations: <i>Items listed are recommended every 1500 hours or 2 years, whichever occurs first.</i></p>		

REELMASTER 450–D and 4500–D Daily Maintenance Check List

Daily Maintenance: (duplicate this page for routine use)

Check proper section of Operator’s Manual for fluid specifications

Maintenance Check Item ➡	Daily Maintenance Check For Week Of						
	MON	TUES	WED	THURS	FRI	SAT	SUN
✓ Safety Interlock Operation							
✓ Parking Brake Operation							
✓ Engine Oil Level							
✓ Fuel Level							
✓ Cooling System Fluid Level							
Drain Water/Fuel Separator							
✓ Dust Cup and Baffle (Air Filter)							
✓ Radiator & Screen for Debris ¹							
Clean Traction Pedal Lockout							
✓ Unusual Engine Noises ²							
✓ Unusual Operating Noises							
✓ Hydraulic System Oil Level							
✓ Hydraulic Hoses for Damage							
✓ Fluid Leaks							
✓ Tire Pressure							
✓ Instrument Operation							
✓ Warning Lamps Operation							
✓ Reel-to-Bedknife Adjustment							
✓ Height-of-Cut Adjustment							
Lubricate All Grease Fittings ³							
Touch-up Damaged Paint							

¹= Use only low pressure compressed air for debris removal. **Do not use water.**

²= Check glow plug and injector nozzles, if hard starting, excess smoke or rough running is noted.

³= Immediately after every washing, regardless of the interval listed.

Notation for areas of concern: Inspection performed by _____

Item	Date	Information
1		
2		
3		
4		
5		
6		
7		
8		

REELMASTER® 450-D and 4500-D Supervisor Maintenance Work Order

Date: _____

(duplicate this page for routine use)

Unit Designation:	TORO I.D. #: _____
Hours:	Service to perform (circle): A B C D E Other
Technician:	_____

Remarks: _____

A -Service (every 50 hours)

- Lubricate Reel Control Valve Fitting
- Lubricate Reel Speed Valve with Oil
- Lubricate all Grease Fittings
- Check Battery Condition/Connections
- _____
- _____
- _____
- _____
- _____

B -Service (every 100 hours)

- Change Engine Oil and Filter
- Drain water from Hydraulic Tank
- Check Engine Fan and Alternator Belt
- Inspect Cooling System Hoses
- A-Service** required
- _____
- _____
- _____
- _____

C -Service (every 200 hours)

- Service Air Cleaner Filter Element
- Inspect Cutting Unit Reel Drive Belts
- Torque Wheel Lug Nuts
- A and B Service** required
- _____
- _____
- _____
- _____
- _____

D -Service (every 400 hours)

- Replace Fuel Filter
- Inspect Fuel Lines and Connections
- Torque Cylinder Head/Adjust Valves
- Check Engine RPM (Idle/Full Throttle)
- A, B, and C Service** required
- _____
- _____
- _____
- _____

E -Service (every 800 hours)

- Drain and Clean Fuel Tank
- Replace Hydraulic Oil Filter
- Replace Hydraulic Tank Breather
- Change Front Planetary Gear Lube
- Pack Rear Axle Bearings (2WD)
- Check Rear Wheel Toe-in
- A, B, C, and D Service** required
- _____
- _____

Other - Annual Service and Specials

- Replace Moving Hoses
- Replace Safety Switches
- Coolant System - Flush/Replace Fluid
- Change Hydraulic Oil
- _____
- _____
- _____
- _____
- _____



Table of Contents

SPECIFICATIONS 1
MITSUBISHI 4DQ5 DIESEL ENGINE
SERVICE MANUAL
FUEL SYSTEM SUPPLEMENT,
MITSUBISHI 4DQ5 DIESEL ENGINE

Specifications

Engine: Mitsubishi model 4DQ5, four-cycle, four cylinder, 127 cu-in. displacement, water cooled diesel engine. Rated 40 hp @ 2300 rpm, 21:1 compression ratio.

Governor Settings: Low idle - 1200 rpm, high idle - 2500 rpm.

Injection Timing: 24° BTDC.

Engine Oil: All temperatures use SAE 10W30 SF, CD.

Oil Capacity: 6.9 qt. (6.5 L) with filter.

Fuel System: Capacity is 15.3 gal. (58 L). #2 diesel fuel.

Cooling System: Capacity is 2.6 gal. (10 L). 50/50 mixture of ethylene glycol antifreeze and water.

Service Manual

Mitsubishi 4DQ5 Diesel Engine

Reelmaster[®] 350-D

Reelmaster[®] 450-D

(For Reelmaster 450-D, use with
Service Manual Supplement, Fuel System)



INDEX

GENERAL	1
MAJOR DATA AND SPECIFICATIONS	5
DISASSEMBLY	8
INSPECTION AND REPAIR	16
REASSEMBLY	37
LUBRICATING SYSTEM	49
COOLING SYSTEM	52
FUEL SYSTEM	56
ELECTRICAL SYSTEM	71
MAINTENANCE STANDARDS	89
SEALANT APPLICATION DATA	102
TIGHTENING TORQUE	103
SPECIAL SERVICE TOOLS	105
TROUBLESHOOTING CHART	110

WARNING! Do not use starting fluids, such as ether, as a starting aid; the potential for a dangerous explosion will result.

Visit an authorized Nippondenso service dealer for repair work on the fuel injection pump - especially during the warranty period. Repairs made by non-authorized dealers could void the pump's warranty. Also, contact the Nippon-denso service dealer BEFORE removing the pump from the engine.

The terminology used for "horsepower" in this book is PS.
PS = 1.014 x HP

GENERAL

1. Major component parts

1-1 Left-hand side view

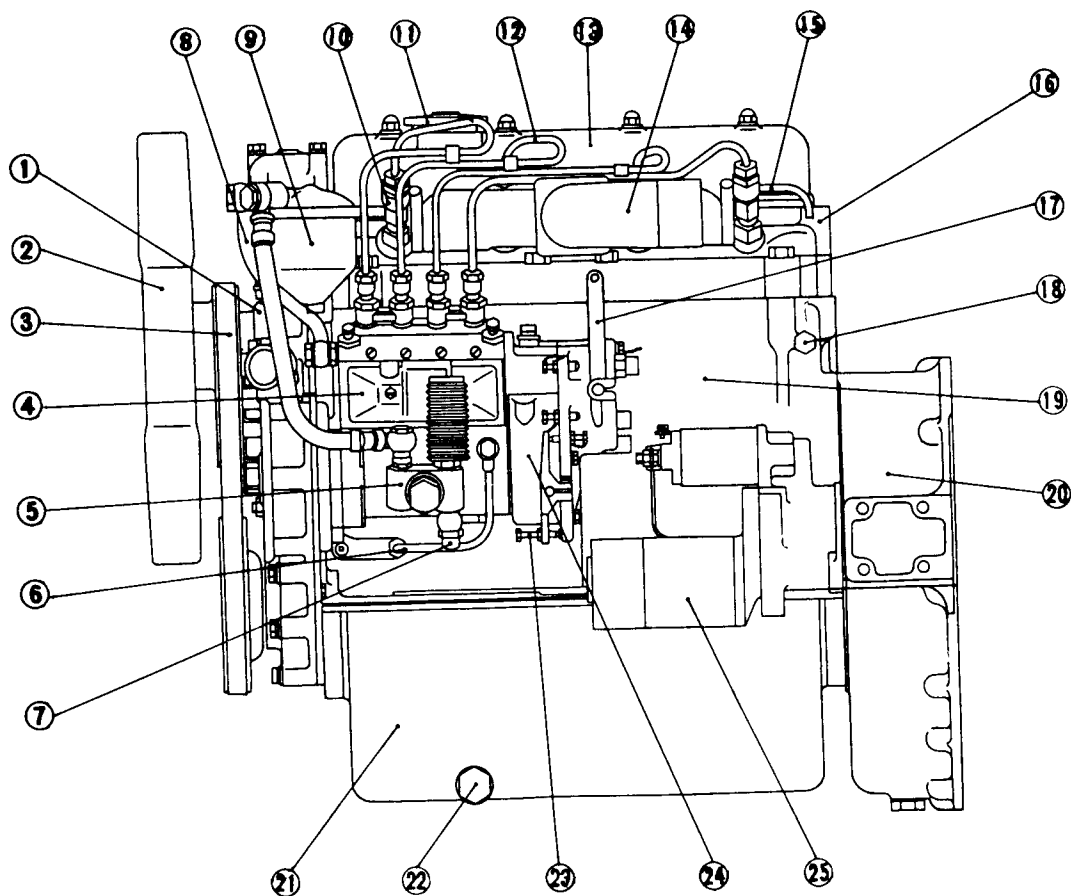

- 1-Water pump
- 2-Fan
- 3-Fan belt
- 4-Fuel injection pump
- 5-Fuel feed pump
- 6-Oil pipe
- 7-Fuel inlet connector
- 8-Fuel feed pipe
- 9-Fuel filter

- 10-Fuel injection nozzle
- 11-Oil filler cap
- 12-Fuel injection pipe
- 13-Rocker cover
- 14-Intake manifold
- 15-Fuel leak-off pipe
- 16-Cylinder head
- 17-Adjusting lever
- 18-Hanger

- 19-Crankcase
- 20-Flywheel housing
- 21-Oil pan
- 22-Drain plug
- 23-Control rack stopper
- 24-Governor
- 25-Starter

402500

1-2 Right-hand side view

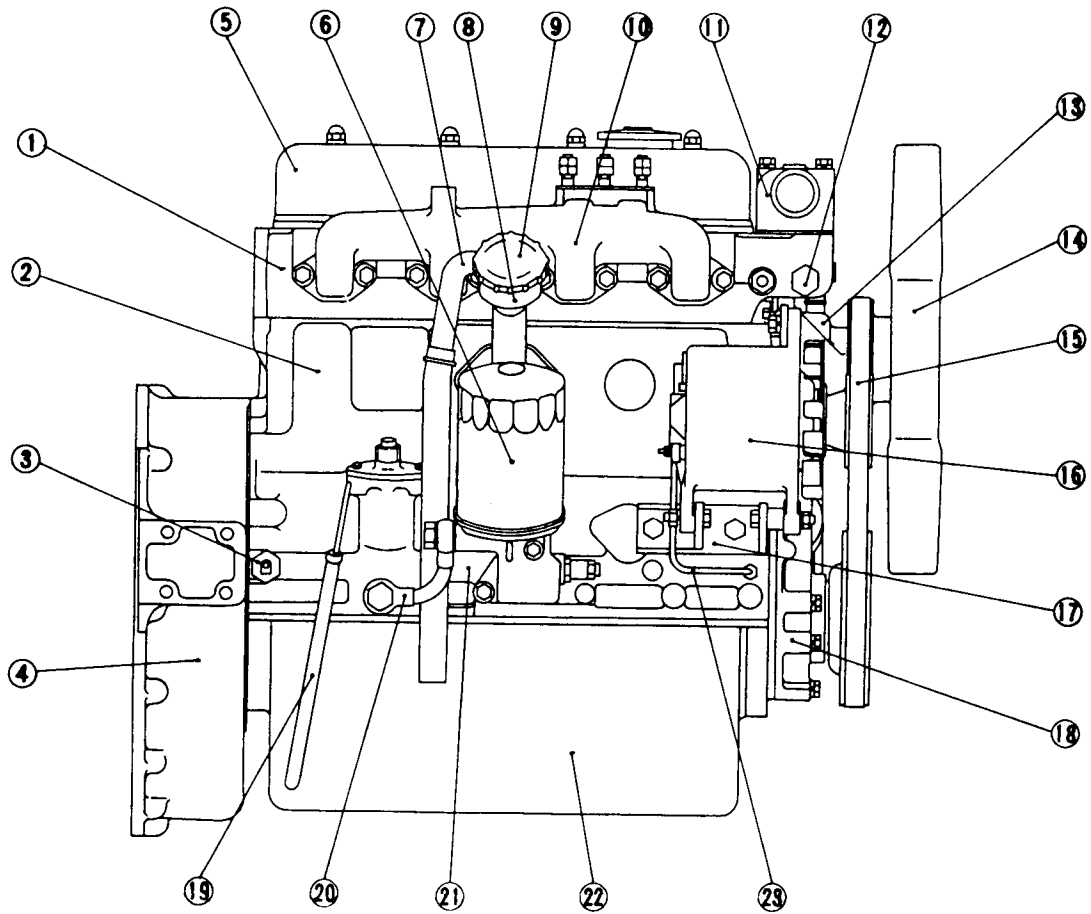

402501

- | | | |
|--------------------|---------------------|----------------------------|
| 1-Cylinder head | 9-Oil filler cap | 17-Alternator bracket |
| 2-Crankcase | 10-Exhaust manifold | 18-Timing gear case |
| 3-Indicator switch | 11-Elbow | 19-Oil level gauge |
| 4-Flywheel housing | 12-Screw plug | 20-Oil pipe |
| 5-Rocker cover | 13-Water pump | 21-Oil bypass alarm switch |
| 6-Oil filter | 14-Fan | 22-Oil pan |
| 7-Breather | 15-Fan belt | 23-Oil pipe |
| 8-Oil filler | 16-Alternator | |

1-3 Longitudinal sectional view

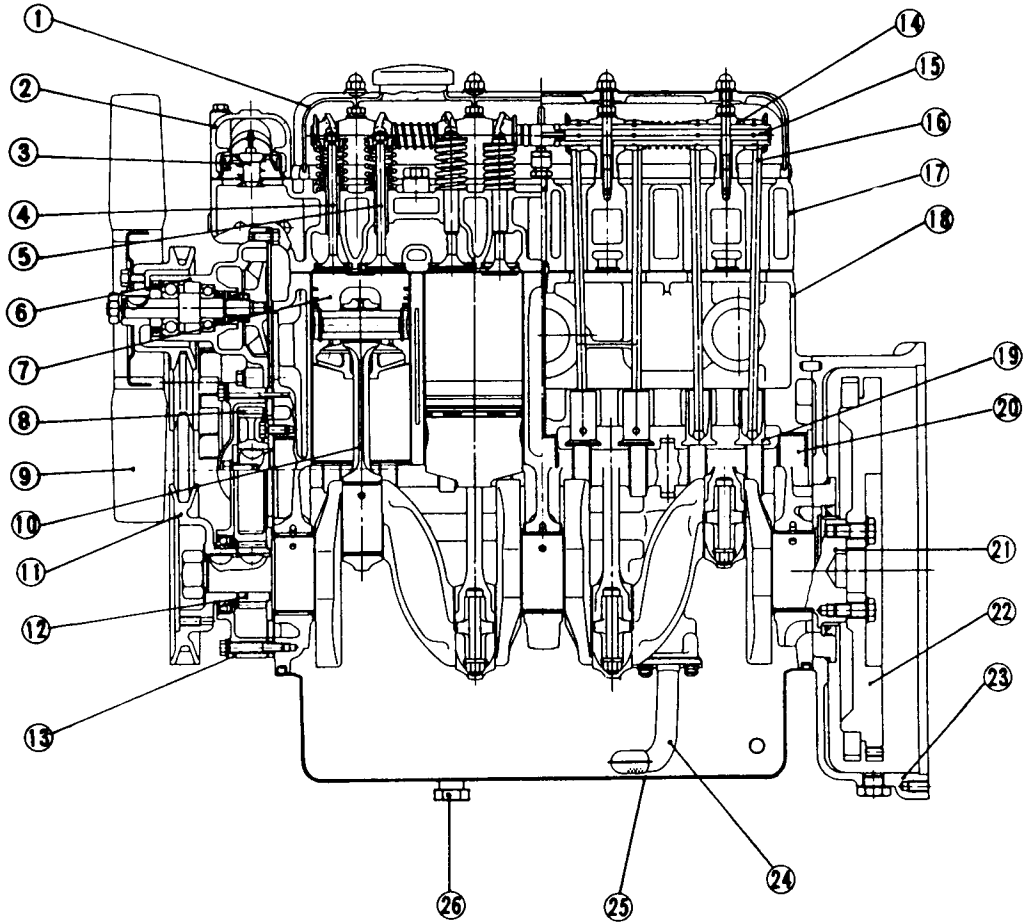

402502

- 1-Rocker cover
- 2-Thermostat case
- 3-Thermostat
- 4-Exhaust valve
- 5-Intake valve
- 6-Water pump
- 7-Piston
- 8-Camshaft gear
- 9-Fan

- 10-Connecting rod
- 11-Crankshaft pulley
- 12-Crankshaft gear
- 13-Timing gear case
- 14-Rocker shaft bracket
- 15-Rocker shaft
- 16-Valve push rod
- 17-Cylinder head
- 18-Crankcase

- 19-Tappet
- 20-Camshaft
- 21-Crankshaft
- 22-Flywheel
- 23-Flywheel housing
- 24-Oil strainer
- 25-Oil pan
- 26-Drain plug

1-4 Transverse sectional view

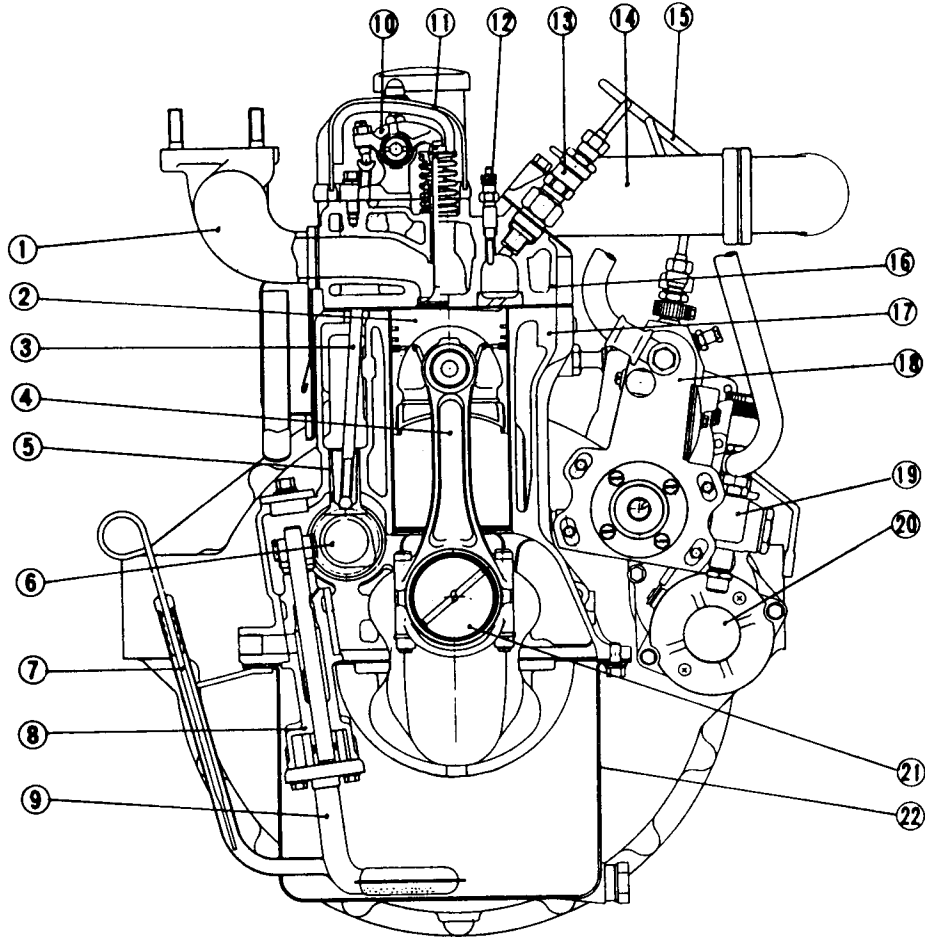

- 1-Exhaust manifold
- 2-Piston
- 3-Valve push rod
- 4-Connecting rod
- 5-Tappet
- 6-Camshaft
- 7-Oil level gauge
- 8-Oil pump

- 9-Oil strainer
- 10-Rocker arm
- 11-Rocker cover
- 12-Glow plug
- 13-Fuel injection nozzle
- 14-Intake manifold
- 15-Fuel injection pipe
- 16-Cylinder head

- 17-Crankcase
- 18-Fuel injection pump
- 19-Fuel feed pump
- 20-Starter
- 21-Crankshaft
- 22-Oil pan

402503

MAJOR DATA AND SPECIFICATIONS

Engine model			4DQ5	
General	Type		Water-cooled, 4-stroke, swirl-combustion chamber type diesel	
	No. of cylinders-arrangement		4-in line	
	Bore x stroke	mm (in.)	84 x 94 (3.307 x 3.701)	
	Piston displacement	cc (cu in.)	2084 (127.1)	
	Compression ratio		21 : 1	
	Compression pressure	kg/cm ² (psi)	26 (369.7), min (at 150 ~ 200 rpm)	
	Firing order		1 - 3 - 4 - 2	
	Direction of rotation		Counterclockwise as viewed from flywheel side	
	Burns (fuel)		Grade No. 2D diesel fuel (ASTM specification)	
	Engine oil		Class-CC or better (API service classification)	
Dimensions	Overall length		717.5 (28-1/4)	
	Overall width		562 (22-1/8)	
	Overall height		629.5 (24-3/4)	
	Weight, dry	kg (lb)	200 (441)	
	Cylinder sleeves		Dry type made of special cast iron or integral water-jacket type	
No. of piston rings	Compression rings		2	
	Oil ring		1 (w/spring expander)	
	Valve arrangement		Overhead	
Valve timing	Intake valves	Open at:	30° BTDC	
		Close at:	50° ABDC	
	Exhaust valves	Open at:	74° BBDC	
		Close at:	30° ATDC	
	Valve clearance (both intake and exhaust valves) (cold)	mm (in.)	0.25 (0.0098)	
	Starter		Electric	
Fuel system	Fuel feed pump	Model		ND-EP/KS22A
		Cam lift	mm (in.)	6 (0.24)
	Fuel injection pump	Model		PES4A65B
		Plunger diam	mm (in.)	6.5 (0.256)
		Plunger lead		Right
		Cam lift	mm (in.)	8 (0.31)
	Governor	Model		RUV (for prime power)
		Type		Centrifugal flyweight, all-speed
	Fuel injection nozzles	Type		Throttle
		Type of nozzle holders		Bosch CA17SD

Engine model			4DQ5	
Fuel system	Fuel injection nozzles	Type of nozzle tips		Bosch ND-DN0SD ₂₁
		Spray hole diam	mm (in.)	1 (0.04)
		Spray angle		0°
		Injection pressure	kg/cm ² (psi)	120 ⁺¹⁰ / ₀ (1706 ⁺¹⁴² / ₀)
Fuel filter			Paper-element type	
Lubrication system	Oil pump	Type		Trochoid
		Speed ratio to crankshaft		1/2
		Capacity at oil temp. 50 ± 5°C (122 ± 9°F); pressure 3 kg/cm ² (42.7 psi)	liter (cu in.)/ min/rpm	8.37 (510.8), min/1000 (pump rpm)
	Oil pressure	At duty run		3 ~ 4 (42.7 ~ 56.9)
		At idling		1 ~ 2 (14.2 ~ 28.4)
	Oil filter			Paper-element type
	Relief valve	Type		Piston-valve
		Valve opening pressure	kg/cm ² (psi)	3 ± 0.2 (42.7 ± 2.8)
	Refill capacity	Oil pan	liter (U.S. gal)	6.5 (1.7)
		Oil filter		0.7 (0.18)
Oil bypass valve	Type		Piston-valve	
	Valve opening pressure	kg/cm ² (psi)	0.8 ~ 1.2 (11.4 ~ 17.1)	
Cooling system	Water pump	Type		Centrifugal type
		Speed ratio to crankshaft		1.3
		Capacity	liter (cu in.)/ min/rpm	105 (6408)/3900 (pump rpm)
	Thermostat	Type		Wax
		Valve opening temperature		76.5 ± 2°C (169.7 ± 3.6°F)
		Valve lift temperature		90 ± 2°C (194 ± 3.6°F)
	Fan	Type		Circular-arc pusher type
		No. of blades		6
		Outside diameter	mm (in.)	380 (15)
		Ratio to crankshaft speed		1.3
	Drive belt	Type		Low-edge cog B
		No. of belts		1
	Refill capacity (engine water jacket)		liter (U.S. gal)	4.5 (1.2)

Engine model		4DQ5			
Electrical equipment	Working voltage		volt	12	
	Polarity		Negative (-) ground		
	Glow plugs	Type		Sheathed	
		Rated voltage – current		volt – ampere	10.5 – 8.3
		Resistance at normal temperature		ohm	1.26
	Starter	Model		M002T54172	
		Type		Totally enclosed, drip-proof, pinion-shift type with overrunning clutch	
		Manufacturer		Mitsubishi-Electric	
		Voltage-output		volt – kilowatt	12 – 2
		No. of pinion teeth/ No. of ring gear teeth		11/121	
	Alternator	Model		A001T25070	
		Type		3-phase AC type	
		Voltage-output		volt – ampere	12 – 35
		Manufacturer		Mitsubishi-Electric	
		Rated speed		rpm	5000
		Working speed			1000 ~ 13500
		Speed ratio to crankshaft		1.68	
	Regulator	Type		IC type built in alternator	
Regulated voltage		volt	14.4 ± 0.3		

* Normal intake vacuum is 30.0 inches of water

* Normal exhaust backpressure is 2.0 inches of mercury

The engine identification number is on the exhaust manifold side of the engine, near the front, and cast into the block. The engine's serial number is stamped into the pad located directly below the engine's model number.

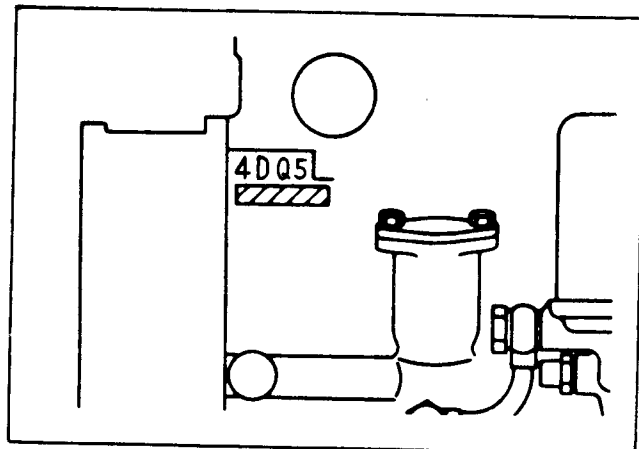

DISASSEMBLY

- (1) Drain the oil.
- (2) Remove the fan belt and alternator as follows:
 - (a) Loosen bolt (1) securing fan belt adjusting plate and alternator, and remove fan belt (2).
 - (b) Remove bolts (1) and (3) and remove alternator.

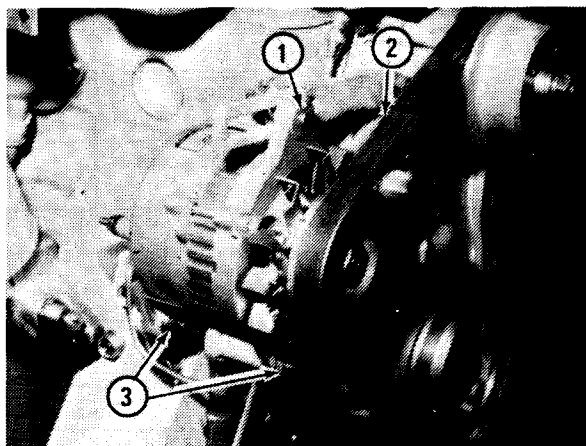

- (3) Remove the starter as follows:
 - (a) Loosen attaching nuts (1).
 - (b) Remove starter from rear plate.

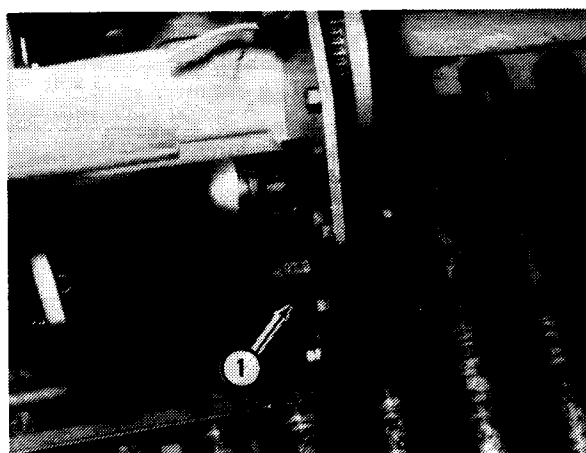

- (4) Remove the fuel filter as follows:
 - (a) Disconnect fuel feed pipes (1) (2).
 - (b) Loosen attaching bolts (3) and remove fuel filter (4).

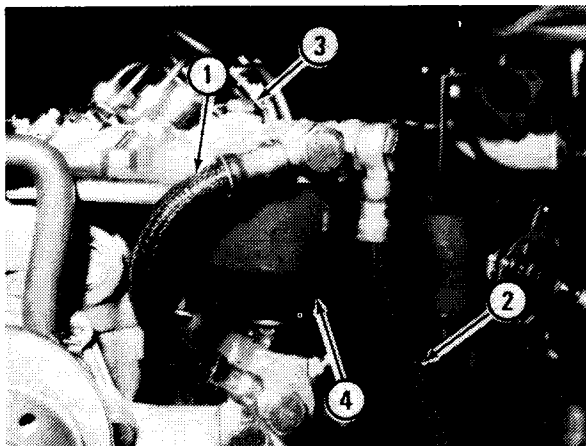

(5) Remove the injection pipes and injection nozzles as follows:

- (a) Loosen connectors (1) and disconnect injection pipes (2).
- (b) Remove fuel return pipe (3) by loosening union nut.
- (c) Loosen nuts (4) and remove fuel leak-off pipe (5).
- (d) Remove nozzle assemblies.

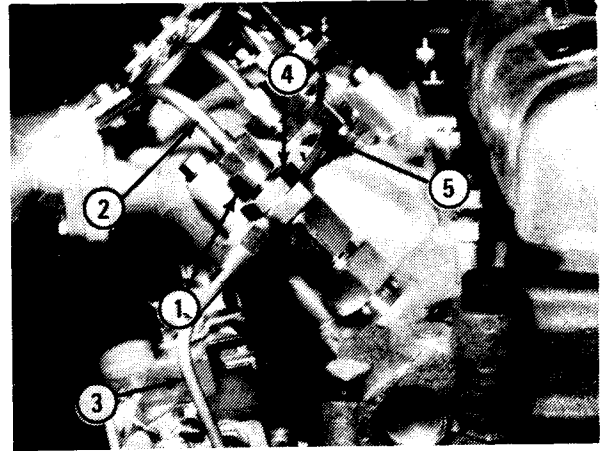

(6) Remove the lube oil pipe from injection pump.

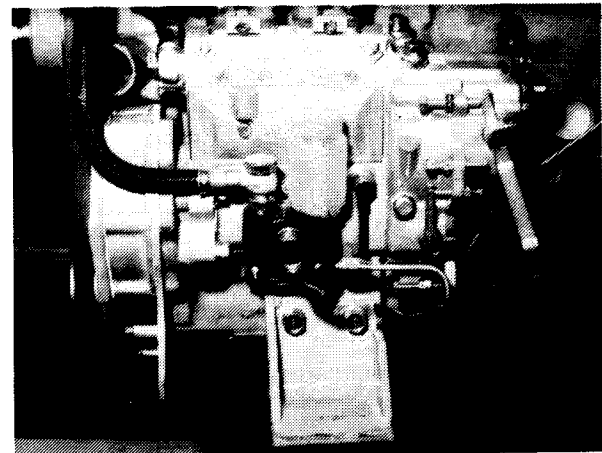

(7) Remove the water pump pulley and crankshaft pulley as follows:

- (a) Loosen water pump shaft nut (1) and remove water pump pulley (2).
- (b) Loosen crankshaft nut (3) and remove crankshaft pulley (4).

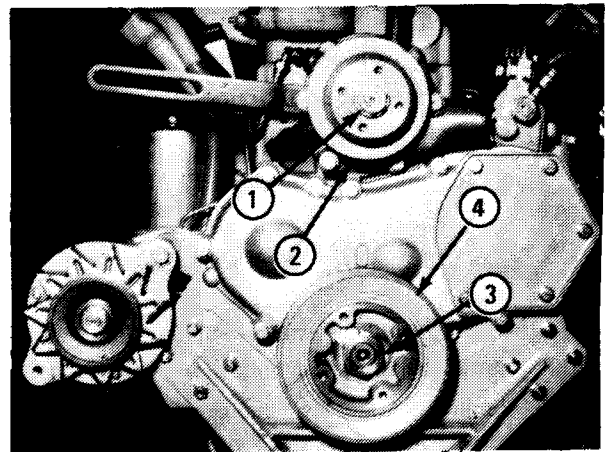

(8) Remove the timing gear case.

(9) Remove the rocker cover.

- (10) Disconnect the water pump bypass hose and oil pipe. To disconnect bypass hose, displace thermostat elbow and water pump clamp.

- (11) Remove the water pump as follows:
(a) Loosen attaching bolts (1).
(b) Remove water pump assembly (2).

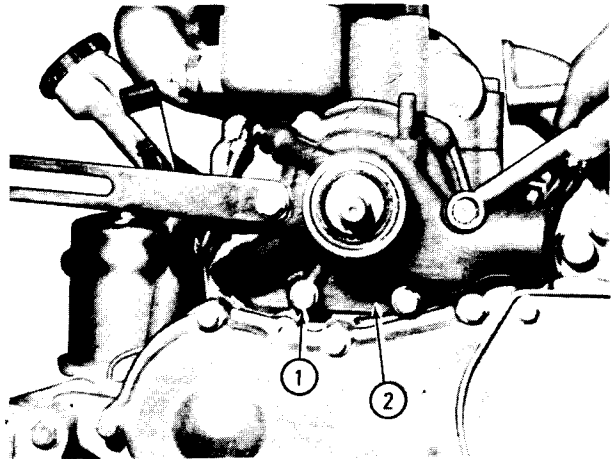

- (12) Remove the rocker shaft assembly as follows:
(a) Loosen union nut (1).
(b) Loosen short bolts (2) and long bolts (3).
(c) Remove rocker shaft assembly (4).
(d) Remove oil pipe (5) and "O" rings (2 pcs – to be replaced with new ones).
(e) Remove valve push rods and valve caps.
(f) Remove intake manifold.

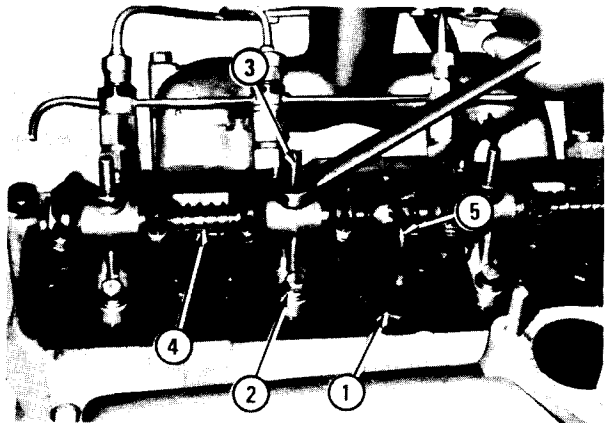

- (13) Remove the cylinder head assembly as follows:
(a) Loosen cylinder head bolts (1).
(b) Remove cylinder head and gasket.

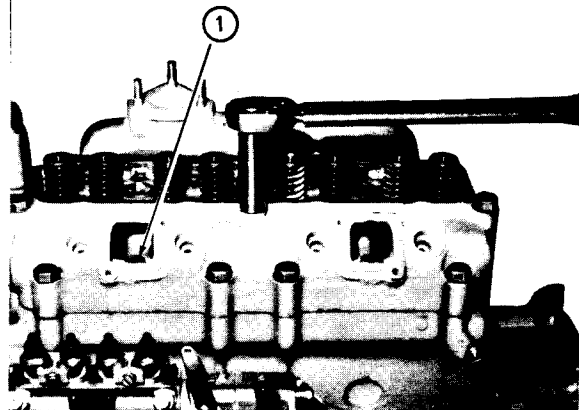

(14) Remove the oil pan and oil pump assembly as follows:

- (a) Loosen attaching bolts and remove oil pan (1) and gasket.
- (b) Loosen attaching bolts and remove oil pump (2) assembly.

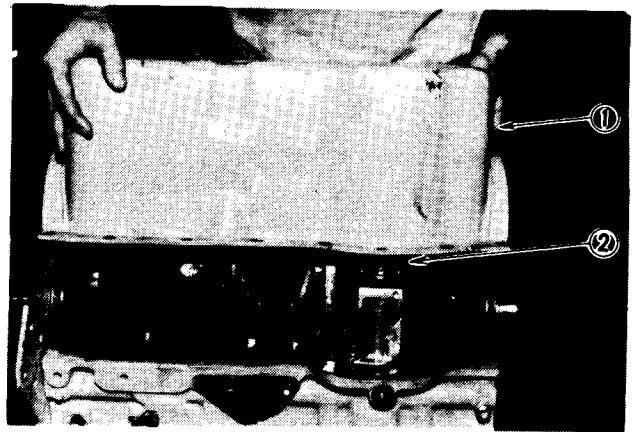

(15) Remove the timing gear train as follows:

- (a) Loosen idler gear bolt (1).
- (b) Remove thrust plate (2) and idler gear (3).
(Draw idler gear while twisting it in the direction of its helix.)
- (c) Loosen injection pump drive gear nut (4).
- (d) Remove injection pump drive gear (5).

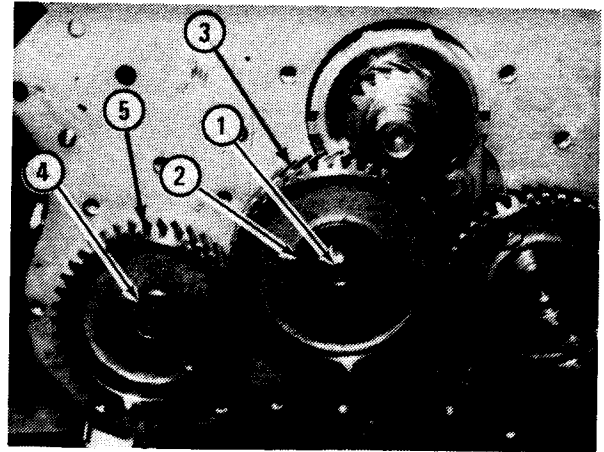

(16) Remove the camshaft assembly as follows:

Take out camshaft assembly (1) from crankcase.

NOTE

There are tappets in crankcase; this makes it necessary to turn crankcase upside down when removing camshaft assembly.

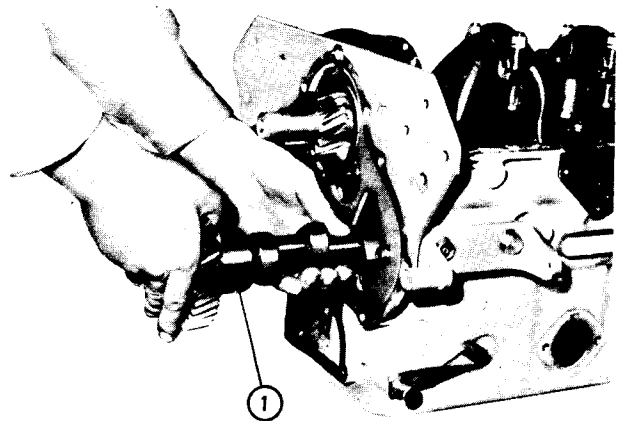

(17) Remove the front plate and injection pump assembly as follows:

- (a) Loosen attaching bolts (1).
- (b) Remove front plate and injection pump assembly.

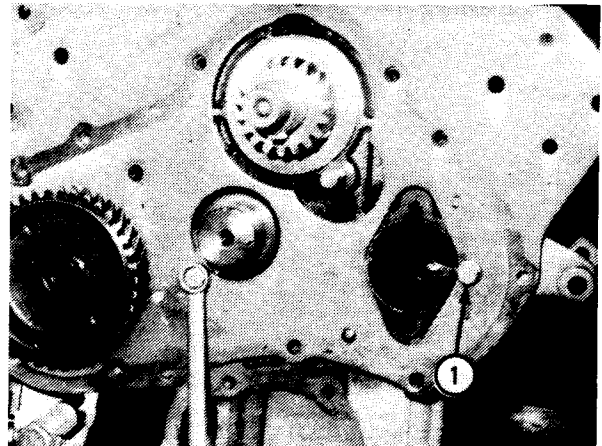

(18) Remove the flywheel and rear plate.

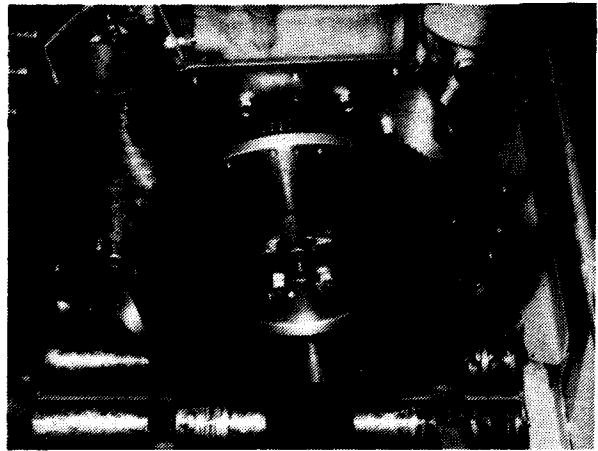

(19) Remove the connecting rod bearing caps and bearings (lower shells) by loosening attaching bolts.

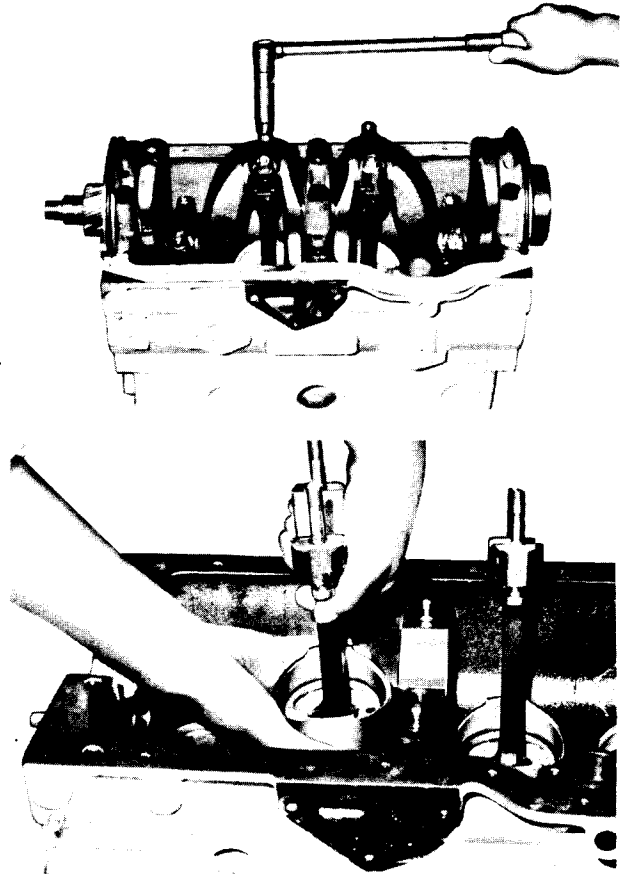

(20) Remove the connecting rods and pistons.

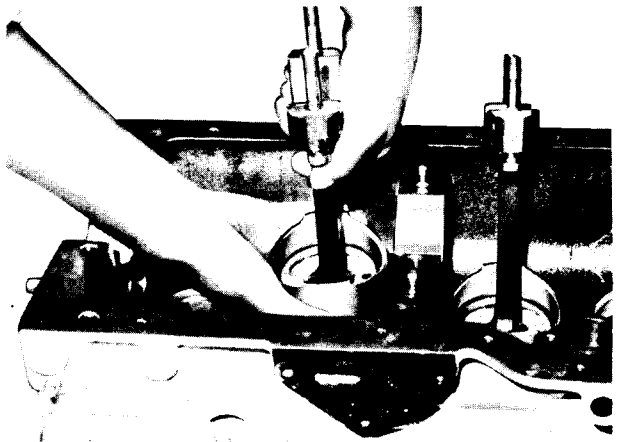

(21) Remove the main bearing caps by loosening attaching bolts.

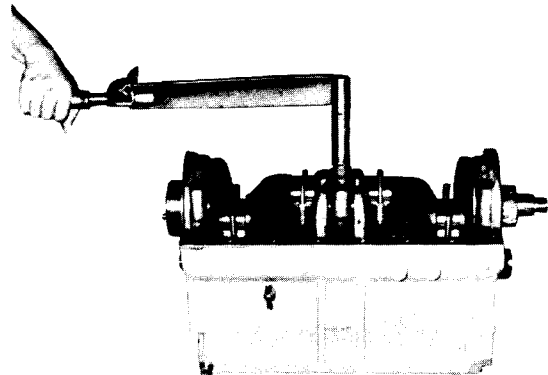

(22) Remove the crankshaft.

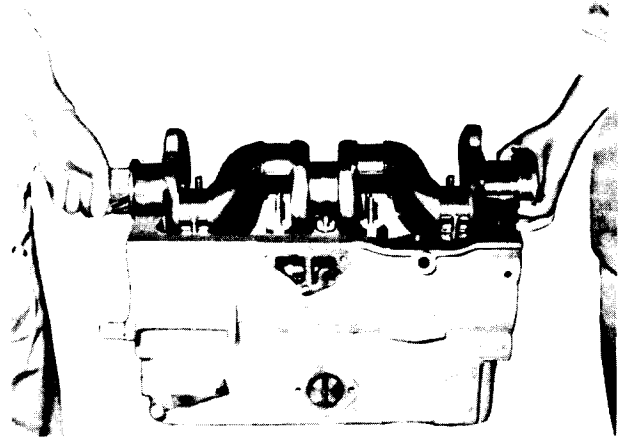

(23) Remove the main bearing shells.

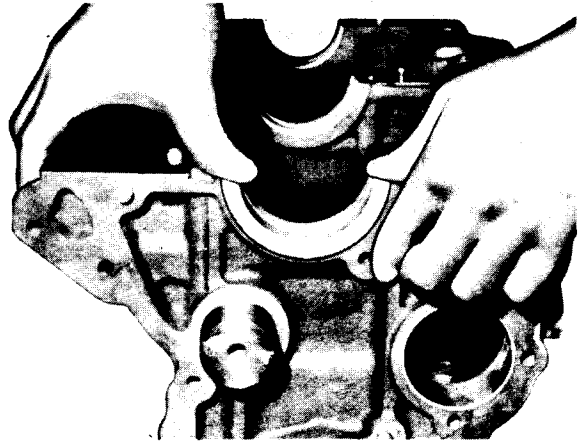

(24) Disassemble piston and connecting rod as follows:

- (a) Remove compression rings (1) and oil ring (2) by using piston ring tool (A).
- (b) Remove oil ring spring.

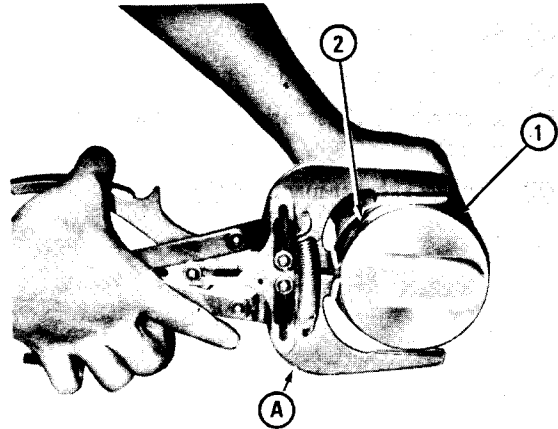

- (c) Remove snap rings (3) by using snap ring tool (B).

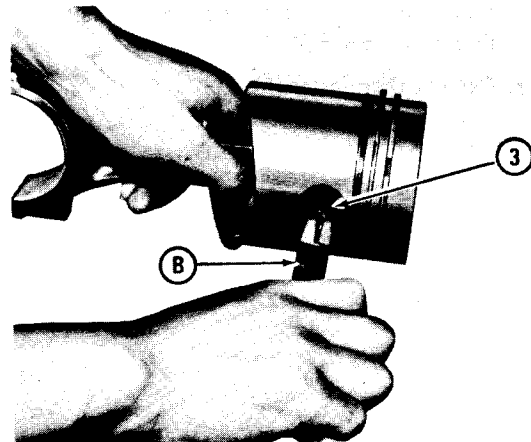

- (d) Remove piston pin (4) by using drift (C).
- (e) Remove piston pin bushing and connecting rod bearing (upper).

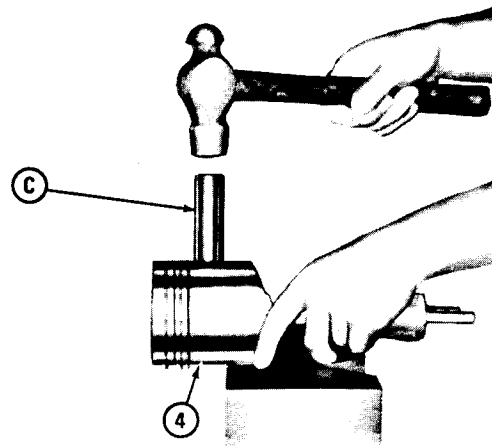

(25) Disassemble the rocker shaft assembly as follows:

- (a) Remove snap rings on both ends (1).
- (b) Remove rocker assembly (2).
- (c) Remove rocker bracket (3).
- (d) Remove rocker assembly (4).
- (e) Remove spring (5).

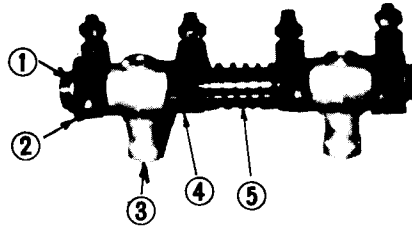

(26) Disassembly the cylinder head as follows:

- (a) Remove nozzle holders.
- (b) Remove glow plugs (1).
- (c) Loosen bolts (2) securing exhaust and intake manifolds.
- (d) Remove exhaust manifold (3).

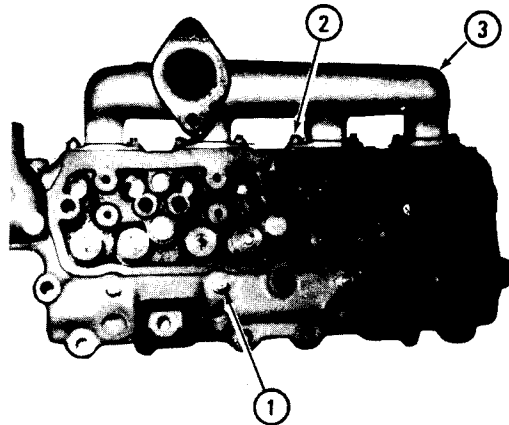

- (e) Loosen thermostat cover bolts and remove thermostat cover (4).
- (f) Remove thermostat (5).

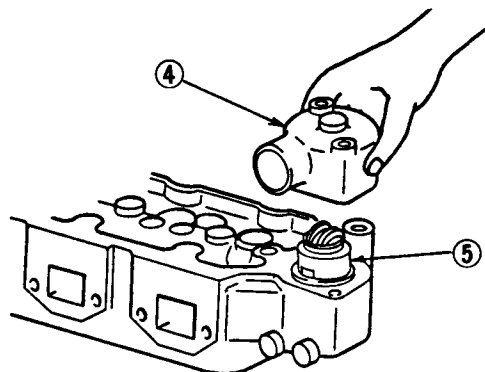

- (g) Remove valve cotters (6).
(Depress valve spring by valve lifter.)
- (h) Remove retainer (7).
- (i) Remove valve spring (8).
- (j) Take out valve (9).

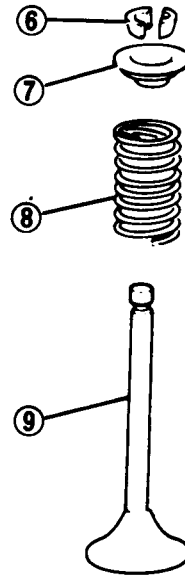

- (k) Remove valve guide by using valve guide remover (A).

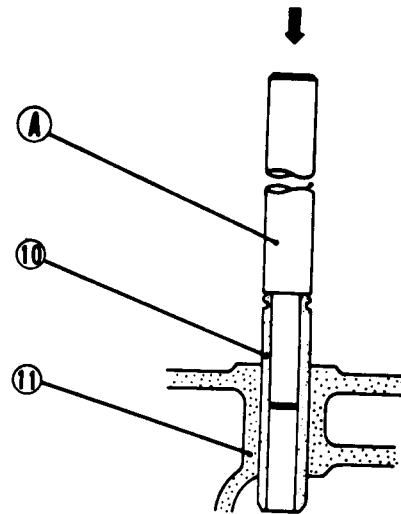

10-Valve guide
11-Cylinder head

A-Valve guide remover

INSPECTION AND REPAIR

Cylinder head

(1) Inspection

Check the gasketed surface of the cylinder head for flatness by using a straightedge and thickness gauge as in the case of checking the crankcase surfaces. This check is to be made with the precombustion chamber jets removed.

Use a surface grinder to reface the cylinder head, as necessary, to the specified flatness.

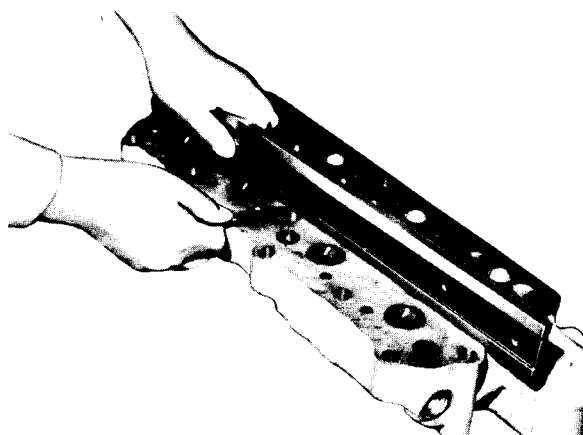

Specifications Unit: mm (in.)

Item	Standard	Repair limit
Warpage of gasketed surface of cylinder head	0.05, max (0.0020)	0.20 (0.0079)

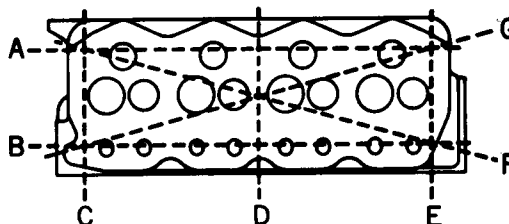

Checking cylinder head gasketed surface for flatness

(2) Precombustion chamber jet replacement

Do not remove the precombustion chamber jets unless their replacement is necessary. To remove the jet, as when cracks are noted in it, ease it out by driving with a flat-faced drift pin inserted through the glow plug hole, as shown.

Before installing the jet, wash the precombustion chamber cavity clean, and drive the jet into position, with its orifice pointing to the center of the cylinder. Calk one portion with a punch.

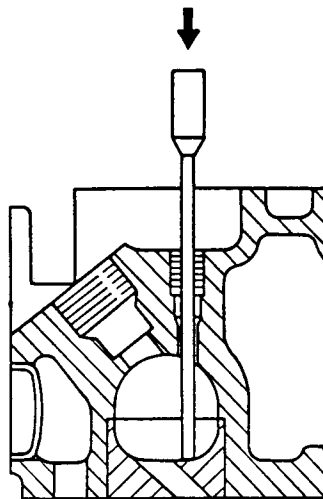

Removing precombustion chamber jet

Due to mechanical damage (eg. a loose screw in the combustion chamber that damages jet).

Cracks in the jet are permissible.

A-Intake port C-Jet
B-Exhaust port

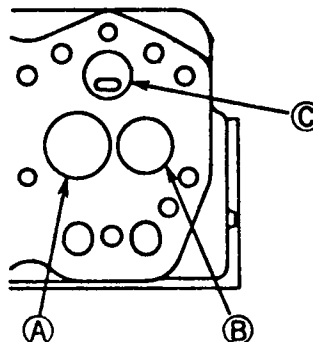

Direction of precombustion chamber jet orifice in installed state

Valve guides and valve seats

- (1) Check each valve for carboning, burning, wear or other defect on head; also check cap end and stem for cracks. Replace the valve if damaged.
- (2) Check each valve guide for wear. Remember, the guide wears down more rapidly at its both ends than at any other parts. Measure the inside diameter of the guide at its ends and at its middle part in two directions. Measure the outside diameter of each valve stem. If the measurement exceeds the repair limit in Table below, replace the valve guide.

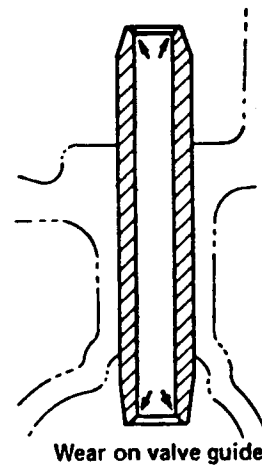

(3) Valve face and valve seat

Check valve face and valve seat for wear and contact. If valve face is found excessively worn, reface it by using a valve refacer. To reface the valve, proceed as follows:

NOTE:

Standard = size of part when new from the factory

Repair Limit = maximum size of a used part that may still be used or reworked.

Service Limit = size of the part that would require replacement of that part.

Specifications

Unit: mm (in.)

Item		Standard	Repair limit
Clearance of valve stem in valve guide	Intake	0.055 ~ 0.085 (0.00217 ~ 0.00335)	0.15 (0.0059)
	Exhaust	0.070 ~ 0.105 (0.00276 ~ 0.00413)	0.20 (0.0079)
Valve guide length outside hole		18 ± 0.3 (0.709 ± 0.012)	
Valve stem diameter	Intake	8 ^{-0.045} _{-0.060} (0.315 ^{-0.00177} _{-0.00236})	-0.10 (-0.0039)
	Exhaust	8 ^{-0.060} _{-0.080} (0.315 ^{-0.00236} _{-0.00315})	-0.15 (-0.0059)

Specifications

Unit: mm (in.)

Item		Nominal value	Standard	Repair limit	Service limit
Valve seat	Angle	30°			
	Sinkage	0.8 (0.031)	±0.2 (±0.008)	1.3 (0.051)	
	Width	1.4 (0.055)	±0.14 (±0.0055)	1.6 (0.063)	
Valve margin		1.7 (0.067)		Reface up to 1.2 (0.047)	

Valve refacer

- (a) Set a valve refacer to an angle of 45 degrees.
- (b) Grind the valve stock to a minimum and, if the margin is less than 1.2 mm (0.047 in.), replace the valve.

Valve seat cutter

Repair an excessively worn valve seat by using a valve seat grinder or valve seat cutter.

- (c) When using a valve seat cutter, exercise care so as to apply a uniform pressure to valve seat to prevent uneven cutting. After cutting, reface the seat by rotating the cutter with No. 400 sandpaper put between the cutter and seat.
- (d) If valve seat width is overcut, repair it using a 30-degree cutter. If valve seat width exceeds 1.6 mm (0.063 in.) due to wear, replace the seat. Also replace the seat when valve sinkage exceeds 1.3 mm (0.051 in.).

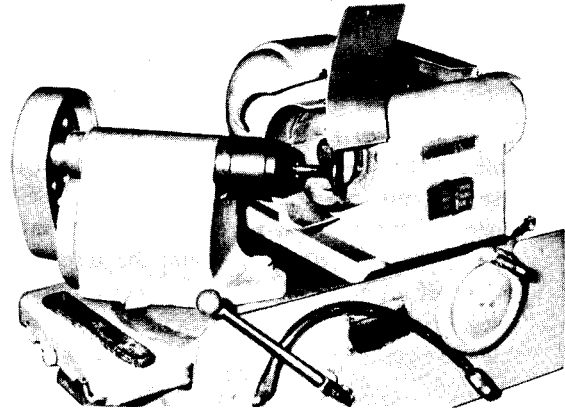

Valve seat installation

Chill the valve seat inserts in ether or alcohol containing dry ice. Heat the cylinder head to a temperature of 80°C to 100°C (176°F to 212°F). Press the inserts in the cylinder head by using the insert calking tools (30691-02700 for intake valve, 30691-02800 for exhaust valve). Leave the cylinder head and the inserts in the air until shrinkage-expansion fit is obtained between the two. Calk around the inserts with the insert calking tool to machine the seat width.

NOTE

The insert calking tool may be used both for pressing and calking the valve seat inserts by reversing the calking ring.

Valve springs

Inspect each spring for cracks, and check it for squareness, free length and as-installed length against these specifications:

Specifications		Unit: mm (in.)
Item	Standard	Repair limit
Valve spring free length	48.85 (1.9232)	47.6 (1.874)
Valve spring squareness	1.5°, max	
Load compress spring to initial working length [43 mm (1.69 in.)] kg(lb)	19 ± 1 (41.9 ± 2.21)	15 (33.08)

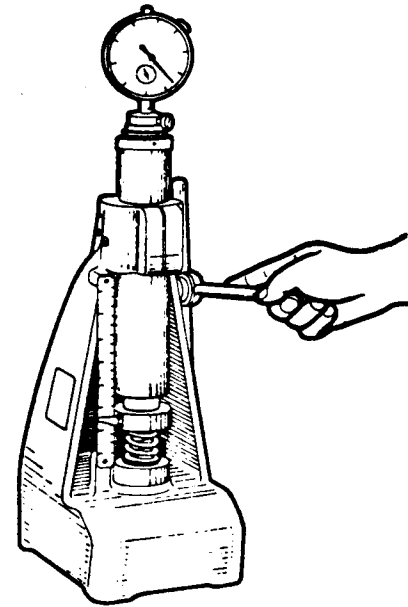

Checking valve spring

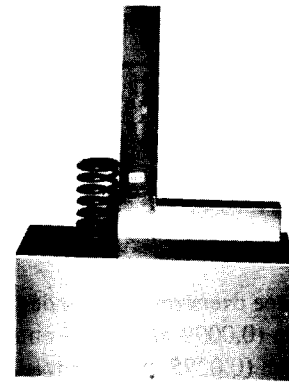

Checking valve spring for squareness

Exhaust manifold

If the flange faces are warped by more than 0.2 mm (0.0079 in.) when checked as shown, grind them smooth and flat. If any flange is found cracked, replace the manifold.

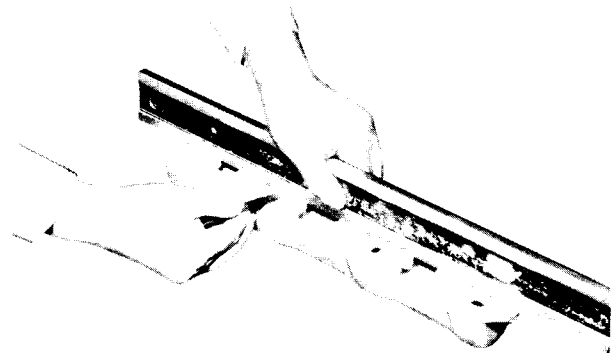

Checking exhaust manifold flange surface for flatness

Cylinder sleeves

- Using a cylinder gauge, take ID measurements in two directions (parallel and transverse to crankshaft axis) on each cylinder sleeve, at three places indicated below.

If wear reaches the repair limit, rebore the sleeve to the next specified oversize.

Specifications		Unit: mm (in.)	
Item	Standard	Repair limit	Service limit
Cylinder sleeve ID	84 ^{+0.035} ₀ (3.307 ^{+0.00138} ₀)	+0.20 (+0.008)	0.70 (0.0276)
Out of roundness	0.1 (0.004), max		
Taper	0.015 (0.0006), max		

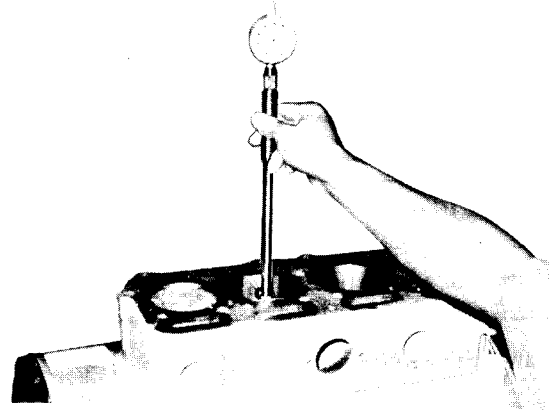

Taking ID measurements on cylinder sleeves

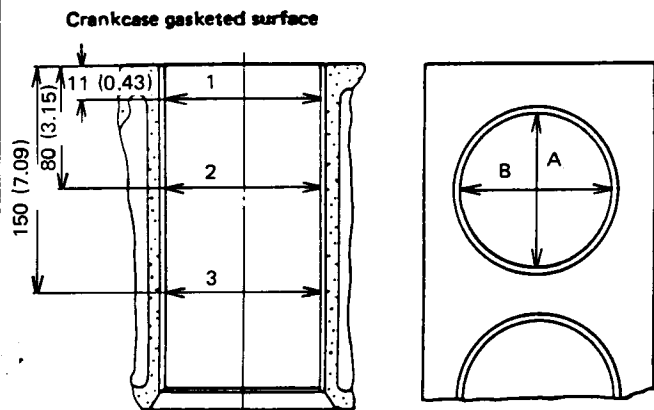

Positions for checking sleeve bore diameter

- There are three oversizes for cylinder sleeves, namely, +0.25 mm (0.0098 in.), +0.50 mm (0.0197 in.) and +0.75 mm (0.0295 in.). The tolerance to which the sleeves should be refinished by boring is 0 – 0.035 mm (0.0014 in.). When the sleeves are rebored, oversize pistons and piston rings should be used.
- An oversize to which any sleeve worn taper and/or out of round is to be rebored should be determined by relying on the most worn part of the sleeve. A cylinder sleeve whose abnormal wear is 0.4 mm (0.0157 in.) should be rebored to 1 mm (0.0394 in.) oversize, for example.

NOTE

- All cylinders should be rebored to one and the same oversize.
- When the sleeves are not worn beyond the repair limit, but the piston rings have to be renewed, correct stepped wear on the top part of the sleeve by using a ridge reamer and, if necessary, refinish the sleeves by honing.

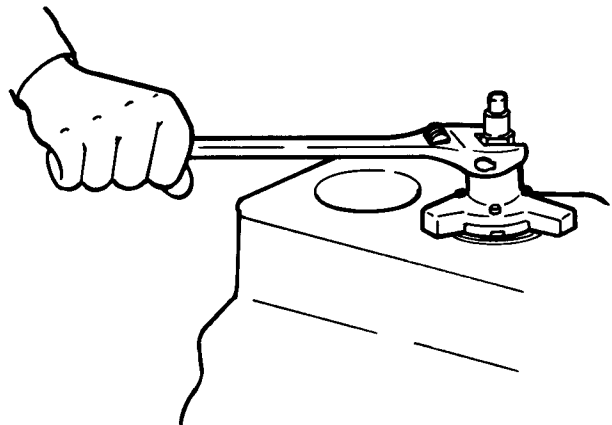

Removing ridge with ridge reamer

NOTE: This engine may be resleeved, however, a professional machine shop should be employed for that job. See the engine parts catalog for oversized sleeves.

- (4) When the sleeves are worn beyond the service limit, or when any cylinder bore is found to be defective, the sleeve should be replaced with a new one.

When the inside surfaces of one of more cylinder bores in the crankcase are found to be defective, it is necessary to refinish the bores by boring. In this case, too, the liners should be replaced with new ones. To replace, proceed as follows:

(a) Removal

- Fix a boring machine to the crankcase in alignment with the cylinder bore from which a sleeve is to be removed. Aligning should be made at the bottom part of the liner where less abnormal wear has occurred.
- Bore the sleeve until it reaches 0.5 mm (0.0197 in.) in stock thickness.
- Break the sleeve, exercising care not to damage the inside surface of the cylinder bore.

(b) Installation

- Visually check the inside surfaces of the cylinder bores for condition. It is necessary to rebores the bores if they are damaged.
- When it is unnecessary to rebores the cylinder bores, proceed as in steps below.
- Measure the diameter of cylinder bore and the outside diameter of sleeve. Select oversize sleeve so that the clearance between the sleeve and the bore is 0.08 mm (0.0031 in.) to 0.145 mm (0.0057 in.).

Heat the crankcase to about 300°C (572°F). Press the sleeve into the bores in the crankcase by using a hydraulic press in such a manner to make the top of sleeve protrude by 0.3 to 0.5 mm (0.012 to 0.020 in.) from the crankcase. Then, finish them to be flush with the crankcase.

After pressing the sleeves, rebores and hone them to them to $84 \begin{smallmatrix} +0.035 \\ 0 \end{smallmatrix}$ mm ($3.307 \begin{smallmatrix} +0.0014 \\ 0 \end{smallmatrix}$ in.).

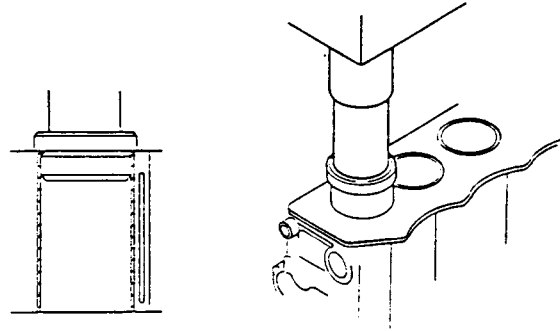

Pressing sleeve

- When it is necessary to rebores the cylinder bores, press the sleeves into position as in b above, and proceed as follows:

Prepare 0.5 mm (0.0197 in.) oversize cylinder sleeves.

Rebores the cylinder bores so that the clearance between the sleeve and the bore is 0.08 mm (0.0031 in.) to 0.145 mm (0.0057 in.).

After pressing the sleeves, rebores and hone them to them to $84 \begin{smallmatrix} +0.035 \\ 0 \end{smallmatrix}$ mm ($3.307 \begin{smallmatrix} +0.0014 \\ 0 \end{smallmatrix}$ in.).

Specifications Unit: mm (in.)

Cylinder sleeve	Sleeve boring dimension
Standard	$87 \begin{smallmatrix} -0.010 \\ -0.045 \end{smallmatrix}$ ($3.425 \begin{smallmatrix} -0.0004 \\ -0.0018 \end{smallmatrix}$)
0.5-oversize	$87.5 \begin{smallmatrix} -0.010 \\ -0.045 \end{smallmatrix}$ ($3.445 \begin{smallmatrix} -0.0004 \\ -0.0018 \end{smallmatrix}$)

When replacing the sleeves, use the sleeves of the following part numbers.

Specifications Unit: mm (in.)

Part No.	O.D.	I.D.	Remarks
30607-50301	$87 \begin{smallmatrix} +0.10 \\ +0.07 \\ +0.0004 \\ +0.0028 \end{smallmatrix}$ ($3.425 \begin{smallmatrix} +0.0004 \\ +0.0028 \end{smallmatrix}$)	$83.5 \begin{smallmatrix} 0 \\ -0.2 \\ 0 \\ -0.008 \end{smallmatrix}$ ($3.287 \begin{smallmatrix} 0 \\ -0.008 \end{smallmatrix}$)	Standard
30607-50401	$87.5 \begin{smallmatrix} +0.10 \\ +0.07 \\ +0.0004 \\ +0.0028 \end{smallmatrix}$ ($3.445 \begin{smallmatrix} +0.0004 \\ +0.0028 \end{smallmatrix}$)	$83.5 \begin{smallmatrix} 0 \\ -0.2 \\ 0 \\ -0.008 \end{smallmatrix}$ ($3.287 \begin{smallmatrix} 0 \\ -0.008 \end{smallmatrix}$)	Oversize

Pistons and piston rings

(1) Pistons

Inspect each piston for any abnormal wear of its sliding surface, for cracks at the crown and for evidence of melting or fusion. Examine the ring grooves for stepped wear and sloped wear. Replace pistons found in bad condition.

- (2) Measure the outside diameter of piston in two directions perpendicular to each other. If the diameter exceeds the service limit, replace the piston.

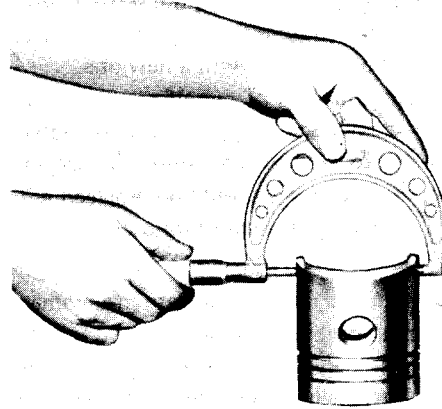

Specifications

Unit: mm (in.)

Item		Standard	Service limit
Diameter (at skirt)	Standard	83.90 (3.3031)	-0.2 (-0.008)
	0.25 (0.0098) oversize	84.15 (3.3130)	
	0.50 (0.0197) oversize	84.40 (3.3228)	
	0.75 (0.0295) oversize	84.65 (3.3327)	

(3) Replacing pistons

Replace the piston with a new one if the measurement exceeds the service limit. Where any pistons have to be replaced, the variance in weight among the pistons must not exceed the limit. It is recommended that cylinder number be stamped on a piston selected to be used in a particular cylinder for convenience.

When the cylinder sleeves are bored to the oversize, pistons and piston rings of the same oversize should be used. There are three oversizes for pistons and piston rings, namely, +0.25 mm (0.00984 in.), +0.50 mm (0.01969 in.) and 0.75 mm (0.0295 in.). The variance in weight among the pistons per engine should be ± 5 grams (± 0.18 oz), max.

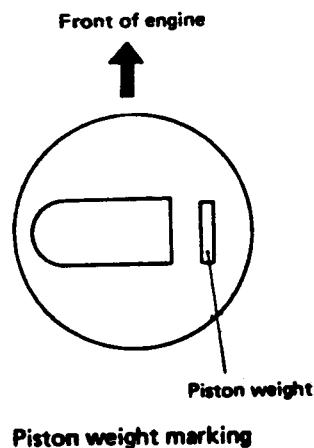

(4) Piston ring gaps

Check the ring gap with a thickness gauge by placing the ring in a new cylinder sleeve, and pushing the piston true and square in the bore.

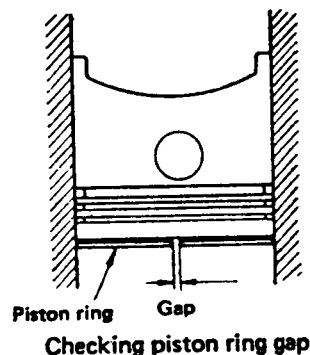

Specifications

Unit: mm (in.)

Item	Standard	Service limit
Piston ring gap	0.30 ~ 0.50 (0.0118 ~ 0.0197)	1.5 (0.059)

(5) Piston ring grooves

Insert the compression and oil rings of known thicknesses into the grooves, and measure the side clearance with a straightedge and thickness gauge (A).

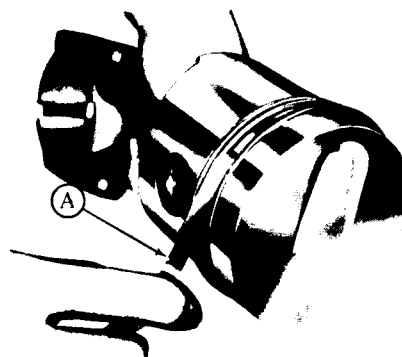

Measuring piston ring groove

Specifications

Unit: mm (in.)

Item		Standard	Repair limit
Fit in ring grooves	No. 1 compression ring	0.050 ~ 0.085 (0.00197 ~ 0.00335)	0.20 (0.0079)
	No. 2 compression ring	0.025 ~ 0.060 (0.00098 ~ 0.00236)	0.15 (0.0059)
	Oil ring		

(6) Replacing piston rings

If the rings are replaced, the gap width will exceed the standard value, but this is not a matter of concern, provided that the service limit is not exceeded.

(7) Piston pin bosses

Check the piston pin bosses by referring to the topic, Piston pins, piston pin bosses and piston pin bushings, which follows.

Piston pins, piston pin bosses and piston pin bushings

- (1) Check the pin clearance in the pin boss of the piston by computing the difference between the two diameter readings, one taken on the pin and the other in the boss. If the computed difference (clearance) exceeds the repair limit, replace the piston pin with a new one.

Specifications Unit: mm (in.)

Item	Standard	Repair limit
Piston pin diameter	$25 \begin{matrix} 0 \\ -0.006 \end{matrix}$ $(0.984 \begin{matrix} 0 \\ -0.00024 \end{matrix})$	

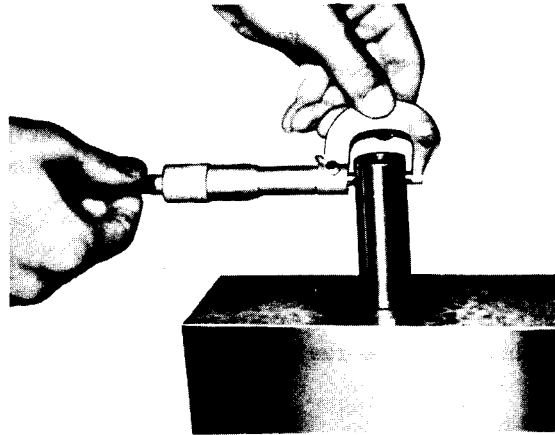

Miking piston pin bushing and piston pin

- (2) Check the clearance of the pin in the bushing fitted to the small end of the connecting rod by computing the difference between the two diameter readings. If the computed difference (clearance) exceeds the repair limit, replace the pin or the bushing whichever is badly worn.

Specifications Unit: mm (in.)

Item	Standard	Repair limit
Piston pin boss ID	$25 \begin{matrix} 0 \\ -0.006 \end{matrix}$ $(0.984 \begin{matrix} 0 \\ -0.00024 \end{matrix})$	
Piston pin clearance in piston pin boss	$0 \sim 0.016$ $(0 \sim 0.00063)$	0.05 (0.0020)
Piston pin bushing ID	$25 \begin{matrix} +0.020 \\ +0.045 \end{matrix}$ $(0.984 \begin{matrix} +0.00079 \\ +0.00177 \end{matrix})$	
Piston pin clearance in piston pin bushing	$0.020 \sim 0.051$ $(0.00079 \sim 0.00201)$	0.08 (0.0031)

Connecting rod alignment and bearings

- (1) Check the connecting rod for evidence of cracks, especially cracks in the fillets of its small and big ends. Replace the rod if any crack is noted in the fillets.
- (2) Mount each connecting rod in the connecting rod aligner and check for bend and twist as shown below. In a twisted connecting rod, the bearing is not trued to the small end bushing. Such a rod must be corrected with the use of a press.
- (3) If the connecting rod aligner is not available, the rod may be checked as follows:
 - (a) To check the rod for bend, measure "C" and "ℓ" as shown in the figure "a." If the measurement at "C" is larger than 0.05 mm per 100 mm (0.00197 in. per 3.937 in.) of "ℓ," straighten the rod with the use of a press.

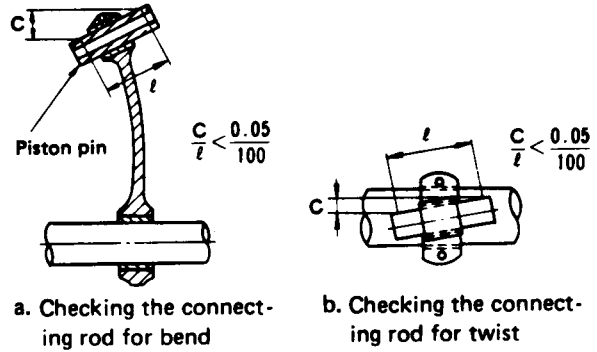

a. Checking the connecting rod for bend

b. Checking the connecting rod for twist

Checking connecting rod

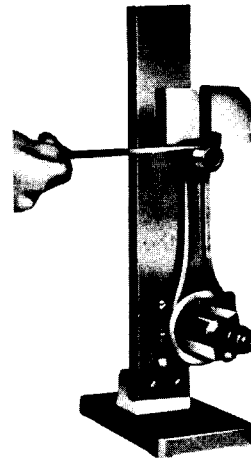

Checking connecting rod for bend

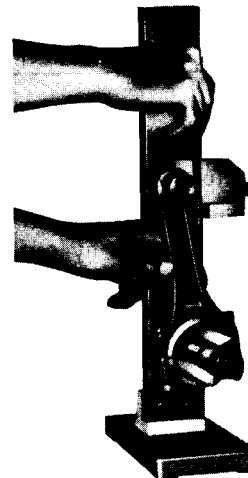

Checking connecting rod for twist

- (b) To check the rod for twist, measure "C" as shown in the figure "b." If the measurement at "C" is larger than 0.05 mm per 100 mm (0.00197 in. per 3.937 in.) of "ℓ," correct the rod.

- (4) To check the rod with a piston, place the rod on the surface plate as shown below, insert a round bar of the crankpin diameter into and through its big end bore, and take measurement at "A" and "B." The difference between the two measurements tells the straightness of the rod.

When one or more, or all connecting rods are to be replaced, select new rods so that the variance in weight among the rods is within the value given in the specification.

Specification

Unit: gram (oz)

Variance in weight among connecting rods	±25 (±0.83)
--	----------------

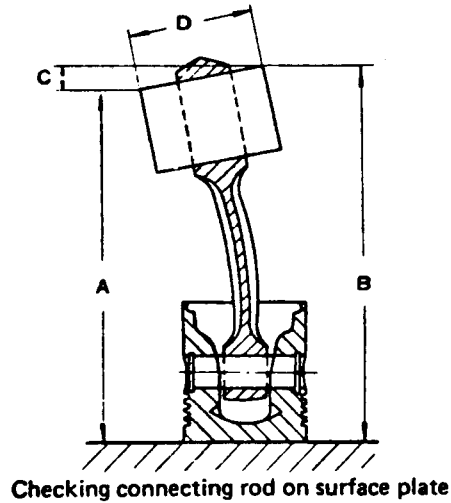

- (5) Check the connecting rod end play as follows:
Check each connecting rod for end play in the manner illustrated, with the cap bolts tightened to 5.5 kg-m (39.8 lb-ft). Use a thickness gauge to measure the end play (which is the clearance between big end and crank arm). If the clearance measured exceeds the service limit, replace the connecting rod or bearing.

Specifications

Unit: mm (in.)

Item	Standard	Service limit
Connecting rod end play	0.15 ~ 0.35 (0.0059 ~ 0.0138)	0.50 (0.0197)

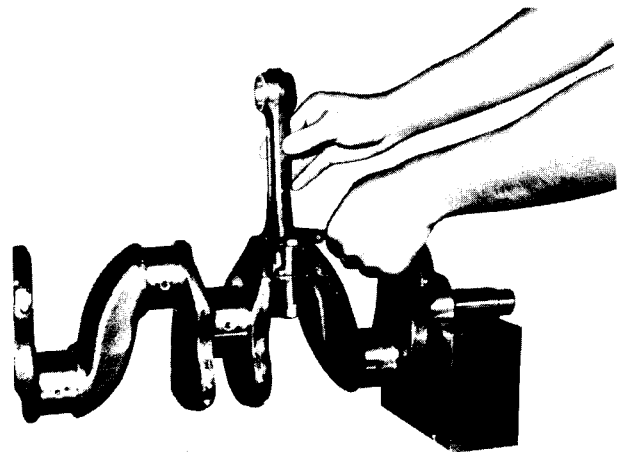

Checking end play of connecting rod

- (6) Check the bearings as follows:

- (a) Inspect each bearing for evidence of wiping or fatigue failure, for scratches by dirt particles imbedded in and for improper seating on the bore. Determine whether the bearing should be re-used or replaced on the basis of findings.
- (b) Check the radial clearance between crankpin and bearing; if the repair limit specified below is exceeded by the checked clearance, replace the bearing. Where the crankpin is to be ground to the next undersize, use a replacement bearing of that undersize.

The two bearing undersizes are 0.25 mm (0.00984 in.) and 0.50 mm (0.01969 in.).

Specifications

Unit: mm (in.)

Item	Standard	Repair limit
Crankpin diameter	58 ^{-0.035} ^{-0.055} (2.283 ^{-0.00138} ^{-0.00217})	
Radial clearance between bearing and crankpin	0.035 ~ 0.100 (0.00138 ~ 0.00394)	0.20 (0.0079)

To measure the inside diameter of the bearing, the bearing fitted to each connecting rod must be secured by tightening the cap bolts to 5.5 kg-m (39.8 lb-ft). Measure the diameter in two positions, 1 and 2, and in two directions D_1 and D_2 , as shown below. Obtain the average by the following formula:

$$D = \frac{D_1 + D_2}{2}$$

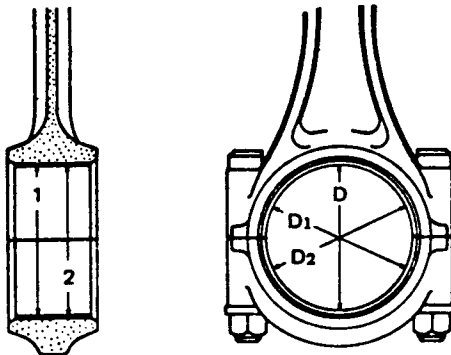

Positions for miking connecting rod bearing

- (c) Check the contact pattern of bearing on crankpin by fitting the big end in the normal manner to the crankpin, with the crankshaft laid out on the bench, and by using a paste of red lead or Prussian blue to visualize the contact. Be sure to tighten the cap bolts to the specified torque, that is, 5.5 kg-m (39.8 lb-ft). The contact should occur over at least 75% of the entire surface; if not, replace the bearing.

NOTE

The above job of checking the contact pattern may be eliminated where the crankpin is ground to the specified tolerance and the bearing has been replaced. This is because a replacement bearing is precision-finished to ensure the specified extent of contact.

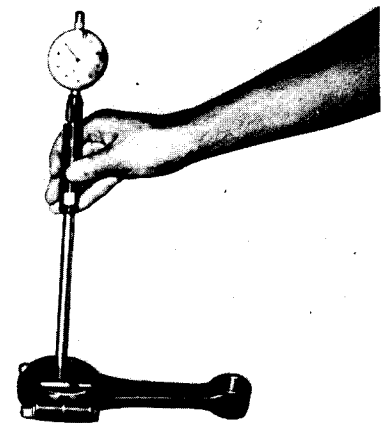

Miking connecting rod bearing

Crankcase

- (1) Inspect the outside and inside surfaces for evidence of cracking. Visually examine the cylinder bores for scuffing, rusting, erosion or any abnormal wear. Using a straightedge, check the top face (for mating with cylinder head), front face (for mating with front plate) and rear face (for mating with rear plate) for flatness.
- (2) Make sure that the top face of the crankcase is flat within the standard specified below. If the standard is found to be exceeded, reface the top by using a surface grinder to make it flat within the specified standard.

Specifications Unit: mm (in.)

Item	Standard	Repair limit
Warpage of crankcase gasketed surface	0.05, max. (0.0020)	0.20 (0.0079)

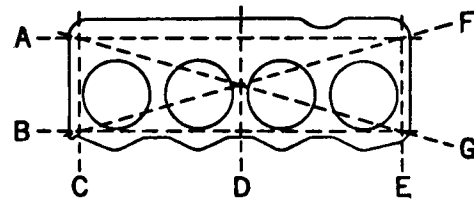

Checking crankcase top for flatness

Crankshaft

(1) Journals

- (a) Inspect each journal for surface flaws such as roughing, scratches, pitting and burns, and, as necessary, repair the journals by grinding to the next undersize or replace the crankshaft.
- (b) Mike each journal to take a total of four readings to determine the wear, out-of-round and taper (cylindricity). If any of the limits is exceeded, repair by grinding to the next undersize or replace the crankshaft.

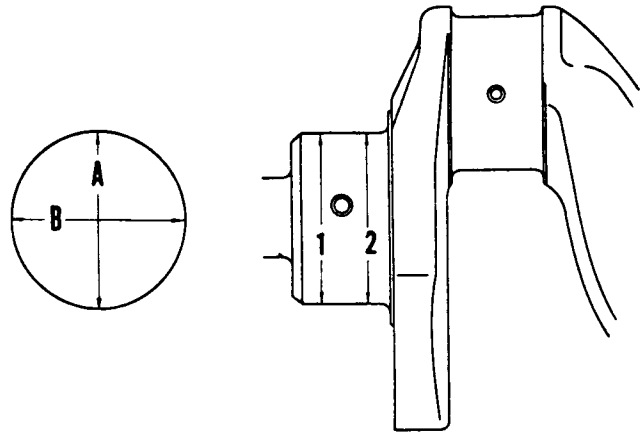

Positions for miking journal

(2) Crankpins

- (a) Inspect each crankpin for surface flaws such as roughing, scratches, pitting and burns, and, as necessary, repair the crankpins by grinding to the next undersize or replace the crankshaft.
- (b) Mike each crankpin to take a total of four readings to determine the wear, out-of-round and taper. If any of the limits is exceeded, repair by grinding to the next undersize or replace the crankshaft.

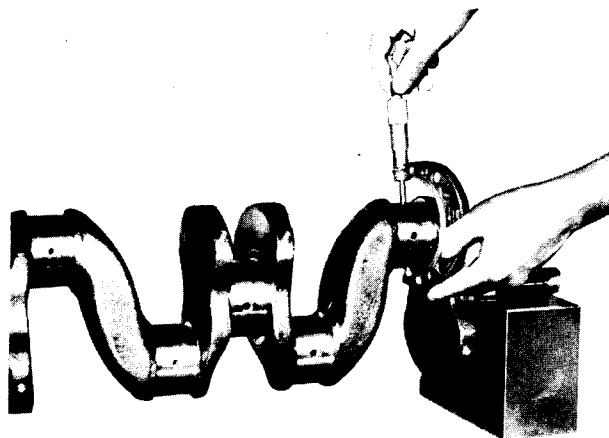

Miking crankshaft crankpins

Specifications Unit: mm (in.)

Item	Standard	Repair limit	Service limit
Diameter of journals	65 ^{-0.015} _{-0.035} (2.559 ^{-0.00059} _{-0.00138})	-0.15 (-0.0059)	-0.9 (-0.035)
Out of roundness of crankpins and journals	0.01 (0.0004), max	0.03 (0.0012)	
Taper of crankpins and journals			
Diameter of crankpins	58 ^{-0.035} _{-0.055} (2.283 ^{-0.00138} _{-0.00217})	-0.20 (-0.008)	
Fit of journals in main bearings	0.03 ~ 0.089 (0.0012 ~ 0.00350)	0.2 (0.0079) Uneven wear: 0.03 (0.0012)	

(c) Grinding the crankshaft

The crankshaft journals and crankpins must be refinished to a dimension smaller by 0.100 to 0.120 mm (0.00394 to 0.00472 in.) than the undersize of bearings to be used.

Example: If 0.50-mm (0.01969-in.) undersize bearings are to be used:

The journals must be refinished to
 $65 - 0.5 - (0.100 \sim 0.120)$
[2.55905 - 0.01969 - (0.00394 ~ 0.00472 in.)]

The crankpins must be refinished to
 $58 - 0.5 - (0.100 \sim 0.120)$
[2.28346 - 0.01969 - (0.00394 ~ 0.00472 in.)]

When grinding the crankpins and journals, be sure to produce the same filler radius (shoulder radius) as the original one. Too small a radius of fillet will result in fatigue failure of crankshaft while too large a fillet radius is sure to cause the bearing to ride on the radius and thereby to result in a bearing failure. Be extremely careful not to grind off the radius part beyond the desired dimension. An over-ground radius part can be corrected only by grinding off the shoulder face and this, if effected, will present problems in obtaining a proper end clearance.

Also check the crankpins and journals for hardness. They should have a hardness of 620 or more in terms of Vickers Hardness Number. If necessary, re-harden the crankpins and journals, and check them for cracks by conducting a magnaflux (magnetic particle) test.

Specifications Unit: mm (in.)

Undersize	Journals to be refinished to
0.25 (0.0098)	$64.75_{-0.035}^{-0.015}$ ($2.54921_{-0.00138}^{-0.00059}$)
0.50 (0.0197)	$64.50_{-0.035}^{-0.015}$ ($2.53937_{-0.00138}^{-0.00059}$)
0.75 (0.0295)	$64.25_{-0.035}^{-0.015}$ ($2.52952_{-0.00138}^{-0.00059}$)

(3) End play

Check the crankshaft for end play, as shown, by using a thickness gauge at the thrust bearing. If the limit is reached replace the thrust plate.

Specifications Unit: mm (in.)

Item	Standard	Repair limit
Journal width for thrust bearing	0.100~0.189 (0.00394~0.00744)	0.3 (0.012)

The end play is due to the difference between the width of thrust bearing and the dimension (A) indicated below:

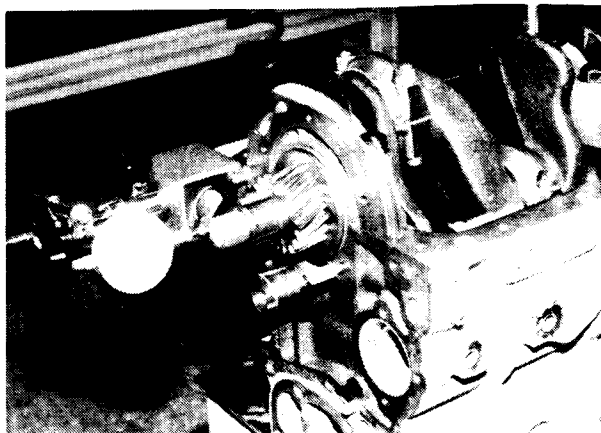

Checking crankshaft end play

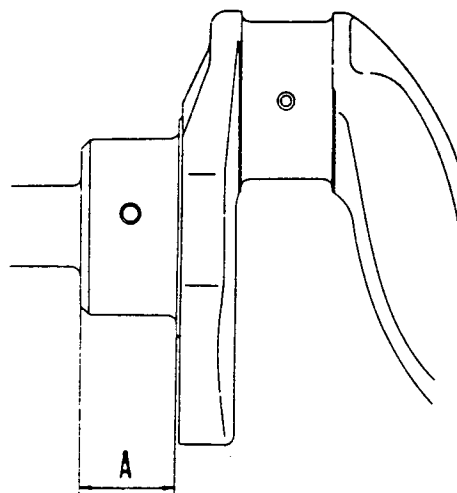

J8800

Journal width for thrust bearing

(4) Runout

Support the crankshaft as shown and roll it to measure its deflection with a dial gauge. "Distortion" is one-half of the deflection (dial gauge reading); if it exceeds the standard, reduce it by bending the crankshaft in a press.

Specifications Unit: mm (in.)

Item	Standard	Repair limit
Crankshaft runout	0.02 (0.0008), max	0.05 (0.0020)

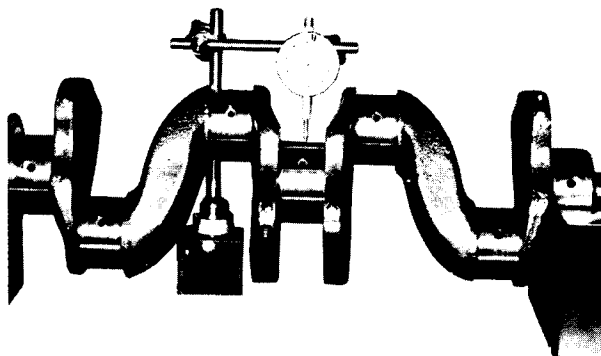

Checking crankshaft for runout

(5) Main bearings

Inspect each main bearing for evidence of wiping or fatigue failure, for scratches by dirt particles imbedded and for improper seating on the bore (bearing cap). On the basis of findings, determine whether the bearing should be replaced or not.

Check each main bearing to be used in engine reassembly to see whether it will provide the specified radial clearance. This can be accomplished in this manner.

Install the main bearings on the crankcase, less the crankshaft, securing each bearing cap by tightening its bolts to 8.5 kg-m (61.5 lb-ft) and read the diameter in the two directions (A) (B), in indicated below. Mike the journal and, from these readings, compute the radial clearance.

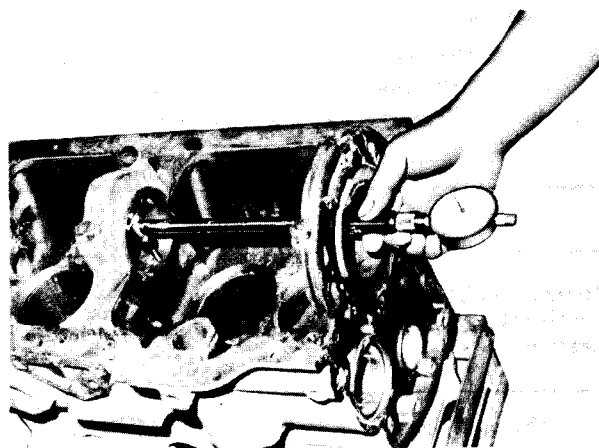

Measuring main bearing ID

Specifications Unit: mm (in.)

Item	Standard	Repair limit
Fit of main bearings on journals	0.03 ~ 0.089 (0.0012 ~ 0.00350)	0.200 (0.00787)

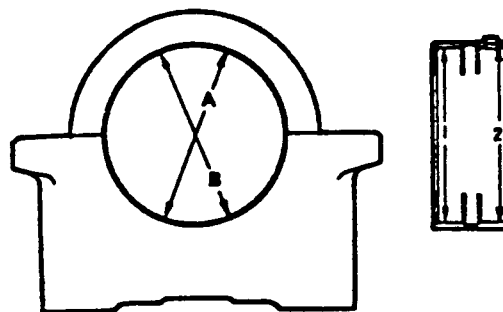

Positions for miking main bearing

Camshaft

- (1) Check the camshaft end play as outlined for the timing gears. Where the end play exceeds the repair limit, replace the thrust plate with a new one.

Specifications Unit: mm (in.)

Item	Nominal value	Standard	Repair limit
Camshaft end play	5.0 (0.197)	0.05 ~ 0.112 (0.00197 ~ 0.00441)	0.3 (0.012)

- (2) Inspect the camshaft journals for abnormal wear and damage; the camshaft must be replaced if any of its three journals is found in bad condition beyond repair.
- (3) Mike each cam of the camshaft to read D_1 (cam height) and D_2 (diameter), and compute the difference between D_1 and D_2 . If this difference is less than the service limit, replace the camshaft.

Specifications Unit: mm (in.)

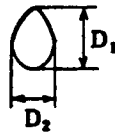
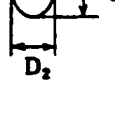
Item	Standard	Service limit
Intake cam profile 	$D_1: 46.916^{+0.1}_{-0.3}$ $(1.84708^{+0.00394}_{-0.01181})$ $D_1 - D_2 = 6.684$ (0.26315)	$D_1 - D_2 = 6.184$ (0.24346)
Exhaust cam profile 	$D_1: 45.944^{+0.1}_{-0.3}$ $(1.80882^{+0.00394}_{-0.01181})$ $D_1 - D_2 = 7.344$ (0.28913)	$D_1 - D_2 = 6.844$ (0.26945)

- (4) Check the camshaft for runout. Straighten the camshaft in a press or replace it, as necessary.

Specifications Unit: mm (in.)

Item	Standard	Repair limit
Camshaft runout	0.02 (0.0008), max.	0.05 (0.0020)

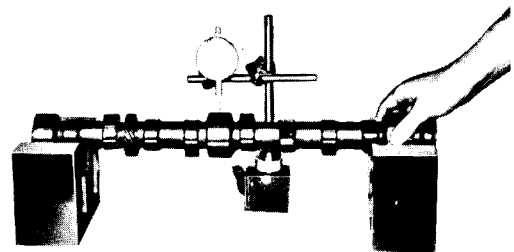

Checking camshaft runout

- (5) Measure the diameter of each journal in two directions to compute the fit or clearance in the camshaft hole.

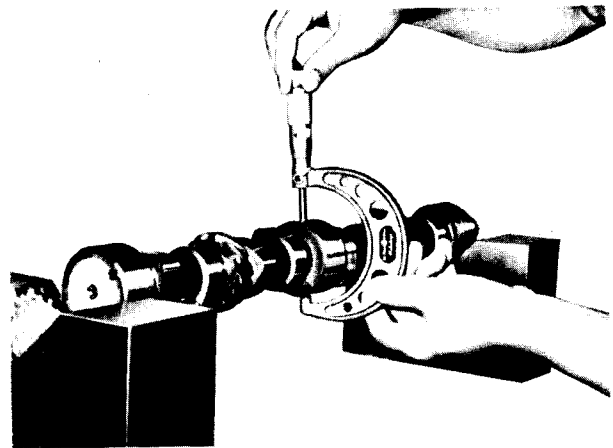

Miking camshaft journals

- (6) Measure the ID of camshaft holes (bushings) and compute the fit on each journal. If the fit exceeds the repair limit, machine the holes and install bushings.

Specifications Unit: mm (in.)

Item	Standard	Repair limit
Fit of camshaft journals in holes (bushings)	0.040 ~ 0.090 (0.00157 ~ 0.00354)	0.15 (0.0059)

Specifications Unit: mm (in.)

Item	Standard	Service limit
Camshaft bushing inside diameter	No.1, 2 54H7 $\begin{matrix} +0.030 \\ 0 \\ (2.126H7 +0.00118) \\ 0 \end{matrix}$	
	No.3 53H7 $\begin{matrix} +0.030 \\ 0 \\ (2.087H7 +0.00118) \\ 0 \end{matrix}$	
Camshaft journal outside diameter	No.1, 2 54 $\begin{matrix} -0.040 \\ -0.060 \\ (2.126 -0.00157) \\ -0.00236 \end{matrix}$	-0.1 (-0.004)
	No.3 53 $\begin{matrix} -0.040 \\ -0.060 \\ (2.087 -0.00157) \\ -0.00236 \end{matrix}$	

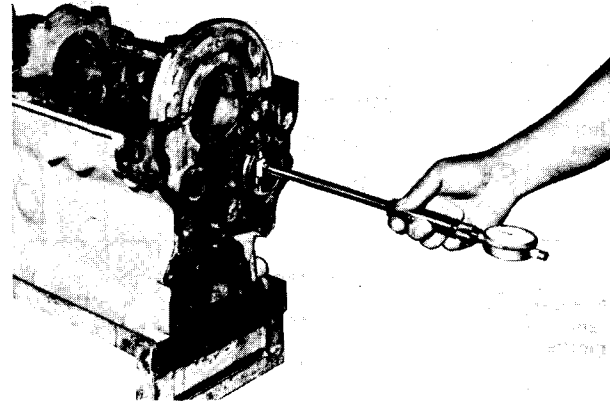

Miking camshaft hole ID

Tappets and tappet holes

- (1) Inspect the riding face of each tappet for wear, contact pattern and crack. Replace defective tappets.
- (2) Check the fit of the tappet in the hole against the repair limit, indicated below. If the limit is exceeded, then replace the tappet. If the hole is worn down so much as to provide an excessive radial clearance even with a new tappet, the crankcase must be replaced.

Specifications Unit: mm (in.)

Item	Standard	Repair limit	Service limit
Fit of holes on tappets	0.035 ~ 0.098 (0.00138 ~ 0.00386)	0.12 (0.0047)	+0.10(hole) (+0.0039)
Tappet hole diameter	22 (0.87)		+0.10 (+0.0039)

Flywheel

- (1) Check the flywheel for scoring or a sign of overheating of the friction surface, cracks, or any other damage. When any of these damages are presented, repair or replace the flywheel.

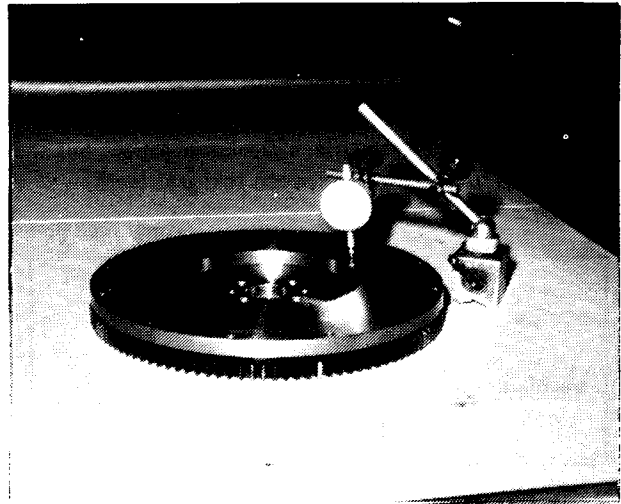

Checking flywheel friction surface for warpage

- (2) Check the friction surface for warpage and/or face runout. When warpage or face runout exceeds the repair limit, repair or replace the flywheel. The face runout may be measured by means of a dial gauge with the flywheel installed on the crankshaft.

Specifications		Unit: mm (in.)
Item	Standard	Repair limit
Warpage	0.15(0.0059), max.	0.5 (0.020)
Face runout	0.15(0.0059), max.	0.5 (0.020)

- (3) Check the flywheel attaching bolt threads for condition and replace a damaged bolt, if any.
- (4) Check the ring gear for condition and replace it if damaged.
- (5) Clean the pilot bushing which is fitted into the center bore in the flywheel, and check it for condition. Replace the bushing if damaged.

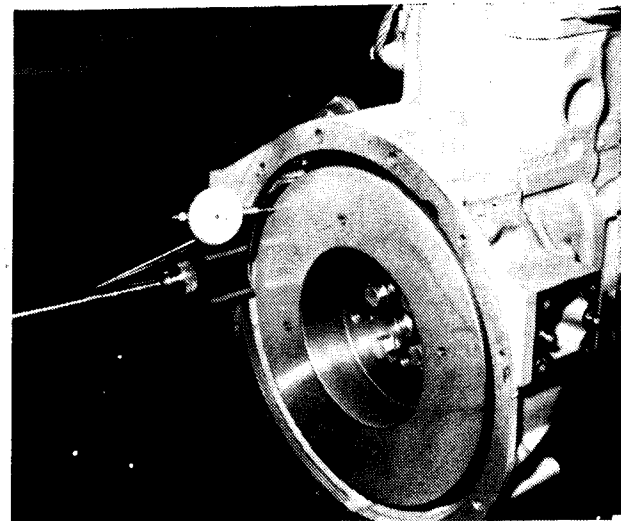

Checking flywheel friction surface for face runout

Timing gear case and oil seal

- (1) Check the timing gear case for any signs of cracks: also check the dowel pin holes for condition.
- (2) Check the oil seal for wear, and replace it if it is excessively worn or otherwise defective. Check it more carefully if oil leakage from the crankshaft end is excessive.

Timing gears

- (1) Be sure that the backlash in each mesh is within the repair limit. If the limit is exceeded, reduce the backlash by replacing the worn gear. To measure backlash, use a thickness gauge: put the gauge squarely into between two gear teeth.

Specifications		Unit: mm (in.)
Item	Standard	Repair limit
Backlash	0.05 ~ 0.20 (0.0020 ~ 0.0079)	0.25 (0.0098)

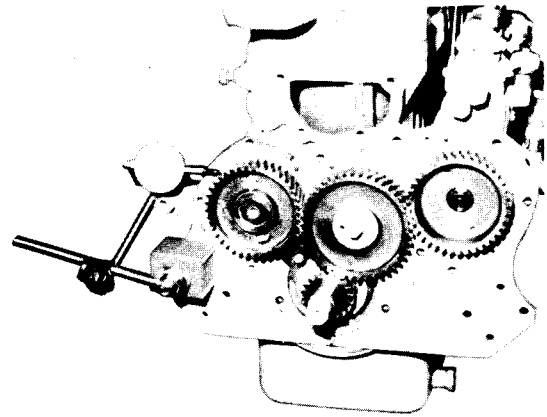

- (2) Check the radial clearance between idler bushing and shaft by miking. Compute the clearance from the readings taken and, if the repair limit is exceeded, replace the bushing.

Specifications		Unit: mm (in.)	
Item	Nominal	Standard	Repair limit
Fit of shaft in idler bushing	36 (1.417)	0.025 ~ 0.075 (0.00098 ~ 0.00295)	0.1 (0.004)

- (3) Check the idler end play with a thickness gauge. Replace the thrust plate to reduce the play if the thickness gauge reading exceeds the repair limit.

Specifications		Unit: mm (in.)
Item	Standard	Repair limit
Idler end play	0.05 ~ 0.15 (0.0020 ~ 0.0059)	0.35 (0.0138)



Checking idler end play

- (4) If the idler shaft has to be replaced, use the idler shaft puller to remove it, as shown. When installing the replacement shaft, check to be sure that the oil holes are aligned.

- (5) Inspect the timing gears as follows:

(a) Camshaft gear

Replace the gear if its teeth show evidence of flaking or excessive wear, or if its keyway is galled, worn or otherwise disfigured. Make sure that the camshaft gear as mounted on the camshaft has no more end play than 0.4 mm (0.0157 in.): to check the end play, use a dial gauge. If the reading exceeds the repair limit, replace the thrust plate. (Remember, this gear is shrink-fitted to the camshaft.)

Specifications Unit: mm (in.)

Item	Standard	Repair limit
Camshaft end play	0.05 ~ 0.112 (0.00197 ~ 0.00441)	0.3 (0.012)

- (b) **Injection pump drive gear**
Inspect the gear teeth for damage and also the mounting bolt holes for malfunction. Replace the gear if found in badly damaged condition.
 - (c) **Crankshaft gear**
Replace the gear if its teeth show signs of defective tooth contact, or are excessively worn or otherwise defective.
 - (d) **Idler gear**
Inspect the idler gear teeth and, as necessary, replace the gear.
- (6) Inspect the gear case for cracks, and for evidence of oil leakage at the part ahead of the crankshaft. A cracked case must be replaced. Inspect the crankshaft pulley, too, examining condition of surface in contact with the oil seal and checking the keyway and key for wear. Replace the pulley if found in defective condition.

REASSEMBLY

- (1) Reassemble the connecting rod and piston as follows:
 - (a) Drive in bushing into connecting rod small end. The oil holes in bushing and rod must be aligned.

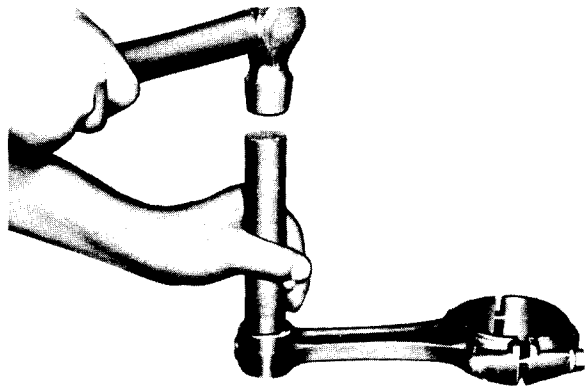

- (b) Heat piston with piston heater up to 100°C to 120°C (212°F to 248°F). Install small end of connecting rod into boss and connect piston and piston pin by slowly inserting piston pin into piston. Insert snap ring in one end in advance. Install connecting rod to piston so that the marking side of the connecting rod big end comes to the camshaft side.

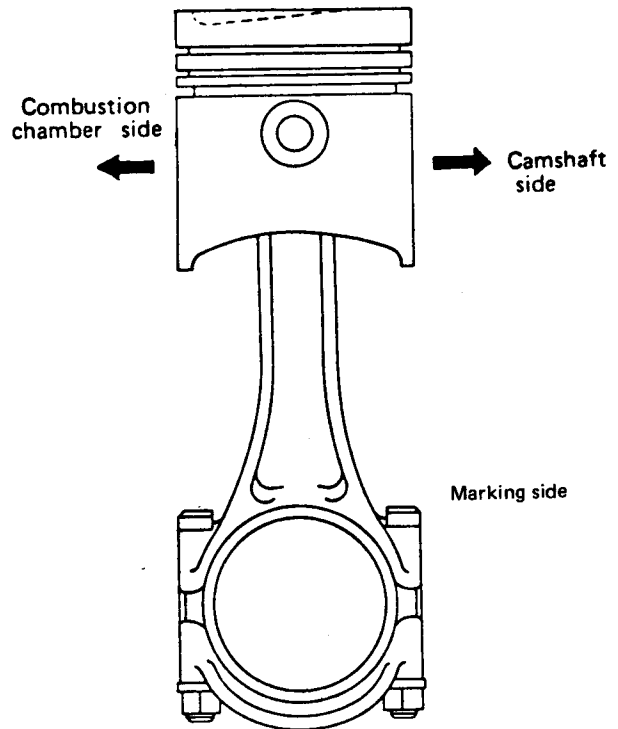

PISTON AND CONNECTING ROD ASSEMBLY

- (c) Install compression rings and oil control ring as shown by using piston ring tool.

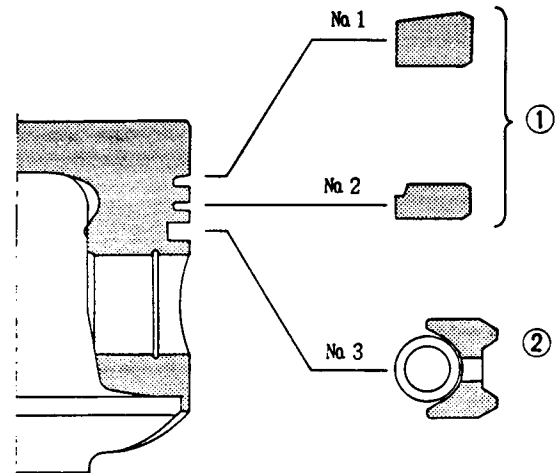

PISTON RINGS INSTALLED

1—Compression rings 2—Oil control ring

NOTE

No. 2 ring has "R" or "RN" mark on its top side. Be sure that this side is on top when the ring is in the groove.

This mark comes on top side.

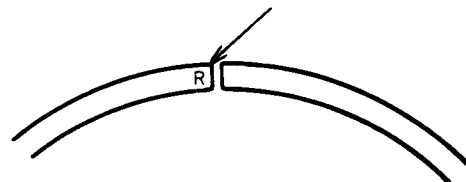

- (d) Install No. 3 oil control ring (1) and expander (2) as shown below.

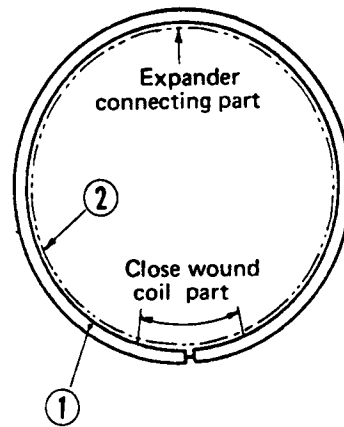

J 8693

OIL CONTROL RING AND EXPANDER INSTALLED

- (2) Reassemble the crankcase as follows:

- (a) Drive three camshaft bushings (1) into camshaft holes in crankcase by using adapter (A).
(If the fit exceeds the repair limit, machine the holes and install bushings.)

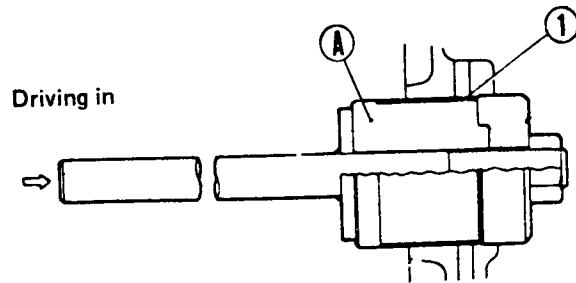

DRIVING IN CAMSHAFT BUSHING

- (b) Drive idler shaft (2) into crankcase by using installer (B).

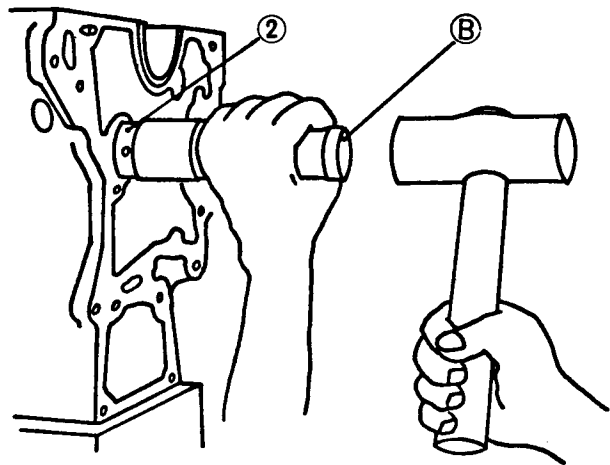

- (c) Lightly apply engine oil to the crankpins and install main bearings (upper). Securely engage the bearings with the crankpins.

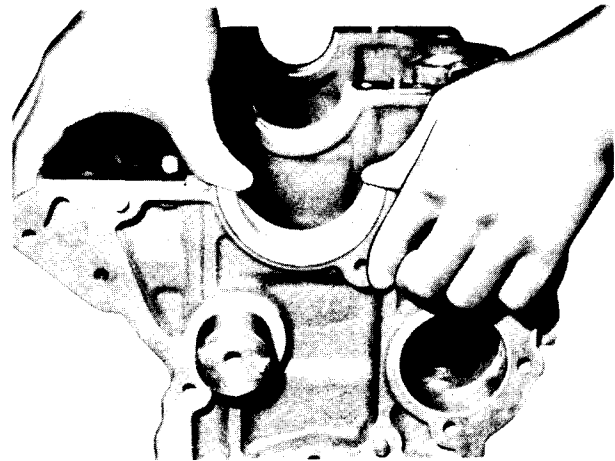

- (3) Install the piston assembly as follows:

Install connecting rod bearing (upper) (1) into the big end of connecting rod. Apply engine oil in the internal surface of bearing and on the external periphery of piston. Position piston rings so that ring gaps are located 90° in respect with each other as shown, and then insert piston assembly (2) into crankcase. Alignment marks on the connecting rod must face the camshaft side. Put cap attaching bolts (3) into rod in advance. Insert piston assembly into crankcase by using piston guide (A).

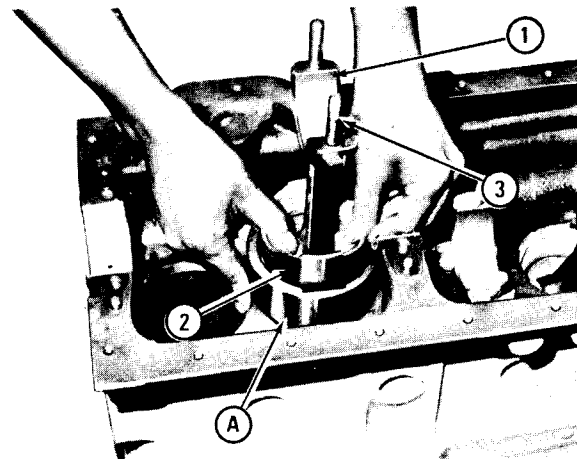
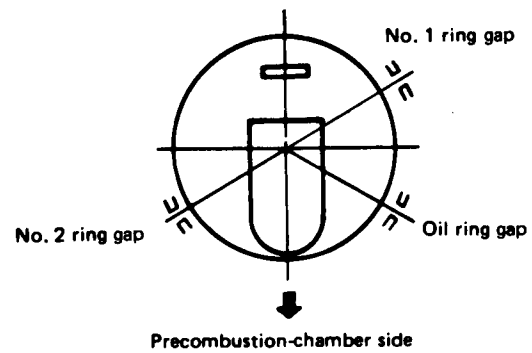

(4) Install the crankshaft as follows:

- (a) Install thrust plate (1) and two woodruff keys (2) to the crankshaft and drive in crankshaft gear (3) by using installer (A).
- (b) Install crankshaft to the crankcase.

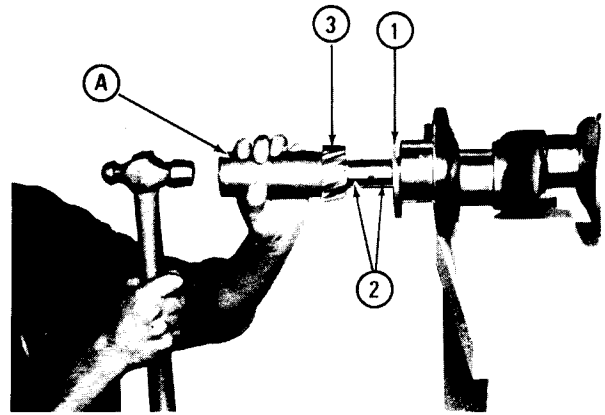

(5) Install the main bearing caps as follows:

- (a) Apply engine oil to the crankshaft journals and pins, and install the crankshaft in the crankcase securely. Attach main bearing (lower) (1) to main bearing cap (2) (front, center and rear) and install the cap in place aligning it with dowel pin (A) of crankcase.

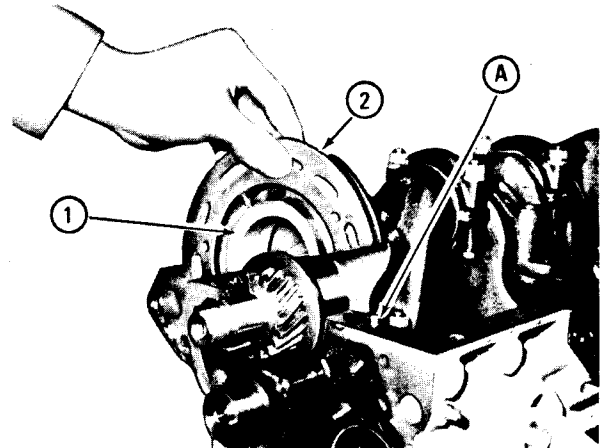

- (b) Measure the crankshaft end play with a thickness gauge. Replace No.1 main bearing if the end play is out of specification. Tighten main bearing cap bolts (3) to a torque of 8.5 kgm (61.463 lb.ft).

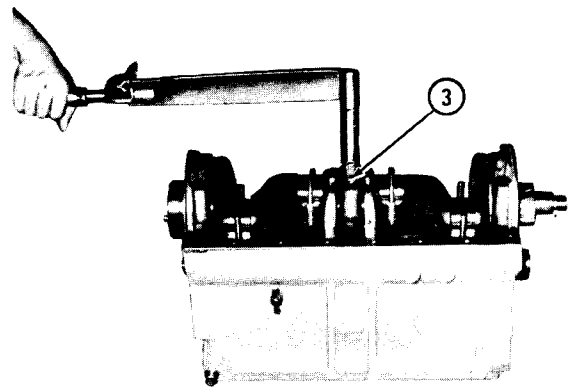

(6) Install the connecting rod bearing caps as follows:

- (a) Install connecting rod bearing (lower) (2) into cap (1) and apply engine oil to the internal surface of the bearing, and then install the cap with the matching mark on the cap aligned with the mark (A) on the rod.

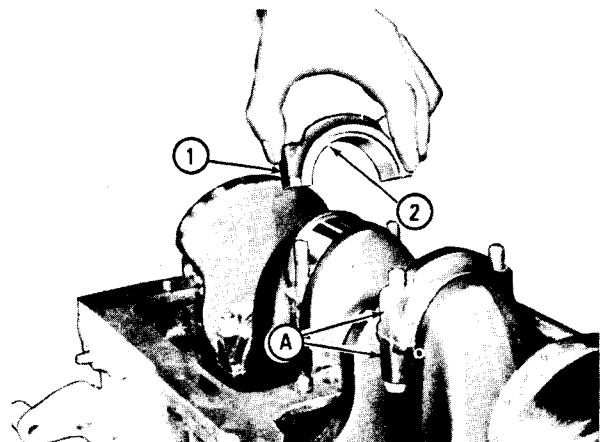

- (b) Tighten connecting rod clamping nuts to a torque of 5.5 kgm (39.771 lb.ft).

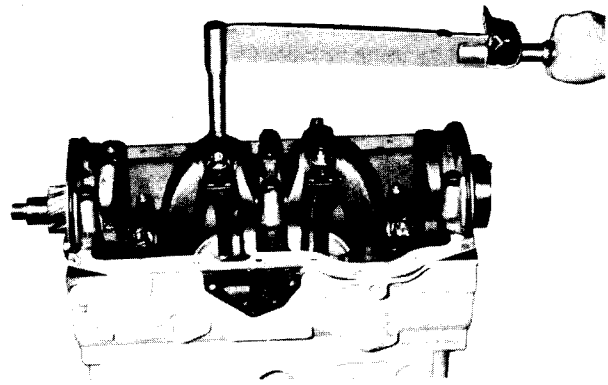

- (7) Install the retainers and gaskets as follows:

- (a) Install retainers (1) to the external peripheries of main bearing caps No. 1 and No. 3 with the flange facing the case inside.

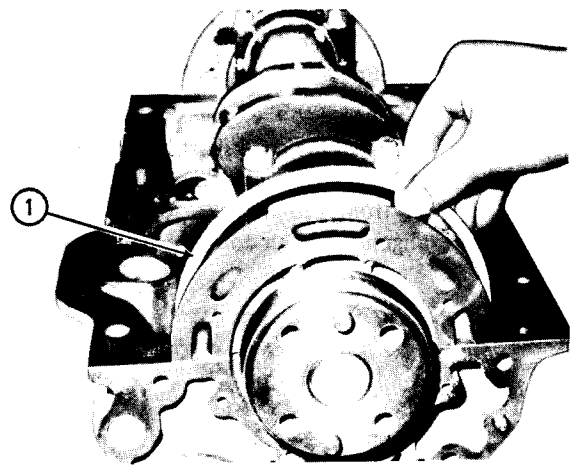

- (b) Apply ThreeBond 1102 (adhesive) on both sides of oil pan gasket (2) and attach it to crankcase. Make sure that the gasket is completely attached in the grooves (A) in the caps.

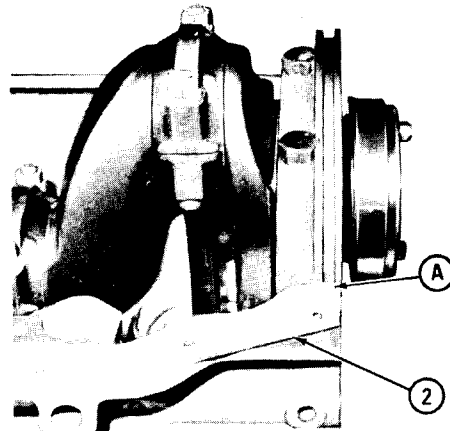

- (c) Apply Atomjet on the both ends of rubber packing (3) and insert the packing into cap.



- (d) Install sleeve onto the rear end of crankshaft. Apply clean engine oil to the internal surface of oil seal (1) and secure it with bolts (2) by using oil seal aligner.
- (e) Apply Atomjet at the tip of bolts (3) as they fit into four through-bolt holes in the bearing cap. Tighten the bolts to a torque of 0.4 kgm (2.9 lb.ft).

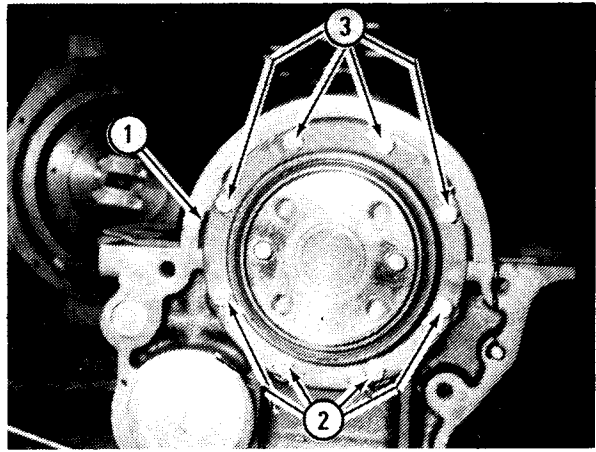

- (8) Install the front plate as follows:

- (a) Apply ThreeBond 1102 to the both sides of front plate packing and attach the packing to the front face of crankcase. Secure front plate (1) with injection pump installed with two bolts (2). The tightening torque of the bolts is 2.1 kgm (15.2 lb.ft).

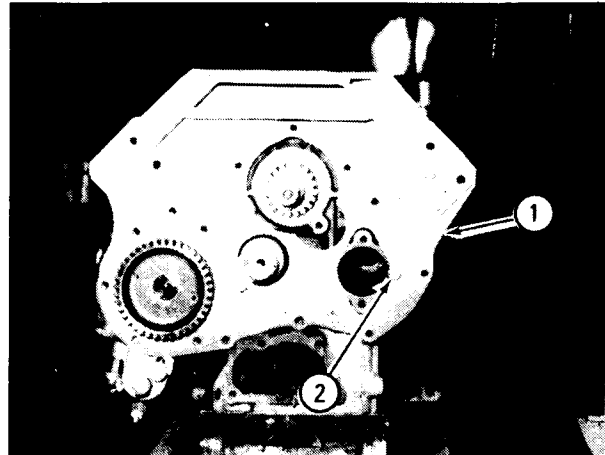

- (b) Heat camshaft gear to 150°C to 180°C and fit it to shaft.

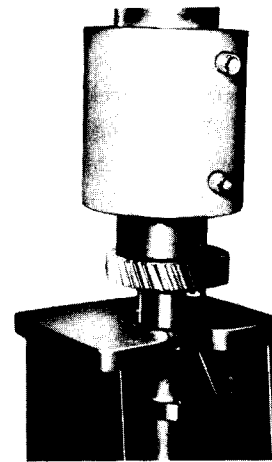

- (c) Slowly insert camshaft into crankcase.

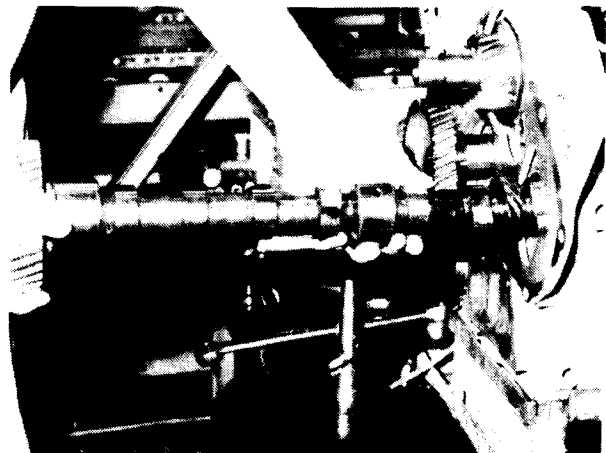

- (d) Tighten camshaft thrust plate to crankcase by using machining holes in camshaft gear.

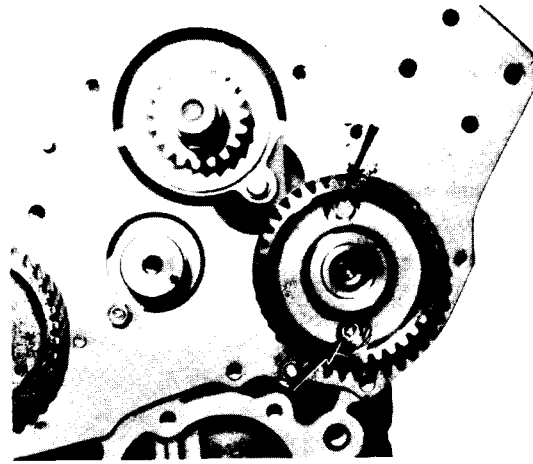

- (9) Install the idler gear as follows:

- (a) Install idler gear by matching the timing mark on each gear.

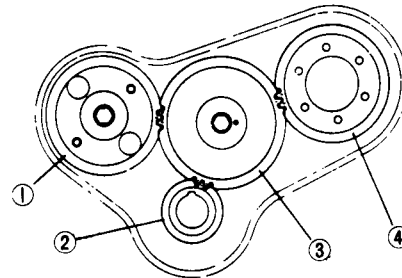

Timing gear match marks meeting each other

- 1-Camshaft gear 3-Idler gear
2-Crankshaft gear 4-Injection pump gear

- (b) Inspecting valve timing after installation of timing gears

It is not necessary to check the valve timing, provided that all matching marks on the timing gears are aligned. Check the timing for verification as follows:

Using a 3 mm (0.12 in.) thick smooth steel plate, add 3 mm (0.12 in.) clearance to intake and exhaust valves of No. 1 cylinder. Then, insert a 0.05 mm (0.0020 in.) thickness gauge into between the top of valve cap and rocker, and slowly turn the crankshaft, trying to find a position where the thickness gauge is firmly gripped (the valve starts opening) and a position where the gauge is just ungripped (the valve starts closing). Check to make sure that these positions coincide with the angular positions shown in the valve timing diagram with 3 mm (0.12 in.) clearance added to the valves.

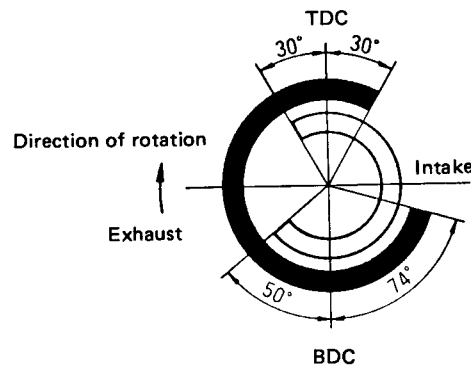

Valve timing diagram

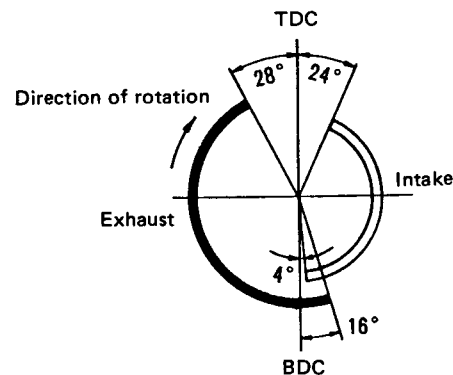

Valve timing diagram with 3 mm (0.12 in.) clearance added to valves

(10) Install the oil pump assembly as follows:

- (a) Install oil pump into the oil pump installation hole in the crankcase and mesh the pump drive gear with camshaft pump drive gear.
- (b) Tighten bolt and secure the oil pump.

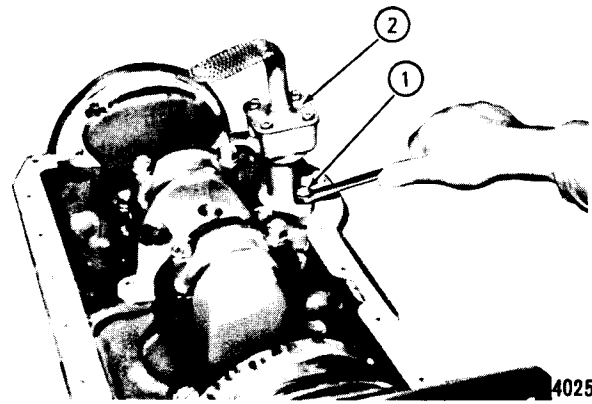

(11) Install the oil pan.

(12) Install the rear plate and flywheel as follows:

- (a) Drive in dowel pin (1), and secure flywheel (2) complete with pilot bearing in place with bolts (4) and lock washers (3).
- (b) Bend lock washers properly to lock bolts.

Unit: kg-m (lb-ft)

Flywheel bolt tightening torque	8.5 ± 0.5 (61.5 ± 3.6)
------------------------------------	---------------------------

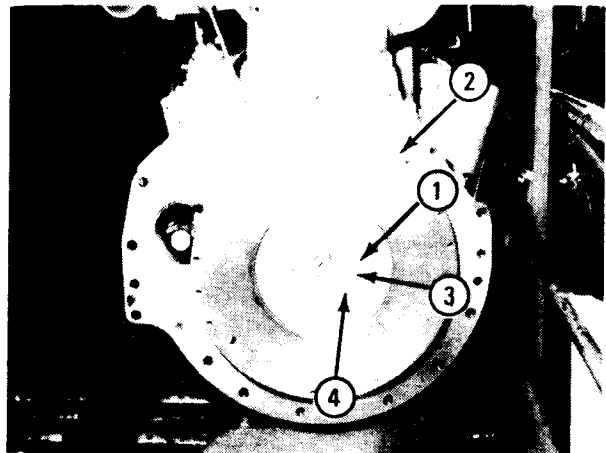

(13) Reassemble the cylinder head as follows:

- (a) Drive valve guide (2) into cylinder head (1) as shown.

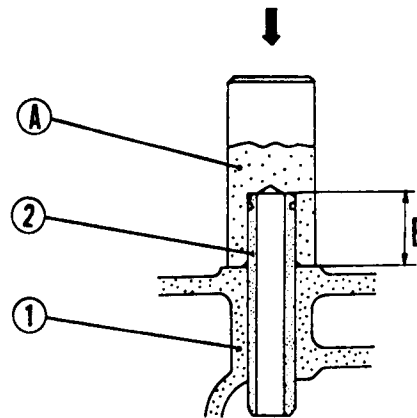

1—Cylinder head 2—Valve guide A—Valve guide installer B—As-installed length: 18mm(0.709 in)

Install stem seal (3) to the valve guide. Completely fit the breast of the seal in the guide groove.

- (b) Install valve (4), valve spring (5) and retainer (6) in this order. Compress the spring with a valve lifter to install valve cotter (7) securely. Install caps (8) when installing rocker shaft assembly.
- (c) Install thermostat, nozzle holders, glow plugs and exhaust manifold in the cylinder head.

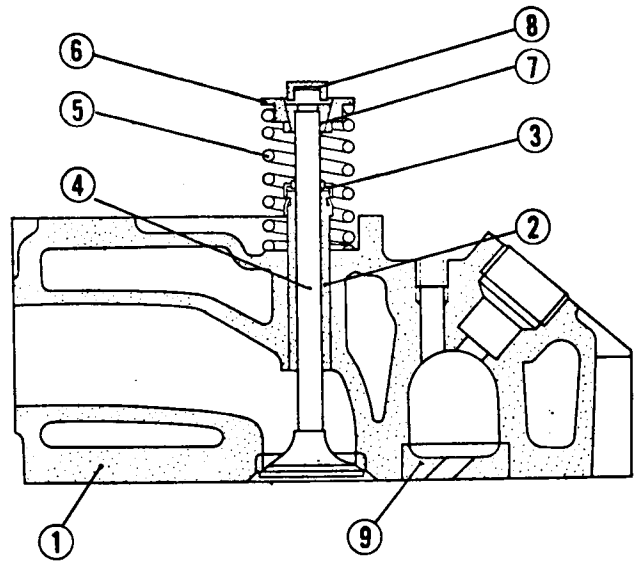

CYLINDER HEAD ASSEMBLY

1—Cylinder head 2—Valve guide 3—Stem seal 4—Valve
5—Valve spring 6—Retainer 7—Valve cotter 8—Valve cap
9—Combustion chamber jet

(14) Install the cylinder head assembly as follows:

- (a) Place the gasket (1) to crankcase (2) and install cylinder head (3). Use two guide bolts (4) to prevent the gasket from moving when placing cylinder head to the crankcase.

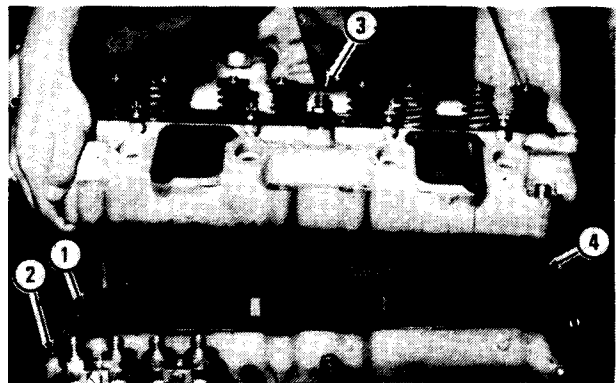

CAUTION

Do not apply any sealant to the gasket.

- (b) Tighten the cylinder head bolts to a torque of 12 kg-m (86.8 lb-ft) at exhaust side and at intake side in the sequence shown below.

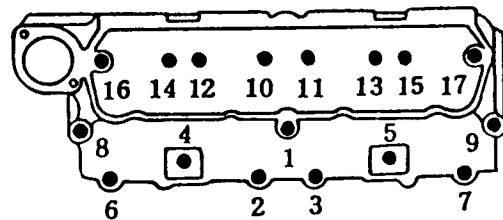

402507

(15) Install the push rods and rocker shafts as follows:

- (a) Insert the push rods (1) into the tappets.
- (b) Install rocker shaft assembly as follows:
- (c) Insert "O" rings (3) into oil pipe (2) and connect the oil pipe to the front and rear rocker shafts. Then temporarily install each bracket to the cylinder head.
- (d) Temporarily tighten two or three threads on the oil pipe union nut and connector.
- (e) Secure the preinstalled brackets by tightening four bolts at the front and rear sides uniformly to a torque of 1.5 kg-m (10.85 lb-ft). Tighten the long bolts (4) first.
- (f) Connect oil pipe to connector securely. Then adjust the valve clearance to 0.25 mm (0.01 in.) for both intake and exhaust valves in cold setting.

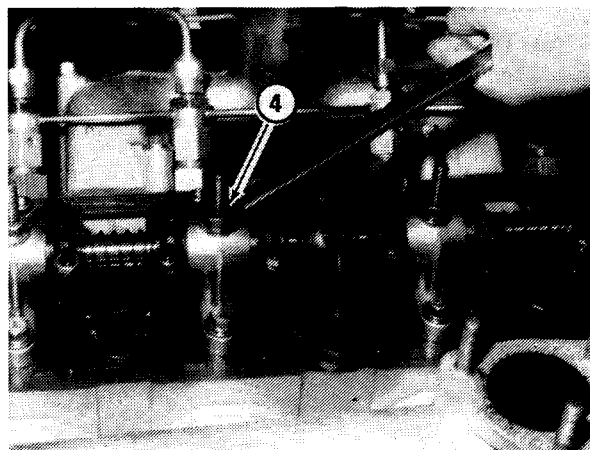
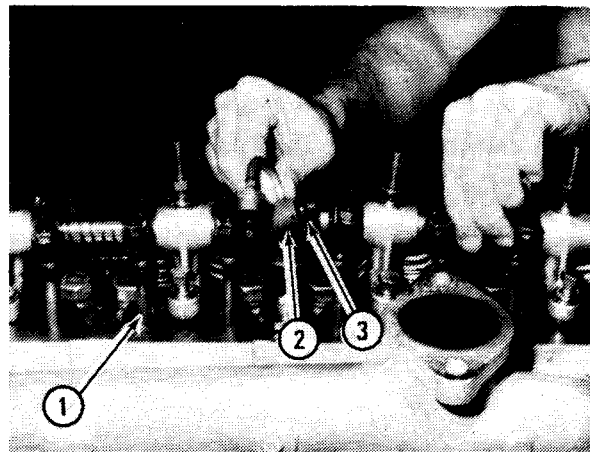

(16) Adjust valve clearance as follows:

The valve clearance specification for this engine is 0.25 mm (0.0098 in.) for both intake and exhaust valves. This value assumes that the engine is at normal temperature, there being no temperature difference throughout the body of the engine. The checking and adjusting procedure is as follows:

- (a) Rotate the crankshaft slowly to bring the piston in No. 1 cylinder to Top Dead Center (TDC). This can be accomplished by observing rocker arms of No. 4 cylinder. As you turn the crankshaft, exhaust-valve rocker arm of this cylinder rises: stop turning the crankshaft just when intake-valve rocker arm begins to go down after exhaust valve rocker arm has come up all the way. Under this condition, adjust valve clearance in the usual manner on intake and exhaust valves of No. 1 cylinder, intake valve of No. 2 cylinder, and exhaust valve of No. 3 cylinder.
- (b) Turn the crankshaft one complete rotation (360°), and hold it there. Adjust the clearance on intake and exhaust valves of No. 4 cylinder, exhaust valve of No. 2 cylinder, and intake valve of No. 3 cylinder.

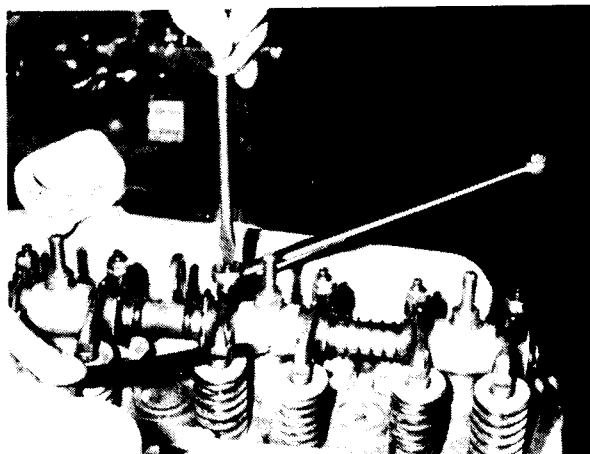

- (17) Install the rocker case.
- (18) Install the water pump assembly as follows:
- (a) Install water pump assembly.
 - (b) Install bypass hose and oil pipe.
- (19) Install the timing gear case (1) to the front plate properly. Use copper packing for bolts (2) to prevent oil leakage.

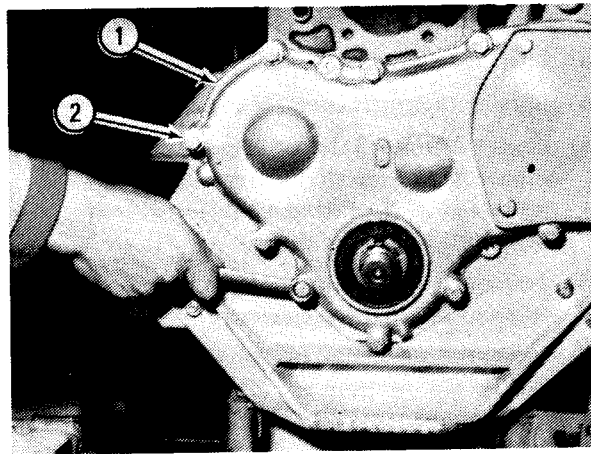

- (20) Install the water pump pulley and crankshaft as follows:
- (a) Drive in water pump pulley (1) and crankshaft pulley (2) by using installers (A) and (B).

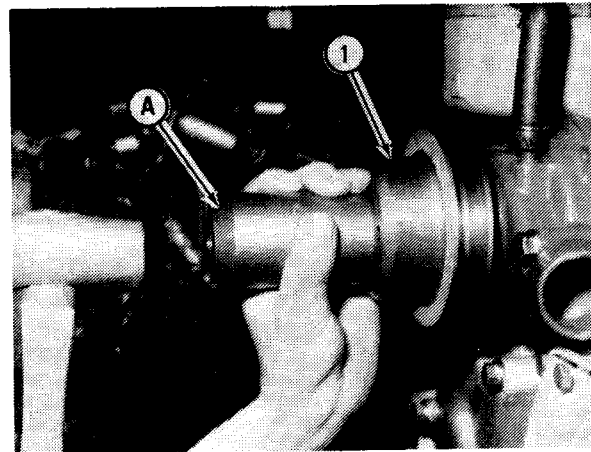

- (b) After driving in the crankshaft pulley, install washer and tighten nut. Then bend the lock washer to lock the nut.

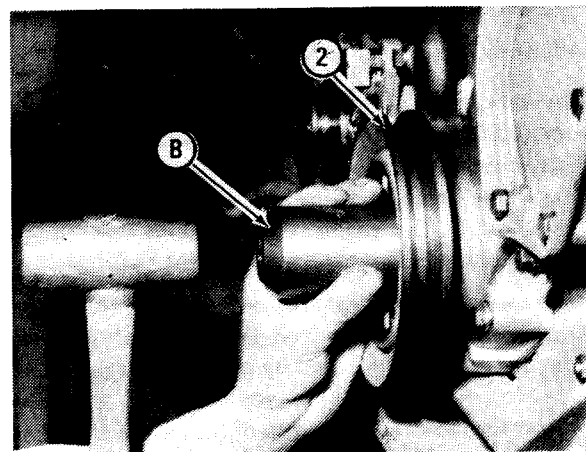

- (21) Install the alternator.
- (22) Install the fan belt as follows:
- (a) Attach fan belt to the pulley.
 - (b) Adjust the fan belt tension in such a way to have a slack of 12 mm (1/2 in.)
- (23) Install the starting motor.
- (24) Install the oil filter.

LUBRICATING SYSTEM

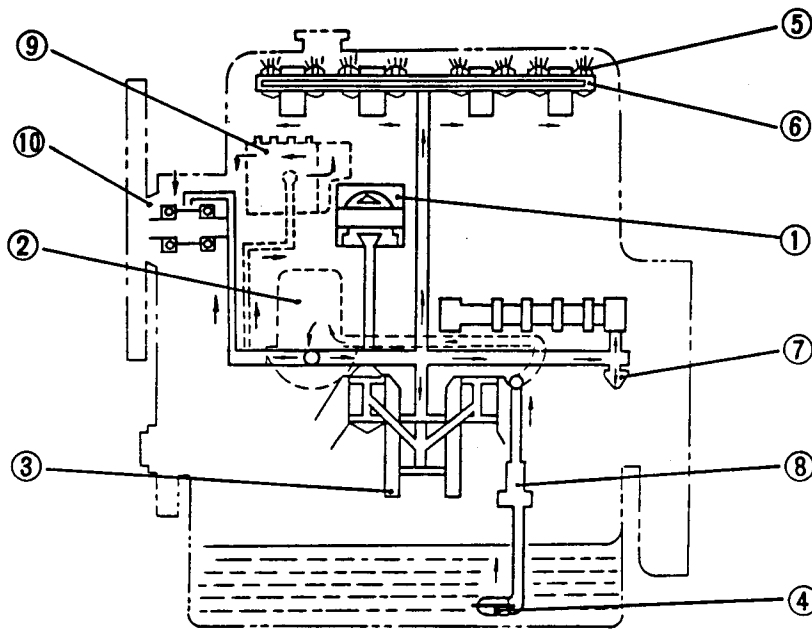

- 1-Piston
- 2-Oil filter
- 3-Crankshaft
- 4-Oil strainer
- 5-Rocker arm
- 6-Rocker shaft
- 7-Oil pressure alarm switch
- 8-Oil pump
- 9-Fuel injection pump
- 10-Water pump

Lubrication oil circuit

1. Lube oil circulation

A trochoid rotary pump draws oil in the oil pan and delivers it under pressure to a full-flow oil filter, from which the cleaned oil is forwarded into the oil gallery inside the crankcase. From the gallery, the oil is distributed to the various parts of the engine. The pump is driven from the camshaft.

The oil filter is of a cartridge type containing a replaceable element through which the oil is forced.

2. Oil pump

The pump is located inside the crankcase at its right-hand rear portion. Its main shaft is driven from the skew gear formed of the camshaft.

2-1 Disassembly

- (1) Loosen bolts securing oil strainer (2) and separate the strainer from oil pump case.
- (2) Loosen bolts (3) securing oil pump cover (4) and separate the cover from oil pump case.
- (3) To facilitate removal of outer rotor (5), turn the pump case upside down
- (4) Drive out pump drive gear taper pin (6) and remove drive gear (7) from main shaft (8). Pull out the main shaft from pump case.
- (5) Drive out inner rotor pin (9) and separate inner rotor (10) from main shaft.

2-2 Inspection

(1) Running clearance between outer rotor and inner rotor

Using a thickness gauge, check the clearance at various positions. If the reading exceeds the service limit, replace both rotors.

Specifications Unit: mm (in.)

Item	Standard	Service limit
Clearance between inner rotor and outer rotor	0.013 ~ 0.15 (0.00051 ~ 0.0059)	0.25 (0.0098)

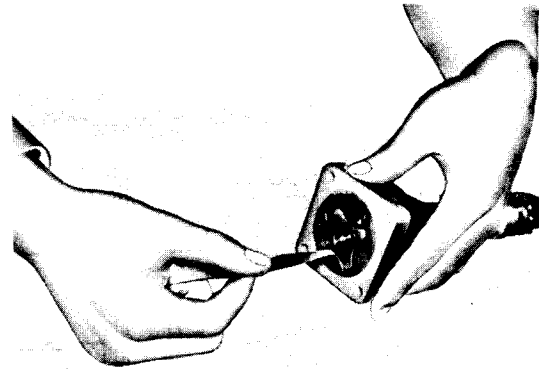

Checking rotor-to-rotor clearance

(2) Sliding clearance between rotors and cover

This clearance is required to be not greater than 0.15 mm (0.00591 in.). If this limit is exceeded, grind off the mating face of the body to reduce the clearance.

Specifications Unit: mm (in.)

Item	Standard	Repair limit
Clearance between rotors and cover	0.04 ~ 0.09 (0.0016 ~ 0.0035)	0.15 (0.0059)

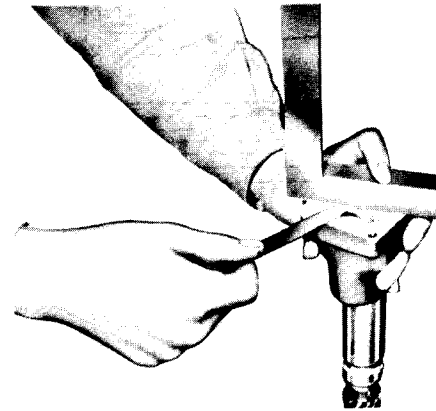

Checking rotor-to-cover clearance

(3) Radial clearance between outer rotor and pump body

Insert a thickness gauge into between outer rotor and body. If the clearance checked is greater than the limit, replace the worn part.

Specifications Unit: mm (in.)

Item	Standard	Repair limit
Clearance of outer rotor in body	0.2 ~ 0.275 (0.0079 ~ 0.01083)	0.50 (0.020)

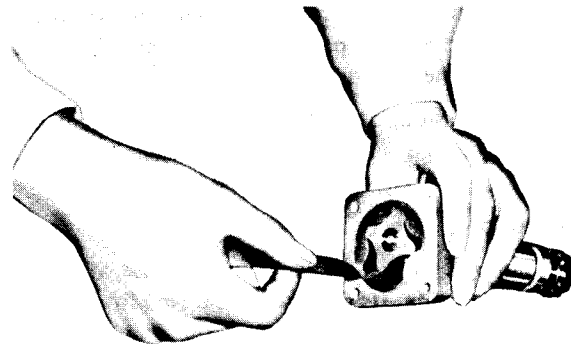

Checking rotor-to-body clearance

(4) Rotor shaft diameter

Inspect the shaft for damage, and check it for wear by miking. Determine the available clearance of the shaft in the pump body from the mike readings; if the service limit in terms of clearance value is exceeded or if the shaft is in badly damaged condition, replacement is necessary.

Specifications Unit: mm (in.)

Item	Standard	Service limit
Rotor shaft diameter	13 ⁰ _{-0.015} (0.5118 ⁰ _{-0.00059})	
Shaft to body clearance	0.032 ~ 0.074 (0.00126 ~ 0.00291)	0.15 (0.0059)

2-3 Reassembly

- (1) Install inner rotor to pump shaft with pin.
- (2) Place pump shaft in pump case. Install pump drive gear to the shaft with pin.
- (3) Place outer rotor in pump case, and install pump case cover complete with gasket and oil strainer.

NOTES

- a) If pump shaft or drive gear has been replaced, a new pin hole must be made by drilling through the gear mounted on the shaft.
- b) After putting on the cover, check to be sure that the match marks are correctly indexed. If the cover is in a wrong position relative to the case, the pump will not draw in oil. Tighten the bolts after checking to be sure that the marks are correctly matched.
- c) After reassembling the pump complete with its strainer, immerse the strainer in a pool of oil and run the drive gear by hand to make sure that the pump is capable of sucking oil in.

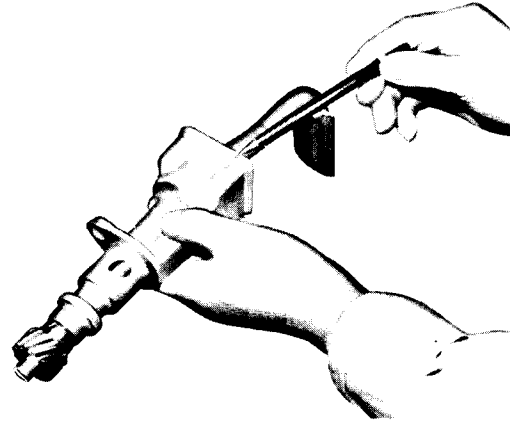

Fitting cover to case by matching marks

3. Oil filter

The filter is mounted on the right-hand side of crankcase at its center part. The oil bypass valve for letting the oil bypass the element is actually a relief valve located in the center portion of the element. This valve is set to open when the differential pressure across the element rises to $1.0 \pm 0.2 \text{ kg/cm}^2$ ($14.2 \pm 2.8 \text{ psi}$); when the valve opens, the oil flows directly from inlet side to outlet side. The filter element must be serviced regularly or before the element becomes so dirty as to actuate this bypass valve.

The oil filter has a built-in relief valve operating in response to the oil pump discharge pressure. This valve starts relieving when the pressure rises to $3 \pm 0.2 \text{ kg/cm}^2$ ($43 \pm 2.8 \text{ psi}$), thereby bleeding the excess oil to the oil pan and limiting the pressure of oil reaching the engine oil gallery to a constant level.

3-1 Disassembly

- (1) Remove filter (1) and relief valve (2) from filter bracket (3).

3-2 Inspection

The filtering element is prescribed to be replaced after each 300 hours of operation or whenever its filtering performance is noted to have deteriorated. Inspect the element to see if it has any signs of rupture or fissure; and if so, replace it by a new one. Visually examine the filter bracket for distortion and cracks.

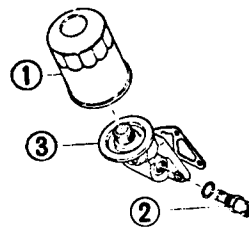

COOLING SYSTEM

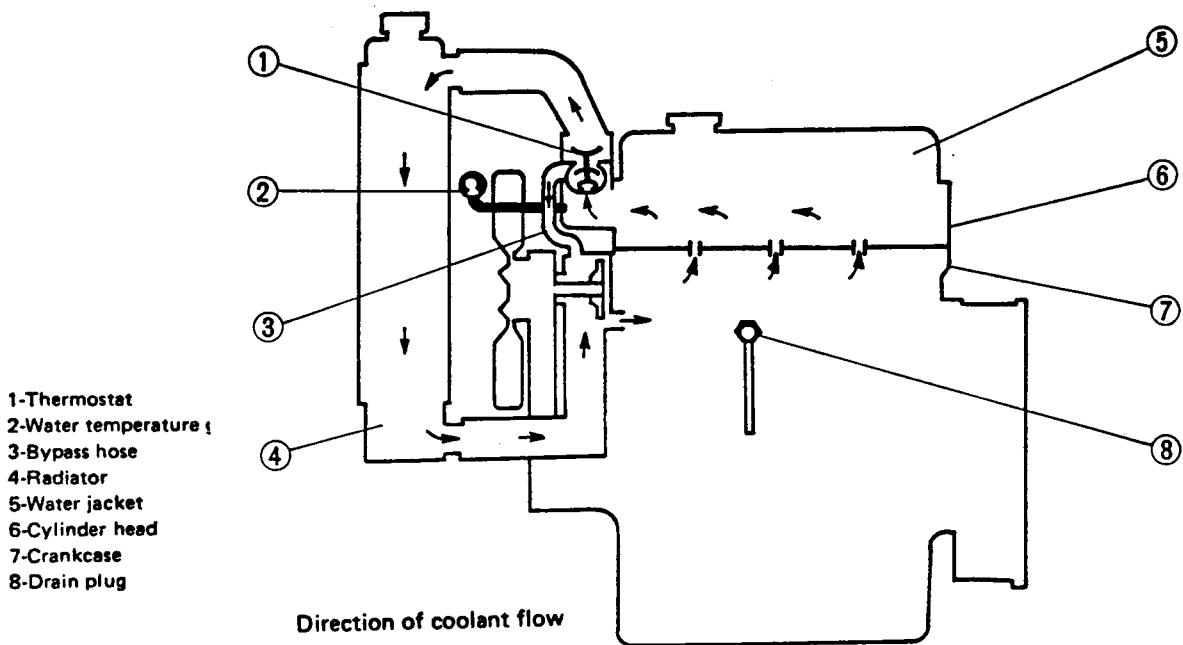

1. Coolant circuit

Referring to the diagram, above, the coolant is set in forced recirculation by the water pump, which is a centrifugal pump driven by cooling-fan belt. The pump draws coolant from the lower tank section of radiator (4) and forwards it to the water inlet of crankcase (7).

As the rising coolant temperature reaches 76.5°C (169.7°F), the thermostat valve begins to open increasingly wide and the coolant begins to flow to radiator (4) at a rising rate of flow, with a corresponding decrease in the amount of coolant being bypassed. As the temperature reaches 90°C (194°F), the valve becomes full open, shutting off the bypass passage.

2. Thermostat

The thermostat is of wax type, designed to start opening its valve at $76.5 \pm 2^{\circ}\text{C}$ ($169.7 \pm 3.6^{\circ}\text{F}$) of rising temperature and opens it fully at 90°C (194°F), lifting it off the seat by 9 mm (0.35 in.).

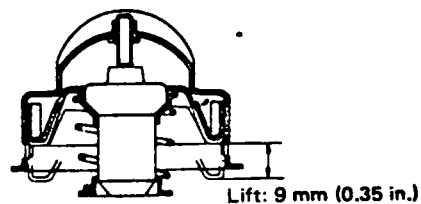

2-1 Disassembly

- (1) Remove thermostat cover (2) by loosening bolts (1).
- (2) Take out thermostat (3).

2-2 Inspection

Clean the thermostat, place it in a hot-water tub, and test it for thermostatic action by heating the tub to raise the water temperature. The valve should start opening at $76.5 \pm 2^\circ\text{C}$ ($169.7 \pm 3.6^\circ\text{F}$) and be fully open at $90 \pm 2^\circ\text{C}$ ($194 \pm 3.6^\circ\text{F}$) with a valve lift of not less than 9 mm (0.35 in.). A thermostat whose valve fails to operate in this manner in the test must be replaced with a new one.

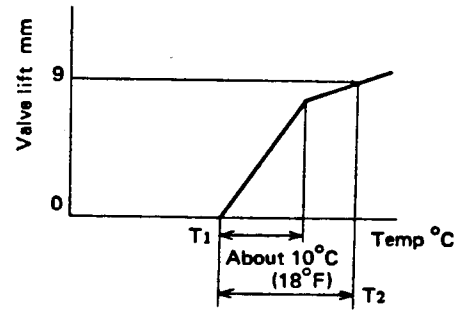

T1 : Temperature [$76.5^\circ \pm 2^\circ\text{C}$ ($169.7^\circ \pm 3.6^\circ\text{F}$)] that makes valve start opening

T2 : Temperature [$90^\circ \pm 2^\circ\text{C}$ ($194^\circ \pm 3.6^\circ\text{F}$)] that makes valve fully open with a lift of not less than 9 mm (0.35 in.)

Thermostat performance curve

3. Water pump

The water pump is of centrifugal type. Its bearings are lubricated by engine oil fed from the main gallery within the crankcase. The impeller is threadedly mounted on the pump shaft.

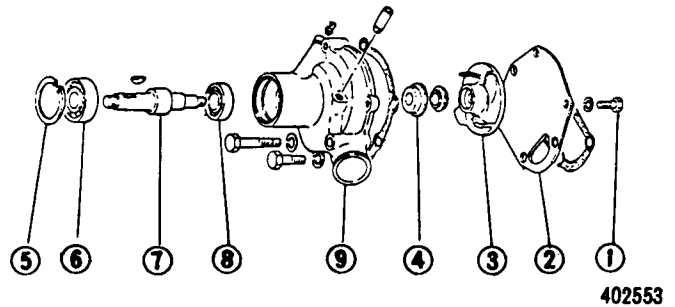

1-Bolt
2-Cover
3-Impeller
4-Unit seal
5-Snap ring

6-Bearing
7-Shaft
8-Bearing
9-Pump case

402553

3-1 Disassembly

- (1) Remove pump cover (2) by loosening cover attaching bolts (1).

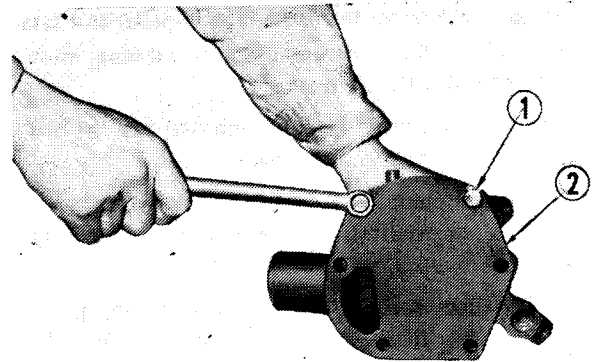

J20270

- (2) Support the shaft with a stand to remove impeller (3).

NOTE

Impeller is threadedly mounted on shaft. The thread is of right-hand screw.

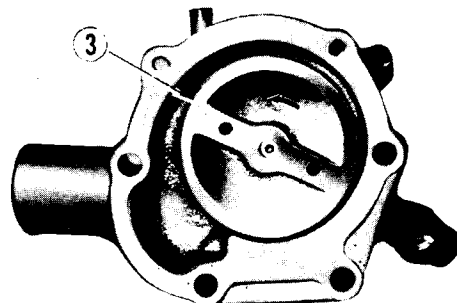

- (3) Remove snap ring (6) from the water pump shaft.

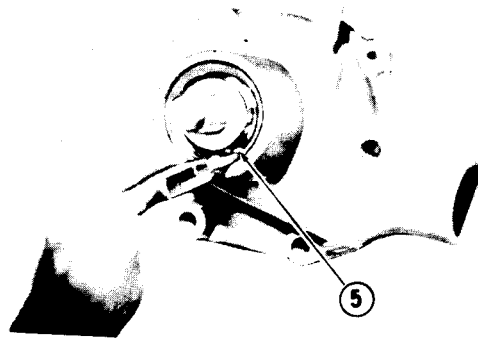

- (4) Pull shaft (8) off the pulley side on pump case and remove bearings (7) and (9) from the shaft.

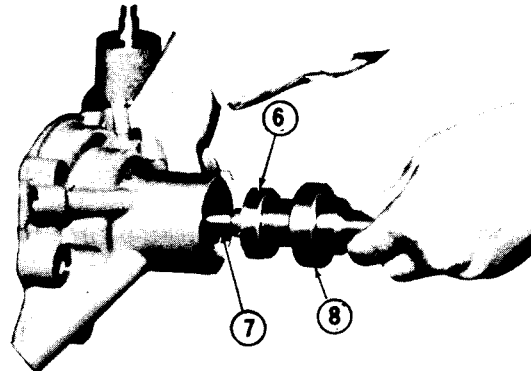

3-2 Inspection

- (1) Examine the pump operation by slowly rotating it. If the pump is erratic in rotation, replace the bearings with new ones.
- (2) Visually check the impeller for corrosion or breakage. Replace a defective impeller. Also check the impeller for signs of rubbing. If such rubbing is evident, check for the cause. The impeller and case or cover, if found damaged due to rubbing, must be replaced with new ones.
- (3) Check the unit seal for condition. Replace the seal if it is badly worn or damaged.
- (4) Check the pump shaft bearing journals for wear. Replace the shaft if the journals are excessively worn.
- (5) Check those surfaces of pump case to which the bearings are fitted for excessive wear or damage. Replace the case or the pump assembly if the case is found in bad condition on those surfaces.

NOTE

Upon assembling the water pump, turn it by means of the pulley, making sure that the pump rotation is smooth without signs of binding.

3-3 Reassembly

- (1) Install bearings (2) on pump shaft (1) and install the shaft in pump case (3).
- (2) Install snap ring (4) in case on pulley side.
- (3) Install unit seal (5) in impeller (6) and secure the impeller to the shaft.
- (4) Install cover (7).
- (5) Rotate the shaft to check to see that the impeller does not interfere with cover.

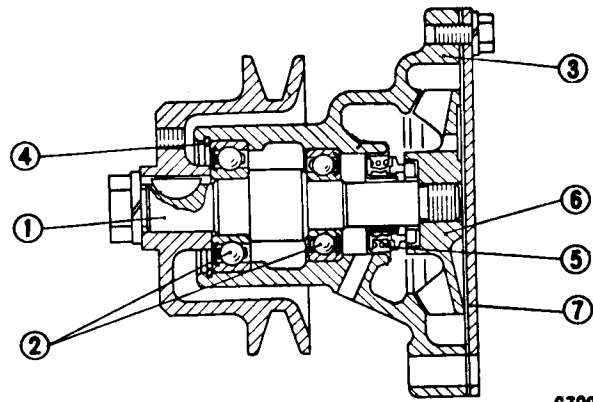

670285

FUEL SYSTEM

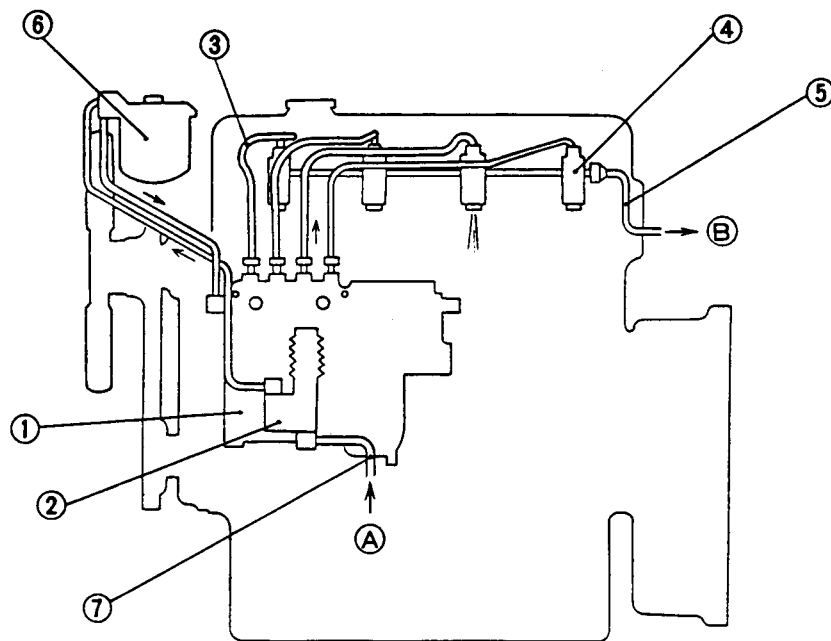

1-Fuel injection pump
2-Fuel feed pump
3-Fuel injection pipe

4-Fuel injection nozzle
5-Fuel leak-off pipe

6-Fuel filter
7-Fuel pipe

Fuel circuit

1. Fuel circuit

The fuel feed pump, mounted on the fuel injection pump body and forming a part of the injection pump unit, draws fuel from the fuel tank and delivers it through the fuel filter to the gallery inside the injection pump.

The injection pump is of individual plunger type, consisting of four plunger pump elements which are driven from a common camshaft. Each pump element delivers, intermittently, a shot of high-pressure fuel oil to its injection nozzle through its own injection pipe. These shots are synchronized to the diesel cycle in each cylinder and timed by the setting of the timing mechanism.

“Injection quantity,” or the amount of fuel delivered uniformly by the four pump elements to the engine through their injection nozzles, is controlled from the accelerator through a linkage and automatically adjusted by the injection pump governor on the basis of engine speed and load requirements.

The governor built in the injection pump body is a mechanical all-speed governor, which limits the maximum and minimum engine speeds and actuates the control rack of the injection pump to maintain a constant engine speed under varying load condition at a speed level proportional to the position of the accelerator.

2. Priming the fuel system

- (1) Unlock the priming pump by turning its knob counterclockwise.
- (2) Loosen the air vent plugs, and operate the pump until overflowing fuel no longer carries air bubbles.
- (3) Tighten the air vent plugs while pressing the pump knob downward.
- (4) Lock the pump by turning the knob clockwise while pressing it downward.

3. Adjusting the injection timing

The engine with RUV governor

- (1) Alignment marks (line marks) are provided on the pump body and flange plate. Make sure that these marks are lined up. With the pump gear and idler properly positioned in their meshed condition inside the timing gear case, that is, the match marks on these gears indexed to each other, mount the injection pump unit on the engine front plate and secure it by tightening the mounting bolts.
- (2) Install fuel feed pipes and lube oil pipe, and reconnect all but No. 1 fuel injection pipe.
- (3) Crank the engine slowly until the plunger in No. 1 pumping element comes to the position for "beginning of injection." Check to be sure that the timing mark on crank pulley is matched to the pointer on the timing gear case; if not, adjust the mounted position of the pump in the following manner:

NOTE

Tilting the pump toward the engine advances the timing, and vice versa. Refer to the graduation marks provided on the edge face of the mounting flange: one division is equivalent to 6 deg. of crank angle.

- (4) Having made sure that all timing marks are matched as prescribed and that the beginning of injection is correctly timed (in reference to No. 1 cylinder), reconnect the injection pipe (No. 1). Prime the fuel circuit in the manner previously described: make sure that no air remains trapped in any part of the circuit.

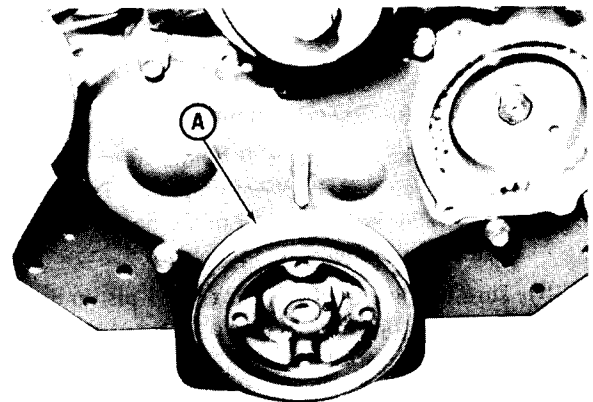
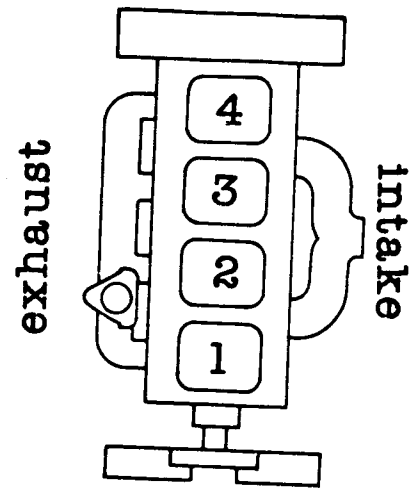

A-Timing mark on crankshaft pulley (TDC)

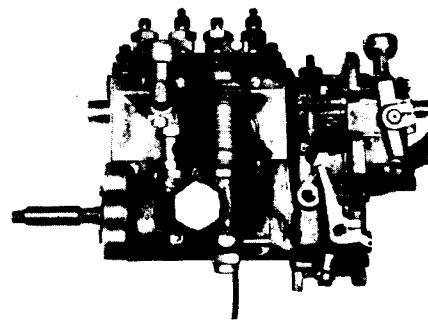

The engine with RSV governor

The injection timing for each model of the engine varies according to its output, speed and specification. Be sure to verify the timing by referring to the specifications of each model.

(1) Bringing No. 1 piston to top dead center on compression stroke

- (a) Using turning bar (30691-11800) at the crankshaft pulley, turn the crankshaft in normal direction (clockwise as viewed from the front side of the engine).
- (b) Stop cranking the engine when the timing mark "0" on the crankshaft pulley is aligned with the pointer.
- (c) Move the intake and exhaust valve rocker arms for the No. 1 cylinder up and down to make sure that they are not being pushed up by their push-rods.

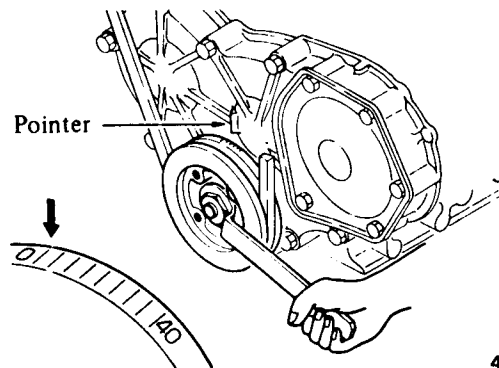

401297

(2) Inspecting fuel injection timing

- (a) Remove the delivery valve holder from No. 1 pumping element of injection pump. Take delivery valve and spring out of the holder, and restore the holder to the pump.
- (b) Turn the crankshaft to bring No. 1 piston to about 60° position before top dead center on compression stroke.
- (c) While operating the priming pump to allow fuel to flow from the delivery valve holder, crank the engine in normal direction. Reduce cranking speed when the fuel just starts to stop flowing. Stop cranking when the fuel stops flowing.
- (d) Make sure that the timing mark on the crankshaft pulley is aligned with the pointer.

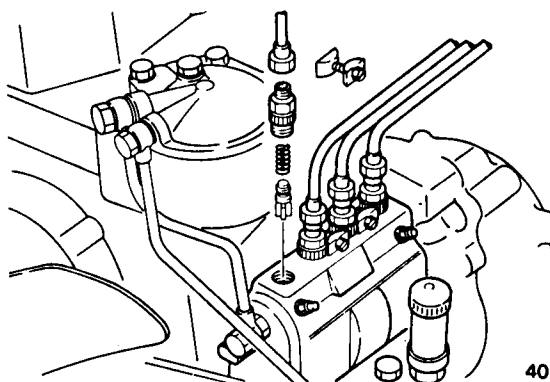

401302

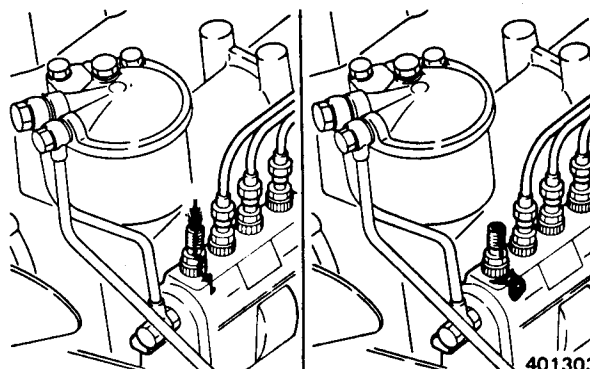

401303

(3) Adjusting fuel injection timing

- (a) If the timing is retarded, tilt the injection pump toward the crankcase. If it is advanced, tilt the pump away from the crankcase.

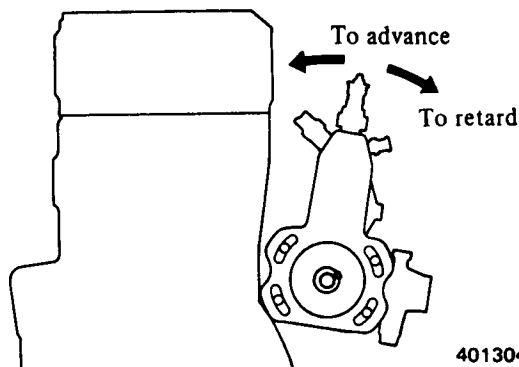

401304

- (b) One graduation of the scale on the injection pump coupling changes the timing by 6° in terms of crank angle.

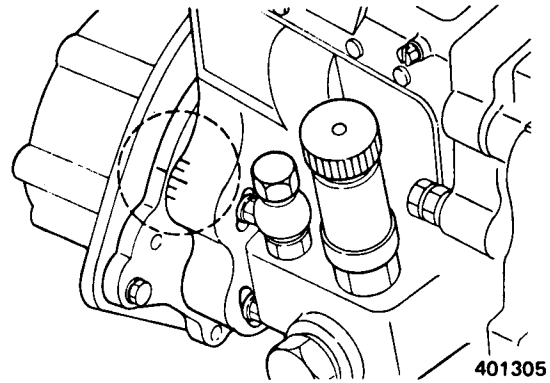

4. Fuel filter

The fuel filter uses a special paper element having high filtering performance and large capacity.

4-1 Inspection

- (1) **Filter case and cover**
Check for cracks, distortion or other damage and also for stripped threads. Replace the case and cover if found in defective condition.
- (2) **Connector bolts and plug**
Check for defective threads, replacing them if damaged.
- (3) **Gaskets**
Discard gaskets removed in disassembly. Be sure to use new gaskets in each reassembly.

NOTE

Do not wash the element for re-use.

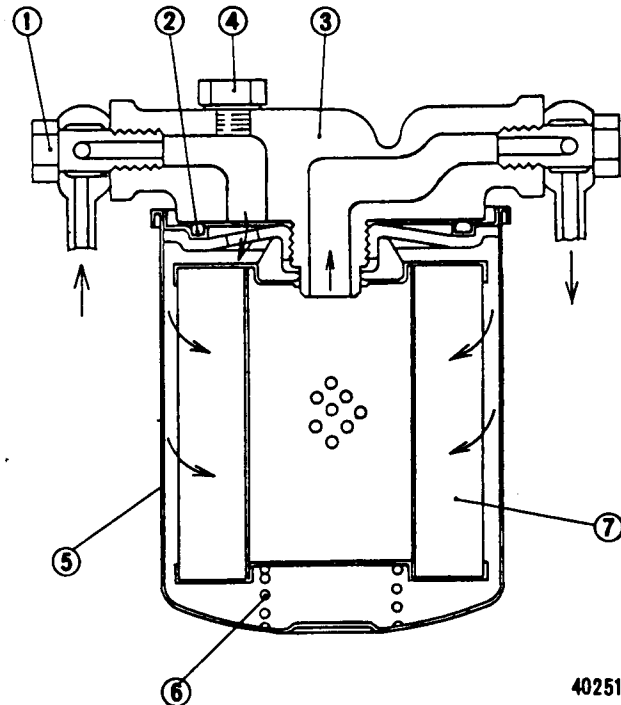

- | | | |
|-----------------|--------------|---------------|
| 1-Bolt | 5-Case | 8-Bolt |
| 2-Gasket | 6-Drain plug | 9-Spring seat |
| 3-Cover | 7-Spring | 10-Element |
| 4-Air vent plug | | |

5. Injection nozzles

The injection nozzle provides a means of spraying into the precombustion chamber the fuel oil delivered under pressure from the injection pump. It sprays oil out in a conical pattern consisting of finely atomized droplets of oil. The mating surfaces of the nozzle holder body, distance piece and nozzle are precision-finished to form an oil-tightness.

The injection pressure adjustment may be made by means of adjusting washer. Increasing the thickness of the washer will increase the spring tension and, hence, the injection pressure, and vice versa.

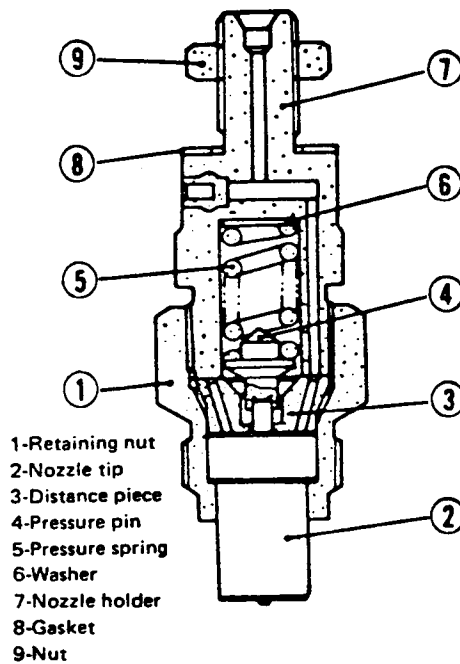

5-1 Removal

- (1) Remove injection pipe connectors (1) to disconnect injection pipes (2).
- (2) Disconnect leak-off pipe (3) (4) connecting nozzles by loosening nuts (5).
- (3) Using a wrench, remove nozzles from cylinder head as shown. Also remove nozzle packings with a wire or screw driver. Replace a defective packing, if any.
- (4) Install injection nozzles in the reverse order of removal. Tighten nozzle holders to a torque of 5 kg-m (36.2 lb-ft).

NOTE

Cover the injection pipe and cylinder head openings to prevent entry of dust or foreign matter after removing the nozzles.

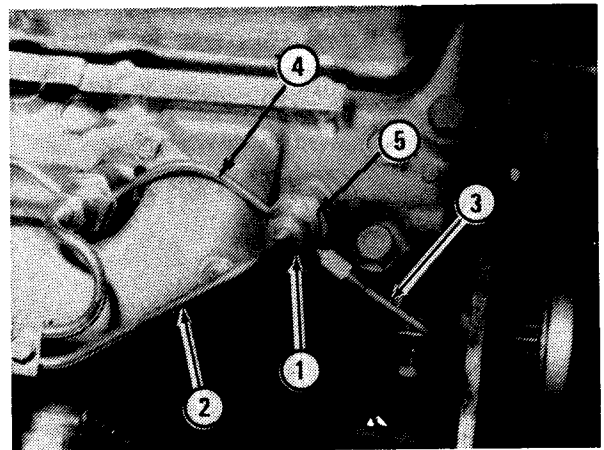

5-2 Disassembly

- (1) Before disassembling injection nozzles, check the nozzle injection beginning pressure, the spray pattern and adjust if necessary. Carry out oil-tightness test and repair if necessary.
Exercise care not to damage the points of needle valves during disassembly, washing and assembly of nozzles.
- (2) Hold retaining nut (1) in a vice and loosen nozzle holder (2) with a wrench.

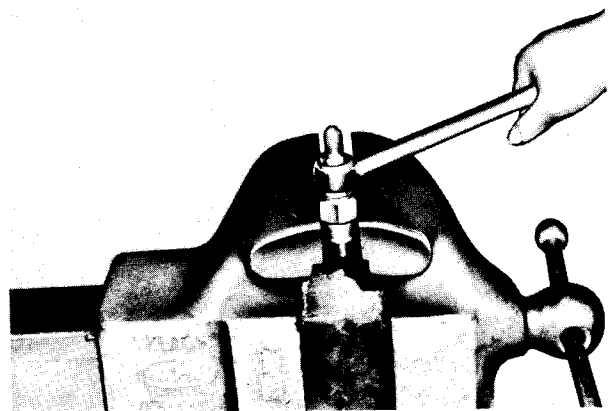

(3) Remove nozzle tip (3), distance piece (4), pressure pin (5), spring (6) and washer (7) from nozzle holder.

(4) All the parts disassembled should be washed in clean kerosene and dried with compressed air. Decarbon the nozzles removed with a wooden scraper and clean them thoroughly in gasoline.

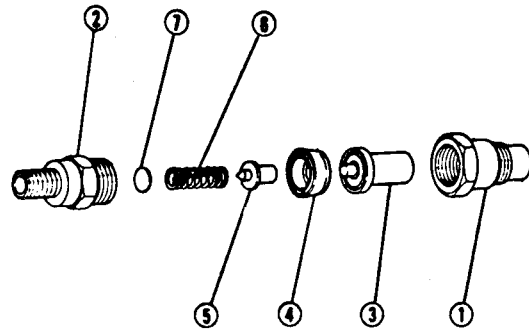

5-3 Inspection

(1) Needle valve and nozzle body

- (a) Immerse needle valve and nozzle body in a pool of clean kerosene, insert the valve into the body, and move the valve back and forth to be sure that the sliding contact is smooth without evidencing any excessive clearance. The injection nozzle as a whole must be replaced if the fit is found defective.
- (b) Visually examine the nozzle body with a magnifying glass having a power of 4 or 5.
- (c) Inspect the needle valve for distortion or damage at its seating part and for wear of its end face in contact with the pressure pin.
- (d) Poor seating contact may be corrected, if the defective condition is not advanced too far, by lapping the valve against the seat with a coat of clean lube oil applied to the seating faces. If this does not help, the injection nozzle must be replaced.

(2) Nozzle holder and distance piece

Check the fit between nozzle holder and distance piece. Determine the quality of the fit from contact patterns obtained with the use of red lead paste: defective fit will be evidenced by an abnormally high rate of return oil (leak-off) flow.

(3) Pressure spring and pressure pin

- (a) Replace any pressure spring broken, cracked or otherwise defective, or out of square. Inspect each spring for these defects.
- (b) Inspect each pressure pin for wear at its end faces, one for pressure spring and the other for needle valve.

(4) Leak-off pipe packing

If the packing is found in deteriorated condition, replace it.

5-4 Testing and adjustment

(1) Injection pressure

The pressure at which the needle valve unseats itself against the force of the pressure spring is referred to as "valve opening pressure" or "beginning-of-injection pressure," but will be called here "injection pressure" for short. The value of this pressure is specified; it is checked and adjusted as follows:

- Install the injection nozzle in the nozzle tester, and operate the manual pumping handle of the tester several strokes to prime the nozzle.
- Move the lever up and down slowly, completing each up-and-down cycle in about a second, to pressurize the injection nozzle, while observing the indication of the test pressure gauge. As the nozzle begins to spray, the indicating pointer of the gauge being deflected will start perceptively oscillating: read the pressure right then as the injection pressure.

Specifications Unit: kg/cm² (psi)

Item	Standard	Repair limit
Injection pressure	120 ⁺¹⁰ ₀ (1706.4 ^{+142.2} ₀)	110 (1564.2), minimum

- If the reading taken is below the limit, increase the thickness of the shim used on the pressure spring. Increasing the shim thickness by 1 mm (0.04 in.) raises the injection pressure by about 10 kg/cm² (142 psi). Adjusting shim stock for this purpose is available in 20 sizes, from 1.0 mm (0.0394 in.) up to 1.95 mm (0.0768 in.) in increments of 0.05 mm (0.0020 in.) each.

(2) Spray pattern

The injection nozzles used in the present engine are of throttle type. Some throttling action takes place when the needle valve begins to unseat, thereby limiting the amount of fuel being sprayed out during the initial stage of each fuel injection. Thus, each slug of fuel sprayed out may be regarded as consisting of two parts: initial throttled spray and terminating main spray.

When tested on the nozzle tester, the injection nozzle can be made to produce these two kinds of spray for visual inspection. Initial throttled spray comes about when the tester lever is operated at a rate of 60 cycles per minute (up and down in one second); terminating main spray occurs when the lever is operated rapidly at a rate of, say, 4 to 6 cycles per second.

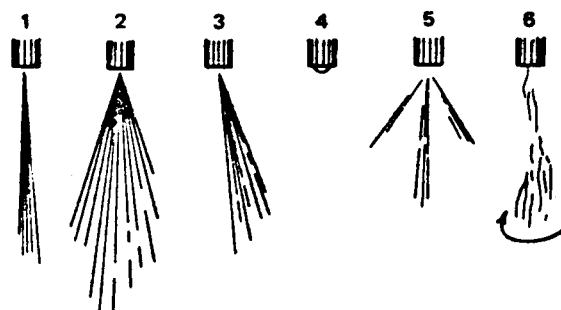
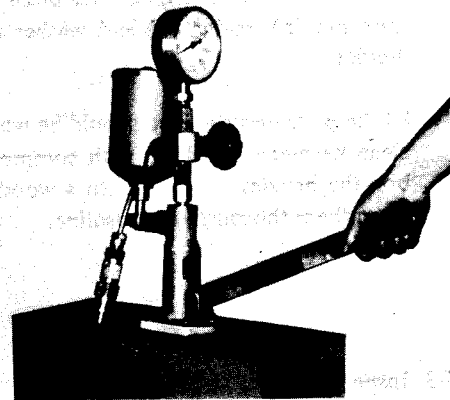

- 1-Good
2-Spray cone too large
3-Off-center spray
4-After-dribble
5-Fissured spray
6-Whirling spray

Possible patterns of spray

(a) Initial throttled spray

When the nozzle is producing only this spray, atomization is generally poor and the pattern is rather straight than conical, there being more or less after-dribble, that is, fuel dribbling after injection. All these are due to the fact that the fuel being injected is being throttled by the pintle protruding from the valve.

While the nozzle is making this spray, see if the needle valve chatters in synchronism with the cyclic motion of the lever; if so, then the needle valve is free from any sticking or hitching tendency and, if not, the nozzle and needle valve must be cleaned by washing and re-tested.

Off-center spray or directionally erratic spray, if noted, should be taken to mean that the injection nozzle needs thorough cleaning.

(b) Terminating main spray

With the tester lever operated at a rate of 4 to 6 cycles per second, the initial throttle spray is hardly visible. The spray under this condition may be regarded as main spray.

The main spray should be a good straight cone, consisting of finely atomized fuel particles without any large droplets, and should terminate with no dribble at the tip, not to mention of any fuel dripping.

(3) Seating tightness

An injection nozzle tested and adjusted as above, and found to produce a good spray pattern may be re-used in the engine provided that it passes this final test — seating tightness test.

With the injection nozzle mounted on the nozzle tester, raise the pressure slowly to 100 or 110 kg/cm^2 (1422 or 1564 psi) (without exceeding the set pressure of 120 kg/cm^2 (1706 psi), so that the needle valve will not unseat). Hold the pressure and observe the nozzle tip: there should be no evidence of fuel oozing out to form a dribble. If such evidence is noted, then the contacting faces of the needle valve and seat must be repaired by lapping in the manner already suggested or the injection nozzle as a whole must be replaced.

5-5 Reassembly

Assemble injection nozzles in the reverse order of disassembly. Be sure to assemble nozzle assembly in kerosene.

When using new needle valves, remove sealing cover (synthetic resin) from the valves and wash them in kerosene to remove rust and corrosion inhibitor sprayed over them by sliding the valves in the nozzles immersed in kerosene.

NOTE

If the needle valve and nozzle proper have to be replaced, be sure to wash the replacement parts in the pool of kerosene after removing their protective film of plastic: wash off the rust-preventive oil from the nozzle proper by stroking the needle valve back and forth in the needle valve stem bore.

6. Fuel feed pump

The camshaft in the bottom section of the injection pump has an eccentric cam besides the cams for actuating the individual pump elements. By this eccentric cam, the pumping plunger of the feed pump is actuated to draw fuel through the inlet strainer and forward it to the injection pump.

A means of manually priming the fuel circuit is provided in this pump. It consists of a plunger and a knob. Pushing the knob in rapid repetition sends the fuel forward. The fuel circuit from the feed pump through the fuel filter to the injection pump can be primed in this manner. This feature is utilized also in bleeding air out of the fuel circuit.

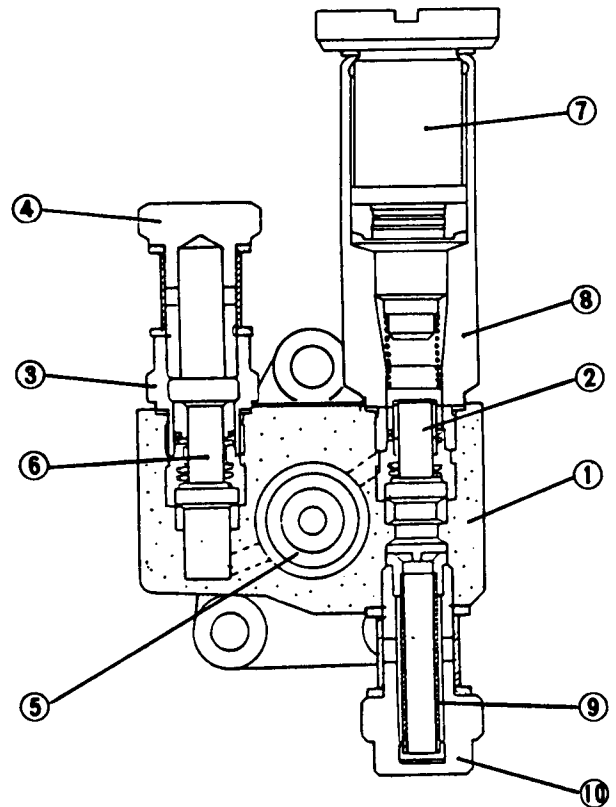

402657

- | | |
|---------------------|-----------------|
| 1-Feed pump housing | 6-Check valve |
| 2-Check valve | 7-Priming pump |
| 3-Valve support | 8-Valve holder |
| 4-Hollow screw | 9-Gauze filter |
| 5-Piston and tappet | 10-Hollow screw |

6-1 Disassembly

- (1) Remove valve holder (1) and priming pump (2) and take out check valve (3). Priming pump cannot be disassembled as the cylinder and valve holder are adhered with adhesives.

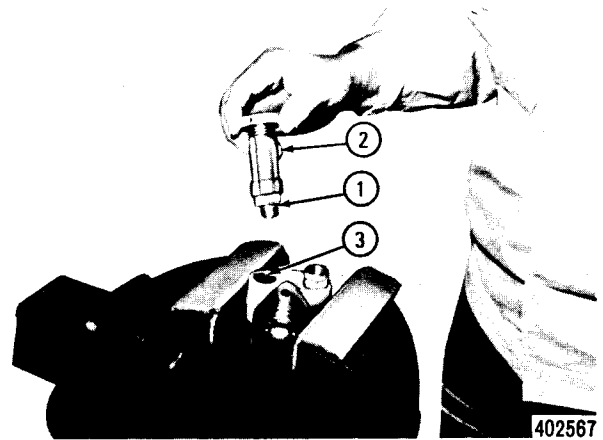

- (2) Loosen piston chamber plug (4) and pull out piston spring (5) and piston (6).

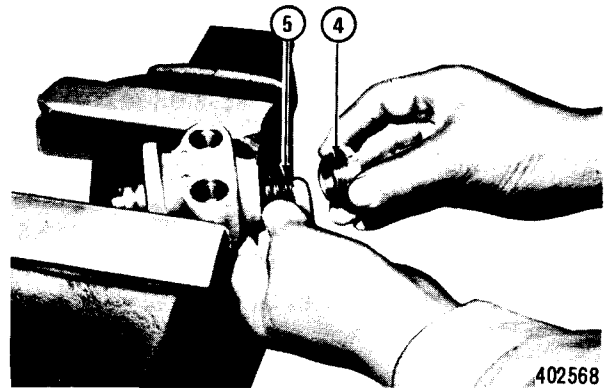

- (3) Remove ring (7) and take out tappet (8) and push rod.

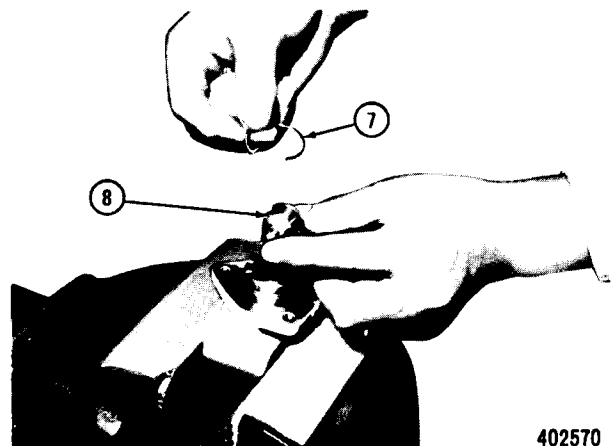
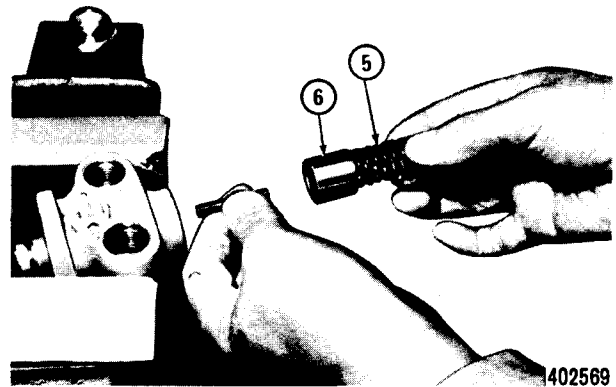

6-2 Inspection

(1) Check valve

Inspect the seating faces of the check valve for wear, and replace parts found in abnormally or excessively worn condition.

(2) Tappet wear

Measure the tappet and tappet hole to determine their diametral wear. Replacement is necessary if the amount of wear noted in comparison with the standard diameter is 0.1 mm (0.004 in.) or more.

Specifications Unit: mm (in.)

Item	Standard	Service limit
Tappet OD	20 (0.78)	0.1 (0.004)
Tappet hole ID	20 (0.78)	0.1 (0.004)

The overall play of tappet roller pin, involving the pin hole and roller, is prescribed to be not greater than 0.3 mm (0.012 in.). If this limit is exceeded, the whole tappet sub-assembly must be replaced.

Replace the roller if its diameter has worn down to the service limit.

Specifications Unit: mm (in.)

Item	Standard	Service limit
Tappet roller OD	15 ⁺⁰ / _{-0.027} (0.591 ⁺⁰ / _{-0.00106})	-0.075 (-0.00295)

(3) Pump housing damage

Inspect the housing for cracks, broken screw threads and other types of damage and repair or replace it as necessary.

(4) Priming pump wear

Inspect the piston and cylinder for scratch marks, wear and rusting. Check the seating faces of its valve for wear. An excessively worn or damaged seating face must be corrected by replacement.

6-3 Testing

The feed pump is in satisfactory condition when it meets all of the test requirements hereunder enumerated:

(1) Suction performance

The pump should be capable of starting to deliver fuel in 45 seconds of its starting at 150 rpm.

(2) Delivery pressure

Run the feed pump at 600 injection-pump rpm, with the discharge side of the feed pump fully closed. Under this condition, the delivery pressure should be anywhere between 1.8 kg/cm² (25.6 psi) and 2.2 kg/cm² (31.3 psi).

Specification

Unit: kg/cm² (psi)

Item	Standard
Feed pump delivery pressure	1.8 ~ 2.2 (25.6 ~ 31.3) at 600 rpm

(3) Capacity test

Run the pump at the speed specified below and open the discharge side more or less to hold the discharge pressure at 1.5 kg/cm² (21.3 psi) (as read on the test gauge), with a measuring glass cylinder set up to receive the discharged fuel. Under this condition, the pump should deliver at least 900 cc (54.9 cu in.)/minute.

Specifications

Item	Standard	Repair limit
Feed pump capacity	900 cc (55 cu in.)/minute, minimum at 1000 rpm	600 cc (37 cu in.)/minute, at 1000 rpm

(4) Air-tightness

Immerse the feed pump in a pool of fuel, with its discharge side plugged up. Apply an air pressure of 2 kg/cm² (28 psi) to its suction to see if any bubbles come out of the pump. Some air, however, will leak out through the clearance between its pushrod and housing. The pump is sufficiently air-tight if the amount of this leakage (with no leakage from any other part of the pump) is not greater than the value specified.

Specification

Item	Standard
Feed pump air-tightness	Not greater than 50 cc (3.1 cu in.)/minute (with bubbles not larger than 2 mm (0.08 in.) in size)

If the air-tightness is poor, replace the pump housing sub-assembly (including housing, push rod and oil seal).

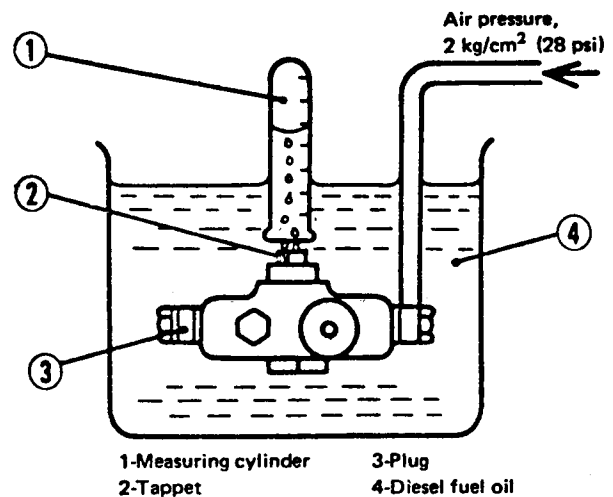

7. Fuel injection pump

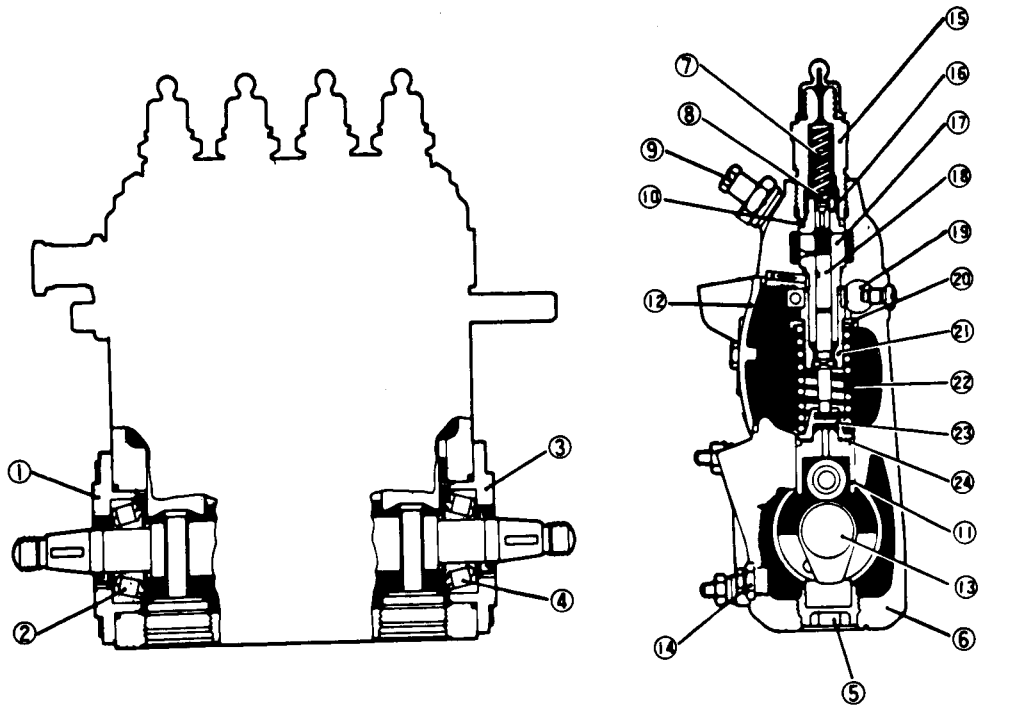

- | | | | |
|--------------------------|-------------------------------|--------------------------|----------------------|
| 1-Bearing cover | 7-Delivery valve spring | 13-Camshaft | 19-Control rack |
| 2-Tapered roller bearing | 8-Delivery valve | 14-Drain plug | 20-Upper spring seat |
| 3-Governor housing | 9-Air vent screw | 15-Delivery valve holder | 21-Control sleeve |
| 4-Tapered roller bearing | 10-Delivery valve seat gasket | 16-Delivery valve seat | 22-Spring |
| 5-Screw plug | 11-Tappet | 17-Cylinder | 23-Lower spring seat |
| 6-Pump housing | 12-Cover | 18-Plunger | 24-Shim |

The pump body is an aluminum alloy casting and houses all the moving parts of pump elements and the camshaft. The governor housing is attached to one end of the pump body.

The camshaft is supported by two tapered roller bearings. Like the engine camshaft, it has four cams, one for each pump element, and is driven from the crankshaft through a train of gears arranged for a gear ratio of 2 to 1. For each two rotations of crankshaft, the injection pump camshaft rotates once.

The pump element consists of a plunger, barrel (cylinder), tappet, plunger spring, control pinion and spring-loaded delivery valve. The tappet rides on the cam and pushes the plunger upward for each rotation of camshaft. As the plunger rises, the fuel in the barrel becomes compressed and is forced out through the delivery valve into the injection pipe. The upward plunger stroke, effective in compressing or pressurizing the fuel, is variable, and is varied by means of the control rack and pinion in the manner to be explained later.

The delivery valve, through which a shot of fuel is forced out into the injection pipe by each upward motion of the plunger, is essentially a check valve having a special function of quickly reducing the line pressure the moment the plunger begins to descend. This quick relief of line pressure is necessary to prevent the injection nozzle from dribbling at the end of each injection. How this is accomplished will become clear.

Tabulated data

Cam lift	8 mm (0.315 in.)
Plunger diameter	6.5 mm (0.256 in.)
Delivery valve dia.	6 mm (0.236 in.); retraction volume 51 mm ³ (0.003 cu in.)/stroke
Injection order	1 - 3 - 4 - 2
Injection interval	90° ± 30'

8. Governor

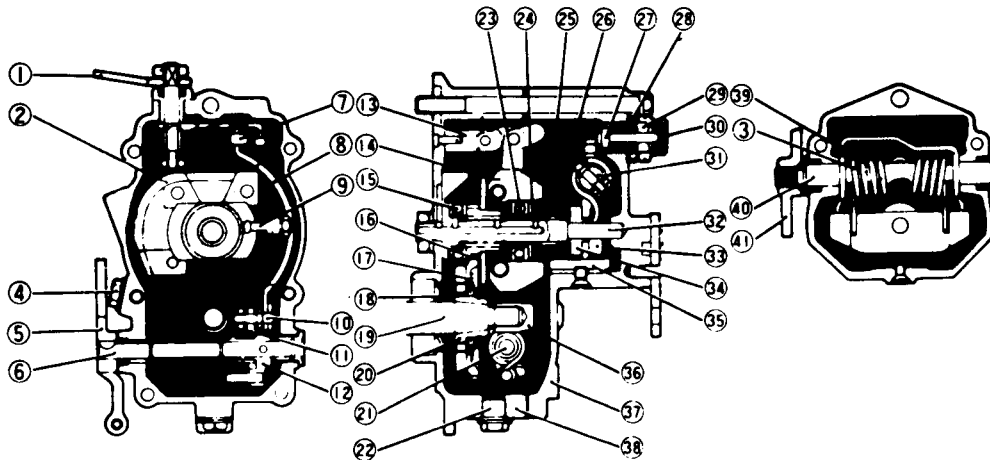

- | | | | |
|-----------------------|------------------------|--------------------|-------------------------|
| 1-Stopper lever | 12-Arm | 22-Drain plug | 32-Governor shaft |
| 2-Oil inlet | 13-Shackle | 23-Bearing | 33-Spring seat |
| 3-Control spring | 14-Flyweights | 24-Shim plate | 34-Spring seat |
| 4-Screw plug | 15-Bearing | 25-Governor sleeve | 35-Torque control lever |
| 5-Stopper | 16-Governor gear | 26-Adaptor spring | 36-Round nut |
| 6-Control lever shaft | 17-Slip disc | 27-Adaptor | 37-Governor cover |
| 7-Shackle pin | 18-Shim plate | 28-Torque spring | 38-Governor housing |
| 8-Floating lever | 19-Camshaft | 29-Adjusting nut | 39-Torque control lever |
| 9-Connecting pin | 20-Camshaft bushing | 30-Cap nut | 40-Shaft |
| 10-Connecting bolt | 21-Control lever shaft | 31-Shaft | 41-Adjusting lever |
| 11-Supporting lever | | | |

The governor is an all-speed governor operating in response to changes in engine speed to actuate the control rack in order to maintain engine speed at a constant level proportional to the set position of the accelerator. This governor function is in sharp contrast to that of a minimum-speed maximum-speed governor, whose control action is to limit the lowest and highest speeds of the engine, leaving the control of intermediate speeds to the operator.

The construction of the governor is as illustrated in the figure above:

The governor consists essentially of governor gear ⑩, flyweights ⑭, governor sleeve ⑮ and speed control spring ③.

The governor gear is mounted on camshaft bushing ⑳ attached to the rear end of the injection pump camshaft with round nut ⑳ and is pressed by slip disc ⑰, so that it is not damaged even when the engine output torque varies.

The flyweights are mounted on governor shaft. The radial movement of the flyweights due to centrifugal force is transmitted to arm ⑫ to push governor sleeve ⑮ through thrust bearing. To this sleeve is attached adaptor spring ⑲. This spring opposes the force of control spring ③ through spring seat so as to compensate for a decrease in torque when the engine is running at low speeds. Floating lever ⑧ is hinged at its lower end to supporting lever ⑪ mounted on control lever shaft ⑥ and is connected at its upper end to control rack through shackle ⑬. To the mid-part of this floating lever is fitted connecting pin ⑨ through which the movement of the flyweights is transmitted to the control rack. Damper spring, which is mounted on the end of control rod, serves to prevent engine hunting as when the engine speed is suddenly decreased. Stopper lever ① is provided to move the control rack to "stop" position.

Engine stalling, which may often occur when the load is suddenly increased, is prevented by torque spring. The timing mark provided on the camshaft bushing and the timing pointer on the governor housing are conveniently utilized in determining the beginning of injection in the No. 1 cylinder during assembly job.

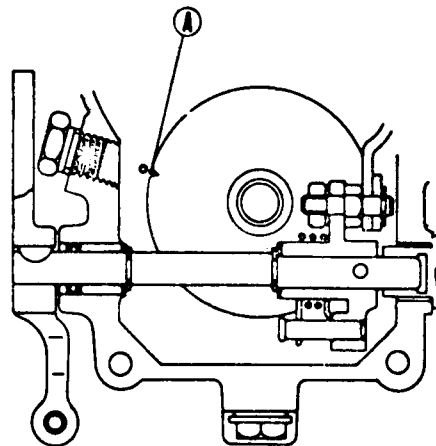

A-Timing mark

Timing mark on injection pump

ELECTRICAL SYSTEM

1. General

	Model	Manufacturer
Starter	M002T54172	Mitsubishi Electric
Alternator	A001T25070	Mitsubishi Electric
Glow plugs	Sheathed type	Hiyoshi Electric

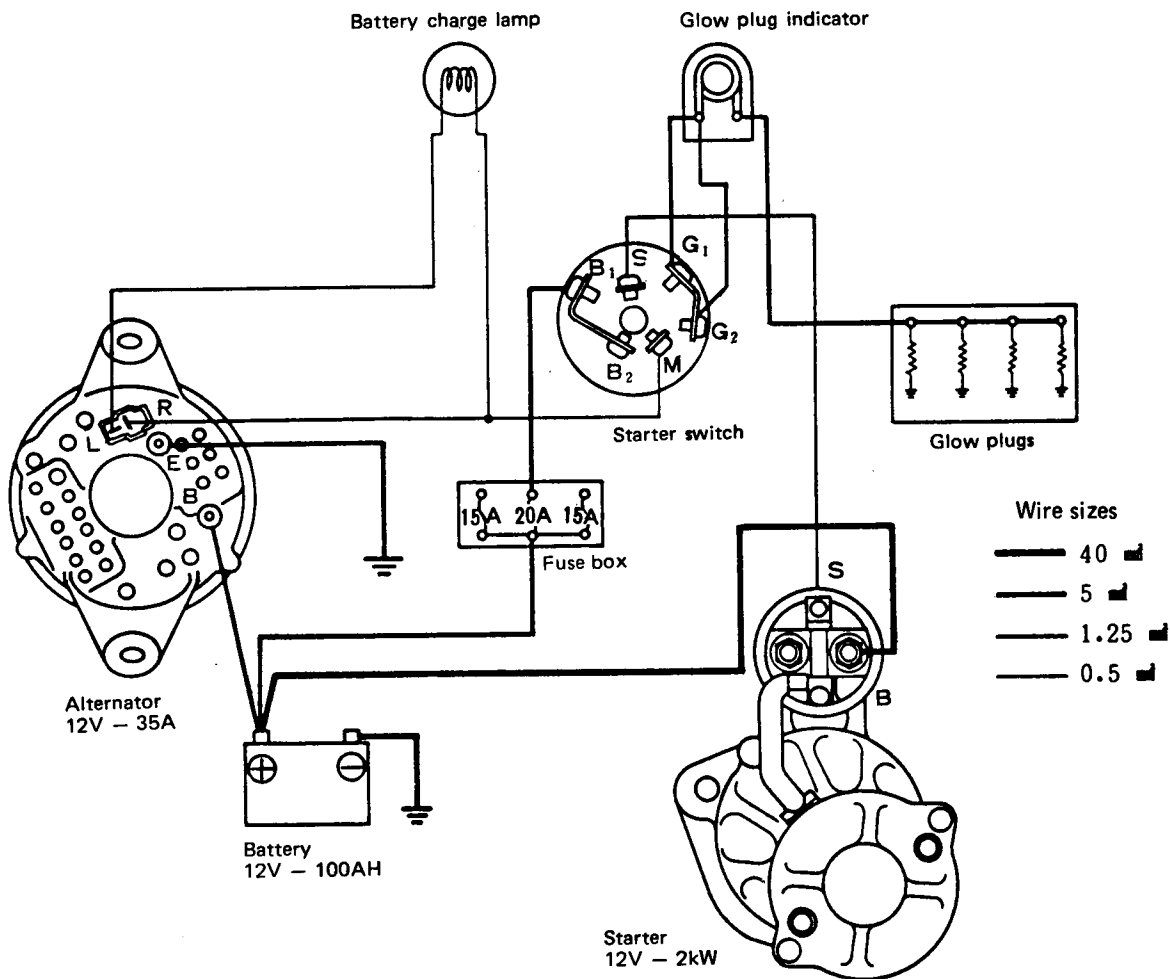

Wiring diagram

1-1 Starter

(1) Tabulated data

Model	M002T54172
Type	Pinion-shift type with overrunning clutch
Voltage	12V
Output	2 kW
Armature winding	Series
Yoke diameter	80 mm (3.15 in.)
Rating	30 seconds
Rotation	Clockwise as viewed from pinion side
Weight	5.8 kg (12.8 lb), approx.

Performance item	Condition	Specification	
No-load characteristics	Voltage: 11 V	Current Speed	130 A, max. 4000 rpm, min.
Locked characteristics	Voltage: 3 V	Current Torque	1000 A, max. 2.8 kg-m (20.3 lb-ft), min.
Switch-in voltage		8 V, max.	

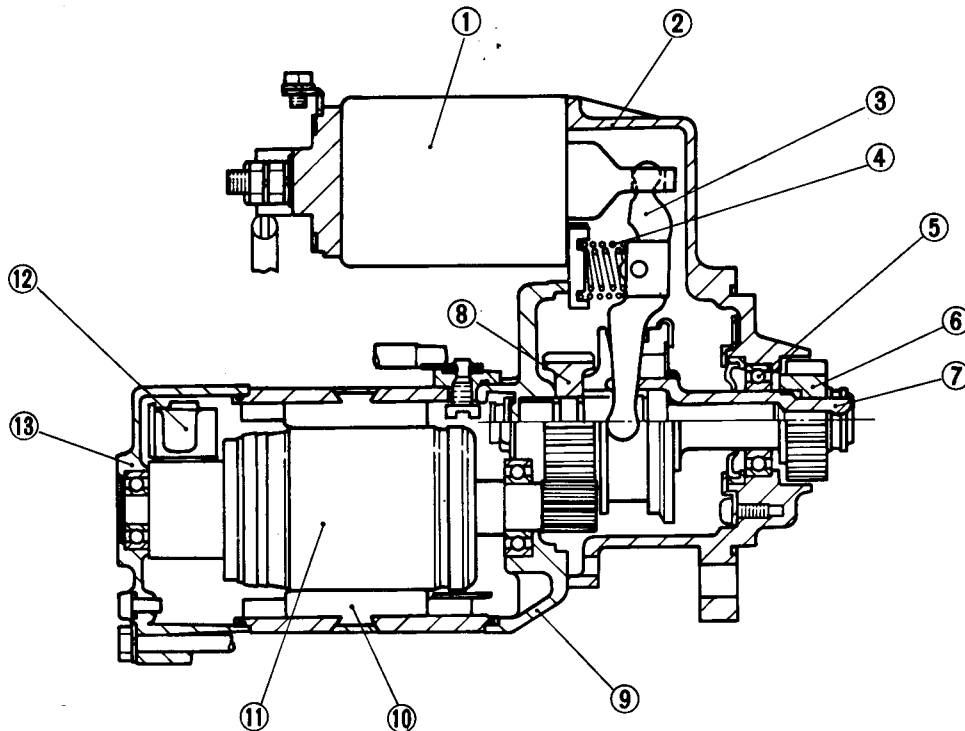

1-Switch assembly
2-Front bracket
3-Lever assembly
4-Spring set
5-Bearing
6-Pinion
7-Pinion shaft

8-Gear
9-Center bracket
10-Yoke
11-Armature
12-Brush holder
13-Rear bracket

(2) Reduction gear train and overrunning clutch

The inner end of armature shaft carries a drive gear which is in mesh with a driven gear splined to the pinion shaft to provide speed reduction. The pinion shaft is fitted loosely to the outer race of overrunning clutch through helical spline engagement. The pinion is fitted to the sleeve – the inner race of the clutch – and held in place by a snap ring.

Five clutch rollers are fitted between the outer race (thrust splines) and inner race (sleeve) of overrunning clutch, each being pressed against the cam face internally formed of the outer race by a spring.

Thus the drive or torque is transmitted from the armature shaft through the reduction gears, pinion shaft, thrust splines (clutch outer race), rollers and sleeve (clutch inner race) to the pinion.

(3) Overrunning clutch operation

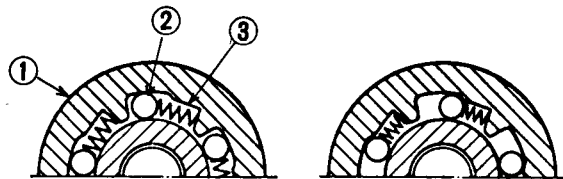
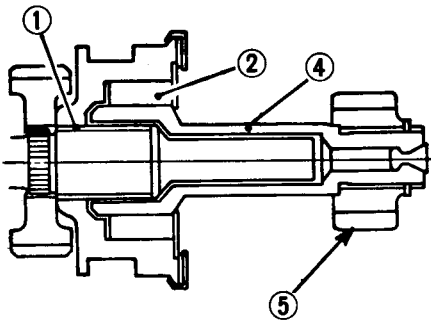

Pinion meshed in flywheel

Engine starts

- | | |
|--------------|--------------|
| 1-Outer race | 4-Inner race |
| 2-Roller | 5-Pinion |
| 3-Spring | |

(a) Pinion meshed in flywheel

As the outer race rotates, the rollers are jammed tight between the inner and outer races to lock these races. Now the torque from the armature is transmitted from the outer race to the inner race and then to the pinion.

(b) After the engine starts, it spins the pinion (inner race) faster than outer race. The rollers are ro-

tated into the free state by the springs to unlock the inner and outer races. This allows the pinion to spin independently of, or overrun, the remainder of the clutch.

(4) Starter operation

(a) Starter switch (SW) in OFF position

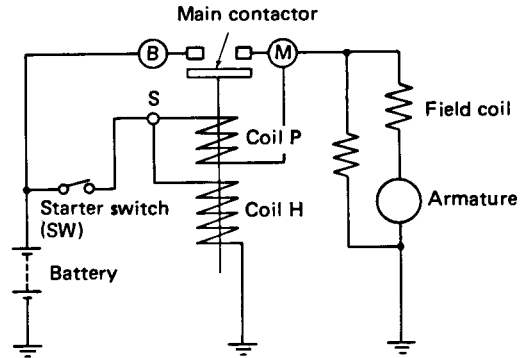

(b) Starter switch (SW) turned to ON position

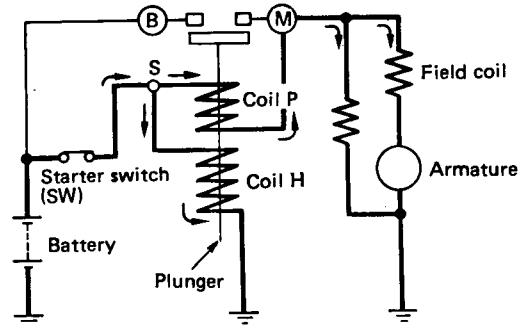

The plunger is pulled. This allows the lever to push the pinion into mesh with the flywheel ring gear. Now the starter begins to crank the engine.

(c) Starter switch (SW) in ON position (with contactor closed)

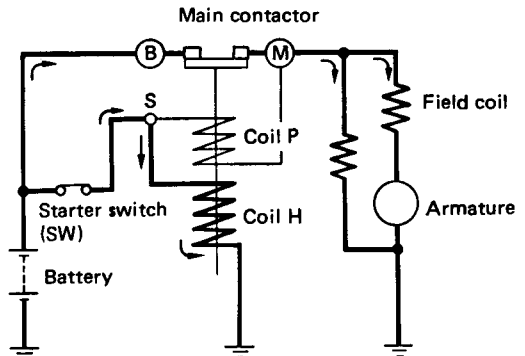

A large current flows into the motor. The starter now cranks the engine with full force while picking up speed at the same time.

1-2 Alternator

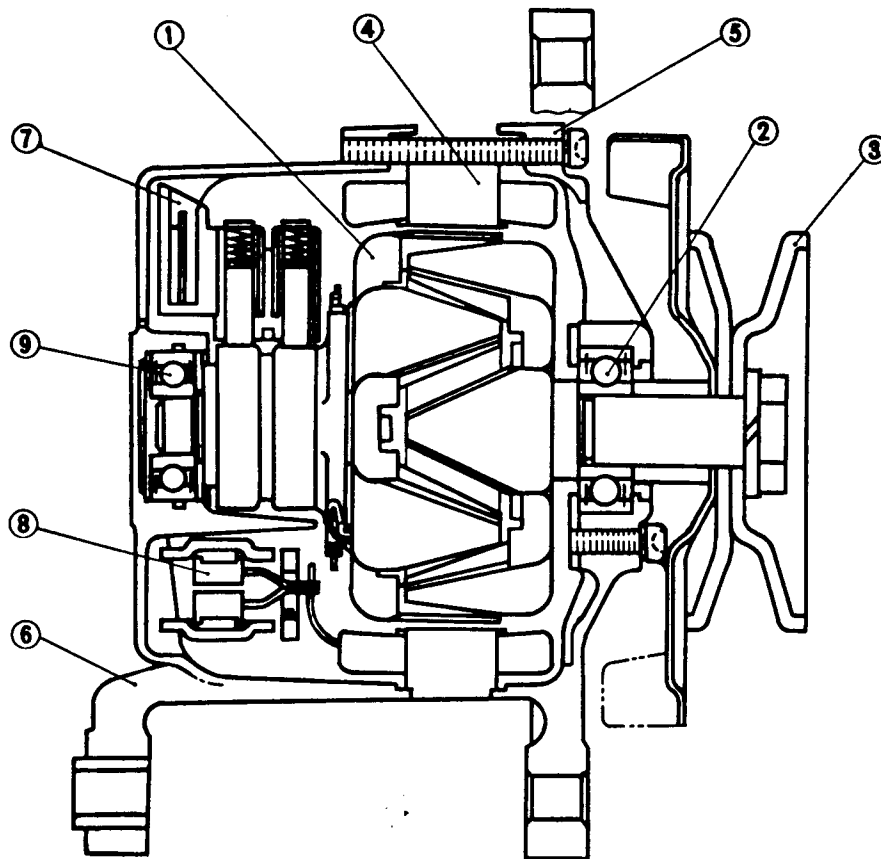

- | | | |
|-----------|-----------------|----------------|
| 1-Rotor | 4-Stator | 7-IC regulator |
| 2-Bearing | 5-Front bracket | 8-Rectifier |
| 3-Pulley | 6-Rear bracket | 9-Bearing |

(1) Tabulated data of alternator

Model designation	A001T25070
Nominal output	12 V – 35 A
Polarity of ground	Negative
Outside diameter	114 mm (4.48 in.)
Direction of rotation	Clockwise as viewed from pulley side
Weight	3.4 kg (7.5 lb)
Regulator	IC type
Voltage regulation	14.4 ± 0.3 V

(2) Construction of alternator

This alternator has a built-in IC regulator. The rotary parts are: rotor, ball bearings, fan and pulley. The stationary parts are: stator, front bracket and rear bracket.

The rectifier consists of a total of six diodes: three diodes on the positive side are mounted on the heat sink and the other three on the negative side are mounted on the rear bracket.

(3) Alternator operation

(a) Starter switch in M position

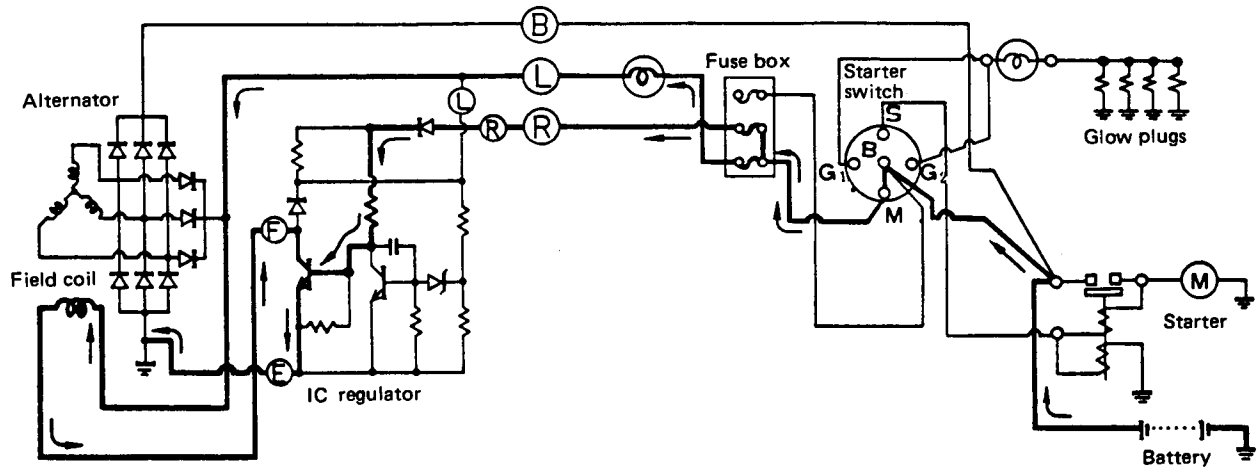

(b) Starter switch in S position and starter operates

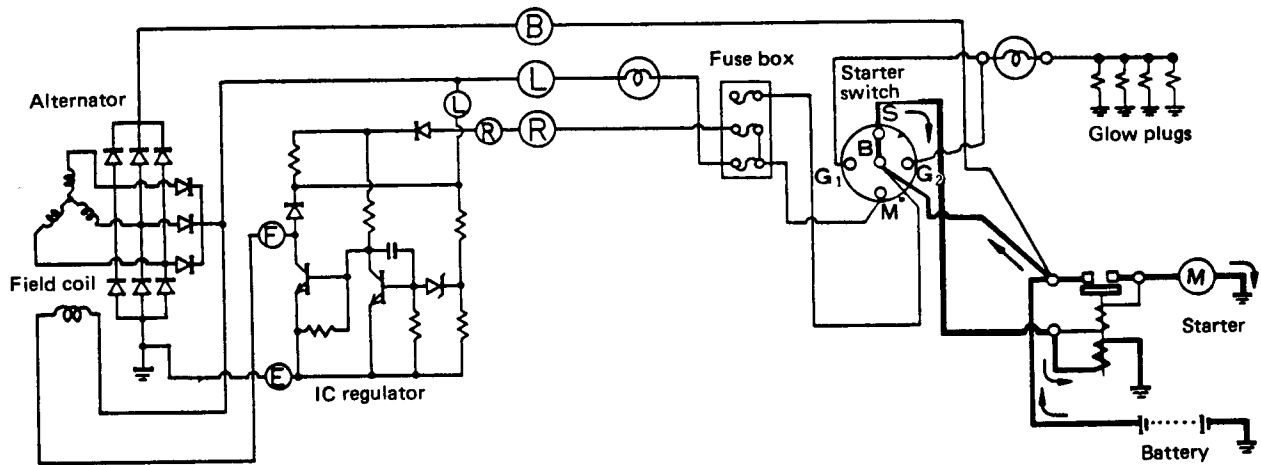

(c) Engine starts and alternator charges battery

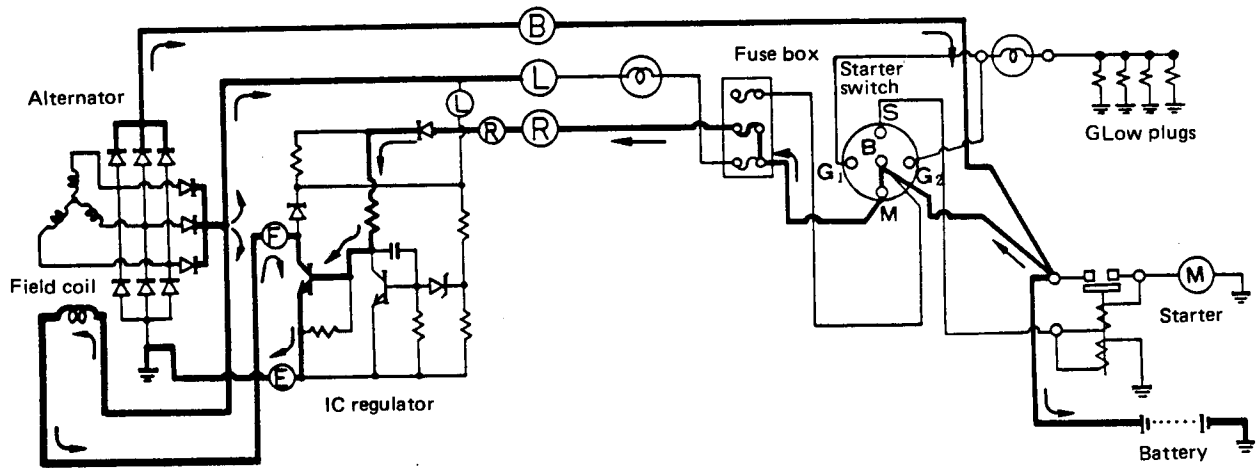

(d) Alternator charges battery excessively

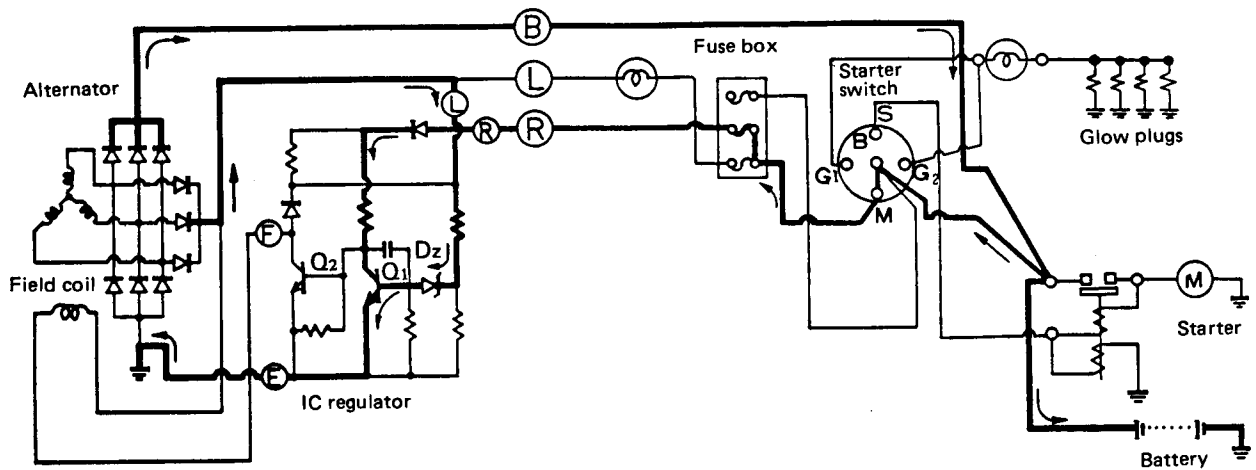

As alternator output voltage rises higher than the regulated voltage, zener diode DZ permits the current to flow to the base of transistor Q₁. As transistor Q₁ turns on, the current flows from the three diodes to transistor Q₁, causing transistor Q₂ to turn off. Under this condition, the field current is reduced to weaken excitation of the rotor and, consequently, output voltage begins to fall.

When output voltage has sufficiently dropped, zener diode DZ permits no current to flow. Now transistor Q₁ turns off and transistor Q₂ turns on and, consequently, the field current increases and output voltage rises again. This process is endlessly repeated to keep output voltage at a virtually constant level.

2. Starter removal and installation

- (1) Disconnect wire (1) between the battery and starter and wire (2) between the starter and starter switch.
- (2) Unscrew mounting nuts (1), and remove starter assembly (2) from the engine. To install, follow the reverse of removal procedure.

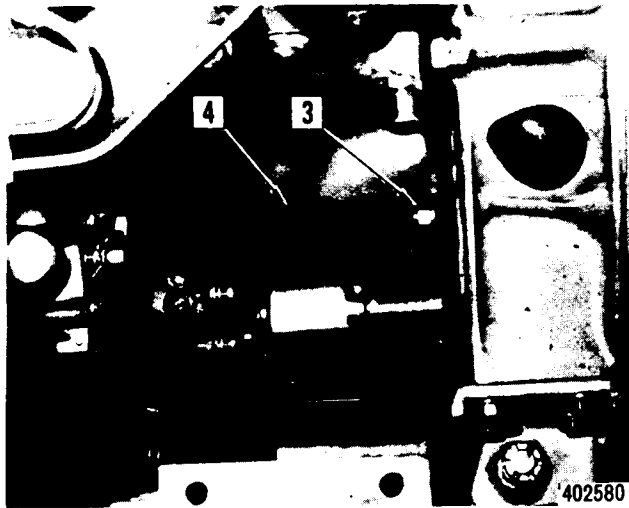

- 1-Nut and washer (2 pcs each)
2-Starter assembly

3. Starter disassembly and reassembly

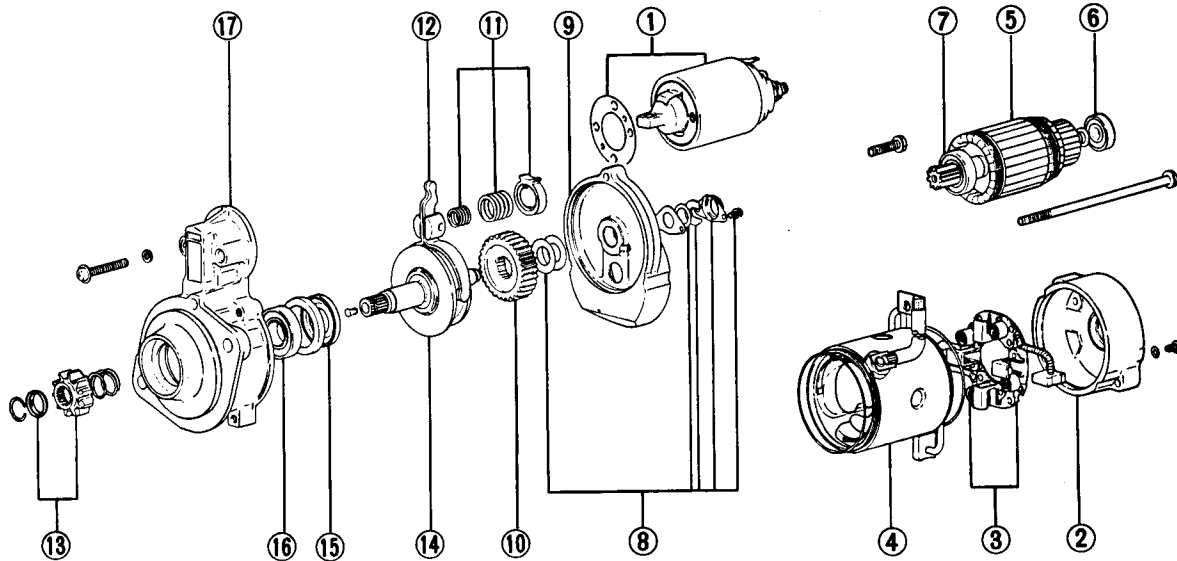

- | | |
|------------------|------------------|
| 1-Switch | 10-Gear |
| 2-Rear bracket | 11-Spring set |
| 3-Brush holder | 12-Lever |
| 4-Yoke | 13-Pinion set |
| 5-Armature | 14-Pinion shaft |
| 6-Ball bearing | 15-Oil seal |
| 7-Ball bearing | 16-Ball bearing |
| 8-Cover set | 17-Front bracket |
| 9-Center bracket | |

(The parts are numbered in the sequence of removal for disassembly. To reassemble, follow the reverse of disassembly procedure.)

(1) Loosen the nut on the switch terminal (M), and remove the connector. Remove the switch by pulling the screws (2 pcs).

(2) Pull the through bolts (2 pcs), remove the brush holder screws (2 pcs) and remove the rear bracket.

NOTE

Take care not to drop the washers which are used in the rear bracket.

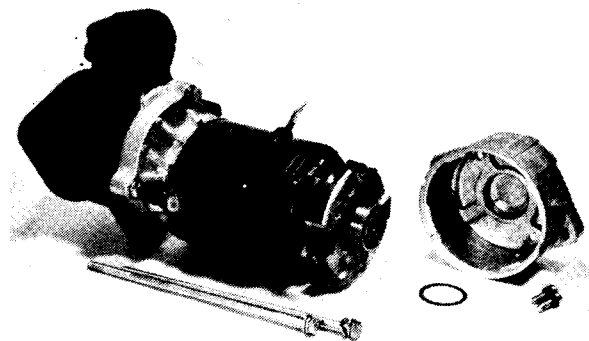
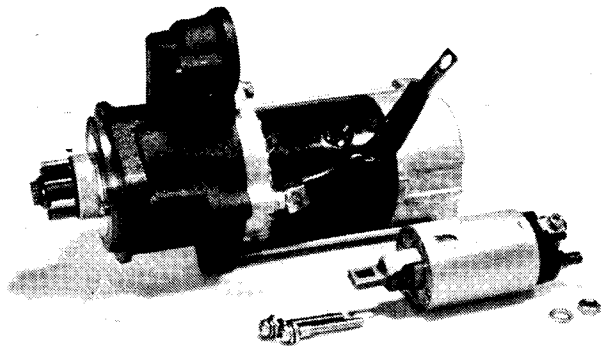

- (3) Remove two brushes on the positive side, and take off the brush holder.

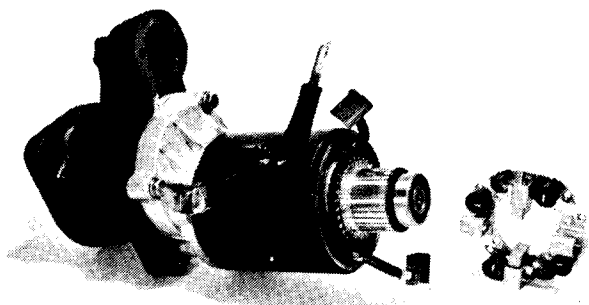

- (4) Remove the yoke, and pull off the armature.

NOTE

Replace rubber packings fitted to the ends of yoke with new ones. Check and record the position of locating notch for the yoke.

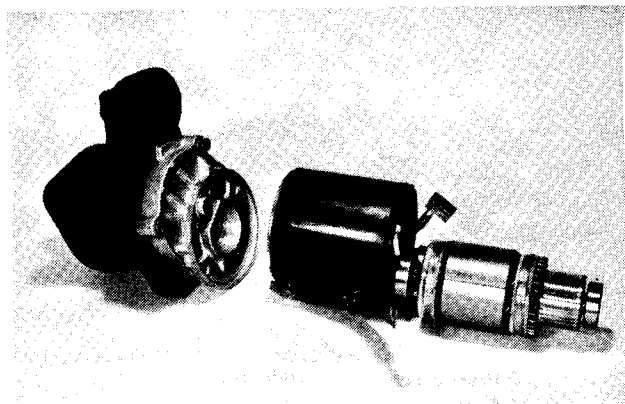

- (5) Remove the cover, and take off the washer and snap ring.

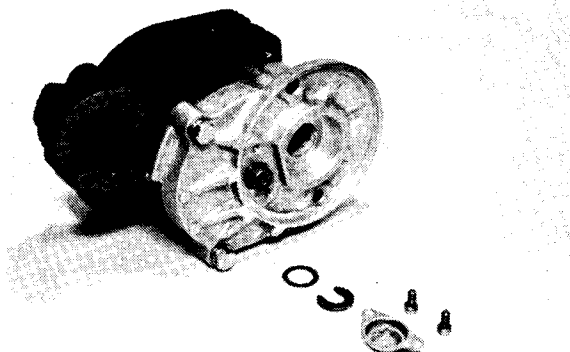

- (6) Remove the center bracket by unscrewing two bolts. Remove washers (several pieces) for adjusting the pinion shaft axial play.

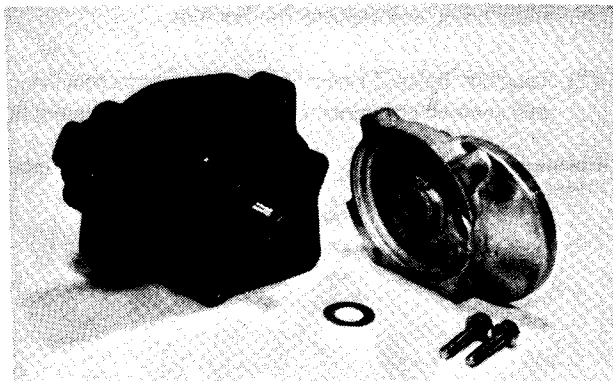

- (7) Remove the snap ring holding the pinion, and remove the pinion.

- (8) Remove the lever springs (large and small), lever, reduction gears, pinion shaft, etc.

NOTE

Lay the lever and springs in the order removed so that they can be restored to their original positions.

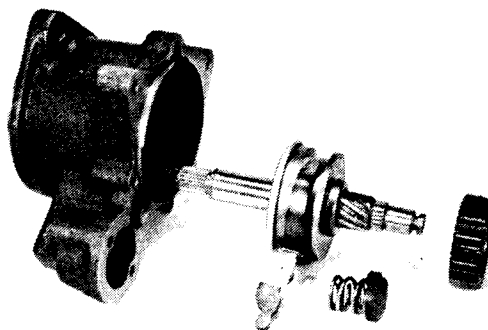

- (9) Replace the ball bearings. The ball bearings fitted to the ends of armature can be removed with a bearing puller. The front bracket bearing and sleeve bearing (fitted to the inner race of ball bearing) cannot be removed for replacement. These bearings are to be replaced as an assembly including the front bracket.

4. Alternator removal and installation

- (1) Disconnect wire (1) between the alternator and relay and ground harness, unscrew the adjusting plate bolts, and remove the fan belt.
- (2) Unscrew bolts (2) securing the alternator bracket, and remove alternator assembly (3) from the engine.

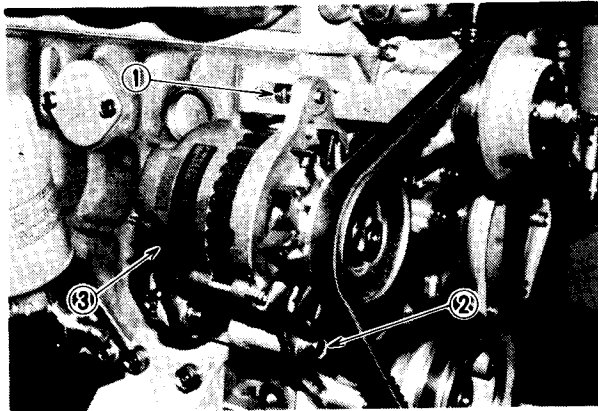

1-Bolt and washer
2-Bolt, nut and washer (2 pcs each)
3-Alternator assembly

5. Alternator disassembly and reassembly

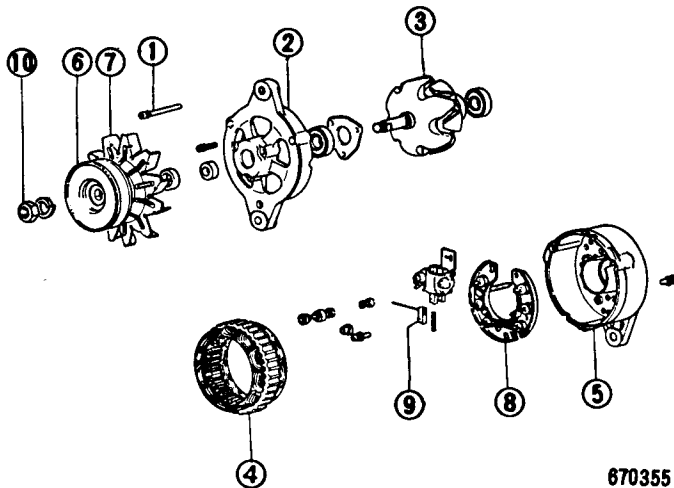

1-Bolt (3 pcs) 6-Pulley
2-Front bracket 7-Fan
3-Rotor 8-Diode
4-Stator coil 9-Brush
5-Rear bracket 10-Nut

670355

- (1) Pull the three through bolts, and break the alternator into the rotor (complete with front bracket and pulley) and stator (complete with rear bracket).

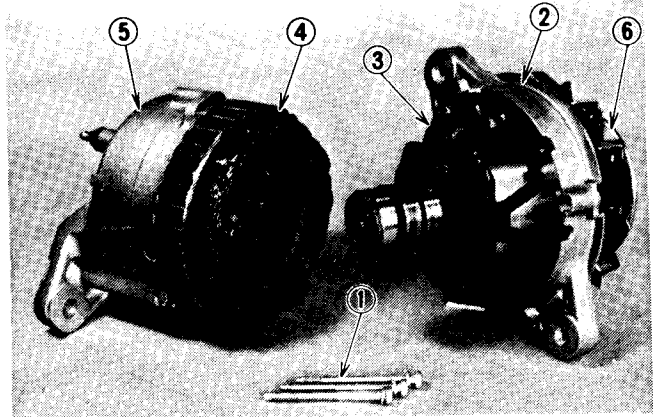

1-Bolt (3 pcs) 4-Stator coil
2-Front bracket 5-Rear bracket
3-Rotor 6-Pulley

- (2) Hold the rotor in a vise. Unscrew the pulley nut, and remove the pulley.

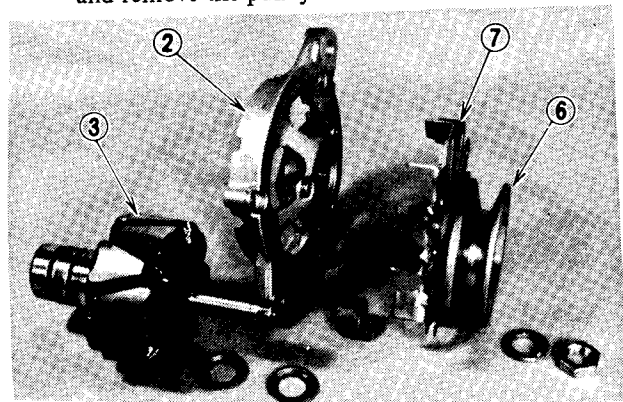

2-Front bracket 6-Pulley
3-Rotor 7-Fan

- (3) To reassemble, follow the reverse of disassembly procedure. Lift two brushes up into the brush box and pass a pin through the screw holes in the box and brushes to keep the brushes depressed. After reassembling the alternator, be sure to remove the pin.

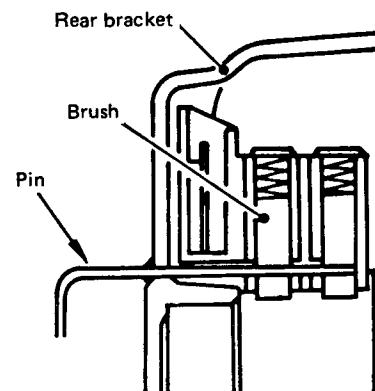

670220

6. Preheating system

Removal and installation of glow plugs

- (1) Before removing glow plugs from the engine, be sure to disconnect battery terminals.
- (2) Disconnect cable (1) from No. 4 cylinder glow plug. Loosen glow plug connection plate attaching nut (2) and remove connection plate (3).

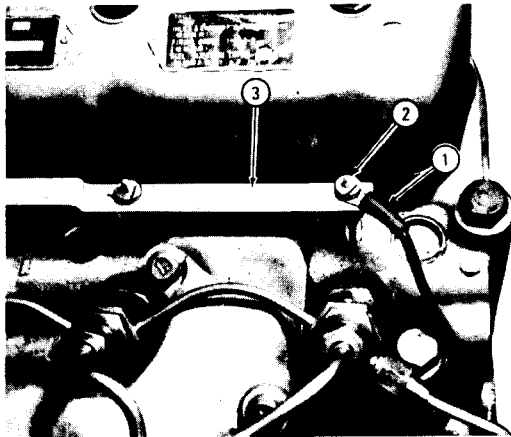

402591

- 1-Cable
2-Nut
3-Connection plate

- (3) Remove all glow plugs from the cylinder head. Take out packings from glow plug installation holes.
- (4) To install, follow the reverse of removal procedure.

7. Inspection and adjustment

7-1 Starter

- (1) Inspection before disassembly
 - (a) Checking the starting circuit for operation

With the starter in place, check to be sure that —

 - 1) The battery is in good condition, with its cell plates showing no evidence of “sulfation” or any other faulty condition, and is in fully charged state.
 - 2) The battery terminal connections are clean and tight.
 - 3) The starter terminal connections are tight.
 - 4) The wires are securely connected to terminals, and are free of any insulation stripping due to fraying, there being no signs of grounding or breaking.
 - 5) The starter switch closes and opens the circuit positively at each position.

Do not jump into a conclusion that the starter is in trouble when the engine refuses to fire up upon cranking: the engine could be in trouble.

(b) No-load test

If the starter is suspected of trouble, take it down from the engine and run a no-load test on it to find out if it is really in trouble.

When removing the starter, be sure to have the battery switch turned off.

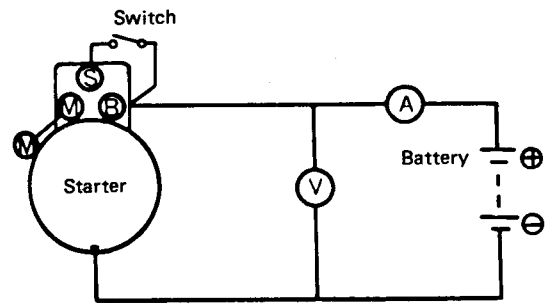

J8843

No-load test circuit

Here's how to carry out the no-load test: Form a test circuit with a voltmeter and an ammeter, as shown, using a fully charged 24-volt battery; close the switch to run the starter until its speed rises to and above 4000 rpm; and then read the voltmeter and ammeter when the starter is spinning. The ammeter should show that the starter is drawing not more than 130 amperes, with the voltmeter indicating at least 11 volts (at the speed of at least 4000 rpm); if not, estimate the cause of the trouble by consulting the troubleshooting guide, which follows:

Starter troubleshooting guide

Symptom	Possible cause
Large current and low speed	1) Bearings are dirty, or need lubrication. 2) Rotor (armature core) is rubbing the pole pieces. 3) Grounded coil in the armature or in the field. 4) Short-circuit in the armature coils.
Large current but no speed	1) Magnetic switch is grounded and is not working. 2) Grounded coil in the armature or in the field. 3) Seized bearing.
No current and no speed	1) Open-circuited coil in the armature or in the field. 2) Broken brush pigtail. 3) No conduction between brushes and commutator because of "high mica" condition or dirty commutator surface.
Small current and low speed and torque	Loose coil connection in the field.
Very large current, very high speed and low torque	Short-circuited field coil.

The best way of testing the starter is to run it under loaded condition, but that requires special testing equipment. For ordinary servicing purposes, the no-load test and troubleshooting guide will do.

(2) Inspection after disassembly

- (a) Using a ground tester or megger, check armature coil and commutator for short circuit. If there is any continuity between commutator and armature shaft, armature coil and commutator are short circuited.

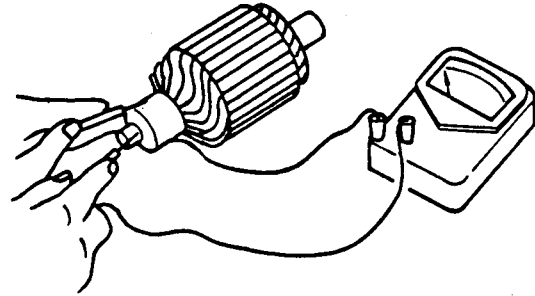

670202

- (b) A growler is generally used to test armature for short circuit in its winding. Place armature on a growler, and rotate it slowly while holding a steel strip over armature. If there is any short circuit between cores, the strip will vibrate and be attracted to armature. If so, replace armature.

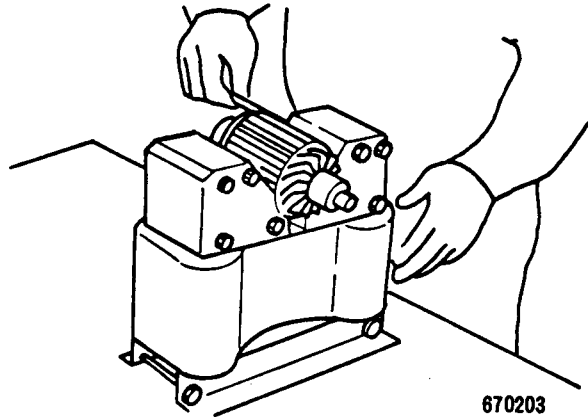

670203

- (c) Measure commutator runout with a dial gauge. Repair commutator if the runout exceeds the limit.

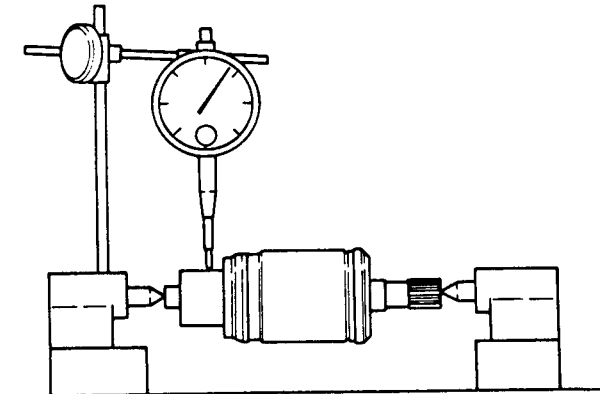

Specifications

Unit: mm (in.)

Item	Assembly standard	Repair limit	Grinding limit
Commutator runout	0.05 (0.0020)	0.3 (0.012)	31 (1.22)

(d) Brushes and brush springs

- 1) Measure brush length. Replace brush if the length exceeds the service limit.

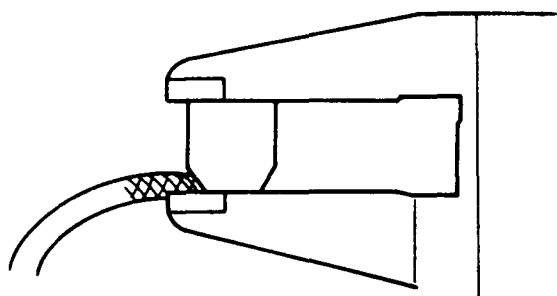

670208

Specifications		Unit: mm (in.)
Item	Assembly standard	Service limit
Brush length	18 (0.71)	11 (0.43)

- 2) Using a spring balance and new brush, check spring pressure. Replace spring if the pressure is below the service limit.

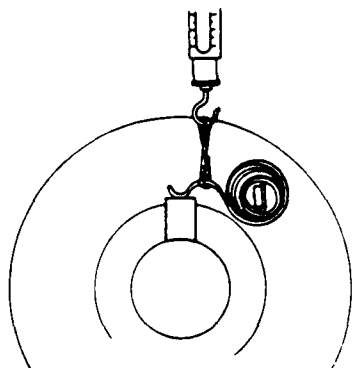

Specifications		Unit: kg (lb)
Item	Assembly standard	Service limit
Spring pressure	3.5 (7.7)	2 (4.4)

(e) Pinion gap adjustment

Connect starter and battery as shown to allow pinion to shift against stopper. Under this condition, push pinion back, and measure gap.

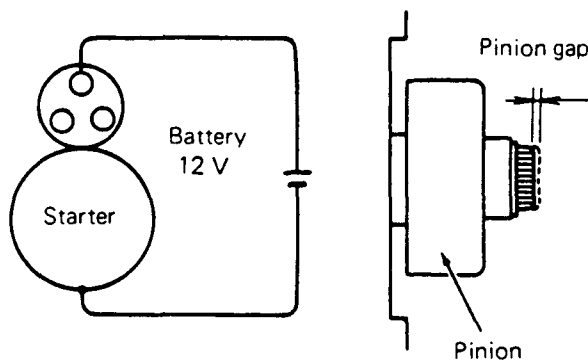

Specifications		Unit: mm (in.)
Item	Assembly standard	
Pinion gap	0.5 ~ 2.0 (0.020 ~ 0.079)	

NOTE

To adjust pinion gap, increase or decrease thickness of washers used between mating faces of magnetic switch and front bracket.

(f) No-load test

After adjusting pinion gap, connect starter and battery with an ammeter and voltmeter as shown, and test starter for performance.

NOTE

Use thick wires and tighten terminal securely.

If current and speed meet the following specifications when battery voltage is 11 volts, starter is satisfactory:

Specifications	
Current	Speed
130 (A), max.	4000 rpm, min.

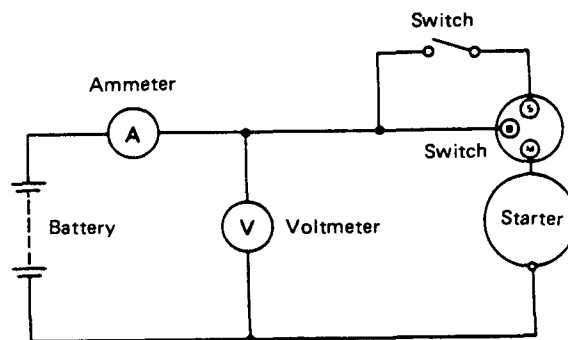

(3) Inspection of brushes and commutator

- (a) Check the brushes for wear. A brush worn down excessively should be replaced by a new one. When the brush is replaced, grind the brush against the commutator surface by using #250 sandpaper so that it makes a full-face contact with the commutator.
- (b) Check the mica insulation for condition. It should be "undercut," that is, the segment between two adjacent mica should be slightly proud of the mica surface, as viewed in the cross section. Since the commutator surface is subject to gradual wear, a point will be reached in the course of service, where the segments become flush with the mica. If the commutator in such a condition is kept in service, the mica will tend to interfere with the satisfactory commutation. Before this point is reached, it is necessary to recondition the commutator surface by regrinding or sanding with #400 sandpaper and to undercut the mica properly, as shown below:

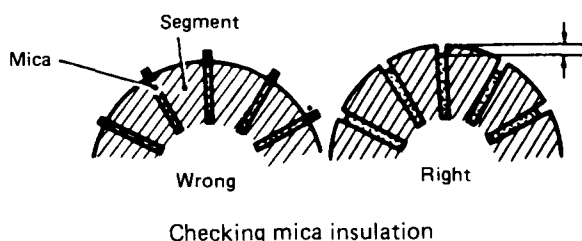

7-2 Alternator

(1) Alternator and regulator inspection before disassembly

- (a) If charging system is found defective, check for items below before making adjustment or repair:
- Fan belt tension
 - Loose connections, open short circuit in charging system wiring
 - Trouble of charging system due to defective battery

(b) Output test on a test bench

Remove the alternator from the engine. Connect it in a test circuit as shown at upper right, and operate it by a motor for testing.

Close the switches K_1 and K_2 under the state where very little load current flows in the test circuit by varying load resistance to the maximum. Gradually increase alternator speed

while keeping the terminal voltage at constant 13.5 volts, and read the ammeter at 2500 rpm. The alternator is satisfactory if the ammeter registers at least 30 amperes.

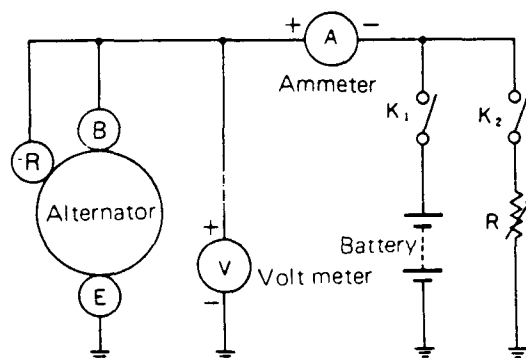

(c) Output test on a machine

Place a switch in the circuit between the battery and alternator. With the switch kept open, connect an ammeter (60-ampere class) and a voltmeter to the circuit.

Make sure that the voltmeter registers the battery voltage when the switch is closed.

Start the engine, and turn on the lamp switch. Increase the engine (alternator) speed, and read the ammeter when the alternator speed is 5000 rpm. The alternator is satisfactory if the ammeter registers at least 70% of the nominal output.

NOTE

This test is a first-aid test. It is recommended that the alternator be tested on a test bench for close inspection.

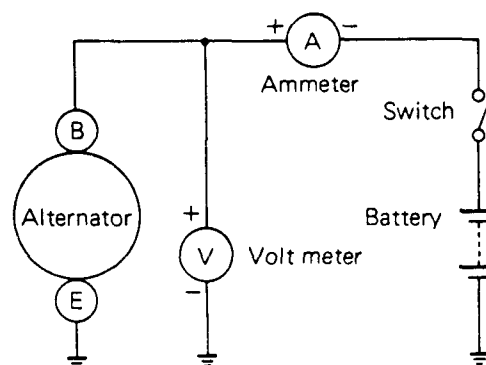

(2) Regulator voltage test

(a) Test on a test bench

Use a fully charged battery. Close the switch, and gradually increase the alternator speed, and gradually increase the alternator speed. Make sure that the current is below 5 amperes and the voltage is 14.1 to 14.7 volts when the alternator speed reaches 5000 rpm. If this requirement is not met, replace the regulator assembly. It is impossible to reset the regulator voltage.

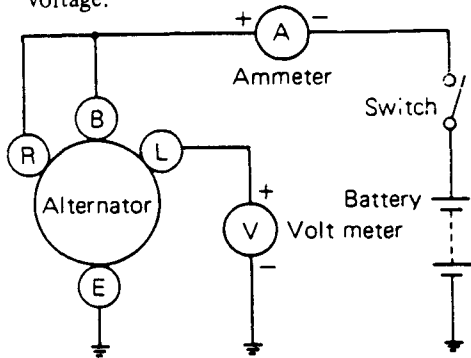

(b) Test on a machine

Connect a voltmeter in the circuit between the terminal L and ground. Turn on the battery switch to make sure that the voltage is 0 (zero). If the voltmeter needle deflects, the alternator is defective, or the circuit is misconnected. With the ammeter terminals short-circuited to prevent the starter current from flowing to the ammeter, start the engine.

If the charging current is below 5 amperes when the engine is running at about 2000rpm, read the voltmeter.

If it exceeds 5 amperes, charge the battery for a while, or replace the battery with a fully charged one. Another method is to connect a 1/4 ohm (25 W) resistor in series with the battery to limit the charging current.

The regulated voltage should be 14.1 to 14.7 volts; if not, replace the regulator assembly.

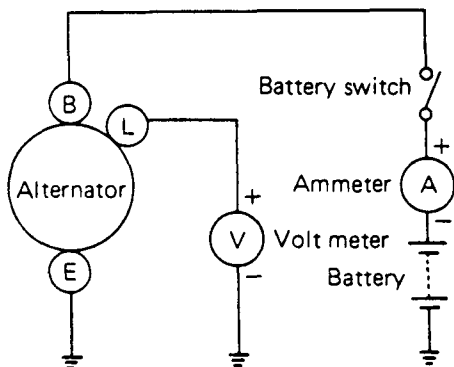

(3) Alternator inspection after disassembly

(a) Inspection of each diode

Check for continuity between the wire lead and the heat sink. Any continuity, if noted, means that the diode is shorted; no continuity means an open diode.

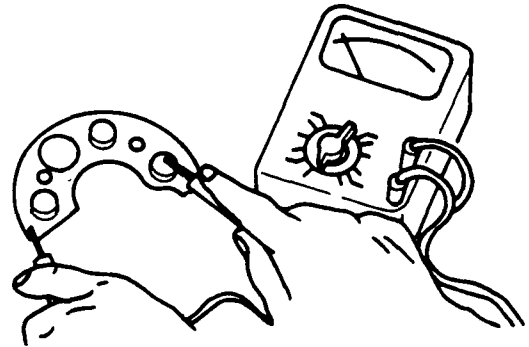

Checking diodes

(b) Field coil inspection

The field coil is in good condition if the resistance between the slip rings is approximately 14.3 ohms at a temperature of 20°C (68°F).

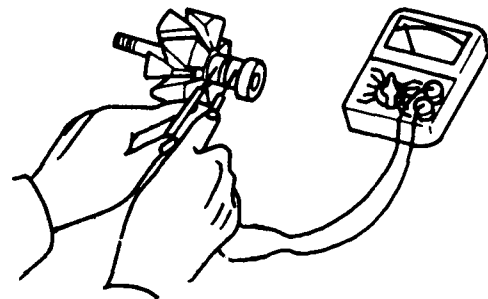

Checking field coil

(c) Armature inspection

Alternatively check four wire leads of the armature coil for continuity with a tester as shown:

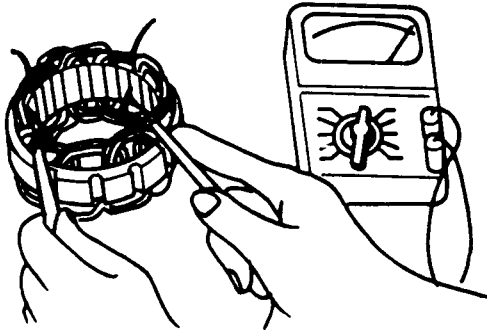

Checking armature

If there is no continuity between the wire leads, it is an indication that the armature has open circuit. Replace the armature with a new one. Then, check the armature for continuity between the wire lead and core. If there is continuity, it is an indication that there is a grounded circuit between the wire and core. In this case, too, the armature should be replaced.

(d) Brushes

Any brush which is worn beyond the service limit should be replaced with a new one.

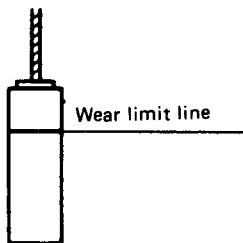

J20198

7-3 Battery

Check the electrolyte level in the battery cells, making sure that it is 10 mm (5/16 in.) above cell plates. Check the specific gravity of electrolyte. If it is below 1.260 at 20°C (68°F), prepare an electrolyte of 1.260 specific gravity and add it to the battery. A specific gravity below 1.190 means that the battery is half discharged; in such a case recharge the battery.

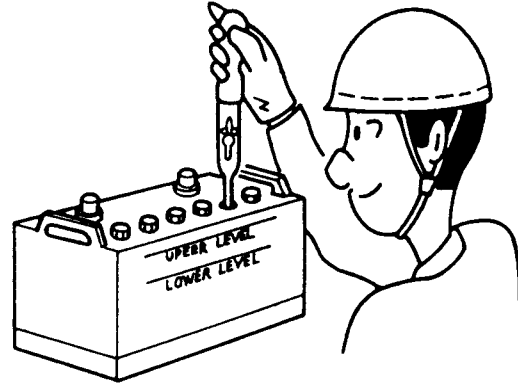

Checking electrolyte specific gravity

7-4 Glow plugs

Connect the positive (+) lead to the portion A of the plug with the portion B grounded to see if the plug glows red. The plug is in good condition if it glows red.

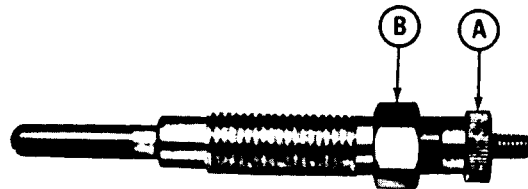

Checking glow plug

BENCH TEST

When the engine is overhauled, it is advisable to conduct the bench tests for checking the engine performance. The purpose of bench tests is to make sure that each major component has been properly serviced.

1. Visual inspection

Couple the engine to the dynamometer and inspect as follows:

- (1) Starting the engine
 - (a) Check the amounts of cooling water, lubricating oil and fuel oil. Bleed air out of the fuel system.
 - (b) Place the starter switch in PREHEAT position to preheat the combustion chambers. The glow plug indicator lamp will glow red within 20 seconds. If not, check the preheating system for condition.
 - (c) Place the starter switch in START position to start the engine. Do not move the governor control lever to INCREASE position.
 - (d) After starting the engine, manipulate the governor control lever to run the engine at idling speed.
- (2) After starting the engine

Check the following items and repair if necessary.

 - (a) Abnormal oil pressure and oil leakage.
 - (b) Abnormal noise.

If knocking is heard while water temperature is low and the noise dies away as water temperature rises, the engine is in good condition.
 - (c) Color of exhaust gases.
 - (d) Leakage of cooling water.
 - (e) Leakage of fuel oil.
 - (f) Fuel injection.
- (3) Running-in the engine

While running-in the engine, check the following items and repair if necessary.

 - (a) Oil pressure (3 ~ 4 kg/cm² or 42.7 ~ 56.9 psi).
 - (b) Temperature of cooling water (75 ~ 85°C or 167 ~ 185°F).
 - (c) Temperature of lubricating oil (60 ~ 70°C or 140 ~ 158°F in oil pan).
 - (d) Abnormal noise.
 - (e) Excessive blow-by, water leakage and oil leakage.

- (f) The relationship between the load and running-in period is as follows:

After running-in the engine, check the valve clearance.

Engine speed rpm	Load PS	Time min
1000	0	30
1500	7.5	30
2000	15	60
2500	20	60

2. Performance tests

- (1) Test condition

The engine must be equipped with the air cleaner and alternator.
- (2) Test items
 - No-load maximum speed test (governor set)
 - Fuel injection quantity test (control rack set)
 - No-load minimum speed test (idling speed set)
- (3) Test procedures (with dynamometer pointer in OFF position)
 - (a) No-load maximum speed test (governor set)

While the temperatures of cooling water and oil are still high after engine running-in, set the no-load maximum speed.
 - (b) Fuel injection quantity test (control rack set)

The fuel injection quantity can be set by means of the governor fuel set lever. Loosening the set screw at the top of the fuel set lever will increase the fuel injection quantity, and vice versa.
 - (c) Move the control lever toward LOW SPEED position and adjust the stop screw to set the idling rpm to 650 to 700.
 - (d) Tune-up of engine output

The diesel engine output is based on the atmospheric pressure and temperature. Therefore, the output must be tuned up under standard conditions. Multiply the output measured by the factor. This factor can be computed by the following equation.

$$K = \frac{760 - 11.4}{H - H_w} \sqrt{\frac{273 + t}{293}}$$

Where: H = atmospheric pressure
in mmHg
Hw = partial pressure of vapor in
atmosphere in mmHg
t = room temperature in °C (°F)

MAINTENANCE STANDARDS

Unit: mm. (in.)

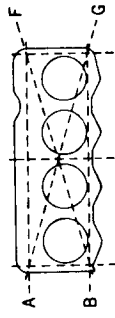
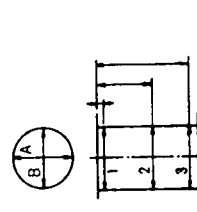
Group	Item	Nominal dimension	Assembly standard [Standard clearance]	Repair limit [Clearance]	Service limit [Clearance]	Remedy	Remarks				
General	Maximum rpm (no-load)		Varies according to customers' specifications.			Adjust governor.					
	Minimum rpm (no-load)		650 ~ 700								
	Compression pressure		26 kg/cm ² (370 psi), min (at 150 ~ 200 rpm)		20 kg/cm ² (284 psi)		Oil and water temperatures: 20 ~ 30°C (68 ~ 86°F)				
			3 ~ 4 kg/cm ² (43 ~ 57 psi) (at 1500 rpm)		2 kg/cm ² (28.4 psi)						
	Engine oil pressure		1 ~ 2 kg/cm ² (14.2 ~ 28.4 psi), min (at idle speed)		0.5 kg/cm ² (7.1 psi)		Oil temperature: 70°C (158°F)				
	Valve timing [3 mm (0.12 in.) added to valve side]	Intake valves	Open	±3°				These values are to be referred to in measuring timing and differ from actual timing.			
			Close								
		Exhaust valves	Open								
			Close								
Fuel injection timing											
			Engine specifications (rpm)	1500	1800	2000	2200	2500	3000	3600	
			BTDC (°)	23	24	25	26	28	30	33	
Crankcase and main moving parts	Warpage of gasketed surface		0.05 (0.0020), max	0.20 (0.008)		Regrind if warpage is minor.					
	Cylinder sleeve	Inside diameter	84 (3.307)	+0.035 (0.00138) 0	+0.20 (+0.008)	0.70 (0.0276)	Hone sleeve to 0.25 (0.0098), 0.50 (0.00197) or 0.75 (0.0295) oversize with prescribed tolerance.	All sleeves should be finished to the same oversize. Hone cylinder bore to 87 - 0.010 (3.425 - 0.00039) and heat the crankcase. Press sleeves into crankcase and machine each sleeve ID to assembly standard. 			
		Out of roundness Taper		0.01 (0.0004), max 0.015 (0.0006), max			Oversize pistons and piston rings should be used.				

Unit: mm (in.)

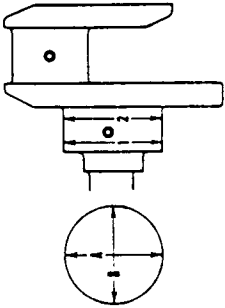
Group	Item	Nominal dimension	Assembly standard [Standard clearance]	Repair limit [Clearance]	Service limit [Clearance]	Remedy	Remarks		
Crankcase and main moving parts	Clearance on crankshaft journal (in two directions at right angles to each other with bearing in place)	65 (2.559)	0.035~0.100 [(0.00138~0.00394)]	0.20 [(0.0079)]	-0.9 (-0.035) (at crankshaft journal OD)	Replace bearing if repair limit is reached. Regrind crankshaft journals and use under-size bearings 0.25 (0.0098), 0.50 (0.0197) or 0.75 (0.0295) if service limit is reached.			
								Main bearings	
	Thrust clearance	3.7 (0.1457)	0.1 ~ 0.189 [(0.004 ~ 0.00744)]	0.30 [(0.0118)]		Replace thrust bearing.			
	Inside diameter	22 (0.87)	+0.033 (0 0		+0.10 (+0.0039)				
	Fit on tappets	Tappet holes		0.035 ~ 0.098 [(0.00138 ~ 0.00386)]	0.12 [(0.0047)]	+0.10 (0.0039) (at tappet hole dia.)	Replace tappet if repair limit is reached.		
									With bushings 0.040 ~ 0.090 [(0.00157 ~ 0.00354)]
									Without bushings 0.06 ~ 0.11 [(0.0024 ~ 0.0043)]
	Fit on camshaft journals	Camshaft bushing holes	No. 1	54 (2.126)	0.15 [(0.0059)]		Rebore holes and insert bushings if repair limit is reached.		
			No. 2						
			No. 3						53 (2.087)

Unit: mm (in.)

Cylinder head		Cylinder head		Cylinder head		Cylinder head		Cylinder head		Cylinder head		Cylinder head		Cylinder head		Cylinder head		Cylinder head		Cylinder head	
Cylinder head	Warpage of gasketed surface	1.35 (0.0531)	0.05 (0.0020), max	0.20 (0.0079)	Regrind if warpage is minor.																
	As-installed thickness of gasket	±0.05 (±0.0020)																			
Valves	Diameter of valve stem	Intake	-0.045 ~ -0.00177 (-0.004)	-0.10 (-0.004)	Replace valve guide if repair limit is reached.																
		Exhaust	-0.060 ~ -0.00236 (-0.008)	-0.15 (-0.0059)																	
	Clearance of valve stem in guide	Intake	0.055 ~ 0.085 (0.00217 ~ 0.00335)	0.15 (0.0059)	1.3 (0.051)																
		Exhaust	0.070 ~ 0.105 (0.00276 ~ 0.00413)	0.20 (0.0079)																	
Valve sinkage	0.8 (0.031)	±0.2 (±0.008)	1.3 (0.051)																		
Margin (valve head thickness)	1.7 (0.067)	±1.2 (0.047)	* Refacing limit																		
Face runout of stem	0.03 (0.0012), max (perpendicularity to valve face)																				
Valve guide length outside hole	18 (0.709)	±0.3 (±0.012)																			
Valve seat angle	30°																				
Valve seat width	1.4 (0.055)	±0.14 (±0.0055)	1.6 (0.063)																		
Free length	48.85 (1.9232)																				
As-installed length	43 (1.69)	44 (1.73)	Adjust by means of shim(s) if repair limit is reached.																		
Load compress spring to initial working length [43 mm (1.69 in.)] kg (lb)	19 ± 1 (41.9 ± 2.21)																				
Squareness	1.5°, max																				
																				Squareness of each end with respect to center line	

Unit: mm (in.)

Group	Item	Nominal dimension	Assembly standard [Standard clearance]	Repair limit [Clearance]	Service limit [Clearance]	Remedy	Remarks	
Cylinder head	Valve clearance	0.25 (0.0098) (cold setting)					0.25 (0.0098) clearance may also be obtained by warm setting if intake and exhaust valves are at the same temperature.	
	Rockets	Inside diameter	+0.061 (+0.00240) 0					
		Diameter of rocker shaft	18 (0.709)	-0.016 (-0.00063) -0.034 (-0.00134)				
		Fit on shaft	18 (0.709)	0.016 ~ 0.095 [(0.00063 ~ 0.00374)]	0.10 (0.0039)†		Replace bushings if repair limit is reached. Replace shaft if the limit is exceeded.	
	Push rods	Runout	0.4 (0.016), max				With both ball ends supported.	
	Exhaust manifold	Warpage on gasketed surface			0.2 (0.008)			
		Runout (measured with end journals held in "V" blocks)		0.02 (0.0008), max	0.05 (0.0020)		Straighten or replace crankshaft.	
	Main moving parts	Crankshaft	Diameter of journals	65 (2.559)	-0.015 (-0.00059) -0.035 (-0.00138)	-0.15 (-0.0059)		-0.9 (-0.035)
			Out of roundness of crankpins and journals		0.01 (0.0004), max	0.03 (0.0012)		
		Taper of crankpins and journals						
Diameter of crankpins		58 (2.283)	-0.035 (-0.00138) -0.055 (-0.00217)	-0.20 (-0.008)				
Filllet radius		3 (0.12)	± 0.2 (0.008)					
	Variance in angle among crankpins		± 20'					

Unit: mm (in.)

Crankshaft	Center-to-center dimension between journals and crankpins	47 (1.850)	± 0.05 (± 0.0020)				
	Parallelism between crankpins and journals		0.01 (0.0004), max as runout				
Pistons	Standard	83.90(3.3031)	± 0.015 (± 0.00059)	-0.2 (-0.008)			Measure in the direction transverse to piston pin.
	0.25 (0.0098) oversize	84.15(3.3130)					
	0.50 (0.0197) oversize	84.40(3.3228)					
	0.75 (0.0295) oversize	84.65 (3.3328)					
	Protrusion above crankcase						
Difference in weight among pistons per engine			± 5 g (± 0.18 oz)				

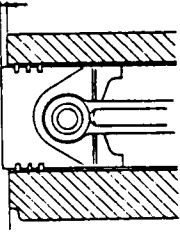

Unit: mm (in.)

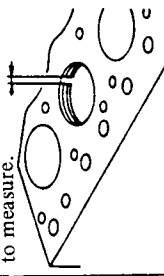
Group	Item	Nominal dimension	Assembly standard [Standard clearance]	Repair limit [Clearance]	Service limit [Clearance]	Remedy	Remarks
Main moving parts	Piston rings	Gap	0.30 ~ 0.50 {(0.0118 ~ 0.0197)}	1.5 {(0.059)}			 <p>Compress rings to 84 (3.31) dia. to measure.</p>
		Diameter	25 (0.984)	0 -0.006 (-0.00024)			
	Fit in piston pin bushings		0.020 ~ 0.051 {(0.00079 ~ 0.00201)}	0.08 {(0.0031)}	Replace piston pin or bushing. (Ream if necessary.)		
						Inside diameter of piston pin bushing	25 (0.984)
	Bend, twist		0.05/100 (0.002/4),max	0.15/100 (0.0059/4)			
						Crankpin diameter and fit in connecting rod bearing	58 (2.283)
	Connecting rods						

Unit: mm (in.)

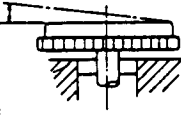
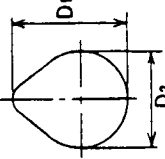
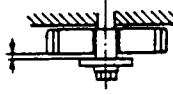
Main moving parts		Tuning gear train						
Connecting rods	End play			$0.15 \sim 0.35$ $(0.0059 \sim 0.0138)$	0.50 (0.0197)	Replace connecting rods.		
	Difference in weight among rods per engine			$\pm 2g (\pm 0.88 \text{ oz})$				
Flywheel	Flatness				0.5 (0.020)	Grind or replace.		
	Runout			$0.15 (0.0059), \text{ max}$		Replace flywheel.		
Camshaft	Cam height	Intake	$D1 \ 46.916^{+0.1}_{-0.3}$ $(1.84708 \sim 1.8882)$	$D1 - D2 = 6.684$ (0.26315)		Replace camshaft.		
		Exhaust	$D1 \ 45.944^{+0.1}_{-0.3}$ $(1.80882 \sim 1.84708)$	$D1 - D2 = 7.344$ (0.28913)				
	Diameter of journal	No. 1, 2	54 (2.126)					
		No. 3	53 (2.087)	-0.04 (-0.0016)				
	Runout			$0.02 (0.0008), \text{ max}$	0.05 (0.0020)	Straighten or replace.		
	End play		5 (0.197)	$0.05 \sim 0.112$ $(0.00197 \sim 0.00441)$	0.3 (0.012)	Replace thrust plate.		
Idle	Inside diameter of bushings	36 (1.417)	$+0.025$ (0)					
	Diameter of shaft		-0.025 (-0.00098)					
	Fit of shaft in bushing		$0.025 \sim 0.075$ $(0.00098 \sim 0.00295)$	0.1 (0.004)	Replace bushing.			
	End play	26 (1.02)	$0.05 \sim 0.15$ $(0.0020 \sim 0.0059)$	0.35 (0.0138)	Replace thrust plate.			

Unit: mm (in.)

Group	Item	Nominal dimension	Assembly standard [Standard clearance]	Repair limit [Clearance]	Service limit [Clearance]	Remedy	Remarks
Timing gear train	Idler	Thrust journal width in boss	26 (1.024) [0.05 ~ 0.15 (0.0020 ~ 0.0059)]	0.35 (0.0138)		Replace thrust plate.	
		Fit of shaft in holes in crankcase	30 (1.181) [0.09T ~ 0.045T (0.0035T ~ 0.0018T)]				
	Gear backlash		0.05 ~ 0.20 (0.0020 ~ 0.0079)	0.25 (0.0098)		Replace gear.	
Lubrication system	Oil pump	Running clearance between inner and outer rotors	0.013 ~ 0.015 (0.00051 ~ 0.00059)	0.25 (0.0098)			
		Sliding clearance between outer rotor and cover	0.04 ~ 0.09 (0.0016 ~ 0.0035)	0.15 (0.0059)		Reface case cover or case.	
		Clearance between outer rotor and body	0.20 ~ 0.275 (0.0079 ~ 0.01083)	0.50 (0.020)			
	Outside diameter of rotor shaft	13 (0.5118) [0 0 -0.15 (-0.0059)]					
	Fit of rotor shaft in body		0.032 ~ 0.074 (0.00126 ~ 0.00291)		0.15 (0.0059)	Replace pump case.	
Fuel system	Pressure that makes relief valve open	3.0 kg/cm ² (42.7 psi)	± 0.2 kg/cm ² (± 2.84 psi)				Oil pressure varies 0.15 kg/cm ² (2.13 psi) per 1 mm (0.04 in.) shim
		Outside diameter of tappets	20 (0.78)		0.1 (0.004)		
	Inside diameter of tappet holes						
	Outside diameter of roller	15 (0.591)	0 0 -0.027 (-0.00106)		-0.075 (-0.00295)		
	Fit of tappet roller pin in pin hole	7 (0.276)	0.013 ~ 0.071 (0.00051 ~ 0.00280)				
	Fit of tappet roller on roller pin	7 (0.276)	0.033 ~ 0.085 (0.00130 ~ 0.00335)				
	Delivery pressure	1.8 ~ 2.2 kg/cm ² (25.6 ~ 31.3 psi)					Injection pump rpm: 600

Unit: mm (in.)

Fuel system		Fuel feed pump			Fuel injection pump		
Delivery capacity		900 cc (55 cu in.)/min, min	600 cc (37 cu in.)/min, min				Check displacement with injection pump operated at 1000 rpm with a discharge pressure of 1.5 kg/cm ² (21 psi).
Air-tightness	Not greater than 50 cc (3.1 cu in.)/min (with bubbles not larger than 2 mm (0.08 in.) in size.)						Close pump discharge port with a plug. Apply an air pressure of 2 kg/cm ² (28 psi) to the pump, and keep the pump immersed in diesel fuel longer than 1 minute.
Pumping performance		40 seconds, max	50 seconds				Operate injection pump at 150 rpm to check the length of time required for the feed pump to start discharging.
Number of strokes for pumping (priming pump)		25, max	30				Operate priming pump handle at a speed of 60 strokes/minute. Check the number of strokes required for making the pump start discharging at a head of 1 meter (39-3/8 in.).
Plunger oil-tightness	150 ~ 200 kg/cm ² (2133 ~ 2844 psi), min		150 kg/cm ² (2133 psi), max				Pump rpm: 200
Delivery valve seating tightness							10 kg/cm ² (142 psi) pressure drop should not exceed 5 seconds.
Backlash between pinion and rack		[0.15 (0.0059)]					
Rack sliding resistance	150 g (5.3 oz), max with pump at stand-still; 50 g (1.8 oz), max with pump running at 1000 rpm						
Fit of tappets in pump housing	Outside diameter of tappet rollers	[0.02 ~ 0.062 / (0.00079 ~ 0.00244)]					
		15 (0.591)	0				
Plunger springs	Free length	49.4 (1.945)	+1 (+0.039) 0				
	As-installed length	44 (1.732)					
Free length of delivery valve spring		± 0.5 (± 0.020)					
Cam height (major diam)	32 (1.260)	0 ~ 0.1 (0 ~ 0.004)					
						Replace camshaft.	Check cam surface for condition.

Unit: mm (in.)

Group	Item	Nominal dimension	Assembly standard [Standard clearance]	Repair limit [Clearance]	Service limit [Clearance]	Remedy	Remarks																	
Fuel system	Fuel injection pump																							
		Inside diameter of tappet holes in pump housing	24 (0.945)			-0.15 (-0.0059)																		
		Axial play of camshaft bearing		0.03 ~ 0.05 [(0.0012 ~ 0.0020)]	0.1 [(0.004)]		Adjust by means of shim.																	
		Fit of tappet pin in tappet (hole)	7 (0.276)	0.013 ~ 0.050 [(0.00051 ~ 0.00197)]																				
		Fit of tappet floating bushing on tappet pin		0.033 ~ 0.078 [(0.00130 ~ 0.00307)]		Total play: 0.3 (0.012), [max]	Replace tappet complete.																	
		Fit of tappet roller on floating bushing	11 (0.433)	0.050 ~ 0.097 [(0.00197 ~ 0.00382)]																				
		Pre-stroke	1.95 (0.0768)	± 0.05 (± 0.0020)																				
		Intervals of beginning of injection	90°	± 30'																				
		Tappet clearance		0.2 ~ 0.3 [(0.008 ~ 0.012)]																				
		Injection quantity adjustment		Test conditions Nozzle tip: ND-DN40SDN32 Injection pipe: 6 x 1.6 x 600 mm (1/4 x 1/16 x 23-5/8 in) Injection pressure: 120 kg/cm ² (1706 psi) Delivery pressure: 2.0 kg/cm ² (28.44 psi) Test oil: ASTM Diesel fuel No. 2D				Mount injection pump on pump tester and allow pump to inject into the air.																
Governor		Injection quantity adjustment	<table border="1" style="width: 100%; border-collapse: collapse;"> <thead> <tr> <th>Pump speed rpm</th> <th>Rack position mm</th> <th>Injection quantity mm³ (cu in.)/rev./cyl.</th> <th>Variance mm³ (cu in.)/rev./cyl.</th> </tr> </thead> <tbody> <tr> <td>2000</td> <td rowspan="2">8.5 (0.335)</td> <td>36 ~ 39 (0.0022 ~ 0.0024)</td> <td rowspan="2">3 (0.00018), max</td> </tr> <tr> <td>1000</td> <td></td> </tr> <tr> <td>1000</td> <td>8.0 (0.315)</td> <td>32 ~ 35 (0.0020 ~ 0.0021)</td> <td rowspan="2">2 (0.00012), max</td> </tr> <tr> <td>200</td> <td>6.0 (0.236)</td> <td>10 ~ 16 (0.0006 ~ 0.0010)</td> </tr> </tbody> </table>	Pump speed rpm	Rack position mm	Injection quantity mm ³ (cu in.)/rev./cyl.	Variance mm ³ (cu in.)/rev./cyl.	2000	8.5 (0.335)	36 ~ 39 (0.0022 ~ 0.0024)	3 (0.00018), max	1000		1000	8.0 (0.315)	32 ~ 35 (0.0020 ~ 0.0021)	2 (0.00012), max	200	6.0 (0.236)	10 ~ 16 (0.0006 ~ 0.0010)				
	Pump speed rpm	Rack position mm	Injection quantity mm ³ (cu in.)/rev./cyl.	Variance mm ³ (cu in.)/rev./cyl.																				
	2000	8.5 (0.335)	36 ~ 39 (0.0022 ~ 0.0024)	3 (0.00018), max																				
1000																								
1000	8.0 (0.315)	32 ~ 35 (0.0020 ~ 0.0021)	2 (0.00012), max																					
200	6.0 (0.236)	10 ~ 16 (0.0006 ~ 0.0010)																						
	Fit of flyweight bushing on weight supporting shaft	7 (0.276)	0.019 ~ 0.047 [(0.00075 ~ 0.00185)]	0.025 [(0.00098)]			Replace flyweight assembly.																	
	Fit of flyweight bushing on governor shaft	11 (0.433)	0.016 ~ 0.052 [(0.00063 ~ 0.00205)]	0.10 [(0.0039)]			Replace bushing.																	
	Backlash of speed step-up gears		0.06 ~ 0.12 [(0.0024 ~ 0.0047)]	0.20 [(0.0079)]																				

Unit: mm (in.)

Fuel system		Governor							
Slip torque of gear complete									Adjust by means of shim.
Fit of governor sleeve on governor shaft				$0.4 \sim 0.6 \text{ kg-m}$ ($2.9 \sim 4.3 \text{ lb-ft}$)					
Fit of governor sleeve groove on sliding piece				$0.006 \sim 0.059$ ($0.00024 \sim 0.00232$)		0.15 (0.0059)			
Fit of floating lever on bolt				$0.03 \sim 0.13$ ($0.0012 \sim 0.0051$)		0.18 (0.0071)			Replace sliding piece.
Fit of floating lever on pin			6 (0.236)	$0.01 \sim 0.052$ ($0.00039 \sim 0.00205$)		0.08 (0.0031)			Replace floating lever or bolt.
Fit of shackle on pin				$0.01 \sim 0.055$ ($0.00039 \sim 0.00217$)					Replace floating lever or pin.
Fit of shackle on bushing				$0.025 \sim 0.07$ ($0.00098 \sim 0.00276$)					Replace shackle or bushing.
Fit of control lever shaft in bearing bushing			8 (0.315)	$0.02 \sim 0.13$ ($0.0008 \sim 0.0051$)		0.2 (0.008)			Replace shaft or bushing.
Fit of adaptor capsule on adaptor			5 (0.197)			0.18 (0.0071)			Adaptor should slide smoothly in axial direction.

Mechanical governor

Adjusting sequence	Item	Adjusting lever angle	Pump rpm	Control rack position RW, mm (in.)
1	High-speed control	$4^\circ \pm 5^\circ$	1150 1400 1300	$8.3 \sim 8.7$ (0.327 ~ 0.343) $3.3 \sim 3.9$ (0.130 ~ 0.154) $5.9 \sim 6.9$ (0.232 ~ 0.272)
2	Ungleich control	$4^\circ \pm 5^\circ$	350 600 700	$9.7 \sim 9.6$ (0.382 ~ 0.378) $8.7 \sim 9.3$ (0.343 ~ 0.366) $8.4 \sim 9.0$ (0.331 ~ 0.354)
3	Low-speed control	$-16^\circ \pm 5^\circ$	300 400 100	$5.5 \sim 6.1$ (0.217 ~ 0.240) $4.1 \sim 5.5$ (0.161 ~ 0.217) 14.8 (0.583), max
4	Adaptation to engine	Adjusting lever angle $4^\circ \pm 5^\circ$	Pump rpm 600	Injection quantity mm^3 (cu in.)/rev./cyl. 36.5 ± 1.5 (0.00223 \pm 0.00009) (by full-load stopper)
			1150	36 ± 1.5 (0.00220 \pm 0.00009) (by torque spring)
5	Stop lever operation		1400	6 ± 1 (0.00037 \pm 0.00006) (by lever)

RW shall be not more than 2 mm (0.08 in.) when stop lever is operated with adjusting lever VH placed in low-speed control position.

Unit: mm (in.)

Fuel system		Fuel injection nozzle		Injection pressure		120 kg/cm ² (1706.4 psi)		+10 kg/cm ² (+142.2 psi) 0		110 kg/cm ² (1564.2 psi)		Adjust by means of shim(s).		Injection pressure varies 10 kg/cm ² (142.2 psi) per 0.1 mm (0.004) of shim thickness.			
Fuel system		Fuel injection nozzle		Spray angle		0°						Test by means of hand tester, using diesel fuel at, 20°C or 68°F approx. If spray pattern is improper even after nozzle is washed in clean kerosene, replace nozzle tip.		Spray of fuel oil should be uniform and consists of fine droplets. No dribbling should be observed after each injection. "Throttle injection" should occur when the tester lever is operated slowly.			
				Needle valve seat oil-tightness		Seat shall show no sign of leakage under a pressure of 100 kg/cm ² (1422 psi).								Wash needle valve seat or replace nozzle tip.		Replace nozzle tip when needle surface is scratched or scored.	
Cooling system		Water pump bearings		Clearance of outer race in pump casing		47 (1.850) 40 (1.575)		[-0.018T ~ -0.014T] [(0.00071T ~ 0.00055T)]				Replace pump case or pump assembly.					
				Clearance of inner race on pump shaft		20 (0.787) 17 (0.669)		[-0.001T ~ 0.025T] [(0.00004T ~ 0.00098T)]		[-0.002T ~ 0.020T] [(0.00008T ~ 0.00079T)]				Replace bearing.		Replace bearing if it does not rotate smoothly.	
		Water pump impeller, vane-casing clearance (front and rear sides)		Radial play		20 (0.787) 17 (0.669)		[0.010 ~ 0.025] [(0.00039 ~ 0.00098)]		[0.010 ~ 0.022] [(0.00039 ~ 0.00087)]		[0.045] [(0.00177)]					
				Unit seals		0.5 ~ 1 (0.020 ~ 0.039)						0				Replace impeller and bearing if vanes are binding.	
		Thermostat		Carbon protrusion		1.5 (0.059) 18.1 (0.713)											
				Height (free length)		76.5°C (169.7°F) 9 (0.35)		± 2°C (± 3.6°F)									
Belt, tension		Temperature that makes valve start opening		90°C (194°F)		± 2°C (± 3.6°F)											
		Temperature that makes valve open fully		Deflection: 12 (about 1/2)													

Unit: mm (in.)

Group	Item	Nominal dimension	Assembly standard [Standard clearance]	Repair limit [Clearance]	Service limit [Clearance]	Remedy	Remarks																							
Electrical system	Commutator runout	0.05 (0.0020)	0.03 (0.0012)	0.1 (0.004)																										
		Height	18 (0.71)		11 (0.43)																									
		Spring pressure	3.5 kg (7.7 lb)		2 kg (4.4 lbf)																									
	Pinion-to-stopper clearance		0.5 ~ 2.0 [(0.020 ~ 0.079)]																											
	Starter	<table border="1"> <thead> <tr> <th colspan="2">No-load characteristic</th> <th colspan="2">Locked-rotor characteristic</th> <th colspan="2">Magnetic switch operating voltage</th> </tr> <tr> <th>Voltage (V)</th> <th>Current (A)</th> <th>Rpm</th> <th>Voltage (V)</th> <th>Current (A)</th> <th>Torque</th> <th>Switch IN</th> <th>Switch OFF</th> </tr> </thead> <tbody> <tr> <td>12</td> <td>130, max</td> <td>4000, min</td> <td>3</td> <td>1000, max</td> <td>2.8 kg-m (20.3 lb-ft), min</td> <td>8V, max</td> <td>When circuit is opened.</td> </tr> </tbody> </table>							No-load characteristic		Locked-rotor characteristic		Magnetic switch operating voltage		Voltage (V)	Current (A)	Rpm	Voltage (V)	Current (A)	Torque	Switch IN	Switch OFF	12	130, max	4000, min	3	1000, max	2.8 kg-m (20.3 lb-ft), min	8V, max	When circuit is opened.
		No-load characteristic		Locked-rotor characteristic		Magnetic switch operating voltage																								
		Voltage (V)	Current (A)	Rpm	Voltage (V)	Current (A)	Torque	Switch IN	Switch OFF																					
		12	130, max	4000, min	3	1000, max	2.8 kg-m (20.3 lb-ft), min	8V, max	When circuit is opened.																					
		Alternator	<table border="1"> <thead> <tr> <th colspan="2">No load (battery connected)</th> <th colspan="2">Under load (battery resistance load 30A connected)</th> </tr> <tr> <th>Voltage (V)</th> <th>Current (A)</th> <th>Voltage (V)</th> <th>Current (A)</th> </tr> </thead> <tbody> <tr> <td>13.5</td> <td>0</td> <td>1050, max</td> <td>13.5</td> <td>30</td> </tr> </tbody> </table>							No load (battery connected)		Under load (battery resistance load 30A connected)		Voltage (V)	Current (A)	Voltage (V)	Current (A)	13.5	0	1050, max	13.5	30								
			No load (battery connected)		Under load (battery resistance load 30A connected)																									
Voltage (V)			Current (A)	Voltage (V)	Current (A)																									
13.5		0	1050, max	13.5	30																									
Ball bearing		Rear side	Field resistance Ω at 20°C (68°F)					IC regulator	Adjusting voltage (V)																					
		Front side	3.4																											
	#6201																													
	#6302																													

SEALANT APPLICATION DATA

Where to apply	Mating face or parts	Sealant	Remarks
Oil pan gasket	Crankcase	ThreeBond 1102	Apply to bottom face for oil pan.
	Front/rear attaching faces	Atmojet	Apply to both sides of cork packing.
		ThreeBond 1207C	Apply to periphery of rubber packing.
Main oil gallery plug	Crankcase	Hermeseal H-1	Apply to hole in crankcase and also to plug after installing.
Crankcase screw plug	Crankcase	Hermeseal H-1	Apply to threaded portion.
Front plate gasket	Front plate	ThreeBond 1102	Apply when reassembling temporarily.
	Crankcase		Apply to the whole surfaces at reassembling.
Timing gear case gasket	Gear case	ThreeBond 1102	Apply when reassembling temporarily.
	Front plate		Apply to the whole surfaces at reassembling.
Water pump gasket	Plate	ThreeBond 1102	Apply when reassembling temporarily.
	Water pump		Apply to the whole surfaces at reassembling.
Pump plate gasket	Plate	ThreeBond 1102	Apply when reassembling temporarily.
	Crankcase		Apply to the periphery of port.
Oil filler attaching bolts	Oil filler/crankcase	ThreeBond 1102	Apply to threaded portion in assembly.
Water bypass hose fitting	Thermostat cover/water pump	Hermeseal H-1	Apply to threaded portion.
Gear case mounting bolts	Crankcase/gear case	Hermeseal H-1	Apply to threaded portion of one upper bolt and two lower bolts.

TIGHTENING TORQUE

Important bolts and nuts

Unit: kg-m (lb-ft)



Item	Torque
Cylinder head bolts	12.0 ± 0.5 (86.8 ± 3.6)
Main bearing cap bolts	8.5 ± 0.5 (61.5 ± 3.6)
Connecting rod cap bolts	5.5 ± 0.5 (39.8 ± 3.6)
Rocker shaft bracket bolts	1.5 ± 0.5 (10.8 ± 3.6)
Front plate bolts	1.0 ± 0.5 ((7.2 ± 3.6)
Timing gear case bolts	1.0 ± 0.5 (7.2 ± 3.6)
Camshaft thrust plate bolts	1.8 ± 0.5 (13.0 ± 3.6)
Idler thrust plate bolt	3.5 ± 0.5 (25.3 ± 3.6)
Crankshaft pulley nut	40.0 ± 0.5 (289.3 ± 3.6)
Rear plate bolts	3.5 ± 0.5 (25.3 ± 3.6)
Rear oil seal bolts	0.4 (2.9)
Flywheel bolts	8.5 ± 0.5 (61.5 ± 3.6)
Oil pan bolts	0.7 (5.1)
Oil pan drain plug	10.0 ± 0.5 (72.3 ± 3.6)
Nozzle holder retaining nuts	5.0 ± 0.5 (36.2 ± 3.6)
Injection pump delivery valve holders	3.0 ± 0.5 (21.7 ± 3.6)
Governor round nut	2.5 ± 0.5 (18.1 ± 3.6)

General bolts and nuts

(1) The values listed in this chart are for standard bolts. For other bolts, nuts and screws, refer to the related sections in this manual.

(2) The values listed below have a tolerance of $\pm 10\%$. When an impact wrench is used, a torque up to and including 14 kg-m (101 lb-ft) has a tolerance of $\pm 20\%$ and a torque above 14 kg-m (101 lb-ft) has a tolerance of $\pm 15\%$.

Unit: kg-m (lb-ft)

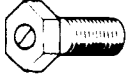
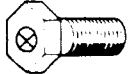
Automotive screw thread					Metric coarse screw thread				
Indication of bolt material					Indication of bolt material				
	"7" stands for "7T."		"8" stands for "8T."			"⊘" stands for "7T."		"⊗" stands for "8T."	
	w/spring washer		w/o spring washer			w/spring washer		w/o spring washer	
Bolt material	7T	8T	7T	8T	Bolt material	7T	8T	7T	8T
M6 × 1	0.6 (4.3)	0.9 (6.5)	0.7 (5.1)	1.0 (7.2)					
M8 × 1.25	1.4 (10.1)	1.9 (13.7)	1.7 (12.3)	2.2 (15.9)					
M10 × 1.25	2.9 (21.0)	3.8 (27.5)	3.4 (24.6)	4.5 (32.5)	M10 × 1.5	2.8 (20.3)	3.7 (26.8)	3.3 (23.9)	4.3 (31.1)
M12 × 1.25	5.2 (37.6)	6.8 (49.2)	6.1 (44.1)	8.0 (57.9)	M12 × 1.75	4.9 (35.4)	6.5 (47.0)	5.8 (42.0)	7.6 (55.0)
M14 × 1.5	8.4 (60.8)	11.1 (80.3)	9.9 (71.6)	13.1 (94.8)	M14 × 2	8.1 (58.6)	10.5 (75.9)	9.5 (68.7)	12.4 (89.7)
M16 × 1.5	12.6 (91.1)	16.6 (120.1)	14.8 (107.0)	19.5 (141.0)	M16 × 2	12.1 (87.5)	15.9 (115.0)	14.2 (102.7)	18.7 (135.3)
M18 × 1.5	18.2 (131.6)	23.9 (172.9)	21.4 (154.8)	28.1 (203.2)	M18 × 2.5	16.8 (121.5)	22.2 (160.6)	19.8 (143.2)	26.1 (188.8)
M20 × 1.5	25.2 (182.3)	33.2 (240.1)	29.7 (214.8)	39.0 (282.1)	M20 × 2.5	23.5 (170.0)	30.9 (223.5)	27.7 (200.4)	36.4 (263.3)
M22 × 1.5	33.4 (241.6)	43.9 (317.5)	39.3 (284.3)	51.7 (373.9)	M22 × 2.5	31.5 (227.8)	41.3 (298.7)	37.0 (267.6)	48.6 (351.5)
M24 × 1.5	42.2 (305.2)	55.5 (401.4)	49.7 (359.5)	65.3 (472.3)	M24 × 3	40.5 (292.9)	53.4 (386.2)	47.7 (345.0)	62.8 (454.2)

SPECIAL SERVICE TOOLS

Unit: mm

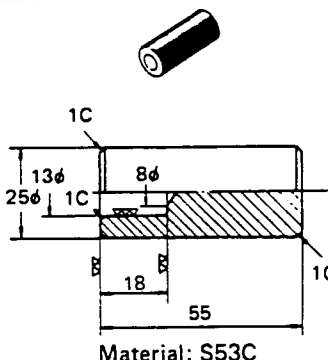
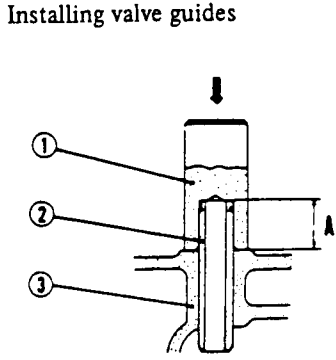
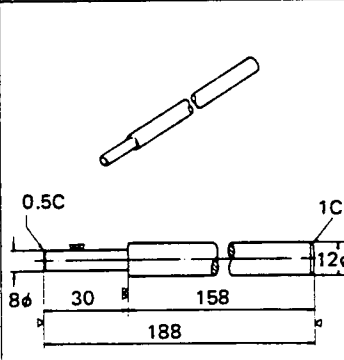
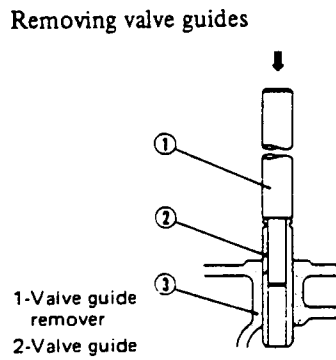
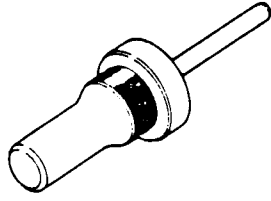
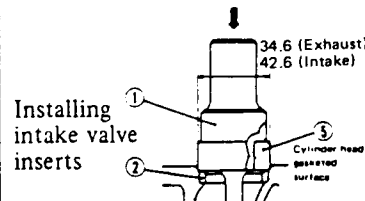
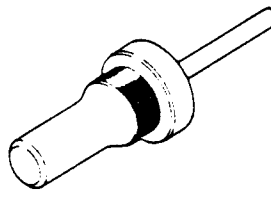
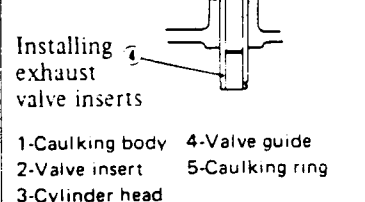
Tool No.	Tool name	Drawing or sketch	Qt.	Used for:
	Valve guide installer	 <p style="text-align: center;">Material: S53C</p>	1	<p>Installing valve guides</p>  <p>1-Valve guide installer 2-Valve guide 3-Cylinder head A-Guide length outside hole</p>
	Valve guide remover	 <p style="text-align: center;">Material: S53C</p>	1	<p>Removing valve guides</p>  <p>1-Valve guide remover 2-Valve guide 3-Cylinder head</p>
	Intake valve insert caulking tool		1	<p>Installing intake valve inserts</p>  <p>34.6 (Exhaust) 42.6 (Intake) Cylinder head beveled surface</p>
	Exhaust valve insert caulking tool		1	<p>Installing exhaust valve inserts</p>  <p>34.6 (Exhaust) 42.6 (Intake) Cylinder head beveled surface</p> <p>1-Caulking body 2-Valve insert 3-Cylinder head 4-Valve guide 5-Caulking ring</p>

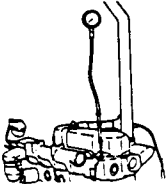
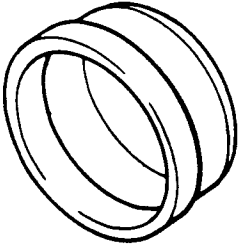
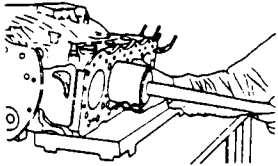
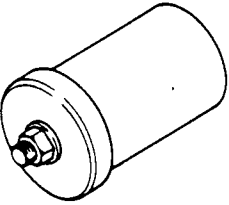
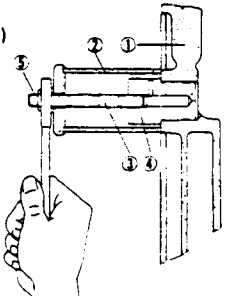
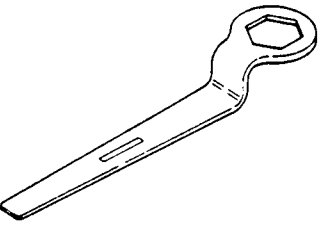
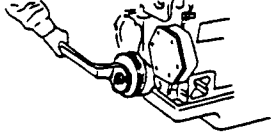
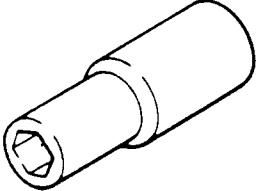
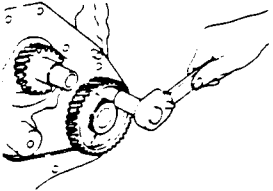
Tool No.	Tool name	Drawing or sketch	Qt.	Used for:
	Adaptor		1	Connecting pressure gauge to engine for compression measurement 
	Piston guide		1	Placing pistons in crankcase 
	Idler shaft puller		1	Removing idler shaft 1-Crankcase 2-Puller 3-Stud (M10) 4-Idler shaft 5-Nut 
	Cranking handle		1	Rotating crank pulley for engine cranking 
	Socket		1	Installing camshaft thrust plate 

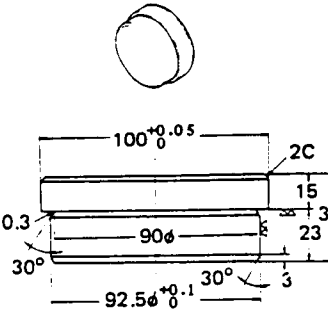
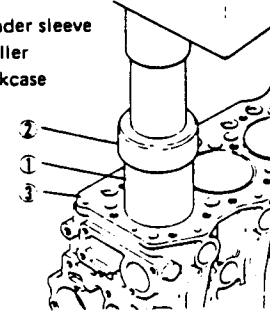
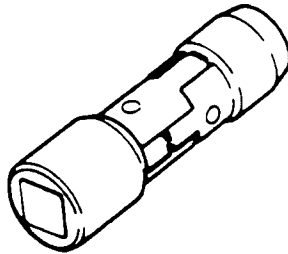
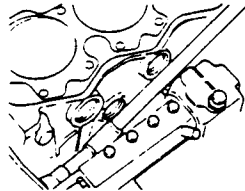
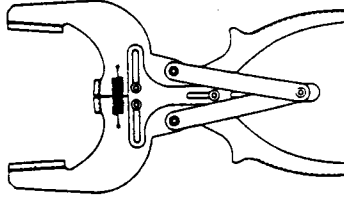
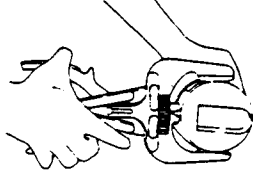
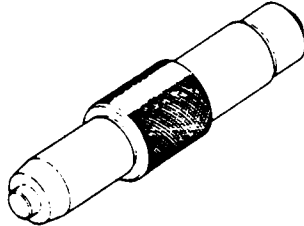
Tool No.	Tool name	Drawing or sketch	Qt.	Used for:
	Cylinder sleeve installer	 <p>Material: S43C</p>	1	<p>Installing cylinder sleeves</p> <p>1-Cylinder sleeve 2-Installer 3-Crankcase</p> 
	Universal extension		1	<p>Tightening fuel injection pump mounting bolts</p> 
	Piston ring tool		1	<p>Removing/installing piston rings</p> 
	Idler bushing puller		1	<p>Removing/installing idler bushing</p>

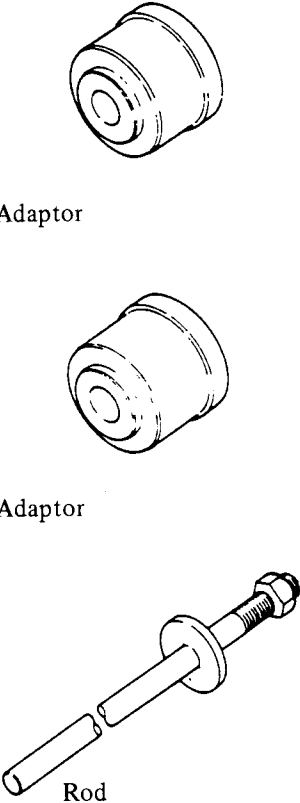
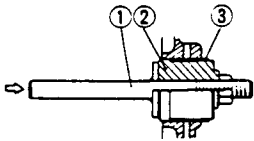
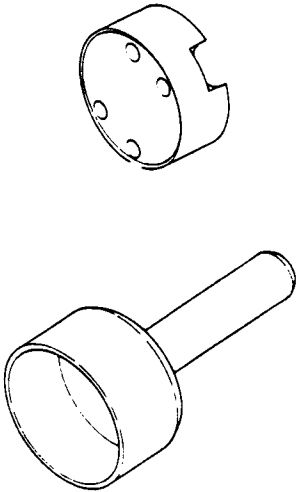
Tool No.	Tool name	Drawing sketch	Qt.	Used for:
	Camshaft bushing installer set	 <p>Adaptor</p> <p>Adaptor</p> <p>Rod</p>	1	<p>Removing/installing camshaft bushings</p>  <p>1-Rod 3-Camshaft bushing 2-Adaptor</p> <p>To be used together with guide piece (30891-04700) as a set</p>
	Sleeve installer set		1	<p>Installing crankshaft rear oil seal sleeve</p>



TROUBLESHOOTING

Complaint Possible cause		Engine will not start						Glow plugs do not glow red	Glow plugs glow red too early	Engine lacks power			Abnormal exhaust smoke		Engine knocks excessively	Engine is noisy	Engine runs rough	Engine hunts					
		Engine turns over but does not start			Starting motor does not turn over sufficiently to crank engine	Engine does not turn				A little exhaust smoke	Too much whitish exhaust smoke	Too much black exhaust smoke	When idling	When operating				Engine knocks excessively	Engine is noisy	Engine runs rough	When idling	When operating	
		No exhaust smoke	A little exhaust smoke	Too much exhaust smoke		Engine can be cranked manually	Engine cannot be cranked manually							Whitish exhaust smoke									Black exhaust smoke
Fuel system	Insufficient fuel supply to injection pump	○	○	—	—	—	—	—	○	—	—	—	—	—	—	—	—	—					
	Greater variance of injection quantity	—	—	○	—	—	—	—	—	—	—	○	—	—	—	—	—	—					
	Defective injection pump seals	—	—	—	—	—	—	—	—	—	—	—	—	—	—	—	—	—					
	Insufficient injection quantity	○	○	—	—	—	—	—	○	—	—	—	—	—	—	—	—	—					
	Excessive injection quantity	—	—	—	—	—	—	—	—	—	—	—	○	—	—	—	—	—					
	Improper fuel spray from injection nozzles	—	—	○	—	—	—	—	—	—	○	—	—	—	—	—	—	—					
	Excessive fuel return from injection nozzles	—	○	—	—	—	—	—	○	—	—	—	—	—	—	—	—	—					
	Injection timing too advanced	—	—	○	—	—	—	—	—	○	—	—	—	—	—	—	—	—					
	Injection timing too retarded	—	—	○	—	—	—	—	—	○	—	—	—	—	—	—	—	—					
	Defective governor control spring	—	—	—	—	—	—	—	—	—	—	—	—	—	—	—	—	—					
	Maladjusted governor damper spring	—	—	—	—	—	—	—	—	—	—	—	—	—	—	○	—	—					
	Engine speed too low	—	—	—	—	—	—	—	—	—	—	—	—	—	—	○	—	—					
	Failure of engine to stop properly	—	—	—	—	—	—	—	—	—	—	—	—	—	—	—	—	—					
	Poor grade of fuel oil	—	—	○	—	—	—	—	—	—	—	—	—	—	—	—	—	—					
Fuel viscosity too high	○	○	—	—	—	—	—	—	—	—	—	—	—	—	—	—	—						
Lubrication system	Poor grade of oil	—	—	—	—	—	—	—	—	—	—	—	—	—	—	—	—	—					
	Oil viscosity too high	—	—	—	—	—	○	—	—	—	—	—	—	—	—	—	—	—					
	Oil viscosity too low	—	—	—	—	—	—	—	—	—	—	○	—	—	—	—	—	—					
	Low oil pressure	—	—	—	—	—	—	—	—	—	—	—	—	—	—	—	—	—					
	Excessive oil leakage	—	—	—	—	—	—	—	—	—	—	—	—	—	—	—	—	—					
	Pumping up of oil	—	—	—	—	—	—	—	—	—	—	○	—	—	—	—	—	—					
	Clogged oil filter	—	—	—	—	—	—	—	—	—	—	—	—	—	—	—	—	—					
	Defective oil indicator switch or lamp	—	—	—	—	—	—	—	—	—	—	—	—	—	—	—	—	—					
Air system	Insufficient air	—	—	○	—	—	—	—	—	—	—	—	—	—	—	—	—	—					
	Poor compression	—	—	○	—	—	—	—	—	—	—	—	—	—	—	—	—	—					
	Low pressure at high atmospheric temperature (or altitude)	—	—	—	—	—	—	—	—	○	—	—	—	—	—	—	—	—					

(● For detailed information refer to the separate chart.)

	Engine vibrates excessively	Engine stalls	Poor response for deceleration	Engine does not pick up speed	Engine operates at high speeds but fails to stop	Engine turns in reverse direction	Excessive fuel consumption	Excessive oil consumption	Oil is diluted by fuel	Water in oil	Excessive blow-by	Defective lubrication system			Abnormal water temperature rise		Defective alternator		Remedy	
												When engine stops, warning lamp does not come on	Warning lamp comes on at low-speed operation	Warning lamp comes on at high-speed operation	Water temperature too high (Engine overheats)	Water temperature too low	Indicator lamp does not come on when engine stops	Indicator lamp comes on at high-speed operation		
																				●
																				●
																				Check and replace if necessary.
																				●
																				●
																				●
																				Replace nozzle tips.
																				●
																				●
																				Check and replace spring if necessary. Then adjust governor setting on bench.
																				Adjust.
																				Adjust idling set bolt. Hold lever in STOP position.
																				●
																				Use fuel for cold weather.
																				Use good quality oil.
																				Use proper viscosity oil.
																				Use proper viscosity oil.
																				●
																				Retighten and replace packing if necessary.
																				●
																				Change element and oil.
																				Check and replace if necessary.
																				●
																				●
																				(Adjust full-load setting of governor.)

Complaint Possible cause		Engine will not start						Engine lacks power		Abnormal exhaust smoke			Engine hunts						
		Engine turns over but does not start			Starting motor does not turn over sufficiently to crank engine.	Engine does not turn		Glow plugs do not glow red	Glow plugs glow red too early	A little exhaust smoke	Too much whitish exhaust smoke	Too much black exhaust smoke	When operating		Engine knocks excessively	Engine is noisy	Engine runs rough	When idling	When operating
		No exhaust smoke	A little exhaust smoke	Too much exhaust smoke		Engine can be cranked manually	Engine cannot be cranked manually						When idling	Whitish exhaust smoke					
					Engine knocks excessively			Engine is noisy											
Cooling system	Engine is too cold.	-	-	o	o	-	-	-	-	-	-	o	-	-	-	-	-	-	
	Radiator dissipates heat excessively	-	-	-	-	-	-	-	-	-	o	-	o	-	-	-	-	-	
	Insufficient coolant	-	-	-	-	-	-	-	-	-	o	o	-	-	-	-	-	-	
	Failure of radiator to dissipate heat properly	-	-	-	-	-	-	-	-	-	o	o	-	-	-	-	-	-	
	Water leak through cylinder head gasket	-	-	-	-	-	-	-	-	o	-	o	-	-	-	o	-	-	
	Cracks in crankcase water jacket	-	-	-	-	-	-	-	-	-	-	-	-	-	-	-	-	-	
Electrical system	Defective starter switch	-	-	-	-	o	-	o	-	-	-	-	-	-	-	-	-	-	
	Defective starter magnetic switch	-	-	-	-	o	-	-	-	-	-	-	-	-	-	-	-	-	
	Defective starting motor	-	-	-	o	o	-	-	-	-	-	-	-	-	-	-	-	-	
	Defective starting motor free wheel	-	-	-	o	o	-	-	-	-	-	-	-	-	-	-	-	-	
	Defective flywheel ring gear and pinion	-	-	-	o	o	-	-	-	-	-	-	-	-	-	-	-	-	
	Battery voltage drop	-	-	o	o	o	-	o	-	-	-	-	-	-	-	-	-	-	
	Open circuit in heater plugs or pilot lamp	-	-	o	-	-	-	o	-	-	-	-	-	-	-	-	-	-	
	Short circuit in heater plugs	-	-	o	-	-	-	o	-	-	-	-	-	-	-	-	-	-	
	Defective alternator	-	-	-	-	-	-	-	-	-	-	-	-	-	-	-	-	-	
	Defective alternator relay	-	-	-	-	-	-	-	-	-	-	-	-	-	-	-	-	-	
	Improper wiring	-	-	o	o	o	-	o	-	-	-	-	-	-	-	-	-	-	
Main moving parts	Jammed moving parts	-	-	-	o	-	-	-	-	-	-	-	-	-	-	-	-	-	
	Worn cylinders, pistons or piston rings	-	-	o	-	-	-	-	-	o	-	o	-	-	o	-	-	-	
	Sticking piston rings	-	-	o	-	-	-	-	-	o	-	o	-	-	o	-	-	-	
	Excessive main bearing clearance	-	-	-	-	-	-	-	-	-	-	-	-	o	-	-	-	-	
	Loose connecting rod cap bolts	-	-	-	-	-	-	-	-	-	-	-	-	o	-	-	-	-	
	Interference between valve and piston	-	-	-	-	-	-	-	-	-	-	-	-	o	-	-	-	-	
	Broken valve springs	-	-	o	-	-	-	-	-	o	-	o	-	-	o	-	-	-	
	Excessive valve clearance	-	-	-	-	-	-	-	-	-	o	-	-	-	o	-	-	-	
	Foreign substances in cylinders	-	-	-	-	-	-	-	-	-	o	-	-	-	o	-	-	-	
	Excessive gear backlash	-	-	-	-	-	-	-	-	-	-	-	-	-	o	-	-	-	

(● For detailed information refer to the separate chart.)

Engine vibrates excessively	Engine stalls	Poor response for deceleration	Engine does not pick up speed	Engine operates at high speeds but fails to stop	Engine turns in reverse direction	Excessive fuel consumption	Excessive oil consumption	Oil is diluted by fuel	Water in oil	Excessive blow-by	Defective lubrication system			Abnormal water temperature rise		Defective alternator		Remedy	
											When engine stops, warning lamp does not come on	Warning lamp comes on at low-speed operation	Warning lamp comes on at high-speed operation	Water temperature too high (Engine overheats)	Water temperature too low	Indicator lamp does not come on when engine stops	Indicator lamp comes on at high-speed operation		
																			Heat oil pan from bottom side at starting. After starting, warm up engine thoroughly.
	○																		●
																			●
																			●
									○										Retighten and replace gasket if necessary.
																			Replace crankcase.
																			Check for connections and repair. Replace if necessary.
																			Repair or replace if necessary.
																			Repair or replace.
																			Repair or replace motor if necessary.
																			Repair or replace ring gear. Replace pinion.
																			Recharge or replace battery. If necessary heat it.
																			Replace.
																			Replace copper packings and if necessary heater plugs.
																			○ Replace alternator if necessary.
																			○ Adjust or replace.
																			— Connect wires properly.
	○																		●
																			Repair or replace.
																			Repair or replace.
																			Check and replace bearing(s) with undersize one(s) if necessary.
																			Retighten.
																			Re-time timing gear train or adjust valve sinkage properly.
																			Replace.
																			Adjust valve clearance to 0.25 mm (0.0098 in.).
																			Repair.
																			Replace gears or idler bushing.

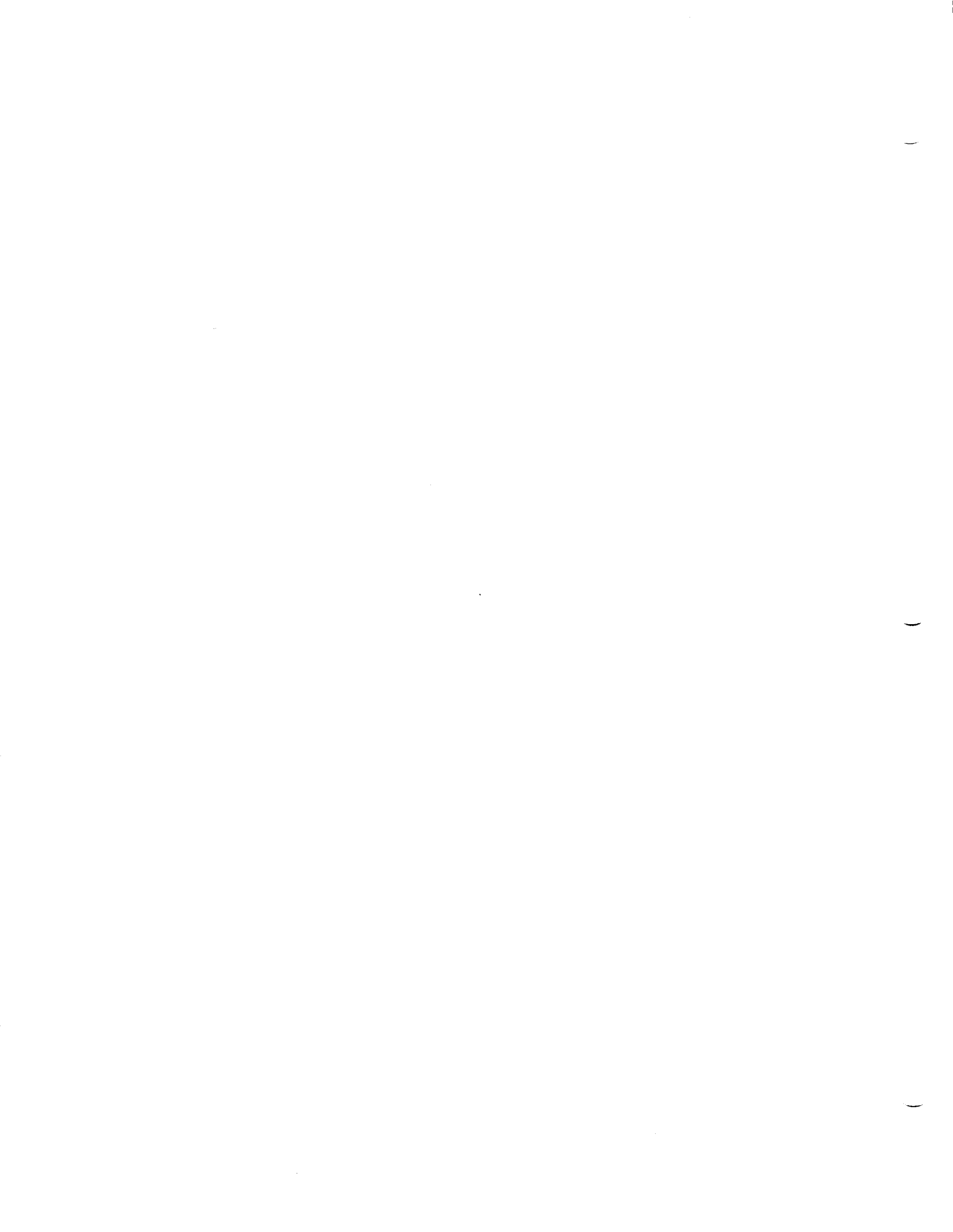

**Mitsubishi 4DQ5
Diesel Engine
Service Manual
Supplement**

**Fuel System
Reelmaster[®] 450-D**



FUEL SYSTEM

	Page
Description	85
Fuel filter	
Description	86
Removal and installation	86
Disassembly and reassembly	86
Inspection	87
Fuel injection pump (DPA)	
Description	88
Removal and installation	97
Idling and maximum speed adjustments	97
Fuel injection nozzles	
Description	98
Removal and installation	98
Disassembly and reassembly	98
Inspection	99
Testing and adjustment	99

DESCRIPTION

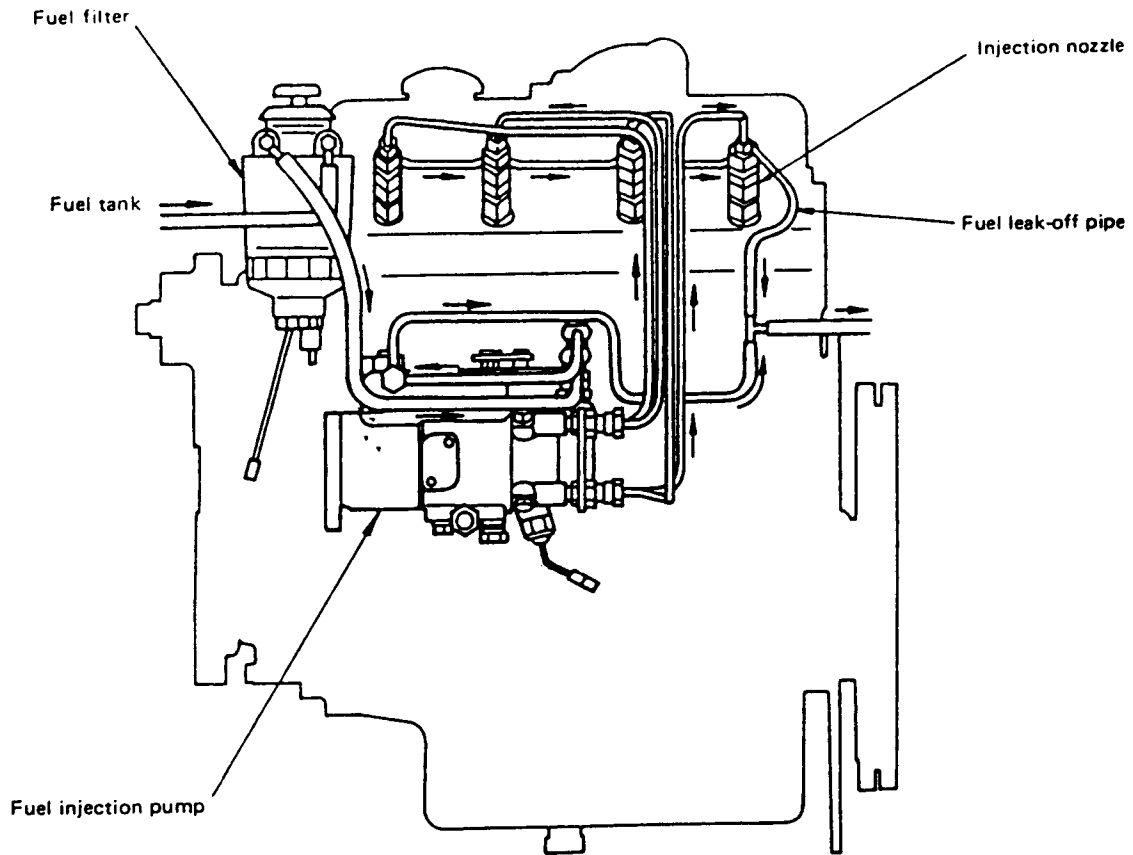

(Arrows show fuel flow in the circuit.)

Fuel circuit

The fuel system consists of fuel tank, fuel filter, fuel injection pump, injection pipes, injection nozzles and leak-off pipe, as shown.

The fuel is fed from the fuel tank to the injection pump through fuel filter. The injection pump delivers high-pressure fuel through injection pipes to the injection nozzles, from which it is injected into the cylinders.

Specifications

Injection pump	Distributor type (DPA)
Injection nozzle	Throttle type
Fuel filter	Paper-element type

FUEL FILTER

Description

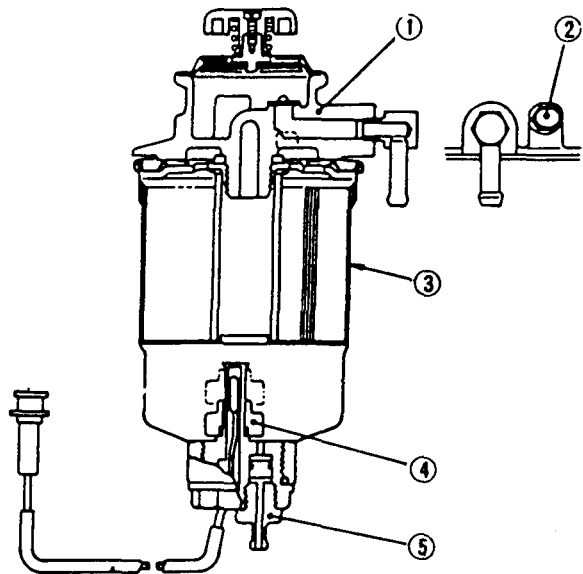

- | | |
|-------------------------------------|----------------------|
| 1-Body assembly (with priming pump) | 4-Water level sensor |
| 2-Air plug | 5-Drain plug |
| 3-Cartridge filter | |

Fuel filter – Sectional view

The fuel filter is equipped with a diaphragm type priming pump built in its top section and a sedimenter (water separator). In the bottom section of the filter is built in a water level sensor which detects settlement of moisture in the filter and sends it as an electric signal to the warning lamp of OK monitor.

Removal and installation

Removal sequence

- (1) Drain plug ① (Drain fuel.)
- (2) Fuel hose ②
- (3) Water level sensor connector ③
- (4) Fuel filter ④

NOTES

- a) When disconnecting fuel hose, wrap the disconnected end with cloth to prevent fuel from spilling out.
- b) Install a blind plug to the disconnected end of hose to prevent fuel from spilling out and dirt from getting inside.

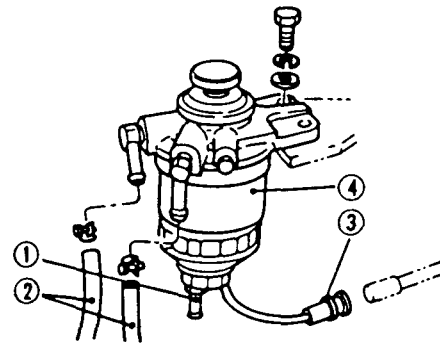

Removing fuel filter

Installation sequence

- (1) Follow the reverse of removal sequence.
- (2) Prime the fuel system (referring to the topic, Priming fuel system).

Disassembly and reassembly

Disassembly sequence

- (1) Body assembly ①
- (2) Water level sensor ②
- (3) Cartridge filter ③

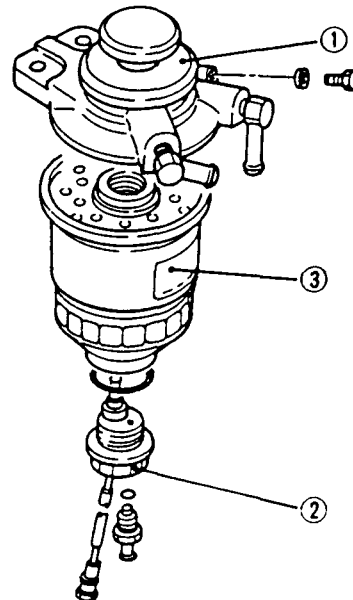

Disassembling fuel filter

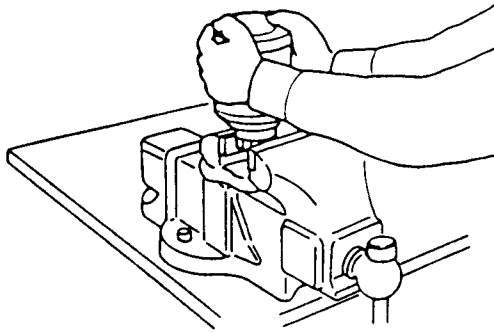

Removing water level sensor

Reassembly sequence

Follow the reverse of disassembly sequence.

Priming fuel system

- (1) Loosen the air plug at the top of fuel filter. Cover the plug with cloth, and operate the priming pump until fuel flows without bubbles.
- (2) Tighten the air plug, check the filter for fuel leaks, and operate the pump until resistance is encountered.

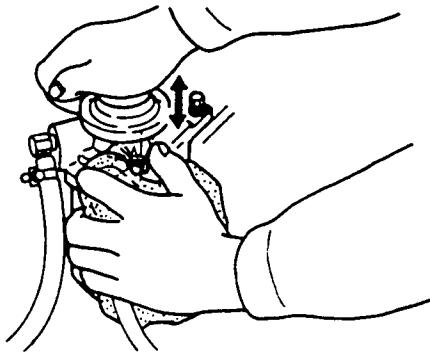

Priming fuel system

Draining moisture

- (1) Connect a 6-mm (1/4-in.) hose to the drain plug at the bottom of fuel filter.
- (2) Loosen the drain plug, and operate the priming pump (about 7 strokes), and tighten the plug.

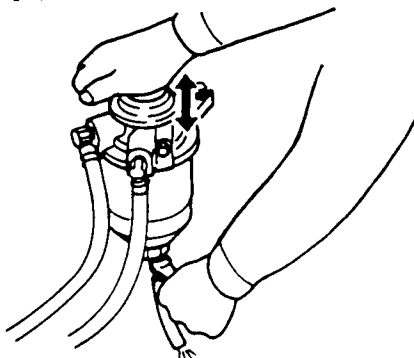

Draining moisture

Inspection

- (1) Replace the element after every 6 months or 1200 operating hours.



Do not wash paper element.

- (2) Replace the packings and other sealing parts at the time of disassembling filter.
- (3) Check the body assembly for cracks, distortion, stripped threads and other defects, and replace it if defective.
- (4) Replace the plugs if their threads are stripped.
- (5) Check to make sure that the warning lamp glows when the float of water level sensor is moved upward, the connector kept connected.

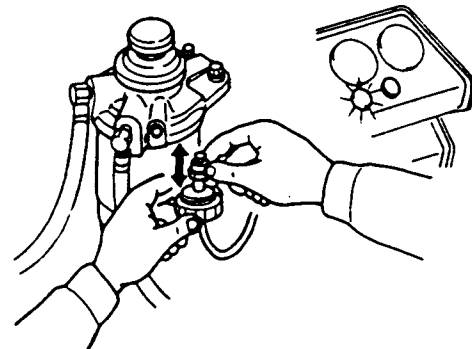

Checking water level sensor

FUEL SYSTEM

FUEL INJECTION PUMP (DPA)

Description

The DPA injection pump is a distributor type pump consisting of a transfer pump, fuel pumping plunger, distributing device, automatic advance, mechanical governor and control linkage, which are built in a compact, lightweight pump housing. Functionally, this pump features a pair of pumping plunger for metering and delivering fuel.

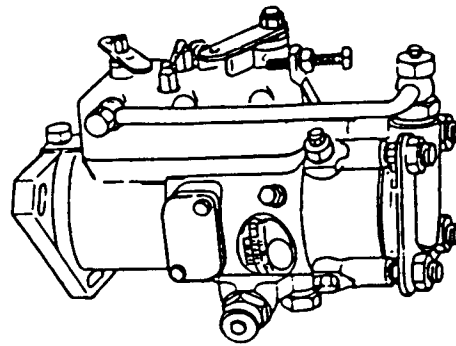

DPA fuel injection pump

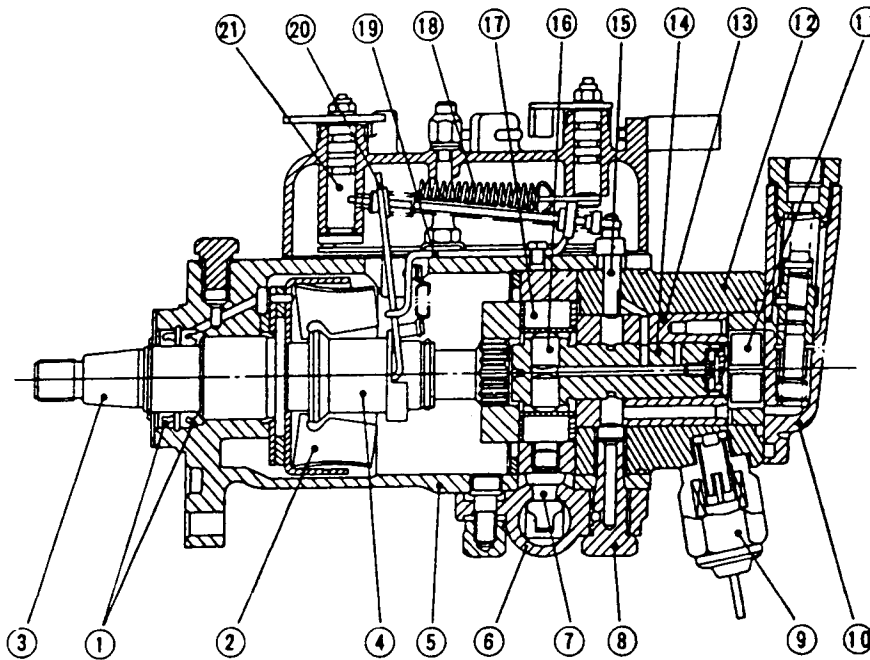

- | | | |
|---------------------|---------------------------------|-------------------------|
| 1-Drive hub seal | 8-Head locating stud | 15-Metering valve |
| 2-Governor weight | 9-Shut-off solenoid valve | 16-Plunger |
| 3-Drive shaft | 10-End plate (regulating valve) | 17-Cam roller |
| 4-Thrust sleeve | 11-Transfer pump | 18-Governor spring |
| 5-Pump housing | 12-Head & rotor assembly | 19-Governor arm bracket |
| 6-Automatic advance | 13-Hydraulic head | 20-Governor arm |
| 7-Cam advance screw | 14-Rotor | 21-Shut-off shaft |

DPA fuel injection pump – Sectional view

Pumping and distributing principle

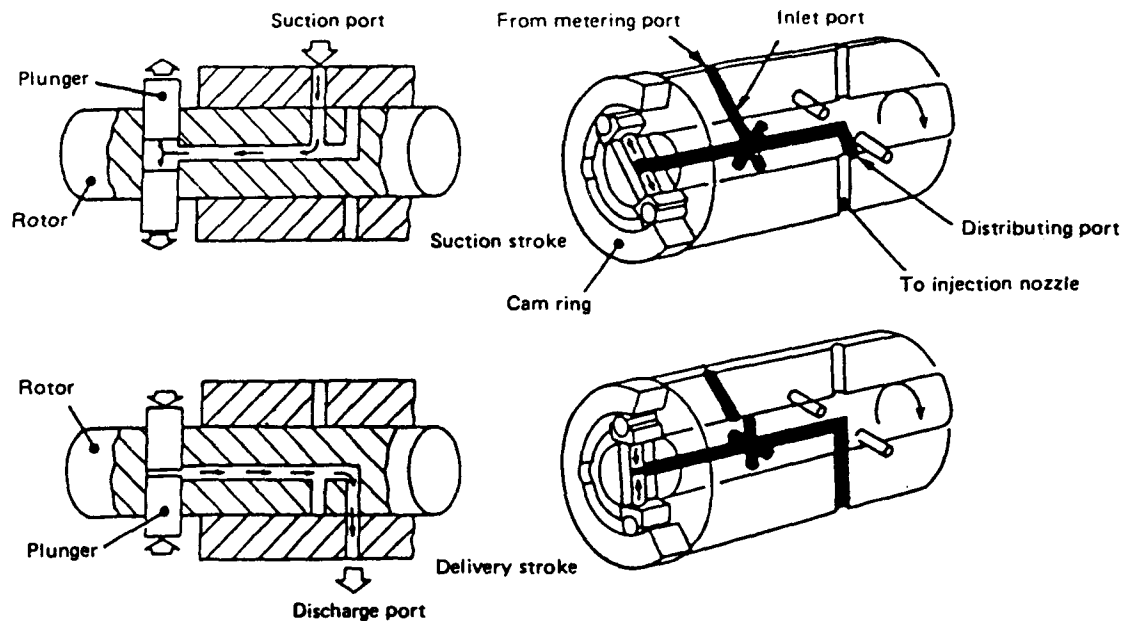

Pumping and distributing principle

The rotor has a center fuel passage communicating to the cylinder of plunger pump and a radial distributing port.

The hydraulic head, in which the rotor revolves, has radial outlet ports equally spaced and leading to the injectors through high-pressure pipes. As the rotor revolves, its radial port comes over the radial outlet ports of hydraulic head one by one to force out the fuel. On the distributing-port side of the rotor is mounted the rotor of a vane-type transfer pump. The pump liner of this pump is installed to the hydraulic head and covered with an end plate. The end plate has an inlet connection and a built-in regulating valve for limiting the transfer pump discharge pressure.

Fuel entering the inlet connection is delivered by the transfer pump to the metering port of hydraulic head through the regulating valve, the passage in hydraulic head and the groove located close to plunger pump.

The port diagonally drilled in the hydraulic head is a metering port communicating to the metering valve through the diagonal port of head & rotor assembly. The inlet side of the metering port acts as a metering orifice which is adjusted by the metering valve.

Regulating valve

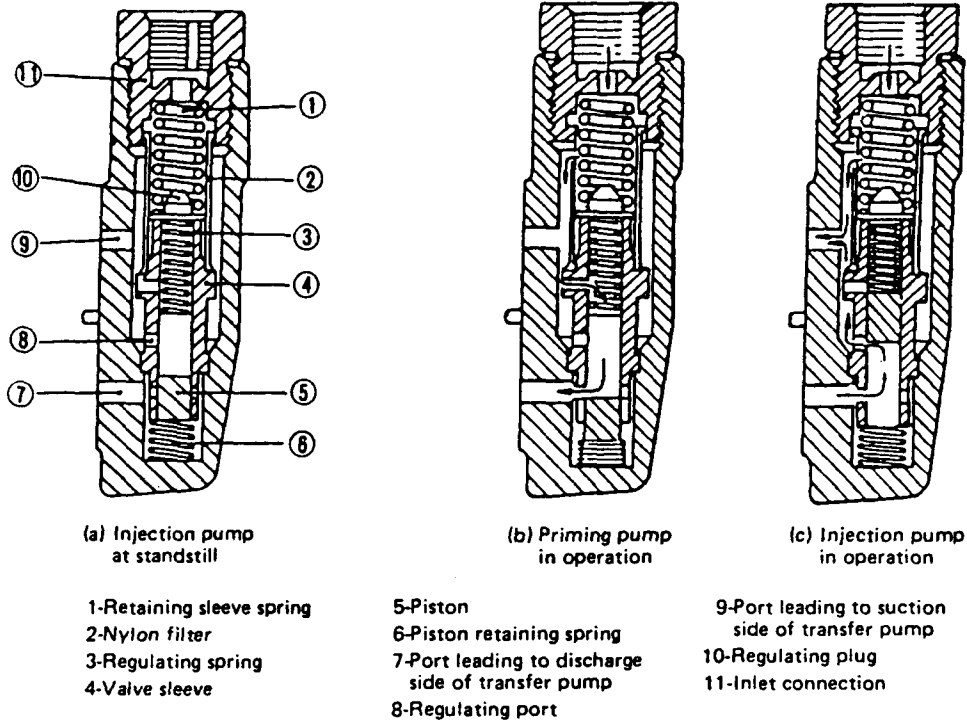

Regulating valve action

The regulating valve built in the end plate serves two functions:

- (1) To limit the transfer pump discharge pressure in order to balance the pressure and pump speed.
- (2) To allow fuel to bypass the transfer pump for flowing direct to the passage of hydraulic head when the pump is not operated.

When the pump is at standstill, no pressure acts on the end plate as shown in Fig. (a). In the priming position shown in Fig. (b), pressure developed by the priming pump acts on the piston to push it downward, opposing the force of piston retaining spring. Under this condition, the port leading to the discharge side of transfer pump is uncovered, and fuel bypasses the transfer pump at standstill and flows to the hydraulic head. Fig. (c) shows the regulating valve in action. In this position, the piston is being pushed upward by the pressure developed by the transfer pump to keep the regulating port uncovered. The fuel pressure now acts on the regulating spring through the piston in such a manner that a condition of equilibrium is sought by the two forces. The transfer pump pressure varies with the force of regulating spring.

Metering valve

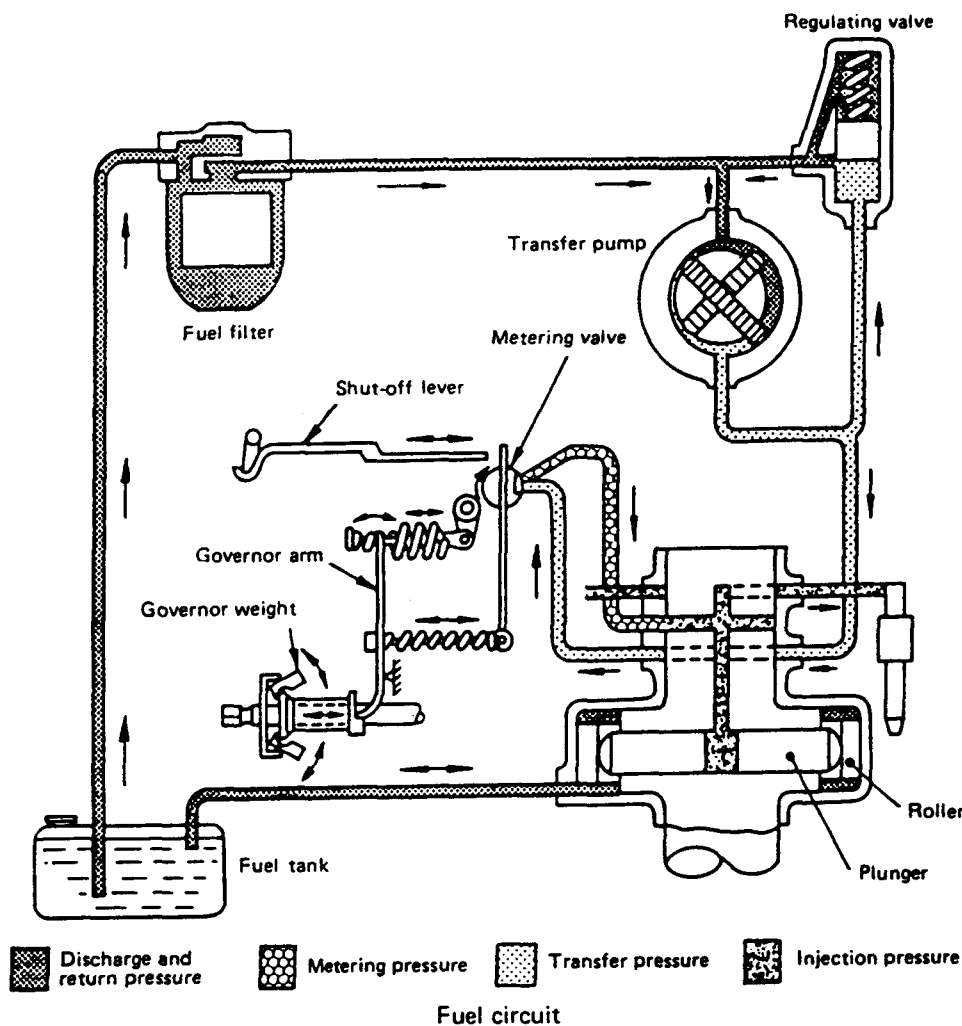

The metering valve is located on the hydraulic head and has a linkage connected to the throttle lever and the arm of governor (mechanical).

This valve is of rotary type and has an axial groove on its periphery. As the valve is rotated by the throttle lever or the governor arm. The groove changes its position with respect to the metering port to provide a metering action.

It is by this metering action that the amount of fuel entering the plunger pump during suction stroke is controlled. The amount of fuel is determined by the opening of orifice, the length of time of suction stroke and the transfer pressure.

Fuel is fed to the transfer pump with "feed pressure" and is delivered from the pump with "transfer pressure." The transfer pressure increases with an increase in the pump speed; it drops to the minimum level when the pump is at idling speed.

If the engine speed is increased with the throttle lever

set in a given speed position, the governor acts to control the injection quantity automatically regardless of the throttle lever position.

Injection quantity control

The injection quantity is controlled by varying the amount of plunger stroke. The cam rollers are held in place by the roller shoes which are in contact with the plungers and slide in the guide grooves formed of the rotor.

Each roller shoe has a "lug" which is fitted in the eccentric grooves formed of the top and bottom adjusting plates holding the rotor. The top and bottom adjusting plates are located in place by the bent portion of the top adjusting plate.

The top adjusting plate is secured by two drive plate screws in between the end of rotor and the drive plate. These screws extend through the oblong holes in the adjusting plate; loosening the screws make it possible to move the adjusting plate.

FUEL SYSTEM

The outward stroke of plungers is maximized when the lugs of roller shoes come to the curved sides of the eccentric grooves of the adjusting plate.

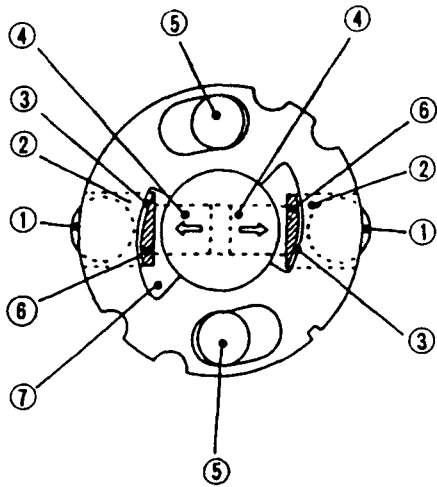

- 1-Cam rollers
- 2-Roller shoes
- 3-Clearance between adjusting plate
* groove and roller shoe lug
- 4-Plunger
- 5-Drive plate screws
- 6-Roller shoe lugs
- 7-Eccentric groove in adjusting plate

Injection quantity control mechanism

Shut-off solenoid valve

This valve is controlled by the engine starter switch. In "ON" position of the starter switch, it opens the fuel passage leading to the suction port of the cylinder. In "OFF" position of the switch, it closes the fuel passage.

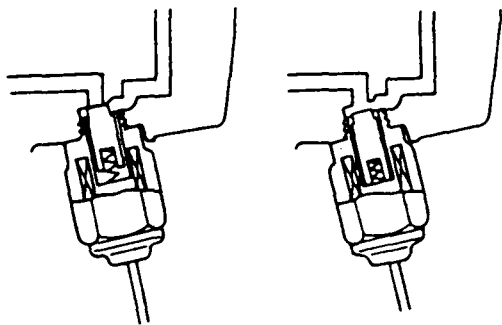

Engine stopped Engine running
Shut-off solenoid valve

Governor

This mechanical governor is constructed as shown. The governor weights are pinned to the weight retainer fitted to the drive shaft. The drive hub and drive shaft rotate together in operation. One side of each weight has its bell-crank portion abutting to the thrust sleeve, so that the expanding motion of the weights causes the sleeve to move on and along the drive shaft.

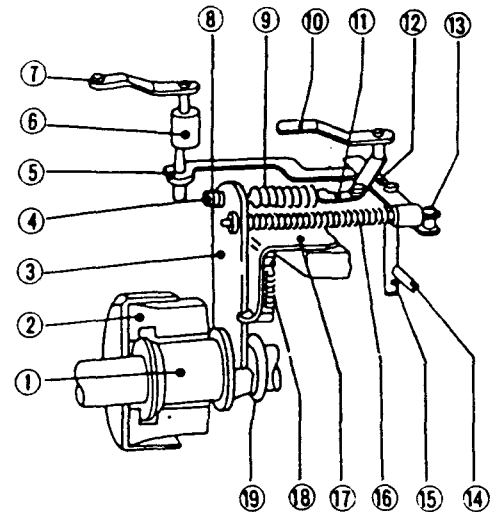

- 1-Thrust sleeve
- 2-Governor weight
- 3-Governor arm
- 4-Idling spring guide
- 5-Shut-off bar
- 6-Shut-off shaft
- 7-Shut-off lever
- 8-Idling spring
- 9-Governor spring
- 10-Throttle lever
- 11-Throttle shaft link
- 12-Metering valve lever
- 13-Linkage hook
- 14-Metering port
- 15-Metering valve
- 16-Linkage spring
- 17-Governor arm bracket
- 18-Governor arm spring
- 19-Drive shaft

Mechanical governor

The governor arm has a pivot point at the knife-edge portion of governor arm bracket and is connected to the thrust sleeve on one end and to the linkage hook for rotating the metering valve on the other. The arm is spring-loaded by a tension spring called governor spring. The tension of this spring opposes the force of thrust sleeve due to centrifugal force of the weights in such a manner that, for a given setting of the throttle lever, a condition of equilibrium is sought by the two forces.

As the throttle lever is moved in such a direction of pulling the governor spring (of increasing the engine speed), the tension of governor spring overcomes the force of thrust sleeve due to centrifugal force to rotate the metering valve in the direction of increasing the injection quantity. When the engine speed increases and the centrifugal force overcomes the tension of the spring, the thrust sleeve is moved back to the position where the two forces balance with each other for steady-state speed regulation.

Exactly, the governor arm is loaded by two springs, governor spring and idling spring, which are installed across the arm. Except when the engine is idling, the force of idling spring does not act on the arm. When the engine is idling, the idling spring takes the place of governor spring to keep the steady idling speed. This idling spring is provided with an adjusting screw for varying the idling and maximum rpm.

The eccentric shaft located below the shut-off shaft moves the metering valve lever through shut-off bar. As the shut-off shaft is rotated, the metering valve is closed regardless of the throttle lever.

Automatic advance

In full-load operation of the engine, the cam rollers move to the outermost ends of the grooves in the adjusting plate and come in contact with the inside lugs of the cam ring.

In light-load operation, only the amount of fuel just enough to move the cam rollers to the middle points of the adjusting plate grooves is fed to the plunger cylinder. Under this condition, the cam rollers come in contact with the upper portions of the lugs to advance the injection timing (beginning of the injection) according to the engine speed. This action takes place because the injection timing is more retarded in light-load operation than in full-load operation.

The cam advance screw is fitted to the piston on one side and to the cam ring on the other. The movement of the piston is transmitted through this screw to the ring to rotate the ring in either direction. This piston is loaded by a spring on one side toward the position in which the injection timing is most retarded.

Fuel under transfer pressure enters the side of automatic advance housing opposite to the spring through the passage in the bolt. In the pump housing, the transfer pressure and spring force balance with each other across the piston. As the engine speed increases and the transfer pressure rises, the piston is moved, against the spring force, to rotate the cam ring counterclockwise for advancing the injection timing.

As the engine speed reduces and the transfer pressure drops, the piston is pushed by the spring to force fuel out of the cylinder through the passage between the cylinder and piston to retard the injection timing.

The cam ring tends to rotate in the direction of retarding the injection timing at the beginning of injection. This can be prevented by installing a non-return valve in the fuel passage to the automatic advance.

The advance range of the pump is 12 deg.; this range can be varied by adjusting the spring tension to meet a given engine speed.

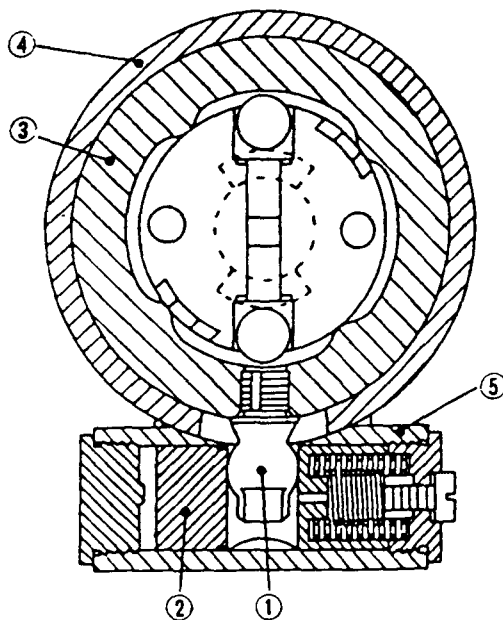

- | | |
|---------------------|-----------------------------|
| 1-Cam advance screw | 4-Pump housing |
| 2-Piston | 5-Automatic advance housing |
| 3-Cam ring | |

Automatic advance

Self-vent mechanism

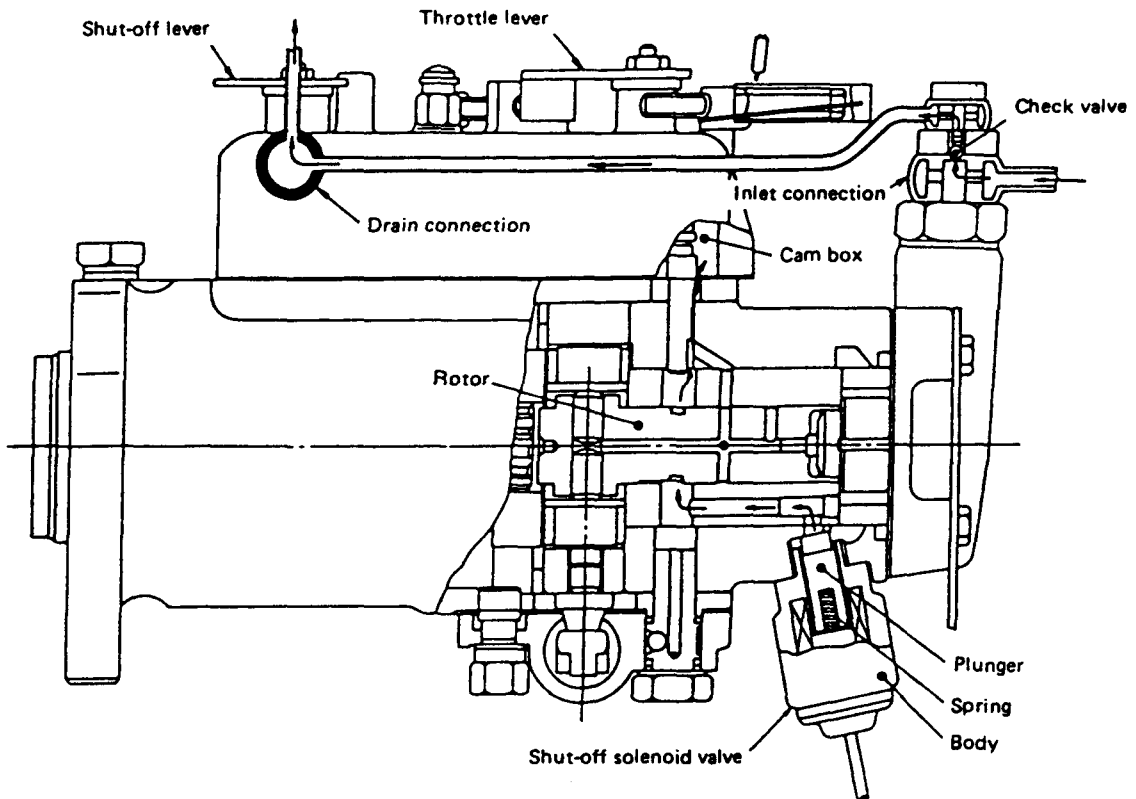

Self-vent mechanism

The fuel system can be primed for venting air by operating the priming pump.

Air trapped in the circuit between the fuel tank and the injection pump suction side can be carried through the check valve to the drain connection for venting. Air in the injection pump is carried through the metering valve groove to the cam box for venting.

After the engine has been started, the transfer pump built in the injection pump draws fuel. Under this condition, the pressure in the circuit between the filter and injection pump drops to close the check valve to prevent air from entering the injection pump.

A small amount of air entering the injection pump during operation is carried through the metering valve groove to the cam box for venting.

Tabulated data of DPA injection pump

Model	4DQ5	S4E, S4E2
Cam lift	1.5 mm (0.06 in.) one side	
Plunger diameter	6.5 mm (0.26 in.)	7 mm (0.28 in.)
Injection order	1-3-4-2	
Injection interval	90°	
Maximum cam rate	0.120 mm (0.005 in.)/deg	
Advance angle	2 deg in pump angle	
Steady speed regulation	7%, max.	
Maximum governor set speed	1200 rpm	

Cold advance device

Description

The cold advance device provides a means of advancing the injection timing just after the engine is started in cold state in order to prevent it from emitting white exhaust smoke during warm-up period.

• **Thermal switch**

This switch is located at the outlet port of water jacket of the engine, just ahead of the thermo valve. It detects the coolant temperature for controlling the solenoid valve.

• **D-C solenoid valve**

This valve, when opened by the thermal switch, lets the signal pressure escape through the valve body.

• **Cold advance piston**

The cold advance piston (A) is larger than the advance piston (D) as far as the pressure area is concerned. As the signal pressure is applied to the piston (A), this piston moves the piston (D) until it is limited by the adaptor (H) to keep the injection timing for normal engine operation. When the signal pressure acting on the piston (A) drops, the piston is moved back by the piston (D) to cold-advance the timing.

• **Orifice and check valve**

During cold advance of the injection timing, the fuel flows to the cam box through the solenoid valve. In this circuit is located the orifice to throttle the flowrate of fuel to prevent the transfer pressure from dropping. As the starter switch is turned OFF position and the signal pressure acting on the piston (A) drops, the piston is returned by the force of retard spring (C), forcing the fuel back to the injection pump. This is the reason why the check valve is located in this circuit to prevent such a reverse flow of fuel for making it easy to stop the engine. The orifice and check valve are built in the banjo bolt assembly.

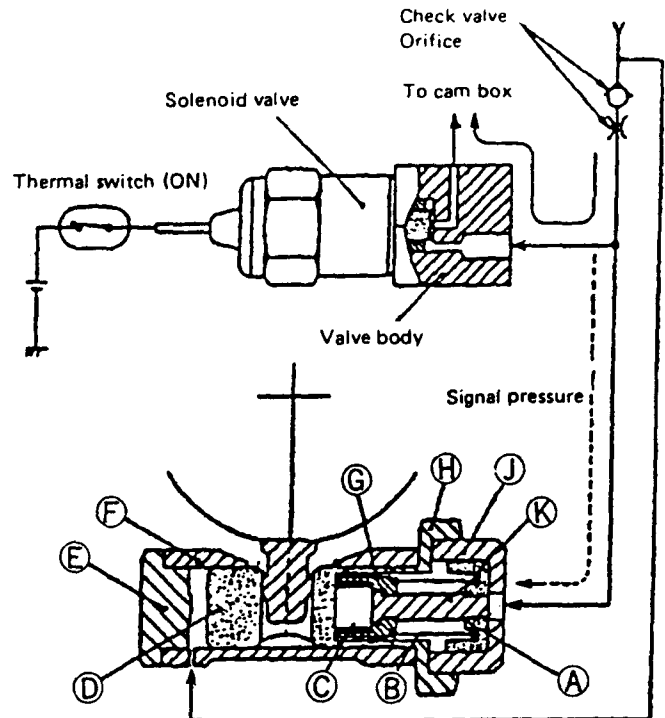

- | | |
|-----------------------|-------------------|
| A-Cold advance piston | F-Advance housing |
| B-Advance spring | G-Spring retainer |
| C-Retard spring | H-Adaptor |
| D-Advance piston | J-Cap |
| E-End plug | K-Rod |

Cold advance action (before warm-up)

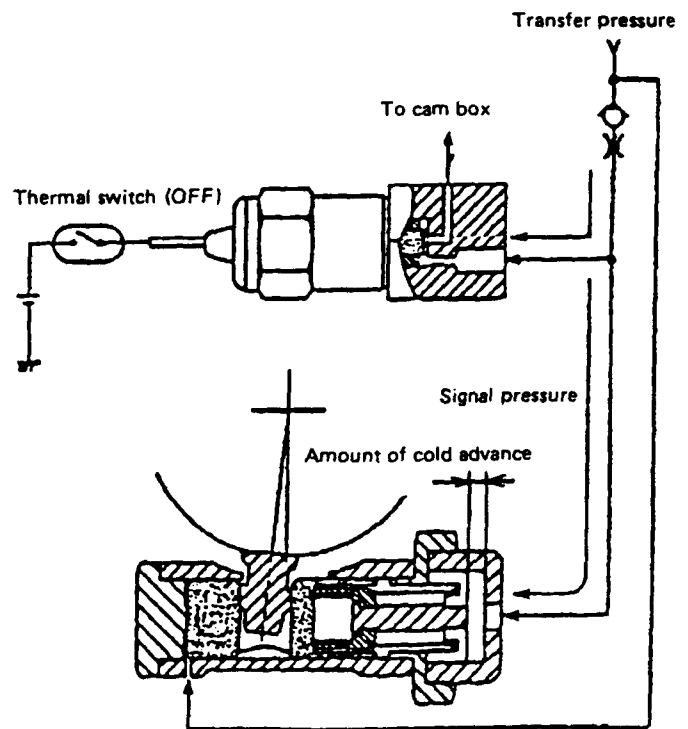

Cold advance action stopped (after warm-up)

• Operation

1) Engine stopped

The pistons (A) and (D) are being pushed all the way outward by the force of retard springs.

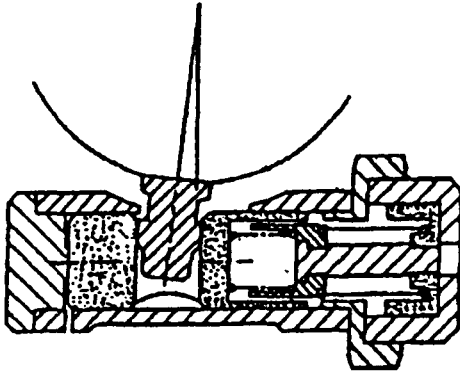

When engine stopped

2) Cold advance action (before warm-up)

As the starter switch key is turned ON, the thermal switch is turned on to open the solenoid valve. When the engine starts with the solenoid valve open, the transfer pressure (TP) rises to move the piston (D) in the direction of advancing the

injection timing. On the other hand, the signal pressure for piston (A) escapes through the valve body (opened) to the cam box. Under this condition, the pistons (A) and (D) are pressed toward the right side to advance the injection timing for the engine being warmed up. The characteristic curve of this cold advance action is as shown below.

3) Cold advance action stopped (after warm-up)

As the coolant temperature reaches about 60°C (140°F), the thermal switch is turned off to close the solenoid valve, causing the signal pressure to rise. Because the transfer pressure is nearly equal to the signal pressure, the piston (A) moves back the piston (D) until it is limited by the adaptor (H) to switch cold-advance action to normal-advance action.

As the engine speed increases in normal-advance action, the transfer pressure rises. Under this condition, the piston (D) moves in such a direction as to advance the injection timing, pushing the spring retainer (G) and compressing the spring (B).

As long as the coolant temperature is above 50°C (122°F), the thermal switch is kept off even if the engine is stopped and no cold-advance action takes place when the engine is restarted.

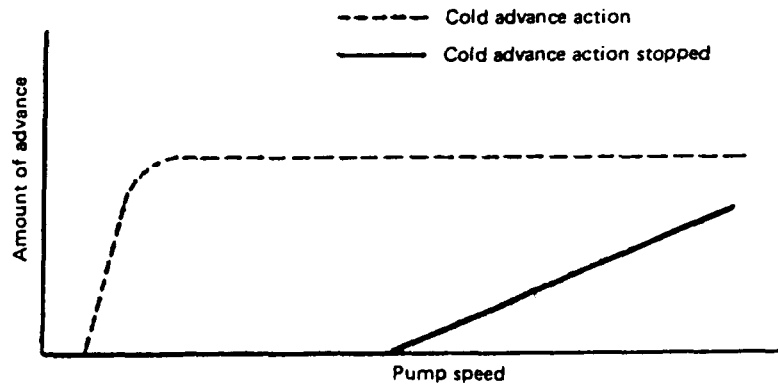

Cold advance characteristic curve

Removal and installation

Removal

Bring the No. 1 cylinder piston to top dead center on compression stroke, check the mesh of injection pump drive gear with the idler gear, and remove the injection pump.

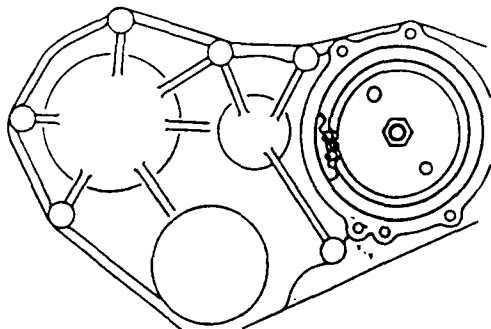

Installation

Install the injection pump to the engine front plate by aligning the marks on the pump and flange plate on one hand and the marks on the injection pump drive gear and idler gear on the other.

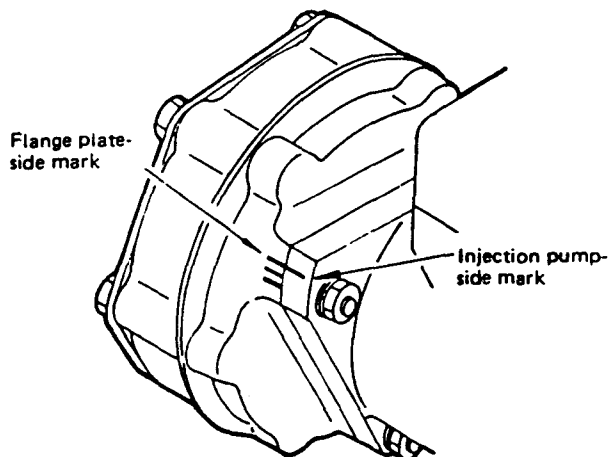

Air venting (when fuel tank runs empty or injection pump is replaced)

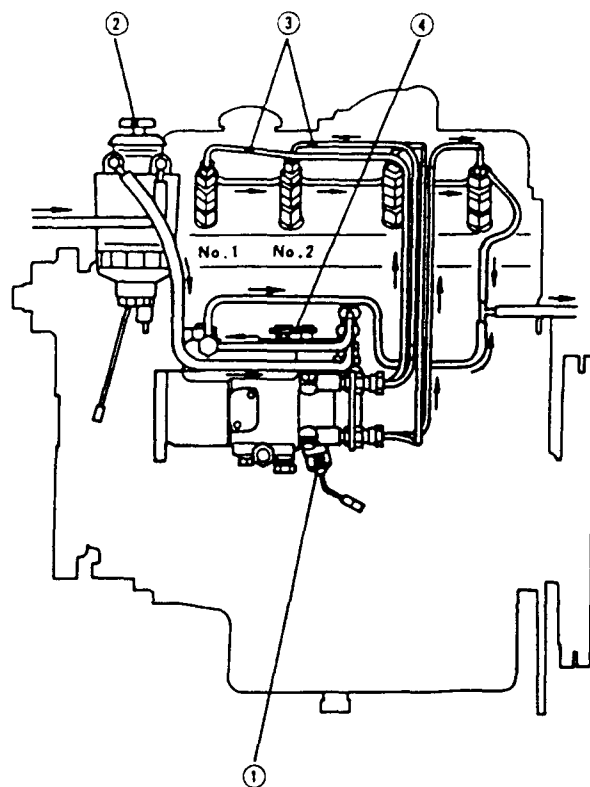

Air venting

- (1) Turn the starter switch to "ON" position to operate shut-off valve ①.
- (2) Operate priming pump ② (about 20 times) to feed fuel.
- (3) Loosen the nuts of injection pipes ③ (for No. 1 and No. 2 cylinders).
- (4) Move throttle lever ④ to the maximum speed position.
- (5) Crank the engine by means of the starter, and tighten the nuts loosened in step (3) above when fuel flows without bubbles from the nozzle side.
- (6) With the throttle lever in the maximum speed position, start the engine, and run the engine at idle speed for 30 to 60 seconds.

Idling and maximum speed adjustments

After installing the injection pump on the engine, be sure to adjust the idling and maximum speeds.

- (1) Start the engine, and reposition the throttle lever on the top of control cover by means of adjusting screw ① so that the idling speed is 800 to 850 rpm.

FUEL SYSTEM

- (2) With the throttle lever kept in contact with adjusting screw (2), reposition the lever by means of adjusting screw (2) so that the maximum speed is 2900 to 2950 rpm.

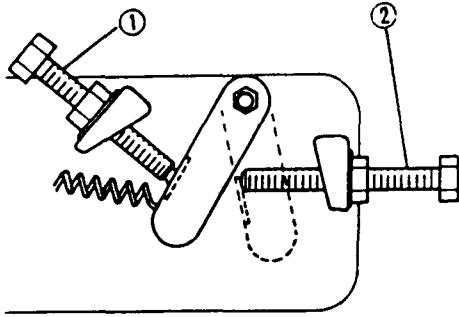

FUEL INJECTION NOZZLES

Description

The injection nozzle provides a means of spraying into the precombustion chamber the fuel oil delivered under pressure from the injection pump. It sprays oil out in a conical pattern consisting of finely atomized droplets of oil. The mating surfaces of the nozzle holder body, distance piece and nozzle are precision-finished to form an oil-tightness.

The injection pressure adjustment may be made by means of adjusting washer. Increasing the thickness of the washer will increase the spring tension and, hence, the injection pressure, and vice versa.

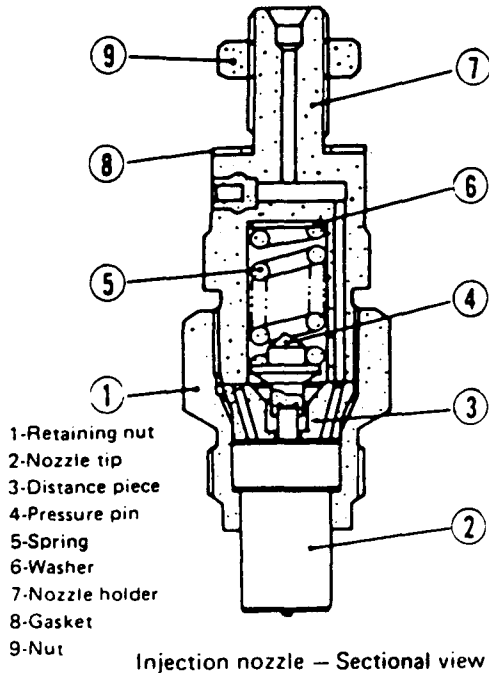

Removal and installation

Removal sequence

- (1) Connectors (1) (4 pcs)
- (2) Fuel feed pipes (2)
- (3) Fuel return pipe (3)
- (4) Fuel leak-off pipe (4) (nuts (5) 4 pcs)
- (5) Fuel injection nozzle assemblies

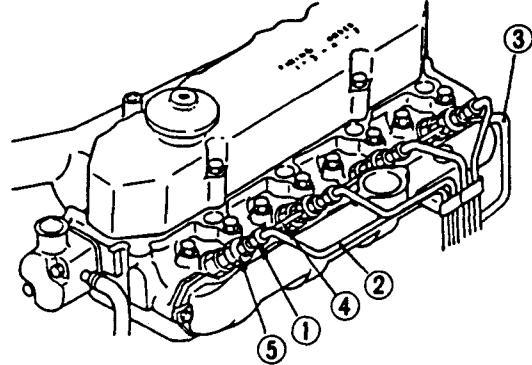

Installation sequence

Follow the reverse of removal sequence.

Unit: kg-m (lb-ft)

Fuel injection nozzle tightening torque	5 ± 0.5 (36.2 ± 3.6)
---	-------------------------

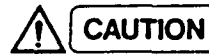

After removing injection nozzles, be sure to cover disconnected ends of injection pipes and nozzle holes in cylinder head to prevent entry of dirt.

Disassembly and reassembly

NOTE

Before disassembly, collect data on the nozzle by testing it for injection pressure (beginning of injection), spray pattern and internal oil-tightness, all in the manner already described. Throughout the disassembly, cleaning and reassembly work, handle each nozzle assembly with care to protect, in particular, the nozzle tip.

Disassembly sequence

- (1) Retaining nut ① (Hold it in a vise.)
- (2) Nozzle holder ②
- (3) Nozzle tip ③
- (4) Distance piece ④
- (5) Pressure pin ⑤
- (6) Spring ⑥
- (7) Washer ⑦

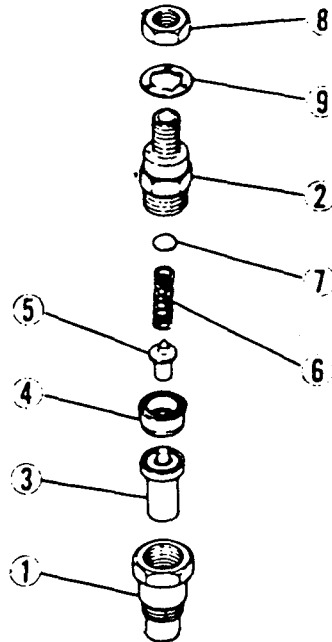

- 1-Retaining nut
- 2-Nozzle holder
- 3-Nozzle tip
- 4-Distance piece
- 5-Pressure pin
- 6-Spring
- 7-Washer
- 8-Nut
- 9-Gasket

Injection nozzle assembly – Disassembled view

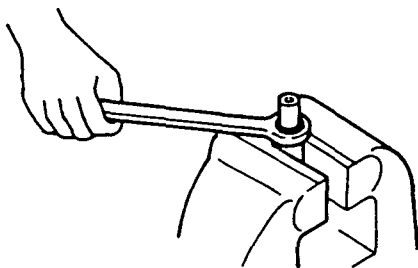

Disassembling nozzle holder

Reassembly sequence

Follow the reverse of disassembly sequence.

NOTE

If the needle valve and nozzle proper have to be replaced, be sure to wash the replacement parts in the pool of kerosene after removing their protective film of plastic; wash off the rust-preventive oil from the nozzle proper by stroking the needle valve back and forth in the needle valve stem bore.

Inspection

(1) Needle valve and nozzle body

- (a) Immerse needle valve and nozzle body in a pool of clean kerosene, insert the valve into the body, and move the valve back and forth to be sure that the sliding contact is smooth without evidencing any excessive clearance. The injection nozzle as a whole must be replaced if the fit is found defective.
- (b) Visually examine the nozzle body with a magnifying glass having a power of 4 or 5.
- (c) Inspect the needle valve for distortion or damage at its seating part and for wear of its end face in contact with the pressure pin.
- (d) Poor seating contact may be corrected, if the defective condition is not advanced too far, by lapping the valve against the seat with a coat of clean lube oil applied to the seating faces. If this does not help, the injection nozzle must be replaced.

(2) Nozzle holder and distance piece

Check the fit between nozzle holder and distance piece. Determine the quality of the fit from contact patterns obtained with the use of red lead paste: defective fit will be evidenced by an abnormally high rate of return oil (leak-off) flow.

(3) Pressure spring and pressure pin

- (a) Replace any pressure spring broken, cracked or otherwise defective, or out of square. Inspect each spring for these defects.
- (b) Inspect each pressure pin for wear at its end faces, one for pressure spring and the other for needle valve.

(4) Leak-off pipe packing

If the packing is found in deteriorated condition, replace it.

Testing and adjustment

(1) Injection pressure

The pressure at which the needle valve unseats itself against the force of the pressure spring is referred to as "valve opening pressure" or "beginning-of-injection pressure," but will be called here "injection pressure" for short. The value of this pressure is specified; it is checked and adjusted as follows:

- (a) Install the injection nozzle in the nozzle tester, and operate the manual pumping handle of the tester several strokes to prime the nozzle.

- (b) Move the lever up and down slowly, completing each up-and-down cycle in about a second, to pressurize the injection nozzle, while observing the indication of the test pressure gauge. As the nozzle begins to spray, the indicating pointer of the gauge being deflected will start perceptively oscillating: read the pressure right then as the injection pressure.

Specifications Unit: kg/cm² (psi)

Item	Standard	Repair limit
Injection pressure	120^{+10}_0 (1706.4 ^{+142.2} ₀)	110 (1564.2), max

- (c) If the reading taken is below the limit, increase the thickness of the shim used on the pressure spring. Increasing the shim thickness by 1 mm (0.04 in.) raises the injection pressure by about 10 kg/cm² (142 psi). Adjusting shim stock for this purpose is available in 20 sizes, from 1.0 mm (0.0394 in.) up to 1.95 mm (0.0768 in.) in increments of 0.05 mm (0.0020 in.) each.

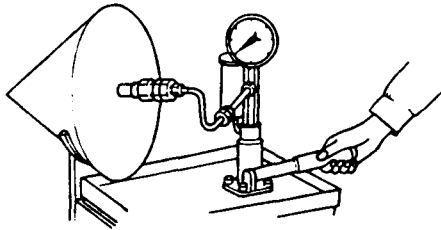

Checking injection pressure on nozzle tester

(2) Spray pattern

The injection nozzles used in the present engine are of throttle type. Some throttling action takes place when the needle valve begins to unseat, thereby limiting the amount of fuel being sprayed out during the initial stage of each fuel injection. Thus, each slug of fuel sprayed out may be regarded as consisting of two parts: initial throttled spray and terminating main spray.

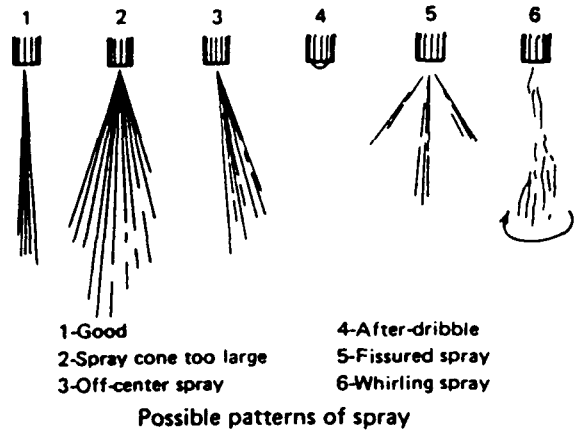

When tested on the nozzle tester, the injection nozzle can be made to produce these two kinds of spray for visual inspection. Initial throttled spray comes about when the tester lever is operated at a rate of 60 cycles per minute (up and down in one second); terminating main spray occurs when the lever is operated rapidly at a rate of, say, 4 to 6 cycles per second.

(a) Initial throttled spray

When the nozzle is producing only this spray, atomization is generally poor and the pattern is rather straight than conical, there being more or less after-dribble, that is, fuel dribbling after injection. All these are due to the fact that the fuel being injected is being throttled by the pintle protruding from the valve.

While the nozzle is making this spray, see if the needle valve chatters in synchronism with the cyclic motion of the lever; if so, then the needle valve is free from any sticking or hitching tendency and, if not, the nozzle and needle valve must be cleaned by washing and re-tested.

Off-center spray or directionally erratic spray, if noted, should be taken to mean that the injection nozzle needs thorough cleaning.

(b) Terminating main spray

With the tester lever operated at a rate of 4 to 6 cycles per second, the initial throttle spray is hardly visible. The spray under this condition may be regarded as main spray.

The main spray should be a good straight cone, consisting of finely atomized fuel particles without any large droplets, and should terminate with no dribble at the tip, not to mention of any fuel dripping.

(3) Seating tightness

An injection nozzle tested and adjusted as above, and found to produce a good spray pattern may be re-used in the engine provided that it passes this final test – seating tightness test.

With the injection nozzle mounted on the nozzle tester, raise the pressure slowly to 100 or 110 kg/cm^2 (1422 or 1564 psi) (without exceeding the set pressure of 120 kg/cm^2 (1706 psi), so that the needle valve will not unseat). Hold the pressure and observe the nozzle tip: there should be no evidence of fuel oozing out to form a dribble. If such evidence is noted, then the contacting faces of the needle valve and seat must be repaired by lapping in the manner already suggested or the injection nozzle as a whole must be replaced.

NOTE

Check injection nozzle for spray pattern every 1200 hours and remove carbon deposited around nozzle tip.

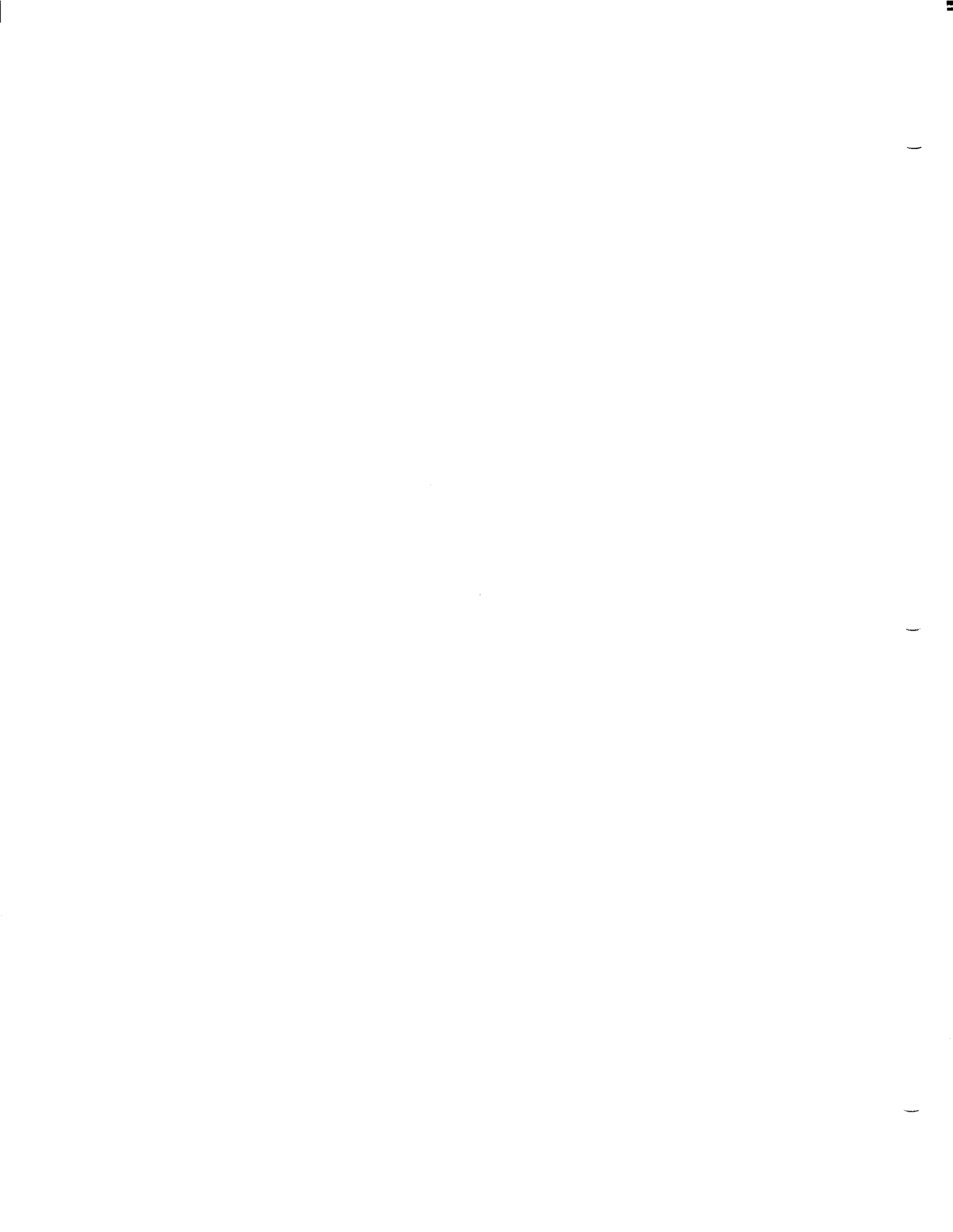



Hydraulic System

Table of Contents

SPECIFICATIONS	1	TEST NO. 2: Checking	
HYDRAULIC HOSE & FITTING INFORMATION	2	Counterbalance Oil Pressure	24
Hydraulic Hoses	2	TEST NO. 3: Checking Reel Circuit	
Hydraulic Fitting Installation	2	Working Pressure or Relief Pressure	24
SCHEMATICS	4	TEST NO. 4: Checking Reel	
General Pump Flow	4	Circuit Hydraulic Oil Supply	26
Steering Circuit	4	TEST NO. 5: Checking	
Lift/Lower Circuit	4	Reel Motor Efficiency	27
Traction Circuit	5	TEST NO. 6: Checking Steering Circuit	
Reel Circuit	5	Working Pressure or Relief Pressure	28
Engine Run - No Functions	6	TEST NO. 7: Checking Lift Circuit	
Steering Right	7	Working Pressure or Relief Pressure	29
Lift Circuit - Lift All Units	8	TEST NO. 8: Checking	
Lift Circuit - Lower All Units	9	Charge Pressure for Traction Circuit	30
Lift Circuit - Free Float (Detent)	10	EATON CHAR-LYNN STEERING CONTROL	
Traction Circuit - Forward	11	REPAIR INFORMATION	
Reel Circuit - All Units Mow (Free Float)	12	CESSNA COMPONENT SERVICE INSTRUCTIONS	
Reel Circuit - Units 1, 2 & 3 Mow (Free Float) ...	13	Reel Motor	
Lift Circuit - Units 1, 2, 3 & 5 Mow (Free Float) ..	14	Steering Pump	
Reel Circuit - Any Unit Backlap	15	Lift Control Valve	
TROUBLESHOOTING	16	Priority Flow Divider	
Slow or No Traction In Either Direction	17	Lift Cylinder	
Reels Slow or Won't Turn	18	Reel Control Valve	
Steering Loss	19	Reel Shut Off Valve	
Cutting Units Lift Slow or Won't Lift	20	Traction Pump	
Cutting Units Won't Drop		Traction Motor	
or Follow Ground Contours	21	VICKERS GEAR PUMP SERVICE MANUAL	
TESTING	22	AUBURN GEAR POWER WHEEL	
TEST NO. 1: Checking Traction		PLANETARY GEAR DRIVE SERVICE MANUAL	
Circuit Working Pressure or Relief Pressure	23		

Specifications

Hydraulic System: Reservoir capacity is 15 gal. (58 L) and total system capacity is 18.2 gal. (69 L). Replaceable breather element. Replaceable spin-on filter element.

Hydraulic Oil: Mobil DTE 26 / Shell Tellus 68 or equivalent*

* Equivalent Hydraulic Oils (interchangeable):

- Amoco Rykon Oil #68
- Conoco Super Hydarulic Oil 68
- Exxon Nuto H 68
- Kendall Kenoil R & O AW 68
- Pennzoil Penreco 68
- Phillips Magnus A 68
- Standard Energol HLP 68
- Sun Sunvis 831 WR
- Union Unax AW 68

Hydraulic Hose and Fitting Information

Hydraulic Hoses

Hydraulic hoses are subject to extreme conditions such as, pressure differentials during operation and exposure to weather, sun, chemicals, very warm storage conditions or mishandling during operation or maintenance. These conditions can cause damage or premature deterioration. Some hoses, such as deck motor hoses, are more susceptible to these conditions than others. Inspect the hoses frequently for signs of deterioration or damage.

When replacing a hydraulic hose, be sure that the hose is straight (not twisted) before tightening the fittings. This can be done by observing the imprint on the hose. Use two wrenches; one to hold the hose straight and one to tighten the hose swivel nut onto the fitting.



WARNING

Before disconnecting or performing any work on the hydraulic system, all pressure in the system must be relieved by lowering the front deck to the ground, raising or lowering the wing decks completely, and stopping the engine.

Keep body and hands away from pin hole leaks or nozzles that eject hydraulic fluid under high pressure. Use paper or cardboard, not hands, to search for leaks. Hydraulic fluid escaping under pressure can have sufficient force to penetrate the skin and do serious damage. If fluid is injected into the skin, it must be surgically removed within a few hours by a doctor familiar with this type of injury or gangrene may result.

Hydraulic Fitting Installation

O-Ring Face Seal

1. Make sure both threads and sealing surfaces are free of burrs, nicks, scratches, or any foreign material.
2. Make sure the O-ring is installed and properly seated in the groove. It is recommended that the O-ring be replaced any time the connection is opened.
3. Lubricate the O-ring with a light coating of oil.
4. Put the tube and nut squarely into position on the face seal end of the fitting and tighten the nut until finger tight.
5. Mark the nut and fitting body. Hold the body with a wrench. Use another wrench to tighten the nut to the correct flats from finger tight (F.F.F.T.). The markings on the nut and fitting body will verify that the connection has been tightened.

Size	F.F.F.T.
4 (1/4 in. nominal hose or tubing)	.75 ± .25
6 (3/8 in.)	.75 ± .25
8 (1/2 in.)	.75 ± .25
10 (5/8 in.)	1.00 ± .25
12 (3/4 in.)	.75 ± .25
16 (1 in.)	.75 ± .25

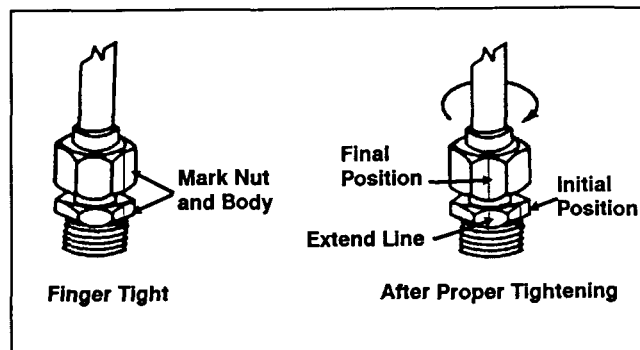
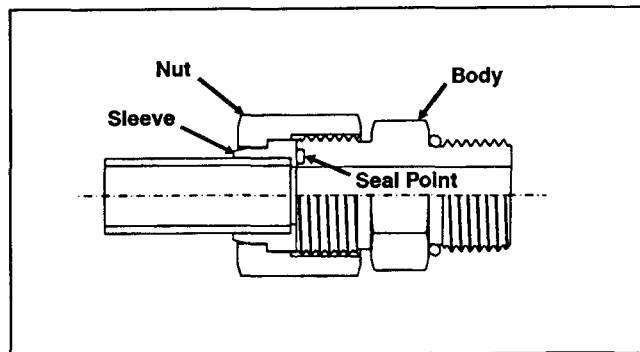

SAE Straight Thread O-Ring Port (Non-adjustable)

1. Make sure both threads and sealing surfaces are free of burrs, nicks, scratches, or any foreign material.
2. Always replace the O-ring seal when this type of fitting shows signs of leakage.
3. Lubricate the O-ring with a light coating of oil.
4. Install the fitting into the port and tighten it down full length until finger tight.
5. Tighten the fitting to the correct flats from finger tight (F.F.F.T.).

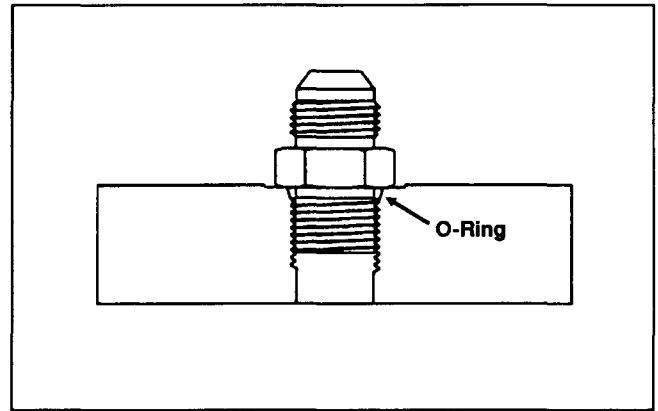

Size	F.F.F.T.
4 (1/4 in. nominal hose or tubing)	1.00 ± .25
6 (3/8 in.)	1.50 ± .25
8 (1/2 in.)	1.50 ± .25
10 (5/8 in.)	1.50 ± .25
12 (3/4 in.)	1.50 ± .25
16 (1 in.)	1.50 ± .25

SAE Straight Thread O-Ring Port (Adjustable)

1. Make sure both threads and sealing surfaces are free of burrs, nicks, scratches, or any foreign material.
2. Always replace the O-ring seal when this type of fitting shows signs of leakage.
3. Lubricate the O-ring with a light coating of oil.
4. Turn back the jam nut as far as possible. Make sure the back up washer is not loose and is pushed up as far as possible (Step 1).
5. Install the fitting into the port and tighten finger tight until the washer contacts the face of the port (Step 2).
6. To put the fitting in the desired position, unscrew it by the required amount, but no more than one full turn (Step 3).
7. Hold the fitting in the desired position with a wrench and turn the jam nut with another wrench to the correct flats from finger tight (F.F.F.T.) (Step 4).

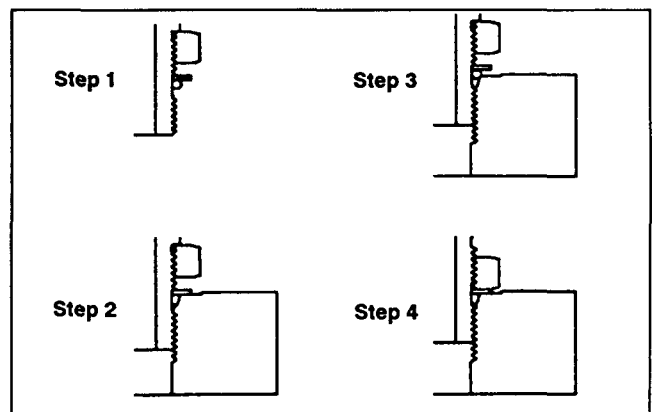
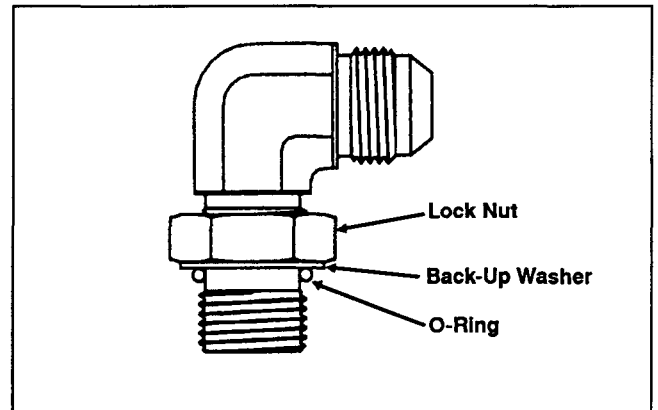

Size	F.F.F.T.
4 (1/4 in. nominal hose or tubing)	1.00 ± .25
6 (3/8 in.)	1.50 ± .25
8 (1/2 in.)	1.50 ± .25
10 (5/8 in.)	1.50 ± .25
12 (3/4 in.)	1.50 ± .25
16 (1 in.)	1.50 ± .25

Schematics

General Pump Flow

Refer to "Engine Run - No Functions" Schematics

The traction, reel, and auxiliary pumps are directly coupled to the engine. With all controls in neutral and the engine running, the steer-lift pump draws oil through the suction line from the reservoir. Priority output flow is directed to the steering function. Excess flow exits the secondary output of the pump and is directed to the lift valve.

The flow continues through the lift valve where it meets the counter-balance valve. The counterbalance valve "super-charges" the incoming oil before allowing the oil to continue on its' return path back to the sump tank. The counterbalance pressure may be monitored at pressure tap port 3.

The oil pressure provided by the counterbalance valve will be used to reduce the cutting unit weight on the turf during the mowing function.

After joining with oil returning from other functions through the drain block, the oil flows through the oil cooler to dissipate heat from the hydraulic system and then through the filter to collect any particles in the hydraulic system.

Clean oil is collected at the filter by the charge pump. This oil is used to maintain a supply of oil to the closed-loop traction circuit to prevent cavitation. The charge pressure is regulated by a relief internal to the traction pump. The charge pressure may be monitored at the pressure tap port on top of the charge pump.

Oil collected by the reel pump is directed to the reel speed valve and split into two variable flows. Primary oil is directed to the reel "On-Off" control valve. With the valve in the "Off" position, the oil is returned directly to the drain block. The remaining oil will also return to the tank through the drain block.

Steering Circuit

Refer to "Steering Right" Schematic

With the engine running, the priority flow of oil from the steer-lift pump is directed to the power steering unit at the base of the steering column and returns to the reservoir.

Turning the steering wheel to the right moves the control spool in the steering unit to direct the oil to the steer-

ing cylinder for a right-hand turn. Turning the steering wheel to the left has the opposite effect. Cylinder movement returns oil from the low pressure side back through the power steering unit to the reservoir.

System pressure may be monitored at pressure tap port 5.

Lift/Lower Circuit

Refer to "Lift Circuit" Schematics

The lift cylinders are controlled by an open center valve with three spools. The number 4 and 5 cutting units are independently controlled. The center spool controls the number 1, 2, and 3 cutting units.

To lift the cutting units, the engine must be running above half throttle. The flow of oil from the steer and lift pump is used to accomplish the lift function. Holding a lever in the LIFT position will direct the flow of oil to the lift cylinder and raise the cutting unit. Oil pressure to the lift cylinder is monitored during LIFT by a relief at the valve inlet. System pressure may be monitored at the pressure tap port on the lift valve.

Moving the lever forward will open a path for oil to escape from the lift cylinder. The weight of the cutting unit will push oil from the cylinders through the valve allow-

ing the cutting unit to lower. Moving the lever into "LIFT" while the cutting unit is lowering will lock the cutting unit at any position by trapping oil between the valve and cylinder.

The cylinders work against counterbalance pressure during lowering. For this reason, the cutting units will drop faster at slow engine speeds or low counterbalance pressures compared to full engine speed or high counterbalance pressures. The counterbalance pressure may be monitored at pressure tap port 3.

Since the lift levers are spring loaded for return to neutral, a detent plunger latches the spool in the valve to hold the spool in a "Free Float" position. This position enables the cutting units to follow ground contours by allowing a two-way flow between the lift valve and lift cylinders.

Traction Circuit

Refer to "Traction Circuit - Forward" Schematics

A mechanical interlock between the traction pedal linkage and the parking brake prevents traction pedal movement unless the brake is released.

Depressing the top of the traction pedal will shift the traction pump swash plate to direct a flow of oil to the forward inlet of the traction motors. The oil returns from the motor to the pump where it continues through the pump

in a closed-loop circuit. System pressure may be monitored at pressure tap port 1.

Depressing the bottom of the traction pedal causes the oil to flow in the reverse direction. System pressure for the reverse function may be monitored at pressure tap port 2.

Reel Circuit

Refer to "Reel Circuit" Schematics

The three reel shut-off valves in this circuit enable the cutting units to be operated in several configurations for easier control, better clearance or closer trimming.

The reel pump supplies a constant flow of oil to the reel speed control valve. The reel speed is variable and adjustable by the operator to supply a flow of oil to the reel "On-Off" valve. Oil not needed to obtain the selected reel speed is directed back to the sump tank through the drain block, oil cooler, and filter.

When the reel "On-Off" valve lever is moved into "Mow" to engage the reels, a spool in the valve is shifted to direct oil to the shut-off valve at the front of the unit. With the Number 1, 2, and 3 cutting units in mowing position, the shut-off valve will allow oil to flow to the Number 2, the Number 3, and the Number 1 reel motor. The oil is also available for use at the Number 4 shut-off valve. If the Number 1, 2, and 3 cutting units are in the raised position, the oil will bypass these motors and be available directly to the Number 4 shut-off valve.

With the Number 4 cutting unit in the down and mowing position, the Number 4 shut-off valve will allow the oil through to drive the reel motor and then to the Number 5 shut-off valve. If the Number 4 cutting unit is in the

raised position, the oil will bypass the Number 4 reel motor and be available directly to the Number 5 shut-off valve.

With the Number 5 cutting unit in the down and mowing position, the Number 5 shut-off valve will allow the oil through to drive the reel motor. If the Number 5 cutting unit is in the raised position, the oil will bypass the Number 5 reel motor and return to the reel "On-Off" valve. From the reel "On-Off" valve, the oil returns to the sump tank through the drain block, oil cooler, and filter.

"Backlap" is provided by pulling the reel "On-Off" valve lever up and back. The backlap function requires that the lever be held in this position for safety. The direction of flow in "Backlap" is the opposite of "Mow." Some units will include a lo-speed backlap valve in the circuit to remove some oil flow from the circuit during the backlap function. The reduced oil flow results in a slower reel speed in "Backlap," but does not affect performance during "Mow."

System pressure may be monitored at pressure tap 4 for either "Mow" or "Backlap."

Engine Run - No Functions

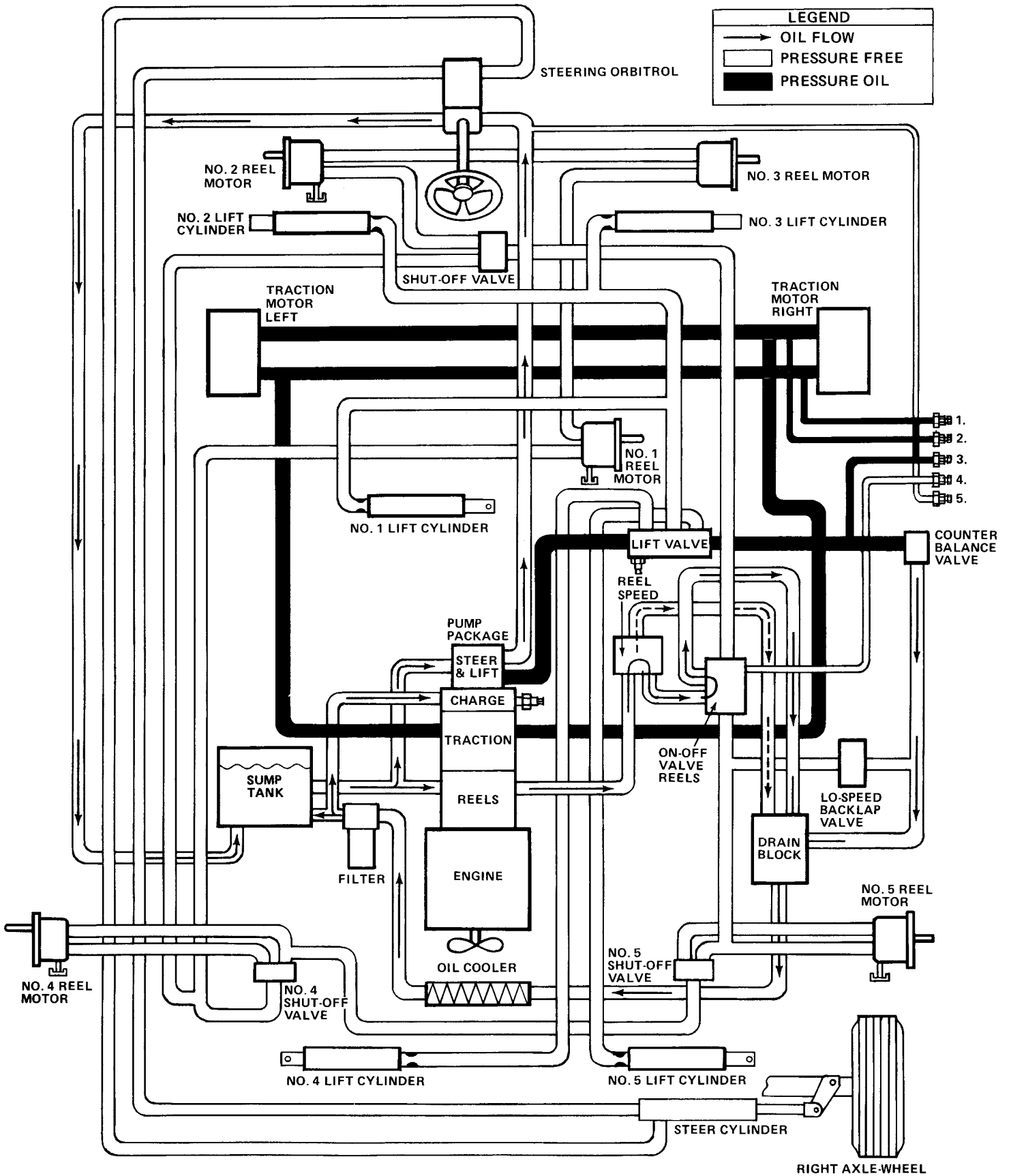

Steering Right

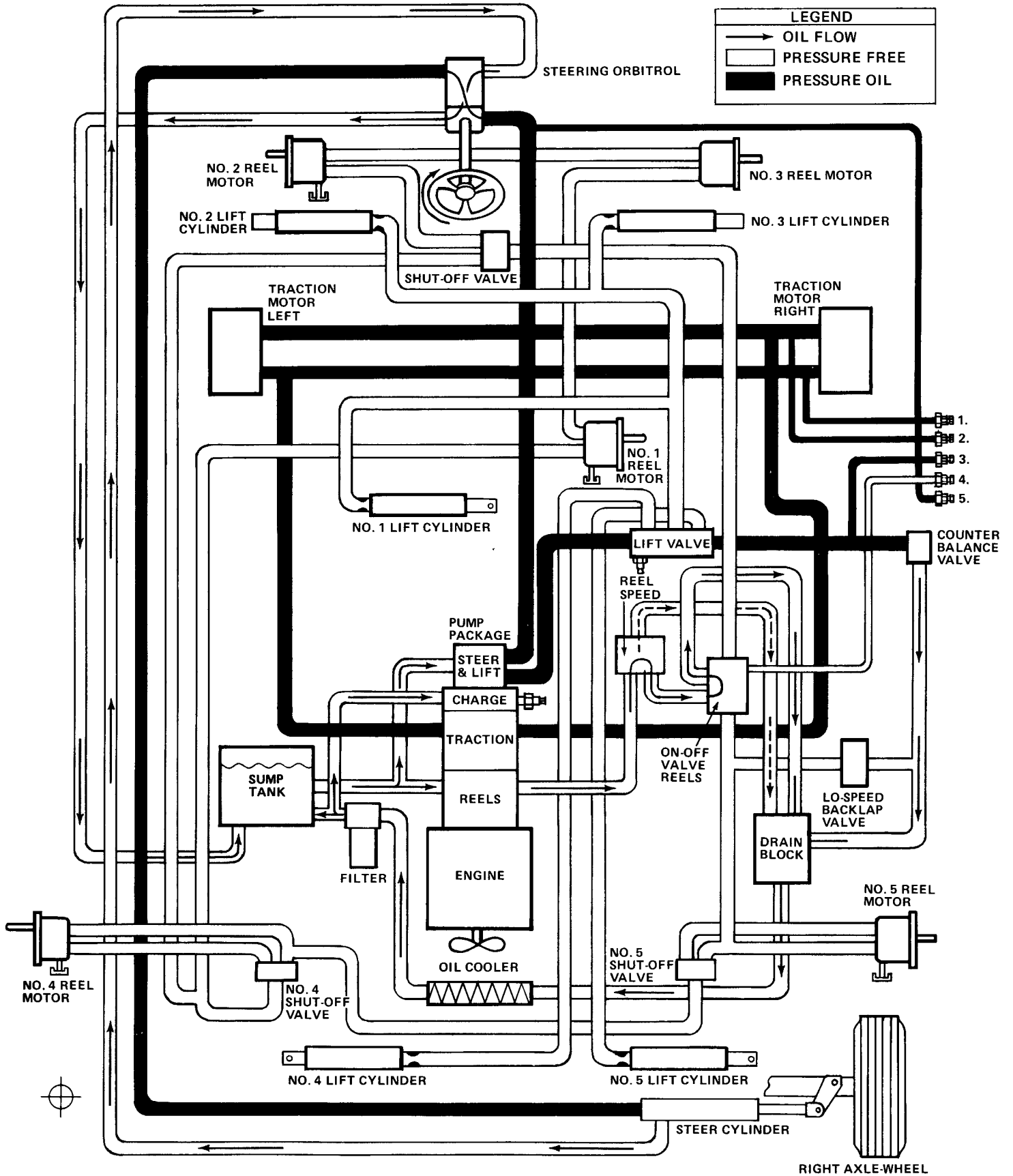

Lift Circuit - Lift All Units

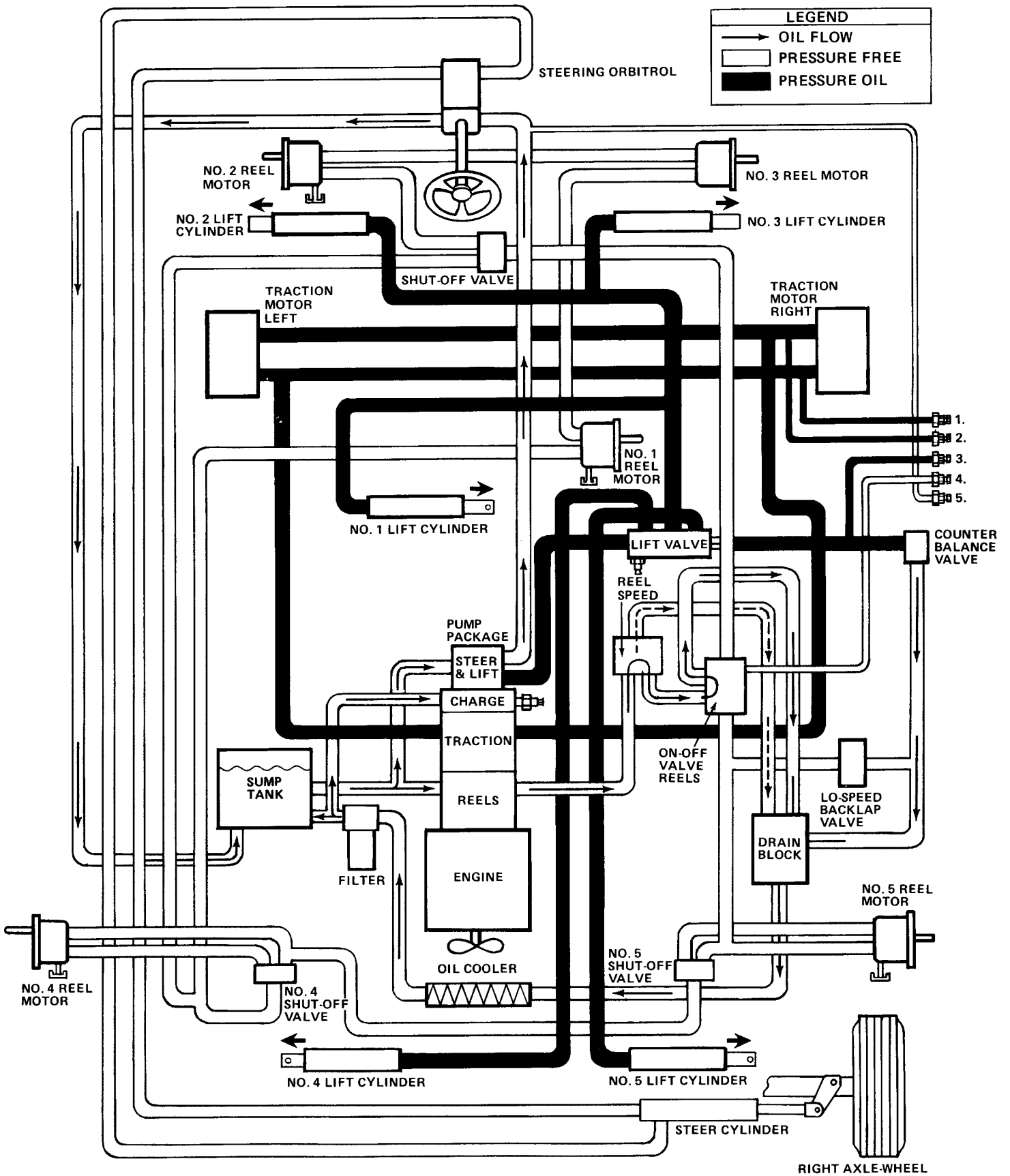

Lift Circuit – Lower All Units

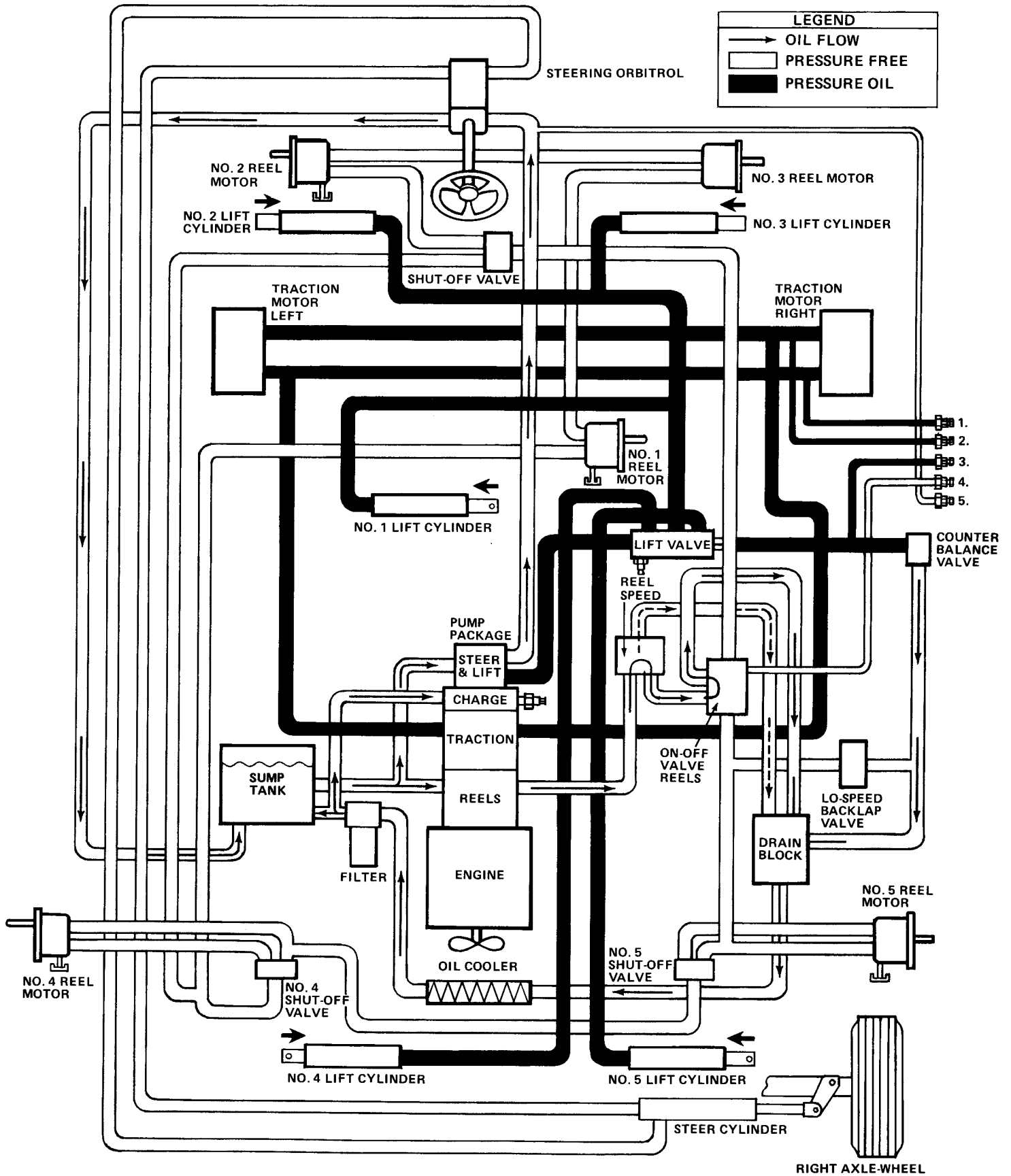

Lift Circuits - Free Float (Detent)

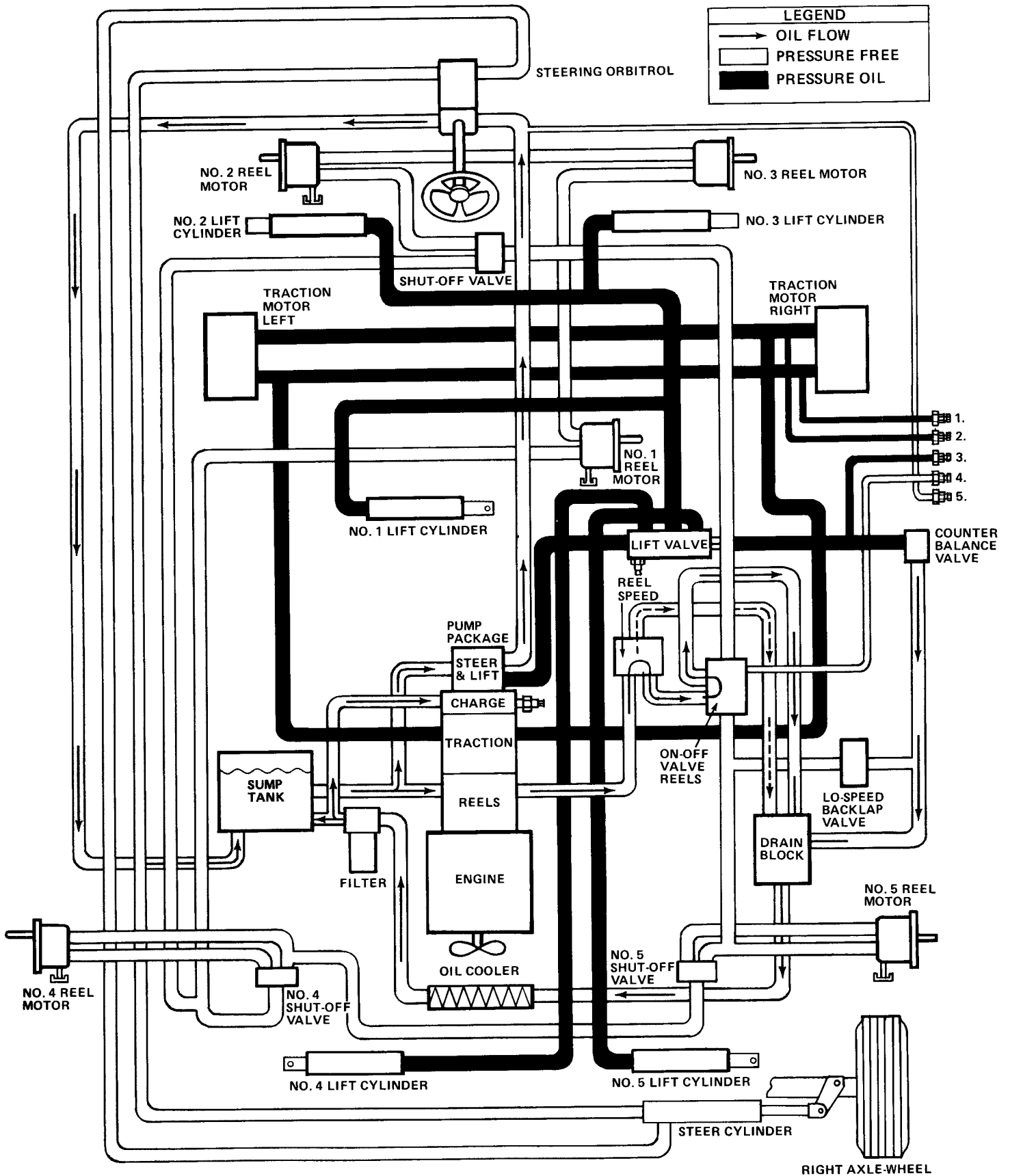

Traction Circuit – Forward

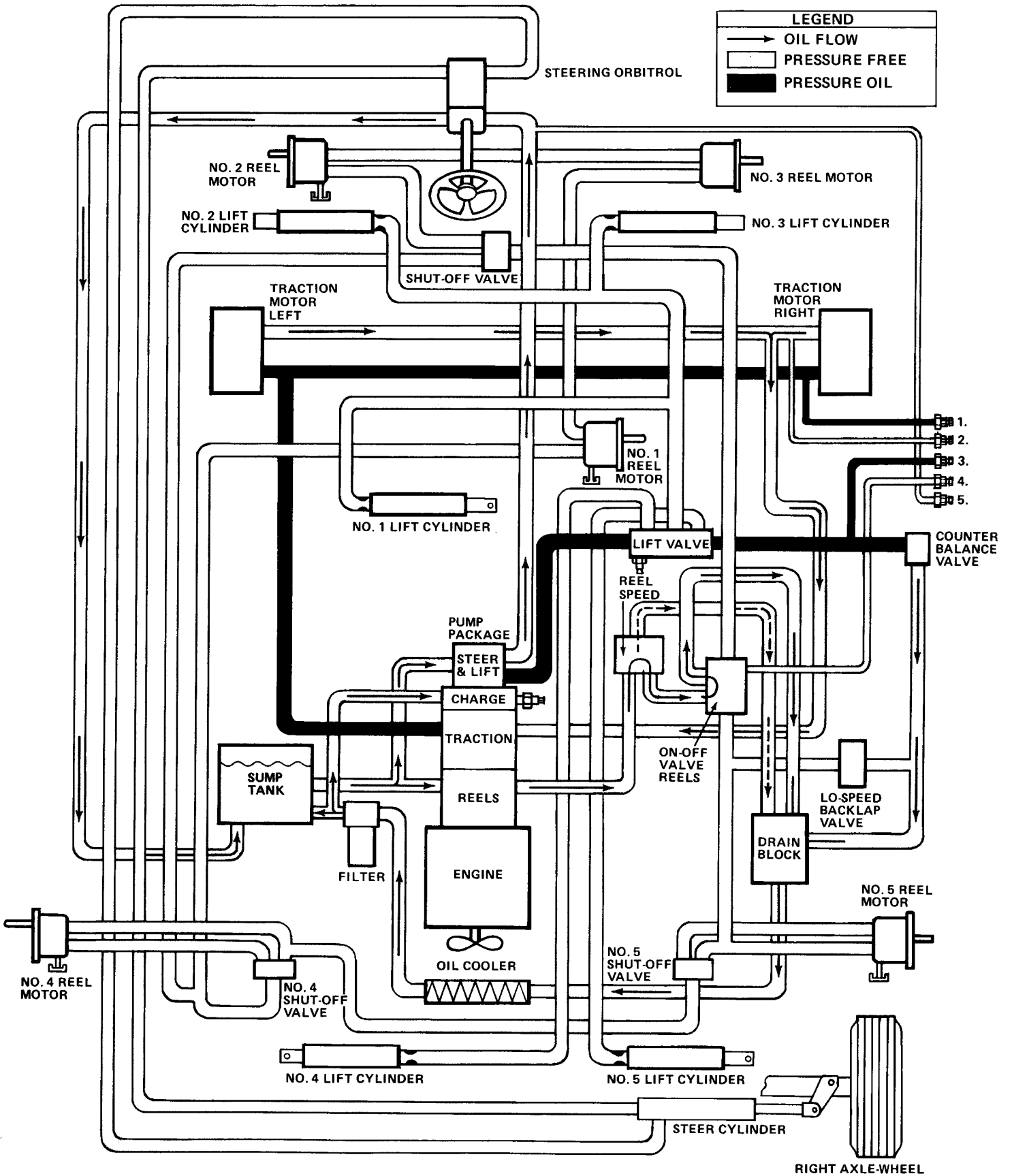

Reel Circuit - All Units Mow (Free Float)

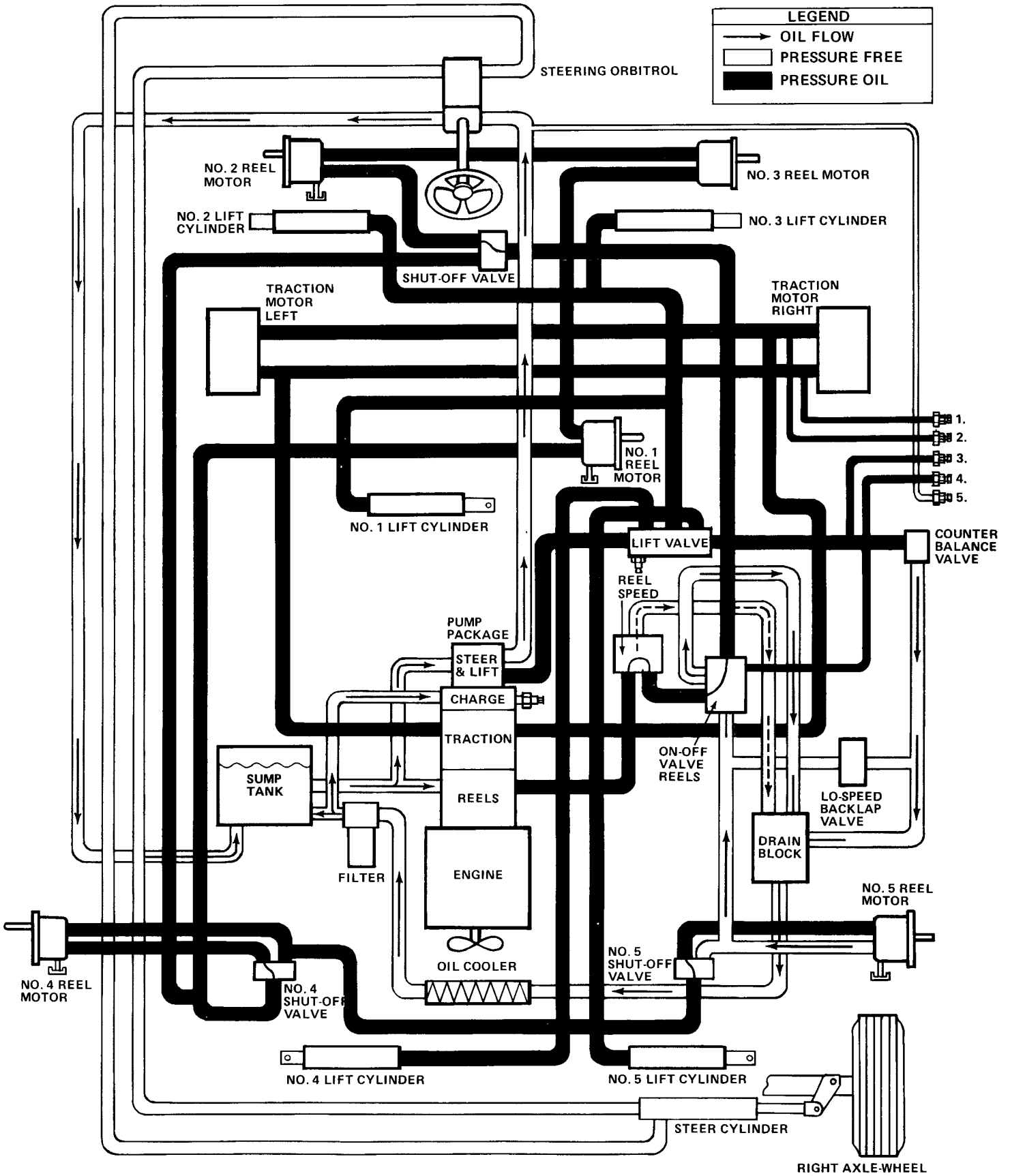

Reel Circuit - Units 1, 2 & 3 Mow (Free Float)

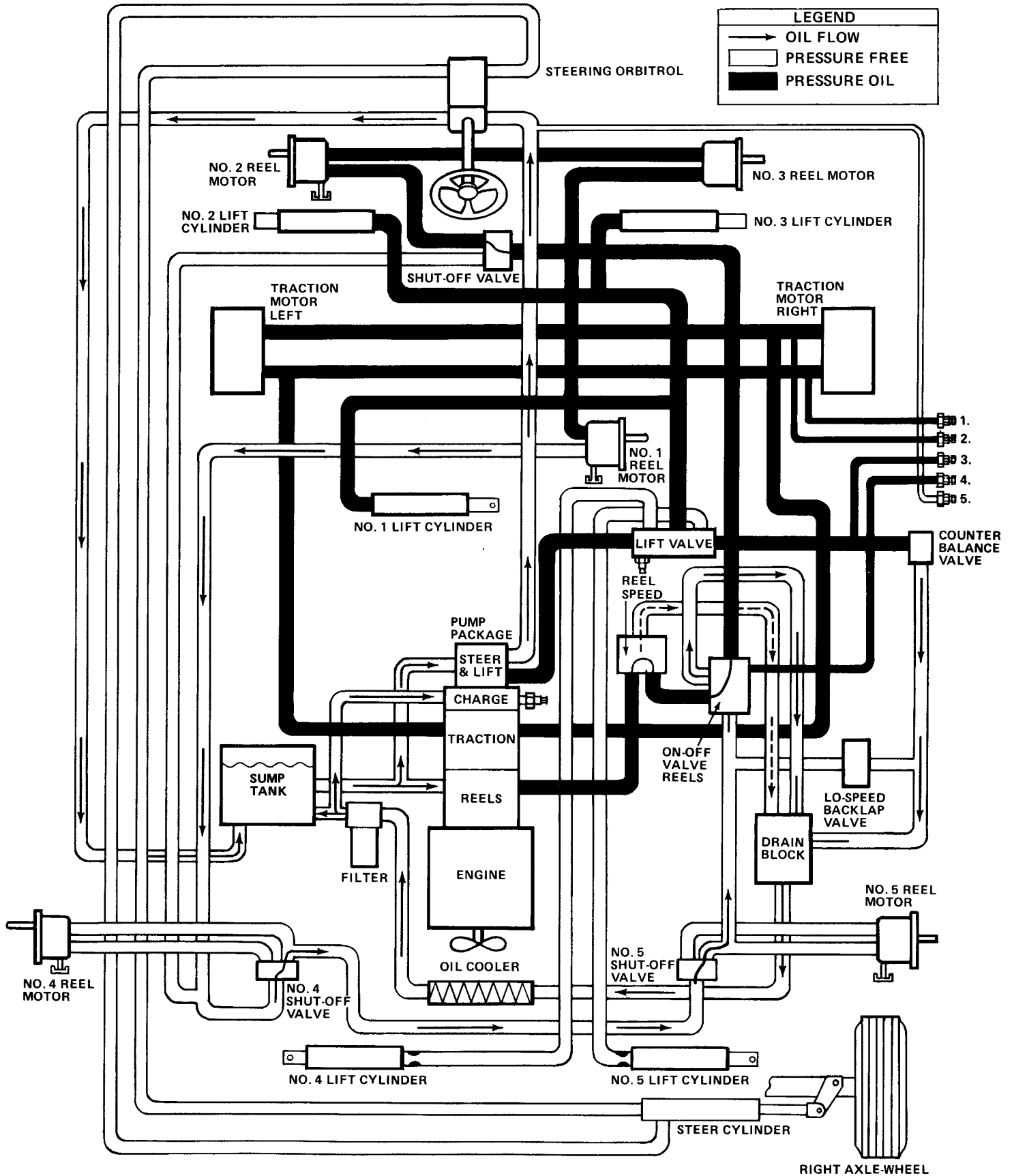

Lift Circuit – Units 1, 2, 3 & 5 Mow (Free Float)

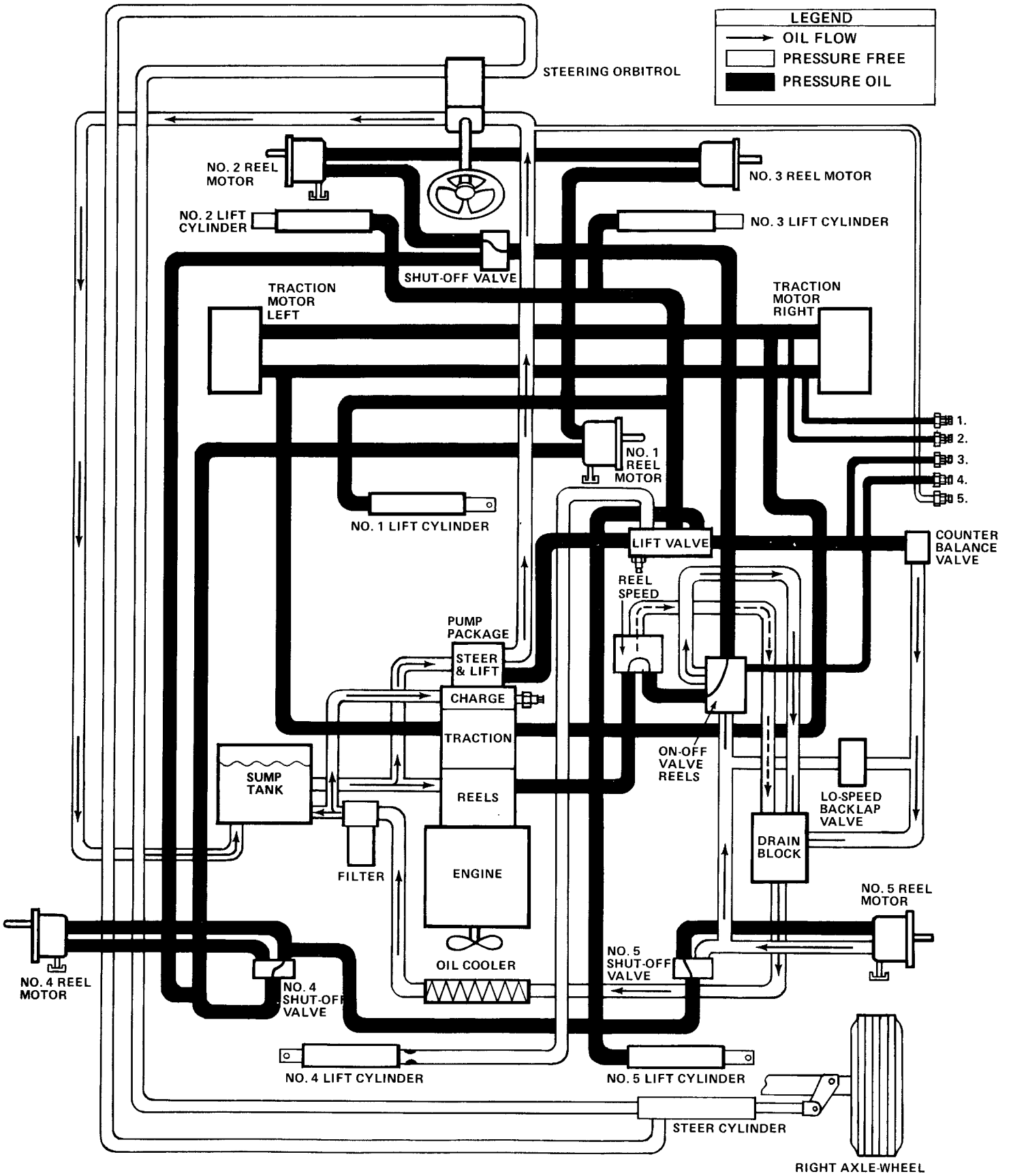

Reel Circuit - Any Unit Backlap

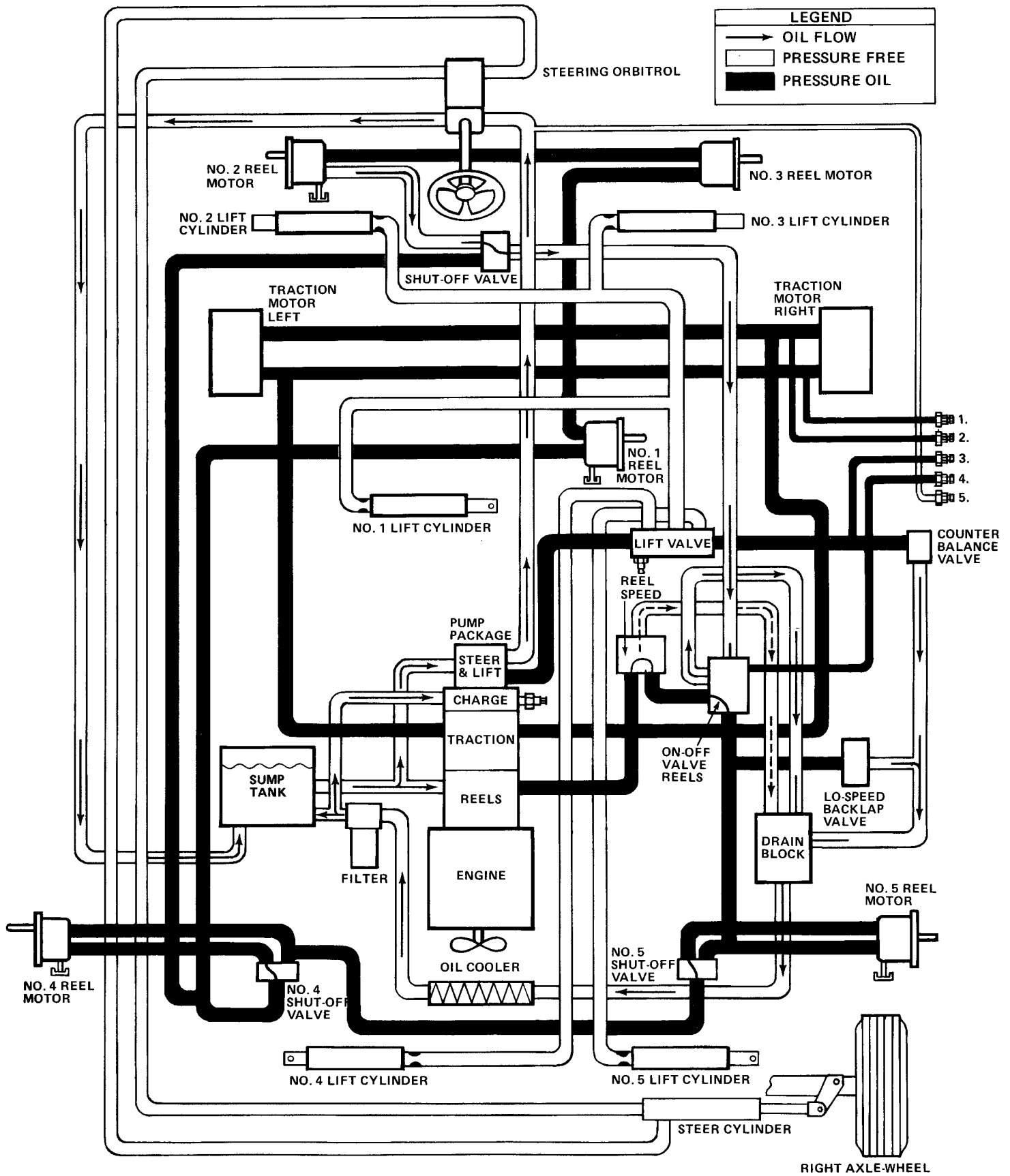

Troubleshooting

The cause of an improperly functioning hydraulic system is best diagnosed with the use of proper testing equipment and a thorough understanding of the complete hydraulic system.

A hydraulic system with an excessive increase in heat or noise is a potential failure. Should either of these conditions be noticed, immediately stop the machine, turn off the engine, locate the cause of the trouble, and correct it before allowing the machine to be used again. Continued use of an improperly functioning hydraulic system could lead to extensive internal component damage.

The charts that follow contain detailed information to assist in troubleshooting. There may possibly be more than one cause for a machine malfunction. All causes should be checked in the order in which they are listed on the charts; do not deviate from this procedure.

Refer to **Testing** in this section for precautions and specific test procedures.

Slow or No Traction in Either Direction

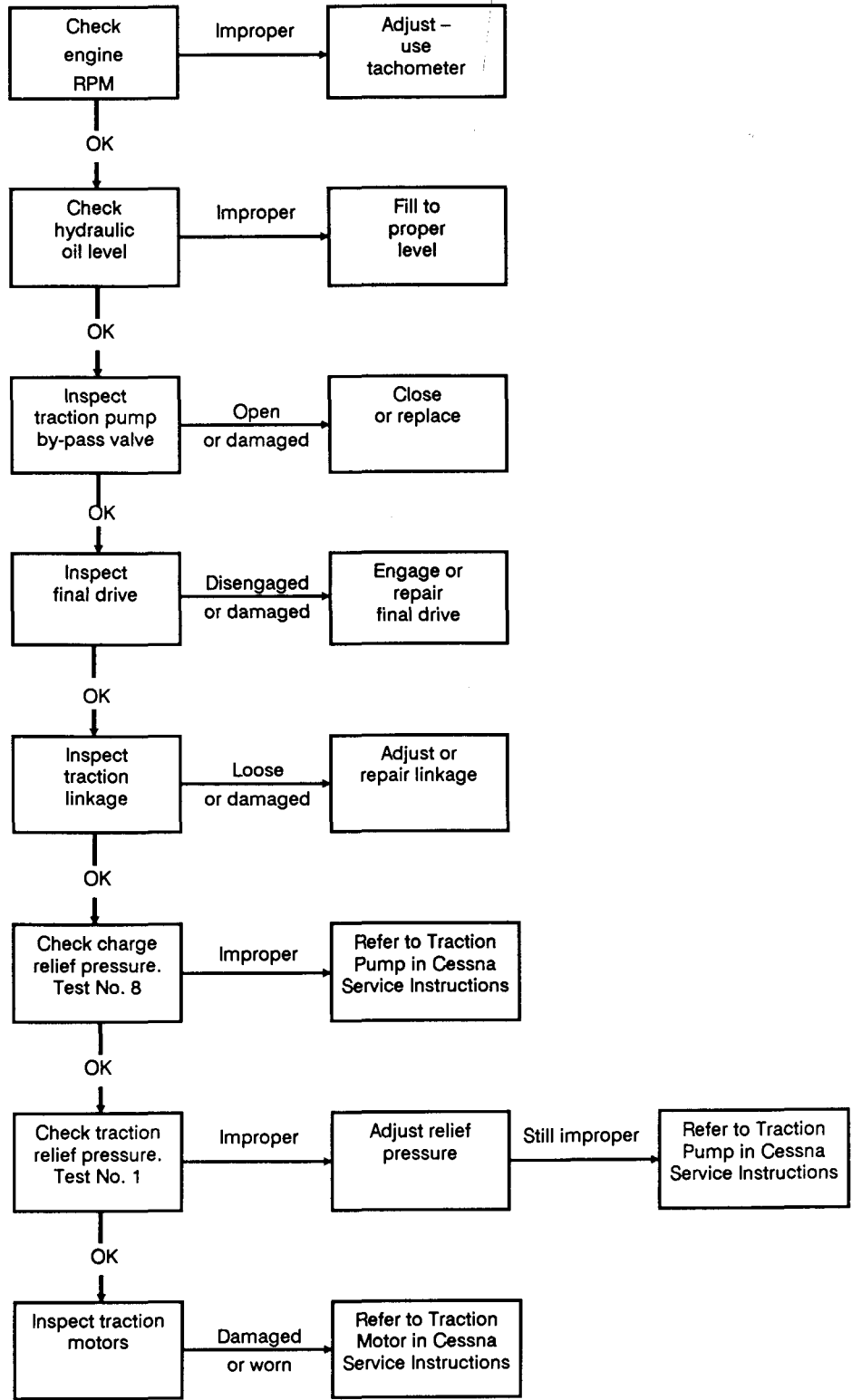

Reels Slow or Won't Turn

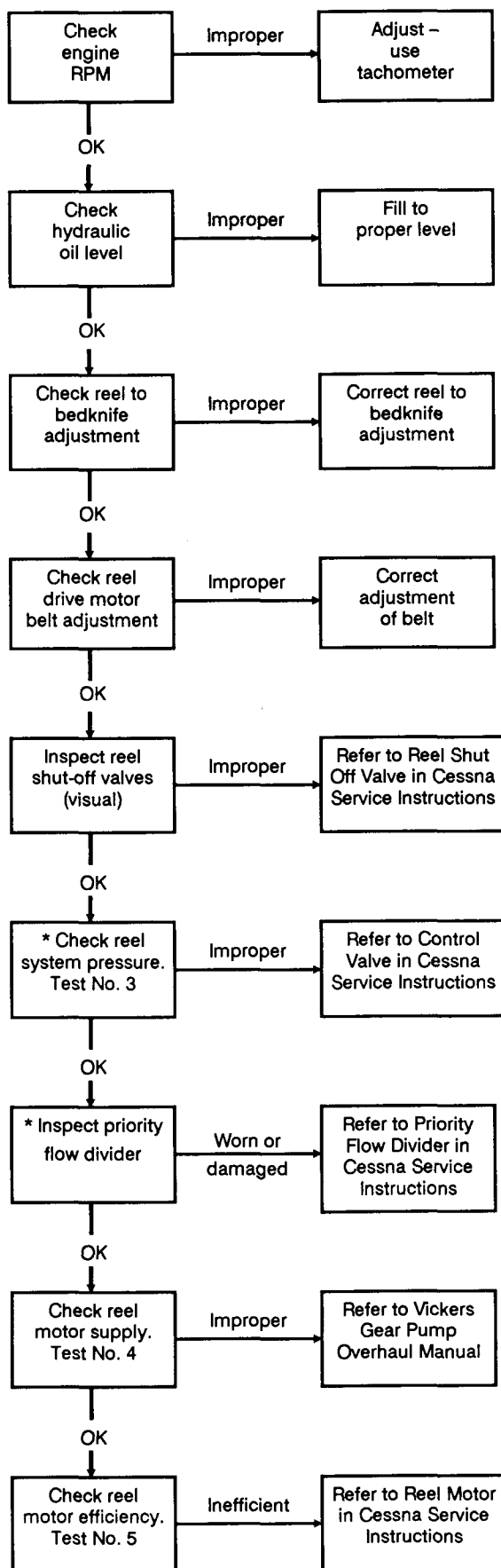

* All units will be slow or won't turn.

Steering Loss

NOTE: Steering loss after washing is referred to as "THERMAL SHOCK". Normal functions will return after orbital temperatures stabilize (approximately 15 minutes). DO NOT ATTEMPT TO TURN STEERING WHEEL UNTIL TEMPERATURES STABILIZE WHEN THERMAL SHOCK IS NOTED.

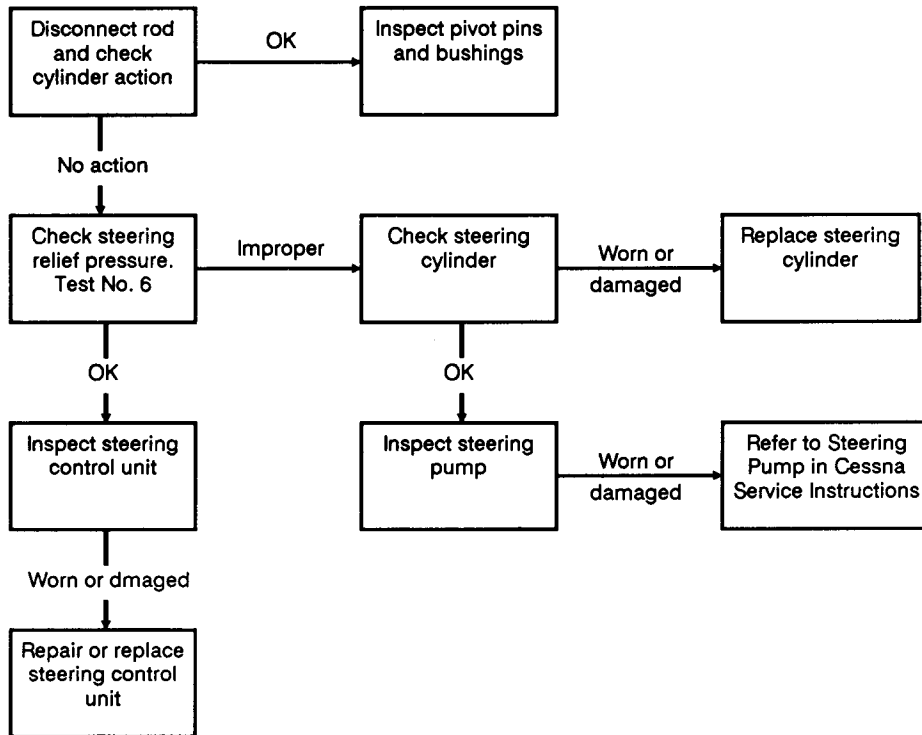

Cutting Units Lift Slow or Won't Lift

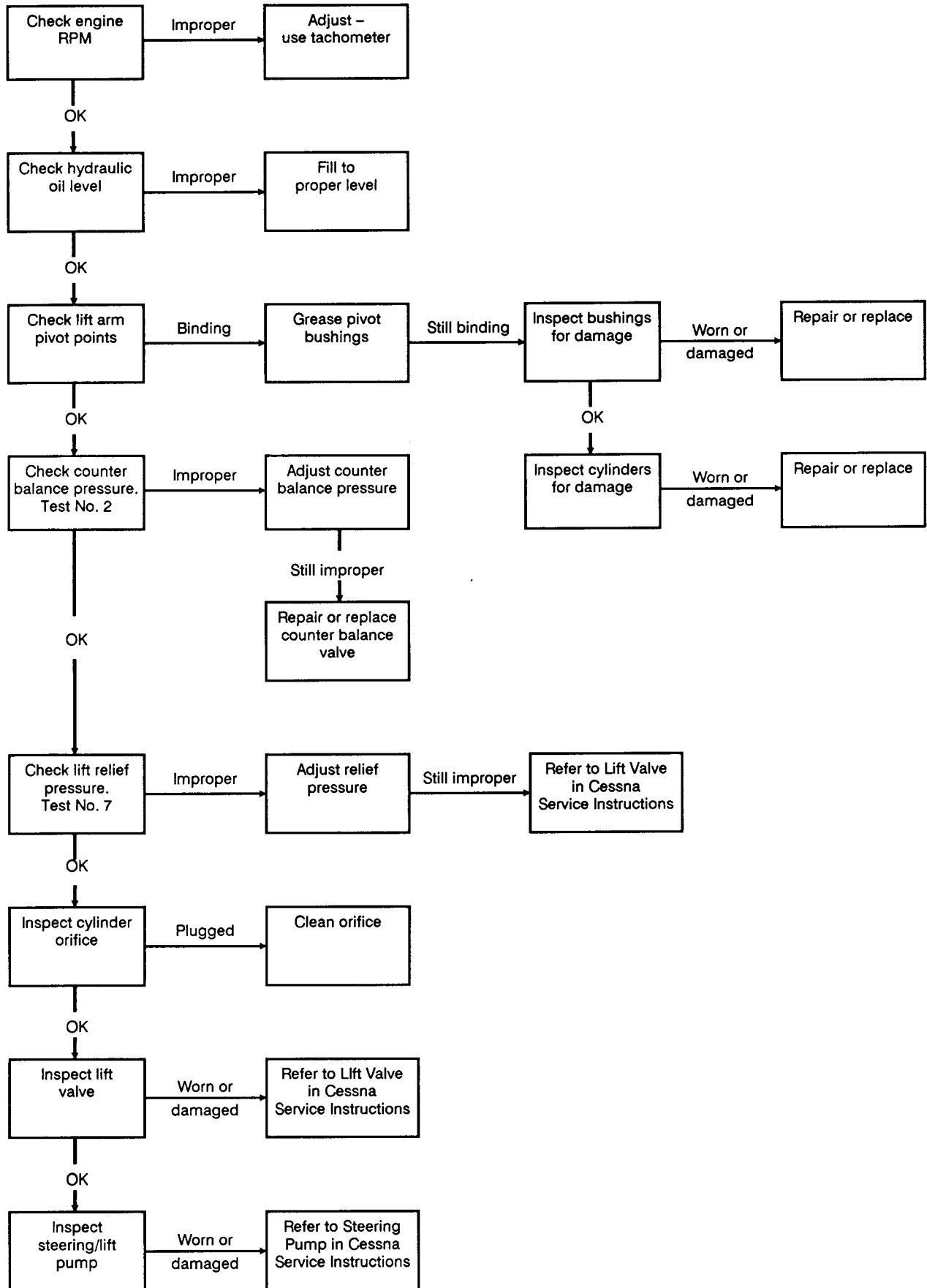

Cutting Units Won't Drop or Follow Ground Contours

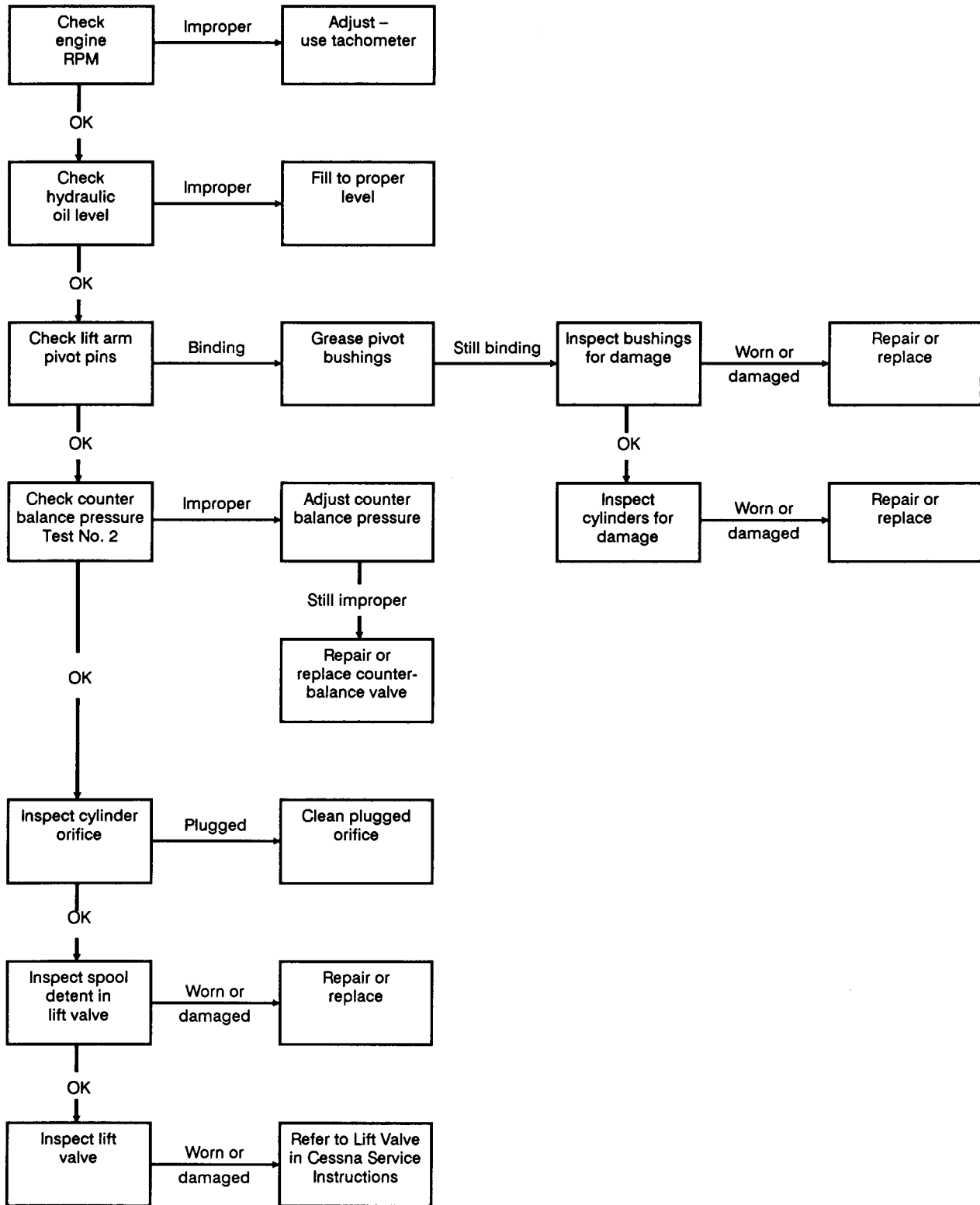

Testing

The most effective method for isolating problems in the hydraulic system is by using hydraulic test equipment such as pressure gauges and flow meters in the circuits during various operational checks.



WARNING

Failure to use gauges with the recommended pressure (psi) rating as listed in the test procedures could result in damage to the gauge and possible personal injury from leaking hot oil.

NOTE: Special tools, such as hydraulic test equipment, can be ordered from the *TORO SPECIAL TOOLS AND APPLICATIONS GUIDE (COMMERCIAL PRODUCTS)*.

Before Performing Hydraulic Tests

All obvious areas such as oil supply, filter, binding linkage, loose fasteners, or improper adjustments must be checked before assuming that a hydraulic component is the source of the problem being experienced.



WARNING

Before disconnecting or performing any work on the hydraulic system, all pressure in the system must be relieved by lowering the cutting units to the ground, or by raising and locking the cutting units, and shutting the engine OFF.

Keep body and hands away from pin hole leaks or nozzles that eject hydraulic fluid under high pressure. Use paper or cardboard, not hands, to search for leaks. Hydraulic fluid escaping under pressure can have sufficient force to penetrate skin and do serious damage. If fluid is injected into the skin, it must be surgically removed within a few hours by a doctor familiar with this type of injury or gangrene may result.

1. Thoroughly clean the machine before disconnecting or disassembling any hydraulic components. Always keep in mind the need for cleanliness when working on hydraulic equipment.

2. Put caps or plugs on any hydraulic lines left open or exposed during testing or removal of components.

3. The engine must be in good operating condition. ALWAYS use a tachometer when making a hydraulic test. Engine speed will affect the accuracy of the tester readings.

4. To prevent damage to tester or components, the inlet and the outlet hoses must be properly connected, and not reversed (tester with pressure and flow capabilities).

5. To minimize the possibility of damaging components, completely open the load valve by turning it counterclockwise (tester with pressure and flow capabilities).

6. Install fittings finger tight, far enough to insure that they are not cross-threaded, before tightening with a wrench.

7. Position the tester hoses so that rotating machine parts will not make contact with them and result in hose or tester damage.

8. Check the oil level in the reservoir.

9. Check the control linkage for improper adjustment, binding or broken parts.

10. All hydraulic tests should be made with the hydraulic oil at normal operating temperature (hoses warm to the touch).

TEST NO. 1: Checking Traction Circuit Working Pressure Or Relief Pressure

Procedure For Working Pressure Check:

1. Install a 10,000 psi gauge into the traction circuit quick disconnect for the function to be checked.
2. Operate the unit while monitoring gauge.

RANGE OF TESTER READINGS: 50 - 5300 psi

3. If working pressure is too low, perform the traction circuit relief pressure check.

Procedures for Relief Pressure Check: Unit must be moved to open area.

1. Hydraulic oil must be at operating temperature.
2. Install a 10,000 psi gauge into the traction circuit quick disconnect for the function to be checked.
3. Set traction pedal stop for minimum ground speed (1 mph).
4. Start the engine and move throttle to full speed (2500 rpm).
5. Release Parking Brake.
6. Engage the traction pedal to set unit in motion.
7. Maintain traction pedal engagement while momentarily engaging the parking brake to bring the unit to a halt and read gauge.

TESTER READING TO BE APPROXIMATELY 5300 psi.

8. If traction pressure is too low, inspect the traction pump check valves and relief valves. Clean or replace relief valve(s) or check valves as necessary. If check valves and relief valves are in good condition, replace or overhaul the traction pump.

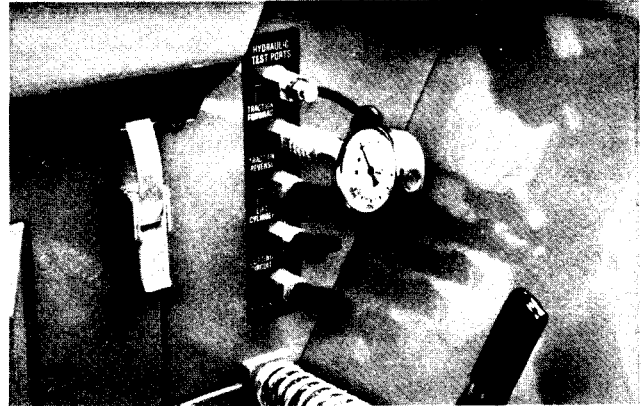

TEST NO. 2: Checking Counterbalance Oil Pressure

Procedure:

1. Install a 1000 psi gauge into the center quick disconnect as shown.
2. Start the engine and move throttle to full speed (2500 rpm)

TESTER READING SHOULD BE WITHIN THE RANGE LISTED:

COLD OIL: 600 - 650 psi

HOT OIL: 500 - 550 psi

NOTE: Due to special conditions or customer preference, the counterbalance may require setting outside this recommended range. However, the range listed will be adequate for most conditions.

3. If necessary, adjust the relief valve screw until the desired pressure is attained. Adjust nearer the high end of the range for improved hill climbing or nearer the low end for improved quality-of-cut.

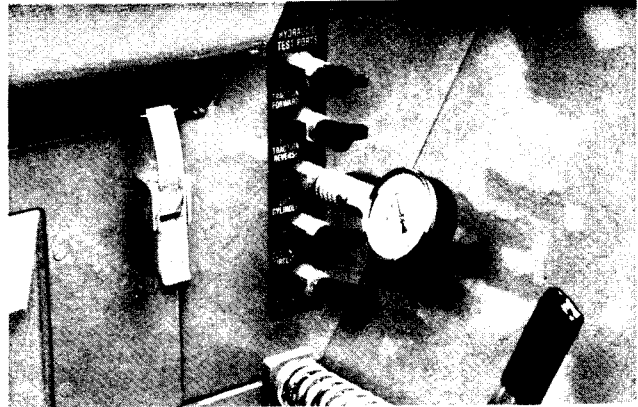

TEST NO. 3: Checking Reel Circuit Working Pressure Or Relief Pressure

Procedure For Working Pressure Check:

1. Install a 5000 psi gauge onto the cutting circuit quick disconnect.
2. Operate the unit while monitoring the gauge.

RANGE OF TESTER READINGS 0 - 3000 psi.

3. If working pressure is too high or too low, perform relief pressure check.

NOTE: Normal pressure during operation is 1500 - 2000 psi. However the gauge may spike higher during initial engagement of the control lever.

Procedures For Relief Pressure Check:

1. Hydraulic oil must be at operating temperature.
2. Install a 5000 psi gauge onto the cutting circuit quick disconnect.
3. Start the engine and lower the No. 2 and 3 cutting units to the ground.
4. Turn the engine OFF.
5. Block the reel of the No. 2 cutting unit to prevent rotation. The No. 2 cutting unit motor is the first in series flow from the pump. Use a substantial hardwood block inserted between the reel blades.



CAUTION

Stand clear of the reels during the following procedures.

6. Place reel speed control knob at minimum.
7. Start engine and position throttle at idle.
8. Ease the reel control lever into "MOW" while monitoring the gauge.

NOTE: It may be necessary to raise the throttle slightly to prevent the engine from stalling.

TESTER READING TO BE 2700 - 3000 psi.

9. If reel circuit relief pressure is above 3000 PSI or below 2700 PSI, clean or replace relief valve in reel control valve.

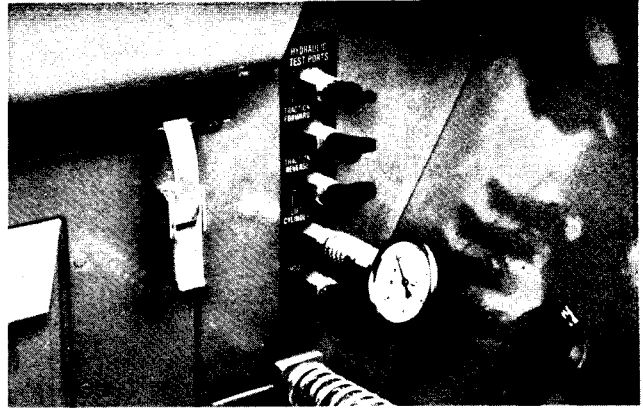

TEST NO. 4: Checking Reel Circuit Hydraulic Oil Supply

Procedure:

1. Hydraulic oil must be at operating temperature.
2. Start the engine and lower the No. 2 and 3 cutting units to the ground.
3. Turn the engine OFF.
4. Disconnect inlet hose at No. 2 reel motor.
5. Install tester in series between disconnected hose and reel motor (flow direction is from hose to motor). Make sure gate valve of tester is OPEN.
6. Position reel speed control knob at middle range (90 degree position).
7. Start engine and move throttle to full speed (2500 rpm).
8. Engage the reel control lever into "MOW."

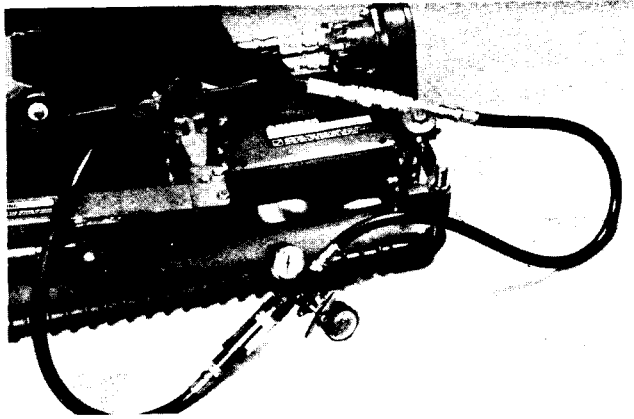

CAUTION

Reels will rotate when reel control lever is moved into the "MOW" position. Keep clear of rotating reels.

TESTER READING TO BE APPROXIMATELY 14 - 15 GPM.

9. If reel circuit oil flow is too low, check for restriction in pump intake line. If not restricted, remove pump and repair or replace as necessary.

TEST NO. 5: Checking Reel Motor Efficiency

Procedure:

1. Hydraulic oil must be at operating temperature.
2. Start the engine and lower the cutting unit to be checked.
3. Turn the engine OFF.
4. Block the reel to be checked to prevent rotation. Use a substantial hardwood block inserted between the reel blades.
5. Disconnect inlet hose at reel motor.
6. Install tester in series between disconnected hose and reel motor (flow direction is from hose to motor). Make sure gate valve of tester is OPEN.
7. Position reel speed control knob at minimum speed.
8. Start engine and move throttle to idle speed (1200 rpm).

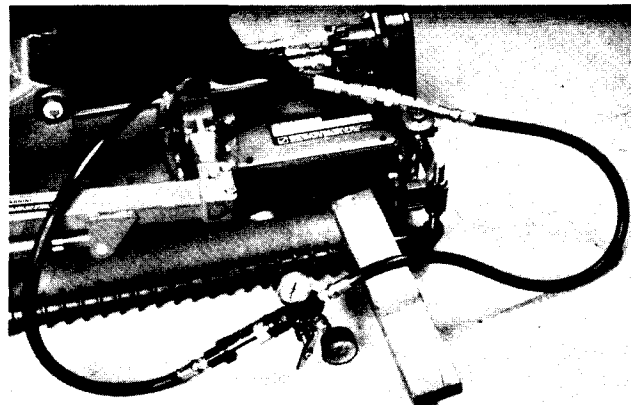

CAUTION

Stand clear of the reels during the following procedures:

9. Gently ease the reel control lever into "MOW" while monitoring the tester.

NOTE: It may be necessary to raise the throttle slightly to prevent the engine from stalling.

TESTER READING NOT TO EXCEED 1.5 GPM at 3000 psi.

10. If flow is above 1.5 GPM, remove motor and repair or replace as necessary. If pressure is higher than 3000 PSI or lower than 2700 PSI, clean or replace relief valve in reel control valve.

TEST NO. 6: Checking Steering Circuit Working Pressure Or Relief Pressure

Procedure For Working Pressure Check:

1. Install a 5000 psi gauge onto the steering quick disconnect.
2. Operate the unit while monitoring gauge.

RANGE OF TESTER READINGS 0 - 1500 psi.

3. If working pressure is too high or too low, perform relief pressure check.

Procedure For Relief Pressure Check:

1. Hydraulic oil must be at operating temperature.
2. Install a 5000 psi gauge onto the steering quick disconnect.
3. Start the engine and move the throttle to full speed (2500 rpm).
4. Turn the steering wheel until heavy resistance is felt indicating that the cylinder has reached maximum stroke.
5. Momentarily hold the steering wheel against the resistance and read gauge.

TESTER READING TO BE APPROXIMATELY 1500 PSI.

6. If pressure is too high, clean and adjust relief valve in steering pump by removing the required shims. If pressure is too low, check for restriction in pump intake line. Check the steering cylinder for internal leakage. If cylinder is not leaking, adjust the relief valve by adding the required shims. If pressure is still too low, repair or replace steering pump.

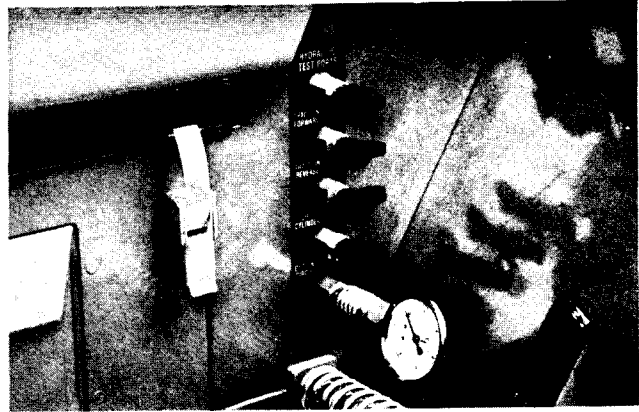

TEST NO. 7: Checking Lift Circuit Working Pressure Or Relief Pressure

Procedure For Working Pressure Check:

1. Install a 5000 psi gauge onto the quick disconnect of the lift valve. NOTE: The gauge must be installed directly into the cylinder line on units without a lift valve quick disconnect.



CAUTION

Cutting unit must be locked in the transport position before removing the cylinder line or cutting unit will drop suddenly.

2. Operate the unit while monitoring gauge.

RANGE OF TESTER READINGS 500 - 2750 psi.

3. If working pressure is too high or too low, perform relief pressure check.

Procedure For Relief Pressure Check:

1. Hydraulic oil must be at operating temperature.
2. Install a 5000 psi gauge onto the quick disconnect of the lift valve. NOTE: The gauge must be installed directly into the cylinder line on units without a lift valve quick disconnect.



CAUTION

Cutting unit must be locked in the transport position before removing the cylinder line or cutting unit will drop suddenly.

3. Start the engine and move throttle to full speed (2500 rpm).
4. Engage the control lever into the "LIFT" position. Momentarily hold the lever in the engaged position after full cylinder extension and read gauge.

TESTER READING TO BE APPROXIMATELY 2750 psi.

NOTE: Always set counterbalance pressure to desired amount before attempting to adjust lift pressure.

5. If pressure is too high, clean and adjust relief valve in lift valve by removing the required shims. If pressure is too low, check for restriction in pump intake line. Check the lift cylinder for internal leakage. If cylinder is not leaking, adjust the relief valve by adding the required shims. If pressure is still too low, repair or replace steering/lift pump.

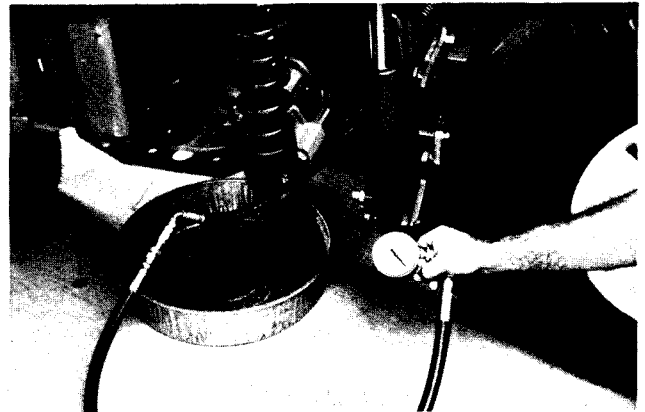

TEST NO. 8: Checking Charge Pressure For Traction Circuit

1. Hydraulic oil must be at operating temperature.
2. Install a 1000 psi gauge onto the quick disconnect at the top of the pump package.
3. Start the engine and position throttle at idle (1200 rpm).

TESTER READING TO BE APPROXIMATELY 50 - 150 psi.

4. If there is no pressure or pressure is too low, check for restriction in pump intake line. Inspect charge relief valve and valve seat. Check for sheared charge pump key. Disassemble charge pump and check for internal damage or worn parts. If the charge pump is in good condition (no scoring, scratches, or excessive wear), the general condition of the piston pump might be suspected of wear and inefficiency.

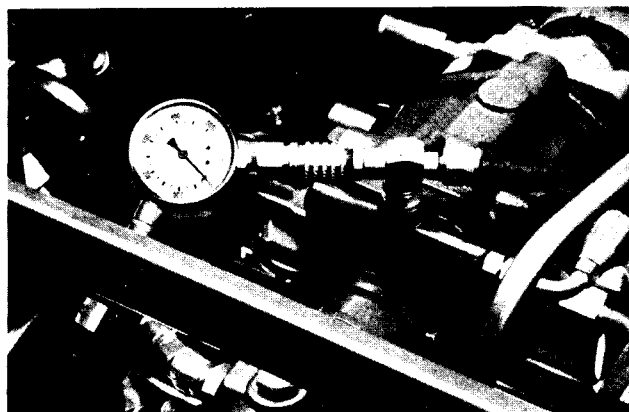

NO. 7-304

**Eaton
Hydraulics
Division**

Repair Information

Steering Control Units, Char-Lynn®

001

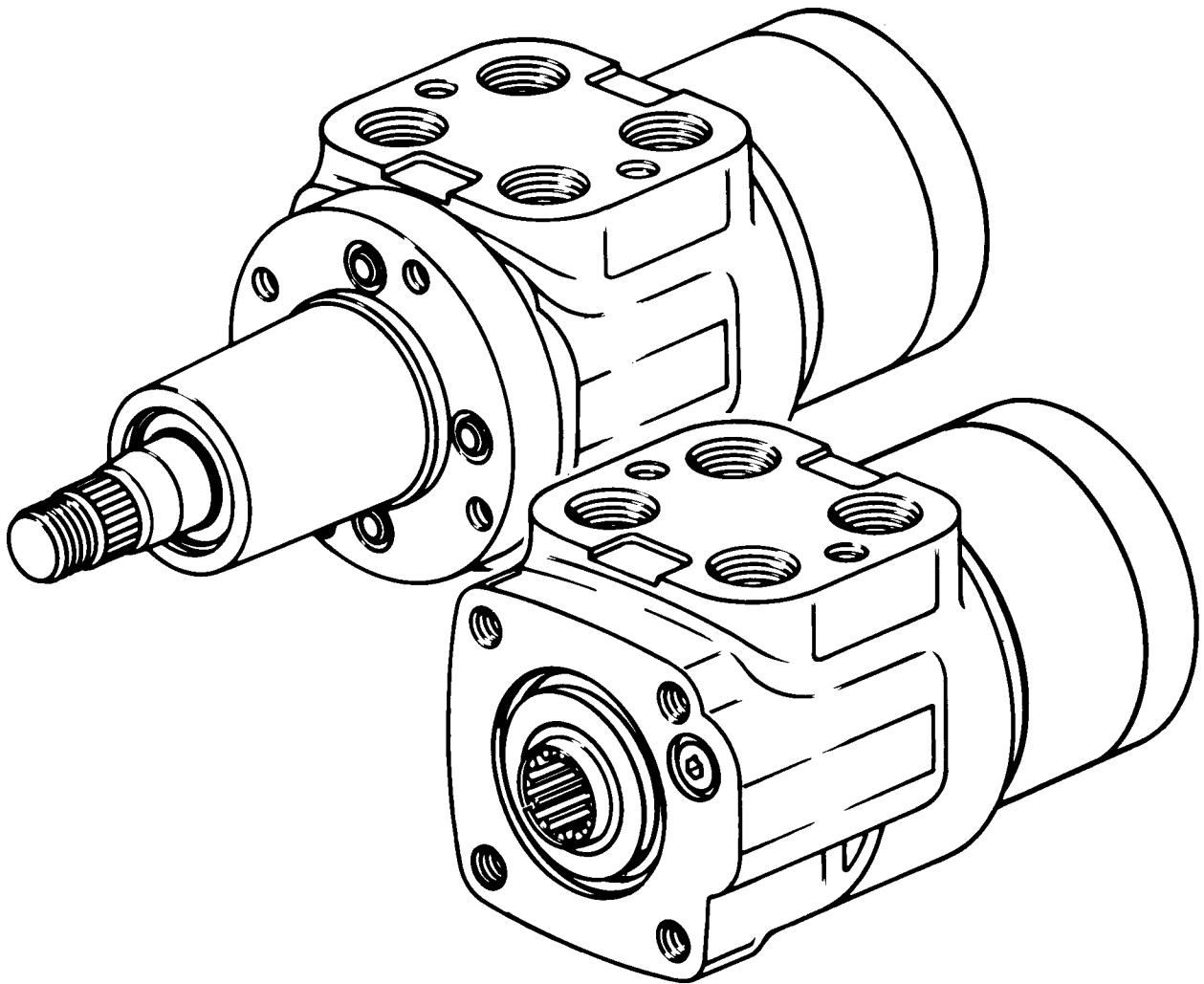

EAT•N



3

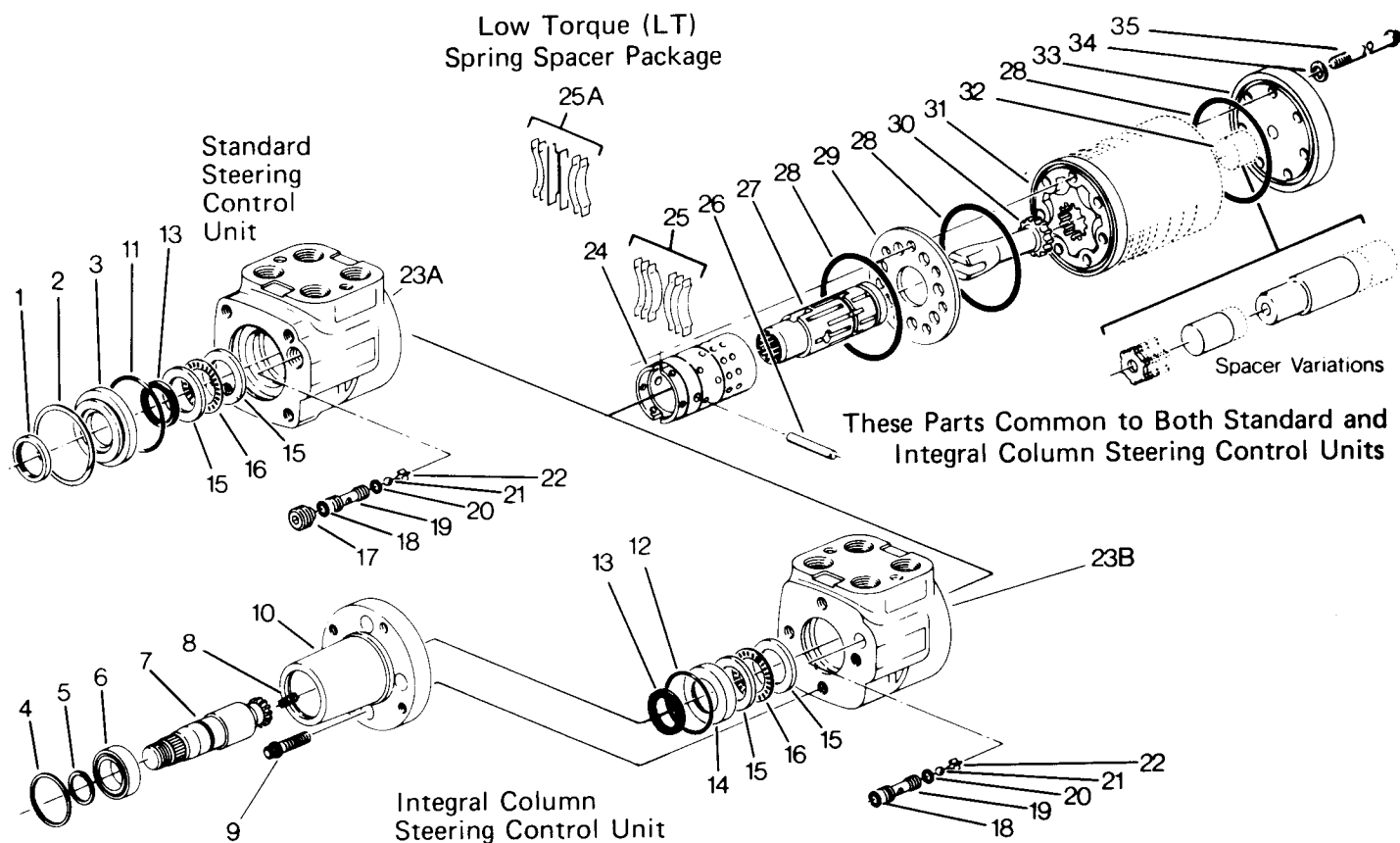

- 1. Dust Seal
- 2. Retaining Ring
- 3. Seal Gland Bushing
- 4. Retaining Ring
- 5. Retaining Ring
- 6. Control Column Bearing Ass'y
- 7. Control Shaft
- 8. Spring
- 9. Cap Screw
- 10. Steering Control Column
- 11. Seal, 2-1/8" OD
- 12. Seal, 1-15/16" OD

- 13. Quad Ring Seal
- 14. Bearing Locator
- 15. Bearing Race
- 16. Needle Thrust Bearing
- 17. Set Screw
- 18. Seal, 5/8" OD
- 19. Check Ball Seat
- 20. Seal, 7/16" OD
- 21. Check Ball
- 22. Check Ball Retainer
- 23A. Standard Housing
- 23B. Housing w/integral control column

- 24. Control Sleeve
- 25. Centering Springs
- 25A. Centering Springs and Spacers (LT)
- 26. Pin
- 27. Control Spool
- 28. Seal, 3" OD
- 29. Spacer Plate
- 30. Drive
- 31. Meter (Gerotor)
- 32. Spacer(s)
- 33. End Cap
- 34. Seal Washer
- 35. Cap Screw

See pages 10 thru 12 for disassembly and reassembly instructions covering the power steering integral control column.

Tools required for disassembly and reassembly.

- Screwdriver (4"-6" long, 1/8" flat blade)
- * 5/16" - 12 pt. socket 5422
- Breaker bar wrench
- Torque wrench (275 inch pound capacity)
- Plastic hammer or rubber hammer
- 1/4" Allen wrench
- #10-24 machine screw, 1-1/2" long.
- Needle nose pliers

The following tool isn't necessary for disassembly and reassembly, but is extremely helpful.

- *Spring installation tool 600057

* Tools available--by special order--through our service department.

Disassembly

Cleanliness is extremely important when repairing a steering control unit. Work in a clean area. Before disconnecting lines, clean port area of unit thoroughly. Use a wire brush to remove foreign material and debris from around exterior joints of the unit.

Note: Trouble shooting information on pages 13, 14, and 15 defines terms and problems, possible causes for problems, and recommends procedures for correcting problems.

Although not all drawings show the unit in a vise, we recommend that you keep the unit in the vise during disassembly. Follow the clamping procedures explained throughout the manual.

Meter (Gerotor) End

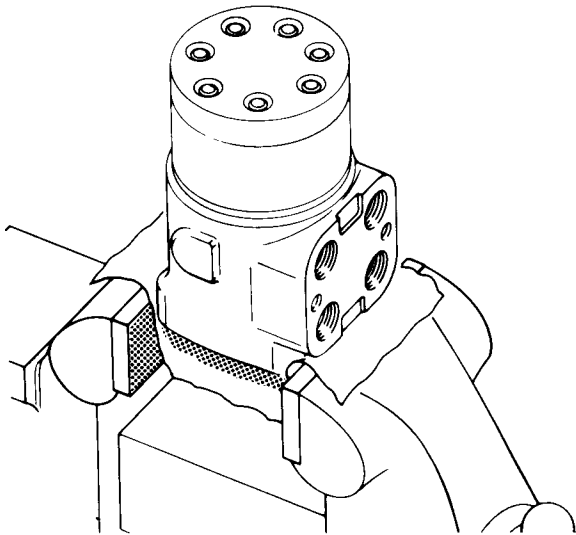

Figure 1

1 Clamp unit in vise, meter end up. Clamp lightly on edges of mounting area, see Fig. 1. Use protective material on vise jaws. Housing distortion could result if jaws are overtightened.

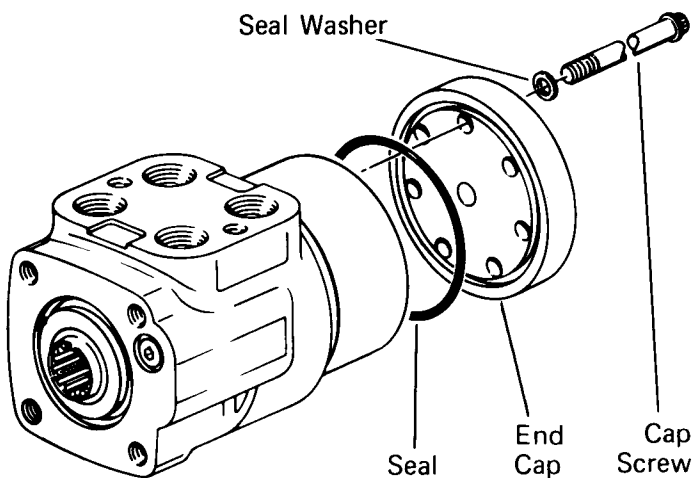

Figure 2

4

- 2 Remove 5/16" cap screws.
- 3 Remove end cap.
- 4 Remove seal from end cap.

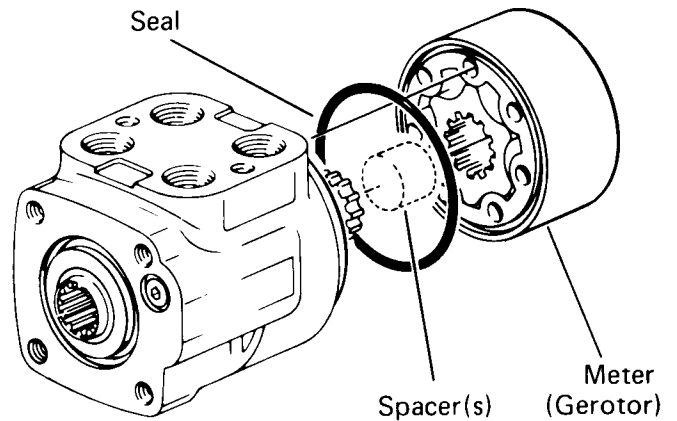

Figure 3

- 5 Remove meter. Be careful not to drop star.
- 6 Remove seal from meter.
- 7 Remove drive spacer(s) (not used on 4.5 cu. in displacement units).

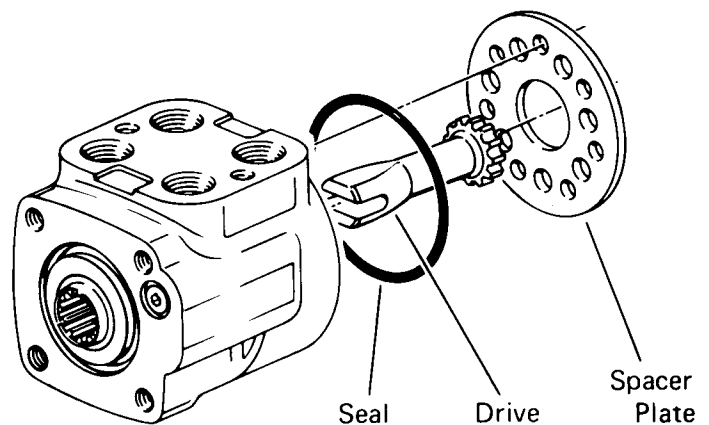

Figure 4

- 8 Remove drive.
- 9 Remove spacer plate.
- 10 Remove seal from housing.

Control End

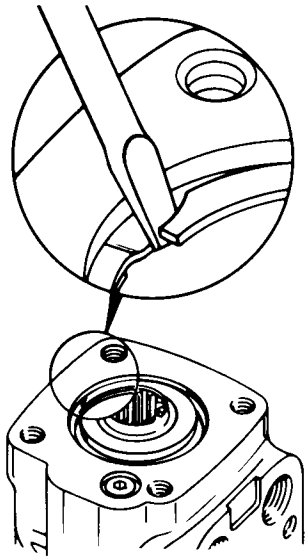

Figure 5

11 Remove housing from vise. Place housing on a clean soft cloth to protect surface finish. Use a thin bladed screwdriver to pry retaining ring from housing, as shown in Fig. 5.

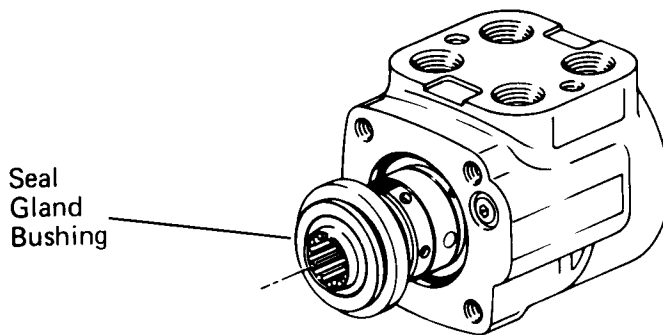

Figure 6

12 Rotate spool and sleeve until pin is horizontal. Push spool and sleeve assembly forward with your thumbs just far enough to free gland bushing from housing, see Fig. 6. Remove bushing

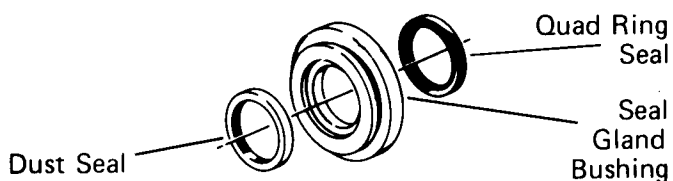

Figure 7

13 Remove quad ring seal from seal gland bushing.

14 Use a thin bladed screwdriver to pry dust seal from seal gland bushing. Do not damage bushing.

Note: If the unit you are repairing is a low input torque steering control unit, see page 12 for disassembly and reassembly procedures.

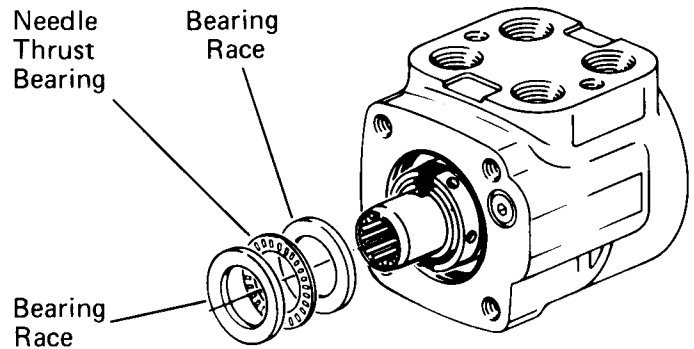

Figure 8

15 Remove 2 bearing races and the needle thrust bearing from spool and sleeve assembly.

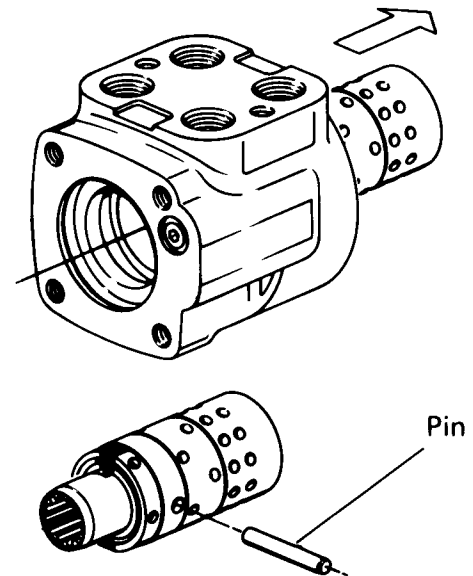

Figure 9

16 Remove spool and sleeve assembly from 14 hole end of housing, see Fig. 9.

Attention: Do not bind spool and sleeve in housing. Rotate spool and sleeve assembly slowly when removing from housing.

17 Push pin from spool and sleeve assembly.

Disassembly

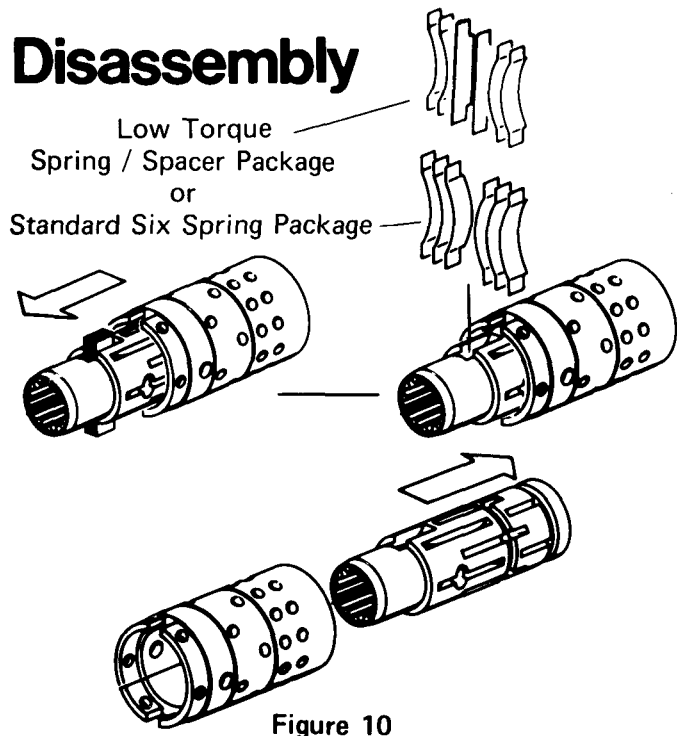

Figure 10

18 Push spool partially from control end of sleeve, then remove 6 centering springs from spool carefully by hand, see Fig. 10.

19 Push spool back through and out of sleeve, see Fig. 10. Rotate spool slowly when removing from sleeve.

20 Remove seal from housing, see Fig. 11.

6

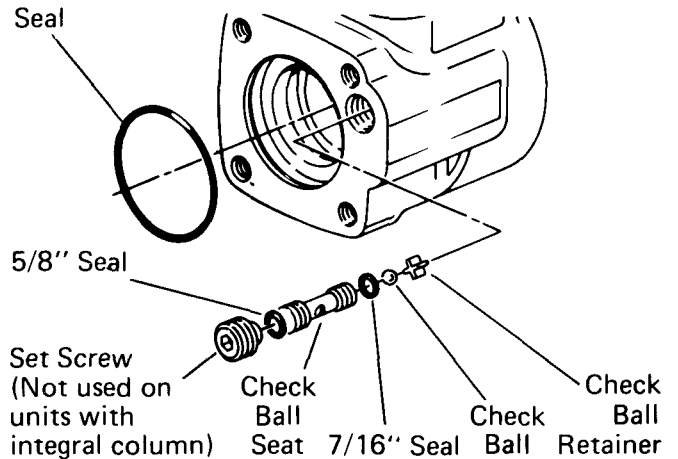

Figure 11

21 Remove set screw (not used on units with integral column) from housing, see Fig. 11.

22 Screw a # 10-24 machine screw into end of check ball seat. Then by pulling on screw, with a pliers, lift seat out of housing.

23 Remove 2 seals from check valve seat.

24 Tip housing to remove check ball and check ball retainer.

Reassembly

Check all mating surfaces. Replace any parts that have scratches or burrs that could cause leakage. Clean all metal parts in clean solvent. Blow dry with air. Do not wipe dry with cloth or paper towel because lint or other matter can get into the hydraulic system and cause damage. Do not use a coarse grit or try to file or grind these parts.

Note: Lubricate all seals with clean petroleum jelly such as Vaseline.

Do not use excessive lubricant on seals for meter section.

Refer to parts listings covering your steering control unit when ordering replacement parts. A good service policy is to replace all old seals with new seals.

Control End

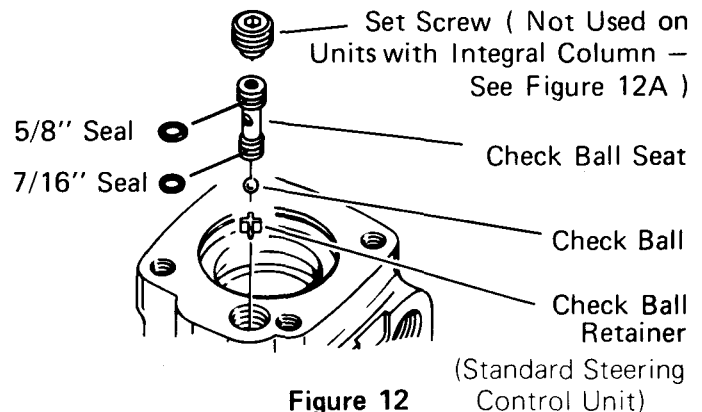

Figure 12

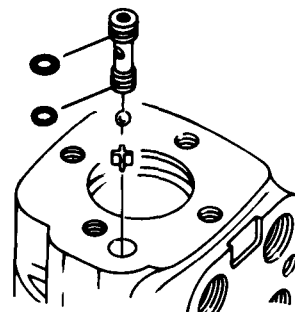

Figure 12A

(Integral Column Steering Control Unit)

- 1 Use a needle nose pliers to lower check ball retainer into check valve hole of housing. Make sure retainer is straight (not tilted on edge) in housing, see Fig. 12.
- 2 Install check ball in housing.
- 3 Lubricate 5/8" diameter seal and 7/16" diameter seal. Install seals on check ball seat as shown in Fig. 12.
- 4 Lubricate check ball seat and seals thoroughly before installing seat in housing. When installing seat do not twist or damage seals. Install check ball seat in housing, insert open end of seat first, see Fig. 12. Push check ball seat to shoulder of hole.
- 5 Install set screw (not used on units with integral column, see Fig. 12A). Use a 1/4" allen wrench to torque set screw to 100 inch pounds. To prevent interference, make sure top of set screw is slightly below housing mounting surface.

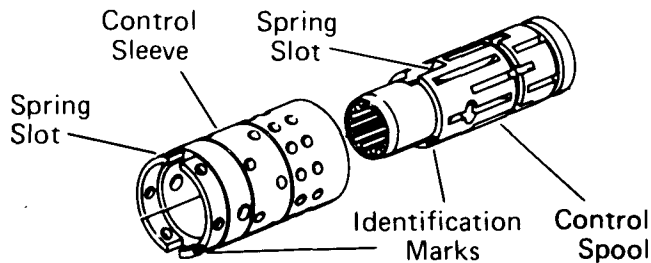

Figure 13

- 6 Assemble spool and sleeve carefully so that the spring slots line up at the same end. Rotate spool while sliding parts together. Some spool and sleeve sets have identification marks, align these marks as shown in Fig. 13. Test for free rotation. Spool should rotate smoothly in sleeve with finger tip force applied at splined end.

Low Input Torque
Spring/Spacer Installation
Information — See
Steps 1-6 Page 12

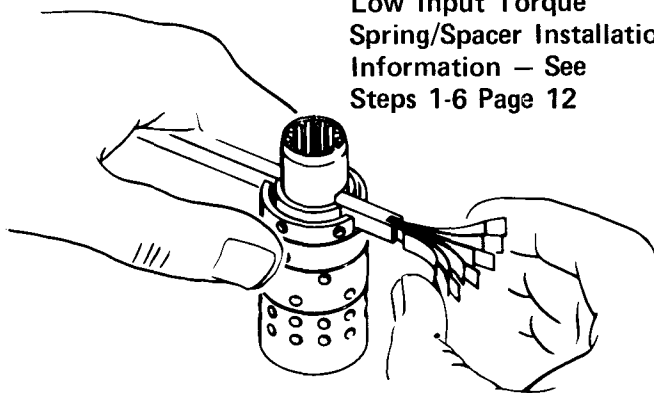

Figure 14

- 7 Bring spring slots of both parts in line and stand parts on end of bench. Insert spring installa-

tion tool through spring slots of both parts. Tool is available as part no. 600057. Position 3 pairs of centering springs (or 2 sets of 3 each) on bench so that extended edge is down and arched center section is together. In this position, insert one end of entire spring set into spring installation tool, as shown in Fig. 14, with spring notches facing sleeve.

- 8 Compress extended end of centering spring set and push into spool sleeve assembly withdrawing installation tool at the same time.

- 9 Center the spring set in the parts so that they push down evenly and flush with the upper surface of the spool and sleeve.

- 10 Install pin through spool and sleeve assembly until pin becomes flush at both sides of sleeve.

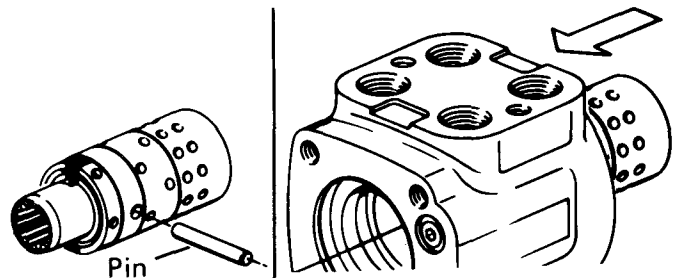

Figure 15

Figure 16

- 11 Position the spool and sleeve assembly so that the splined end of the spool enters the 14 hole end of housing first, see Fig. 16.

Attention: Be extremely careful that the parts do not tilt out of position while inserting. Push parts gently into place with slight rotating action, keep pin nearly horizontal. Bring the spool assembly entirely within the housing bore until the parts are flush at the meter end or 14 hole end of housing. Do not pull the spool assembly beyond this point to prevent the cross pin from dropping into the discharge groove of the housing. With the spool assembly in this flush position, check for free rotation within the housing by turning with light finger tip force at the splined end.

Reassembly

8

12 Place housing on clean, lint free cloth. Install 2-1/8" diameter seal in housing, see Fig. 17.

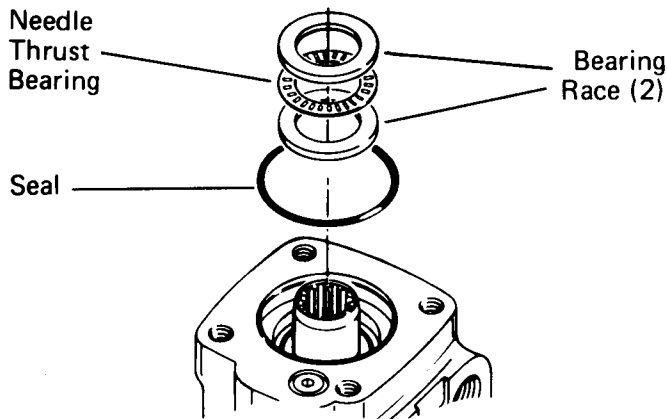

Figure 17

13 Install 2 bearing races and the needle thrust bearing in the order shown in Fig. 17.

14 Install 1-1/4" diameter dust seal in seal gland bushing, flat or smooth side of dust seal must face down towards bushing, see Fig. 19.

15 Install the quad ring seal in seal gland bushing. Smooth seal in place with your finger. Do not use any seal that falls freely into pocket of bushing, see Fig. 19.

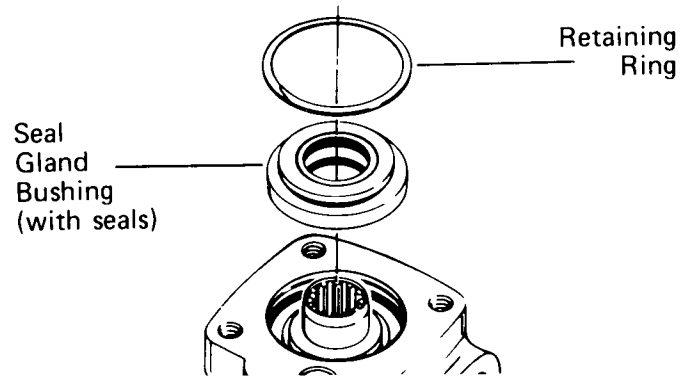

Figure 18

16 Install seal gland bushing over the spool end with a twisting motion. Tap the bushing in place with a rubber hammer. Make sure the bushing is flush against the bearing race.

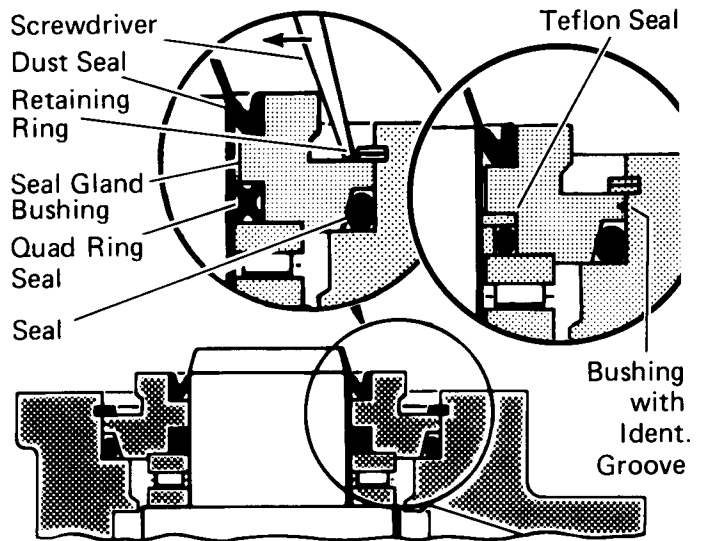

Figure 19

17 Install retaining ring (see Fig. 18-19) in housing. After installing ring, tap on ring end or pry with screwdriver around entire circumference of ring to properly seat ring in groove.

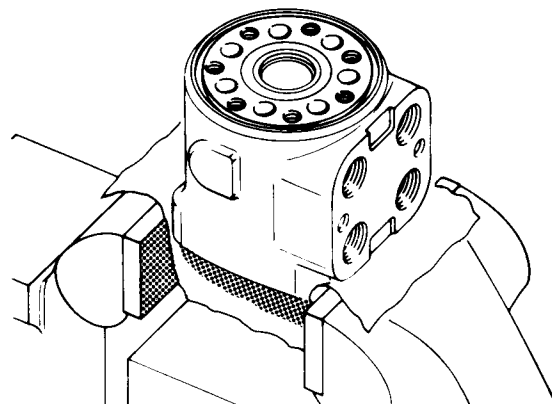

Figure 20

18 Clamp housing in vise, as shown in Fig. 20. Clamp lightly on edges of mounting area. Do not over tighten jaws.

Note: Check to insure that the spool and sleeve are flush or slightly below the 14 hole surface of the housing.

Attention: Clean the upper surface of the housing by wiping with the palm of clean hand. Clean each of the flat surfaces of the meter section parts in a similar way when ready for reassembly. Do not use cloth or paper to clean surfaces.

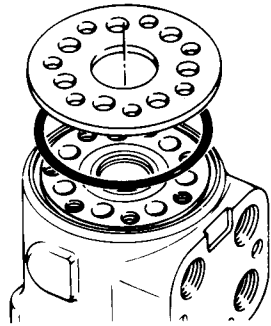

Figure 21

19 Install 3" diameter seal in housing, see Fig. 21.

20 Install spacer plate. Align bolt holes in spacer plate with tapped holes in housing.

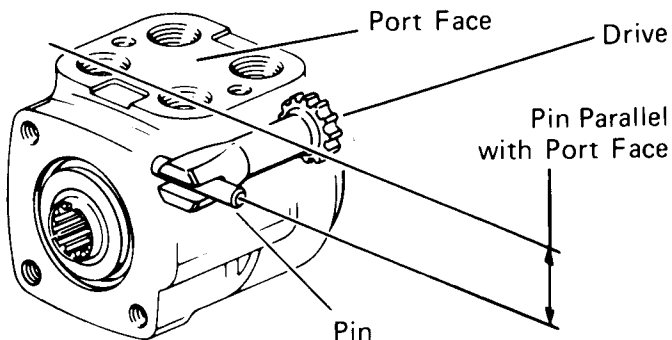

Figure 22

21 Rotate spool and sleeve assembly until pin is parallel with port face, see Fig. 22. Install drive, make sure you engage drive with pin, To assure proper alignment, mark drive as shown in Fig. 24 (ref. B). Note relationship between slotted end of drive to splined end of drive when marking.

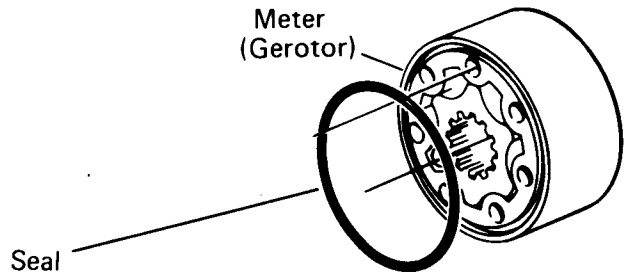

Figure 23

22 Install 3" diameter seal in meter.

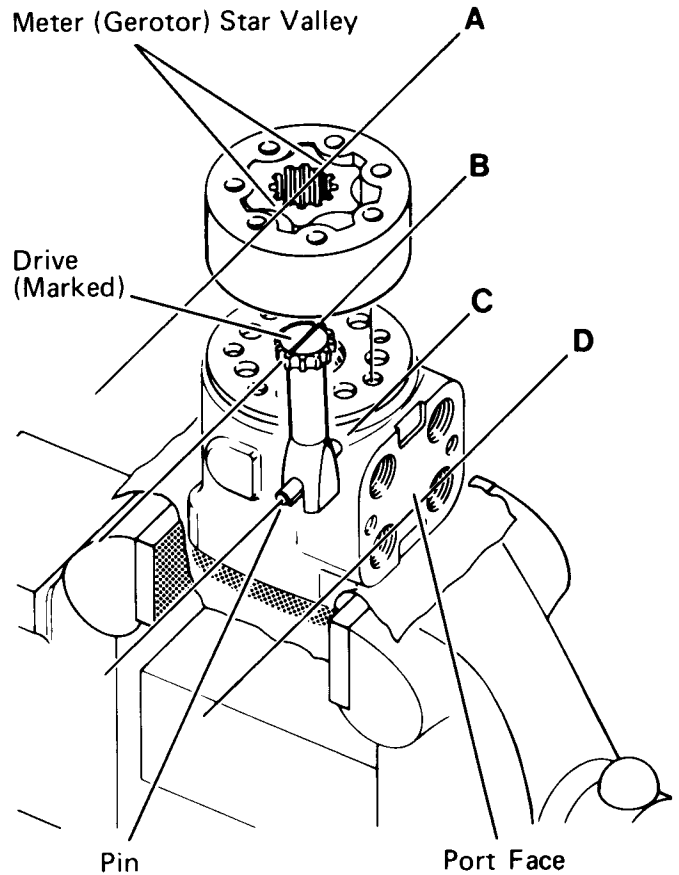
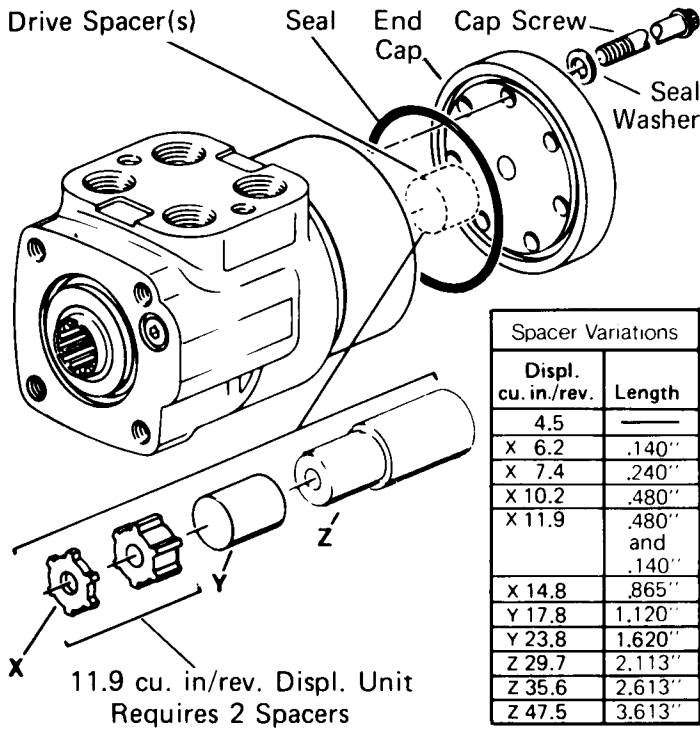

Figure 24

23 With seal side of meter toward spacer plate, align star valleys (ref. A) on drive (ref. B). Note the parallel relationship of reference lines A, B, C, and D— Fig. 24. Align bolt holes without disengaging meter from drive.

Reassembly



Spacer Variations	
Displ. cu. in./rev.	Length
4.5	—
X 6.2	.140"
X 7.4	.240"
X 10.2	.480"
X 11.9	.480" and .140"
X 14.8	.865"
Y 17.8	1.120"
Y 23.8	1.620"
Z 29.7	2.113"
Z 35.6	2.613"
Z 47.5	3.613"

Figure 25

10

24 Install drive spacer(s) when used, in meter, see Fig. 25.

25 Install 3" diameter seal in end cap.

26 Install end cap on gerotor, align holes.

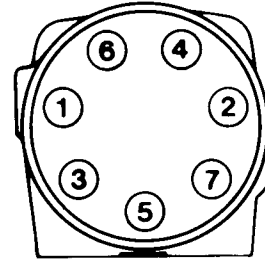

Figure 26

27 Install 7 dry cap screws with new seal washers in end cap. Pretighten screws to 150 inch pounds, then torque screws to 275 inch pounds in sequence shown in Fig. 26.

Disassembly

Disassembly of Integral Column Sub Assembly

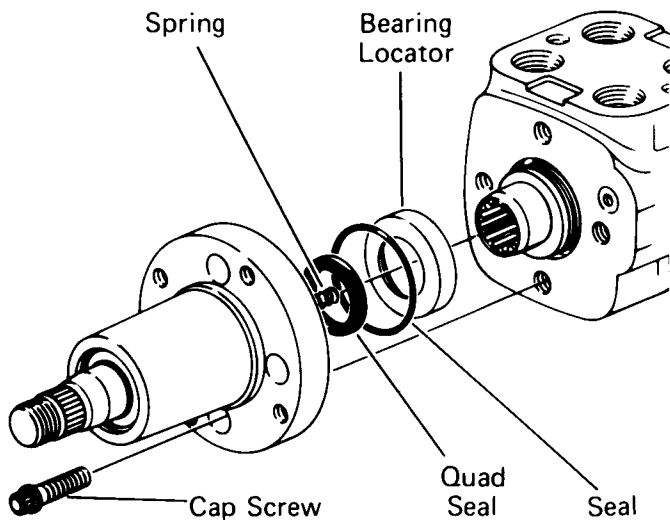

Figure 27

- 1 Remove 4 cap screws from column.
- 2 Remove column and spring, see Fig. 27.
- 3 Remove bearing locator.
- 4 Remove quad ring seal, and 1-15/16" diameter seal from column.

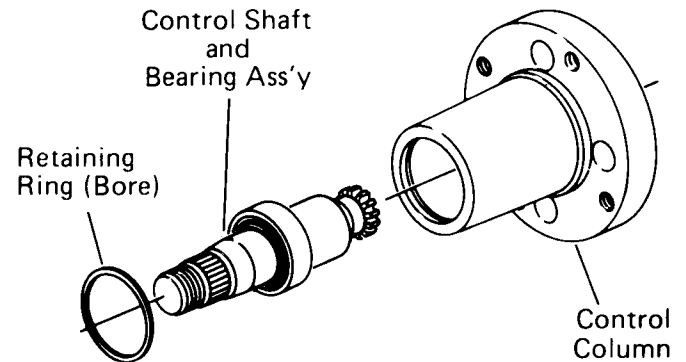

Figure 28

5 Use a thin bladed screwdriver to pry retaining ring from bore of control column.

6 Remove control shaft and bearing assembly from column, see Fig. 28. If tight, tap lightly with a plastic hammer or rubber hammer) on splined end of control shaft until the shaft breaks loose from the column.

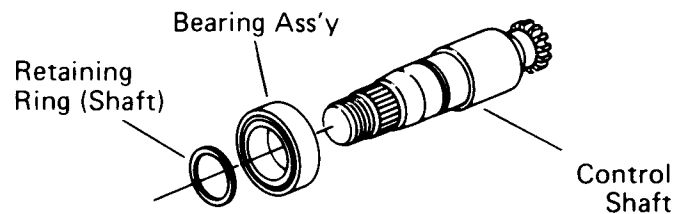

Figure 29

Disassembly

7 Use a thin bladed screwdriver to pry retaining ring from shaft. The retaining ring fits very tight, be careful not to distort it. Remove this ring only if it's necessary to remove bearing assembly from shaft, see Fig. 29.

11

8 Press bearing assembly from control shaft. Remove bearing assembly from threaded end of shaft, see Fig. 29. Remove this bearing assembly only if necessary.

Reassembly

Reassembly of Integral Column Sub Assembly

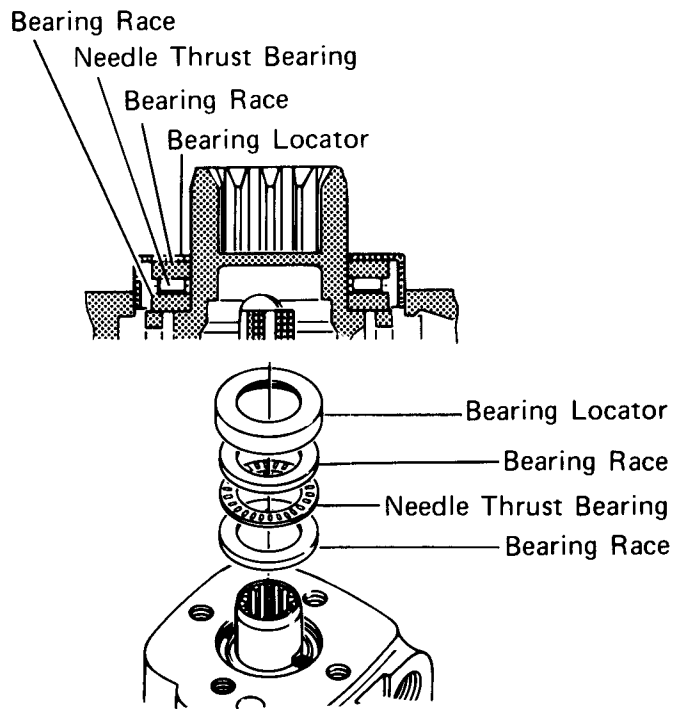

Figure 30

1 Install bearing locator over 2 bearing races and the needle thrust bearing, see Fig. 30. Use a soft plastic hammer or rubber hammer to lightly tap bearing locator in housing.

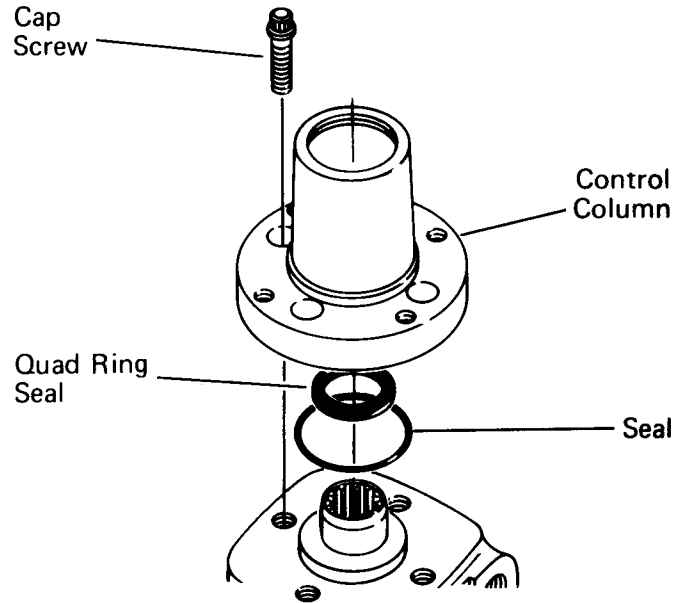

Figure 31

2 Install dry quad ring seal, and lubricated 1-15/16" diameter seal in column, see Fig. 31.

3 Install column on housing. Align bolt holes.

4 Install 4 dry cap screws. Torque screws in a criss-cross pattern to 200 inch pounds.

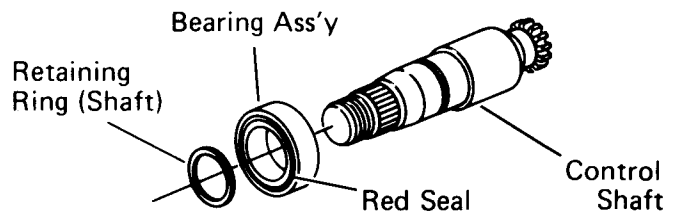

Figure 32

5 Press bearing assembly on control shaft with seal (red) side of bearing assembly facing toward threaded end of shaft. Make sure the bearing assembly seats against shoulder of shaft.

6 Install retaining ring on control shaft, see Fig. 32. Make sure ring seats properly in ring slot above bearing assembly.

Reassembly

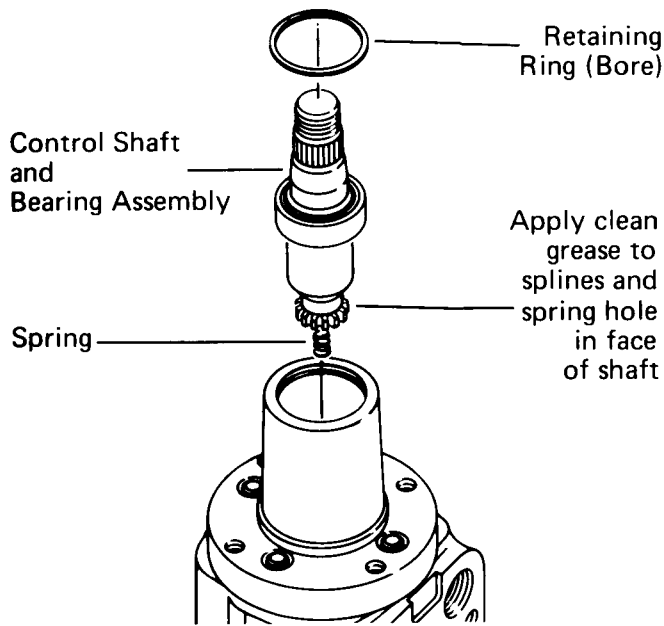

Figure 33

7 Apply clean grease to splines and spring hole located in face of control shaft, see Fig. 33. Install spring in hole. The grease should hold the spring in place until you install control shaft in column.

8 Install control shaft and bearing assembly in column (insert splined end of control shaft in column first), see Fig 33. Turn shaft to engage with spool. Push bearing assembly in far enough so you can install retaining ring in bore of column.

9 Install retaining ring in bore of column. Make sure you fully seat this retaining ring in ring groove.

How to order replacement parts.

Each order must include the following information:

1. Product Number
2. Date Code
3. Part Name
4. Part Number
5. Quantity of Parts

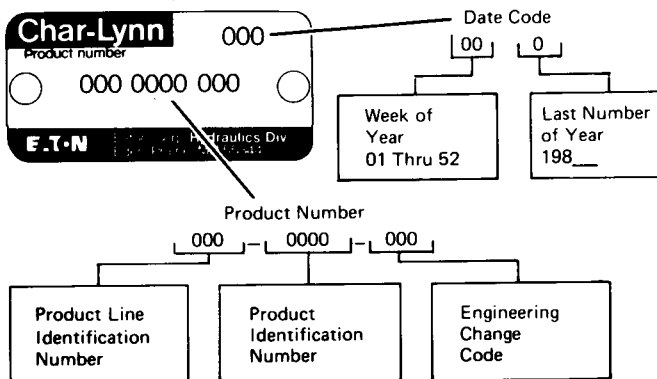

12

Low Input Torque Steering Control Unit

1 After disassembling steering control unit, discard quad-ring seal, seal gland bushing and two centering springs. Seal gland bushings for Teflon seal and quad-ring seal are not interchangeable.

2 Low torque steering control unit has one pair of spring spacers and two pairs of centering springs. Install spring spacers between two sets of centering springs. The installation procedure is the same as that used on the standard units.

3 Install Teflon seal, o-ring and back-up ring on the spool, see Figure X.

Note: Apply a light coat of hydraulic oil to all seals before installation.

4 Install dust seal in seal gland bushing, flat or smooth side down. This bushing has identification groove in outer diameter. Non-grooved bushing cannot be used with Teflon seal.

5 Install seal gland bushing over spool end with a twisting motion. Tap bushing in place with a rubber hammer. Make sure bushing is flush against bearing race.

6 Install retaining ring (see Figure X) in housing. After installing ring , tap on ring end or pry with screwdriver around entire circumference of ring to properly seat ring in groove.

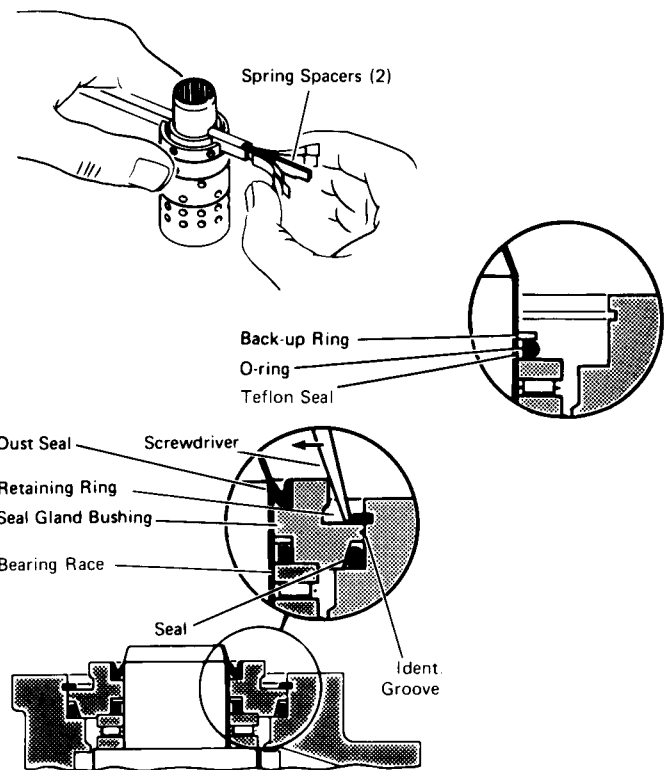

Figure X

Most steering problems can be corrected if the problem is properly defined. The entire steering system should be evaluated before removing any components. The steering control unit is generally not the cause of most steering problems. The following is a list of steering problems along with possible causes and suggested corrections.

<u>Problem</u>	<u>Possible Cause</u>	<u>Correction</u>
1. Slow steering, hard steering, or loss of power assist.	Worn or malfunctioning pump.	Replace pump.
	Stuck flow divider piston.	Replace flow divider.
	Worn pump compensator allowing the system pressure to be less than specified.	Replace pump and compensator.
	Malfunctioning relief valve allowing the system pressure to be less than specified.	Replace the relief valve.
	Overloaded steer axle.	Reduce load.
2. Wander—Tendency of vehicle path to deviate from course defined by operator input.	If load sensing system <ol style="list-style-type: none"> 1. Leaking or kinked load sensing signal line. 2. Malfunctioning priority valve. 	Correct Check spring and sticking spool. Check damping orifices in both ends of main bore for debris. Check system pressure at SCU inlet for proper system pressure. If not correct replace priority valve relief cartridge.
	Air in the system due to low level of oil, cavitating pump, leaky fitting, pinched hose, etc.	Correct condition and add fluid.
3. Drift—Diviation of vehicle path, without operator input, from normally expected continuing course.	Worn mechanical linkage.	Repair or replace.
	Bending of linkage or cylinder rod.	Repair or replace.
	Loose cylinder piston.	Repair or replace.
	Leaky crossover relief or anti-cavitation valve in cylinder lines.	Repair or replace the accessory valve.
	Severe wear in steering control unit.	Replace the steering control unit.
4. Slip—A slow movement of steering wheel fails to cause any movement of steered wheels.	Single rod end cylinder slowly extends without turning the steering wheel.	A small rate of extension may be normal on a closed center system.
	Worn or damaged steering linkage.	Replace linkage and align front end.
5. Temporary hard steering or hang-up—A momentary increase in steering wheel torque during steering reversal or initial input.	Leakage of cylinder piston seals or accessory valve between cylinder lines or ports.	Replace seals or accessory valve.
	Worn steering control unit meter.	Replace steering control unit.
	Thermal Shock*	Check unit for proper operation and cause of thermal shock.

*Thermal shock definition bottom of page 14.

<u>Problem</u>	<u>Possible Cause</u>	<u>Correction</u>
6. Erratic steering.	Air in system due to low level of oil, cavitating pump, leaky fitting, pinched hose, etc.	Correct condition and add fluid.
	Loose cylinder piston.	Replace cylinder.
	*Thermal shock damage.	Replace steering control unit.
7. "Spongy" or soft steering.	Sticking flow control spool.	Replace flow control valve.
	Air in hydraulic system. Most likely air trapped in cylinders or lines.	Bleed air out of system. Placing ports on top of the cylinder will help prevent air trapping.
8. Free Wheeling—Steering wheel turns freely with no feeling of pressure and no action on steered wheels.	Low fluid level.	Add fluid and check for leaks.
	Steering column upper shaft is loose or damaged.	Tighten steering wheel nut.
8. Free Wheeling—Steering wheel turns freely with no feeling of pressure and no action on steered wheels.	Lower splines of column may be disengaged or broken.	Repair or replace column.
	Steering control unit meter has a lack of oil. This can happen on start-up, after repair, or long periods of non use.	Usually starting engine will cure problem.
	No flow to steering unit can be caused by: 1. Low fluid level. 2. Ruptured hose. 3. Internal steering control unit damage due to thermal shock*.	Add fluid and check for leaks. Replace hose. Replace the unit.
9. Free Wheeling—Steering wheel turns with slight resistance but results in little or no steered wheel action.	Leaking crossover relief or anti-cavitation valve in cylinder lines.	Repair or replace the accessory valve.
	Piston seal blown out.	Determine cause. Correct and replace seal.
10. Excessive free play at steering wheel.	Loose steering wheel nut. Steering column shaft worn or damaged. There should be very little free play in the unit itself.	Repair or replace steering wheel connection or column.
11. Excessive free play at steered wheels.	Broken or worn linkage between cylinder and steered wheels.	Check for loose fitting bearings and anchor points in steering linkage between cylinder and steered wheels.
	Leaky cylinder seals.	Replace cylinder seals.

*Thermal shock—A condition caused when the hydraulic system is operated for some time without turning the steering wheel so that fluid in the reservoir and system is hot and the steering control unit is relatively cool (more than 50° F temperature differential). When the steering wheel is turned quickly the result is temporary seizure and possible damage to internal parts of the steering control unit. The temporary seizure may be followed by total free wheeling. This applies to closed center and load sensing units only.

<u>Problem</u>	<u>Possible Cause</u>	<u>Correction</u>
12. Binding or poor centering of steering wheel.	Binding or misalignment in steering column or splined input connection.	Align column pilot and spline to steering control unit.
	High back pressure in tank line can cause slow return to center. Should not exceed 300 psi.	Revise circuit return line.
	Large particles can cause binding between the spool and sleeve.	Clean the unit and filter the oil. If another component has failed generating contaminants, flush the system while bypassing the steering control unit.
13. Steering unit locks up.	Large particles in meter section.	Clean the unit.
	Insufficient hydraulic power (units over 15 cu. in./rev.)	Check hydraulic power supply.
	Severe wear and/or broken pin.	Replace the unit.
	*Thermal shock.	Replace the unit.
14. Steering wheel oscillates or turns by itself, either side of neutral, after operator has removed input.	Parts assembled wrong. Steering unit improperly timed.	Correct timing.
	Lines connected to wrong ports.	Reconnect lines correctly.
15. Steered wheels turn in wrong direction when operator activates steering wheel	Lines connected to wrong cylinder ports.	Reconnect lines correctly.
16. Kick—Momentary kick back of steering wheel at start of steering.	No inlet check valve on steering control unit.	Install a check valve.
17. Instability—Fluid-born oscillation.	Air in lines	Check pump inlet. Bleed sensing lines.
	Harmonic system	Add hose or an accumulator.
	Plumbing	Bleed all lines. Pilot lines should be tubing. lines to cylinder should be tubing. If 2 pilot lines are used go to 1.
	Relief Setting	Pump relief should be 300 PSI above priority relief.
	Priority Valve	Bleed by holding against stop for 30 seconds on models w/built in relief only. Decrease damping orifice by adding small wire.
		Increase spring rate (this will raise the standby pressure).
	Load Sensing Pump	Compensator sticky. Increase standby pressure.

*Thermal shock definition bottom of page 14.

Selection Data

3 Series

System	Load Circuit	Rated Flow GPM ★ [LPM]	Port Size	External Configuration	Product Number						
					Displacement-cu. in. rev. [cu. cm. rev.]						
					4.5 [75]	6.2 [100]	7.4 [120]	10.2 [165]	11.9 [195]	14.8 [240]	17.8 [290]
Open Center	Non-Load Reaction	2-4 [7.5-15]	9/16-18	Standard	211-1001	211-1002	211-1003	-	-	-	-
				Integral Column	211-1004	211-1005	211-1006	-	-	-	-
Closed Center	Non-Load Reaction	2-4 [7.5-15]	9/16-18	Standard	212-1009	212-1010	212-1011	212-1012	-	-	-
	Load Reaction	2-4 [7.5-15]	9/16-18	Standard	212-1021	212-1022	212-1023	212-1024	-	-	-
				Integral Column	212-1025	212-1026	212-1027	212-1028	-	-	-

6 Series

System	Load Circuit	Rated Flow GPM ★ [LPM]	Port Size	External Configuration	Displacement-cu. in. rev. [cu. cm. rev.]						
					Displacement-cu. in. rev. [cu. cm. rev.]						
					4.5 [75]	6.2 [100]	7.4 [120]	10.2 [165]	11.9 [195]	14.8 [240]	17.8 [290]
Open Center	Non-Load Reaction	4-8 [15-30]	3/4-16	Standard	211-1007	211-1008	211-1009	211-1010	211-1011	211-1012	211-1013
				Integral Column	211-1014	211-1015	211-1016	211-1017	211-1018	211-1019	211-1020
Open Center	Load Reaction	4-8 [15-30]	3/4-16	Standard	211-1047	211-1048	211-1049	211-1050	211-1051	211-1052	211-1053
Closed Center	Non-Load Reaction	12 [45]	3/4-16	Standard	212-1001	212-1002	212-1003	212-1004	212-1005	212-1006	212-1007
	Load Reaction	8 [30]	3/4-16	Standard	-	-	-	212-1018	212-1019	212-1020	
Load Sensing	Non-Load Reaction	6 [23]	3/4-16	Standard	213-1001	213-1002	213-1003	213-1004	213-1005	213-1006	213-1007

12 Series

System	Load Circuit	Rated Flow GPM ★ [LPM]	Port Size	External Configuration	Displacement-cu. in. rev. [cu. cm. rev.]						
					Displacement-cu. in. rev. [cu. cm. rev.]						
					17.8 [290]	23.8 [390]	29.7 [490]	35.6 [585]	47.5 [780]		
Open Center	Non-Load Reaction	8-16 [30-60]	3/4-16	Standard	211-1037	211-1038	211-1039	211-1040	211-1041	-	-
				Integral Column	211-1042	211-1043	211-1044	211-1045	211-1046	-	-
Closed Center	Non-Load Reaction	16 [60]	3/4-16	Standard	-	212-1014	212-1015	212-1016	212-1017	-	-
Load Sensing	Non-Load Reaction	12 [45]	3/4-16	Standard	213-1012	213-1013	213-1014	213-1015	213-1016	-	-

Other combinations of the above standard features available on special order—consult factory

★For closed center unit, rated flow is measured at 1000 PSI pressure drop at full valve deflection.

For load sensing unit, rated flow is designed for 65 PSI pressure drop between inlet (P) and load sensing (LS) port at full valve deflection.



**Cessna
Service Instructions**

Reelmaster[®] 450-D





TORO Part No. 58-5440

Reel Motor

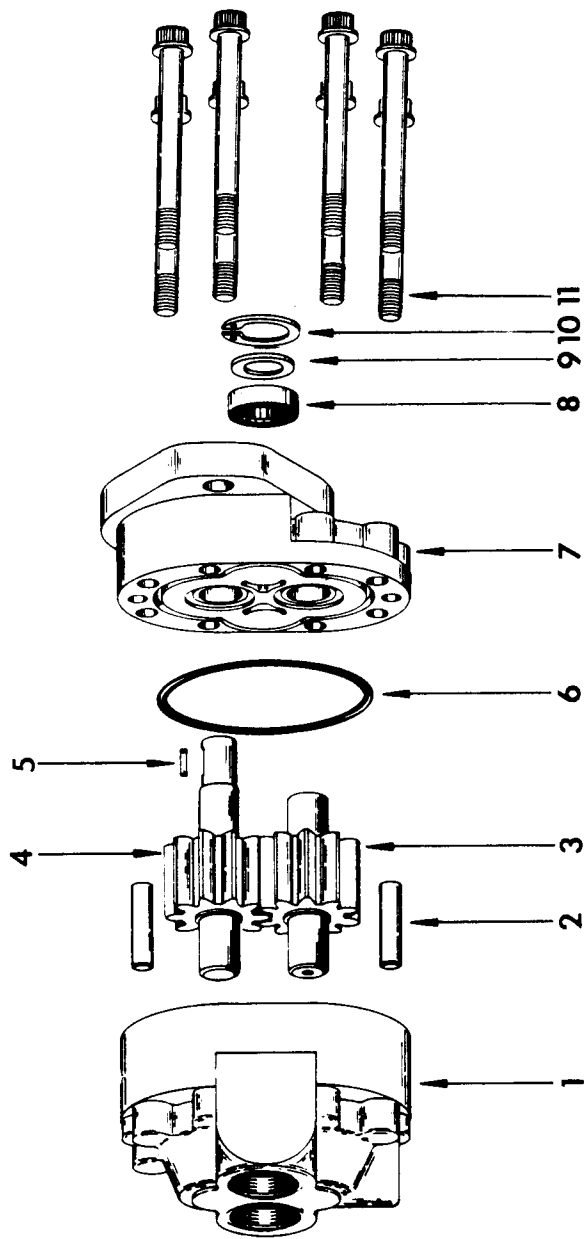

SERVICE INSTRUCTIONS
FOR THE
GEAR MOTOR ASSEMBLY

DISASSEMBLY

1. Remove key (5) from drive shaft.
2. Clean outside of motor thoroughly. Scribe a line along front plate and housing assembly to assure proper reassembly.
3. Clamp motor in vise, shaft up.
4. Remove eight cap screws (11).
5. Remove motor from vise, hold motor in hands and bump shaft against wooden block to separate housing assembly (1) from front plate assembly (7).
6. Remove drive gear assembly (4) and idler gear assembly (3).
7. Remove snap ring (10), back-up washer (9), shaft seal (8), and o-ring (6) from front plate (7).

INSPECTION

GENERAL

1. Clean and dry all parts.
2. Remove nicks and burrs from all parts with emery cloth.

GEAR ASSEMBLY

1. Inspect drive gear assembly (4) for broken or cracked keyway.
2. Inspect both the drive gear (4) and idler gear (3) shafts at bearing points for rough surfaces and excessive wear.
3. If shaft measures less than .686 in bearing area, the gear assembly should be replaced. (One gear assembly may be replaced separately.) (Shafts and gears are available as assemblies only.)
4. If gear width is below 1.327, gear assembly should be replaced.
5. Inspect gear face for scoring and excessive wear.
6. Snap rings on shaft assemblies should be in groove.

7. If edge of gear teeth are sharp, break edge with emery cloth.

HOUSING AND FRONT PLATE

1. Inspect I.D. of bushings in housing (1) and front plate (7). If I.D. exceeds .693, housing (1) or front plate (7) should be replaced. (Bushings are not available as separate items.)
2. Housing assembly should be replaced if I.D. of gear pocket exceeds 1.719.
3. Check for scoring on face of housing assembly and front plate, if wear exceeds .0015, housing assembly or front plate should be replaced.

REASSEMBLY

1. Snap ring (10), back-up washer (9), shaft seal (8) and o-ring (6) should be replaced as new parts.
2. Install o-ring (6) in groove of front plate (7).
3. Dip gear assemblies (3 & 4) into oil and slip into front plate bushing.
4. Install housing assembly (1) noting position of scribe line. Install cap screws, draw up bolts evenly and torque to 22-25 ft. lbs.
5. Oil shaft seal (8) liberally. Work shaft seal (8) over drive shaft taking care not to cut rubber sealing lip.
6. Seat shaft seal (8) by tapping with plastic hammer. Install new back-up washer (9), and snap ring (10).
7. Replace key (5) in drive shaft (4).

PLACING MOTOR BACK INTO OPERATION

When placing a rebuilt motor back into operation, it is important to follow the break-in procedure to prevent damaging the motor. If at all possible, run the motor at operating R.P.M. for 10 minutes with the motor disconnected from the machine. If the motor cannot be run without being connected to the machine, make all the necessary connections and run motor at operating R.P.M. for 10 minutes at minimal load. Increase the load

on the motor and run for 3 minutes at operating R.P.M. Place full load on motor and run for 3 minutes at operating R.P.M. Idle engine and inspect for external leaks and check to be sure that all connections are tight. NOTE: If dual rotation motor, run in both directions during break in procedure. The motor is now ready to be placed back into service.

TROUBLE SHOOTING

POSSIBLE MOTOR TROUBLE	CAUSES	REMEDIES
1. Erratic motor R.P.M.	<ul style="list-style-type: none"> a. Oil supply low. b. Oil too heavy. c. Oil filter plugged. 	<ul style="list-style-type: none"> a. Fill reservoir. b. Change to proper viscosity. c. Clean filters.
2. Oil heating	<ul style="list-style-type: none"> a. Oil supply low. b. Contaminated oil. c. Setting of relief valve too high or too low. d. Oil in system too light. 	<ul style="list-style-type: none"> a. Fill reservoir. b. Drain reservoir and refill with clean oil. c. Set to correct pressure. d. Drain reservoir and refill with proper viscosity oil.
3. Shaft seal leakage.	<ul style="list-style-type: none"> a. Worn shaft seal. b. Bushings out of position. c. Excessive internal wear. 	<ul style="list-style-type: none"> a. Replace shaft seal. b. and c. If replacing the shaft seal does not stop leakage, the motor should be disassembled and checked for items b., c.
4. Foaming oil.	<ul style="list-style-type: none"> a. Low oil level. b. Air leaking into suction line of pump. c. Wrong kind of oil. 	<ul style="list-style-type: none"> a. Fill reservoir. b. Tighten fittings. c. Drain and fill reservoir with non-foaming oil.

TORO Part No. 58-5650

Steering Pump

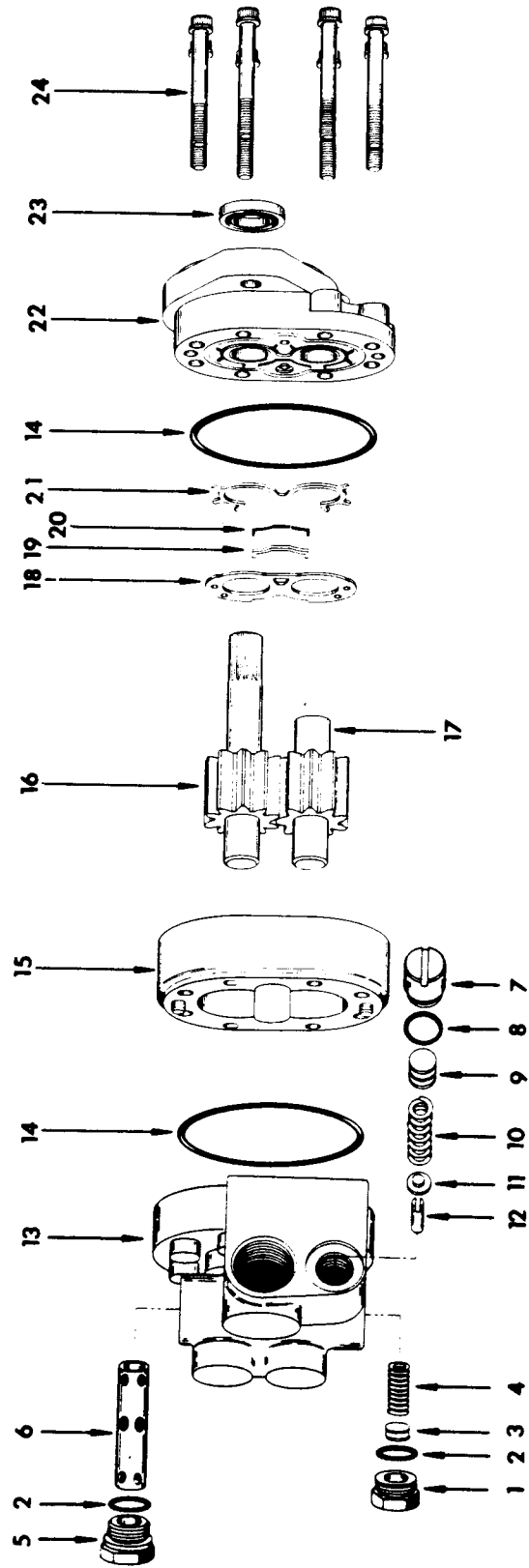

SERVICE INSTRUCTIONS
FOR THE
GEAR PUMP ASSEMBLY WITH FLOW DIVIDER

DISASSEMBLY

1. Thoroughly clean outside of pump.
2. Use sharp tool to mark across front plate, body and backplate. This will assure proper reassembly.
3. Use slotted socket and remove relief valve plug (7), shims (9), spring (10), plug seat (11) and seat (12) from backplate (13). NOTE: Do not remove internal relief valve cartridge assembly. Cartridge assembly has been set to a predetermined depth with locktite applied.
4. Remove plug (5), spool (6), plug (1), shims (3) and spring (4) from backplate (13).
5. Clamp pump in vise, shaft up.
6. Remove cap screws (24), eight each.
7. Remove pump from vise, hold pump in hands and bump shaft against wooden block to separate front plate (22) from backplate (13). Body will remain with either front plate or backplate.
8. Remove wear plate (18) from body gear pockets.
9. Remove drive gear assembly (16) and idler gear assembly (17) from body.
10. To separate body (15) from the plate it remains with, place drive gear assembly (16) in bushing and tap protruding end with plastic hammer or rawhide mallet.
11. Remove o-ring (14) from front plate (22) and back plate (13).
12. Remove back-up gasket (21) from front plate (22) by prying with a sharp tool.
13. Remove bearing seal (19) from front plate (22) by prying with a sharp tool.
14. Remove molded o-ring (20) from front plate (22).
15. Remove shaft seal (23) from front plate (22) by prying with a screwdriver.

INSPECTION

GENERAL

1. Clean and dry all parts.
2. Remove all nicks and burrs from all parts with emery cloth.

GEAR ASSEMBLY

1. Check drive shaft spline for twisted or broken teeth or check keyed drive shaft for broken or chipped keyway.
2. Inspect both the drive gear and idler gear shafts at bushing points and seal area for rough surfaces and excessive wear.
3. If shaft measures less than .748 in bushing area, the gear assembly should be replaced. (One gear assembly may be replaced separately; shafts and gears are available as assemblies only.)
4. Inspect gear face for scoring and excessive wear.
5. If gear width is below .510 - the gear assembly should be replaced.
6. Be sure snap rings are in grooves on either side of drive and idler gears.
7. If edge of gear teeth are sharp, break edge with emery cloth.

FRONT AND BACKPLATE

1. Oil groove in bushings in both front plate and back plate should be in line with dowel pin holes and 180° apart. This positions the oil grooves closest to respective dowel pin holes.
2. If I.D. of bushings in front plate or back plate exceed .755 front or backplate should be replaced. (Bushings are not available as separate items.)
3. Bushings in front plate should be flush with face of front plate.
4. Inspect backplate spool bore for scoring or contamination.
5. Inspect spool O.D. for scratches. It should be smooth and free of nicks and burrs. Spool should slide freely inside back plate bore.
6. Check shims for wear.
7. Check springs for weakness or breakage.
8. Wash back plate in clean solvent, direct compressed air into relief valve cavity in back plate to dry relief valve cartridge assembly. The procedure removes any trapped contamination.

BODY

1. Check inside gear pockets for excessive scoring or wear.
2. Body should be replaced if I.D. of gear pockets exceeds 1.713.

GENERAL INFORMATION

It is important that the relationship of the back plate, body, wear plate and front plate is correct. You will note two half moon cavities in the body which must face away from the front plate. Note: The smaller half moon port cavity must be on the pressure side of the pump. Side of wear plate with mid section cut out must be on suction side of pump. Suction side of backplate is always side with larger port boss.

REASSEMBLY

1. Wear plate, bearing seal, molded o-ring, back-up gasket, shaft seal and o-rings should be replaced as new parts.
2. Install o-ring (14) in groove of front plate (22).
3. Tuck back-up gasket (21) into groove in front plate (22) with open part of "V" section down.
4. Place molded o-ring (20) in groove in front plate. Place bearing seal (19) over molded o-ring, groove side down.
5. Apply a thin coat of heavy grease to both milled faces of body. Slip body onto front plate, half moon port cavities in body must face away from front plate.
6. Place wear plate (18) on top of back-up gasket with bronze face up. The side with the mid section cut away must be on suction side of pump.
7. Dip gear assemblies into oil and slip into front plate bushings.
8. Install o-ring (14) in groove in back plate (13).
9. Slide back plate (13) over gear shafts until dowel pins are engaged.
10. Install cap screws (24). Tighten evenly to 25/28 ft. lbs. torque.
11. Liberally oil shaft seal (23) and carefully work over drive shaft being careful not to cut rubber sealing lip.
12. Place 1-5/16" O.D. sleeve over shaft and press in shaft seal (23) until flush with front surface of front plate.

13. Install relief valve parts in backplate (13); seat (12), plug seat (11) spring (10), same number of shims (9) and torque plug to $2\frac{1}{24}$ ft. lbs.
14. Install flow divider parts in back plate (13), spool (6), spring (4), same number of shims (3), new o-rings (2) on plugs (1 & 5) and torque to $2\frac{1}{24}$ ft. lbs.

SINGLE OR DOUBLE PUMP TROUBLE SHOOTING

PUMP TROUBLE	PROBABLE CAUSE	REMEDY
1. Noisy pump caused by cavitation.	a. Oil too heavy. b. Oil filter plugged. c. Suction line plugged or too small.	a. Change to proper viscosity. b. Clean filters. c. Clean line and check for size.
2. Oil heating	a. Oil supply low. b. Contaminated oil. c. Setting of relief valve too high or too low. d. Oil in system too light.	a. Fill reservoir. b. Drain reservoir and refill with clean oil. c. Set to correct pressure. d. Drain reservoir and refill with proper viscosity oil.
3. Shaft seal leakage	a. Worn shaft seal. b. Worn shaft in seal area c. Broken bearing seal or back-up gasket d. Bushings out of position. e. Excessive internal wear.	a. Replace shaft seal. b. Replace drive shaft c. If replacing the shaft and shaft seal does not stop seal leakage, the pump should be disassembled and checked for items 3, c. & d. d. Disassemble pump and replace front plate. e. Disassemble pump inspect parts and replace as needed.
4. Foaming oil	a. Low oil level. b. Air leaking into suction line. c. Wrong kind of oil.	a. Fill reservoir. b. Tighten fittings. c. Drain and fill reservoir with non-foaming oil.

PLACING PUMP BACK INTO SERVICE

1. If shop test stand is available, the following procedure for testing rebuilt pumps is recommended:

- A. Mount pump on test stand making sure that the proper level of clean oil is available in the reservoir. Check suction line for leaks and obstructions.
- B. Start pump and run for three minutes at zero pressure.
- C. Intermittently load pump to 500 P.S.I. for three minutes.
- D. Intermittently load pump to 1000 P.S.I. for three minutes.
- E. Intermittently load pump to 2000 P.S.I. for

three minutes.

F. Remove pump from test stand and check for freeness of drive shaft. Check for leaks.

2. If shop test stand is not available, the following procedure for testing rebuilt pumps is recommended:

- A. Mount pump on equipment and run pump at 1/2 engine speed at zero pressure.
- B. By operating control valve build pressure intermittently for three minutes.
- C. Increase engine speed to full throttle and build pressure intermittently for three minutes.
- D. Idle engine and check for leaks.

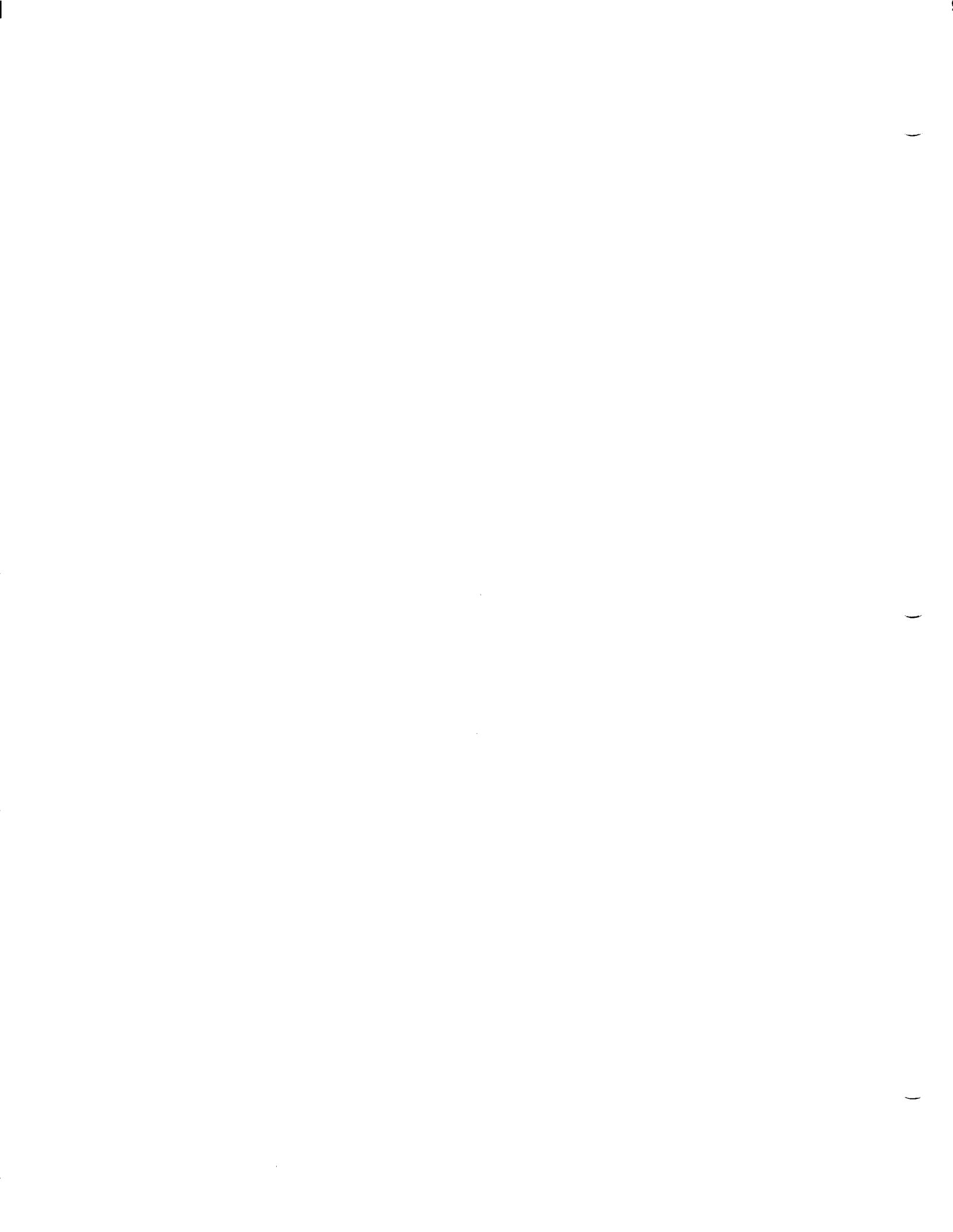

TORO Part No. 58-5470

Lift Control Valve

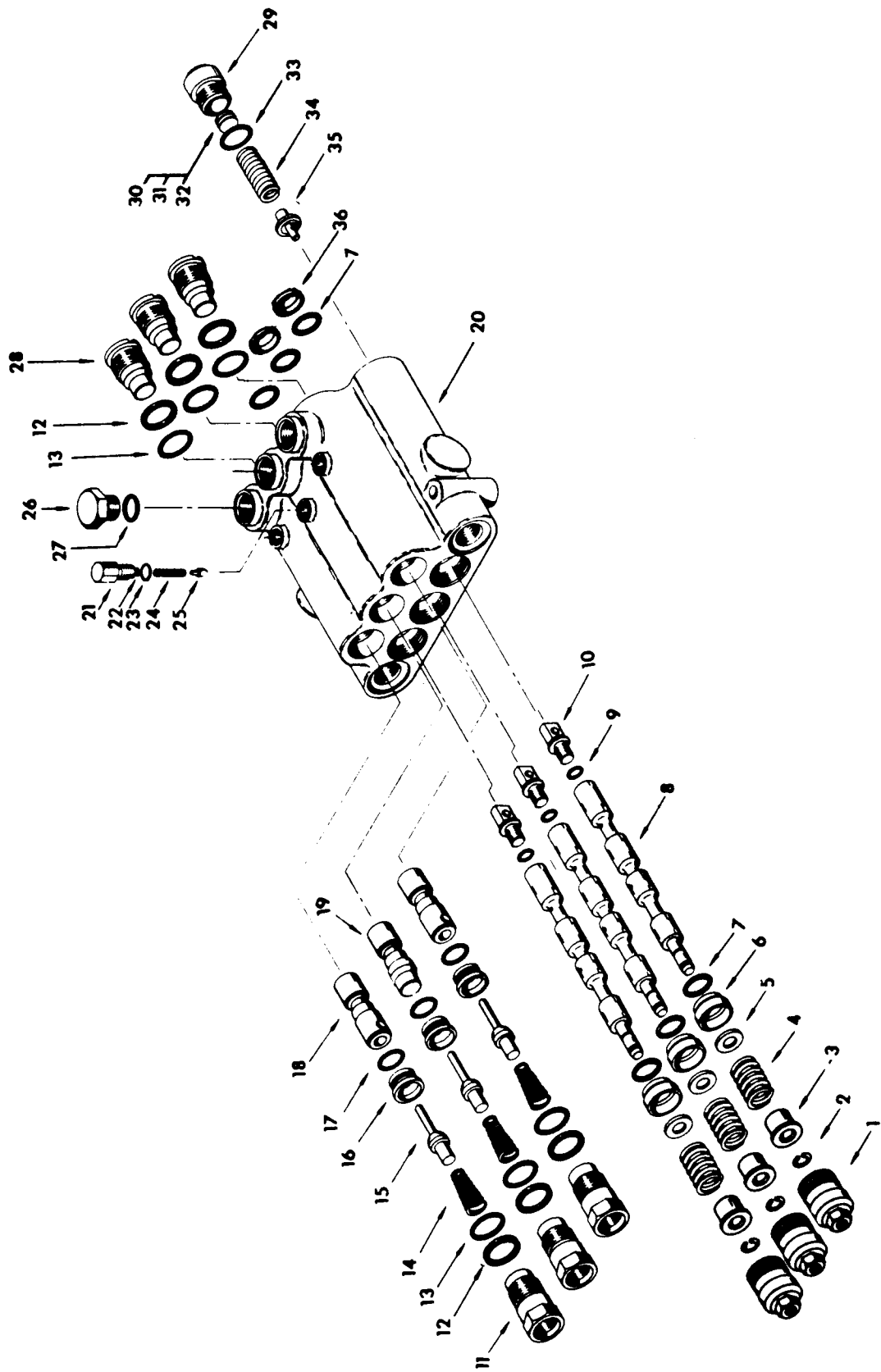

SERVICE INSTRUCTIONS
FOR THE
CONTROL VALVE ASSEMBLY

DISASSEMBLY

1. Plug all ports and clean outside of valve thoroughly.
2. Remove spool caps (1).
3. Do not remove retaining rings (2) from spools (8)
4. Remove spools (8) from valve body (20) NOTE: Spools and spool bores are a matched set. Be sure each spool is identified with the correct body spool bore.
5. Remove bushings (3) and o-rings (7) from spools.
6. Remove clevis (10) and o-ring (9) from spools (8). (Clevis need not be removed unless spool is leaking.)
7. Remove lockout plugs (28) and port adapter plugs (11) from valve body.
8. Remove plungers (18 & 19). CAUTION: Check location and position of plungers when removing from body to assure proper reassembly.
9. Remove relief valve plug (29), shims (30, 31, 32), spring (34) and poppet (35) from body. NOTE: Do not remove poppet seat. Seat has been set to a predetermined depth and locked in place.
10. Remove wiper seals (36) and o-rings (7) from body spool bores.
11. Remove plug (26).
12. Remove detent plunger plug (21), detent spring (24) and detent plunger (25). Remove discs (22) from plug.
13. Remove all o-rings and back-up washers from all plugs and seats.

INSPECTION

1. Remove all nicks and burrs from parts and inspect for excessive wear.
2. Inspect all plungers and poppet seats for burrs or roughness.
3. Inspect spool springs (4), relief valve spring (34), lockout springs (14) and detent spring (24) for breakage.
4. If spools have excessive wear, the valve becomes non-serviceable as the spools and spool bores are matched and damaged spools cannot be replaced.

5. Inspect relief valve poppet (35) for breakage or wear.
6. Inspection of o-rings, back-up washers and nylon poppets and wiper seals is not necessary. It is recommended that they be replaced as new parts when the valve is serviced.

SERVICE OF RELIEF VALVE

The pin type relief valve is serviced when disassembly of the valve is accomplished. If a higher or lower system pressure is required, shims (30, 31, 32) may be added or taken out as needed. The thickness of the shims are .010, .015 and .035

REASSEMBLY

1. Thoroughly clean and dry all parts. Metal parts should be lightly oiled prior to assembly. NOTE: All o-rings, back-up washers and nylon poppets should be replaced as new items.
2. Position new o-rings (7) in proper grooves in spool bores.
3. Install relief valve components (35, 34, 30, 31, 32) and new o-ring (33) on plug (29).
4. Install plungers (18 & 19). NOTE: Check location and positioning of plungers during installation.
5. Install seats (16), poppets (15), springs (14), port adapter plugs (11) into valve body.
6. Install plugs (26) with new o-rings (27).
7. Install detent plunger (25), detent spring (24) disc (22) and detent plunger plug (21) with new o-ring (23) and torque to 20-30 in. lbs.
8. If clevis (10) had been removed, install with new o-ring (9) in spools (8).
9. Slide bushings (6) over spools, slide new o-ring (7) over spool and position next to bushing (6). Dip spools in oil and install spool assemblies (8) in proper location.
10. Install spool caps (1) into proper location in valve body and torque to 20-25 ft. lbs.
11. Install lockout plugs (28) with new backup washers (12) and o-rings (13).

TROUBLE SHOOTING

TROUBLE	PROBABLE CAUSE	REMEDY
1. Low system pressure.	<ul style="list-style-type: none"> A. Worn poppet. B. Weak or broken spring. 	<ul style="list-style-type: none"> A. Replace worn poppet. B. Add shims or replace spring.
2. Sticky valve spool.	<ul style="list-style-type: none"> A. Misaligned control linkage. B. Foreign matter in spool bore. C. Incorrect mounting bolt torque. 	<ul style="list-style-type: none"> A. Correct alignment. B. Remove spool and clean bore. C. Retorque mounting bolts to 12-15 ft. lbs.
3. External leakage.	<ul style="list-style-type: none"> A. Damaged o-rings. 	<ul style="list-style-type: none"> A. Disassemble valve and replace o-rings.
4. Load drops with spool in centered position.	<ul style="list-style-type: none"> A. Damaged cylinder packing. B. Line to cylinder leaking. C. Damaged o-rings on lockout plugs or seats. D. Damaged or worn lockout poppet assembly. E. Broken lockout spring. 	<ul style="list-style-type: none"> A. Replace cylinder packing. B. Tighten fittings or replace line. C. Remove lockout plugs or seat and replace o-rings. D. Replace lockout poppet assembly. E. Replace lockout spring.
5. Electrical function does not operate when spool with micro switch is operated.	<ul style="list-style-type: none"> A. Damaged micro switch. B. Broken or lose electrical connection. C. Micro switch out of adjustment. 	<ul style="list-style-type: none"> A. Replace micro switch. B. Check all electrical connections. C. Readjust micro switch.

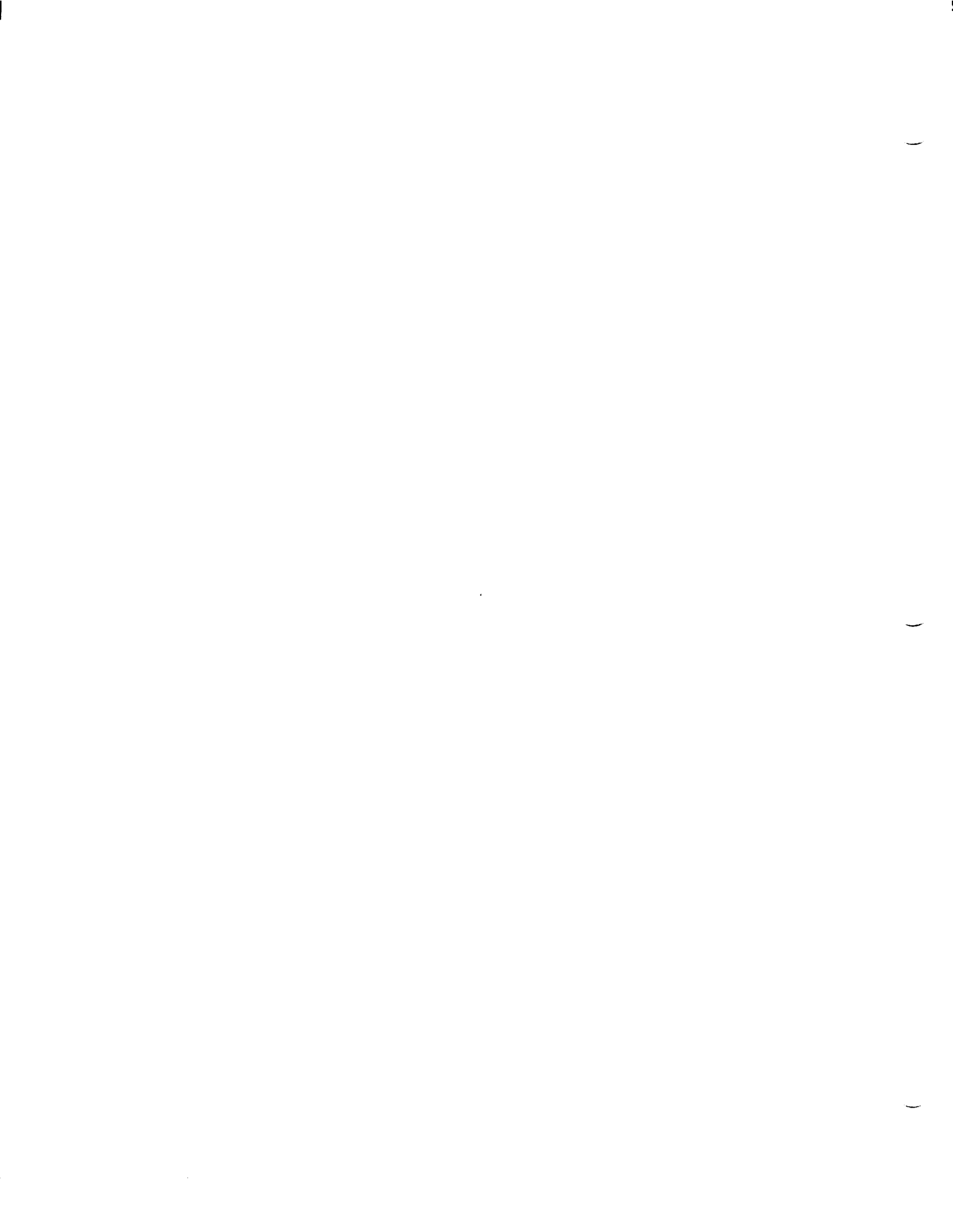

TORO Part No. 58-5490
Priority Flow Divider

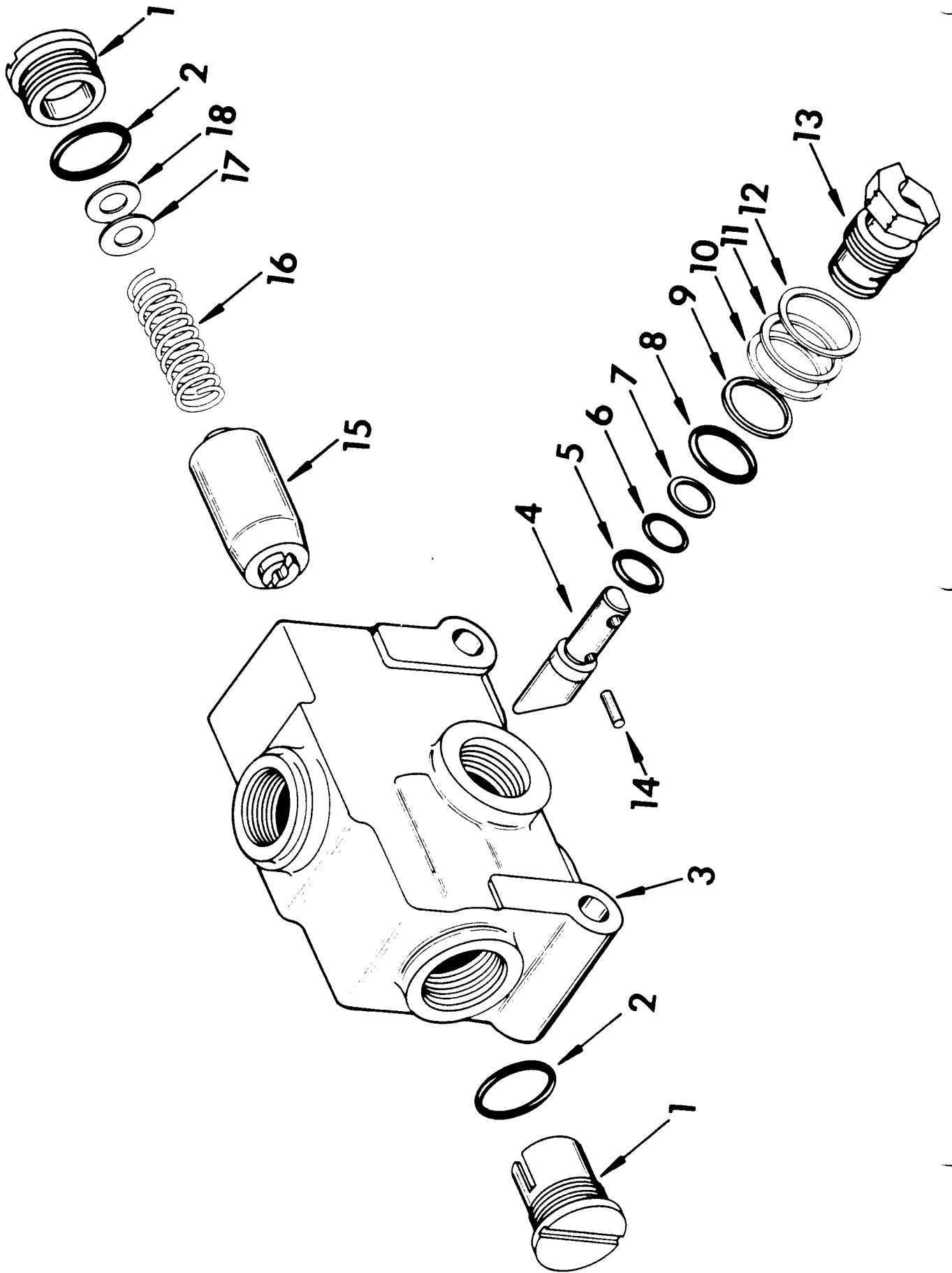

SERVICE INSTRUCTIONS
FOR THE
VARIABLE PRIORITY FLOW DIVIDER

DISASSEMBLY

1. Plug all ports and thoroughly clean outside of valve.
2. Remove plug (1) from body (3).
3. Remove plug (1), shims (18 & 17), spring (16) and flow control spool (15) from body (3).

NOTE: Notice the position of the spool in relation to valve body when removing spool (15).

4. Remove metering plug (13).
5. Remove shims (10, 11 & 12) from metering plug (13).
6. Remove o-rings (5 & 8) and back-up washer (9) from metering plug (13).
7. Remove roll pin (14) and remove screw body (4) from metering plug (13).
8. Remove o-ring (6) and back-up washer (7) from inside metering screw (13).

INSPECTION

1. Thoroughly clean and dry all parts.
2. Remove all nicks and burrs with emery cloth.
3. Inspect the spool bore inside the body, the surface should be smooth and free of deep score marks.
4. Inspect O.D. of spool, it should be smooth and free of nicks and burrs. Spool should slide freely inside the body bore.
5. Inspect surface of screw body (4) for deep scratches and burrs.

REASSEMBLY

1. Install new back-up washer (7) inside metering plug (13).
2. Install new o-ring (6) inside metering plug (13).
3. Oil screw body (4) and install in metering plug (13). Secure with roll pin (14).

4. Install new back-up washer (9) and new o-rings (5 & 8) on metering plug (13).
5. Install shims (10, 11 & 12) on metering plug (13).
NOTE; Install the same number of shims that were removed.
6. Install metering plug assembly and tighten.
7. Install new o-ring (2) on plug (1) and install plug.
8. Install flow control spool (15), spring (16) shims (17 & 18).
NOTE: Install same number of shims as were removed.
9. Install new o-ring (2) and plug (1) and install plug.

TORO Part No. 58-5450

Lift Cylinder

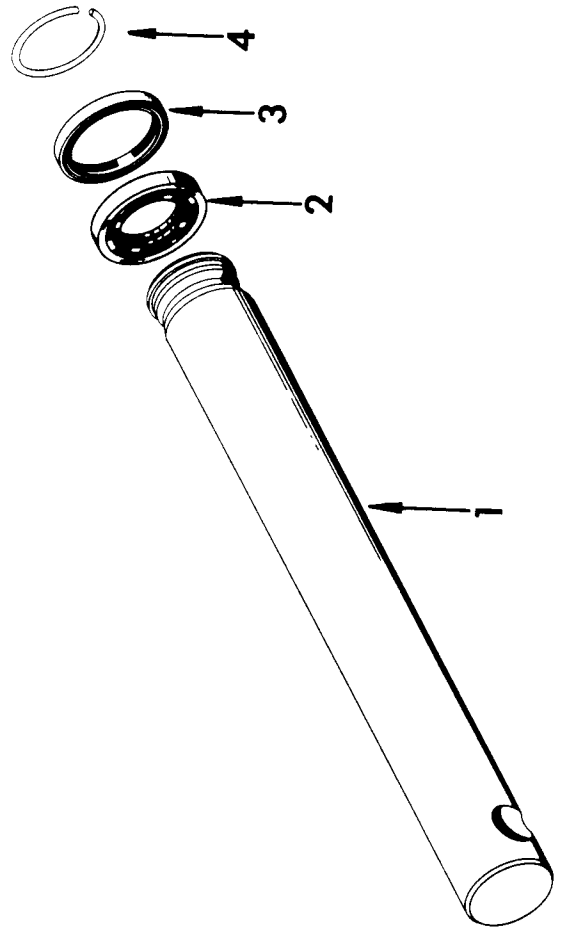
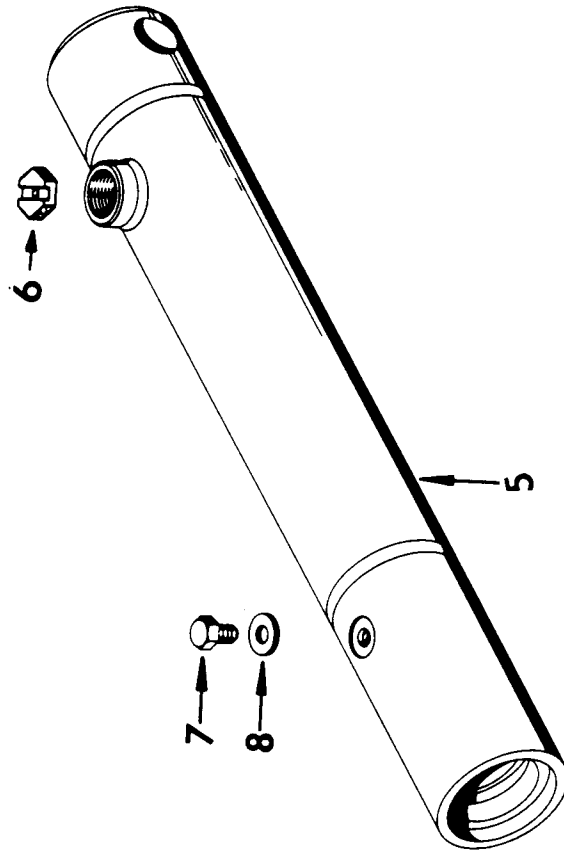

SERVICE INSTRUCTIONS
FOR THE
CYLINDER

DISASSEMBLY

1. Thoroughly clean outside of cylinder assembly.
2. Pull rod (1) out until end of rod and lock ring (4) can be seen through inlet port.
3. Insert screw driver in inlet port and slide lock ring (4) into deep groove in the rod assembly.
4. Remove rod assembly (1) from barrel assembly (5).
5. Remove wiper seal (2) and seal (3) from I.D. of barrel assembly.

INSPECTION

1. It is not necessary to inspect seals (2 & 3) or lock ring (4). These parts should be replaced as new items and are included in the seal repair kit available for this cylinder.
2. Thoroughly clean all parts and remove all nicks and burrs with emery cloth.
3. Inspect I.D. of barrel assembly (5) for excessive wear or scoring.
4. Inspect O.D. of rod (1) for nicks, scratches or scoring.

REASSEMBLY

1. All parts should be cleaned and dried thoroughly. Metal parts should be lightly oiled prior to reassembly.
2. Install new seal (3) in barrel. Install new wiper seal (2) in barrel with lips facing outward.
3. Install new lock ring (4) in deep groove of rod end (1).
4. Oil outside of piston rod (1) and carefully insert rod in barrel assembly (5).
5. Push rod into barrel assembly until lock ring area of rod can be seen through port.
6. By using screw driver through port, pop lock ring into lock position.

7. Extend rod to full out position to make sure lock ring is locked.
8. Cycle cylinder and check for leaks.

TORO Part No. 58-5480
Reel Control Valve

PARTS IDENTIFICATION

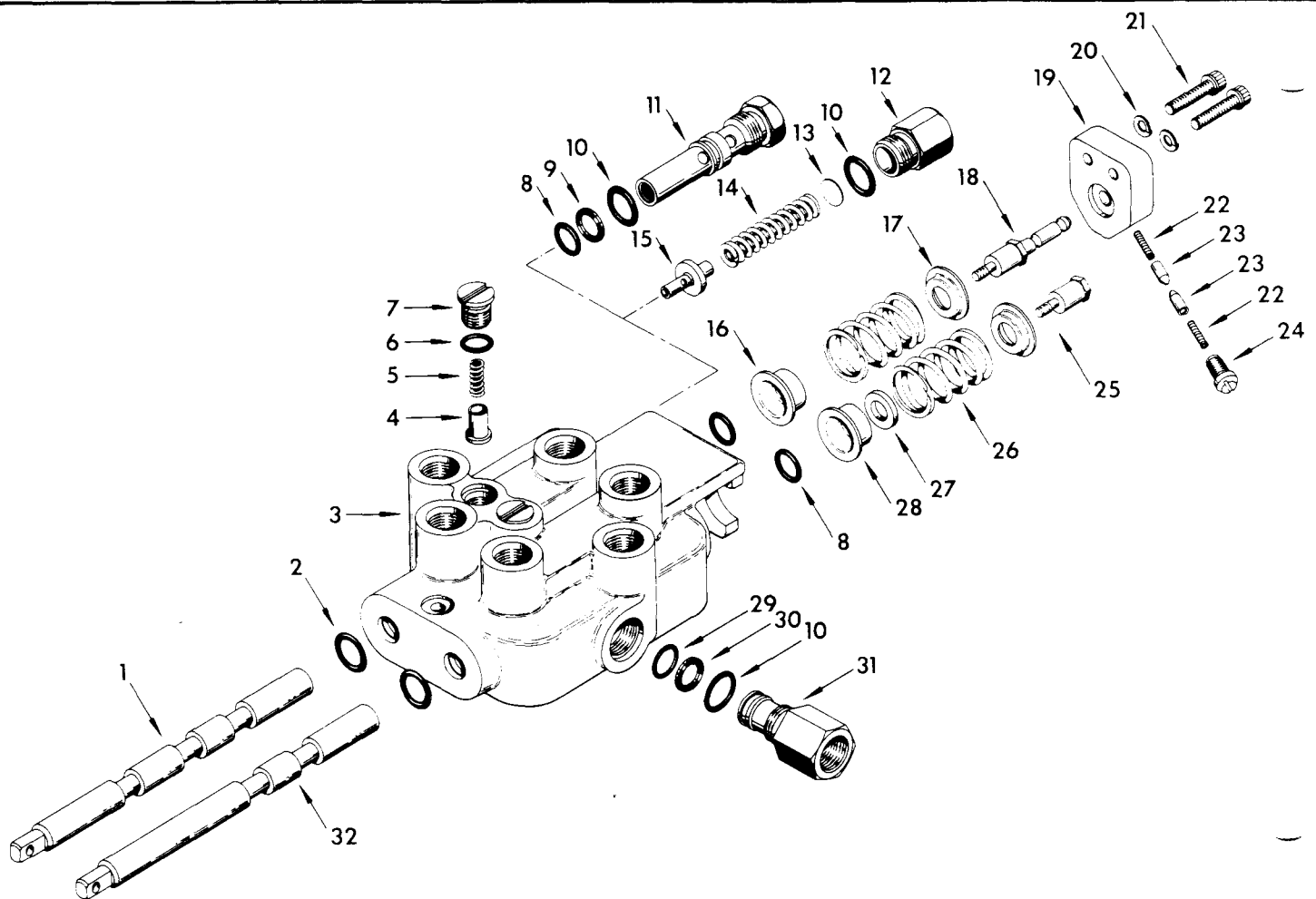

PARTS LIST

REFERENCE NUMBER	DESCRIPTION
1	Spool
2	O-ring, 1/8 x 5/8 I.D.
3	Body and Seat Assembly
4	Plunger, Lift Check
5	Spring, Lift Check
6	O-ring, 3/32 x 1/2 I.D.
7	Plug, Lift Check
8	O-ring, 3/32 x 5/8 I.D.
9	Back-up Washer, 3/32 x 5/8 I.D.
10	O-ring, 3/32 x 3/4 I.D.
11	Relief Valve, Cartridge Type
12	Cap, Relief Valve
13	Shim, Relief Valve
14	Spring, Relief Valve
15	Pin Assembly, Relief Valve
16	Washer, Deep

REFERENCE NUMBER	DESCRIPTION
17	Washer, Shallow
18	Screw, Spool Detent
19	Block, Detent
20	Lock Washer, 1/4 x .062
21	Cap. Scw. 1/4-20 Skt. HD 1" Lg.
22	Spring, Detent Pawl
23	Detent Pawls
24	Detent Pawl Plug
25	Clip Ring, 1/2" Shaft
26	Spring, Spool
27	Spacer
28	Washer, Deep
29	O-ring, 1/16 x 5/8 I.D.
30	Back-up Washer, 5/8 I.D.
31	Plug, Pressure Beyond
32	Spool

INSTRUCTIONS

DISASSEMBLY

1. Plug all outlets and thoroughly clean outside of valve.
2. Remove lift check plugs (7), springs (5) and lift check plungers (4).
3. Remove relief valve components (12, 10, 13, 14 & 15) or (8, 9, 10 & 11).
4. Mark spools and body position of each spool.
NOTE: Spools and bodies are matched sets. Be sure each spool is identified with the correct body bore.
5. Detent Spool
 - a. Remove screws (21) and lock washers (20). Remove detent block (19) and remove detent pawl plug (24), spring (22), detent pawls (23) from detent block.
 - b. Remove detent screw (18), and remove washer (17), spring (26) and washer (16).
Remove spool (1).
6. Standard Spool
 - a. Remove spool screw (25), washer (17), spring (26), spacer (27) and washer (28).
Remove spool (32).
7. Remove pressure beyond plug (31), o-ring (10), back-up washer (30) and o-ring (29).
8. Remove all o-rings and back-up washers from all plugs, relief valves and body bore.
9. Thoroughly clean all parts.

INSPECTION

1. Remove nicks and burrs from all parts.
2. Inspect spools and body bore for excessive wear.
NOTE: If internal leakage with the spools in spring centered position has been experienced, wear is indicated between the spool and body bore. This can be corrected by replacing the spools and body as an assembly. Spools or bodies cannot be serviced separately.
3. Inspect relief valve. See "Service of Relief Valves" section of this manual.
4. Inspection of o-rings and back-up washers is not necessary. It is recommended that these be replaced as new parts.
5. Inspect lift check seats in body for wear.

SERVICE OF RELIEF VALVES

CARTRIDGE TYPE

The pilot operated cartridge type relief valve is not adjustable and is pre-set at the factory. However, to insure cleanliness in the system, snap ring, washer, and screens may be removed, cleaned with air and replaced.

PIN TYPE

The pin type relief valve shown in the exploded view as items (12, 10, 13, 14 and 15) is serviced when disassembly of the valve is accomplished. If a higher or lower system pressure is required, shims (13) may be added or taken out as needed.

REASSEMBLY

1. Thoroughly clean and dry all parts. Metal parts should be lightly oiled prior to assembly.
NOTE: All o-rings and back-up washers should be replaced as new parts.
2. Position o-rings (2) and (8) in body bore.
3. Install o-rings and back-up washers on relief valve and plugs.
4. Insert plunger (4) and spring (5) into lift check seat.
5. Install lift check plugs (7).
6. Detent Spool
 - a. Install washer (16), spring (26) and washer (17) into proper position in body casting. Insert spool (1) into body bore and screw detent screw (18) into spool.
 - b. Install detent spring (22), detent pawls (23), spring (22) and detent pawl plug (24) into detent block (19). Slip detent block (19) over detent screw (18) and secure to valve body (3) with lock washer (20) and cap screws (21).
7. Standard Spool
 - a. Install washer (28), spacer (27), spring (26) and washer (17) into proper position in body casting. Insert spool (32) into body bore and secure with spool screw (25).
8. Install relief valve.
9. Install pressure beyond plug assembly (31).
10. Run operational check.

TROUBLE SHOOTING

TROUBLE	PROBABLE CAUSE	REMEDY
1. Low system pressure.	a. Dirty relief valve screen or plugged orifice plate. b. Worn or stuck relief valve.	a. Remove and clean. b. Remove valve and replace with new assembly or add shims to pin type relief valve.
2. Sticky valve spool.	a. Misaligned control linkage. b. Foreign matter in spool bore.	a. Correct alignment. b. Remove spool and clean bore.
3. External leakage.	a. Damaged o-rings.	a. Disassemble valve and replace o-rings.
4. Work load lowers with spool in "slow-raise" position.	a. Damaged lift check plunger. b. Damaged lift check seat in body. c. Damaged o-ring on lift check plug.	a. Replace lift check plunger. b. Replace spool and body assembly. c. Replace o-ring.
5. Load drops with spool in centered position.	a. Damaged cylinder packing. b. Line to cylinder leaking. c. Scratched spool or body bore.	a. Replace cylinder packing. b. Tighten fittings or replace hose. c. Replace control valve.

TORO Part No. 58-5460
Reel Shut Off Valve

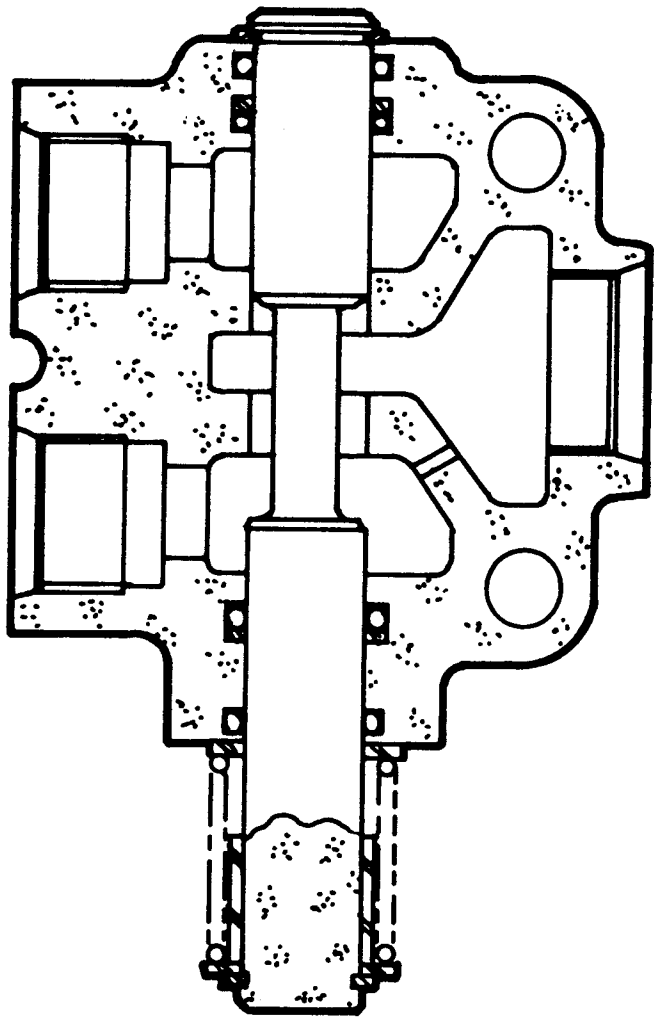

SERVICE INSTRUCTIONS
for the
Selector Valve

DISASSEMBLY

1. Thoroughly clean outside of valve.
2. Remove retaining ring from end of spool.
3. Remove spool from valve body.
4. Remove washers, spring and spacer from spool.
5. Remove o-rings and backup washers from spool bore.

INSPECTION

1. Thoroughly clean and dry all parts.
2. Inspect the spool bore inside the body. The surface should be smooth and free of deep scratches.
3. Inspect O.D. of spool, it should be smooth and free of nicks and burrs.
4. Inspect spring for breakage.

REASSEMBLY

1. Install new backup washers and o-rings in spool bore. (o-rings to the inside of the backup washer)
2. Install washer, sleeve, spring and second washer on spool end.
3. Dip spool in oil and slide in body bore taking care not to cut o-rings. Be sure spool is installed in the proper position.
4. Install retaining ring on end of spool.



TORO Part No. 58-5660

Traction Pump

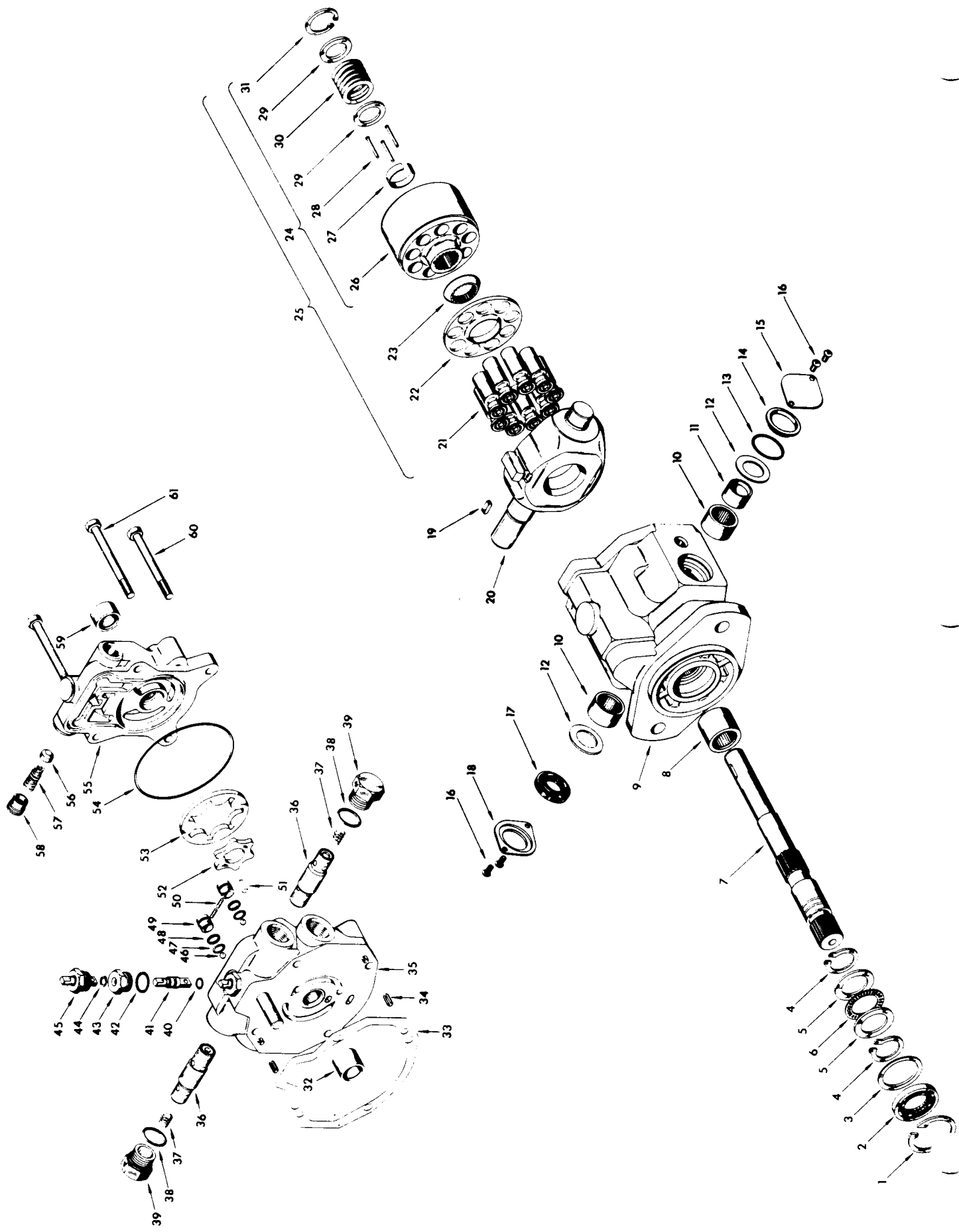

SERVICE INSTRUCTIONS
FOR THE
PISTON PUMP ASSEMBLY

DISASSEMBLY

1. Disconnect all control linkage, hydraulic lines and remove pump assembly from vehicle.
2. Plug all ports and thoroughly clean outside of pump.
3. Clamp the end of the drive shaft in a protected jaw vise with the body of the pump up and remove the four capscrews (61 & 60) from the adapter plate of the pump.
4. Use a plastic mallet and tap the adapter (55) to loosen it, then pull the adaptor straight up until it is free.
5. Remove spring retainer (58) and remove spring (57) and poppet (56) from adaptor assembly (55).
6. Remove the outer gerotor gear (53), inner gerotor gear (52) and key (51) from the pump shaft.
7. Remove the two check valve assemblies (49) from back plate. Pin (50) is loose fitting. Caution should be taken when removing check valve assembly so that pin (50) and ball (46) are not lost.
8. Use screw driver slots in housing and pry up on back plate (35) or tap with plastic mallet to loosen, then pull the back plate straight up to remove. Remove gasket (33).
9. Remove the tow valve (45) from back plate. To disassemble tow valve, remove snap ring (44) from spreader (41), and pull spreader from spreader plug (43).
10. Remove plug assembly (39), spring (37) and relief valve assembly (36) from back plate.
11. Remove pump from vise and remove rotating assembly (25) from pump housing.
12. If pistons (21) did not come out with piston block, you may remove them, spider(22), and spider pivot (23).
13. The piston block assembly (24) need not be disassembled unless the pins (28) or spring (30) is damaged.

CAUTION

The following procedure should be used if the spring is to be removed from the piston block. The spring (30) is highly compressed and the snap ring (31) should not be removed without compressing the spring (30).

The following parts will be needed to disassemble the piston block:

- 2 each 3/8 I.D. X 1-1/8 O.D. flat washers
- 1 each 3/8 X 3-1/4 N.C. cap screw
- 1 each 3/8 N.C. nut

Place one of the flat washers over the 3/8 X 3-1/4 cap screw and place this through the center of the piston block. Place the other washer over the cap screw and let it rest on the three pins. Screw the nut on and compress the spring inside the piston block. Use a pair of snap ring pliers and remove the internal snap ring. Remove the bolt and the two washers. Remove the washer (29), spring (30), washer (29), and three pins (28) and the internal pin keeper(27).

14. Remove snap ring (1) from housing. Press shaft (7) from housing (9) and remove shaft seal (2) and washer (3).
15. Remove snap ring (4) from shaft and remove thrust washers (5) and thrust bearing (6).
16. To remove the camplate (20) from housing, remove screws (16) from the sides of the housing. Remove two covers (15 & 18) o-ring cover (14), o-ring (13), washer (12) inner race (11) and needle bearing (10). Remove shaft seal (17), washer (12) and needle bearing (10).

INSPECTION

1. Inspect the charge pump relief valve seat inside the charge pump adaptor. It should be smooth and free of burrs or other defects.
2. Inspect the charge pump relief valve poppet (56) and spring (57).
3. Inspect the gerotor pocket inside the charge pump adaptor housing (55). It should not be scored excessively.
4. Inspect the needle bearing (59) inside the charge pump adaptor housing, if the needles are free of excessive play and remain in the bearing cage there is no need to replace the bearing.
5. Inspect the check valve assembly (49), make sure the ball seat is in good condition and the ball is free to move.
6. Inspect the flat surfaces of the back plate (35), the finish on the gerotor side should show no galled surface. The finish on the piston block side should be smooth and free of grooves. The back plate should be replaced if it shows any of the wear characteristics outlined above. The cam stop should be tight in the back plate.
7. Inspect the piston block (26). The surface that contacts the back plate should be smooth and free of grooves.
8. The pistons (21) should move freely in the piston block bore. If they are sticky in the bore, examine the bore for scoring or contamination.

9. Examine the O.D. of the pistons for finish condition, they should not show wear or deep scratches. The shoes should be snug fit on the ball end of the pistons. The flat surfaces of the shoes should be flat and smooth. DO NOT LAP THE PISTON SHOES.
10. Examine the spider (22). It should be flat, no cracks and no signs of wear in the pivot area.
11. Examine the pivot (23). It should be smooth and show no signs of wear.
12. The camplate (20) should be inspected for the condition of the finish of the polished shoe surface. It should show no signs of scoring.
13. Inspect the shaft (7) for fretting in the bearing and spline areas.
14. Inspect thrust bearing (6) and washers (5) for wear.
15. Inspect the needle bearing (8) in the housing assembly. If the needles are free of excessive play and remain in the bearing cage, there is no need to replace the bearing.

REASSEMBLY

1. Clean all parts in suitable solvent, lubricate all critical moving parts before reassembly. If necessary, install new needle bearings in the housing. The camplate pivot bearings are slip fit; the shaft bearing (8) is press fit, install with numbered end of the bearing outward.
2. Insert camplate into housing. Insert the needle bearings (10) over the arm and slide into the housing.
3. Install washers (12) and shaft seal (17) over cam pivot bearing. Install seal cover (18) and secure with screws (16).
4. On the opposite side of housing install bearing (10), inner race (11) with chamfered I.D. inward, washer (12), o-ring (13), and o-ring cover (14) and secure with trunnion cover (15) and screws (16).
5. Install snap ring (4) on shaft (7). Install thrust washer (5), thrust bearing (6), and second thrust washer (5), secure with second snap ring (4).
6. Install shaft in housing and install washer (3), shaft seal (2), and retain with snap ring (1).
7. To reassemble piston block assembly, compress the pin keeper (27) and install in the spline of piston block. Install the three pins (28) with head end of pins to the inside of the block and install in the special grooves of the piston block spline.

8. Install the washer (29), spring (30), and second washer (29) in the piston block. Use the two 3/8 I.D. washers and the 3/8 X 3-1/4 cap screw to compress the spring and retain with snap ring (31). Remove the 3/8 X 3-1/4 cap screw and the two washers.
9. Install the pivot (23), spider (22) and the piston assemblies (21) in the piston block. Install rotating assembly (24) in the housing assembly, the piston shoes must be in contact with the camplate. Be sure all the parts are in their proper position.
10. Clamp pump assembly in a protected jaw vise with the open end of the housing up.
11. Install new gasket (33).
12. Install back plate (35).
13. Install ball (46) and pin (50) into check valve housing if removed. Install new o-ring (47) and back-up washer (48) on check valve assembly (49). Install o-ring nearest pin. Install in back plate (35) with pin in back plate.
14. Install key (51) on shaft and install inner gerotor gear (52) over shaft.
15. Install outer gerotor gear (53) over inner gerotor gear (52).
16. Install new o-ring (54) in groove in adaptor (55), hold in place with clean clear grease. Assemble adaptor on pump back plate. Retain with four cap screws (60 & 61) and torque to 27/31 ft. lbs.
17. Install new o-ring (40 & 42). Insert spreader (41) into separator plug (43) retain with snap ring (44).
18. Install tow valve assembly (45) in back plate (35) and torque 27/30 ft. lbs.
19. Install relief valve assemblies (36) in back plate.
20. Install new o-ring (38) and spring (37) on plug (39). Install plugs (39) in back plate and torque 55/60 ft. lbs.
21. Remove pump from vise and install poppet (56), spring (57), and spring retainer (58).

START-UP PROCEDURE

When initially starting a new or a rebuilt propulsion system, it is extremely important that the start-up procedure be followed. It prevents the chance of damaging the unit which might occur if the system was not properly purged with oil before start-up.

1. After the propulsion components have been properly installed onto the machine, fill the pump housing at least half full with an approved oil that has been filtered through a 10 micron filter. Connect all hydraulic lines and check to be sure that they are tight.
 2. Install and adjust all control linkage.
 3. Fill the reservoir with an approved oil that has been filtered through a 10 micron filter.
 4. Gasoline or L.P. engines: remove the coil wire and turn the engine over for 15 seconds. Diesel engines: shut off the fuel flow to the injector and turn the engine over for 15 seconds.
- This procedure enables the charge pump to pick up the oil before start-up.
5. Replace the coil wire or return the fuel flow to the injectors. Place the propulsion unit in the neutral position,

start the engine and run it at a low idle. The charge pump should immediately pick up oil and fill the system. If there is no indication of fill in 30 seconds, stop engine and determine the cause.

6. After the system starts to show signs of fill, slowly move pump camplate to a slight cam angle. Continue to operate system slowly with no load on motors until system responds fully.
7. Check fluid level in the reservoir and refill if necessary to the proper level with an approved oil that has been filtered through a 10 micron filter.
8. Check all line connections for leaks and tighten if necessary.
9. The machine is now ready to be put into operation.
10. Short hour filter changes are recommended for the first two changes after placing the machine back into operation. The first filter would be changed in 3-5 hours and the second at approximately 50 hours. Routine scheduled filter changes are recommended for maximum life of the hydraulic system.

TROUBLE SHOOTING

POSSIBLE TROUBLE	CAUSES	REMEDIES
1. System will not operate in either direction.	A. Oil supply low. B. Oil filter clogged. C. Oil too heavy. D. Control linkage misadjusted. E. Low charge pressure. F. Charge pump key sheared. G. Charge pump relief valve damaged. H. Charge pump gears worn or scored. I. Internal charge pump damage. J. Drive coupling broken. L. Relief valve stuck open. M. Damaged check valve.	A. Check oil level, fill. B. Replace filter element. C. Use proper viscosity oil. D. Check to see if control linkage is binding or unfastened. E. See below: F, G, H. & I. Pressure should be 60-100 P.S.I. F. Inspect charge pump for damage and replace key. G. Remove relief valve parts, examine parts and seat. Replace necessary parts. H. Remove parts and examine. Replace defective parts. If severe scoring is indicated, remove complete pump unit, disassemble, clean and inspect for damage. I. Disassemble pump, inspect for damage. J. Inspect coupling for sheared spline, key or broken chain. L. Remove relief valve, clean or replace. M. Disassemble and check if check valve is faulty or damaged.
2. System Noisy	A. Air in system. B. Loose suction line. C. Clogged suction filter. D. Internal pump or motor damage.	A. Low oil level in reservoir. B. Tighten fittings. C. Replace filter element. D. Disassemble, inspect and repair.
3. Sluggish response to acceleration or deceleration.	A. Air in system. B. Low charge pressure. C. Internal pump or motor wear or damage. D. Relief valve dirty or damaged.	A. See step 1-A, 1-B, 1-C, 2-B. B. See step 1-F, 1-G, 1-I. C. Disassemble, inspect and repair. D. Remove, clean or replace.



TORO Part No. 58-5430

Traction Motor

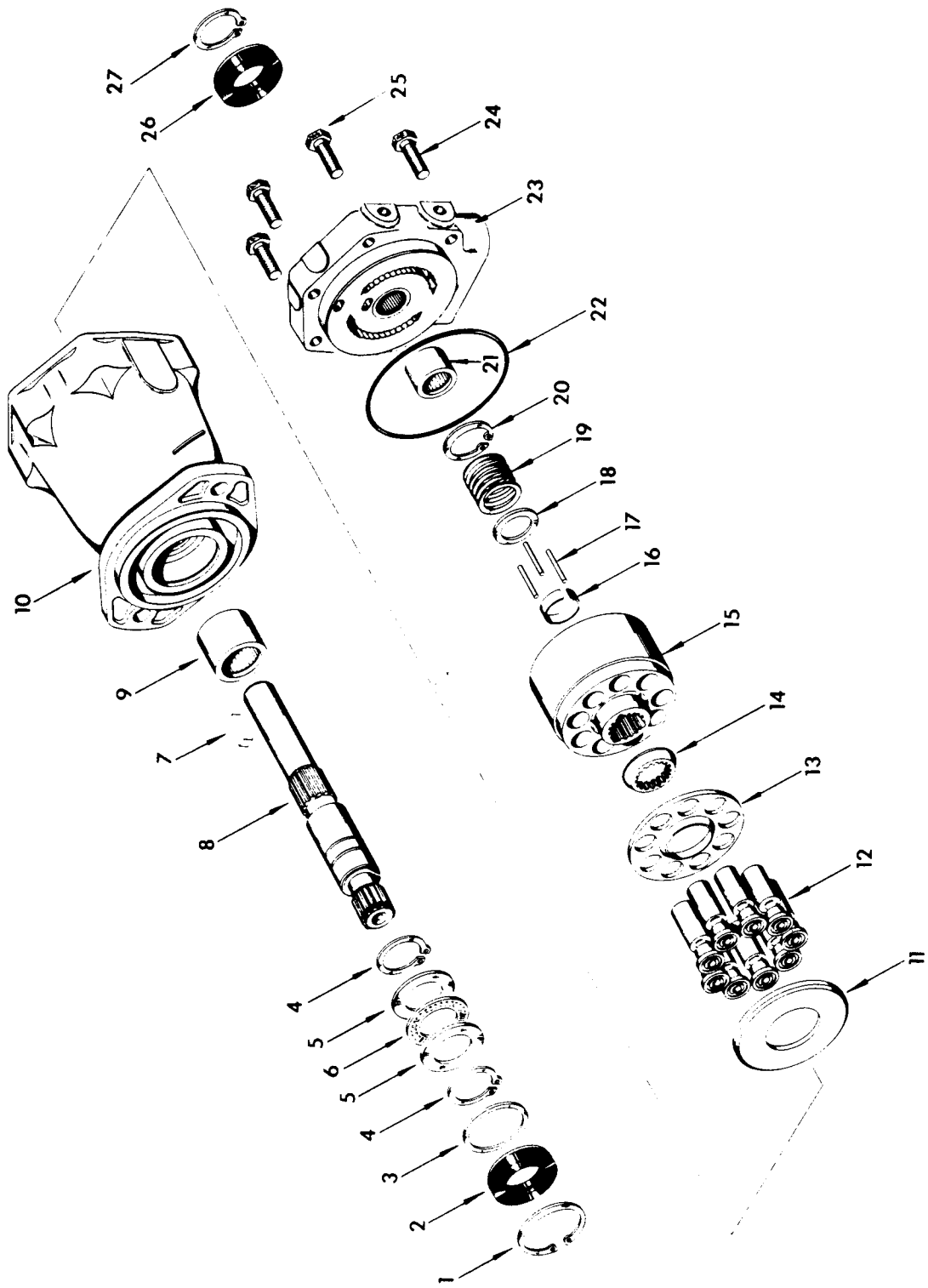

SERVICE INSTRUCTIONS
FOR THE
PISTON MOTOR ASSEMBLY

DISASSEMBLY

1. Clean outside of unit thoroughly.
2. Remove snap ring (1) from housing assembly (10).
3. Clamp shaft in a protected jaw vise with backplate end up.
4. Remove snap ring (27) and shaft seal (26) from backplate (23).
5. Remove capscrews (24 & 25) from backplate (23).
6. Use a plastic mallet and tap the backplate (23) to loosen it; then pull the backplate straight out.
7. Remove o-ring (22) from backplate.
8. Remove the complete piston block assembly from the housing assembly.
9. Remove piston assemblies (12), spider (13), and pivot (14) from the piston block assembly.
10. The piston block assembly need not be disassembled unless the internal pins (17) or spring (19) is damaged.

CAUTION

The following procedure should be used if the spring (19) is to be removed from the piston block. The spring is highly compressed and the snap ring (20) should not be removed without compressing the spring (19).

The following parts will be needed to disassemble the piston block:

- 2 each 5/16 I.D. X 15/16 O.D. flat washers
- 1 each 5/16 X 2-7/8 N.C. capscrew, and
- 1 each 5/16 N.C. nut

Place one of the flat washers over the capscrews and place this through the center of the piston block. Place the other washer over the capscrew and let it rest on the three pins (17). Screw the nut on and compress the spring inside the piston block. Use a pair of snap ring pliers and remove the internal snap ring (20). Remove the capscrew and two washers. Remove the spring (19), washer (18), pin keeper (16), and the three pins (17).

11. Remove camplate insert (11) from housing.
12. Remove shaft seal (2) from housing.
13. Remove spacer (3) and drive shaft (8) from housing.

14. Remove the two snap rings (4), thrust washers (5), and thrust bearing (6) from drive shaft.

INSPECTION

1. Wash all parts thoroughly in a suitable solvent.
2. Examine needle bearings (9) and (21) in housing (10) and backplate (23). If the needles are free of excessive play and remain in the bearing cage, there is no need to replace the bearing.
3. Inspect thrust washers (5) and thrust bearing (6). All surfaces should be free of any signs of wear or fretting.
4. Inspect spider (13) and pivot (14); conical surfaces should be free of wear and score marks.
5. Inspect the pistons (12); the O.D. surface should be smooth and free of scoring. The shoes should be snug fit to the piston. The face of the shoes should be flat and free of scoring and flaking. Do not lap piston shoes.
6. Inspect the piston block (15); the bores should be free of scoring. The surface that contacts the backplate should be smooth and free of grooves or metal build-up.
7. Inspect the cam. insert (11); the surface opposite the chamfered side should show no signs of scoring.
8. Inspect the flat surface on the backplate (23); it should be free of excessive scoring or metal build-up.
9. Inspect the drive shaft (8) for fretting in the bearing areas. Check spline area for twisted or broken teeth. If keyed shaft, check for cracked or chipped keyway.

REASSEMBLY

1. Lubricate all critical moving parts before assembly.
2. Install one snap ring (4) in rear groove on drive shaft (8). Install one thrust washer (5), thrust bearing (6), and second thrust washer (5) on drive shaft (8). Install second snap ring (4) in front groove on drive shaft.
3. Replace needle bearing (9) in housing (10) if necessary. Install shaft in housing assembly (10). Install washer (3), shaft seal (2) and retain with snap ring (1).
4. Compress pin keeper (16) and install in the spline I.D. of the piston block (15).

5. Install the three pins (17), washer (18), and spring (19) in piston block. Use the 5/16 I.D. washers and the 5/16 X 2-7/8 capscrew to compress the spring and retain with snap ring (20). Remove the 5/16 X 2-7/8 capscrew and the two washers.
6. Install the pivot (14), spider (13), and the piston assemblies (12) in the piston block assembly.
7. Lubricate cam insert (11) and install in housing assembly with chamfered edge of race against housing surface.
8. Install piston block assembly in housing assembly. The piston shoes must contact the cam insert (11). Be sure all parts are in their proper position.
9. Install new needle bearing (21) in backplate (23) if necessary.
10. Install new o-ring (22) on backplate.
11. Install backplate (23) on housing - the shoes should be flat and free of scoring and flaking. Do not lap piston shoes.
6. Inspect the piston block (15); the bores should be free of scoring. The surface that contacts the backplate should be smooth and free of grooves or metal build-up.
7. Inspect the cam insert (11); the surface opposite the chamfered side should show no signs of scoring.
8. Inspect the flat surface on the backplate (23); it should be free of excessive scoring or metal build-up.
9. Inspect the drive shaft (8) for fretting in the bearing areas. Check spline area for twisted or broken teeth. If keyed shaft, check for cracked or chipped keyway.

REASSEMBLY

1. Lubricate all critical moving parts before assembly.
2. Install one snap ring (4) in rear groove on drive shaft (8). Install one thrust washer (5), thrust bearing (6), and second thrust washer (5) on drive shaft (8). Install second snap ring (4) in front groove on drive shaft.
3. Replace needle bearing (9) in housing (10) if necessary. Install shaft in housing assembly (10). Install washer (3), shaft seal (2) and retain with snap ring (1).
4. Compress pin keeper (16) and install in the spline I.D. of the piston block (15).

MOTOR TROUBLE SHOOTING

In trouble shooting a pump-motor system it is necessary to isolate the pump from the motor to determine which unit is actually malfunctioning. A worn pump or worn motor will both give the same system indication. Therefore, it is advisable to first run a pressure and flow check on the pump to make sure it is performing within its operating specifications. The following trouble shooting suggestions are based on the assumption that the pump has been flow and pressure checked and has been found within operating specifications.

POSSIBLE TROUBLE	CAUSES	REMEDIES
1. Motor turns while unloaded but slows down or stops when load is applied.	<p>A. Scored back plate.</p> <p>B. Scored or worn piston shoes.</p> <p>C. Low relief valve pressure.</p>	<p>A. Remove back plate and examine surface condition of flat area; if scored, replace back plate. Do not lap.</p> <p>B. Disassemble motor, examine condition of shoes on pistons; replace pistons as a complete set if necessary.</p> <p>C. Check relief valve for proper pressure setting; adjust or replace relief valve.</p>
2. Motor will not turn.	<p>A. Severely scored back plate.</p>	<p>A. Disassemble motor completely. Inspect all parts, clean all parts, replace all worn parts and flush hydraulic system.</p>
3. Motor free wheels.	<p>A. Oil flow and pressure shut off going to motor.</p>	<p>A. When the hydraulic system is shut off, either by shutting off the engine on a closed loop system or returning the control valve spool to neutral on an open center system, the motor will free wheel after it has leaked off. This is inherent in the design. On a closed loop or propulsion system, the motor will not free wheel as long as charge pressure is maintained to and from the motor.</p>
4. Excessive case drain flow.	<p>A. Excessive internal wear in motor.</p>	<p>A. Disassemble motor, inspect parts and replace as necessary. Case drain flow should not exceed 1.5 GPM at full pressure.</p>



Overhaul Manual

GEAR PUMP

G2020*-*****-**30

G3020*-*****-**31

G3030*-*****-**31

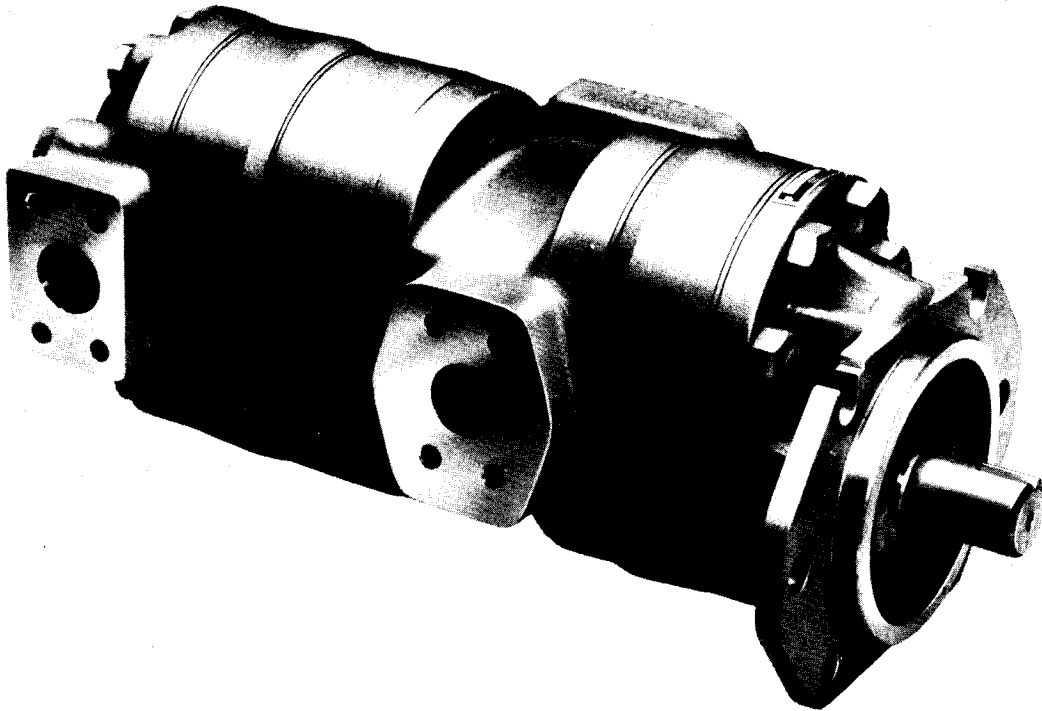

Vickers, Incorporated

1401 Crooks Road
Troy, Michigan 48084

Revised 11-1-87 M-2390-S

SECTION	TABLE OF CONTENTS	PAGE
I	INTRODUCTION.....	1
	A. Purpose of Manual.....	1
	B. General Information.....	1
II	DESCRIPTION.....	2
	A. General.....	2
	B. Assembly and Construction.....	2
III	PRINCIPLES OF OPERATION.....	3
IV	INSTALLATION AND OPERATING INSTRUCTIONS.....	3
	A. Installation Drawings.....	3
	B. Mounting and Drive Connections.....	3
	C. Shaft Rotation.....	3
	D. Piping and Tubing.....	3
	E. Hydraulic Fluid Recommendations.....	4
	F. Cleanliness.....	4
	G. Sound Level.....	4
	H. Overload Protection.....	4
	I. Start-Up.....	4
V	SERVICE, INSPECTION AND MAINTENANCE.....	4
	A. Service Tools.....	4
	B. Inspection.....	6
	C. Adding Fluid to the System.....	6
	D. Adjustments.....	6
	E. Lubrication.....	6
	F. Replacement Parts.....	6
	G. Trouble Shooting.....	6
VI	OVERHAUL.....	7
	A. General.....	7
	B. Disassembly.....	7
	C. Inspection and Repair.....	9
	D. Assembly.....	9
VII	TEST.....	11
	A. Break-In Test Conditions.....	11
	B. Break-In Test Procedures.....	11

SECTION I - INTRODUCTION

A. PURPOSE OF MANUAL

This manual is to assist users of Vickers high performance double gear pumps in properly installing, maintaining and repairing their units. The double gear pumps are described in detail.

Their theory of operation is discussed and instructions for installation, maintenance and overhaul are presented.

The general series of models covered include the G2020, G3020 and G3030. The information given applies to the latest design series.

B. GENERAL INFORMATION

1. Related Publications - Service parts information and installation dimensions are not contained in this manual. The parts and installation drawings listed in Table 1 are available from any Sperry Vickers application engineering office or from:

Vickers, Incorporated
 Technical Publications
 1401 Crooks Road
 Troy, Michigan 48084

2. Model Codes - Variations within each basic model series are covered in the model code. Table 2 is a complete breakdown of the codes covering these units. Service inquiries should always include the complete unit model code number stamped on the rear cover.

MODEL SERIES	PARTS DRAWING	INSTALLATION DRAWING
G2020-30	M-2396-S	MB-203A
G3020-31	M-2397-S	MB-203A
G3030-31	M-2397-S	MB-203A

Table 1. Available Parts and Installation Drawings

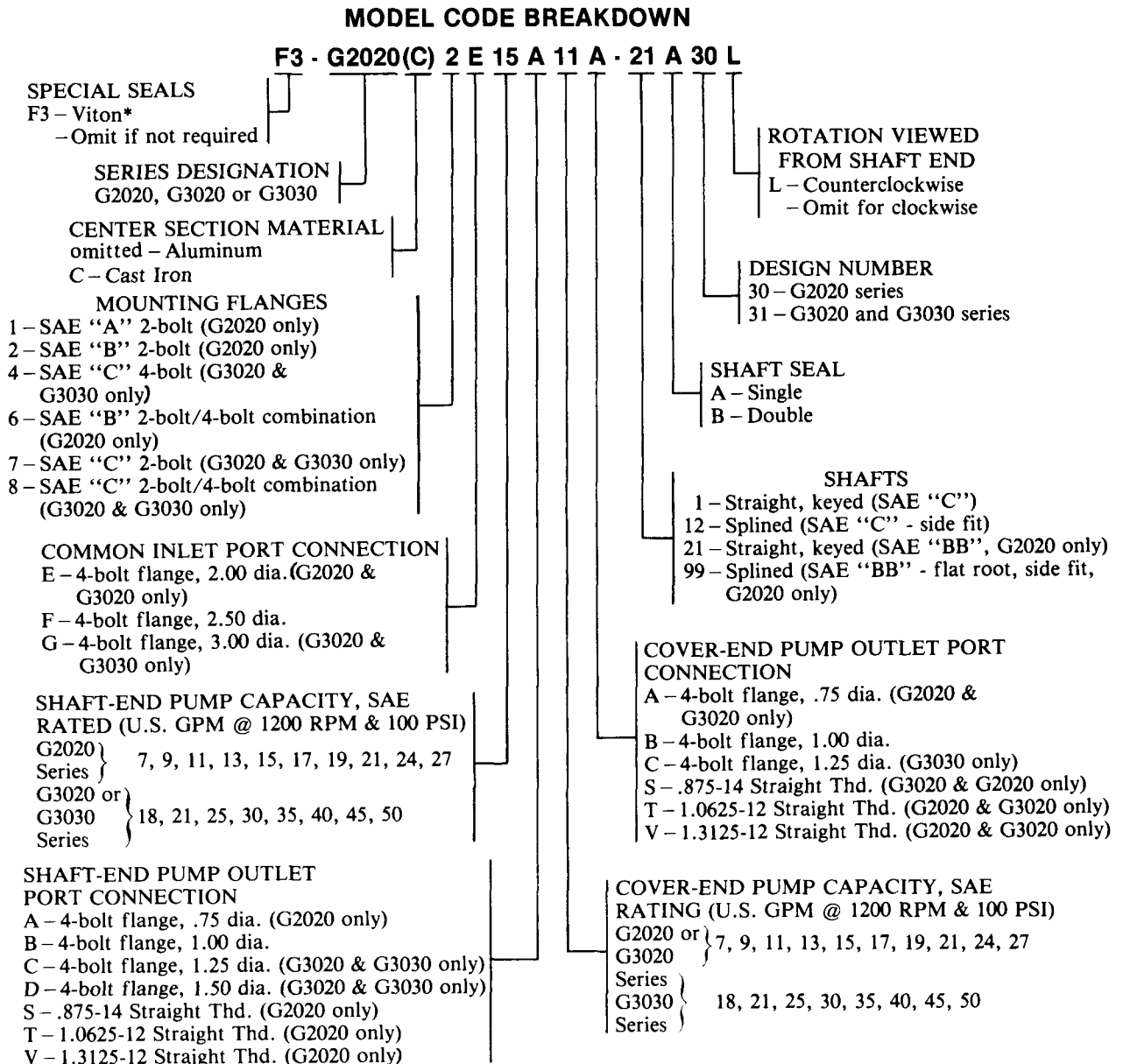

*Registered Trademark of E. I. DuPont DeNemours Co., Inc.

Table 2. Model Code Breakdown

SECTION II - DESCRIPTION

A. GENERAL

Pumps in this series are used to provide fluid flow for the operation of hydraulic driven machinery. The double pump consists of two single pumps, each having its own outlet port, sharing a common inlet port and input shaft. This compact power source is capable of either serving two separate hydraulic circuits, or of supplying greater volume to a single circuit through the combined delivery of both pumps. Since the entire unit requires only one inlet connection and one mounting and drive point, the cost of the total hydraulic installation is generally lower than using two single pumps. The front cover, port section and rear cover are cast iron for reliability, strength and improved sound reduction. Aluminum center sections are machined to enable the gear tips to generate their own paths, creating minimum radial clearance for high volumetric efficiency. Cast iron center sections are available for high pressure applications. The double gear pumps are assembled for clockwise or counterclockwise rotation.

B. ASSEMBLY AND CONSTRUCTION

Basic Pumps - The pump illustrated in Figure 1 is representative of all double pumps in this series. The gear pump consists of a port section, front and rear cover, an adapter section, two center sections, two drive gears, two driven gears, four wear plates, four seal packs, two shaft seals and a shaft coupling. The one piece shaft/gear construction provides maximum strength and allows the use of large bushings for greater load carrying capacity. The gears are carburized, hardened and ground to a super finish. A ten tooth gear design reduces pressure ripple. Steel backed bronze bushings are precision bored in place to provide optimum shaft alignment. The bushings adjust to shafts that are deflected by high hydraulic loads. This greatly increases the life of the pump. The deflectable bronze-faced wear plates are axially pressure loaded and balanced to minimize running clearances and leakage across gear faces, thus increasing operating efficiency. The seal packs mechanically preload the deflectable cantilever section of the wear plates to hold and seal the plates against the gear faces during start-up.

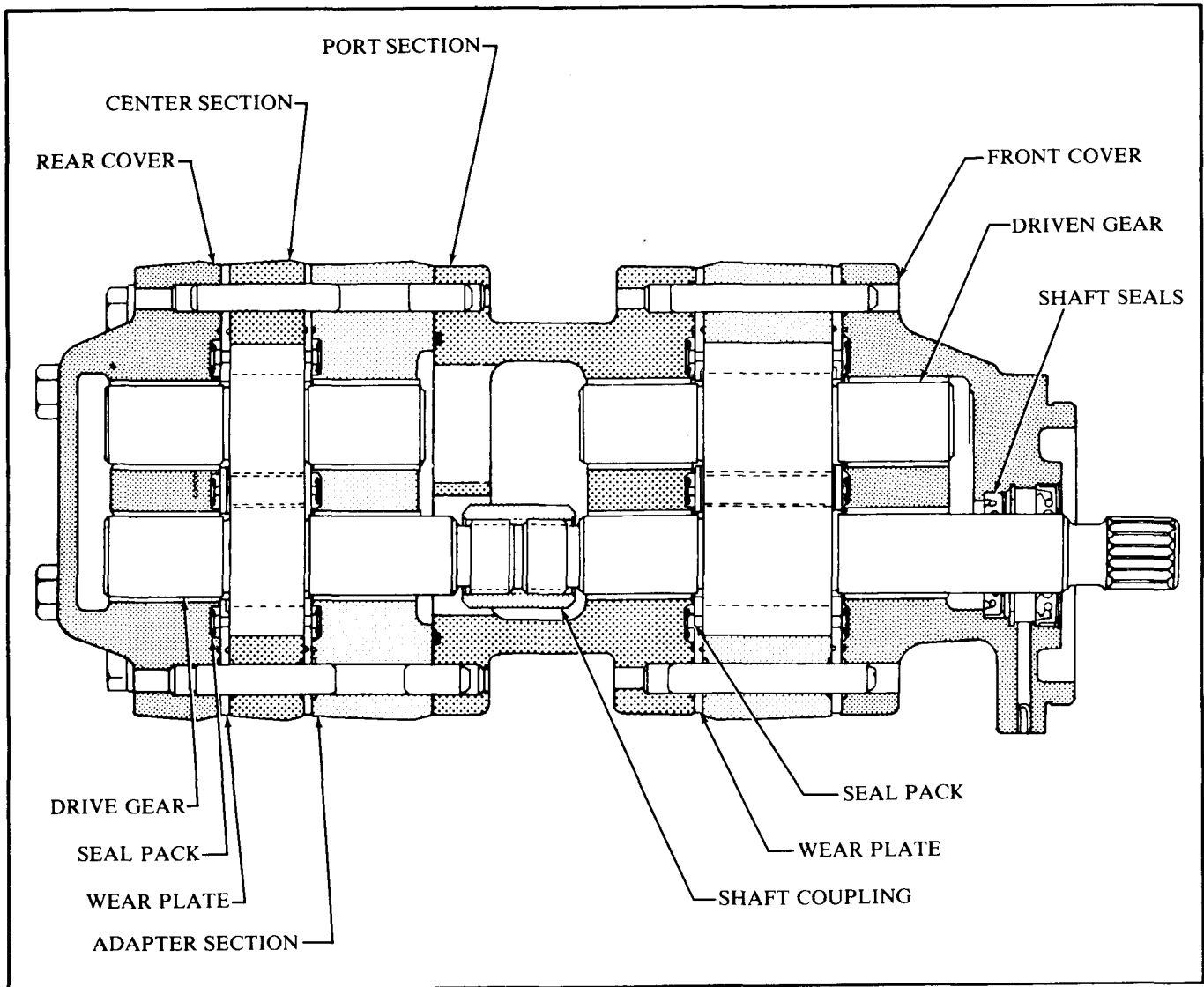

Figure 1. Basic Gear Pump Construction

SECTION III – PRINCIPLES OF OPERATION

The double gear pump is essentially two single gear pumps united with a port section and shaft coupling. The inlet port is located in the port section and is common to both pumps. Refer to Figure 2 for the following explanation. Rotation of the drive and driven gears causes the inlet pressure to decrease. Fluid, pushed into the inlet by atmospheric pressure, is carried to the outlet in chambers formed between the gear teeth and the center section. As the gear teeth mesh, the fluid is forced out through the outlet. The interaction of these two gears, which are the only moving parts within the pump, provide a continuous transfer of fluid from inlet to outlet. Changes in pump volume are accomplished by increasing or decreasing center section width, or by increasing or decreasing pump speed. The outlet port of each pump is located opposite of the inlet port.

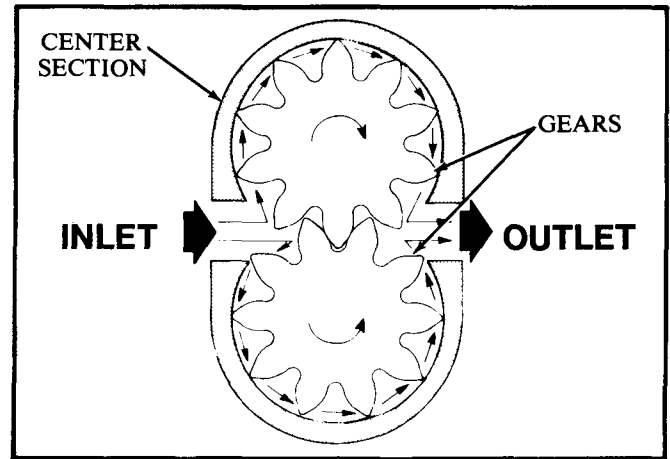

Figure 2. Basic Gear Pump Operation

SECTION IV – INSTALLATION AND OPERATING INSTRUCTIONS

A. INSTALLATION DRAWINGS

The installation drawings listed in Table 1 show overall dimensions and porting options.

B. MOUNTING AND DRIVE CONNECTIONS

Vickers high performance double gear pumps are designed for S.A.E. standard wet flange mountings and are available with single or double shaft seals. Mounting pads meet S.A.E. standards and are available in several sizes and types.

1. Direct Drive - A pilot on the mounting flange (Figure 3) assures correct mounting and shaft alignment, provided the pilot is firmly seated in the accessory pad of the power source. Care should be exercised in tightening all flange mounting screws to prevent misalignment. Shaft keys and couplings must be properly seated to avoid slipping and possible shearing. Proper coupling alignment is essential to prolong pump life.

CAUTION

Shafts are designed to be installed in couplings with a slip fit or very light press. Pounding the coupling on the shaft can ruin the bushings and wear plates. Shaft tolerances are shown on the pump installation drawings. (See Table 1.)

2. Indirect Drive - An indirect drive mounting is subject to engineering approval.

C. SHAFT ROTATION

NOTE

The double gear pump is normally assembled for right hand (clockwise) rotation as viewed from the shaft end. The pump made for left hand (counterclockwise) rotation is identified by an "L" in the model code. (See Table 2.)

CAUTION

Never drive a pump in the wrong rotation. Damage may result to the shaft seal and seal packs.

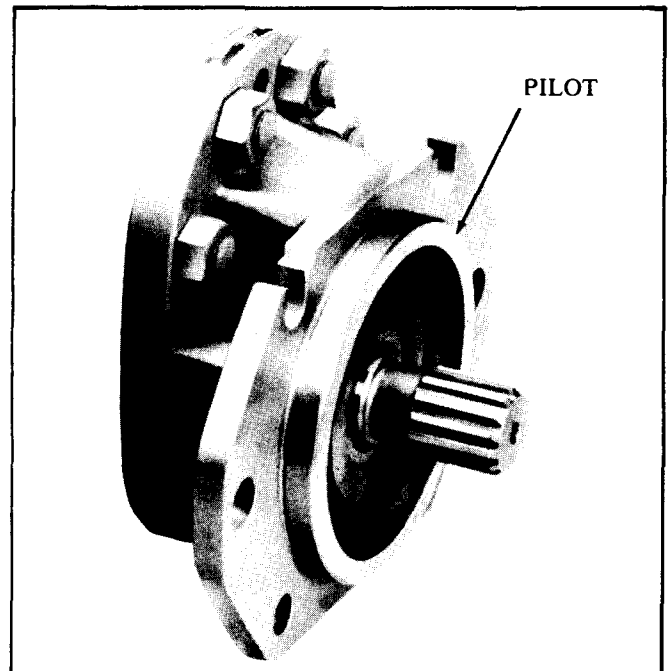

Figure 3. Front Cover Mounting Pilot

D. PIPING AND TUBING

1. All pipes and tubing must be thoroughly cleaned before installation. Recommended methods of cleaning are sandblasting, wirebrushing and pickling.

NOTE

For instructions on pickling, refer to sheet 1221-S.

2. To minimize flow resistance and the possibility of leakage, use only as many fittings and connections as necessary for proper installation.

3. The number of bends in tubing should be kept to a minimum to prevent excessive turbulence and friction of oil flow. Tubing must not be bent too sharply. The recommended radius for bends is three times the inside diameter of the tube.

E. HYDRAULIC FLUID RECOMMENDATIONS

GENERAL DATA

Oil in a hydraulic system performs the dual function of lubrication and transmission of power. It constitutes a vital factor in a hydraulic system, and careful selection of it should be made with the assistance of a reputable supplier. Proper selection of oil assures satisfactory life and operation of system components.

Data sheets for oil selection are available from Vickers, Incorporated, Technical Publications, Troy, Michigan 48084. For Mobile applications, order data sheet M-2950-S. For Industrial applications, order data sheet I-286-S.

The oil recommendations noted in the data sheets are based on our experience in industry as a hydraulic component manufacturer.

Where special considerations indicate a need to depart from the recommended oils or operating conditions, contact your Sperry Vickers representative.

F. CLEANLINESS

To insure the hydraulic system is clean:

1. Clean (flush) entire new system to remove paint, metal chips, welding shot, etc.
2. Filter each change of fluid to prevent introduction of contaminants into the system.
3. Provide continuous fluid filtration to remove sludge and products of wear and corrosion generated during the life of the system.
4. Provide continuous protection of system from entry of airborne contamination, by sealing the system and/or by proper filtration of the air.
5. Proper servicing of filters, breathers, reservoirs, etc., cannot be overemphasized.
6. Good system and reservoir design will insure aeration of fluid is kept to a minimum.

G. SOUND LEVEL

Noise is indirectly affected by the fluid selection, but the condition of the fluid is of paramount importance in obtaining optimum reduction of system sound levels.

Some of the major factors affecting fluid conditions that cause the loudest noises in a hydraulic system are:

1. Very high viscosities at startup temperatures can cause pump noises due to cavitation.
2. Running with a moderately high viscosity fluid will slow the release of entrained air. The fluid will not be completely purged of such air in the time it remains in the reservoir and will be recycled through the system.
3. Aerated fluid can be caused by ingestion of air through the pipe joints of inlet lines, high velocity discharge lines, cylinder rod packings, or by fluid discharging above the fluid level in the reservoir. Air in the fluid causes a noise similar to cavitation.
4. Contaminated fluids can cause excessive wear of internal pump parts, which may result in increased sound levels.

H. OVERLOAD PROTECTION

Relief valves must be installed in the system as close to the pump outlets as possible. The relief valves limit pressure in each system to a prescribed maximum and protects components from excessive pressure. Each relief valve pressure setting depends on the work requirements of the circuit being fed and should not exceed the pressure ratings of the pump.

I. STARTUP

Whenever it is possible to do so, fill the pump ports with system fluid. This will make it easier for the pump when it is first started.

Self Priming - With a minimum drive speed of 600 RPM, a pump should prime immediately. Failure to prime within a short length of time may result in damage due to lack of lubrication. Inlet lines must be tight and free from air leaks. However, it may be necessary to loosen a fitting on the outlet side of the pump to allow entrapped air to escape.

No Load Starting - These pumps are designed to start up with no load on the pressure ports. They should never be started against a load or a closed center valve.

SECTION V – SERVICE, INSPECTION & MAINTENANCE

A. SERVICE TOOLS

No special tools are required for the disassembly or assembly of the double gear pump with the exception of a shaft seal driver for the G20** and G30**. See Figures 4 through 7. The following standard tools are required:

1. Screwdriver (6 inch)
2. Socket set with ratchet (½ inch drive)
3. Plastic hammer (Compuhane, Model X-1 HD, or equivalent)
4. Torque wrench box end adapter (Sturtevant Co. P/N BX-11/16)
5. Torque wrench box end adapter (Sturtevant Co. P/N BX-7/8)
6. Torque wrench (0-200 lb. ft.)
7. Torque wrench (0-200 lb. in.)
8. Internal retaining ring pliers (Truarc #23)
9. Internal retaining ring pliers (Truarc #25)

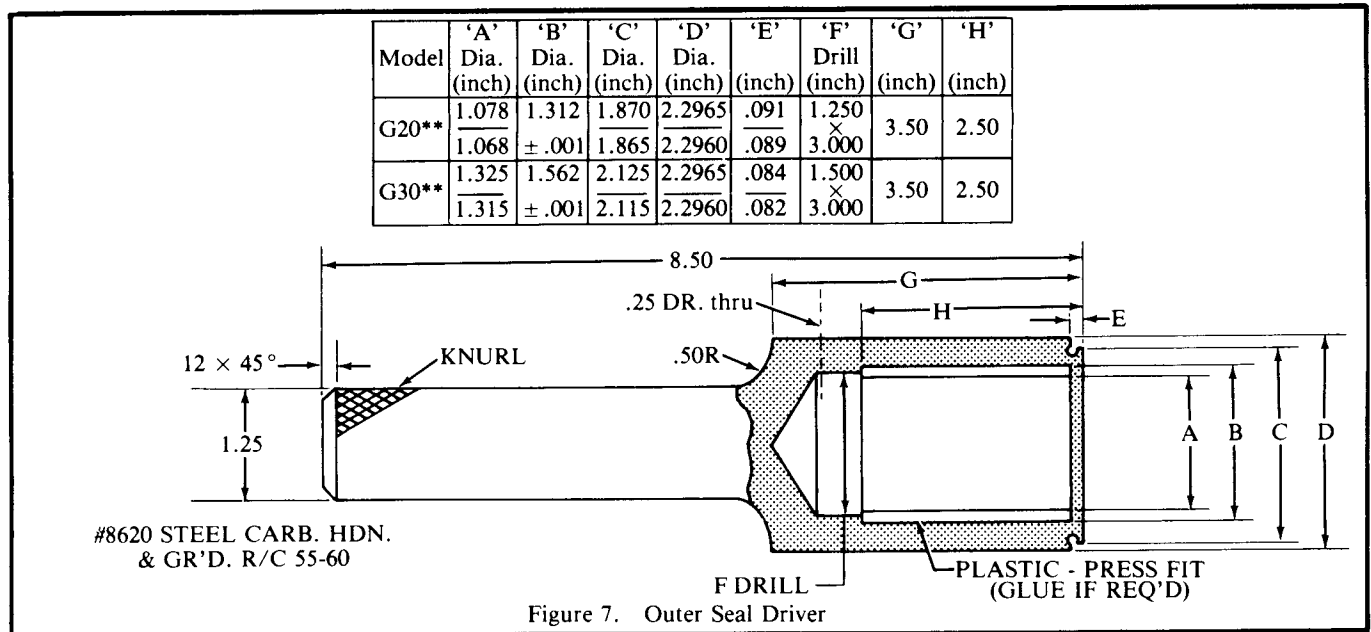
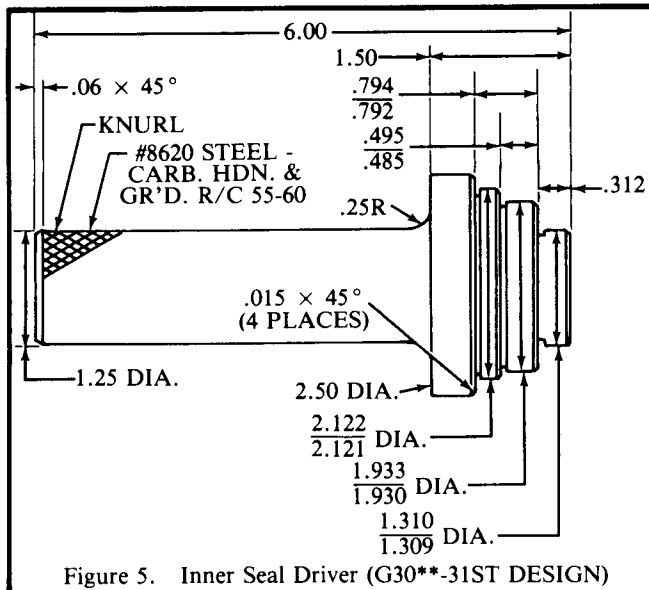
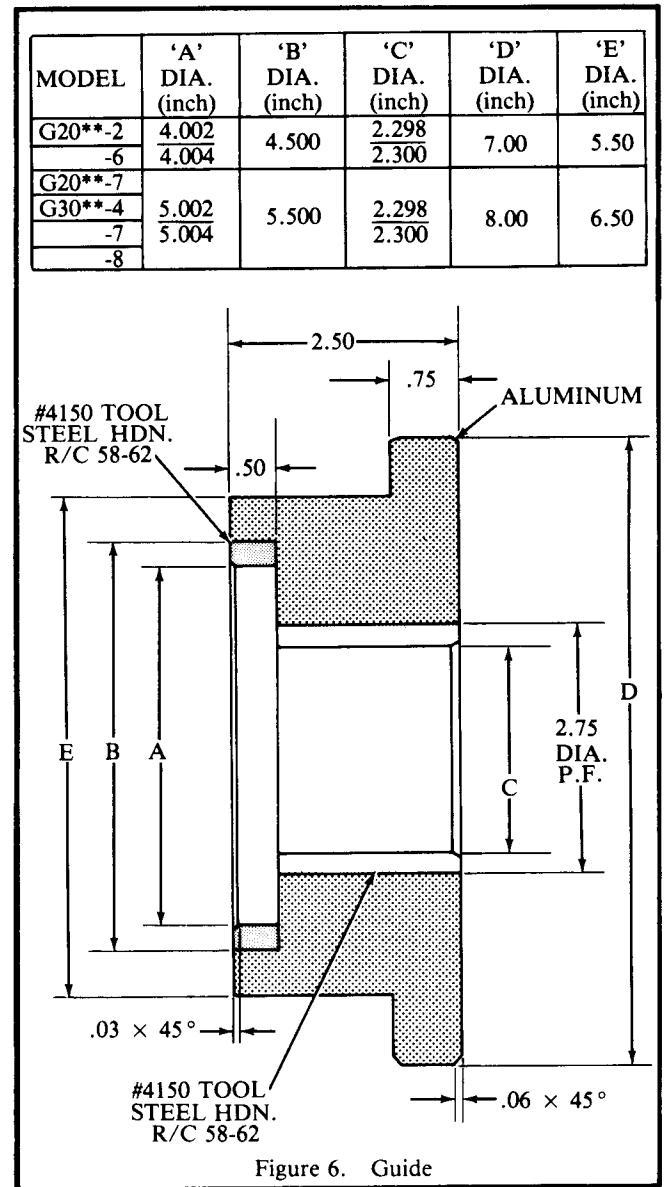
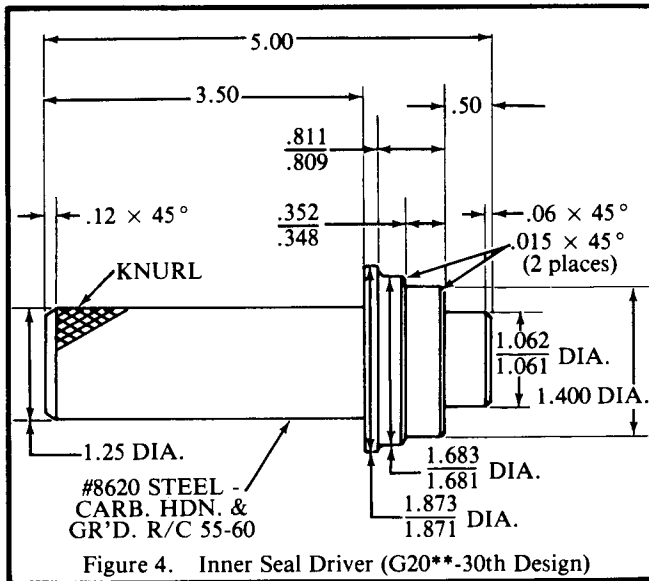

B. INSPECTION

Periodic inspection of the fluid condition and tube or piping connections can save time-consuming breakdowns and unnecessary parts replacement. The following should be checked regularly:

1. All hydraulic connections must be kept tight. A loose connection in a pressure line will permit the fluid to leak out. If the fluid level becomes so low as to uncover the inlet pipe opening in the reservoir, extensive damage to the pump may result. In suction or return lines, loose connections permit air to be drawn into the system, resulting in noisy and/or erratic operation.

2. Clean fluid is the best insurance for long service life. Therefore, the reservoir should be checked periodically for dirt or other contaminants. If the fluid becomes contaminated, the system should be thoroughly drained and the reservoir cleaned before new fluid is added.

3. Filter elements also should be checked and replaced periodically. A clogged filter element results in a higher pressure drop. This can force particles through the filter or can cause the by-pass to open, resulting in a partial or complete loss of filtration.

4. Air bubbles in the reservoir can ruin the pump and other components. If bubbles are seen, locate the source of the air and seal the leak.

5. A pump which is running excessively hot or noisy is a potential failure. Should a pump become noisy or overheated, the machine should be shut down immediately and the cause of improper operation corrected.

C. ADDING FLUID TO THE SYSTEM

When hydraulic fluid is added to replenish the system, it should always be poured through a fine wire screen (200 mesh

or finer) or preferably pumped through a 10 micron (absolute) filter.

It is important that the fluid be clean and free of any substance which could cause improper operation or wear of the pump or other hydraulic components. Therefore, the use of cloth to strain the fluid should be avoided to prevent lint from getting into the system.

D. ADJUSTMENTS

No periodic adjustments are required, other than to maintain proper shaft alignment with the driving medium.

E. LUBRICATION

Internal lubrication is provided by the fluid in the system. Lubrication of the input drive shaft coupling should be specified by its manufacturer.

F. REPLACEMENT PARTS

Reliable operation throughout the specified range is assured only if genuine Vickers parts are used. Sophisticated design processes and materials are used in the manufacture of our parts. Substitutions may result in early failure. Parts service drawings are shown in Table 1.

G. TROUBLESHOOTING

Table 3 lists the common difficulties experienced with gear pumps and hydraulic systems. It also indicates the probable causes and remedies for each of the troubles listed.

It should always be remembered that many apparent pump failures are actually the failure of other components in the system. The cause of improper operation is best diagnosed with adequate testing equipment and thorough understanding of the complete hydraulic system.

TROUBLE	CAUSE	REMEDY
I. Excessive noise	<ol style="list-style-type: none"> 1. Low oil level in reservoir 2. Air in system 3. Oil too thick 4. Damaged or missing seals inside pump 	<p>Fill reservoir to proper level. Bleed hydraulic lines at highest point downstream of pump. Warm up pump in cold weather. Locate and replace seals.</p>
II. Pump overheating	<ol style="list-style-type: none"> 1. Heat exchanger not functioning properly 2. Bushings partially seized inside unit 3. Pump assembly incomplete 	<p>Locate and repair. Locate and replace necessary parts. Check pump assembly.</p>
III. System not developing pressure	<ol style="list-style-type: none"> 1. Relief valve stuck open 2. Gear pump assembled for opposite rotation 3. Pump inlet/outlet connections reversed 4. Disconnected or broken drive mechanism 	<p>Repair or replace. Reassemble pump for proper rotation. Reverse inlet/outlet connections. Repair or replace.</p>
IV. Pump delivery (flow) too low	<ol style="list-style-type: none"> 1. Burrs on mating surfaces 2. Damaged or missing seals inside unit 3. Center section/gear clearance not to specifications 	<p>Disassemble unit and remove burrs. Replace damaged or missing seals. Return to shop for evaluation and repair.</p>
V. Loss of fluid	<ol style="list-style-type: none"> 1. Ruptured hydraulic line 2. Leaking or missing seals 3. Bolts or nuts not torqued to specifications 4. Seized bushings 	<p>Replace ruptured line. Replace seals. Torque to specifications. Replace necessary parts.</p>

Table 3. Trouble Shooting Chart

SECTION VI – OVERHAUL

A. GENERAL

During disassembly, pay particular attention to identification of the parts for correct assembly. Figure 8 is an exploded view which shows the proper relationship of parts for disassembly and assembly.

WARNING

Before breaking a circuit connection, make certain that power is off and system pressure has been released. Lower all vertical cylinders, discharge accumulators and block any load whose movement could generate pressure. Plug all removed units and cap all lines to prevent the entry of dirt into the system.

B. DISASSEMBLY

A clean work area is most essential for disassembly of the double gear pump. A work bench (6 foot), bench vise (6 inch), cleaning tank and shop air are also useful. Kraft paper to lay disassembled parts out should be used. Due to the similarity of parts, they should be placed in an orderly manner on the Kraft paper to avoid mixing the parts during assembly. All shaft seals, "O" rings and seal packs removed must be discarded.

1. Cover end pump disassembly - The G2020, G3020 and G3030 cover end pumps are disassembled in the same manner. Clamp the port section (16) in a vise with protective jaws to avoid damage to the port section's machined surfaces. Disassemble the cover end pump as follows:

- a. Remove the four short screws (1) and four washers (2).
- b. Remove the four long screws (3) and four washers (4).
- c. Remove the rear cover (5) from wear plate (7). Remove seal pack (6) from rear cover and discard.
- d. Remove wear plate (7) from center section (10).
- e. Remove drive gear (8) and driven gear (9) from center section (10).
- f. Removal of the center section (10) from wear plate (11) may necessitate the use of a plastic hammer.
- g. Lift wear plate (11) from adapter (12).
- h. Remove seal pack (13) from adapter (12) and discard.

ITEM	NOMENCLATURE	QTY	ITEM	NOMENCLATURE	QTY
1	Screw (short)	4	16	Port Section	1
2	Lock Washer	4	17	Nut	8
3	Screw (long)	4	18	Lock Washer	8
4	Lock Washer	4	19	Shaft End Cover S/A	1
5	Rear Cover S/A	1	20	Seal Pack	1
6	Seal Pack	1	21	Wear Plate (front)	1
7	Wear Plate (front)	1	22	Driven Gear	1
8	Drive Gear	1	23	Drive Gear	1
9	Driven Gear	1	24	Center Section	1
10	Center Section	1	25	Wear Plate (rear)	1
11	Wear Plate (rear)	1	26	Seal Pack	1
12	Adapter Section	1	27	Shaft Seal (outer)	1
13	Seal Pack	1	28	Retaining Ring	1
14	Coupling	1	29	Shaft Seal (inner)	1
15	"O" Ring	1	30	Stud	8

Figure 8. Part Nomenclature

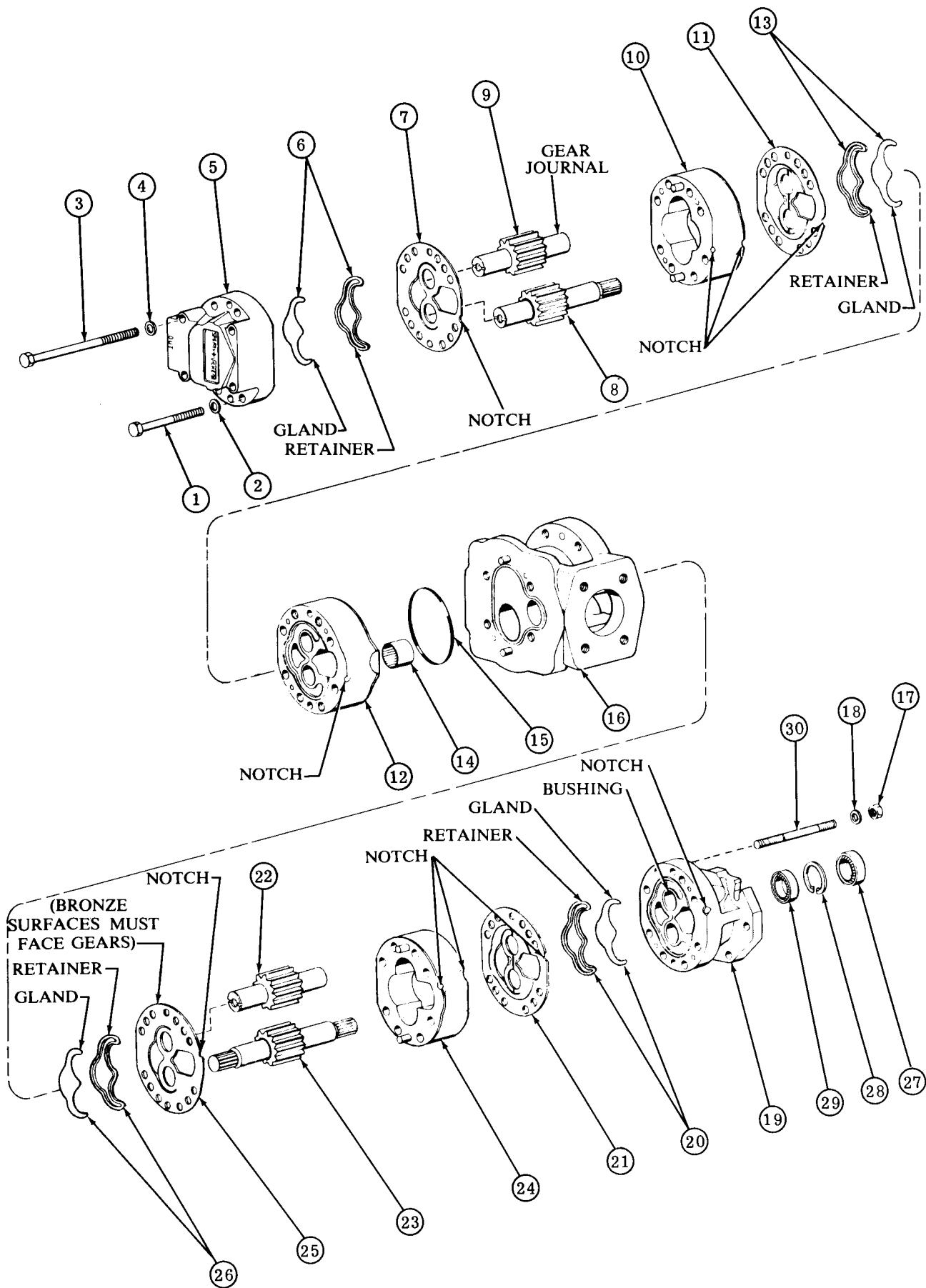

Figure 8. Double Gear Pump, Exploded View

- i. Remove adapter (12) from port section (16).
- j. Remove "O" ring (15) from port section (16) and discard.
- k. Remove gear coupling (14) from port section (16).

This completes the disassembly of the cover end gear pump.

2. Shaft end pump disassembly - G2020, G3020 and G3030 shaft end pumps are disassembled in the same manner. With the port section clamped in a vise as previously described, disassemble the shaft end pump as follows:

- a. Remove eight nuts (17) and eight washers (18).
- b. Remove front cover (19) from wear plate (21).
- c. Remove seal pack (20) from front cover (19) and discard.
- d. Remove wear plate (21) from center section (24).
- e. Remove drive gear (23) and driven gear (22) from center section (24).
- f. Removal of the center section (24) may necessitate the use of a plastic hammer.
- g. Remove wear plate (25) from port section (16).
- h. Remove seal pack (26) from port section (16) and discard.

This completes disassembly of the shaft end pump.

CAUTION

If the shaft end pump or the cover end pump is suspected of failure, both pumps must be disassembled and inspected.

C. INSPECTION AND REPAIR

Cleaning - All parts must be thoroughly cleaned and kept clean during inspection and assembly. The close tolerance of the parts makes this requirement very important. Paint found on the edges of all parts must be removed. Clean all removed parts, using a commercial solvent that is compatible with the system fluid. Compressed air may be used in cleaning, but it must be filtered to remove water and contamination.

A new seal kit is required for assembly. Refer to parts drawing noted in Table 1 for seal kit numbers. Wash the metal parts, blow them dry with air and place on a clean surface (Kraft paper) for inspection.

1. Front cover S/A - To remove the double shaft seal, perform the following steps:

- a. Place front cover S/A in a vise (mounting flange up). Using a screwdriver, pop out the outer shaft seal (27) being careful not to raise a burr on the shaft seal bore.
- b. Remove the retaining ring (28) with internal retaining ring pliers.
- c. Remove front cover S/A (19) from vise and place on work bench with mounting flange down. Using a bronze drift and hammer, drive inner shaft seal (29) out through mounting flange being careful not to damage bearing.

d. Inspect the drive and driven gear bushings of front cover (19) for pickup, scoring, discoloration or excessive wear. Any of the preceding conditions shall warrant replacement of the front cover S/A. Inspect mounting flange for nicks and burrs. Remove with india stone.

2. Wear plates (7), (11), (21) and (25) - Inspect for erosion, pitting, scratches and/or scoring. Replace if necessary.

3. Center sections(10) and (24) - Inspect for porosity, cracks, and scratches (.010 or deeper). Replace if necessary. DO NOT deburr the figure eight edge of the center section.

4. Drive gears (8) and (23) - Inspect splines for nicks or excessive wear. Inspect gear journals for scratches and discoloration. *Any discoloration warrants replacement.* Inspect gear teeth for spalling, scratches and/or excessive wear. Replace if necessary. Stoning teeth to remove burrs is permissible. The face of the gear teeth should also be inspected for scratches.

5. Driven gears (9) and (22) - Same procedure as step 4.

6: Port section (16) - Inspect the drive and driven gear bushings for pickup, scoring, discoloration and/or wear. *Any of the preceding conditions shall warrant replacement of the port section.* Inspect inlet flange for nicks and burrs. Stone to remove. Inspect studs (30) for cross threads, cracks and burrs. If studs are defective, remove as follows: Install a nut (17) on the stud as far as possible. Then install another nut over the first one and tighten to lock in place. Apply torque to the first nut and remove the stud. Refer to parts drawing noted in Table 1 for stud part numbers and installation instructions.

7. Adapter (12) - Inspect the drive and driven gear bushings for pickup, scoring, discoloration and/or wear. *Any of the preceding conditions shall warrant replacement of the adapter.*

8. Rear Cover (5) - Inspect the drive and driven gear bushings for pickup, scoring, discoloration and/or wear. *Any of the preceding conditions shall warrant replacement of the rear cover.*

D. ASSEMBLY

NOTE

Coat all parts with clean hydraulic fluid to facilitate assembly and provide initial lubrication. Use small amounts of petroleum jelly to hold seal packs (seal gland and retainer) in place during assembly.

1. Assemble seal packs by inserting the seal glands into the seal retainers. Install seal packs on the following parts prior to assembly with the seal retainers facing up.

- a. Install seal pack (6) into cavity located on face of rear cover (5).
- b. Install seal pack (13) into cavity located on face of adapter (12).
- c. Install seal pack (26) into cavity located on face of port section (16).

2. Shaft end pump assembly - Place port section (16) in vise with studs facing up. Assemble the shaft end of pump as follows:

NOTE

The following steps (3.a. and 3.b.) pertain to installation of front cover shaft seals. Lubricate the shaft seal(s) with Marfak grease to provide initial lubrication.

a. Install inner shaft seal (29) into front cover (19). Make sure the spring loaded member of shaft seal faces the inside of pump. Use one of the shaft seal drivers shown in Table 4. Place the shaft seal on driver and press in place. Install retaining ring (28) into front cover on top of shaft seal.

MODEL	USE DRIVER SHOWN IN
G20**-30th Design	Figure 4
G30**-31st Design	Figure 5

Table 4. Inner Shaft Seal Drivers

b. Double shaft seal arrangement - Perform step 3.a. and then install the outer shaft seal (27) into front cover. Install outer shaft seal as follows: Place a guide over the pilot diameter of front cover. Next, install a new outer shaft seal (27) on the driver. Make sure the spring loaded member of shaft seal faces the inside of pump. Finally, insert the driver and shaft seal through the guide and press in place. Refer to Table 5 for proper guide and driver.

MODEL CODE (Mounting)	PILOT DIA. (Inches)	GUIDE	DRIVER
G20**-2	4.00	See Figure 6	See Figure 7
G20**-6	4.00		
G20**-7	5.00		
G30**-4	5.00		
G30**-7	5.00		
G30**-8	5.00		

Table 5. Outer Shaft Seal Guide and Driver

c. Place wear plate (25) on port section (16) with bronze face up and notch facing inlet port.

d. Lubricate bronze face of wear plate (25). Install center section (24) on top of wear plate (25) and into locating holes of port section (16) with major diameter facing port section and notch facing inlet port. Make sure wear plate and center section set flush against port section.

e. Tape the spline area (long spline) of drive gear (23) to prevent cutting shaft seal(s) during assembly.

f. Lubricate drive gear (23) and driven gear (22). Install drive gear (23) into port section (16) with short spline towards port section. Install driven gear (22).

g. Lubricate bronze face of wear plate (21). Install wear plate (21) over locating pins of center section (24) with bronze face towards center section and notch facing inlet port.

h. Install seal pack (20) into cavity located on face of front cover (19). Apply petroleum jelly around seal pack area on face of front cover.

i. Carefully position front cover (19) over studs, gears and center section guide pins. Gently slide front cover over the gears until it is flush against wear plate (21).

j. Lubricate stud (30) threads with hydraulic fluid. Install washers (18) and nuts (17) on ends of studs. Cross torque nuts to 115 -5 lb.ft. on G30** series and 60 -5 lb.ft. on G20** series.

3. Clamp port section(16) into vise with studs facing down. Make sure port section is clamped securely. Assemble rear cover portion of pump as follows:

a. Install "O" ring (15) into groove located on face of port section (16).

b. Install lubricated coupling (14) on spline of drive gear (23).

c. Lubricate locating pins and face of port section (16). Install adapter (12) over locating pins of port section with notch facing inlet port.

d. Place wear plate (11) on adapter (12) with bronze face up and notch facing inlet port.

e. Lubricate bronze face of wear plate (11) with clean hydraulic fluid. Install center section (10) on top of wear plate (11) with major diameter facing the wear plate and the notch facing inlet port. Locating pins of center section should mate with adapter (12) holes.

f. Make sure the assembly thus far is flush and solid. Lubricate the drive gear (8) and driven gear (9). Install both gears in place. The splined end of drive gear (8) must engage into coupling (14).

g. Lubricate bronze face of wear plate (7) and place over locating pins of center section (10) with bronze face down and notch facing inlet port.

h. Lubricate seal pack (6) area and face of rear cover (5) with petroleum jelly. Carefully place rear cover (5) over locating pins of center section (10) with outlet port opposite inlet port.

i. Lubricate threads of four long screws (3). Place lock washers (4) on screws. Install screws through rear cover (5) and into port section (16). Cross torque screws to values shown in Table 6.

j. Lubricate threads of four short screws (1). Place lock washers (2) on screws. Install screws through rear cover (5) and into adapter (12). Cross torque screws to values shown in Table 6.

MODEL	TORQUE (lb. ft.)	
	ALUMINUM CENTER SECTION	CAST IRON CENTER SECTION
G2020	55-65	65-75
G3020	55-65	65-75
G3030	110-120	145-155

Table 6. Rear Cover Screw Torque

4. Turn the drive gear (23) one revolution with a suitable socket wrench. No binding shall be evident during this operation. The breakaway torque necessary to turn the drive gear must not exceed the values noted in Table 7.

MODEL	TORQUE (lb. in.)
G2020	140
G3020	150
G3030	160

Table 7. Breakaway Torque

SECTION VII - TEST

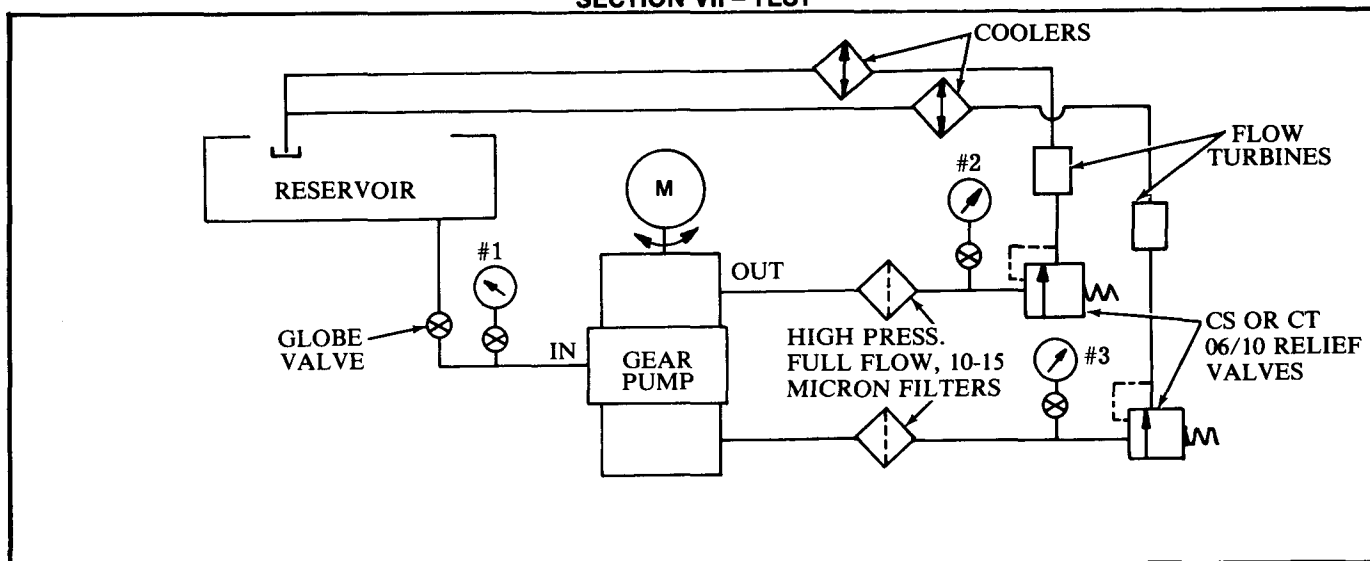

Figure 9. Test Circuit, Double Gear Pump

A. BREAK-IN TEST CONDITION

Test Fluid - Hydraulic fluid in accordance with Vickers data sheet M-2950-S or I-286-S and having a viscosity between 50 and 80 SUS at 180°F.

Fluid Temperature - Fluid at pump inlet to be maintained at 180°F +10
-40°

Filtration - A high pressure, full flow, 10-15 micron filter system must be fitted immediately after pump outlet to catch particles generated during break in period. The filter system shall not develop back pressure in excess of 50 PSIG at maximum flow.

Inlet Condition - A flooded inlet that maintains 0-15 PSIG at pump inlet port.

B. BREAK-IN TEST PROCEDURE

1. Install gear pump into circuit as shown in Figure 9. Make sure full flow, 10-15 micron high pressure filters are installed at pump outlets. Be sure all connections are tight and the motor is set for proper pump rotation.

2. Fully open globe valve to allow fluid to enter gear pump. Back off relief valve to minimum setting.

3. Turn on system using normal start up procedure.

4. Slowly increase motor speed to 1800 RPM. (NOTE: Inlet pressure gauge #1 should read 0-15 PSIG. Outlet gauges #2 & 3 should read 100-150 PSIG.)

NOTE

During the following steps (5, 7, 8 & 9) DO NOT hold maximum pressure during each cycle more than two seconds. Test the shaft end section first. While testing a section, maintain approximately 100 PSIG on the other section at all times.

5. Slowly increase relief valve setting to 500 PSIG (gauge #2). Immediately back off relief valve to minimum setting (approximately 100 PSIG). Repeat this step five times.

6. Set relief valve to 500 PSIG. Warm up system fluid to 180°F +10
-40°

7. When system fluid temperature is obtained, cycle gear pump five times from 100 PSIG to 1000 PSIG at 1800 RPM.

8. At 1800 RPM, cycle gear pump five (5) times each at increased intervals of 500 PSIG (ie. 100 PSIG to 1500 PSIG, 100 PSIG to 2000 PSIG, etc.) until maximum pressure setting is achieved. See Table 8 for maximum pressure settings.

9. Cycle gear pump ten times from 100 PSIG to rated pressure setting.

10. Maintain rated pressure setting at 1800 RPM. Check minimum flow of pump. See Table 8 for minimum flow requirements.

NOTE

During the preceding tests there shall be no evidence of external leakage.

MODEL	NOM. DEL. @ 1200 RPM @ 100 PSIG	TEST RPM	TEST PRES. PSI	MIN. FLOW @ TEST CONDITIONS USGPM
G20- 7	7	1800	3300	5.5
- 9	9	1800	3300	8.4
-11	11	1800	3300	11.3
-13	13	1800	3300	14.5
-15	15	1800	3000	17.4
-17	17	1800	2750	20.6
-19	19	1800	2500	24.2
-21	21	1800	2250	27.0
-24	24	1800	2250	31.0
-27	27	1800	2000	35.5
G30-18	18	1800	3300	19.8
-21	21	1800	3300	24.2
-25	25	1800	3300	30.0
-30	30	1800	3000	37.6
-35	35	1800	2750	45.3
-40	40	1800	2500	53.0
-45	45	1800	2250	60.7
-50	50	1800	2000	68.5

Table 8. "G" Series Gear Pump Ratings

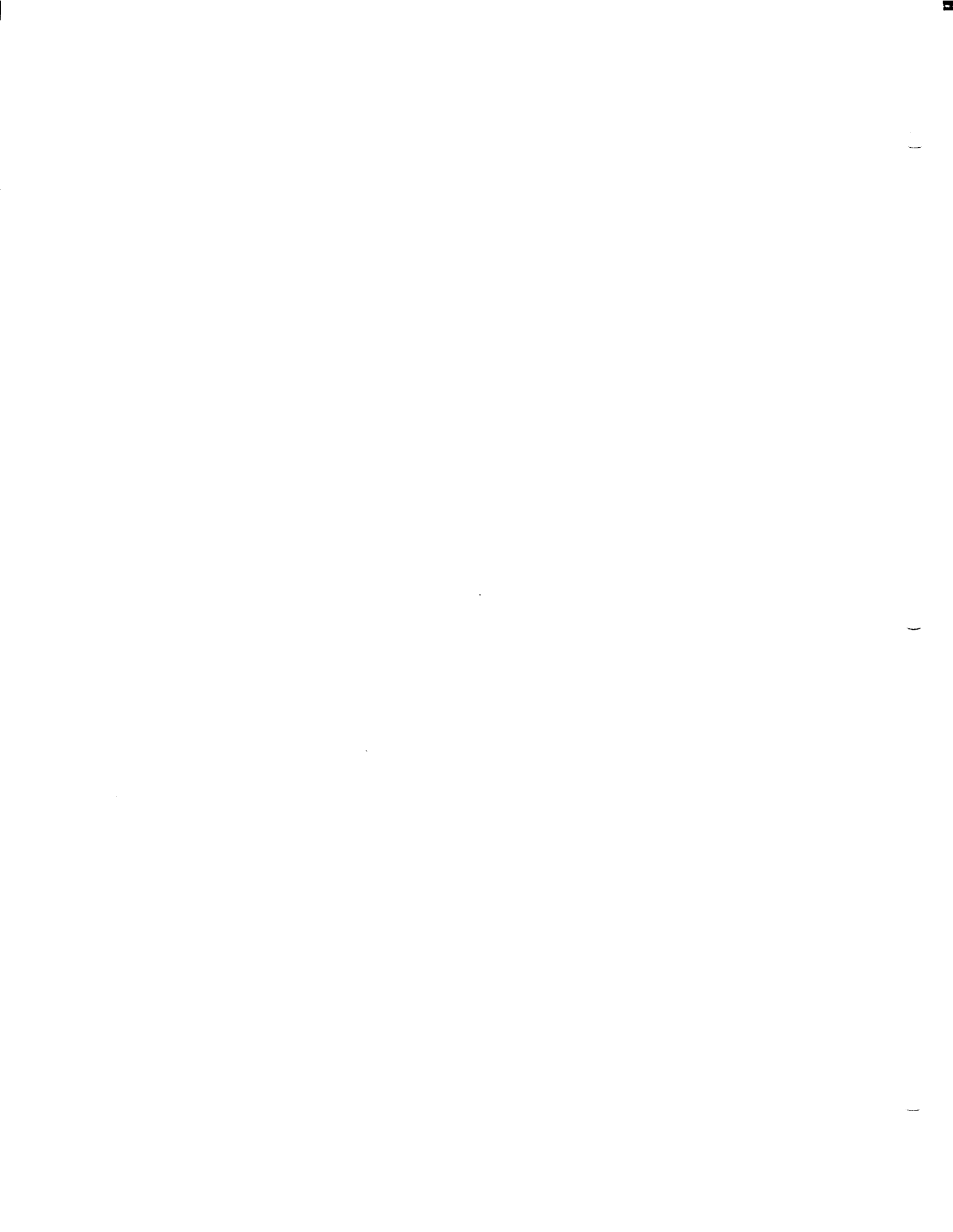



Power Wheel Planetary Gear Drive Service Manual Model 6

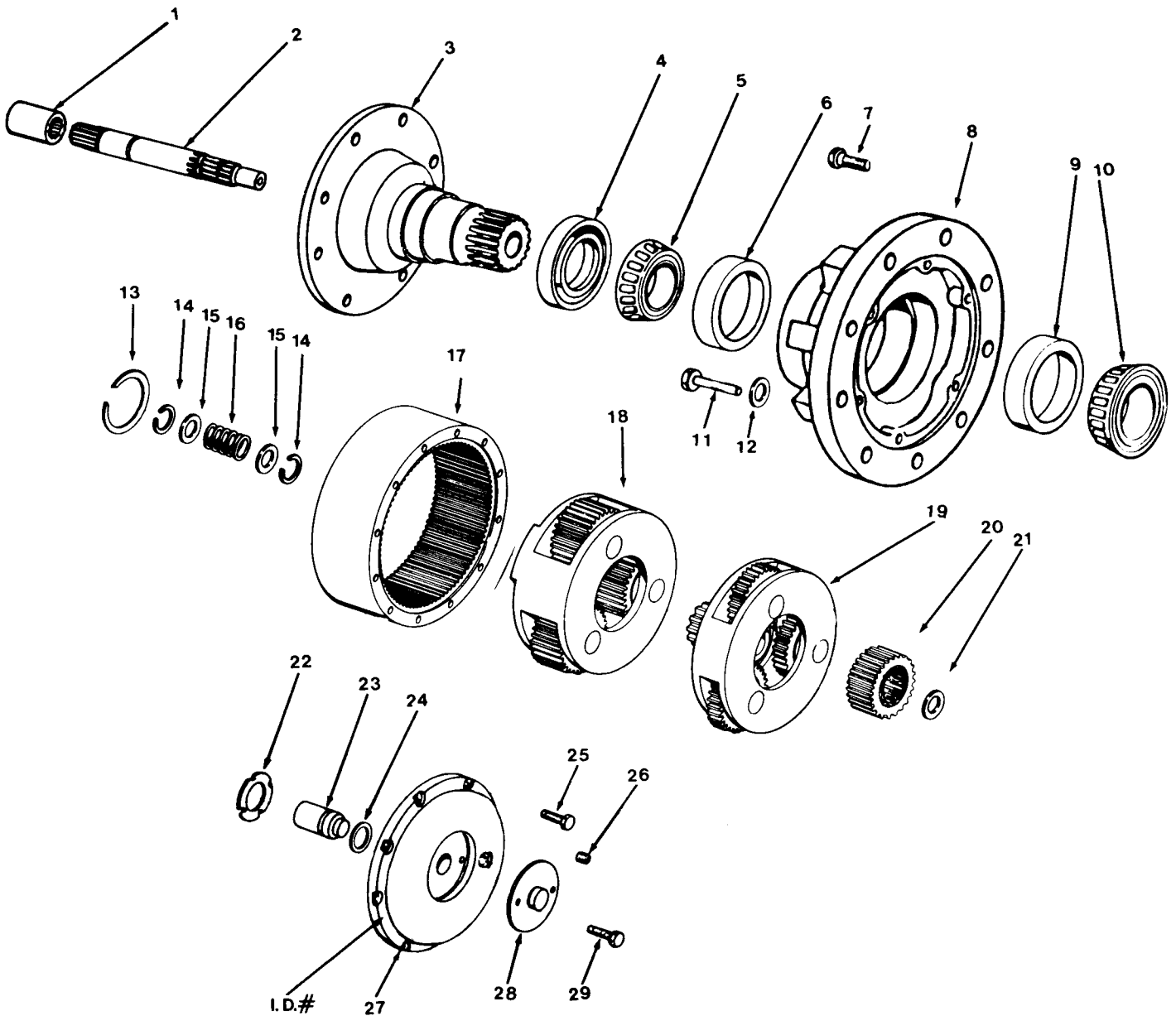

IDENTIFICATION

IMPORTANT: When ordering parts, the information on the large cover is necessary to identify the model to obtain correct replacement parts.

The I.D. # is located on the flange of the cover.

See item # 27.

EXAMPLE "I.D." STAMPED ON COVER

↪ 6 023 M3 04

The 6 following the ↪ indicates that the unit is a "Model 6 Power Wheel" and the 023 identifies the assembly number. Please specify the model and assembly numbers when ordering replacement parts.

DISASSEMBLY OF POWER WHEEL

STEP 1

Slide the coupling (1) from splines on input shaft (2).

STEP 2

Position the assembly upright on face of spindle (3).

STEP 3

Remove the disengage cover (28).

STEP 4

Remove bolts (25) and large cover (27). Disengage plunger (23) usually remains with cover. Remove plunger and "O" ring from cover on end of input shaft.

STEP 5

A thrust washer (22) will usually remain in position on thrust face of cover.

STEP 6

Remove sun gear (20) and thrust washer (21) from end of input shaft.

STEP 7

Remove primary carrier (19).

STEP 8

Remove the secondary carrier assembly (18). It may be necessary to remove the ring gear (17) first, if difficulty is encountered in removing the carrier.

STEP 9

Remove input shaft (2) from spindle (3). Remove the retaining rings, washers, and spring from input shaft only if replacement is required.

STEP 10

Remove the 6 or 12 bolts from hub and ring gear and remove ring gear (17). It may be necessary to strike ring gear with a rubber mallet to loosen from hub.

STEP 11

Remove the large retaining ring (13) from in front of the tapered bearing and lift hub (8) from spindle. If bearings are not a loose fit, it may be necessary to press spindle from hub. Note: Use a snap ring expander tool to remove retaining ring.

STEP 12

Remove the oil seal (4) and bearing cones (5 & 10) from hub. Inspect bearing cups in position and remove only if replacement is required (6 & 9).

ASSEMBLY OF POWER WHEEL

STEP 1

Press a new bearing cup, (6 & 9) in each side of the hub (8).

STEP 2

Assemble a bearing cone (5) into cup (6) at seal end of hub and press a new seal (4) into hub.

STEP 3

Position spindle (3) upright on bench. Lubricate lips of seal (4) and lower hub onto spindle. Hub (8) should be centered as it is lowered over spindle to prevent seal damage.

STEP 4

Assemble bearing cone (10) over spindle and into bearing cup (9). Select the thickest retaining ring (13) that can be assembled into ring groove of

spindle shaft above bearing cone. Bearing should have from .000-.006 inches (.00-.15mm) end play when proper retaining ring is installed.

STEP 5

Assemble a retaining ring (14) in groove opposite pilot end of input shaft (2). Assemble a washer, (15) spring, (16) a second washer (15) and a second retaining ring (14) in the middle groove of input shaft. Some shafts have a shoulder and require only one retaining ring.

STEP 6

Assemble the splined end of the input shaft down into spindle.

STEP 7

Assemble secondary carrier splines over splined end of spindle.

STEP 8

Apply a bead of RTV compound to hub face that mates with ring gear (17)*. Assemble the end of ring gear having 6 or 12 bolt holes against hub with bolt holes of hub and ring gear aligned. Assemble the six 3/8-24x1-7/8 inch hex head bolts. Torque bolts to 39-49 (52.9-66.4 Nm) pound feet. If grade 8 bolts are used, the bolts should be torqued to 52-60 (70.5-81.3 Nm) pound feet. Grade 8 bolts can be identified by the 6 radial lines on bolt head.

STEP 9

Assemble the primary carrier and sun gear into ring gear. It will be necessary to rotate carrier and pinion to align sun gear teeth with secondary pinion and primary pinions with ring gear teeth. Assemble the small sun gear (20) over input shaft. Rotate sun gear to align shaft to gear splines and gear teeth.

STEP 10

Assemble the small thrust washer (21) over input shaft and against shoulder of shaft.

STEP 11

Assemble an "O" ring (24) in groove of the disengage plunger (23). Assemble plunger over end of input shaft and against thrust washer.

STEP 12

Lubricate the "O" ring in groove of engage plunger. Assemble the thrust washer (22) with tangs engaged with cover (27). Apply a bead of RTV compound to end face of ring gear.*Assemble cover over plunger as holes of cover and ring gear are aligned. Assemble the eight 5/16-18x1 inch hex head bolts. Torque bolts to 20-25 (27.1-33.9 Nm) pound feet.

STEP 13

Assemble the disengage cover (28) with dimpled center protruding out if wheel is to be used to drive the vehicle. Assemble and torque the two 5/16-18x3/4 inch bolts. Torque bolts to 10-20 (13.6-27.1 Nm) pound feet.

STEP 14

Invert the Power Wheel assembly and assemble the coupling (1) with counterbore out to the input shaft.

CARRIER ASSEMBLIES

The primary and secondary carriers (sub-assemblies) must be serviced in their entirety to protect the integrity of the power wheel.

LUBRICATION RECOMMENDATIONS

Observe lubrication recommendations given by the original equipment manufacturer. When specific recommendations are not available, use mild extreme pressure lubricant API-GL-5, No. 80 or 90 for filling the Power Wheel under normal temperature ranges between 0-120°F (-18 to 49°C). Fill until oil just begins to flow from fill plug. Fill and drain plug is same. Cover to be positioned horizontal when filling.

SPECIFICATIONS

Approximate Weight	95 lbs. (43.1 Kg)
Oil Capacity	30 oz. (885 ml)

RTV SEALING COMPOUND

Silastic RTV 732 sealer and General Electric Silimate RTV No. 1473 are currently recommended for sealing gasket surfaces.

The RTV should be applied in a continuous bead, which should be centered on the surface to be sealed but should move to the inside of the hole at each bolt hole location.

TOWING VEHICLE

Caution: The power wheel will not normally be damaged by towing; however, the hydraulic drive components may be damaged unless the power wheel is disengaged from the drive motor. Road speeds in excess of 25 MPH should be avoided unless clearly specified to be permissible by the equipment manufacturer.

TO DISENGAGE POWER WHEEL

To disconnect the wheel from the input shaft, assemble the disengage cover (28) with the dimpled center protruding inward.

STORAGE

CAUTION: Finished surfaces must be protected to prevent rust when units are to be stored for extended periods.

*Reflects bead location in "RTV Sealing Compound" section.

6W83





Electrical System

Table of Contents

SPECIFICATIONS	1	Warning and Safety Circuits - Test Mode	8
SCHEMATICS (S/N 60001 - 80100)	2	Warning and Safety Circuits - Alert Mode	9
Key Off - Shutdown	2	Warning and Safety Circuits -	
Engine Crank and Start Circuit	3	Engine Shutdown	10
Engine Run - Critical Circuits Only	4	Warning and Safety Circuits -	
Engine Run - Circuits Made While Mowing	5	Engine Shutdown (Delayed)	11
Typical Run Mode - All Functions Normal	6	SCHEMATIC (S/N 80101 - 09999)	12
Warning and Safety Circuits - While Running ...	7	SCHEMATIC (S/N 10001 & UP)	13

Specifications

Electrical System: 12 volt, negative ground system.
BCI Group 48 battery, 440 cold cranking amps @ 0° F,
66 amp hour (DIN). 35 amp alternator.

Schematics (S/N 60001 - 80100)

KEY POSITION	CONNECTION MADE
1 OFF	NONE
2 RUN	B+I-A X-Y
3 START	B+I-S

Highlighted Lines Indicate 12 Volts

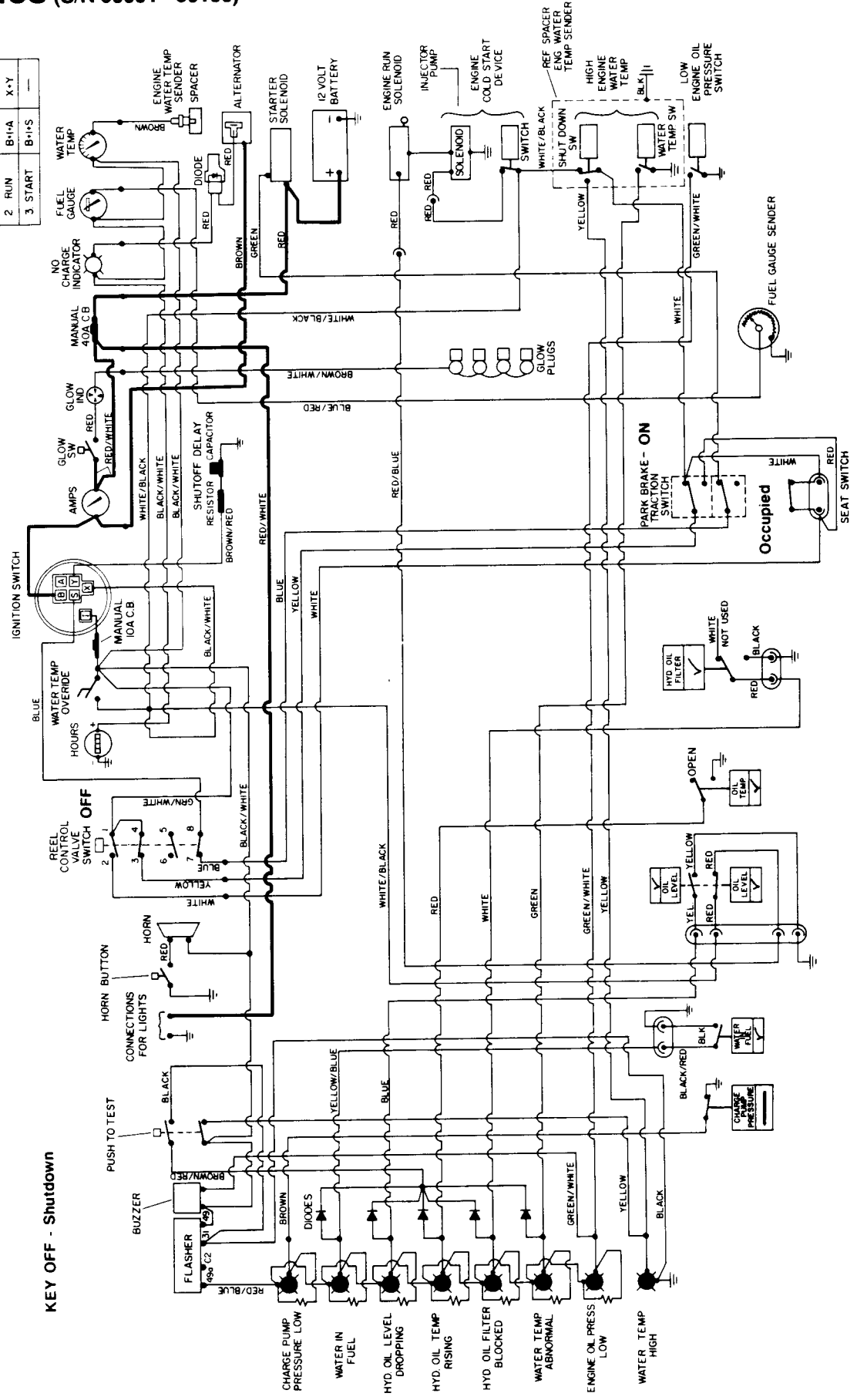

KEY OFF - Shutdown

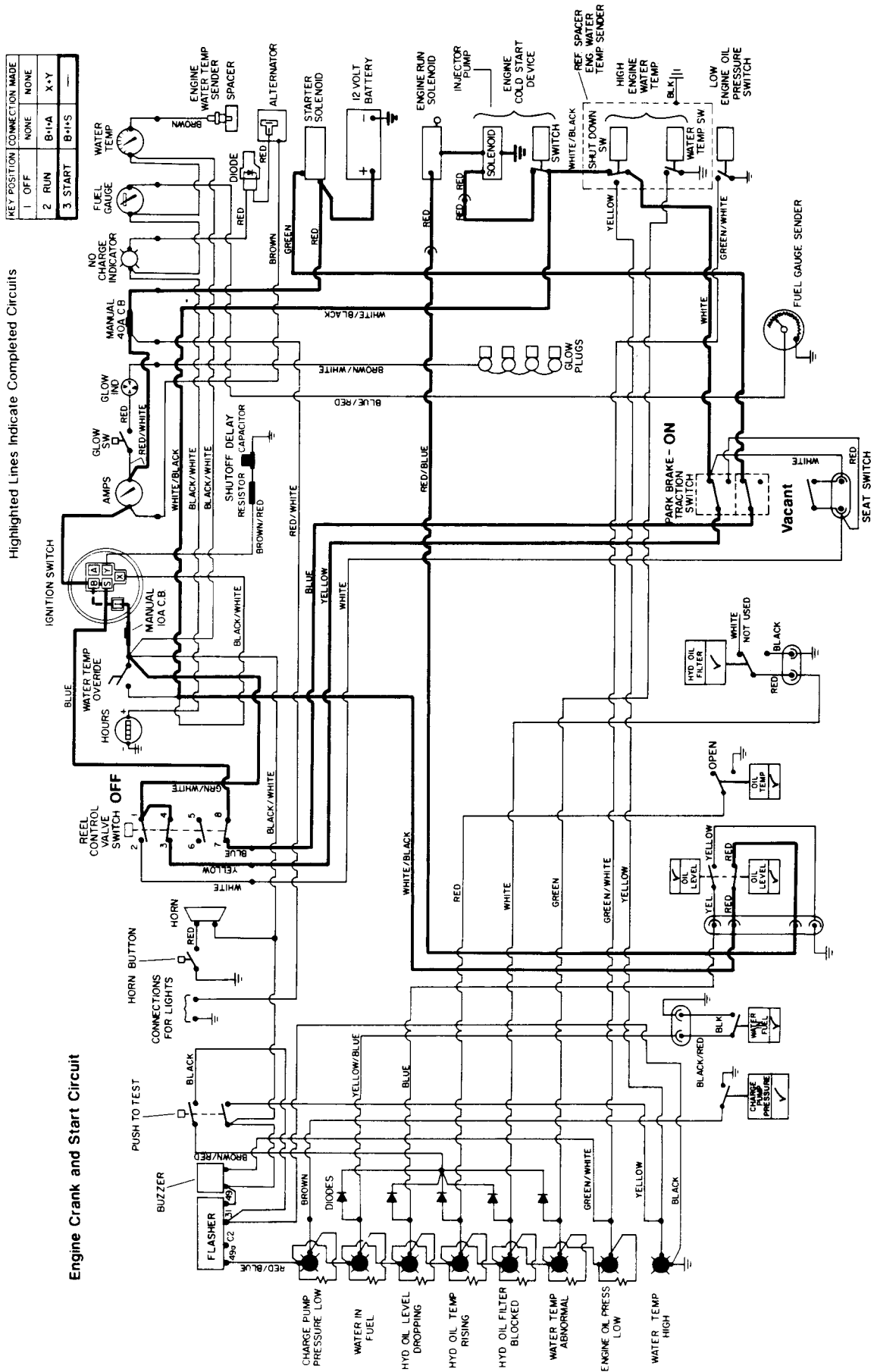

Highlighted Lines Indicate Completed Circuits

KEY POSITION	CONNECTION MADE
1 OFF	NONE
2 RUN	B-I-A X-Y
3 START	B-I-S

Engine Run - Circuits White Mowing

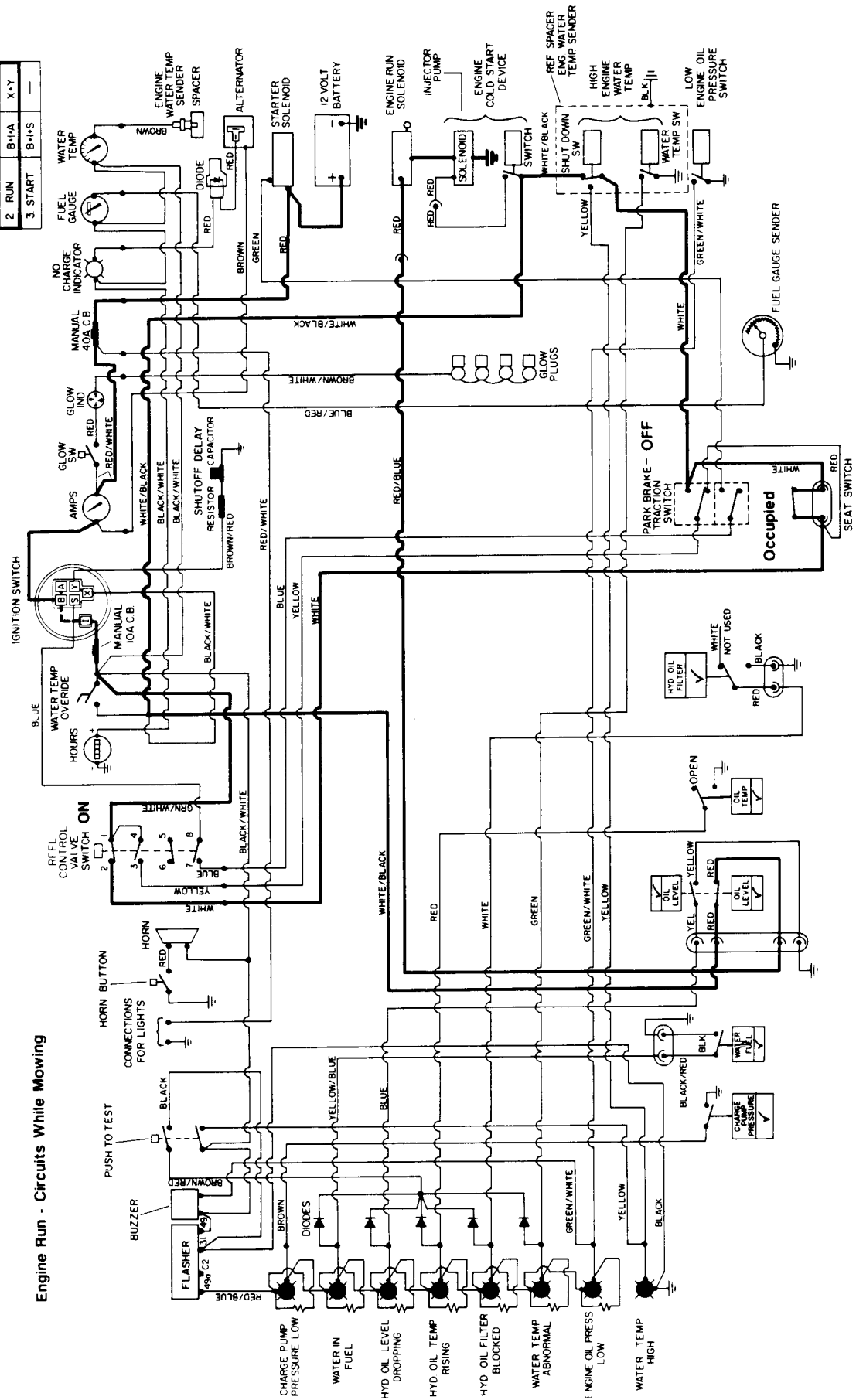

Engine Run - Circuits White Mowing

KEY POSITION	CONNECTION MADE
1. OFF	NONE
2. RUN	B-I-A
3. START	B-I-S

Highlighted Lines Indicate 12 Volts

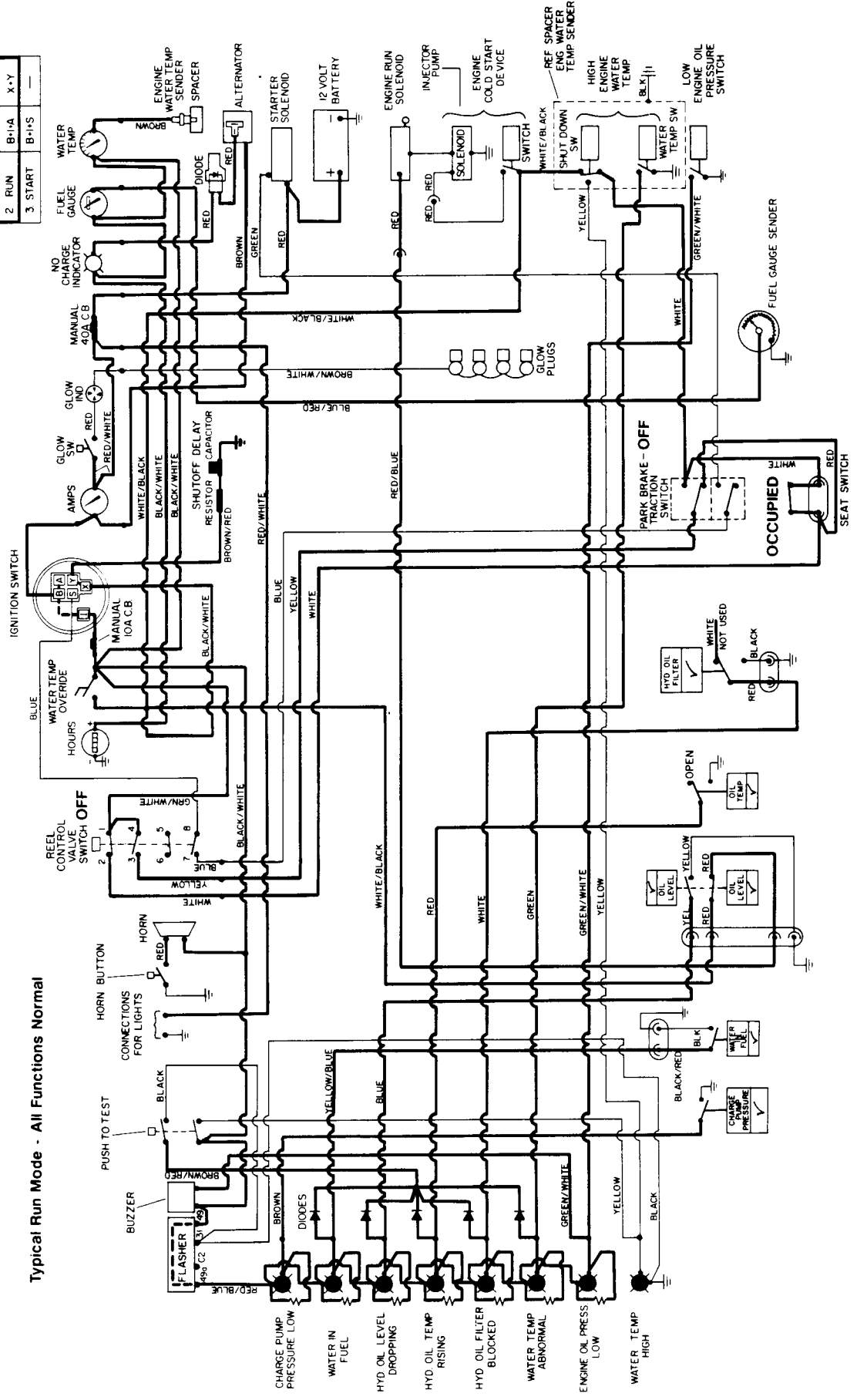

Typical Run Mode - All Functions Normal

KEY POSITION	CONNECTION MADE
1 OFF	NONE
2 RUN	B+1-A X-Y
3 START	B+1-S

Highlighted lines indicate 12 Volts

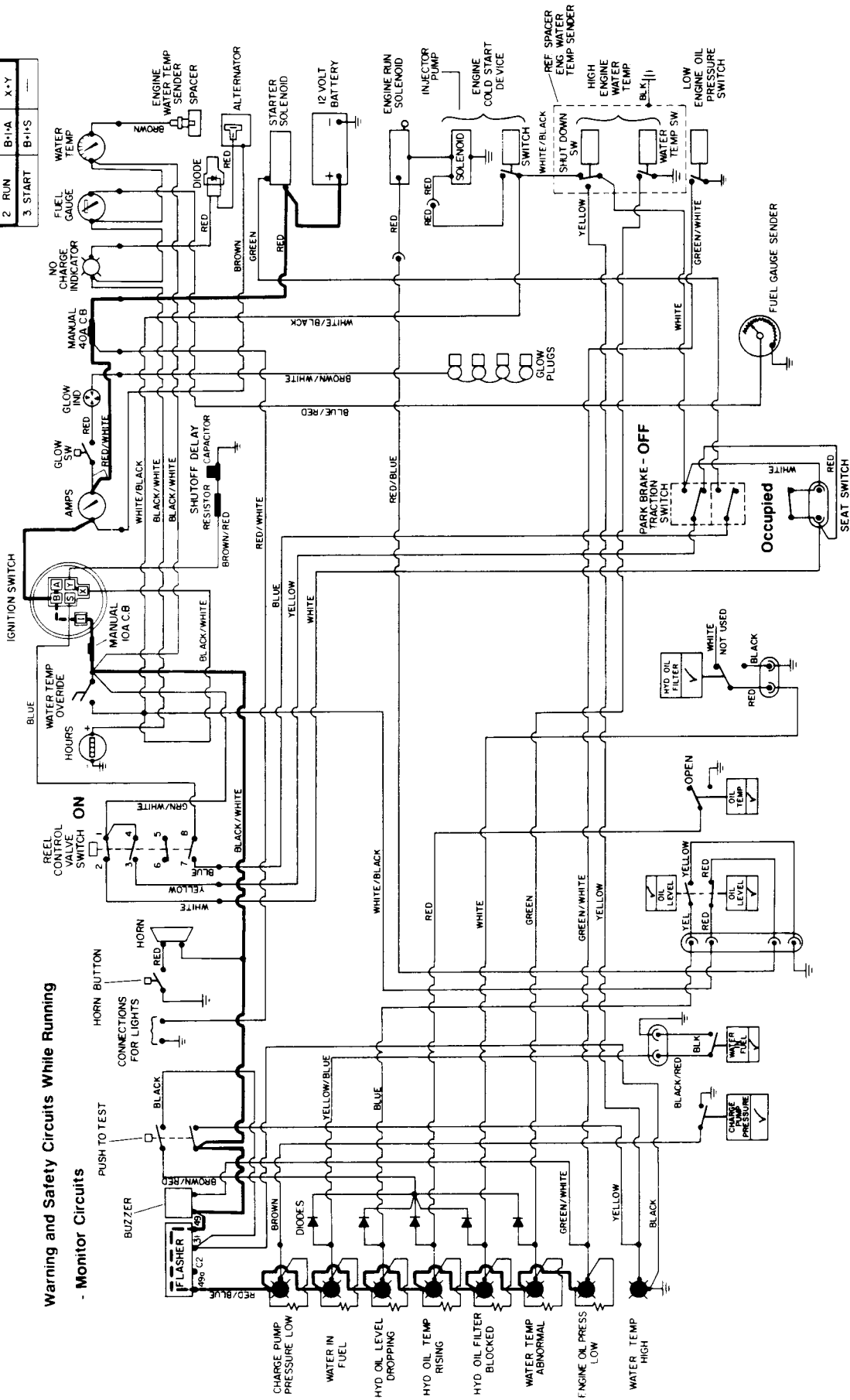

KEY POSITION	CONNECTION MADE
1 OFF	NONE
2 RUN	B+V
3 START	B+V

Highlighted Lines Indicate Completed Circuits

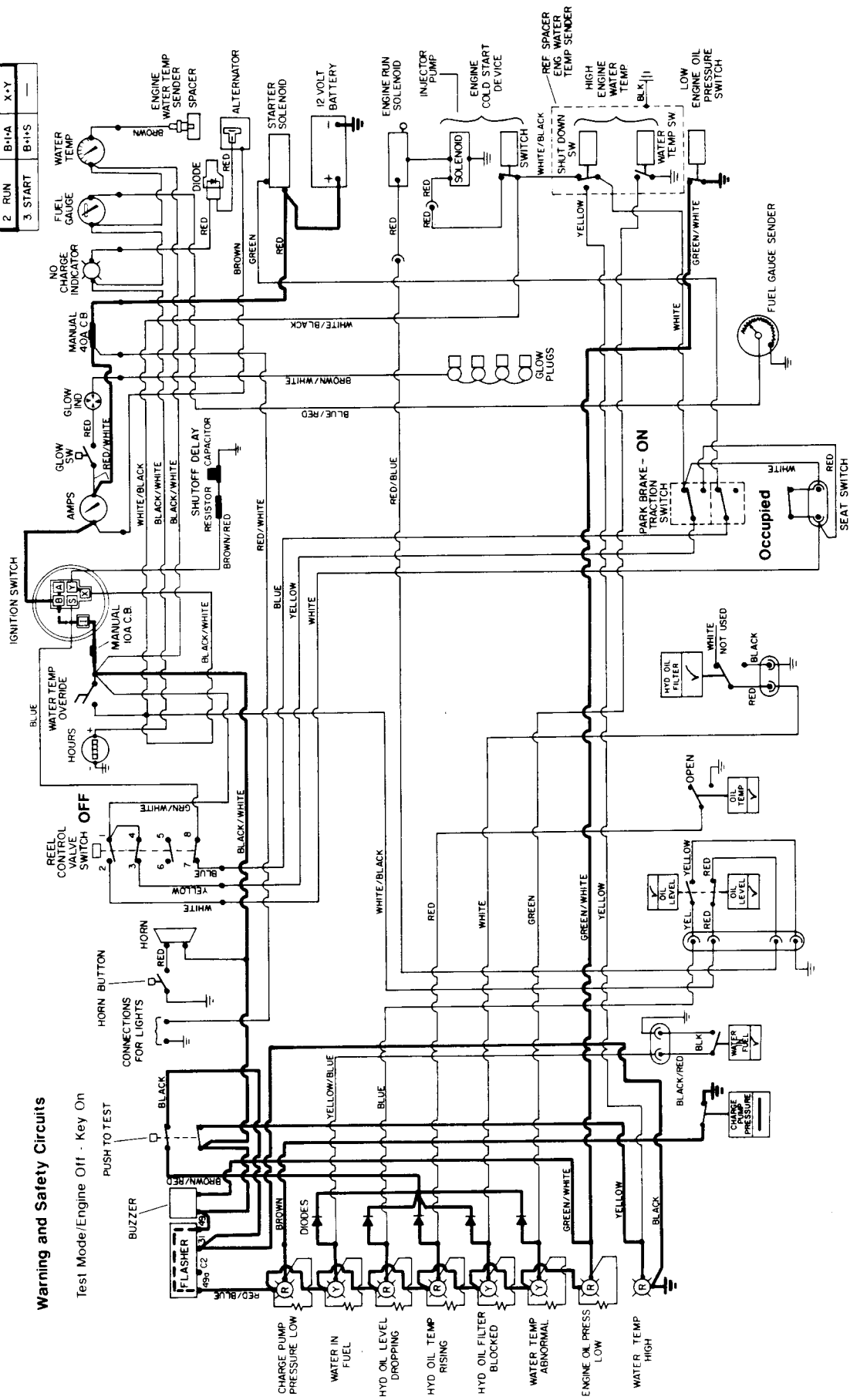

Warning and Safety Circuits
 Test Mode/Engine Off - Key On
 PUSH TO TEST

KEY POSITION	CONNECTION MADE
1 OFF	NONE
2 RUN	B-1-A X-Y
3 START	B-1-S

Highlighted Lines Indicate Completed Circuits

Warning and Safety Circuits

Typical Alert Mode

- 1 Low Hydraulic Oil Level
- 2 Hydraulic Oil Filter Blocked

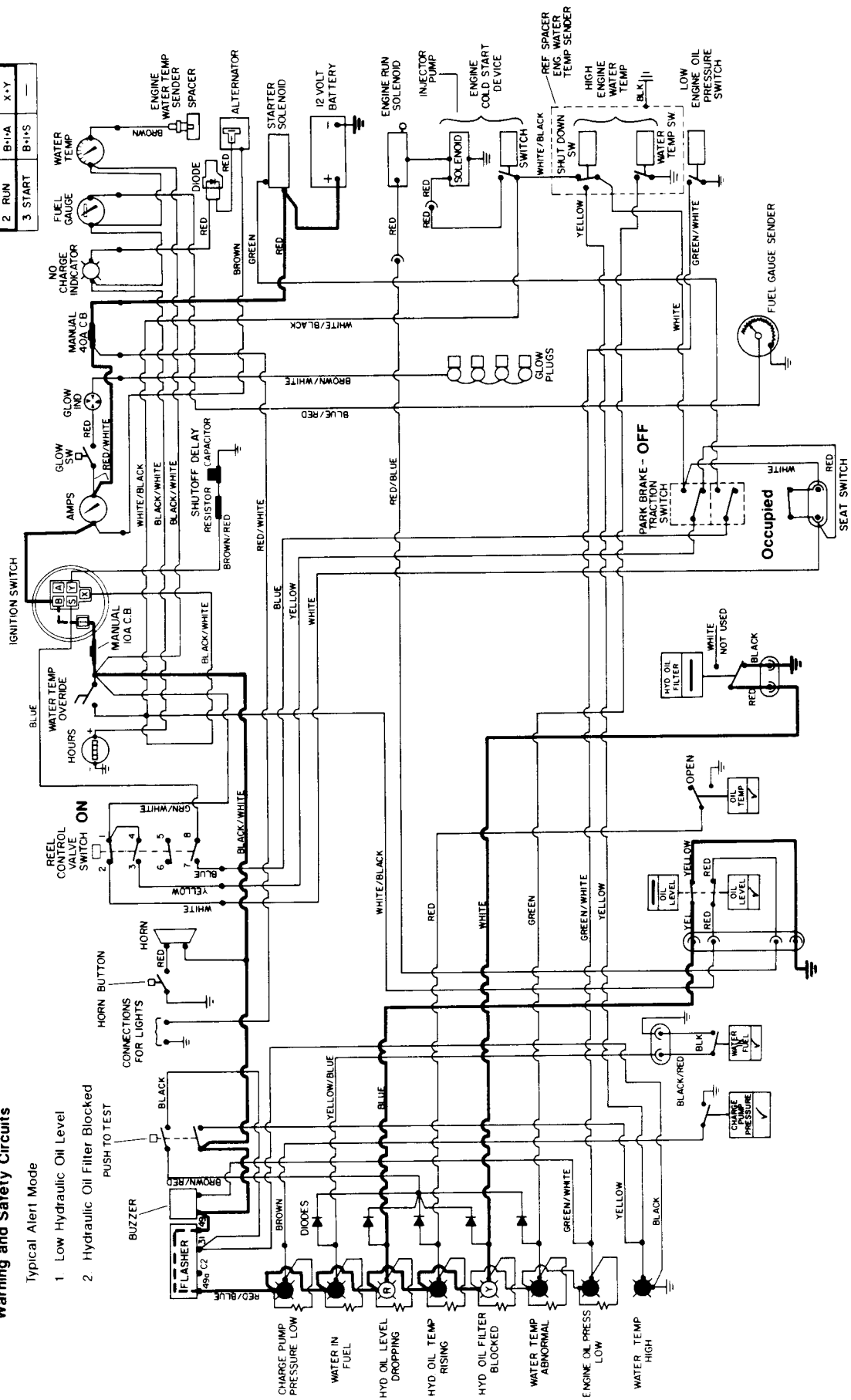

KEY POSITION	CONNECTION MADE
1 OFF	NONE
2 RUN	B+1-A X-Y
3 START	B+1-S

Highlighted Lines Indicate Completed Circuits

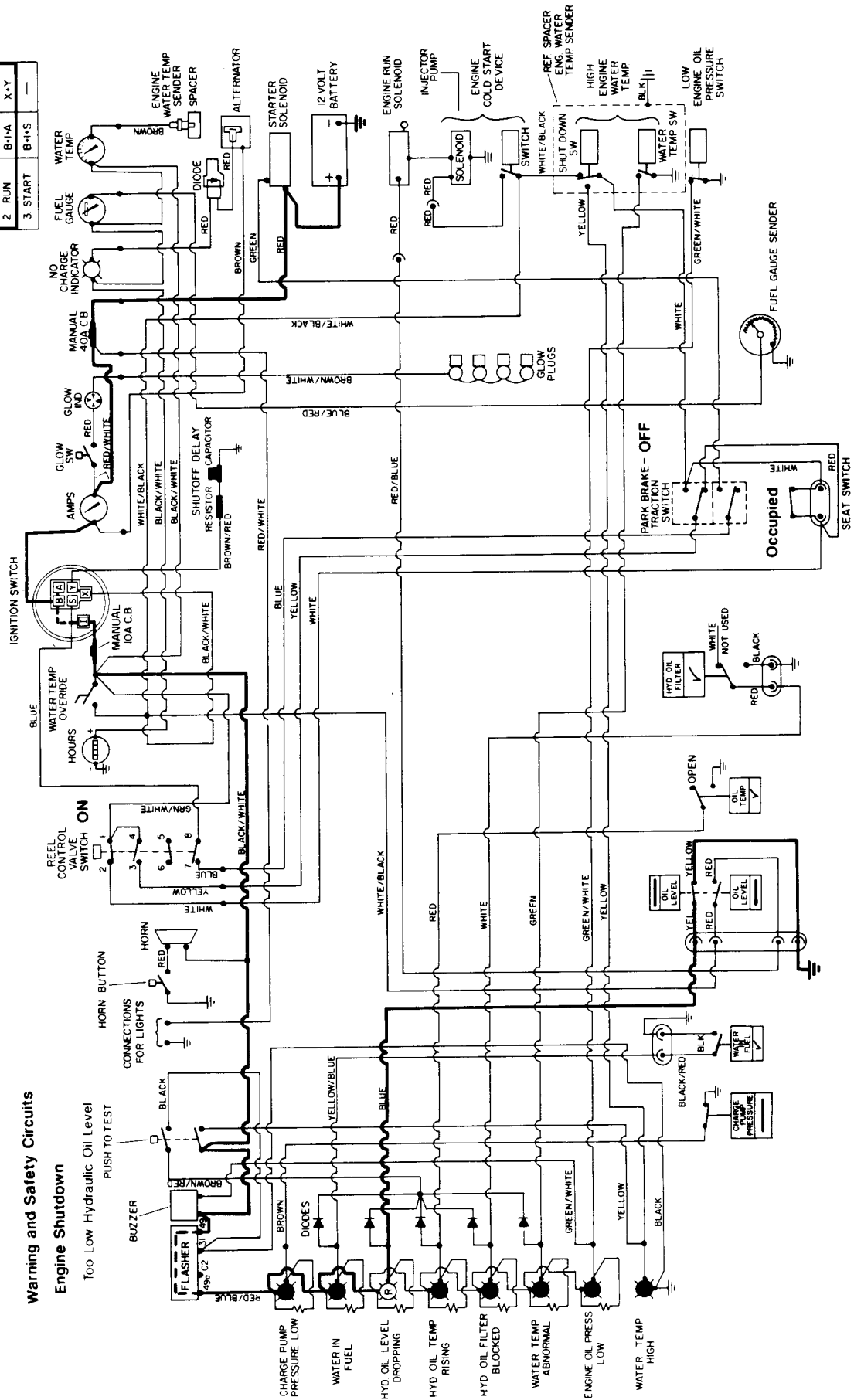

Warning and Safety Circuits

Engine Shutdown

Too Low Hydraulic Oil Level

PUSH TO TEST

Buzzer

Flasher

49% C2

RED/BLK

CHARGE PUMP PRESSURE LOW

WATER IN FUEL

HYD OIL LEVEL DROPPING

HYD OIL TEMP RISING

HYD OIL FILTER BLOCKED

WATER TEMP ABNORMAL

ENGINE OIL PRESS LOW

WATER TEMP HIGH

CHARGE PUMP PRESSURE

WHITE/FUEL

BLACK/RED

BLK

YELLOW

GREEN/WHITE

GREEN

WHITE

RED

WHITE/BLACK

WHITE

YELLOW

GREEN/WHITE

YELLOW

RED

RED

RED

YELLOW

GREEN/WHITE

GREEN

WHITE

RED

RED

WHITE

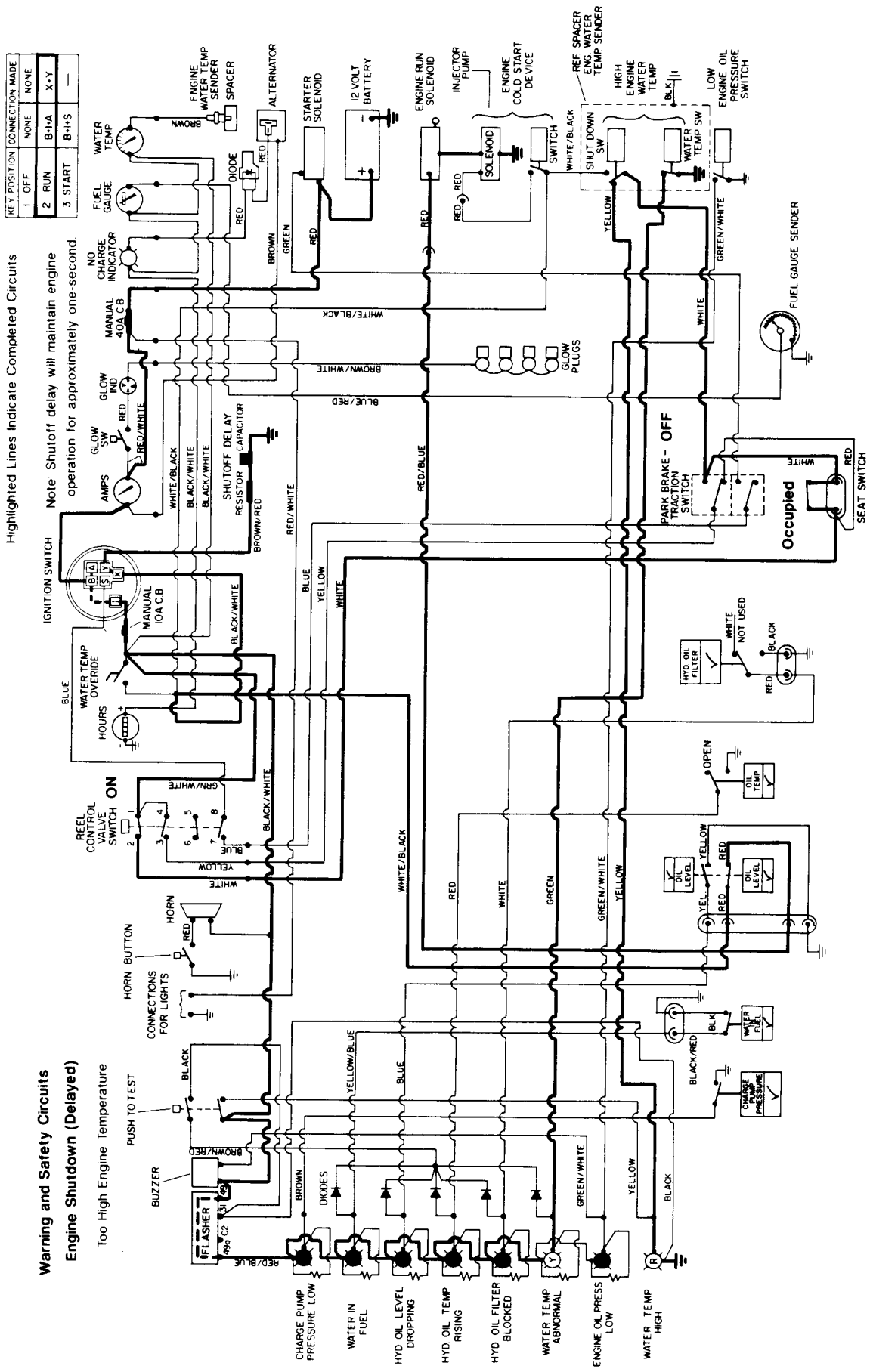

Highlighted Lines Indicate Completed Circuits

Warning and Safety Circuits
Engine Shutdown (Delayed)

Too High Engine Temperature

Note: Shutoff delay will maintain engine operation for approximately one-second.

Schematic (S/N 80101 - 09999)

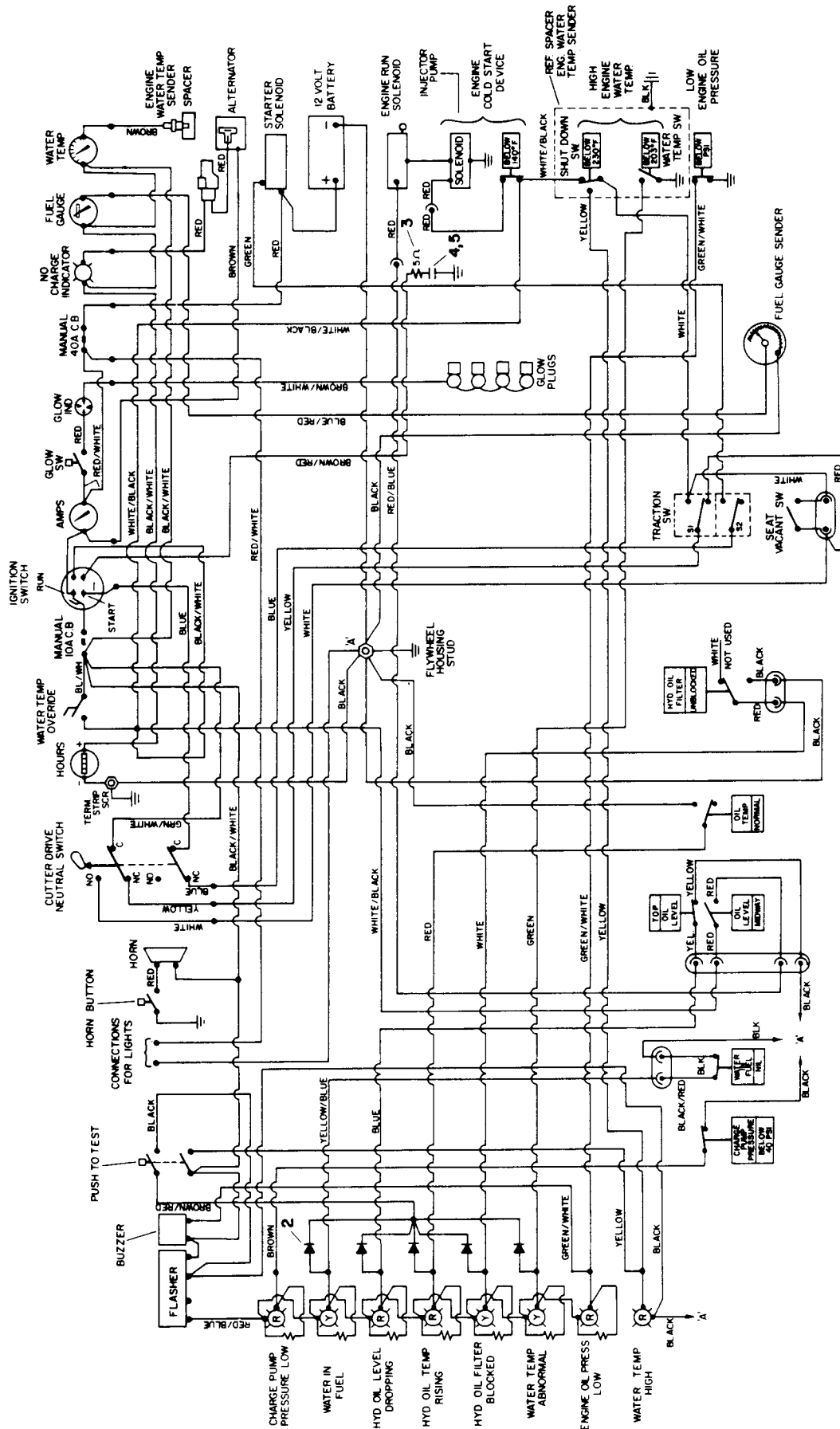

Schematic (S/N 10001 & UP)

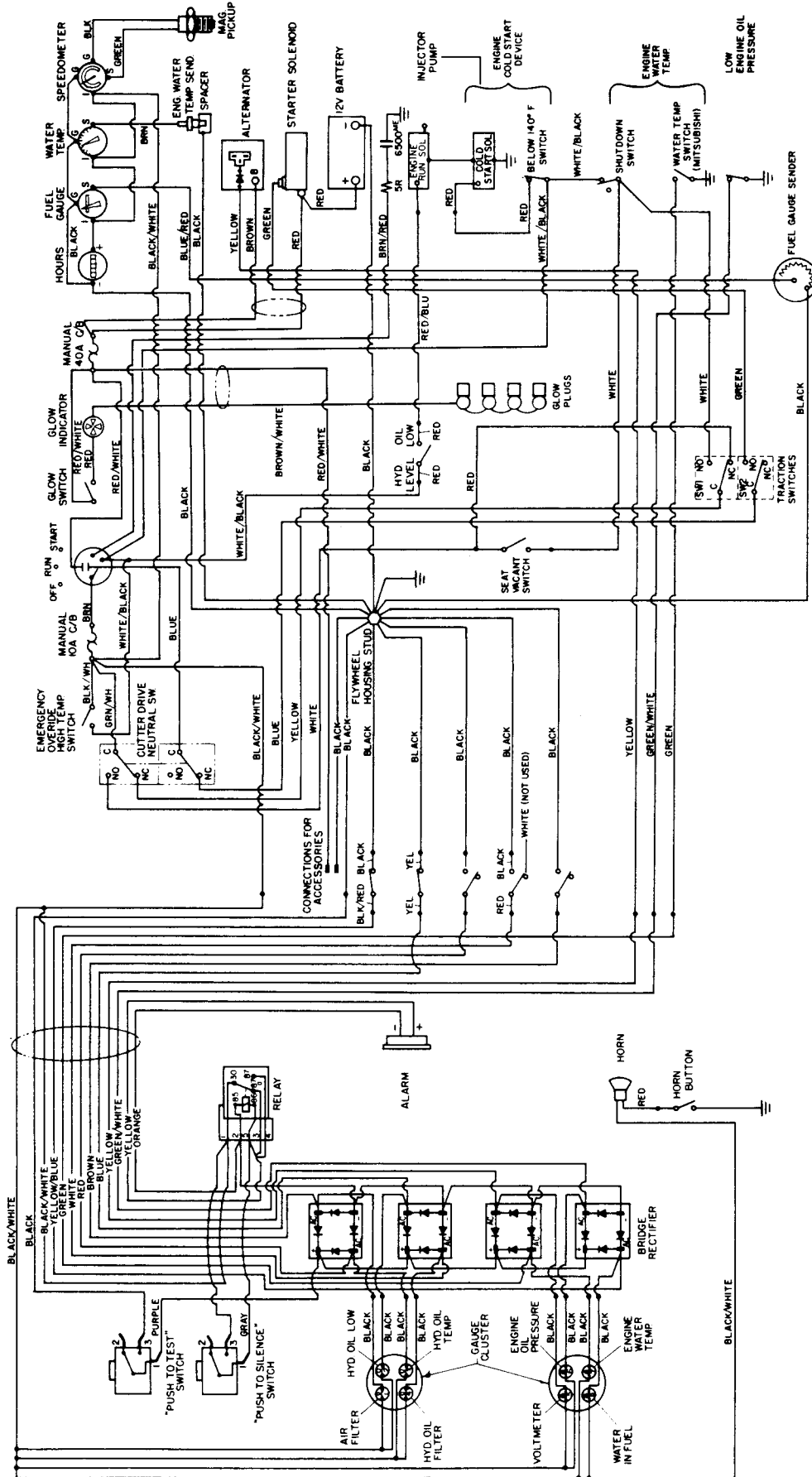

This page is blank.



Table of Contents

SPECIFICATIONS	2	REPAIRS	9
SPECIAL TOOLS	3	Backlapping	9
ADJUSTMENTS	5	Hydraulic Motor Installation	10
Adjusting Reel to Bedknife Contact	5	Servicing the Bedknife/Bedbar Assembly	12
Height of Cut Adjustment (Floating Cutting Unit) .	6	Servicing the Reel Assembly	13
Quick Method for Changing Height of Cut		Roller Removal and Installation	16
After Initial Set Up of a Floating Cutting Unit ...	8		
Height of Cut Adjustment (Fixed Cutting Unit) ...	8		
Adjusting Skids and Front Roller			
(Fixed Head Cutting Unit)	8		

Specifications

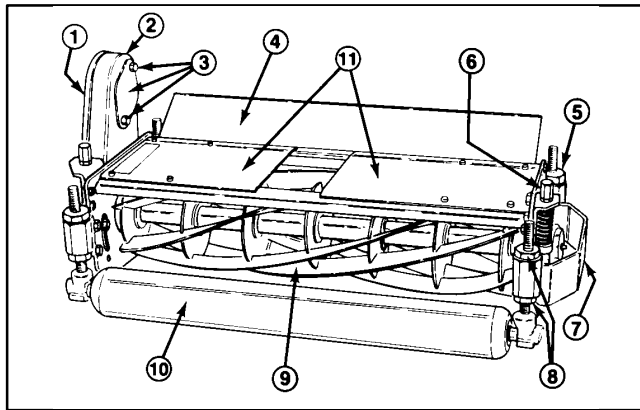

Figure 1

- | | |
|--|--|
| 1. Drive housing cover | 6. Reel to bedknife adjusting assembly |
| 2. Drive housing | 7. Guard |
| 3. Reel motor fasteners, drive plate shield and shipping cover | 8. Cone nut |
| 4. Grass deflector | 9. Reel assembly |
| 5. Rear roller adjusting assembly | 10. Front roller (optional) |
| | 11. Top covers |

Construction: Welded steel frame and reel with heavy duty, self-aligning ball bearings. Heavy duty steel rear roller with tapered roller bearings. Rear roller and bedbar are isolated and mounted in rubber bushings for quiet, vibration-free operation. Adjustable deflector shields are standard. Stainless steel components are used at key points for added durability.

Reel Configuration: The 5, 7 and 11 blade heavy duty welded reels all have 8 in. (20.3 cm) diameters and are 29-3/4 in. (75.5 cm) wide.

Bedknife/Bedbar Assembly: A replaceable, single edged, alloy steel bedbar is induction hardened. It's fastened with steel screws to a precision ground surface on the high strength, fabricated steel bedbar. The stress-relieved machined bedbar is mounted with four (4) vibration isolation bushings.

Bedknife to Reel Adjustment: Two lockable lead screw adjusters at each side of the frame adjust the reel to bedknife contact.

Rear Roller: 3-1/2 in. (89 mm) diameter steel roller has greaseable tapered roller bearings. A double lip oil seal and wear sleeve isolates grit and moisture from the bearings.

Height-of-Cut: 5 Blade – 1 to 3 in. (25 to 76 mm). 7 Blade – 1/2 to 1-3/4 in. (9.5 to 45 mm). 11 Blade – 3/8 to 3/4 in. (9.5 to 19 mm).

Height-of-Cut Adjustment: Quick adjustment and positive locking is provided by locking type cone nuts. Gauge marks of 1/4 in. (6.3 mm) are provided as a reference for easy changes of height-of-cut.

Clip (variable to match cutting conditions):

5 Blade Cutting Unit: .176 in. per mph
(.352 in. at 2 mph – 1.32 in. at 7.5 mph)

7 Blade Cutting Unit: .126 in. per mph
(.252 in. at 2 mph – .945 in. at 7.5 mph)

11 Blade Cutting Unit: .080 in. per mph
(.16 in. at 2 mph – .600 in. at 7.5 mph)

Lubrication: Easily accessible grease fittings for bearings and all major pivot points.

Drive: The reel drive motor turns a maintenance-free cog belt which drives the reel. Drive pulley and cog belt are encased in a drive housing for safety and protection from contamination.

Grass Deflector Shields: Fully Adjustable.

Special Tools

Order special tools from the *TORO SPECIAL TOOLS AND APPLICATIONS GUIDE (COMMERCIAL PRODUCTS)*. Some tools may be listed in the Reelmaster

4500–D Parts Catalog. Some tools may also be available from a local supplier.

Gauge Bar Assembly

Use gauge bar to set final height of cut (floating cutting unit with front roller only).

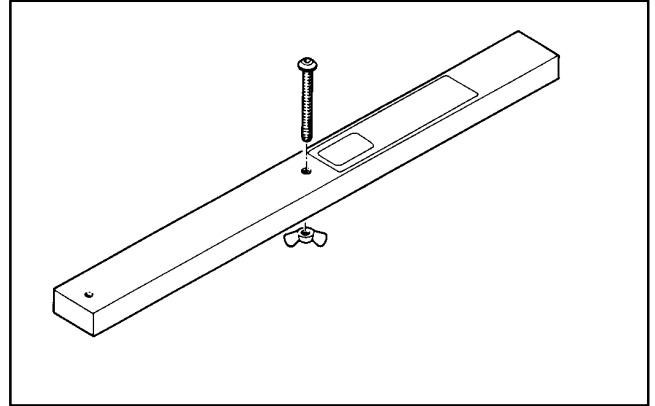

Figure 2

Handle Assembly

For applying lapping compound to cutting units while keep hands a safe distance from the rotating reel.

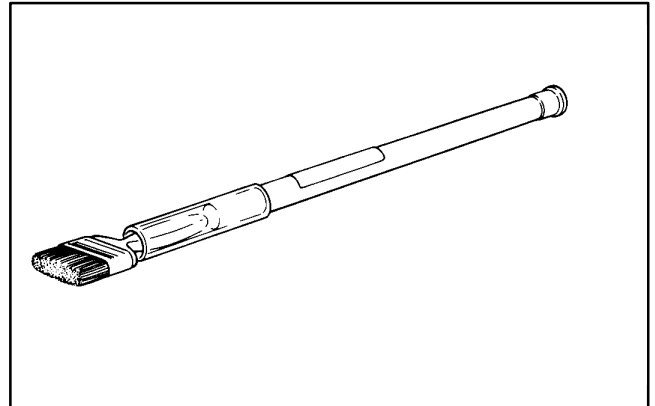

Figure 3

Bedknife Screw Tool

Fits Toro bedknife attaching screws. Use with torque wrench to secure bedknife to bedbar. With clean bedbar threads and new screws, tighten to a torque of 250 in-lb.

NOTE: Remove all rust, scale and corrosion from bedbar surface before installing bedknife.

DO NOT use an air impact wrench with this tool.

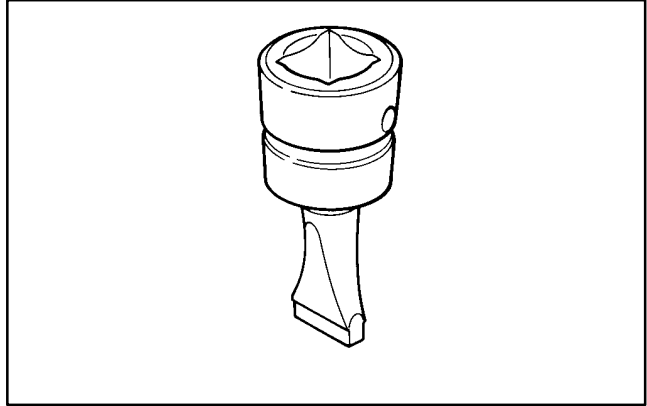

Figure 4

Adjustments



CAUTION

Never install or work on the cutting units or lift arms with the traction unit engine running. Always stop the engine and remove the key first.

Adjusting Reel to Bedknife Contact

Before adjusting height-of-cut and each day before operating, check reel to bedknife contact, regardless if quality of cut had previously been acceptable.

NOTE: A 3/4" wrench is required for making the reel to bedknife adjustment.

A. Slowly and carefully rotate reel, listening for light contact across the full length of the reel and bedknife.



CAUTION

Before adjusting reel to bedknife, raise and fully latch cutting units. Remove key from the ignition switch. Keep others off machine while adjusting cutting units.

B. If no contact – loosen the adjuster locking nut on each adjuster (Fig. 5). Then, equally turn each adjuster knob clockwise until light contact is felt and heard.

C. If excessive contact – Turn the adjusting knobs counter-clockwise until no contact is noticed. Then equally turn both adjusting knobs clockwise, until light contact is felt and heard between the reel and bedknife. Final adjustment should always be in the tightening (clockwise) direction.

D. Tighten adjuster locking nuts when completed making adjustments.



CAUTION

When adjusting the cutting units, wear heavy gloves and use care when turning reels by hand. Sharp edges can cut or pinch hands or fingers.

IMPORTANT: Adjusted correctly, the reel will cut paper (approx. .003" thick) across its entire length.

The cutting units will provide optimum mowing performance when adjusted and maintained correctly. Keeping a precise reel to bedknife adjustment (light contact), at each end of the cutting unit will produce a continual self-sharpening action. Therefore, sharp cutting edges are maintained, good quality of cut assured, and the need for corrective re-sharpening reduced.

IMPORTANT: Cutting units with excessive contact between the reel and bedknife are noisy, consume excessive power, shorten component life and result in overall poor performance. Light contact between the reel and bedknife, once the cutting unit is warmed up, provides optimum mowing performance and component life.

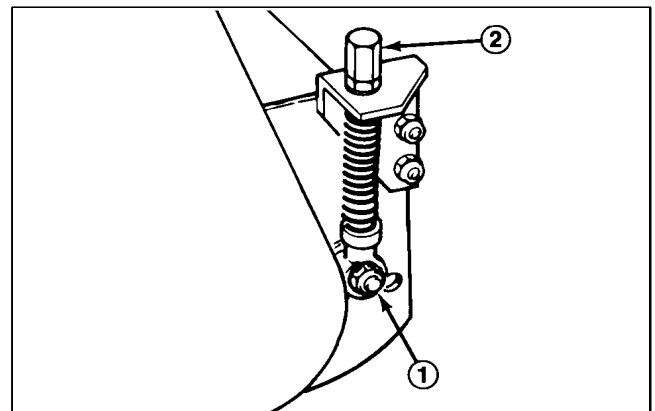

Figure 5

- 1. Adjuster locking nut
- 2. Adjustment knob

Height-of-Cut Adjustment (Floating Cutting Unit)

Overview of Procedure:

1. Adjust reel to bedknife contact
2. Level rear roller to reel
3. Final height-of-cut adjustment using gauge bar.

STEP 1 – Adjust Reel to Bedknife Contact

- A. Adjust reel to bedknife contact on all cutting units. (Refer to Adjusting Reel To Bedknife Contact).

STEP 2 – Level Rear Roller to Reel

- B. Start engine and lower the cutting units onto a flat surface such as a piece of 3/4" or 1" plywood (at least 20" x 30" in size). Stop engine and remove key from switch. Lock cutting units in the fixed position, by loosening the jam nut on lockout pin (Fig. 6) and screwing pin into hole in pivot arm (Fig. 7). Tighten nut to secure lockout. Raise the front rollers up so they do not contact the flat surface.

- C. Insert a piece of bar stock 25" – 28" (70 cm) long (Fig. 8), and approximately 3/8" (9.5 mm) thicker than the desired height-of-cut, under the reel and up against the bedknife cutting edge (Fig. 8). The reel (not bedknife) must contact the bar stock along its full length.

NOTE: Using a bar 3/8" (9.5 mm) thicker than height-of-cut provides proper bedknife attitude (heeled "up" in back) required for excellent low height-of-cut performance.

- D. Loosen rear roller jam nuts and adjusting knobs and push roller down against flat surface. At this point the reel should be contacting the bar stock and the rear roller contacting the flat surface. Contact should exist along the entire length of the reel and rear roller. Tighten rear roller adjusting knobs and jam nuts. Recheck to be sure roller and reel are both still making contact after jam nuts have been tightened. Check roller contact by trying to slide paper between the roller and the flat surface.

- E. Rear roller is now leveled to the reel.

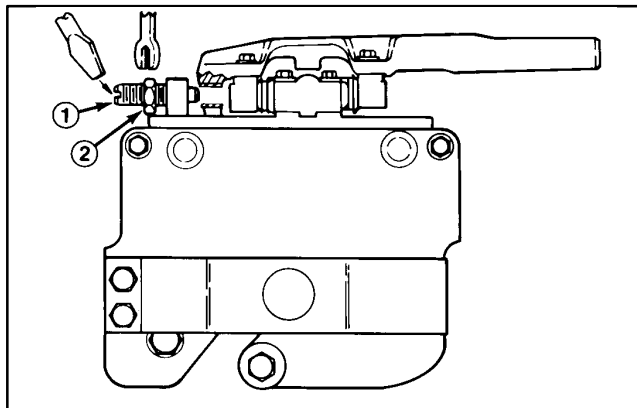

Figure 6
Cutting Unit Float Position

1. Lockouts 2. Jam nut

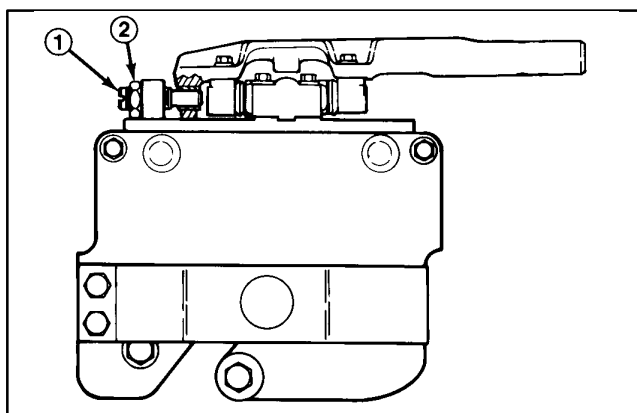

Figure 7
Cutting Unit Fixed Position

1. Lockout pin 2. Jam nut

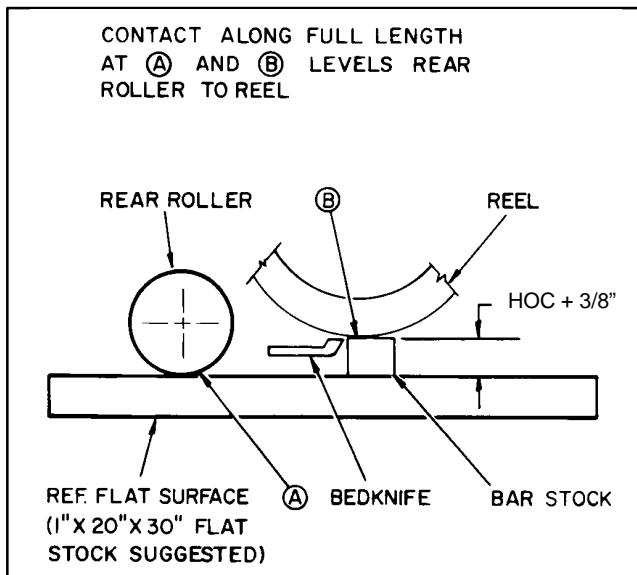

Figure 8
Leveling Rear Roller to Reel

STEP 3 – Final Height-of-Cut Adjustment Using Gauge Bar

F. Raise cutting units and lock in the transport position. Shut off the engine and remove the key.

G. Use gauge bar (Toro Part No. 59-7900) to set final height-of-cut by adjusting front roller only.

H. Loosen the gauge bar jam nut and adjust the screw to set dimension between underside of screw head and gauge bar for desired height-of-cut (Fig. 9). Tighten the jam nut to secure the adjustment. Hook screw head over cutting edge of bedknife and position bar against bottom of front roller (Fig. 10).

I. Loosen front roller nuts and adjust both ends of the front roller until it contacts gauge bar at both ends. With the gauge bar held firmly against the bottom of the rollers adjust the front roller so the screw head just slips over the lip of the bedknife (Fig. 10). Tighten front roller nuts.

IMPORTANT: Set properly, front and rear rollers will contact gauge bar and screw head will be snug over bedknife cutting edge when checked at both ends of the reel.

J. Loosen lockout pin so cutting unit can float freely (Fig. 6).

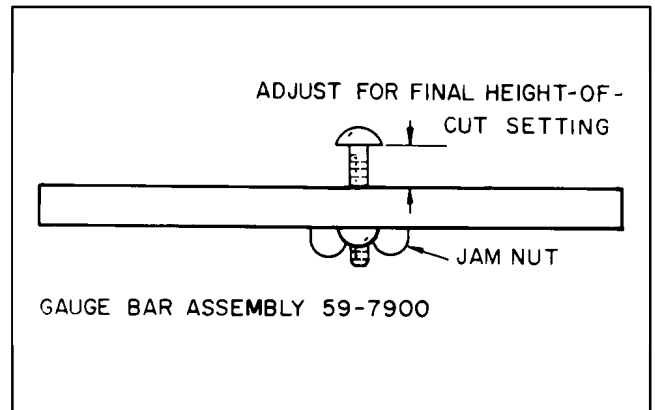

Figure 9
Gauge Bar Assembly

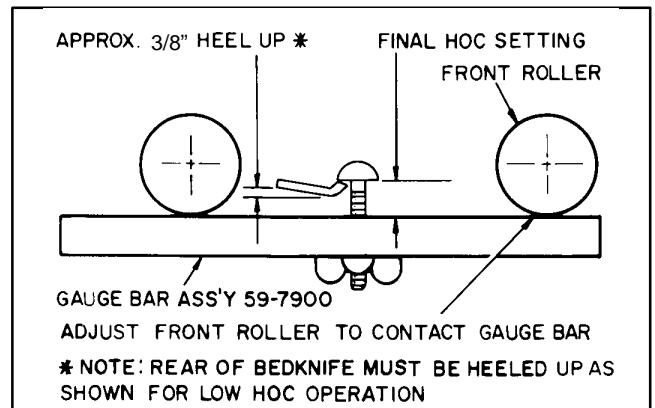

Figure 10
Final Height-of-Cut Adjustment Using Gauge Bar

Quick Method For Changing Height-of-Cut After Initial Set Up of a Floating Cutting Unit

If the reel to bedknife adjustment has been set (STEP 1) and the rear roller leveled to the reel (STEP 2), the cutting unit may be quickly changed from one height-of-cut to another by using the gauge bar (Part #59-7900) and adjusting the front roller only. In many cases, an entire machine can be done quickly by using the gauge bar

to set the front roller of one cutting unit. The remaining cutting units can then be set by loosening their front roller jam nuts and turning each front roller adjustment knob the same number of turns and in the same direction as the first unit.

Height-of-Cut Adjustment (Fixed Cutting Unit)

1. Adjust reel to bedknife contact.
2. Loosen nuts securing skids or front roller and raise to highest position.
3. Loosen jam nuts securing rear roller. Lower roller beyond desired height-of-cut (assures proper bedknife attitude).
4. Lower cutting unit onto a flat surface, such as a 1" x 20" x 30" piece of plywood. Shut off engine and remove the key.
5. Insert piece of bar stock (Fig. 11) 25"–28" (70 cm) long with thickness equal to desired height-of-cut, under entire length of the reel, next to bedknife.
6. Adjust rear roller adjustment knobs and jam nuts until full length of the rear roller contacts the flat surface and the full length of the reel (not bedknife) contacts the bar stock. Tighten rear roller knobs and jam nuts.

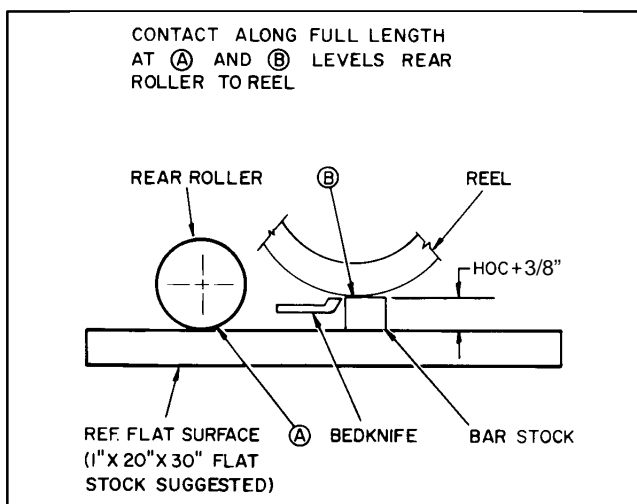

Figure 11

Adjusting Skids and Front Roller (Fixed Head Cutting Unit)

After skid kit or front rollers are installed (installation instructions are included with each option) make the following adjustments to prevent them from pushing down uncut grass or scalping on undulating terrain:

1. Lock each cutting unit in the fixed position (Refer to Cutting Unit Orientation, Fig. 15. Set the reel to bedknife adjustment and height-of-cut adjustment.
2. Position the cutting units on a flat, level surface (a 1" inch (25 mm) thick piece of plywood is ideal).

3. Skids and front rollers used to prevent scalping should not ride on the ground. Adjust each skid or front roller so it is 1/8 – 1/4 in. (3 – 6 mm) or higher above the level surface. Allow greater clearance at the higher height-of-cut settings.

4. Proper adjustment is achieved when the cutting unit does not scalp the grass in normal mowing conditions and yet is set high enough not to mar the turf and create undue wear on the skids or rollers.

NOTE: Skids are used only with the cutting unit in the fixed position. Front rollers may be used with the cutting unit in either the fixed or floating position.

Repairs



CAUTION

Never install or work on the cutting units or lift arms with the traction unit engine running. Always stop the engine and remove the key first.

Backlapping



CAUTION

DURING BACKLAP OPERATION REELS ARE UNDER POWER. CONTACT WITH ROTATING REELS CAN RESULT IN PERSONAL INJURY. DO NOT ADJUST CUTTING UNITS WHILE ENGINE AND REELS ARE OPERATING. INSTRUCT OPERATOR TO STOP THE REELS AND SHUT THE ENGINE OFF WHEN ADJUSTMENT IS NECESSARY.

Use a good grade of medium grit (80 coarseness) lapping compound with a water soluble carrier so the compound will be easily washed away after completion of the operation. Dry lapping compound should be mixed with liquid detergent until it has a free-flowing consistency.

Two people are required to perform backlapping. Good communication between one another is necessary and caution should be used when making each move. With one person on the seat to operate the controls (operator) the other performs the backlapping operation.

NOTE: Before starting the engine raise the grass deflector on the #1 cutting unit (center) and tighten fasteners to retain the deflector in the raised position.

1st persons duties (Operator):

- A. Sit on the seat and engage parking brake.
- B. Start the engine and run at minimum throttle. Lower either: 1.) the center cutting unit (#1) or 2.) the left hand (#2) cutting unit or 3.) the right hand (#3) cutting unit.

With the #2 & #3 cutting units up and latched (automatically shut off) and the #1 cutting unit down, backlap the center (#1) cutting unit from the rear of the machine with the long handled brush. Backlap

the #2 and #3 cutting units from the front of the machine.

C. Wait for 2nd person's instruction to engage reels in BACKLAP mode, then pull up on reel switch and move it to ENGAGE position.

D. Turn REEL SPEED KNOB counterclockwise to the BACKLAP position.

E. Follow 2nd person's instructions. Be prepared to stop reels and engine quickly in case of an emergency.

2nd persons duties:

- A. Instruct operator when to start and stop reels.



CAUTION

UNDER NO CIRCUMSTANCES USE A SHORT-HANDLED PAINT BRUSH TO APPLY BACKLAPPING COMPOUND. A ROTATING REEL CAN ACTUALLY PULL A SHORT HANDLED PAINT BRUSH AND THE USERS HAND INTO THE REEL CAUSING SERIOUS PERSONAL INJURY.

B. Dip 3 in. (76 mm) paint brush attached to Toro Part No. 29-9200 Handle Assembly into lapping compound. Stand clear and instruct operator to engage reel into backlap mode.

C. Apply lapping compound evenly over full length of the reel, assuring that all reel blades are covered. Whenever noise of reel against the bedknife begins to disappear or, an uneven concentration of material appears on the reel, redistribute the compound with the brush.

D. When it becomes necessary to adjust the reel to the bedknife, instruct the operator to disengage the reel, stop the engine and remove the key from the

ignition switch. Then proceed with the adjustment only after the reels have stopped rotating.

E. Backlap each reel until the cutting edges are sharp, even, and consistent on all blades. Achieve a minimum of 1/32 in. (0.79 mm) land area on newly sharpened reel assemblies. Normally, a reel need only be backlapped for approximately 3 minutes.

F. Upon completion, stop the reel and turn off the engine. Remove the key from the ignition switch. Wash the unit thoroughly with a low pressure stream of water to remove all lapping material. Allow the reel to dry and lubricate the grease fittings.

G. Check sharpness of the reel and bedknife with strips of newspaper. With light reel to bedknife contact, the paper should be cleanly sheared across the entire width of the reel. If the paper is not sheared acceptably, continue backlapping.

H. After backlapping the first cutting unit, raise and latch this unit and proceed with the #2 and #3 cutting units.

NOTE: See the Toro Sharpening Manual (Part No. 80300SL) for additional backlapping/sharpening information.

Hydraulic Motor Installation

1. Install the drive plate shield onto the reel drive motor flange (Fig. 12). Be sure the widest portion of the shield is at the top.

NOTE: Check to see that motor pulley set screws are tight on motor shaft before installing motor onto cutting unit (Fig. 13).

2. Insert the reel drive motor pulley through the housing and slip the cutting unit drive belt over the pulley (Fig. 13).

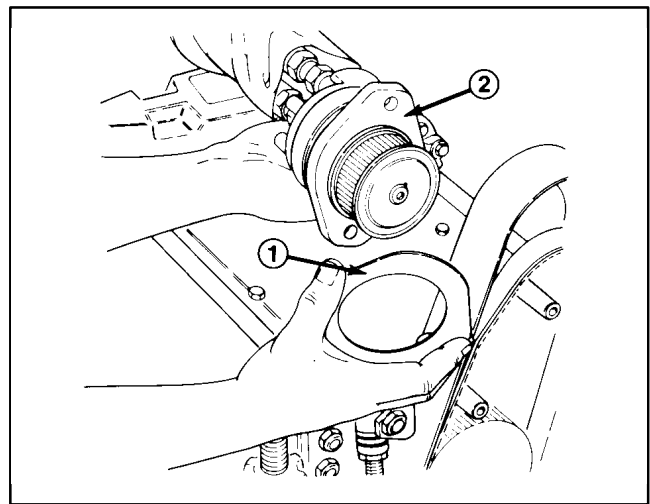

Figure 12

1. Drive plate shield 2. Reel drive motor flange

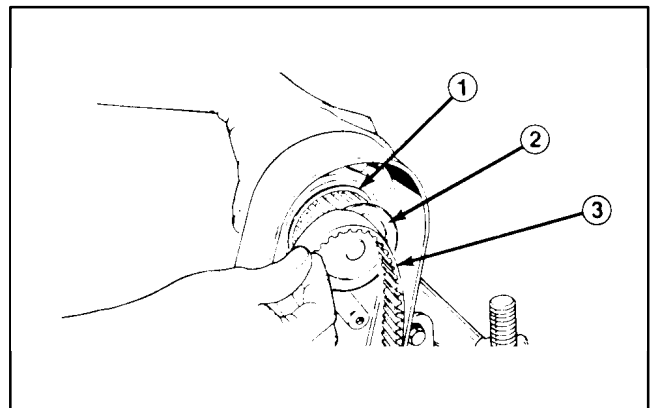

Figure 13

1. Hydraulic motor 2. Motor pulley
3. Drive belt

3. Insert the two (2) reel drive motor mounting bolts (heads on inside of the drive housing – flat washer on top bolt) through the reel motor flange holes. Thread the locknuts onto the bolts. Rotate reel motor upward in the slotted hole in the housing to tension the drive belt and tighten the fasteners (Fig. 14) to approx. 25 ft–lbs (34 Nm). NOTE: Proper belt tension is achieved when belt deflects approximately 1/8" (3 mm) at mid–point when 7 lbs. force is applied. (Fig. 14).

IMPORTANT: Rotate motors by hand only. Never place a bar between hose fittings on hydraulic motors – motor damage may result.

4. Install the gasket and drive housing cover after making sure the ends of the gasket are at the bottom of the housing to allow for drainage.

IMPORTANT: When hydraulic motors have been mounted to the cutting units make sure hydraulic hoses lay flat and do not contact the frame of the machine when the cutting units are in the raised position. There should also be sufficient slack SO hoses are above and not in contact with the floatation kit. If hoses appear twisted once the hydraulic motors have been mounted and the belts tightened, loosen swivel nuts at the motor and reposition hoses. This can greatly increase the life of the hoses. With cutting units down, all cutting unit hoses should have a flat natural lay and be free from twist.

NOTE: Refer to the Traction Unit Operator's Manual for instructions on setting the adjustable hydraulic counter-balance.

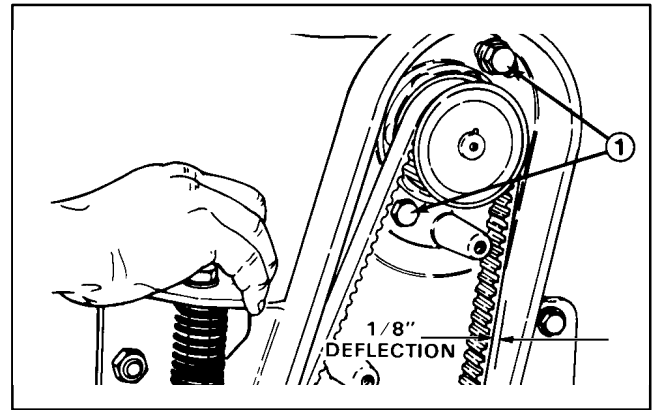

Figure 14

1. Reel motor fasteners

- 1. #3 Cutting unit
- 2. Hose bracket

Servicing the Bedknife/Bedbar Assembly

NOTE: The bedbar on each cutting unit has a precision ground mounting surface to provide an excellent fit with a bedknife. Backlapping of replacement bedknives is often sufficient to achieve an excellent cutting edge with minimum material removed.

Bedknife/Bedbar Removal:

1. Remove the shoulder bolts, bushings and spacers from each end of the unit and remove the bedbar/bedknife assembly (Fig. 16).

2. Remove the mounting screws for the bedknife and separate the bedknife from the bar (Fig. 17). Discard the screws.

Assembly:

1. Thoroughly clean the bedknife mounting face on the bedbar of all rust and scale. Remove any material on the mounting face of the bedbar that will affect a good match-up with the bedknife.

2. Before installation, apply a coating of "Never Seez", or any material that will ease future disassembly of the bedknife mounting screws, to the threads before installation.

3. Use a torque wrench and special bedknife screw tool to complete tightening of the screws (Fig. 18). Tighten the screws to a torque of 250 in.-lb (28 Kgm) beginning with the center screw and tightening alternate screws toward each end to insure the bedknife will be flat against the bedbar.

4. Install the bedbar/bedknife assembly to the cutting unit.

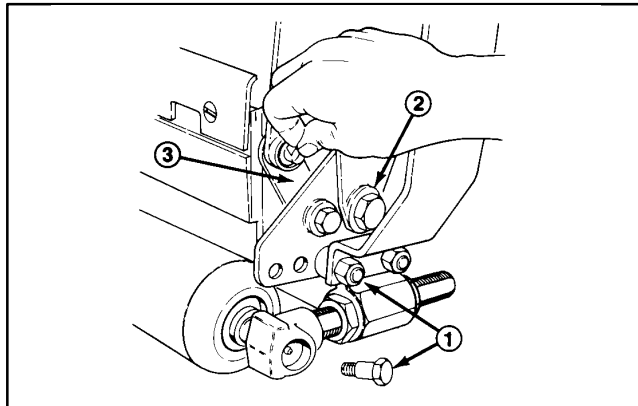

Figure 16

1. Shoulder bolts (2 each side) 2. Bushing 3. Spacer

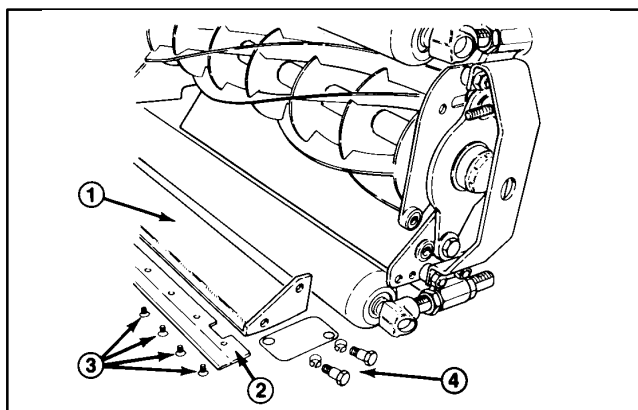

Figure 17

1. Bedbar 2. Bedknife 3. Bedknife mounting screws 4. Bedbar mounting components

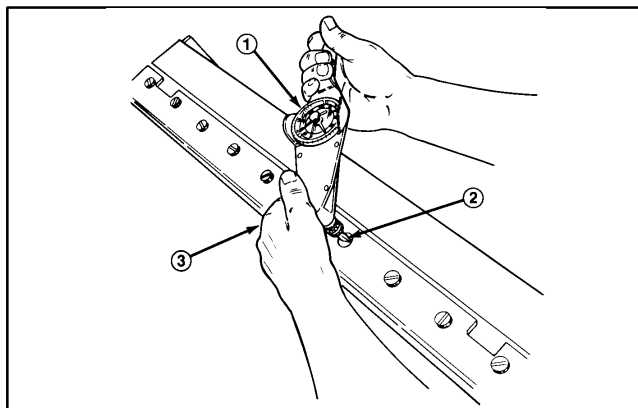

Figure 18

1. Torque wrench
2. Part No. 51-0880 Tool
3. Torque from the center out

Servicing the Reel Assembly

Disassembly:

1. Remove the guards from each end of the cutting unit and the front and rear roller assemblies (Fig. 19).
2. Remove the shoulder bolts, bushings and spacers from each end of the unit and remove the bedbar/bed-knife assembly (Fig. 20).
3. Remove the inboard locknut from the adjuster pin, the fasteners for the bracket and remove the adjusting handle assembly from the side plate (Fig. 20).

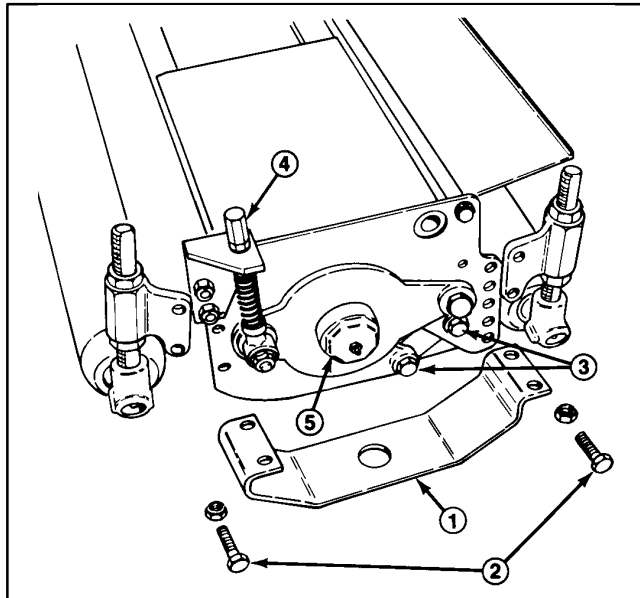

Figure 19

- | | |
|-----------------------------|-----------------------|
| 1. Guard | 4. Adjusting assembly |
| 2. Mounting fasteners | 5. Dust cap |
| 3. Bedbar mounting assembly | |

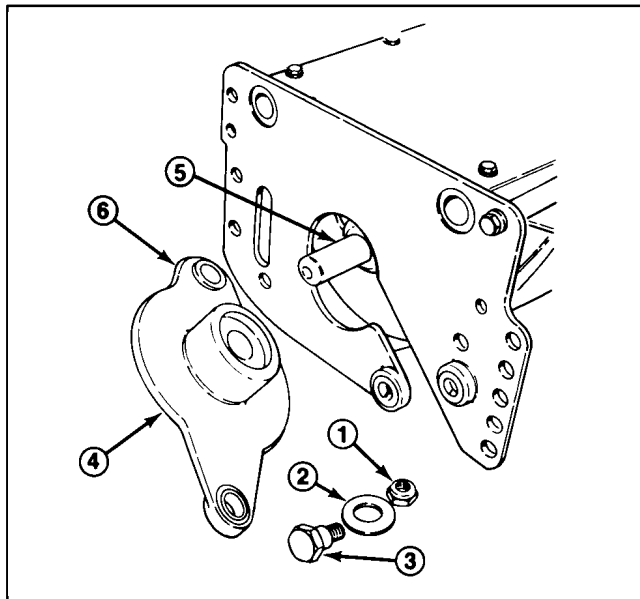

Figure 20

- | | |
|----------------------|--------------------|
| 1. Locknut | 4. Bearing housing |
| 2. Belleville washer | 5. Reel shaft |
| 3. Shoulder bolt | 6. Flange bushing |

4. Disassemble the cone nut from the shoulder bolt securing the bearing housing to the side plate, remove the belleville washer and bolt and slide the bearing housing off the reel shaft (Fig. 21).

5. Disassemble the cover from the drive housing and remove the drive belt from the housing (Fig. 22).

6. Remove the reel capscrew, toothed washer and pulley washer from the reel shaft (Fig. 22). (Note: Capscrew is assembled with a thread locking compound).

7. Using a puller, remove the driven pulley from the reel shaft (Fig. 22). Remove the woodruff key from the reel shaft.

8. Remove the adjustment assembly and cone nut, belleville washer and shoulder bolt securing the housing to the side plate (Fig. 22). Remove the housing.

9. Slide the reel assembly out of the slots in the side plates.

10. To remove the bearing and seals from the drive housing, remove the retaining ring from inside the housing. Pry the outer seal out of the belt drive case side. Press the bearing and rear seal out from the outer side of the housing.

11. To remove the bearing and seal from the bearing housing, remove the dust cap (Fig. 19) and press the bearing and seal out of the housing.

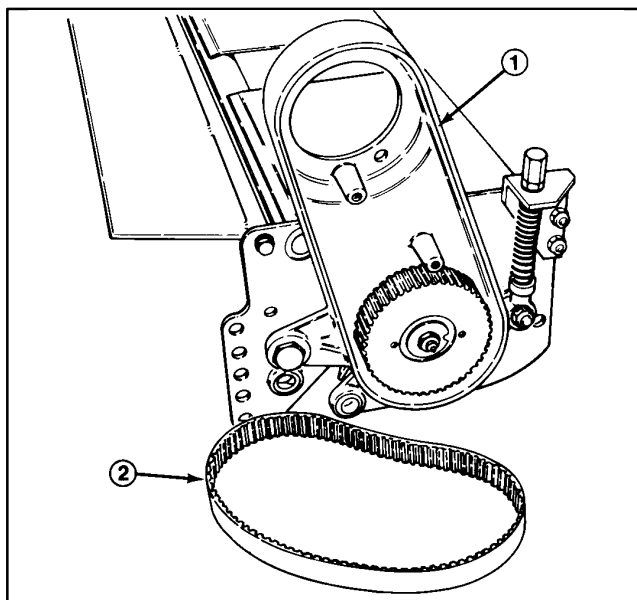

Figure 21

- 1. Drive housing (cover removed)
- 2. Drive belt

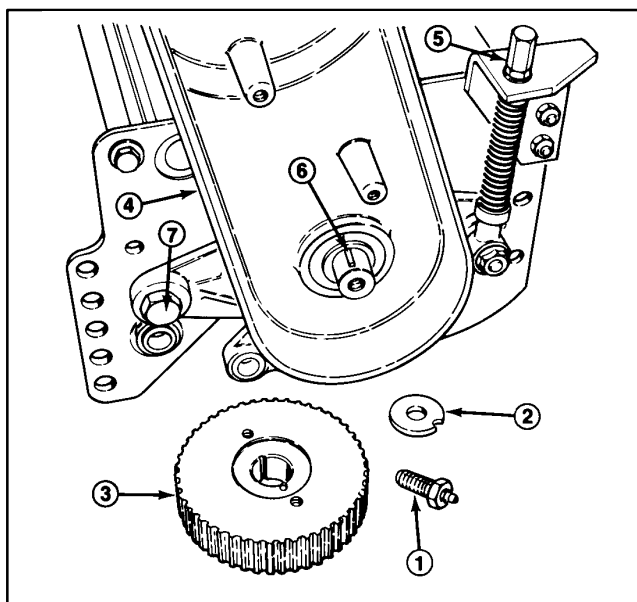

Figure 22

- 1. Reel capscrew
- 2. Pulley washer
- 3. Driven pulley
- 4. Drive housing
- 5. Adjustment handle assembly
- 6. Woodruff key
- 7. Drive housing fasteners

Assembly:

1. Inspect the flange bushings in the mounting holes for the drive housing and bearing housing for wear (Fig. 20). Replace, if necessary.
2. Assemble the outer seal (lip facing in to retain grease) into the drive housing using Loctite 242 retaining compound on the outer diameter. Apply a light coat of oil to the seal lips and insert the bearing assembly through the seal from the opposite side (Fig 23).
3. Apply a light coating of oil to the inner seal lips and install (lip facing away from the bearing and toward the reel) in the housing. Install the retaining ring to secure the assembly in the housing (Fig. 23).
4. Apply a light coat of oil to the seal lips of the seal for the bearing housing and install (lip facing away from the bearing) over the bearing assembly (Fig. 23).
5. Insert the bearing and seal in the housing and install the dust cap into the housing.
6. Assemble the reel assembly to the frame. Ensure the shield washer is installed on the drive housing end of the reel shaft. Align drive pin on reel shaft with slot in bearing and slide the drive housing onto the shaft.
7. Insert the shoulder bolt through the Belleville washer and rear housing mounting hole. Slide the bolt through the side plate mounting hole (Fig. 20). Install the cone nut locknut onto the bolt. Tighten the cone nut to 45 – 55 ft.-lbs.
8. Align the drive pin on the reel shaft with the notch in the bearing inner race and slide the bearing housing over the opposite end of the reel shaft. Insert the shoulder bolt and belleville washer through the rear bearing housing mounting hole. Slide the bolt through the side plate mounting hole. Install the cone onto the bolt. Tighten the cone nut to 45 – 55 ft.-lbs.
9. Install the woodruff key in the drive housing end of the reel shaft and install the driven pulley onto the shaft.
10. Ensure the slot in the pulley washer is aligned with the roll pin in the pulley and install the washer, toothed washer and reel capscrew (Fig. 21). Apply a medium strength thread locking compound to the reel capscrew during assembly. Torque the capscrew to 45 – 55 ft.-lbs.
11. Install the reel adjustment assemblies to each side plate. Install roll pins before tightening fasteners.
12. Install the bedbar/bedknife assembly.
13. Install the front and rear roller assemblies or skids.
14. To adjust the reel to the bedknife; refer to Reel to Bedknife Adjustment. To adjust the height-of-cut; refer to Height-of-Cut Adjustment section.

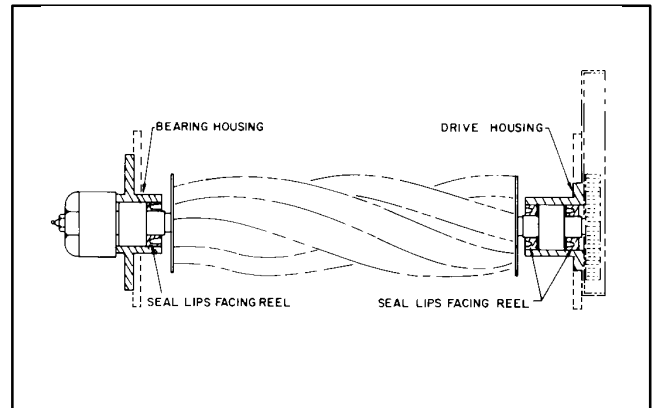

Figure 23

Roller Removal and Installation

1. Remove the fasteners securing the guard and roller adjustment housing to the side plate (Fig. 24) or unscrew the upper cone nut and drop the threaded rod out of the adjustment housing (Fig. 25).

2. The threaded rod and collar assembly can be removed from the roller by sliding it off the shaft at both ends (Fig. 25).

IMPORTANT: When assembling a new roller to the cutting unit mount the roller so that the roller shaft "locknut" is on the right side of the cutting unit (Fig. 25). (As viewed by the operator sitting on seat of machine). This prevents the lock nut from loosening during operation.

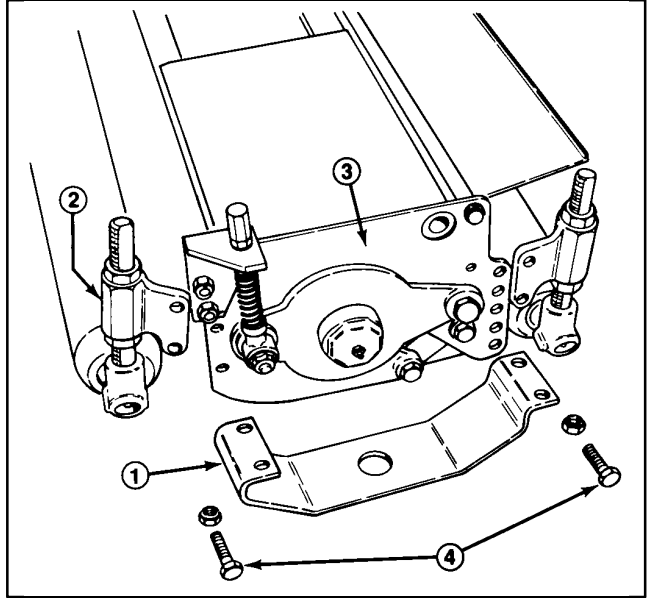

Figure 24

1. Guard
2. Roller adjustment housing
3. Side plate
4. Mounting fasteners

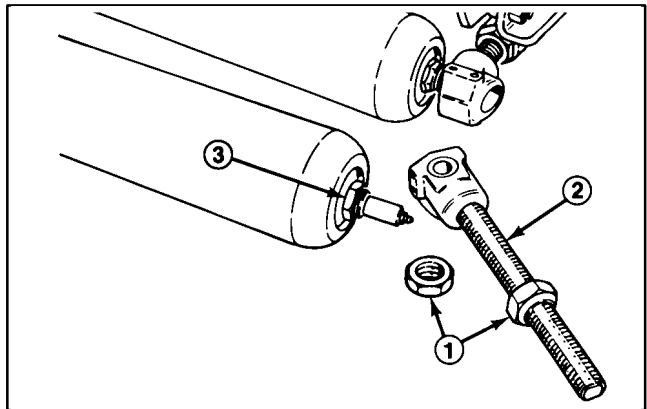

Figure 25

1. Cone nut
2. Rod and collar assembly
3. Flex locknut



Commercial Products