



Count on it.

Service Manual

Reelmaster® 5210/5410/5510/5610

**(Models 03660, 03670, 03680,
03690 and 03691)**

Reader Comments

The Toro Company Technical Assistance Center maintains a continuous effort to improve the quality and usefulness of its publications. To do this effectively, we encourage user feedback. Please comment on the completeness, accuracy, organization, usability, and readability of this manual by an e-mail to servicemanuals@toro.com

or Mail to:

**Technical Publication Manager, Commercial
The Toro Company
8111 Lyndale Avenue South
Bloomington, MN 55420-1196
Phone: +1 952-887-8495**

NOTES



Service Manual

(Models 03660, 03670, 03680, 03690 and 03691)

Reelmaster® 5210/5410/5510/5610

Preface

The purpose of this publication is to provide the service technician with information for troubleshooting, testing, and repair of major systems and components on the Reelmaster 5010 series: the 5210, 5410, 5510 and 5610 (Models 03660, 03670, 03680, 03690 and 03691).

REFER TO THE TRACTION UNIT AND CUTTING UNIT OPERATOR'S MANUALS FOR OPERATING, MAINTENANCE AND ADJUSTMENT INSTRUCTIONS. Space is provided in Chapter 2 of this book to insert the Operator's Manuals and Parts Catalogs for your machine. Additional copies of the Operator's Manual and Parts Catalog are available on the internet at www.Toro.com.

The Toro Company reserves the right to change product specifications or this publication without notice.



This safety symbol means DANGER, WARNING, or CAUTION, PERSONAL SAFETY INSTRUCTION. When you see this symbol, carefully read the instructions that follow. Failure to obey the instructions may result in personal injury.

NOTE: A **NOTE** will give general information about the correct operation, maintenance, service, testing or repair of the machine.

IMPORTANT: The **IMPORTANT** notice will give important instructions which must be followed to prevent damage to systems or components on the machine.



This page is intentionally blank.

Table Of Contents

Chapter 1 – Safety

Safety Instructions	1 – 2
Jacking Instructions	1 – 4
Safety and Instruction Decals	1 – 4

Chapter 2 – Product Records and Maintenance

Product Records	2 – 1
Maintenance	2 – 1
Equivalents and Conversions	2 – 2
Torque Specifications	2 – 3

Chapter 3 – Kubota Diesel Engine

General Information	3 – 1
Specifications	3 – 2
Adjustments	3 – 5
Service and Repairs	3 – 6

KUBOTA WORKSHOP MANUAL: 05 SERIES DIESEL ENGINE

Chapter 4 – Hydraulic System

Specifications	4 – 2
General Information	4 – 3
Hydraulic Schematics	4 – 7
Hydraulic Flow Diagrams	4 – 8
Special Tools	4 – 18
Troubleshooting	4 – 22
Testing	4 – 28
Service and Repairs	4 – 58

DANFOSS LPV CLOSED CIRCUIT AXIAL PISTON PUMPS REPAIR MANUAL

DANFOSS LPV CLOSED CIRCUIT AXIAL PISTON PUMPS SERVICE INSTRUCTIONS

PARKER TORQMOTOR™ SERVICE PROCEDURE (TC, TB, TE, TJ, TF, TG, TH AND TL SERIES)

EATON DELTA MOTORS PARTS AND REPAIR MANUAL

DANFOSS STEERING UNIT TYPE OSPM SERVICE MANUAL

Chapter 5 – Electrical System

General Information	5 – 1
Electrical Diagrams	5 – 1
Special Tools	5 – 2
Troubleshooting	5 – 4
Electrical System Quick Checks	5 – 18
Adjustments	5 – 20
Component Testing	5 – 23
Service and Repairs	5 – 46

Chapter 6 – Chassis

Specifications	6 – 2
General Information	6 – 2
Service and Repairs	6 – 4

Chapter 7 – DPA Cutting Units

Specifications	7 – 2
General Information	7 – 3
Special Tools	7 – 4
Factors That Can Affect Cutting Performance	7 – 9
Set-Up and Adjustments	7 – 12
Service and Repairs	7 – 16

Chapter 8 – Belt Driven Groomer (Optional)

Grooming Performance	8 – 2
Troubleshooting	8 – 3
Adjustments	8 – 4
Service and Repairs	8 – 5

Chapter 9 – Universal Groomer (Optional)

Grooming Performance	9 – 2
Troubleshooting	9 – 3
Service and Repairs	9 – 4

Chapter 10 – Foldout Drawings

Electrical Drawing Designations	10 – 2
Hydraulic Schematics	10 – 3
Electrical Schematics	10 – 5
Electrical Circuit Diagrams	10 – 7
Wire Harness Drawings	10 – 12
Turf Defender™ (Optional) Electrical Schematic	10 – 22

Safety

Product Records and Maintenance

Kubota Diesel Engine

Hydraulic System

Electrical System

Chassis

DPA Cutting Units

Belt Driven Groomer (Opt.)

Universal Groomer (Opt.)

This page is intentionally blank.



Table of Contents

SAFETY INSTRUCTIONS 2
 Before Operating 2
 While Operating 2
 Maintenance and Service 3
JACKING INSTRUCTIONS 4
SAFETY AND INSTRUCTION DECALS 4

Safety Instructions

Reelmaster machines meet or exceed safety standard specifications when weights are installed according to information in the Traction Unit Operator's Manual. Although hazard control and accident prevention are partially dependent upon the design and configuration of the machine, these factors are also dependent upon the awareness, concern and proper training of the personnel involved in the operation, transport, maintenance and storage of the machine. Improper use or maintenance of the machine can result in injury or death. To re-

duce the potential for injury or death, comply with the following safety instructions.



Before Operating

1. Review and understand the contents of the Operator's Manuals and Operator Training DVD before starting and operating the machine. Become familiar with the controls and know how to stop the machine and engine quickly. Additional copies of the Operator's Manual are available on the internet at www.Toro.com.
2. Keep all shields, safety devices and decals in place. If a shield, safety device or decal is defective, illegible or damaged, repair or replace it before operating the machine. Also tighten any loose nuts, bolts or screws to ensure machine is in safe operating condition.
3. Assure interlock switches are adjusted correctly so engine cannot be started unless traction pedal is in NEUTRAL and PTO switch is OFF (disengaged).

4. Since diesel fuel is highly flammable, handle it carefully:
 - A. Store fuel in containers specifically designed for this purpose.
 - B. Do not remove machine fuel tank cap while engine is hot or running.
 - C. Do not smoke while handling fuel.
 - D. Fill fuel tank outdoors and only to within an inch of the top of the tank, not the filler neck. Do not overfill.
 - E. Replace fuel tank and fuel container caps securely after refueling machine.
 - F. If fuel is spilled, do not attempt to start the engine but move the machine away from the area of spillage. Avoid creating any source of ignition until fuel vapors have dissipated. Wipe up any spilled fuel.

While Operating

1. Sit on the seat when starting and operating the machine.
2. Before starting the engine:
 - A. Apply the parking brake.
 - B. Make sure the traction pedal is in NEUTRAL and the PTO switch is OFF (disengaged).
 - C. After engine is started, release parking brake and keep foot off traction pedal. Machine must not move. If movement is evident, the traction pedal linkage is adjusted incorrectly; therefore, shut engine off and adjust traction pedal linkage until machine does not move when traction pedal is released (see Traction Unit Operator's Manual).

3. Do not run engine in a confined area without adequate ventilation. Exhaust fumes are hazardous and could possibly be deadly.
4. Do not touch engine, radiator or exhaust system while engine is running or soon after it is stopped. These areas could be hot enough to cause burns.
5. Before getting off the seat:
 - A. Ensure that traction pedal is in NEUTRAL.
 - B. Lower and disengage cutting units and wait for all movement to stop.
 - C. Set parking brake.
 - D. Stop engine and remove key from ignition switch.

6. Anytime the machine is parked (short or long term), the cutting units should be lowered to the ground. This relieves pressure from the hydraulic lift circuit and eliminates the risk of the cutting units unexpectedly lowering to the ground.
7. Do not park on slopes unless wheels are chocked or blocked.

Maintenance and Service

1. Before servicing or making adjustments, lower cutting units, stop engine, apply parking brake and remove key from the ignition switch.
2. Make sure machine is in safe operating condition by keeping all nuts, bolts and screws tight.
3. Never store the machine or fuel container inside where there is an open flame, such as near a water heater or furnace.
4. Make sure all hydraulic line connectors are tight, and all hydraulic hoses and lines are in good condition before applying pressure to the hydraulic system.
5. Keep body and hands away from pin hole leaks in hydraulic lines that eject high pressure hydraulic fluid. Use cardboard or paper to find hydraulic leaks. Hydraulic fluid escaping under pressure can penetrate skin and cause injury. Fluid accidentally injected into the skin must be surgically removed within a few hours by a doctor familiar with this form of injury or gangrene may result.
6. Before disconnecting or performing any work on the hydraulic system, all pressure in the system must be relieved by using all of the hydraulic controls (see Relieving Hydraulic Pressure in the General Information section of Chapter 4 - Hydraulic System).
7. Use care when checking or servicing the cutting units. Wear gloves and use caution when servicing them.
8. To reduce potential fire hazard, keep engine area free of excessive grease, grass, leaves and dirt. Clean protective screen on machine frequently.
9. If engine must be running to perform maintenance or to make an adjustment, keep hands, feet, clothing and other parts of the body away from the cutting units and other moving parts. Keep bystanders away.
10. Do not overspeed the engine by changing governor setting. To assure safety and accuracy, check maximum engine speed with a tachometer.
11. Shut engine off before checking or adding oil to the crankcase.
12. Disconnect battery before servicing the machine. Disconnect negative battery cable first and positive cable last. If battery voltage is required for troubleshooting or test procedures, temporarily connect the battery. Reconnect positive battery cable first and negative cable last.
13. Battery acid is poisonous and can cause burns. Avoid contact with skin, eyes and clothing. Protect your face, eyes and clothing when working with a battery.
14. Battery gases can explode. Keep cigarettes, sparks and flames away from the battery.
15. When changing attachments, tires or performing other service, use correct blocks, hoists and jacks. Make sure machine is parked on a solid level floor such as a concrete floor. Prior to raising the machine, remove any attachments that may interfere with the safe and proper raising of the machine. Always chock or block wheels. Use jack stands or appropriate load holding devices to support the raised machine. If the machine is not properly supported, the machine may move or fall, which may result in personal injury (see Jacking Instructions in this section).
16. If major repairs are ever needed or assistance is desired, contact an Authorized Toro Distributor.
17. If welding on the machine is necessary, disconnect the negative battery cable to prevent electrical system damage.
18. At the time of manufacture, the machine conformed to the safety standards for riding mowers. To assure optimum performance and continued safety certification of the machine, use genuine Toro replacement parts and accessories. Replacement parts and accessories made by other manufacturers may result in non-conformance with the safety standards, and the warranty may be voided.

Jacking Instructions



CAUTION

When changing attachments, tires or performing other service, use correct blocks, hoists and jacks. Make sure machine is parked on a solid, level surface such as a concrete floor. Prior to raising machine, remove any attachments that may interfere with the safe and proper raising of the machine. Always chock or block wheels. Use jack stands or other appropriate load holding devices to support the raised machine. If the machine is not properly supported, the machine may move or fall, which may result in personal injury.



Figure 1

1. Front wheel
2. Front jacking point

Front End Jacking (Fig. 1)

1. Apply parking brake and chock both rear tires to prevent the machine from moving.
2. Position jack securely under the frame axle tube, just to the inside of the front wheel.
3. Jack front of machine off the ground.
4. Position jack stands under the frame as close to the wheel as possible to support the machine.

Rear End Jacking (Fig. 2)

1. Apply parking brake and chock both front tires to prevent the machine from moving.
2. Place jack securely at the center of the rear axle under the axle pivot bracket. Jack rear of machine off the ground.
3. Position jack stands under the frame to support the machine.

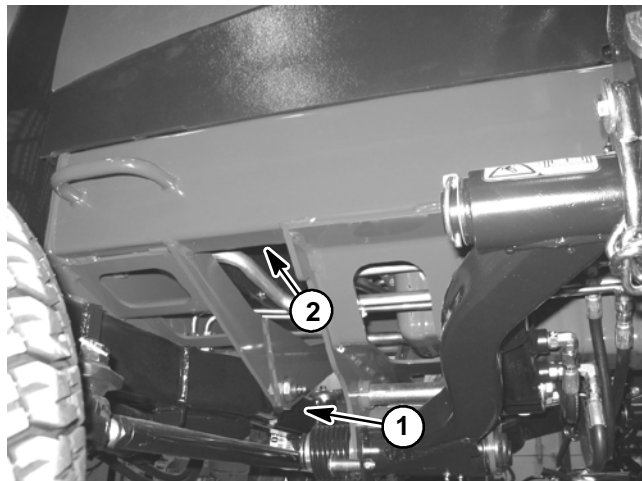

Figure 2

1. Axle center
2. Jack stand location

Safety and Instruction Decals

Numerous safety and instruction decals are affixed to the traction unit and the cutting units of your Reelmaster. If any decal becomes illegible or damaged, install a new decal. Part numbers for decals are listed in your Part Catalogs. Order replacement decals from your Authorized Toro Distributor.



Product Records and Maintenance

Table of Contents

PRODUCT RECORDS 1
MAINTENANCE 1
EQUIVALENTS AND CONVERSIONS 2
 Decimal and Millimeter Equivalents 2
 U.S. to Metric Conversions 2
TORQUE SPECIFICATIONS 3
 Fastener Identification 3
 Using a Torque Wrench with an Offset Wrench .. 3
 Standard Torque for Dry, Zinc Plated and
 Steel Fasteners (Inch Series) 4
 Standard Torque for Dry, Zinc Plated and
 Steel Fasteners (Metric Series) 5
 Other Torque Specifications 6
 Conversion Factors 6

Product Records

Insert Operator’s Manuals and Parts Catalogs for your Reelmaster at the end of this chapter. Additionally, if any optional equipment or accessories have been installed to your machine, insert the Installation Instructions, Operator’s Manuals and Parts Catalogs for those options at the end of this chapter.

Maintenance

Maintenance procedures and recommended service intervals for your Reelmaster are covered in the Traction Unit and Cutting Unit Operator’s Manuals. Refer to those publications when performing regular equipment maintenance.

Equivalents and Conversions

Decimal and Millimeter Equivalents

Fractions	Decimals	mm	Fractions	Decimals	mm		
	1/64	0.015625	— 0.397	33/64	0.515625	— 13.097	
	1/32	0.03125	— 0.794	17/32	0.53125	— 13.494	
	3/64	0.046875	— 1.191	35/64	0.546875	— 13.891	
1/16	—	0.0625	— 1.588	9/16	—	0.5625	— 14.288
	5/64	0.078125	— 1.984	37/64	0.578125	— 14.684	
	3/32	0.09375	— 2.381	19/32	—	0.59375	— 15.081
	7/64	0.109275	— 2.778	39/64	0.609375	— 15.478	
1/8	—	0.1250	— 3.175	5/8	—	0.6250	— 15.875
	9/64	0.140625	— 3.572	41/64	0.640625	— 16.272	
	5/32	0.15625	— 3.969	21/32	—	0.65625	— 16.669
	11/64	0.171875	— 4.366	43/64	0.671875	— 17.066	
3/16	—	0.1875	— 4.762	11/16	—	0.6875	— 17.462
	13/64	0.203125	— 5.159	45/64	0.703125	— 17.859	
	7/32	0.21875	— 5.556	23/32	—	0.71875	— 18.256
	15/64	0.234375	— 5.953	47/64	0.734375	— 18.653	
1/4	—	0.2500	— 6.350	3/4	—	0.7500	— 19.050
	17/64	0.265625	— 6.747	49/64	0.765625	— 19.447	
	9/32	0.28125	— 7.144	25/32	—	0.78125	— 19.844
	19/64	0.296875	— 7.541	51/64	0.796875	— 20.241	
5/16	—	0.3125	— 7.938	13/16	—	0.8125	— 20.638
	21/64	0.328125	— 8.334	53/64	0.828125	— 21.034	
	11/32	0.34375	— 8.731	27/32	—	0.84375	— 21.431
	23/64	0.359375	— 9.128	55/64	0.859375	— 21.828	
3/8	—	0.3750	— 9.525	7/8	—	0.8750	— 22.225
	25/64	0.390625	— 9.922	57/64	0.890625	— 22.622	
	13/32	0.40625	— 10.319	29/32	—	0.90625	— 23.019
	27/64	0.421875	— 10.716	59/64	0.921875	— 23.416	
7/16	—	0.4375	— 11.112	15/16	—	0.9375	— 23.812
	29/64	0.453125	— 11.509	61/64	0.953125	— 24.209	
	15/32	0.46875	— 11.906	31/32	—	0.96875	— 24.606
	31/64	0.484375	— 12.303	63/64	0.984375	— 25.003	
1/2	—	0.5000	— 12.700	1	—	1.000	— 25.400
	1 mm = 0.03937 in.			0.001 in. = 0.0254 mm			

U.S. to Metric Conversions

	To Convert	Into	Multiply By
Linear Measurement	Miles	Kilometers	1.609
	Yards	Meters	0.9144
	Feet	Meters	0.3048
	Feet	Centimeters	30.48
	Inches	Meters	0.0254
	Inches	Centimeters	2.54
	Inches	Millimeters	25.4
Area	Square Miles	Square Kilometers	2.59
	Square Feet	Square Meters	0.0929
	Square Inches	Square Centimeters	6.452
	Acre	Hectare	0.4047
Volume	Cubic Yards	Cubic Meters	0.7646
	Cubic Feet	Cubic Meters	0.02832
	Cubic Inches	Cubic Centimeters	16.39
Weight	Tons (Short)	Metric Tons	0.9078
	Pounds	Kilograms	0.4536
	Ounces (Avdp.)	Grams	28.3495
Pressure	Pounds/Sq. In.	Kilopascal	6.895
	Pounds/Sq. In.	Bar	0.069
Work	Foot-pounds	Newton-Meters	1.356
	Foot-pounds	Kilogram-Meters	0.1383
	Inch-pounds	Kilogram-Centimeters	1.152144
Liquid Volume	Quarts	Liters	0.9463
	Gallons	Liters	3.785
Liquid Flow	Gallons/Minute	Liters/Minute	3.785
Temperature	Fahrenheit	Celsius	1. Subtract 32°
			2. Multiply by 5/9

Torque Specifications

Recommended fastener torque values are listed in the following tables. For critical applications, as determined by Toro, either the recommended torque or a torque that is unique to the application is clearly identified and specified in this Service Manual.

These Torque Specifications for the installation and tightening of fasteners shall apply to all fasteners which do not have a specific requirement identified in this Service Manual. The following factors shall be considered when applying torque: cleanliness of the fastener, use of a thread sealant (e.g. Loctite), degree of lubrication on the fastener, presence of a prevailing torque feature (e.g. Nylock nut), hardness of the surface underneath the fastener's head or similar condition which affects the installation.

As noted in the following tables, torque values should be **reduced by 25% for lubricated fasteners** to achieve the similar stress as a dry fastener. Torque values may also have to be reduced when the fastener is threaded into aluminum or brass. The specific torque value should be determined based on the aluminum or brass material strength, fastener size, length of thread engagement, etc.

The standard method of verifying torque shall be performed by marking a line on the fastener (head or nut) and mating part, then back off fastener 1/4 of a turn. Measure the torque required to tighten the fastener until the lines match up.

Fastener Identification

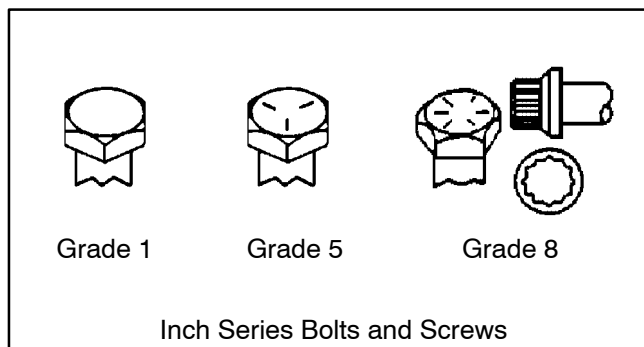

Figure 1

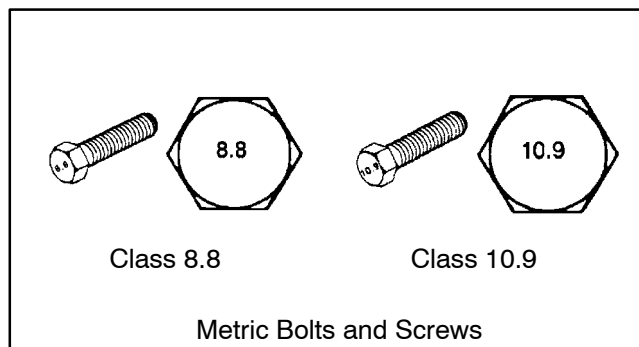

Figure 2

Using a Torque Wrench with an Offset Wrench

Use of an offset wrench (e.g. crowfoot wrench) will affect torque wrench calibration due to the effective change of torque wrench length. When using a torque wrench with an offset wrench, multiply the listed torque recommendation by the calculated torque conversion factor (Fig. 3) to determine proper tightening torque. Tightening torque when using a torque wrench with an offset wrench will be lower than the listed torque recommendation.

Example: The measured effective length of the torque wrench (distance from the center of the handle to the center of the square drive) is 18".

The measured effective length of the torque wrench with the offset wrench installed (distance from the center of the handle to the center of the offset wrench) is 19".

The calculated torque conversion factor for this torque wrench with this offset wrench would be $18 / 19 = 0.947$.

If the listed torque recommendation for a fastener is from 76 to 94 ft-lb, the proper torque when using this torque wrench with an offset wrench would be from 72 to 89 ft-lb.

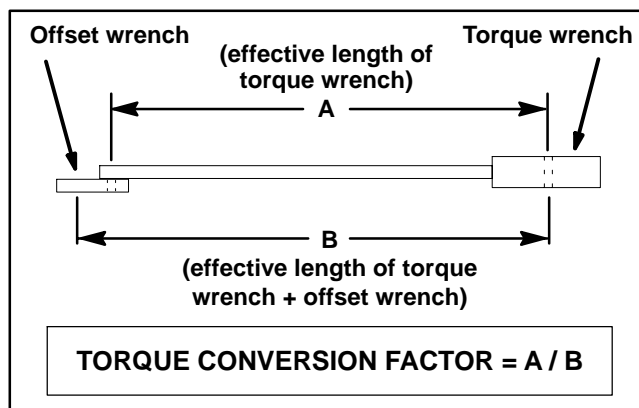

Figure 3

Standard Torque for Dry, Zinc Plated and Steel Fasteners (Inch Series)

Thread Size	Grade 1, 5 & 8 with Thin Height Nuts	SAE Grade 1 Bolts, Screws, Studs & Sems with Regular Height Nuts (SAE J995 Grade 2 or Stronger Nuts)		SAE Grade 5 Bolts, Screws, Studs & Sems with Regular Height Nuts (SAE J995 Grade 2 or Stronger Nuts)		SAE Grade 8 Bolts, Screws, Studs & Sems with Regular Height Nuts (SAE J995 Grade 5 or Stronger Nuts)	
	in-lb	in-lb	N-cm	in-lb	N-cm	in-lb	N-cm
# 6 - 32 UNC	10 ± 2	13 ± 2	147 ± 23	15 ± 2	169 ± 23	23 ± 3	262 ± 34
# 6 - 40 UNF				17 ± 2	192 ± 23	25 ± 3	282 ± 34
# 8 - 32 UNC	13 ± 2	25 ± 5	282 ± 30	29 ± 3	328 ± 34	41 ± 5	463 ± 56
# 8 - 36 UNF				31 ± 4	350 ± 45	43 ± 5	486 ± 56
# 10 - 24 UNC	18 ± 2	30 ± 5	339 ± 56	42 ± 5	475 ± 56	60 ± 6	678 ± 68
# 10 - 32 UNF				48 ± 5	542 ± 56	68 ± 7	768 ± 79
1/4 - 20 UNC	48 ± 7	53 ± 7	599 ± 79	100 ± 10	1130 ± 113	140 ± 15	1582 ± 169
1/4 - 28 UNF	53 ± 7	65 ± 10	734 ± 113	115 ± 12	1299 ± 136	160 ± 17	1808 ± 192
5/16 - 18 UNC	115 ± 15	105 ± 15	1186 ± 169	200 ± 25	2260 ± 282	300 ± 30	3390 ± 339
5/16 - 24 UNF	138 ± 17	128 ± 17	1446 ± 192	225 ± 25	2542 ± 282	325 ± 33	3672 ± 373
	ft-lb	ft-lb	N-m	ft-lb	N-m	ft-lb	N-m
3/8 - 16 UNC	16 ± 2	16 ± 2	22 ± 3	30 ± 3	41 ± 4	43 ± 5	58 ± 7
3/8 - 24 UNF	17 ± 2	18 ± 2	24 ± 3	35 ± 4	47 ± 5	50 ± 6	68 ± 8
7/16 - 14 UNC	27 ± 3	27 ± 3	37 ± 4	50 ± 5	68 ± 7	70 ± 7	95 ± 9
7/16 - 20 UNF	29 ± 3	29 ± 3	39 ± 4	55 ± 6	75 ± 8	77 ± 8	104 ± 11
1/2 - 13 UNC	30 ± 3	48 ± 7	65 ± 9	75 ± 8	102 ± 11	105 ± 11	142 ± 15
1/2 - 20 UNF	32 ± 4	53 ± 7	72 ± 9	85 ± 9	115 ± 12	120 ± 12	163 ± 16
5/8 - 11 UNC	65 ± 10	88 ± 12	119 ± 16	150 ± 15	203 ± 20	210 ± 21	285 ± 28
5/8 - 18 UNF	75 ± 10	95 ± 15	129 ± 20	170 ± 18	230 ± 24	240 ± 24	325 ± 33
3/4 - 10 UNC	93 ± 12	140 ± 20	190 ± 27	265 ± 27	359 ± 37	375 ± 38	508 ± 52
3/4 - 16 UNF	115 ± 15	165 ± 25	224 ± 34	300 ± 30	407 ± 41	420 ± 43	569 ± 58
7/8 - 9 UNC	140 ± 20	225 ± 25	305 ± 34	430 ± 45	583 ± 61	600 ± 60	813 ± 81
7/8 - 14 UNF	155 ± 25	260 ± 30	353 ± 41	475 ± 48	644 ± 65	667 ± 66	904 ± 89

NOTE: Reduce torque values listed in the table above by 25% for lubricated fasteners. Lubricated fasteners are defined as threads coated with a lubricant such as engine oil or thread sealant such as Loctite.

NOTE: Torque values may have to be reduced when installing fasteners into threaded aluminum or brass. The specific torque value should be determined based on the fastener size, the aluminum or base material strength, length of thread engagement, etc.

NOTE: The nominal torque values listed above for Grade 5 and 8 fasteners are based on 75% of the minimum proof load specified in SAE J429. The tolerance is approximately ± 10% of the nominal torque value. Thin height nuts include jam nuts.

Standard Torque for Dry, Zinc Plated and Steel Fasteners (Metric Series)

Thread Size	Class 8.8 Bolts, Screws and Studs with Regular Height Nuts (Class 8 or Stronger Nuts)		Class 10.9 Bolts, Screws and Studs with Regular Height Nuts (Class 10 or Stronger Nuts)	
M5 X 0.8	57 ± 6 in-lb	644 ± 68 N-cm	78 ± 8 in-lb	881 ± 90 N-cm
M6 X 1.0	96 ± 10 in-lb	1085 ± 113 N-cm	133 ± 14 in-lb	1503 ± 158 N-cm
M8 X 1.25	19 ± 2 ft-lb	26 ± 3 N-m	28 ± 3 ft-lb	38 ± 4 N-m
M10 X 1.5	38 ± 4 ft-lb	52 ± 5 N-m	54 ± 6 ft-lb	73 ± 8 N-m
M12 X 1.75	66 ± 7 ft-lb	90 ± 10 N-m	93 ± 10 ft-lb	126 ± 14 N-m
M16 X 2.0	166 ± 17 ft-lb	225 ± 23 N-m	229 ± 23 ft-lb	310 ± 31 N-m
M20 X 2.5	325 ± 33 ft-lb	440 ± 45 N-m	450 ± 46 ft-lb	610 ± 62 N-m

NOTE: Reduce torque values listed in the table above by 25% for lubricated fasteners. Lubricated fasteners are defined as threads coated with a lubricant such as engine oil or thread sealant such as Loctite.

NOTE: Torque values may have to be reduced when installing fasteners into threaded aluminum or brass. The specific torque value should be determined based on the fastener size, the aluminum or base material strength, length of thread engagement, etc.

NOTE: The nominal torque values listed above are based on 75% of the minimum proof load specified in SAE J1199. The tolerance is approximately ± 10% of the nominal torque value.

Other Torque Specifications

SAE Grade 8 Steel Set Screws

Thread Size	Recommended Torque	
	Square Head	Hex Socket
1/4 - 20 UNC	140 ± 20 in-lb	73 ± 12 in-lb
5/16 - 18 UNC	215 ± 35 in-lb	145 ± 20 in-lb
3/8 - 16 UNC	35 ± 10 ft-lb	18 ± 3 ft-lb
1/2 - 13 UNC	75 ± 15 ft-lb	50 ± 10 ft-lb

Wheel Bolts and Lug Nuts

Thread Size	Recommended Torque**	
7/16 - 20 UNF Grade 5	65 ± 10 ft-lb	88 ± 14 N-m
1/2 - 20 UNF Grade 5	80 ± 10 ft-lb	108 ± 14 N-m
M12 X 1.25 Class 8.8	80 ± 10 ft-lb	108 ± 14 N-m
M12 X 1.5 Class 8.8	80 ± 10 ft-lb	108 ± 14 N-m

** For steel wheels and non-lubricated fasteners.

Thread Cutting Screws (Zinc Plated Steel)

Type 1, Type 23 or Type F	
Thread Size	Baseline Torque*
No. 6 - 32 UNC	20 ± 5 in-lb
No. 8 - 32 UNC	30 ± 5 in-lb
No. 10 - 24 UNC	38 ± 7 in-lb
1/4 - 20 UNC	85 ± 15 in-lb
5/16 - 18 UNC	110 ± 20 in-lb
3/8 - 16 UNC	200 ± 100 in-lb

Thread Cutting Screws (Zinc Plated Steel)

Thread Size	Threads per Inch		Baseline Torque*
	Type A	Type B	
No. 6	18	20	20 ± 5 in-lb
No. 8	15	18	30 ± 5 in-lb
No. 10	12	16	38 ± 7 in-lb
No. 12	11	14	85 ± 15 in-lb

* Hole size, material strength, material thickness and finish must be considered when determining specific torque values. All torque values are based on non-lubricated fasteners.

Conversion Factors

$$\text{in-lb} \times 11.2985 = \text{N-cm}$$

$$\text{ft-lb} \times 1.3558 = \text{N-m}$$

$$\text{N-cm} \times 0.08851 = \text{in-lb}$$

$$\text{N-m} \times 0.7376 = \text{ft-lb}$$



Kubota Diesel Engine

Table of Contents

GENERAL INFORMATION	1	SERVICE AND REPAIRS	6
Traction Unit Operator's Manual	1	Fuel System	6
Stopping the Engine (Reelmaster 5610)	1	Air Cleaner	8
SPECIFICATIONS	2	Exhaust System	10
Reelmaster 5210	2	Radiator	12
Reelmaster 5410 and 5510	3	Engine	14
Reelmaster 5610	4	KUBOTA WORKSHOP MANUAL: 05 SERIES DIESEL ENGINE	
ADJUSTMENTS	5		
Adjust Throttle Control	5		

General Information

This Chapter gives information about specifications, troubleshooting, testing and repair of the Kubota diesel engine used in the Reelmaster 5010 Series of machines.

Most repairs and adjustments require tools which are commonly available in many service shops. The use of some specialized test equipment is explained in the engine service manual included at the end of this chapter. However, the cost of the test equipment and the specialized nature of some repairs may dictate that the work be done at an engine repair facility.

Service and repair parts for Kubota diesel engines are supplied through your local Toro Distributor. If a parts list is not available, be sure to provide your distributor with the Toro model and serial number.

Traction Unit Operator's Manual

The Traction Unit Operator's Manual provides information regarding the operation, general maintenance and maintenance intervals for the Kubota diesel engine that powers your Reelmaster machine. Refer to that publication for additional information when servicing the machine.

Stopping the Engine (Reelmaster 5610)

IMPORTANT: The engine used on the Reelmaster 5610 is turbo-charged. Before stopping the engine after mowing or full load operation on Reelmaster 5610 machines, cool the turbo-charger by allowing the engine to idle at low speed for 5 minutes. Failure to do so may lead to turbo-charger trouble.

Specifications: Reelmaster 5210

Item	Description
Make / Designation	Kubota D1105, 4-stroke, Liquid Cooled, OHV Diesel
Number of Cylinders	3
Bore x Stroke	3.07" x 3.09" (78 mm x 78.4 mm)
Total Displacement	68.53 in ³ (1123 cc)
Compression Ratio	22.0:1
Firing Order	1 (fan end) - 2 - 3 (flywheel end)
Dry Weight (approximate)	205 lb. (93 kg)
Fuel	No. 2-D Diesel Fuel (ASTM D975)
Fuel Injection Pump	Bosch MD Type Mini
Fuel Injector Nozzle	Mini Nozzle (DNOPD)
Fuel Tank Capacity	14 U.S. Gallons (53 Liters)
Governor	Centrifugal Mechanical
Low Idle Speed (no load)	1200 to 1300 RPM
High Idle Speed (no load)	3050 to 3250 RPM
Engine Oil	API Classification CH-4, CI-4 or Higher (see Traction Unit Operator's Manual for viscosity recommendations)
Oil Pump	Gear Driven Trochoid Type
Crankcase Oil Capacity	4.0 U.S. Quarts (3.8 Liters) with Filter
Cooling System Capacity (including reserve tank)	5.5 U.S. Quarts (5.2 Liters)
Starter	12 VDC 1.4 KW
Alternator/Regulator	12 VDC 40 Amp

Specifications: Reelmaster 5410 and 5510

Item	Description
Make / Designation	Kubota V1505, 4-stroke, Liquid Cooled, OHV Diesel
Number of Cylinders	4
Bore x Stroke	3.07" x 3.09" (78 mm x 78.4 mm)
Total Displacement	91.4 in ³ (1498 cc)
Compression Ratio	21.0:1
Firing Order	1 (fan end) - 3 - 4 (flywheel end) - 2
Dry Weight (approximate)	242 lbs (110 kg)
Fuel	No. 2-D Diesel Fuel (ASTM D975)
Fuel Injection Pump	Bosch MD Type Mini
Fuel Injector Nozzle	Mini Nozzle (DNOPD)
Fuel Tank Capacity	14 U.S. Gallons (53 Liters)
Governor	Centrifugal Mechanical
Low Idle Speed (no load)	1200 to 1300 RPM
High Idle Speed (no load)	3050 to 3250 RPM
Engine Oil	API Classification CH-4, CI-4 or Higher (see Traction Unit Operator's Manual for viscosity recommendations)
Oil Pump	Gear Driven Trochoid Type
Crankcase Oil Capacity	6.3 U.S. Quarts (6 Liters) with Filter
Cooling System Capacity (including reserve tank)	7 U.S. Quarts (6.6 Liters)
Starter	12 VDC 1.4 KW
Alternator/Regulator	12 VDC 40 Amp

Kubota Diesel
Engine

Specifications: Reelmaster 5610

Item	Description
Make / Designation	Kubota V1505, 4-stroke, Liquid Cooled, OHV, Turbocharged Diesel
Number of Cylinders	4
Bore x Stroke	3.07" x 3.09" (78 mm x 78.4 mm)
Total Displacement	91.4 in ³ (1498 cc)
Compression Ratio	21.0:1
Firing Order	1 (fan end) - 3 - 4 (flywheel end) - 2
Dry Weight (approximate)	251 lbs (114 kg)
Fuel	No. 2-D Diesel Fuel (ASTM D975)
Fuel Injection Pump	Bosch MD Type Mini
Fuel Injector Nozzle	Mini Nozzle (DNOPD)
Fuel Tank Capacity	14 U.S. Gallons (53 Liters)
Governor	Centrifugal Mechanical
Low Idle Speed (no load)	1200 to 1300 RPM
High Idle Speed (no load)	3050 to 3250 RPM
Engine Oil	API Classification CH-4, CI-4 or Higher (see Traction Unit Operator's Manual for viscosity recommendations)
Oil Pump	Gear Driven Trochoid Type
Crankcase Oil Capacity	5 U.S. Quarts (4.7 Liters) with Filter
Cooling System Capacity (including reserve tank)	10 U.S. Quarts (9.5 Liters)
Starter	12 VDC 1.4 KW
Alternator/Regulator	12 VDC 40 Amp

Adjustments

Adjust Throttle Control

Proper throttle operation is dependent upon proper adjustment of throttle control. Make sure throttle control is operating properly.

NOTE: The throttle cable swivel should be positioned in the lowest hole in the speed control lever.

1. Move throttle control lever on control console to **FAST** position.

2. Check position of the engine speed control lever on fuel injection pump. The speed control lever should be contacting the high speed screw when the throttle control lever is in the **FAST** position.

3. If necessary, throttle control can be adjusted by loosening cable clamp screw and repositioning control cable until speed control lever contacts high speed screw when the throttle control lever is in the **FAST** position. Tighten cable clamp screw after adjustment has been completed.

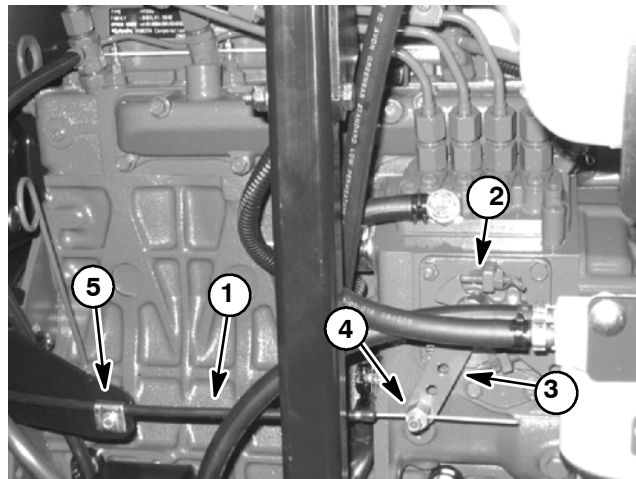

Figure 1

- | | |
|------------------------|----------------|
| 1. Throttle cable | 4. Swivel |
| 2. High speed screw | 5. Cable clamp |
| 3. Speed control lever | |

Service and Repairs

Fuel System

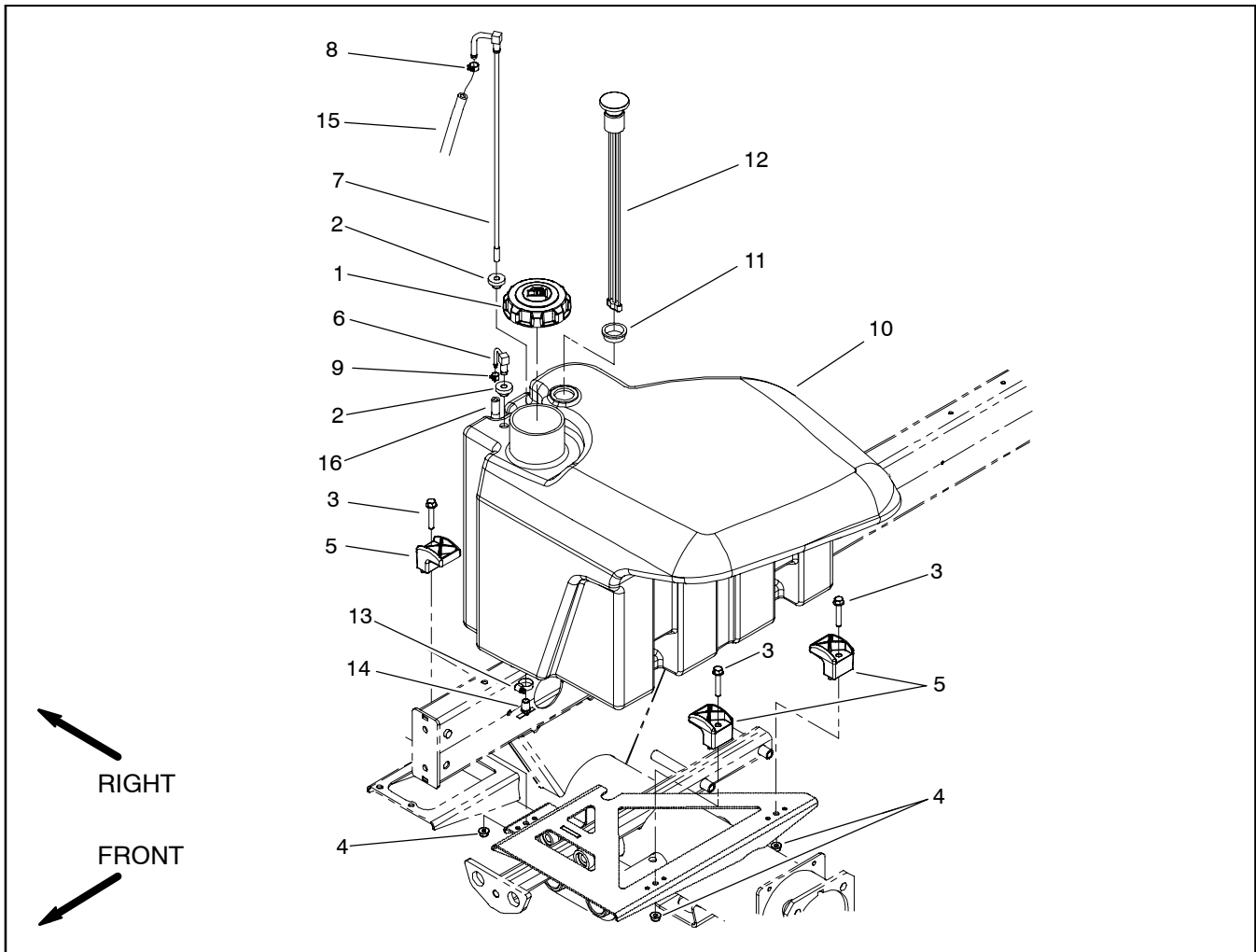

Figure 2

- | | | |
|-------------------------------|--------------------|----------------------|
| 1. Fuel cap | 7. Suction fitting | 12. Fuel gauge |
| 2. Bushing | 8. Hose clamp | 13. Hose clamp |
| 3. Washer head screw (3 used) | 9. Hose clamp | 14. Draincock |
| 4. Flange nut (3 used) | 10. Fuel tank | 15. Fuel hose |
| 5. Clamp (3 used) | 11. Grommet | 16. Return fuel hose |
| 6. Return fitting | | |



DANGER

Because diesel fuel is highly flammable, use caution when storing or handling it. Do not smoke while filling the fuel tank. Do not fill fuel tank while engine is running, when engine is hot or when machine is in an enclosed area. Always fill fuel tank outside and wipe up any spilled diesel fuel before starting the engine. Store fuel in a clean, safety-approved container and keep container cap in place. Use diesel fuel for the engine only; not for any other purpose.

Check Fuel Lines and Connections

Check fuel lines and connections periodically as recommended in the Traction Unit Operator's Manual. Check lines for deterioration, damage, leakage or loose connections. Replace fuel hoses, clamps and connections as necessary.

Drain and Clean Fuel Tank

Drain and clean the fuel tank periodically as recommended in the Traction Unit Operator's Manual. Also, drain and clean the fuel tank if the fuel system becomes contaminated or if the machine is to be stored for an extended period.

To clean fuel tank, flush tank out with clean diesel fuel. Make sure tank is free of all contaminants and debris.

Fuel Tank Removal (Fig. 2)

1. Park machine on a level surface, lower cutting units, stop engine, engage parking brake and remove key from the ignition switch.
2. Place drain pan under fuel tank. Make sure that drain pan is large enough to hold fuel tank contents (see Specifications in this chapter).
3. Open draincock on bottom of fuel tank and allow tank to fully drain. Close draincock.

NOTE: Before removing fuel hoses from tank fittings, label hoses for assembly purposes.

4. Loosen hose clamps and disconnect fuel hoses from suction (item 7) and return (item 6) fittings on the top of the fuel tank.
5. Remove fuel tank using Figure 2 as a guide.

Fuel Tank Installation (Fig. 2)

1. Install fuel tank to frame using Figure 2 as a guide.
2. Correctly connect fuel hoses to suction (item 7) and return (item 6) fittings on the top of the fuel tank. Secure fuel hoses with hose clamps.
3. Make sure that fuel tank draincock is closed. Fill fuel tank.

Air Cleaner

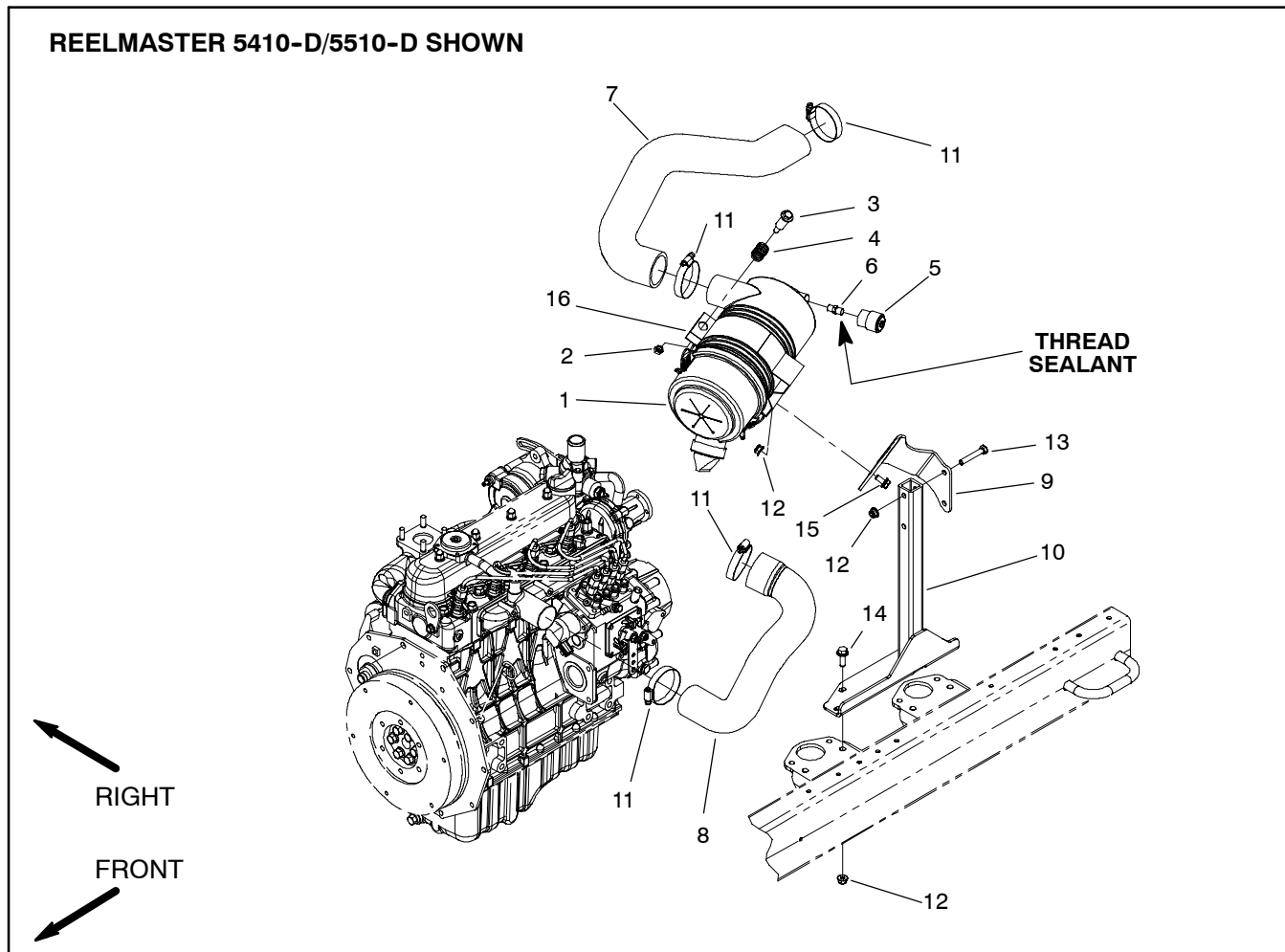

Figure 3

- | | | |
|-------------------------|-----------------------|--------------------------------|
| 1. Air cleaner assembly | 7. Hose | 12. Flange nut |
| 2. Hex nut | 8. Hose | 13. Cap screw (2 used) |
| 3. Bolt | 9. Mount bracket | 14. Flange head screw (4 used) |
| 4. Spring | 10. Air cleaner stand | 15. Flange head screw (2 used) |
| 5. Indicator | 11. Hose clamp | 16. Air cleaner mounting band |
| 6. Adapter | | |

NOTE: The models in the Reelmaster 5010 Series have a very similar air cleaner system. The air cleaner removal and installation procedure is the same for all models.

Removal (Fig. 3)

1. Park machine on a level surface, lower cutting units, stop engine, engage parking brake and remove key from the ignition switch. Raise hood.
2. Remove air cleaner components as needed using Figures 3, 4 and 5 as guides.
3. See Traction Unit Operator's Manual for air cleaner service and maintenance procedures.

Installation (Fig. 3)

IMPORTANT: Any leaks in the air filter system will allow dirt into engine and will cause serious engine damage. Make sure that all air cleaner components are in good condition and are properly secured during assembly.

1. Assemble air cleaner system using Figures 3, 4 and 5 as guides.
 - A. If indicator and adapter were removed from air cleaner housing, apply thread sealant to adapter before installing adapter and indicator to housing.
 - B. Make sure that vacuator valve is pointed down after assembly.

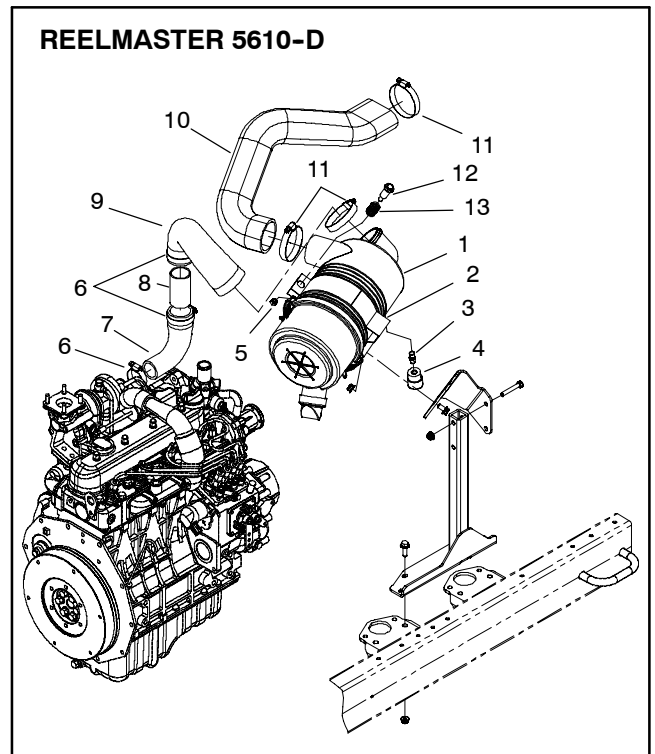

Figure 4

- | | |
|-------------------------|----------------|
| 1. Air cleaner assembly | 8. Spacer |
| 2. Mounting band | 9. Hose |
| 3. Adapter | 10. Hose clamp |
| 4. Indicator | 11. Hose clamp |
| 5. Hex nut | 12. Bolt |
| 6. Hose clamp | 13. Spring |
| 7. Hose | |

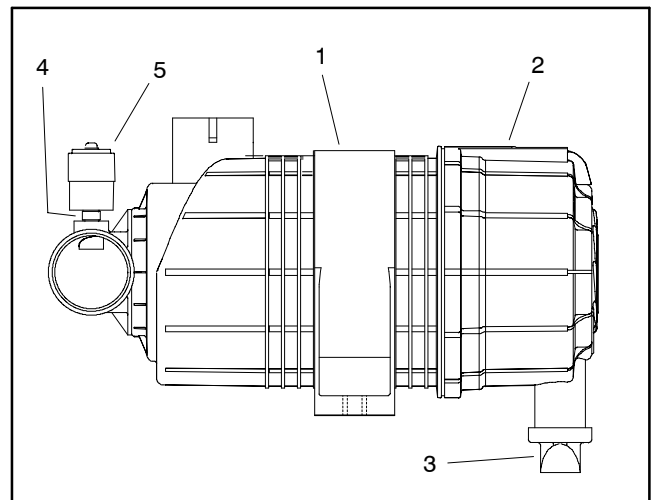

Figure 5

- | | |
|-------------------|--------------|
| 1. Mounting band | 4. Adapter |
| 2. Cover | 5. Indicator |
| 3. Vacuator valve | |

Exhaust System

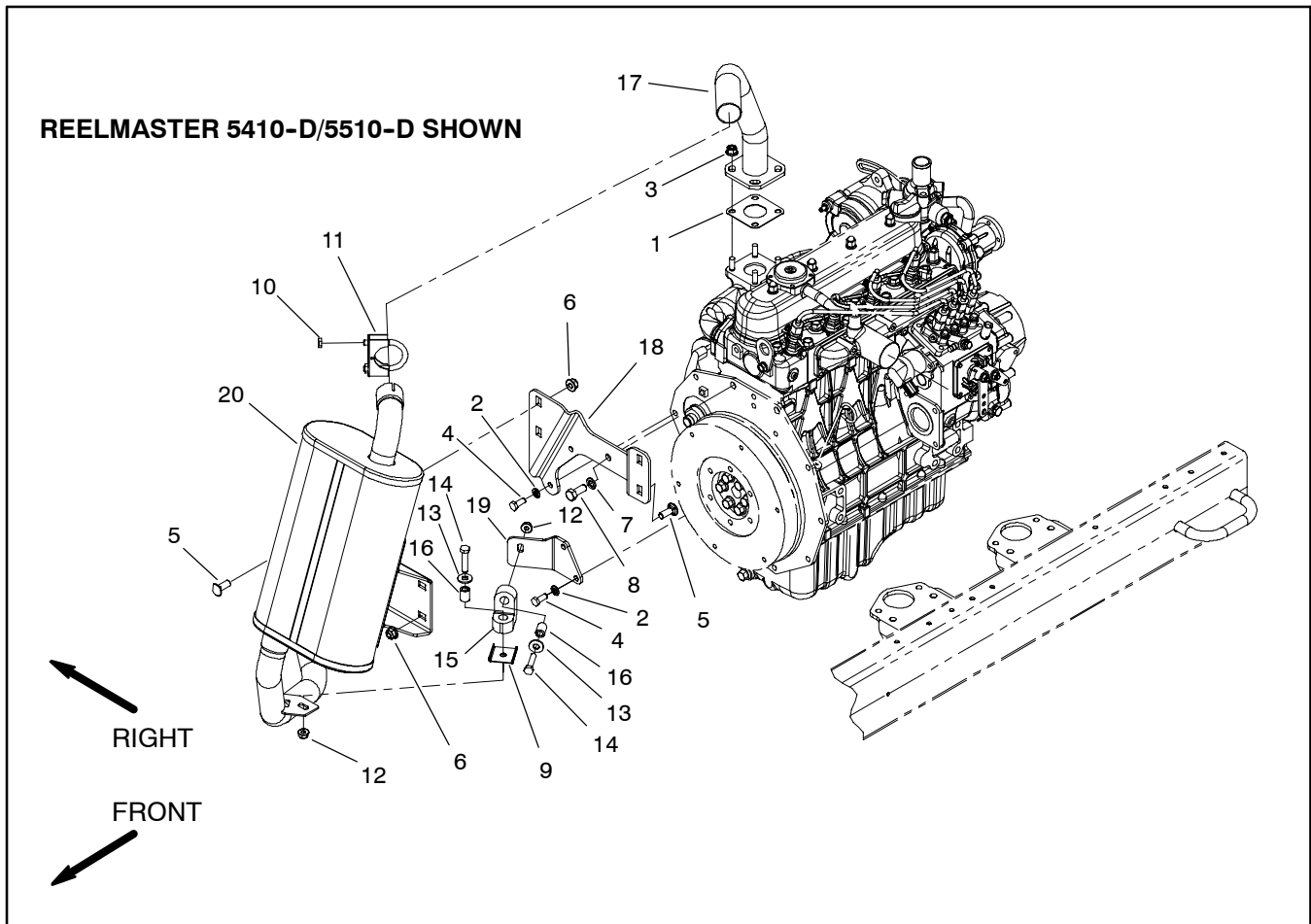

Figure 6

- | | | |
|----------------------------|--------------------------|-----------------------|
| 1. Gasket | 8. Cap screw | 15. Rubber hanger |
| 2. Lock washer (4 used) | 9. Isolator plate | 16. Spacer (2 used) |
| 3. Flange nut (4 used) | 10. Hex nut (2 used) | 17. Exhaust header |
| 4. Cap screw (4 used) | 11. Clamp | 18. Support bracket |
| 5. Carriage screw (4 used) | 12. Flange nut (2 used) | 19. Tail pipe bracket |
| 6. Flange nut (4 used) | 13. Flat washer (2 used) | 20. Muffler |
| 7. Lock washer | 14. Cap screw (2 used) | |

NOTE: The models in the Reelmaster 5010 Series have a very similar exhaust system. The exhaust system removal and installation procedure is the same for all models.

Removal (Fig. 6)

1. Park machine on a level surface, lower cutting units, stop engine, engage parking brake and remove key from the ignition switch. Raise hood.

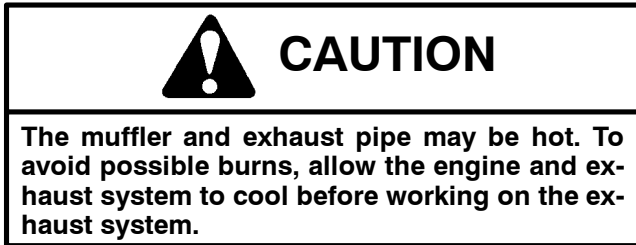

2. Remove exhaust system using Figure 6 as a guide.

Installation (Fig. 6)

NOTE: Make sure muffler flange and exhaust manifold sealing surfaces are free of debris or damage that may prevent a tight seal.

1. Place new muffler gasket on the exhaust manifold. Install exhaust pipe to manifold and secure with four (4) flange nuts.

IMPORTANT: Finger tighten all exhaust system fasteners before tightening so that there is no preload on the exhaust system due to exhaust system assembly.

2. Install exhaust system to the engine using Figure 6 as a guide. Finger tighten all fasteners until all exhaust system components have been installed. Then, fully tighten fasteners to secure exhaust system.

Radiator

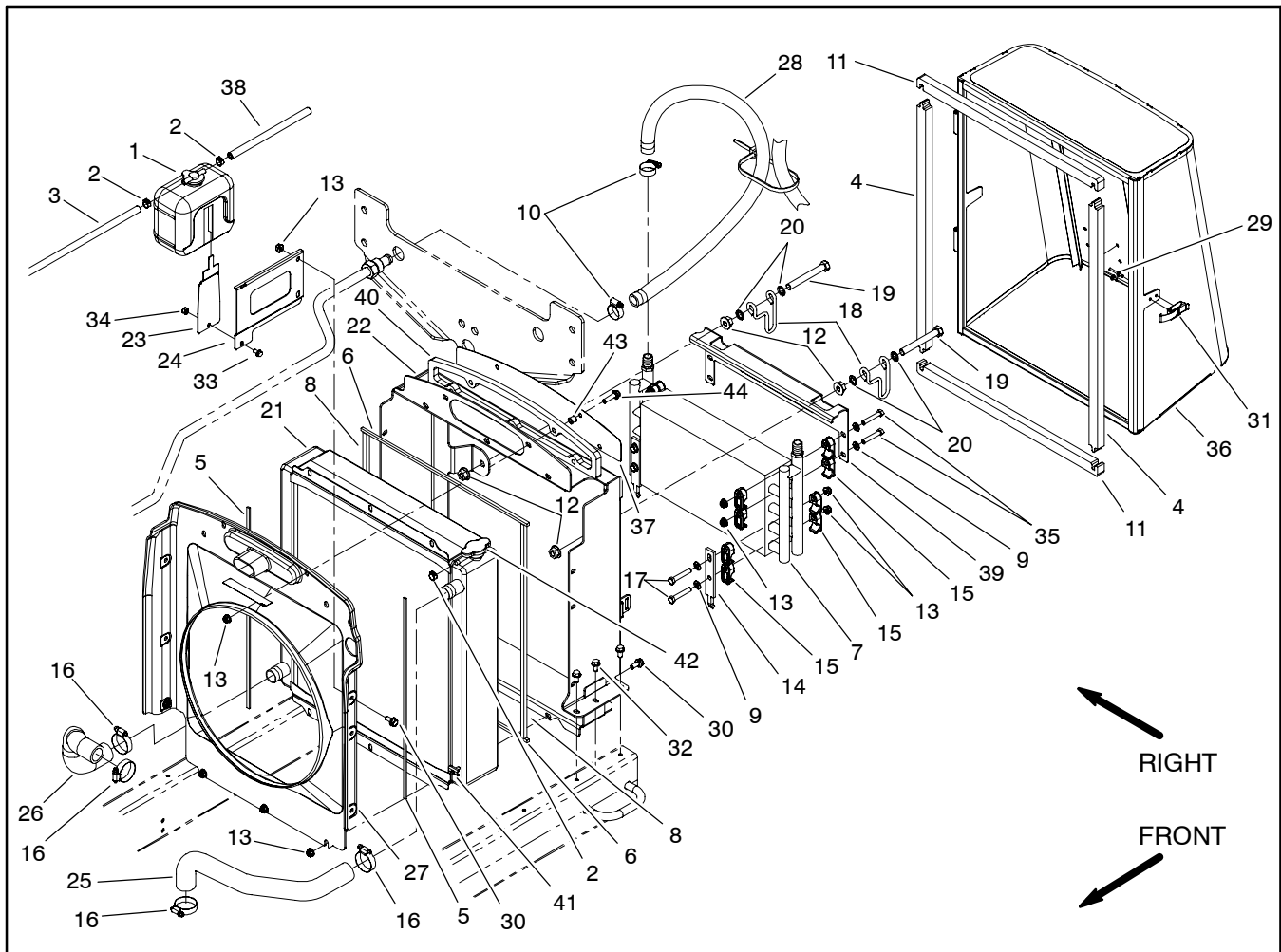

Figure 7

- | | | |
|-------------------------------------|--------------------------------|--------------------------------|
| 1. Overflow bottle | 16. Hose clamp (4 used) | 31. Draw latch |
| 2. Hose clamp (3 used) | 17. Cap screw (4 used) | 32. Washer head screw (6 used) |
| 3. Hose | 18. Clamp (2 used) | 33. Flange head screw |
| 4. Foam seal (2 used) | 19. Cap screw (2 used) | 34. Lock nut |
| 5. Foam seal (2 used) | 20. Washer (4 used) | 35. Cap screw (4 used) |
| 6. Foam seal (2 used) | 21. Radiator | 36. Screen |
| 7. Oil cooler | 22. Radiator frame | 37. Intake screen |
| 8. Foam seal (2 used) | 23. Reservoir bracket | 38. Hose |
| 9. Flat washer (8 used) | 24. Bracket | 39. Oil cooler bracket |
| 10. Hose clamp (4 used) | 25. Hose | 40. Foam seal |
| 11. Foam seal (2 used) | 26. Hose | 41. Draincock |
| 12. Flange nut (4 used) | 27. Fan shroud | 42. Radiator cap |
| 13. Flange nut (22 used) | 28. Hose (2 used) | 43. Spacer (5 used) |
| 14. Oil cooler mount plate (2 used) | 29. Rivet (2 used) | 44. Flange head screw (5 used) |
| 15. Oil cooler clamp (16 used) | 30. Flange head screw (9 used) | |

NOTE: Three (3) radiators are used on Reelmaster 5010 series machines. Reelmaster 5410 and 5510 machines use the same radiator. Reelmaster 5210 and 5610 machines use different radiators. All models use a similar procedure for radiator removal and installation.

Removal (Fig. 7)

1. Park machine on a level surface, lower cutting units, stop engine, engage parking brake and remove key from the ignition switch.
2. Raise the hood.



CAUTION

Do not open radiator cap or drain coolant if the radiator or engine is hot. Pressurized, hot coolant can escape and cause burns.

Ethylene-glycol antifreeze is poisonous. Dispose of coolant properly, or store it in a properly labeled container away from children and pets.

3. Drain coolant from radiator.
 - A. Slowly remove radiator cap from the radiator.
 - B. Place drain pan below the radiator draincock located on the bottom of the radiator. Make sure that drain pan is large enough to hold cooling system contents (see Specifications in this Chapter).
 - C. Loosen draincock and allow coolant to drain from radiator.
4. Remove screen from machine.
5. Disconnect radiator hoses (upper and lower) from the radiator.
6. Loosen hose clamp and remove overflow hose from radiator fill opening.
7. Remove two (2) flange head screws and flange nuts that secure coolant reservoir and brackets to fan shroud. Carefully position reservoir and brackets away from the fan shroud.
8. Remove five (5) flange head screws and flange nuts that secure air intake screen (item 37) to machine. Remove screen and foam seal (item 42). Locate and retrieve five (5) spacers (item 43).
9. Remove flange head screws and flange nuts that secure fan shroud and radiator to radiator frame. Position fan shroud away from the radiator.
10. Carefully pull radiator assembly from the machine. Plug radiator and hose openings to prevent contamination.
11. Inspect all foam seals placed between radiator, fan shroud and radiator frame. Replace damaged foam seals.

Installation (Fig. 7)

1. Remove plugs placed in radiator and hose openings during the removal procedure.
2. Carefully position radiator assembly to the radiator support. Position fan shroud to the radiator.

3. Secure fan shroud and radiator to radiator frame with removed flange head screws and flange nuts. Make sure that at least .250" (6.4 mm) clearance exists at all points between shroud opening and fan.
4. Position coolant reservoir and brackets to the fan shroud. Secure reservoir to fan shroud and radiator frame with two (2) flange head screws and flange nuts.
5. Place spacers (item 43) into holes in foam seal (item 42). Position foam seal and air intake screen (item 37) to radiator frame. Secure screen to machine with five (5) flange head screws and flange nuts.
6. Connect upper and lower radiator hoses to radiator and secure with clamps.
7. Connect overflow hose to radiator fill opening and secure with hose clamp.
8. Make sure radiator draincock is closed (threaded out fully). Fill radiator with coolant.
9. Lower hood. Install screen to rear of machine.

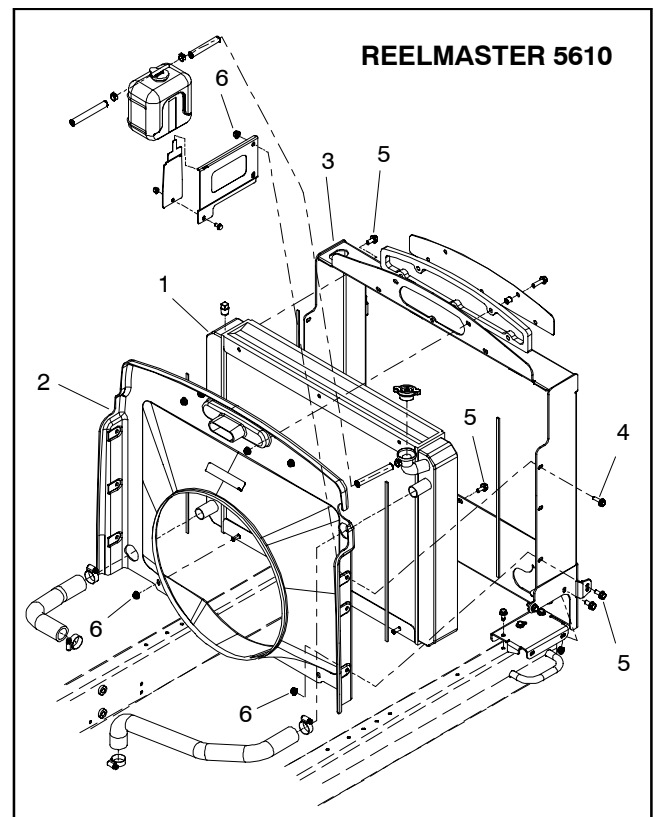

Figure 8

- | | |
|-----------------------|----------------------|
| 1. Radiator (RM 5610) | 4. Flange head screw |
| 2. Fan shroud | 5. Flange head screw |
| 3. Radiator frame | 6. Flange nut |

Engine

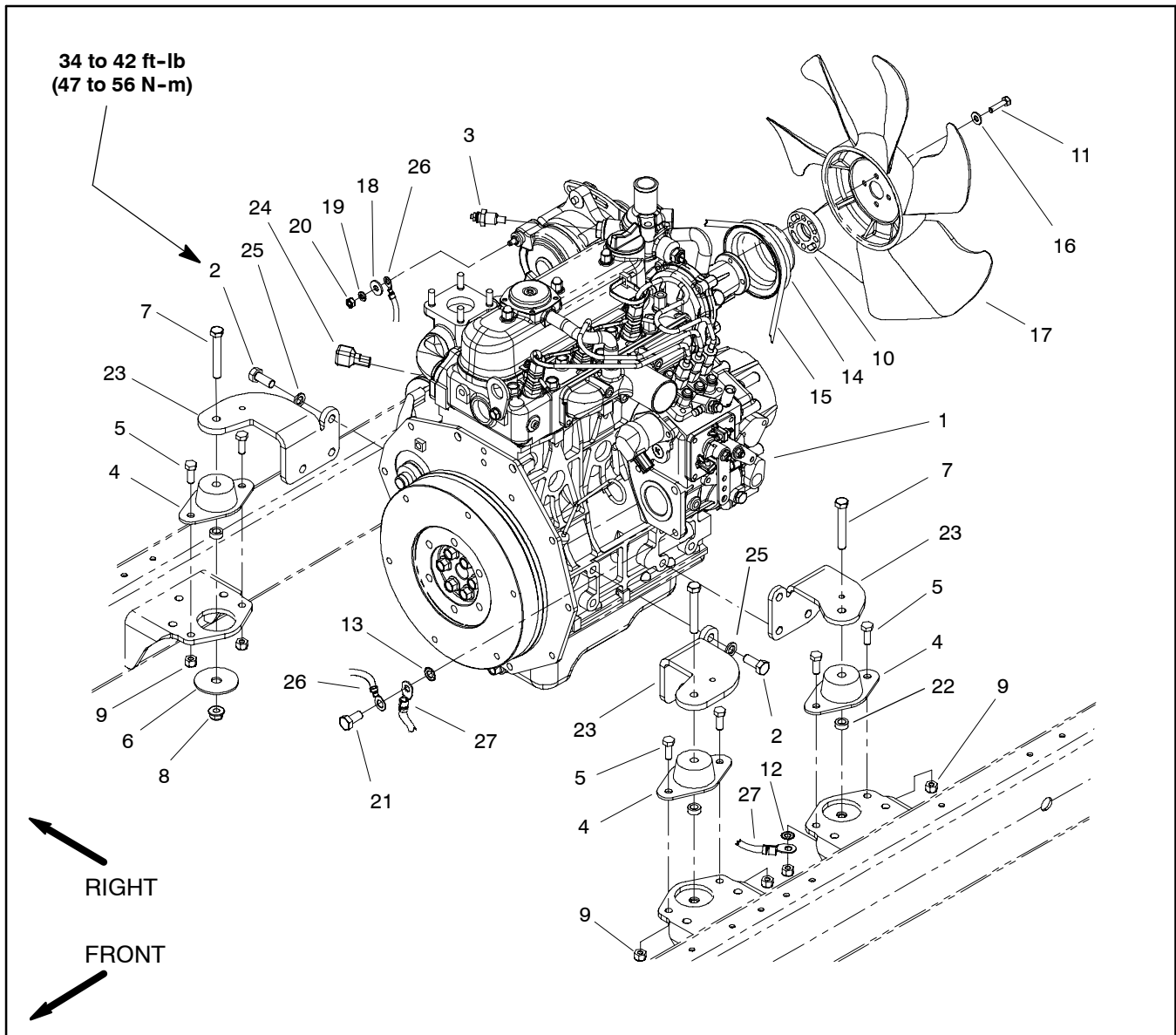

Figure 9

- | | | |
|---------------------------------|--------------------------|-----------------------------|
| 1. Engine assembly | 10. Fan spacer | 19. Spring washer |
| 2. Cap screw (12 used) | 11. Cap screw (4 used) | 20. Hex nut |
| 3. Temperature sender | 12. Lock washer | 21. Cap screw |
| 4. Engine mount (4 used) | 13. Lock washer | 22. Spacer (4 used) |
| 5. Cap screw (2 used per mount) | 14. Pulley | 23. Engine bracket (4 used) |
| 6. Snubbing washer (4 used) | 15. V-belt | 24. Diode assembly |
| 7. Cap screw (4 used) | 16. Flat washer (4 used) | 25. Lock washer (12 used) |
| 8. Flange nut (4 used) | 17. Cooling fan | 26. Engine wire harness |
| 9. Lock nut (2 used per mount) | 18. Flat washer | 27. Negative battery cable |

NOTE: The engine removal and installation procedure is similar for all models in the Reelmaster 5010 Series.

Removal (Fig. 9)

1. Park machine on a level surface, lower cutting units, stop engine and remove key from the ignition switch. Chock wheels to keep the machine from moving.
2. Open hood.
3. Disconnect negative (-) and then positive (+) battery cables from the battery.



CAUTION

Do not open radiator cap or drain coolant if the radiator or engine is hot. Pressurized, hot coolant can escape and cause burns.

Ethylene-glycol antifreeze is poisonous. Dispose of coolant properly, or store it in a properly labeled container away from children and pets.

4. Drain coolant from radiator (see Radiator Removal in this section).
5. Remove air cleaner from machine (see Air Cleaner Removal in this section).
6. Remove exhaust system from machine (see Exhaust System Removal in this section).
7. Remove throttle cable from injector pump (Fig. 10):
 - A. Remove cap screw that secures throttle cable end to swivel in speed control lever.
 - B. Loosen throttle cable clamp and remove cable from clamp. Slide throttle cable end from swivel.
 - C. Position throttle cable away from the engine.
8. Disconnect hoses from engine:
 - A. Loosen clamps and remove upper and lower radiator hoses from the engine.
 - B. At injector pump, loosen hose clamp and disconnect supply fuel hose from the injector pump fitting (Fig. 11).
 - C. Loosen hose clamp and disconnect fuel return hose from front injector body (Fig. 11).
 - D. Plug disconnected hoses and engine openings to prevent leakage and contamination. Position disconnected hoses away from engine.

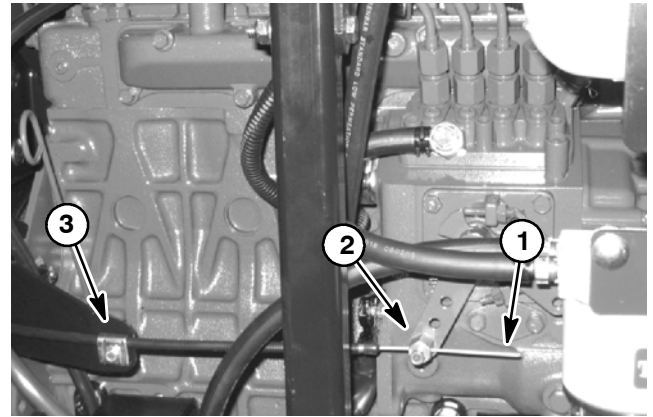

Figure 10

1. Throttle cable end
2. Swivel
3. Cable clamp

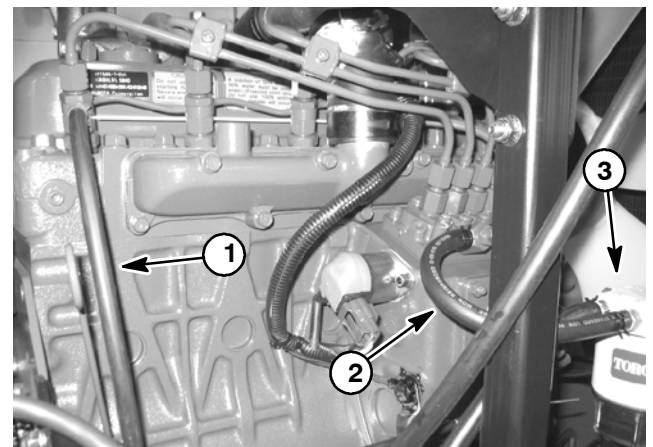

Figure 11

1. Fuel return hose
2. Fuel supply hose
3. Fuel/water filter

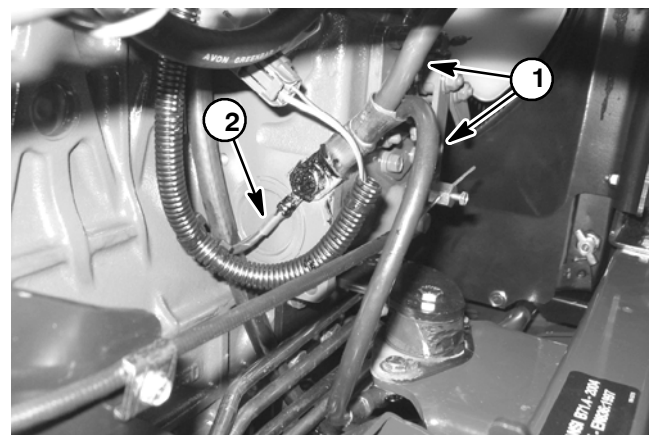

Figure 12

1. Negative battery cable
2. Harness ground

9. Disconnect hydraulic transmission drive shaft from engine (see Hydraulic Transmission Drive Shaft Removal in the Service and Repairs section of Chapter 4 – Hydraulic System). Support drive shaft away from engine.

10. Disconnect wire harness connectors from the following engine components:

NOTE: Before disconnecting wire harness connectors, label all electrical leads for assembly purposes.

- A. Alternator connector and stud.
- B. Oil pressure switch located near the engine oil filter.
- C. Connector, fusible link connector and positive battery cable from the starter motor.
- D. High temperature shut down switch and temperature sender located on the water pump housing.
- E. Fuel stop solenoid on injector pump.
- F. Negative battery cable and harness ground from injector pump (Fig. 12).
- G. Glow plug strip.

11. Remove engine from machine:

- A. Attach short section of chain between lift tabs located on each end of the cylinder head.
- B. Connect a hoist or chain fall at the center of the short section of chain. Apply enough tension on the short chain so that the engine will be supported.
- C. Remove fasteners that secure the engine (with brackets) to the engine mounts.

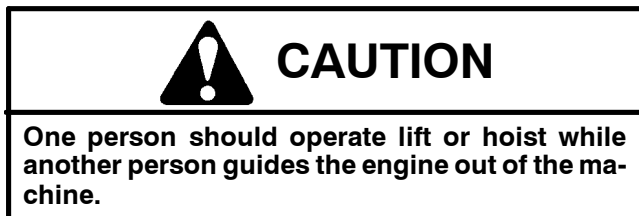

IMPORTANT: Make sure to not damage the engine, fuel hoses, hydraulic lines, electrical harness, radiator, battery or other parts while removing the engine.

- D. Raise engine and remove toward front of machine.

12. If necessary, remove engine brackets from engine.

Installation (Fig. 9)

1. Locate machine on a level surface with cutting units lowered and key removed from the ignition switch. Chock wheels to keep the machine from moving.

2. Make sure that all parts removed from the engine during maintenance or rebuilding are installed to the engine.

3. If engine brackets were removed from the engine, secure brackets to engine with lock washers and cap screws. Torque cap screws from **34 to 42 ft-lb (47 to 56 N-m)**.

4. Install engine to machine.

A. Attach short section of chain between lift tabs located on each end of the cylinder head

B. Connect a hoist or chain fall at the center of the short section of chain. Apply enough tension on the short chain so that the engine can be supported.

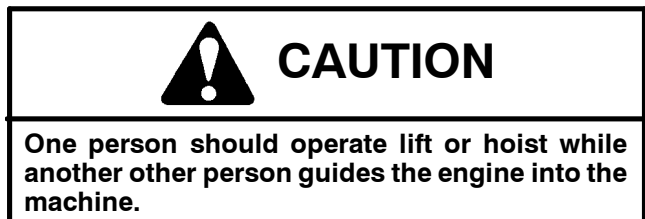

IMPORTANT: Make sure to not damage the engine, fuel hoses, hydraulic lines, electrical harness, radiator, battery or other parts while installing the engine.

C. Lower engine to the machine frame. Make sure fastener holes of the engine brackets are aligned with the holes in the engine mounts.

D. Insert cap screw down through each engine bracket and mount. Place spacer, snubbing washer and then flange nut on four (4) cap screws. Tighten fasteners to secure engine to engine mounts.

5. Connect hydraulic transmission drive shaft to engine (see Hydraulic Transmission Drive Shaft Installation in the Service and Repairs section of Chapter 4 – Hydraulic System).

6. Connect all wire harness connectors to correct engine components.

7. Remove plugs installed in hoses during disassembly. Connect hoses to the engine:
 - A. Connect fuel supply and fuel return hoses to engine fittings (Fig. 11). Secure with hose clamps.
 - B. Connect upper and lower radiator hoses to the engine. Secure with hose clamps.
8. Connect throttle cable to injector pump (Fig. 10):
 - A. Route throttle cable to injector pump on engine.
 - B. Install the throttle cable end into the swivel in speed control lever. Secure cable end with cap screw.
 - C. Position cable under cable clamp.
 - D. Adjust throttle control (see Adjust Throttle Control in the Adjustments section of this chapter).
9. Install air cleaner (see Air Cleaner Installation in this section).
10. Install exhaust system to machine (see Exhaust System Installation in this section).
11. Add coolant to radiator.
12. Check engine oil level and adjust if needed.
13. Connect positive (+) and then negative (-) battery cables to the battery.
14. Bleed fuel system.
15. Close hood.

This page is intentionally blank.



Hydraulic System

Hydraulic System

Table of Contents

SPECIFICATIONS	2	SERVICE AND REPAIRS	58
GENERAL INFORMATION	3	General Precautions for Removing and Installing	
Traction Unit Operator's Manual	3	Hydraulic System Components	58
Check Hydraulic Fluid	3	Check Hydraulic Lines and Hoses	59
Towing Traction Unit	3	Flush Hydraulic System	60
Hydraulic Hoses	4	Filtering Closed- Loop Traction Circuit	61
Hydraulic Fitting Installation	4	Hydraulic System Start- up	62
Relieving Hydraulic System Pressure	6	Hydraulic Reservoir	64
Traction Circuit Component Failure	6	Hydraulic Pump Drive Shaft	66
HYDRAULIC SCHEMATICS	7	Hydraulic Pump Assembly	68
HYDRAULIC FLOW DIAGRAMS	8	Piston (Traction) Pump Service	72
Traction Circuit	8	Gear Pump Service	74
Mow Circuit	10	Front Wheel Motor	76
Lift Circuit: Raise Cutting Units	12	Wheel Motor Service (Parker)	80
Lift Circuit: Lower Cutting Units	14	Wheel Motor Service (Eaton)	81
Steering Circuit	16	Mow Control Manifold	82
SPECIAL TOOLS	18	Mow Control Manifold Service	84
TROUBLESHOOTING	22	Lift Control Manifold	88
General Hydraulic System Problems	22	Lift Control Manifold Service	90
Traction Circuit Problems	23	CrossTrax™ AWD (Optional Kit) Manifold	92
Mow Circuit Problems	24	CrossTrax™ AWD (Optional Kit) Manifold	
Lift Circuit Problems	25	Service	94
Steering Circuit Problems	26	Cutting Reel Motor	96
TESTING	28	Cutting Reel Motor Service (Bosch and	
Traction Circuit Relief Valve (R3) and (R4)		Sauer- Danfoss)	98
Pressure Test	30	Cutting Reel Motor Service (Casappa)	102
Traction Circuit Charge Pressure Test	32	Lift Cylinder	106
Gear Pump (P3) Flow Test	34	Lift Cylinder Service	108
Front Wheel Motor Efficiency Test	36	Steering Control Valve	110
Piston (Traction) Pump Flow Test	38	Steering Control Valve Service	112
Relief Valve (R1) and (R2) Pressure Test	40	Steering Cylinder	114
Gear Pump (P1) and (P2) Flow Test	42	Steering Cylinder Service	116
Reel Drive Motor Efficiency Test	44	Oil Cooler	118
Reel Drive Motor Cross- Over Relief Pressure		DANFOSS LPV CLOSED CIRCUIT AXIAL	
Test (Reelmaster 5510 and 5610)	46	PISTON PUMPS REPAIR MANUAL	
Lift Relief Valve (R6) Pressure Test	48	DANFOSS LPV CLOSED CIRCUIT AXIAL	
Gear Pump (P4) Flow Test	50	PISTON PUMPS SERVICE INSTRUCTIONS	
Lift Cylinder Internal Leakage Test	52	PARKER TORQMOTOR™ SERVICE PROCEDURE	
Steering Relief Valve (R10) Pressure Test	54	(TC, TB, TE, TJ, TF, TG, TH AND TL SERIES)	
Steering Cylinder Internal Leakage Test	56	EATON DELTA MOTORS PARTS AND REPAIR	
		MANUAL	
		DANFOSS STEERING UNIT TYPE OSPM	
		SERVICE MANUAL	

Specifications

Item	Description
Piston (Traction) Pump Maximum Pump Displacement (per revolution)	Sauer- Danfoss, LPV Closed Circuit Axial Piston Design 2.14 Cubic Inches (35 cc)
Gear Pump Section P1/P2 Displacement (per revolution) (RM 5210 & 5410) Section P1/P2 Displacement (per revolution) (RM 5510 & 5610) Section P3 Displacement (per revolution) (all models) Section P4 Displacement (per revolution) (all models)	Casappa 4 section, positive displacement gear type pump 0.50 Cubic Inches (8.3 cc) 0.66 Cubic Inches (10.8 cc) 0.37 Cubic Inches (6.1 cc) 0.24 Cubic Inches (3.9 cc)
Charge Circuit Relief (R5) Pressure	200 PSI (14 bar)
Traction Circuit Relief Pressure: Forward (R3) and Reverse (R4)	3625 PSI (250 bar)
Front Wheel Motors (see NOTE below)	Parker orbital rotor motor, TG Series Eaton geroler motor, Delta Series
Rear Wheel Motors (if equipped)	Parker orbital rotor motor, TL Series
Mow Circuit Relief Pressure Rear Mow Circuit (R1) Front Mow Circuit (R2)	2500 PSI (172 bar) 3500 PSI (241 bar)
Cutting Unit Motor (RM 5210 & RM 5410) Displacement (per revolution)	Sauer- Danfoss gear motor 0.73 Cubic Inches (12 cc)
Cutting Unit Motor (RM 5510 & RM 5610) Displacement (per revolution) Cross Over Relief Valve Pressure	Bosch gear motor 1.18 Cubic Inches (19.3 cc) 1500 PSI (103 bar)
Steering Valve	Sauer- Danfoss Steering Unit, Type OSPMS
Steering Circuit Relief (R10) Pressure	1000 PSI (69 bar)
Lift Circuit Relief (R6) Pressure	2000 PSI (138 bar)
Lift Circuit Lower Relief (R7) Pressure	500 PSI (34 bar)
Hydraulic Filter (Transmission and Steering Circuits)	Spin- on Cartridge Type with 50 PSI (3.4 bar) Relief in Adapter
Hydraulic Filter (Mow and Lift Circuits)	Spin- on Cartridge Type with 50 PSI (3.4 bar) Relief in Adapter (filter adapter includes filter change indicator)
Hydraulic Oil	See Traction Unit Operator's Manual
Hydraulic Reservoir Capacity	11 U.S. Gallons (41.6 L)

NOTE: Machines produced with serial number below 311000600 were produced with Parker brand front wheel motors. Machines with serial number above 311000600 were produced with Eaton brand front wheel motors. If Parker brand wheel motors have been replaced, the replacement wheel motors may have been Eaton brand.

General Information

Traction Unit Operator's Manual

The Traction Unit Operator's Manual provides information regarding the operation, general maintenance and maintenance intervals for your Reelmaster machine. Refer to that publication for additional information when servicing the machine.

Check Hydraulic Fluid

The hydraulic system on Reelmaster 5010 series machines is designed to operate on high quality hydraulic fluid. The hydraulic system reservoir holds approximately 11 gallons (41.6 liters) of hydraulic fluid. **Check level of hydraulic fluid daily.** See Traction Unit Operator's Manual for fluid level checking procedure and hydraulic oil recommendations.

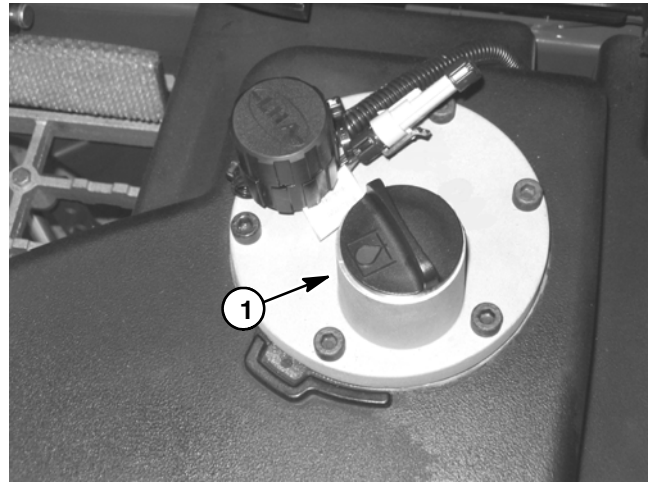

Figure 1
1. Hydraulic reservoir cap

Towing Traction Unit

IMPORTANT: If towing limits are exceeded, severe damage to the piston (traction) pump may occur.

If it becomes necessary to tow or push the machine, tow or push at a speed below 3 mph (4.8 kph), and for a very short distance. If the machine needs to be moved a considerable distance, machine should be transported on a trailer. The piston (traction) pump is equipped with a bypass valve that needs to be loosened for towing or pushing (Fig. 2). See Traction Unit Operator's Manual for Towing Procedures.

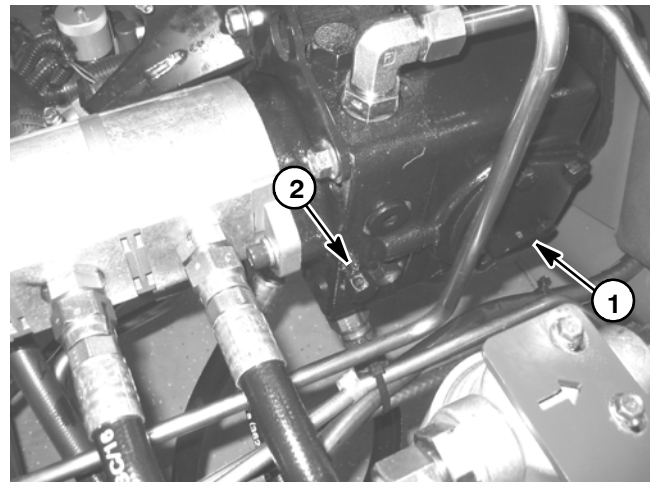

Figure 2
1. Piston (traction) pump 2. Bypass valve

Hydraulic Hoses

Hydraulic hoses are subject to extreme conditions such as pressure differentials during operation and exposure to weather, sun, chemicals, very warm storage conditions or mishandling during operation and maintenance. These conditions can cause damage or premature deterioration. Some hoses are more susceptible to these conditions than others. Inspect the hoses frequently for signs of deterioration or damage.

When replacing a hydraulic hose, be sure that the hose is straight (not twisted) before tightening the fittings. This can be done by observing the imprint on the hose. Use two wrenches; hold the hose straight with one wrench and tighten the hose swivel nut onto the fitting with the other wrench.



WARNING

Before disconnecting or performing any work on hydraulic system, relieve all pressure in system. Stop engine; lower or support all cutting units.

Keep body and hands away from pin hole leaks or nozzles that eject hydraulic fluid under high pressure. Use paper or cardboard, not hands, to search for leaks. Hydraulic fluid escaping under pressure can have sufficient force to penetrate the skin and cause serious injury. If fluid is injected into the skin, it must be surgically removed within a few hours by a doctor familiar with this type of injury. Gangrene may result from such an injury.

Hydraulic Fitting Installation

O-Ring Face Seal

1. Make sure both threads and sealing surfaces are free of burrs, nicks, scratches or any foreign material.
2. Make sure the O-ring is installed and properly seated in the groove. It is recommended that the O-ring be replaced any time the connection is opened.
3. Lubricate the O-ring with a light coating of oil.
4. Put the tube and nut squarely into position on the face seal end of the fitting and tighten the nut until finger tight.
5. Mark the nut and fitting body. Hold the body with a wrench. Use another wrench to tighten the nut to the correct Flats From Finger Tight (F.F.F.T.). The markings on the nut and fitting body will verify that the connection has been tightened.

Size	F.F.F.T.
4 (1/4 in. nominal hose or tubing)	0.75 ± 0.25
6 (3/8 in.)	0.75 ± 0.25
8 (1/2 in.)	0.75 ± 0.25
10 (5/8 in.)	1.00 ± 0.25
12 (3/4 in.)	0.75 ± 0.25
16 (1 in.)	0.75 ± 0.25

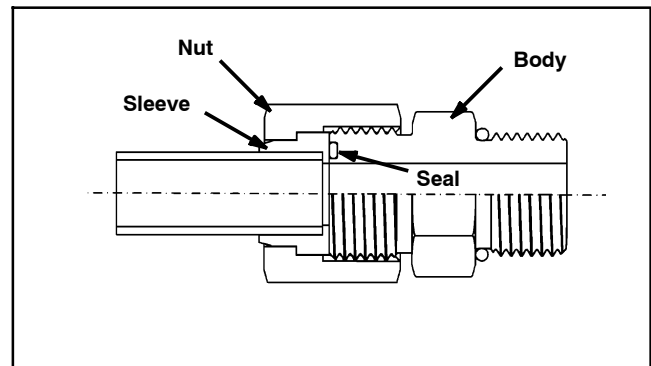

Figure 3

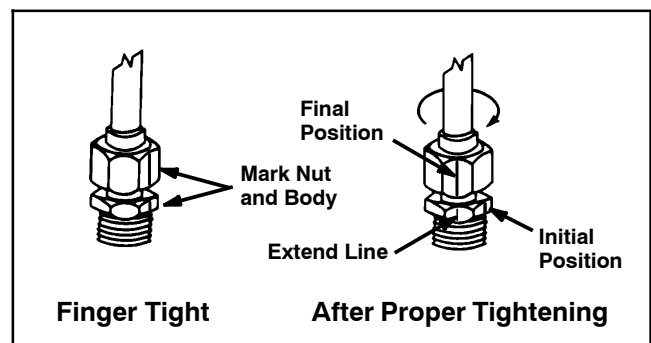

Figure 4

SAE Straight Thread O-Ring Port - Non-adjustable

1. Make sure both threads and sealing surfaces are free of burrs, nicks, scratches or any foreign material.
2. Always replace the O-ring seal when this type of fitting shows signs of leakage.
3. Lubricate the O-ring with a light coating of oil.
4. Install the fitting into the port and tighten it down full length until finger tight.
5. Tighten the fitting to the correct Flats From Finger Tight (F.F.F.T.).

Size	F.F.F.T.
4 (1/4 in. nominal hose or tubing)	1.00 ± 0.25
6 (3/8 in.)	1.50 ± 0.25
8 (1/2 in.)	1.50 ± 0.25
10 (5/8 in.)	1.50 ± 0.25
12 (3/4 in.)	1.50 ± 0.25
16 (1 in.)	1.50 ± 0.25

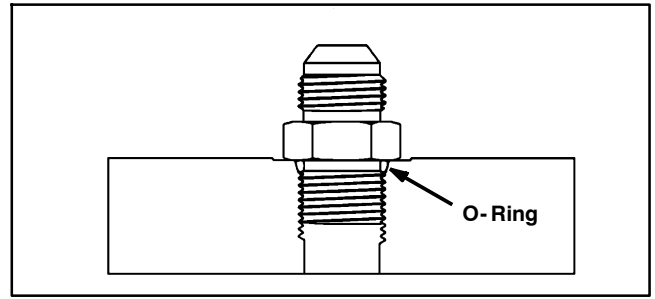

Figure 5

SAE Straight Thread O-Ring Port - Adjustable

1. Make sure both threads and sealing surfaces are free of burrs, nicks, scratches or any foreign material.
2. Always replace the O-ring seal when this type of fitting shows signs of leakage.
3. Lubricate the O-ring with a light coating of oil.
4. Turn back the jam nut as far as possible. Make sure the back up washer is not loose and is pushed up as far as possible (Step 1).
5. Install the fitting into the port and tighten finger tight until the washer contacts the face of the port (Step 2).
6. To put the fitting in the desired position, unscrew it by the required amount, but no more than one full turn (Step 3).
7. Hold the fitting in the desired position with a wrench and turn the jam nut with another wrench to the correct Flats From Finger Tight (F.F.F.T.) (Step 4).

Size	F.F.F.T.
4 (1/4 in. nominal hose or tubing)	1.00 ± 0.25
6 (3/8 in.)	1.50 ± 0.25
8 (1/2 in.)	1.50 ± 0.25
10 (5/8 in.)	1.50 ± 0.25
12 (3/4 in.)	1.50 ± 0.25
16 (1 in.)	1.50 ± 0.25

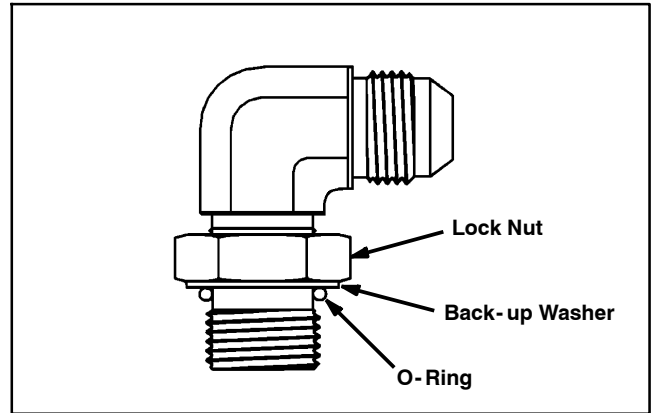

Figure 6

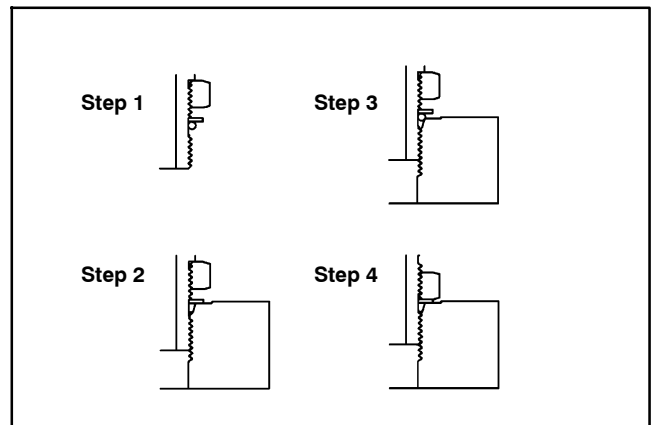

Figure 7

Relieving Hydraulic System Pressure

Before disconnecting or performing any work on the hydraulic system, all pressure in the hydraulic system must be relieved. Park machine on a level surface, lower cutting units fully, stop engine and engage parking brake.

To relieve hydraulic pressure in traction circuit, move traction pedal to both forward and reverse directions. To relieve hydraulic pressure in steering circuit, rotate steering wheel in both directions.

To relieve hydraulic pressure in lift circuit, start engine and fully lower the cutting units. Turn key switch to OFF and remove key from the ignition switch.

System pressure in cutting circuit is relieved when the cutting units are disengaged.

Traction Circuit Component Failure

The traction circuit on Reelmaster 5010 series machines is a closed loop system that includes the piston (traction) pump and two (2) wheel motors (4 wheel motors on machines equipped with optional CrossTrax™ AWD kit). If a component in the traction circuit should fail, debris and contamination from the failed component will circulate throughout the traction circuit. This contamination can damage other components in the circuit so it must be removed to prevent additional component failure.

If a component failure occurs in the traction circuit, it is recommended that the entire traction circuit be disassembled, drained and thoroughly cleaned to ensure that all contamination is removed from the circuit. If any debris remains in the traction circuit and the machine is operated, the debris can cause additional component failure.

An alternative method of removing traction circuit contamination would be to temporarily install a high pressure hydraulic oil filter (see Special Tools) into the circuit. The filter should be used when connecting hydraulic test gauges in order to test traction circuit components or after replacing a failed traction circuit component (e.g. traction (piston) pump or wheel motor). The filter will ensure that contaminants are removed from the closed loop and thus, do not cause additional component damage.

Once the filter has been placed in the circuit, operate the traction circuit to allow oil flow through the circuit. The filter will remove contamination from the traction circuit during circuit operation. The filter can be removed from the machine after contamination has been removed from the traction circuit.

IMPORTANT: When operating the traction system with the high pressure filter installed, make sure that flow is always directed through the filter before entering a replaced component (e.g. do not press the traction pedal in the reverse direction if the filter is placed for forward direction flow). If flow is reversed, debris from the filter will re-enter the traction circuit.

NOTE: The traction pump case drain could allow traction circuit contamination to contaminate other hydraulic circuits on the machine.

Hydraulic Schematics

The hydraulic schematics for Reelmaster 5010 series machines are located in Chapter 9 - Foldout Drawings.

Hydraulic Flow Diagrams

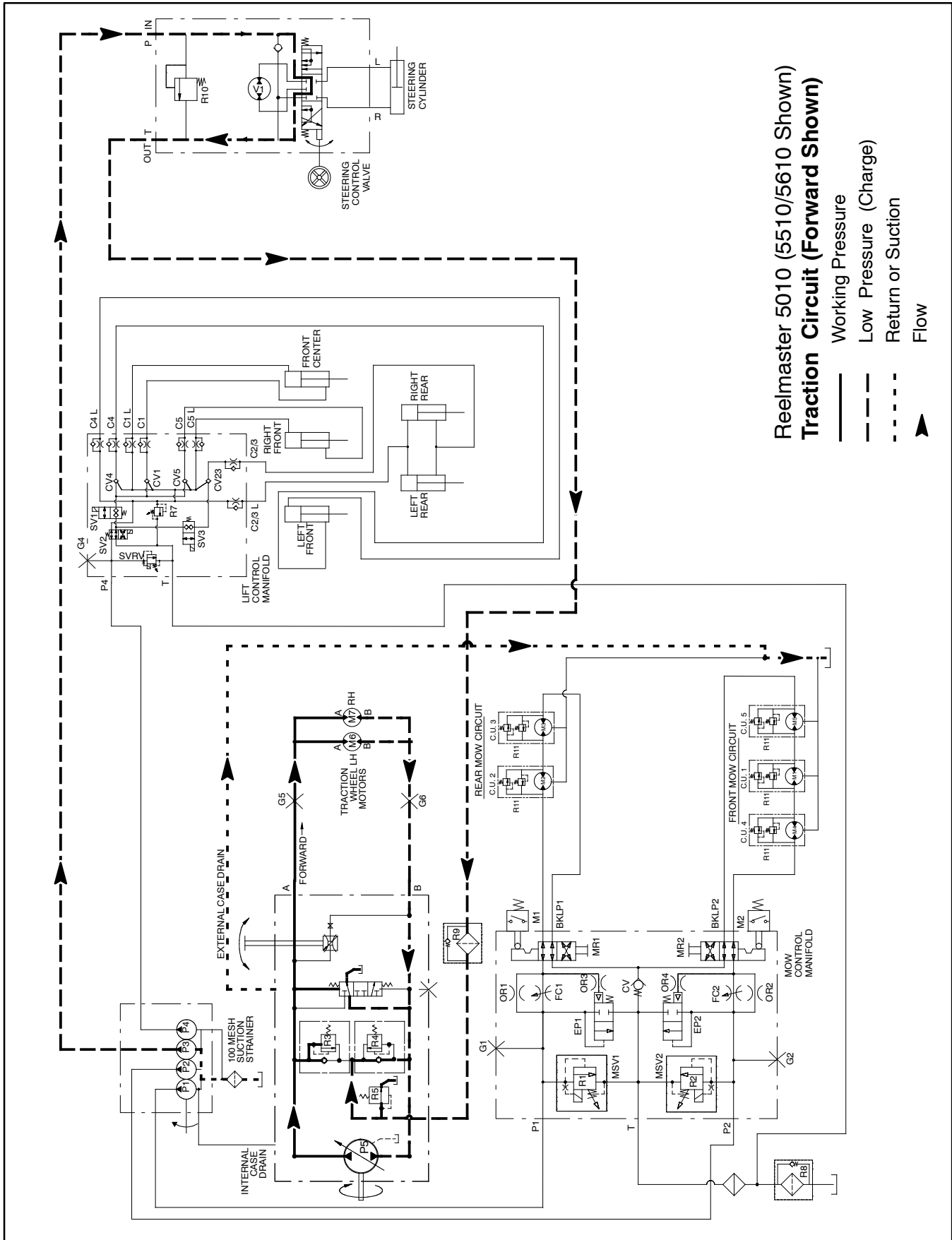

Figure 8

Traction Circuit

The hydraulic traction circuit consists of a variable displacement piston pump (P5) connected in a closed loop, parallel circuit to two (2) orbital roller vane wheel motors. The traction pump input shaft is rotated by a drive shaft that is driven from the engine flywheel.

Traction circuit pressure (forward and reverse) can be measured at test ports located in the hydraulic tubes that connect the front wheel motors.

Forward Direction (Fig. 8)

Pushing the top of the traction pedal angles the traction pump swash plate to create a flow of oil. This oil flow is directed to the wheel motors via hydraulic hoses and tubes to drive the wheels in the forward direction. Forward traction pressure is limited to 3625 PSI (250 bar) by the forward traction relief valve (R3) located in the traction pump.

Oil flowing from the wheel motors returns to the variable displacement pump and is continuously pumped through the closed loop traction circuit as long as the traction pedal is pushed.

The angle of the swash plate determines pump flow and ultimately traction speed. When the traction pedal is depressed a small amount, a small swash plate rotation results in low pump output and lower traction speed. When the traction pedal is depressed fully, the pump swash plate rotates fully to provide maximum pump output and traction speed.

Gear pump section (P3) supplies oil flow for the steering circuit and also provides a constant supply of charge oil to the closed loop traction circuit. This charge oil provides lubrication for traction circuit components and also replenishes traction circuit oil that is lost due to internal leakage in the traction circuit.

Gear pump (P3) takes its suction from the hydraulic reservoir. Charge pump flow is directed to the low pressure side of the closed loop traction circuit. Charge pressure is limited by the charge relief valve (R5) located in the traction pump. The charge relief pressure is 200 PSI (14 bar).

The piston pump (P5) includes a flushing valve (R10) that bleeds off a small amount of hydraulic fluid for cooling of the closed loop traction circuit. The charge system replenishes oil that is bled from the traction circuit by the flushing valve.

Reverse Direction

The traction circuit operates essentially the same in reverse as it does in the forward direction. However, the flow through the circuit is reversed. Pushing the bottom of the traction pedal rotates the traction pump swash plate to create a flow of oil. This oil is directed to the wheel motors to drive the wheels in the reverse direction. Reverse traction pressure is limited to 3625 PSI (250 bar) by the reverse traction relief valve (R4) located in the traction pump.

Oil flowing from the wheel motors returns to the traction pump and is continuously pumped through the closed loop traction circuit as long as the traction pedal is pushed.

The charge circuit and flushing valve (R10) function the same in reverse as they do in the forward direction.

CrossTrax™ AWD (Optional)

On machines equipped with the optional CrossTrax™ AWD kit, four wheel motors are used (Fig. 9). Traction pump flow is directed to the front tires and the opposite rear tires to maximize traction. To reduce tire scuffing when turning, traction system pressure is equalized in the AWD manifold with an orifice and a bi-directional relief valve. Check valves in the AWD manifold allow the rear wheel motors to over run during tight turns.

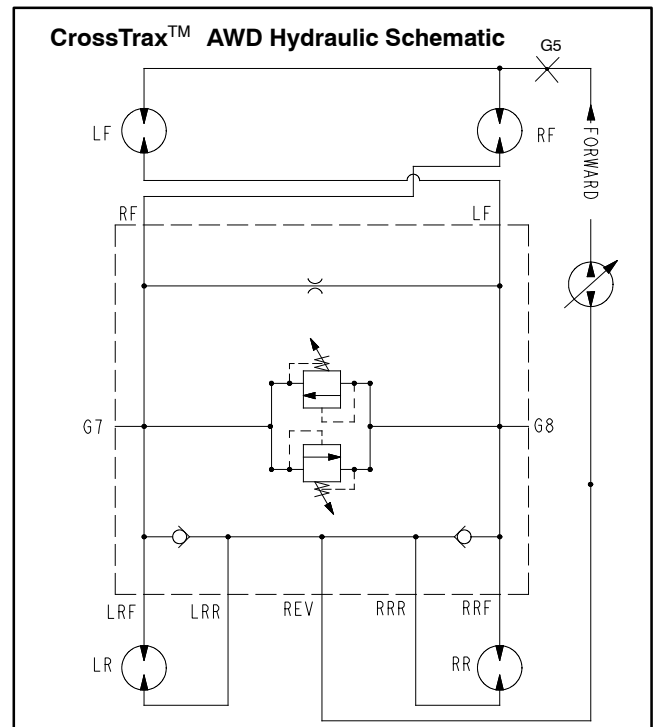

Figure 9

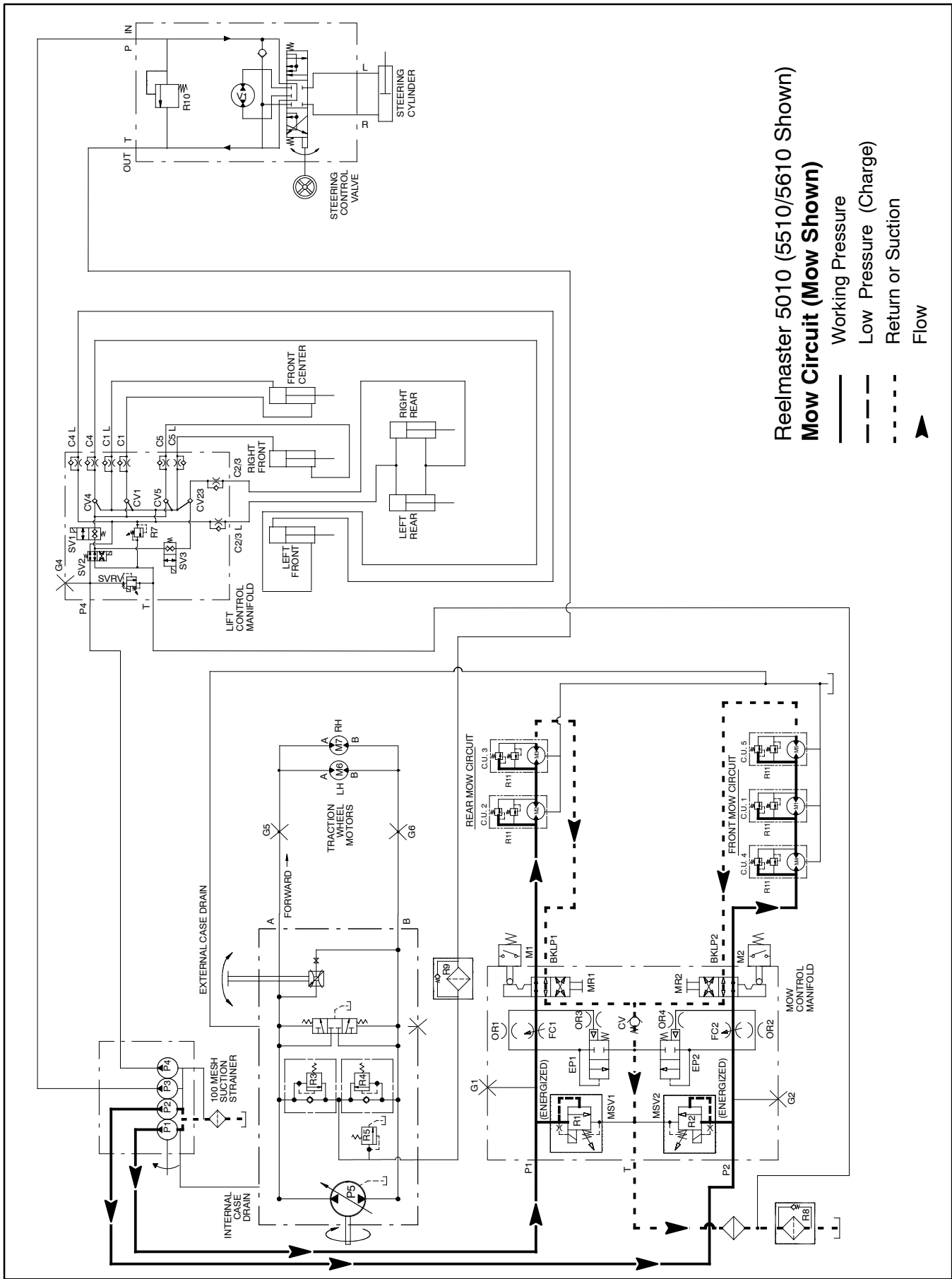

Figure 10

Mow Circuit

A four section gear pump is coupled to the piston (traction) pump. Gear pump sections (P1) and (P2) supply hydraulic flow for the mow circuit. These gear pumps take their suction from the hydraulic reservoir.

The mow control manifold contains two independent control circuits for the front and rear cutting units. Each circuit is supplied by its own pump section. Pump section (P1) supplies hydraulic power to the rear cutting units through mow control manifold port P1, solenoid relief valve (MSV1) and direction valve (MR1). Pump section (P2) supplies the front cutting units through manifold port P2, solenoid relief valve (MSV2) and direction valve (MR2). Both circuits share manifold port T, which drains to the oil cooler, oil filter and hydraulic reservoir.

On the mow circuit supplied by pump section (P1) (rear cutting units), maximum system pressure is limited by solenoid relief valve (R1), which is set at 2500 PSI (172 bar). On the circuit supplied by pump section (P2) (front cutting units), maximum system pressure is limited by solenoid relief valve (R2), which is set at 3500 PSI (241 bar).

On Reelmaster 5510 and 5610 machines, all cutting reel motors are equipped with cross over relief valves to prevent hydraulic component damage in case a cutting reel should stall.

The Electronic Control Module (ECM) uses inputs from various machine switches to determine when solenoid relief valves (MSV1) and (MSV2) are to be energized. The ECM also provides a slight delay in activation of front and rear cutting units.

When solenoid relief valves (MSV1) and (MSV2) are not energized (PTO switch in the OFF position), flow from pump sections (P1) and (P2) is directed out the mow manifold port T and returns to the hydraulic reservoir, by-passing the reel motors.

Mow (Fig. 10)

When solenoid valve (MSV1) is energized by the ECM, pump section (P1) flow enters mow control manifold port

P1 and is directed to reel speed control valve (FC1). Flow through the speed control valve is pressure compensated by logic cartridge valve (EP1). The logic cartridge valve maintains a pressure of 75 PSI (5.2 bar) across the speed control valve. Any excess flow is returned to the hydraulic reservoir. Regulated flow continues through valve (MR1) and out to the rear reel motors to rotate the cutting reels. When valve (MR1) is in the Mow position, the rear reels rotate correctly for mowing. Return oil from the rear reel motors is directed to the reservoir through valve (MR1) and manifold port T.

Mow circuit pressure for the rear cutting units (pump section P1) can be measured at manifold port G1.

When solenoid valve (MSV2) is energized by the ECM, oil flow from port P2 is directed through reel speed control valve (FC2). Flow through the speed control valve is pressure compensated by logic cartridge valve (EP2). The logic cartridge valve maintains a pressure of 75 PSI (5.2 bar) across the speed control valve. Any excess flow is returned to the hydraulic reservoir. Regulated flow continues through valve (MR2) and out to the front reel motors. When valve (MR2) is in the Mow position, the front reels rotate correctly for mowing. Return oil from the front motors is directed to the reservoir through valve (MR2) and manifold port T.

Mow circuit pressure for the front cutting units (pump section P2) can be measured at manifold port G2.

Backlap

During the backlap mode of operation, the reel circuits operate the same as in the Mow mode. When either valve (MR1) or (MR2) is set to the Backlap position, the valve reverses the direction of hydraulic flow through the rear or front reel motors allowing the backlap operation.

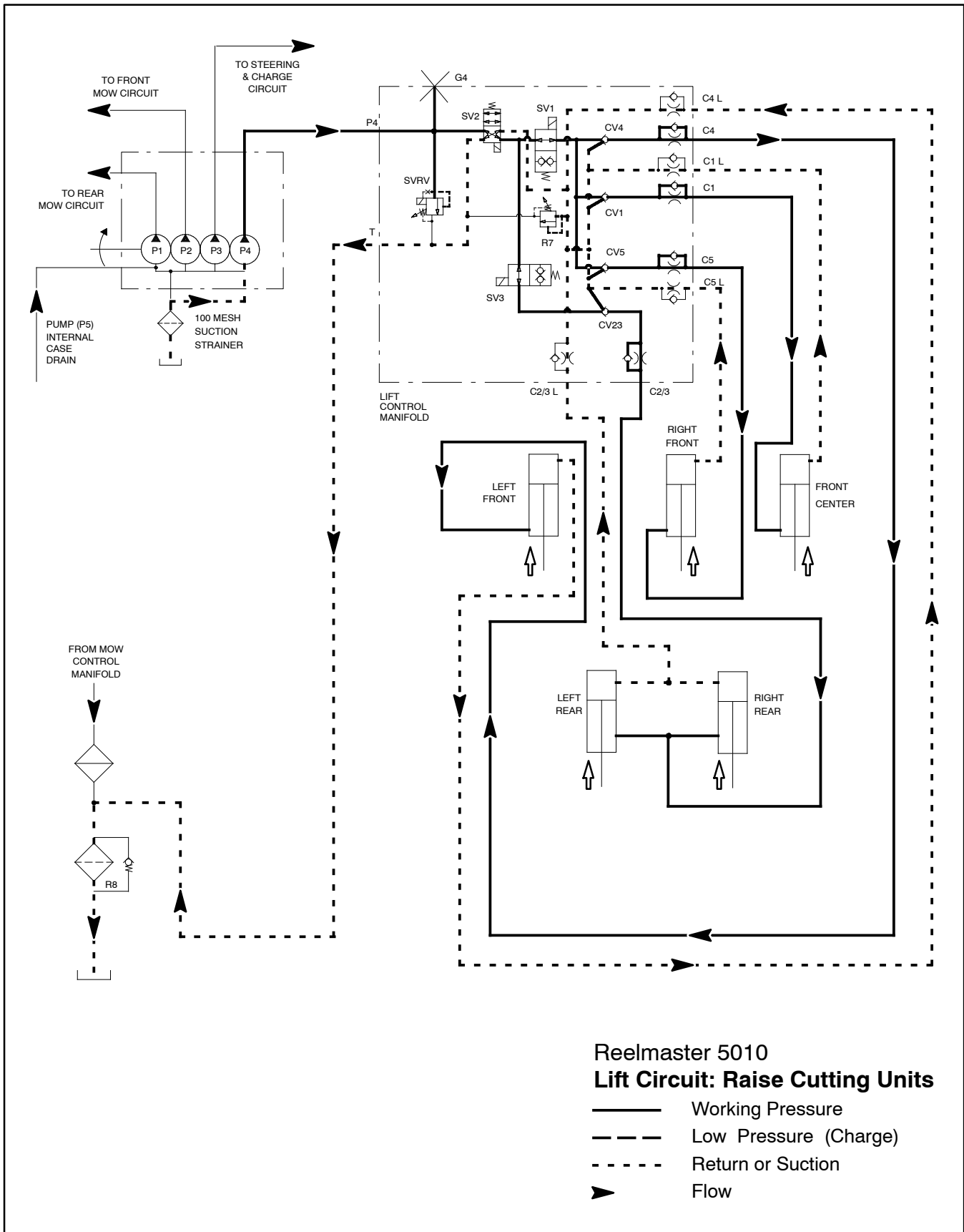

Figure 11

Lift Circuit: Raise Cutting Units

A four section gear pump is coupled to the piston (traction) pump. Gear pump section (P4) supplies hydraulic flow to the lift control manifold and ultimately for the lift cylinders. The gear pump takes its suction from the hydraulic reservoir. Lift circuit pressure is limited to 2000 PSI (138 bar) by a solenoid relief valve (SVRV) located in the lift control manifold.

The lift control manifold includes four (4) electrically operated solenoid valves. Valve (SVRV) is used to direct gear pump flow to the lift cylinders when energized or bypass pump flow back to the reservoir when de-energized. Valve (SV2) is used to direct oil flow to retract the lift cylinders when energized or extend them when de-energized. Valve (SV1) allows hydraulic flow to the front lift cylinders when energized. Valve (SV3) allows hydraulic flow to the rear lift cylinders when energized.

Lift circuit pressure can be monitored at lift control manifold port G4.

The Electronic Control Module (ECM) uses inputs from various machine switches to determine when lift manifold solenoid valves (SV1, SV2, SV3 and SVRV) are to be energized. The ECM also provides a partial raise position of the front outside cutting units.

During conditions of not raising or lowering the cutting units (joystick in the neutral (center) position), all four (4) lift manifold solenoid valves (SV1, SV2, SV3 and SVRV) are de-energized. Hydraulic flow from gear pump section (P4) by-passes the lift cylinders to the oil cooler and then to the hydraulic reservoir.

Raise Cutting Units (Fig. 11)

When the joystick is moved to the raise position, solenoid valve (SVRV) energizes along with solenoid valves (SV1), (SV2) and (SV3). The energized solenoid valves direct gear pump section P4 oil flow to the rod end of the lift cylinders. Hydraulic pressure against the rod side of the cylinders causes the shafts to retract, and raises the cutting units. Fixed orifices in the lift control manifold (C1L, C4L, C5L and C23L) control the lifting speed by providing a restriction for the return flow from the lift cylinders.

When the joystick is returned to the neutral (center) position, the solenoid valves are de-energized and the lift cylinders (and cutting units) are held in the raised position. Piloted check valves in the lift control manifold (CV1, CV4, CV5 and CV23) prevent the lift cylinders (and cutting units) from dropping after they have been raised.

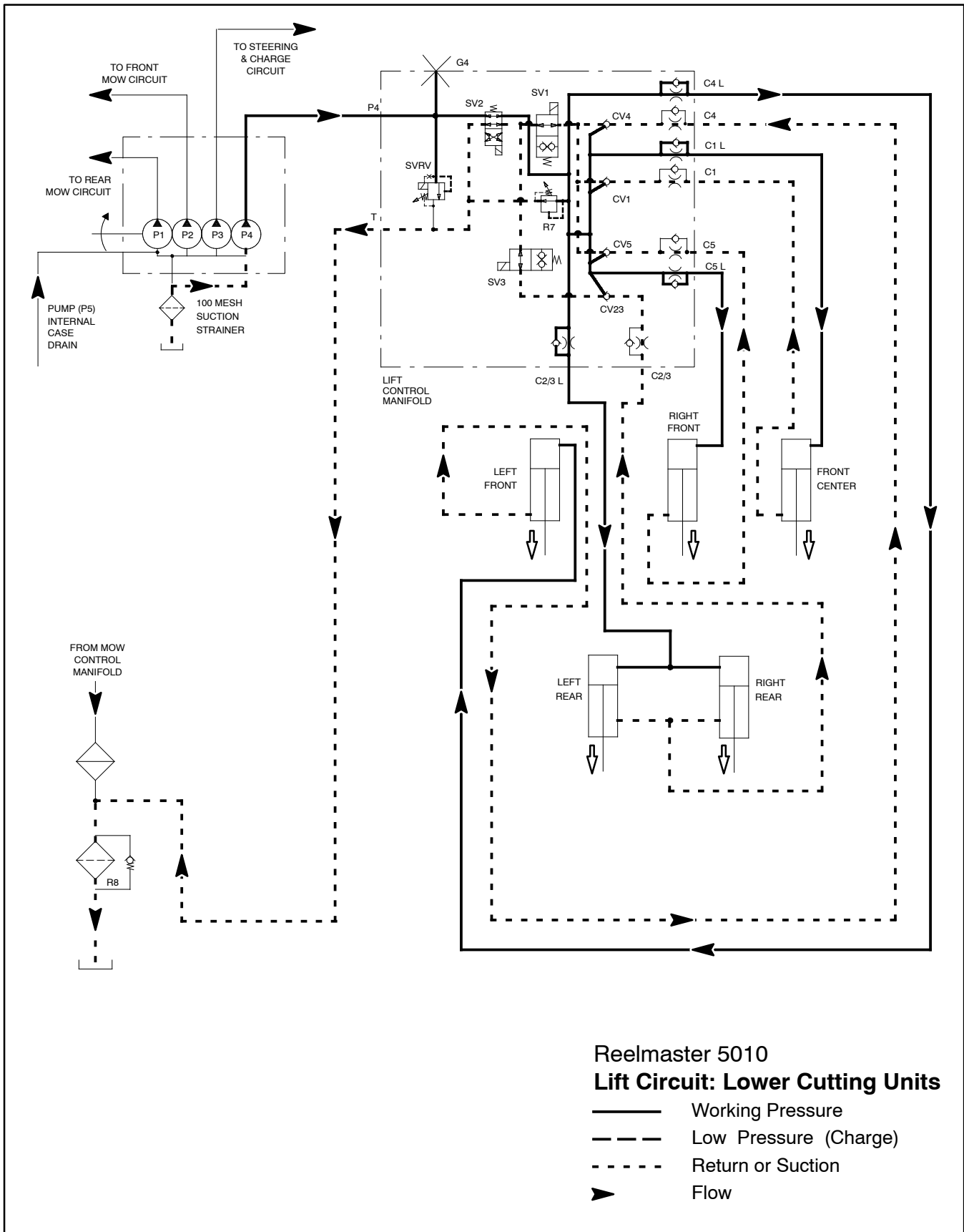

Figure 12

Lift Circuit: Lower Cutting Units

A four section gear pump is coupled to the piston (traction) pump. Gear pump section (P4) supplies hydraulic flow to the lift control manifold and ultimately for the lift cylinders. The gear pump takes its suction from the hydraulic reservoir. Lift circuit pressure is limited to 2000 PSI (138 bar) by a solenoid relief valve (SVRV) located in the lift control manifold.

The lift control manifold includes four (4) electrically operated solenoid valves. Valve (SVRV) is used to direct gear pump flow to the lift cylinders when energized or bypass pump flow back to the reservoir when de-energized. Valve (SV2) is used to direct oil flow to retract the lift cylinders when energized or extend them when de-energized. Valve (SV1) allows hydraulic flow to the front lift cylinders when energized. Valve (SV3) allows hydraulic flow to the rear lift cylinders when energized.

Lift circuit pressure can be monitored at lift control manifold port G4.

The Electronic Control Module (ECM) uses inputs from various machine switches to determine when lift manifold solenoid valves (SV1, SV2, SV3 and SVRV) are to be energized. The ECM also provides a partial raise position of the front outside cutting units.

During conditions of not raising or lowering the cutting units (joystick in the neutral (center) position), all four (4) lift manifold solenoid valves (SV1, SV2, SV3 and SVRV) are de-energized. Hydraulic flow from gear pump section (P4) by-passes the lift cylinders to the oil cooler and then to the hydraulic reservoir.

Lower Cutting Units (Fig. 12)

When the joystick is moved to the lower position, solenoid valve (SVRV) energizes along with solenoid valves (SV1) and (SV3). Solenoid valve (SV2) is in its normally de-energized position, and directs oil flow to the piston end of the lift cylinders. Hydraulic pressure against the piston side of the cylinder causes the shafts to extend, and lower the cutting units. The piloted check valves in the lift control manifold (CV1, CV4, CV5 and CV23) are shifted by hydraulic pressure to allow return flow from the extending lift cylinders. Fixed orifices in the lift control manifold (C1, C4, C5 and C23) control the lowering speed by providing a restriction for the return flow from the lift cylinders.

Because cutting unit weight assists in extending the lift cylinders when lowering the cutting units, less hydraulic pressure is necessary during the cutting unit lowering operation. Lift circuit lower relief valve (R7) allows lift circuit pressure to be limited to 500 PSI (34 bar) while lowering the cutting units.

NOTE: Adjustment of lift circuit lower relief valve (R7) is not recommended.

When the joystick is returned to the neutral (center) position, the solenoid valves are de-energized and the lift cylinders (and cutting units) are held in the lowered position.

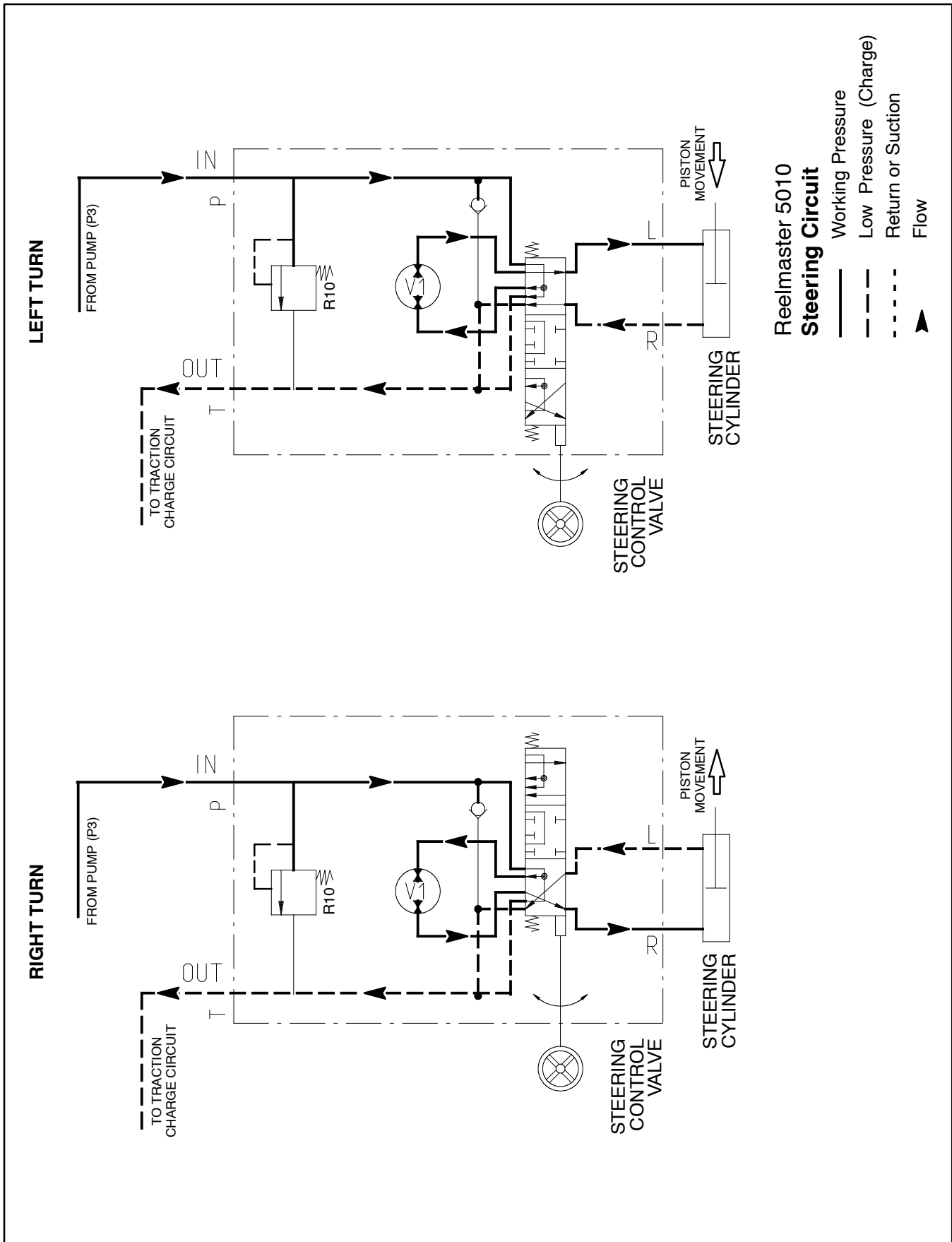

Figure 13

Steering Circuit

A four section gear pump is coupled to the piston (traction) pump. Gear pump section P3 supplies hydraulic flow to the steering control valve and for the traction charge circuit. The gear pump takes its suction from the hydraulic reservoir. Steering circuit pressure is limited to 1000 PSI (69 bar) by a relief valve (R10) located in the steering control.

With the steering wheel in the neutral position and the engine running, flow enters the steering control valve at the P port and goes through the steering control spool valve, by-passing the rotary meter (V1) and steering cylinder. Flow leaves the control valve through the T port to the transmission oil filter and traction charge circuit.

Left Turn (Fig. 13)

When a left turn is made with the engine running, the turning of the steering wheel positions the steering control spool valve so that flow is directed through the bottom of the spool. Flow entering the steering control valve at the P port goes through the spool and is routed to two places. First, most of the flow through the valve is by-passed out the T port back to the transmission oil filter and traction charge circuit. Second, the remainder of the flow is drawn through the rotary meter (V1) and out the L port. Pressure contracts the steering cylinder piston for a left turn. The rotary meter ensures that the oil flow to the steering cylinder is proportional to the amount of turning on the steering wheel. Fluid leaving the steering

cylinder flows back through the steering control spool valve and then out of the steering control valve through the T port.

The steering control valve returns to the neutral position when turning is completed.

Right Turn (Fig. 13)

When a right turn is made with the engine running, the turning of the steering wheel positions the steering control spool valve so that flow is directed through the top of the spool. Flow entering the steering control valve at the P port goes through the spool and is routed to two places. As in a left turn, most of the flow through the valve is by-passed out the T port back to the transmission oil filter and traction charge circuit. Also like a left turn, the remainder of the flow is drawn through rotary meter (V1) but goes out port R. Pressure extends the steering cylinder piston for a right turn. The rotary meter ensures that the oil flow to the steering cylinder is proportional to the amount of the turning on the steering wheel. Fluid leaving the steering cylinder flows back through the steering control spool valve then through the T port and to the hydraulic reservoir.

The steering control valve returns to the neutral position when turning is completed.

Special Tools

Order these special tools from your Toro Distributor.

Hydraulic Pressure Test Kit

Toro Part Number: **TOR47009**

Use to take various pressure readings for diagnostic tests. Quick disconnect fittings provided attach directly to mating fittings on machine test ports without tools. A high pressure hose is provided for remote readings. Contains one each: 1000 PSI (70 Bar), 5000 PSI (350 Bar) and 10000 PSI (700 Bar) gauges. Use gauges as recommended in Testing section of this chapter.



Figure 14

Hydraulic Tester (Pressure and Flow)

Toro Part Number: **TOR214678**

Use to test hydraulic circuits and components for flow and pressure capacities as recommended in the Testing section of this chapter. This tester includes the following:

1. **INLET HOSE:** Hose connected from the system circuit to the inlet side of the hydraulic tester.
2. **LOAD VALVE:** A simulated working load is created in the circuit by turning the valve to restrict flow.
3. **PRESSURE GAUGE:** Glycerine filled 0 to 5000 PSI gauge to provide operating circuit pressure.
4. **FLOW METER:** This meter measures actual oil flow in the operating circuit with a gauge rated from 1 to 15 GPM (5 to 55 LPM).
5. **OUTLET HOSE:** A hose from the outlet side of the hydraulic tester connects to the hydraulic system circuit.
6. **FITTINGS:** An assortment of hydraulic fittings are included with this kit.



Figure 15

40 GPM Hydraulic Tester (Pressure and Flow)

Toro Part Number: **AT40002**

Use to test hydraulic circuits and components for flow and pressure capacities as recommended in the Testing section of this chapter. This tester includes the following:

1. **LOAD VALVE:** A simulated working load is created in the circuit by turning the valve to restrict flow.
2. **PRESSURE GAUGE:** Glycerine filled 0 to 5000 PSI gauge to provide operating circuit pressure.
3. **FLOW METER:** This meter measures actual oil flow in the operating circuit with a gauge rated from 4 to 40 GPM (20 to 150 LPM).

NOTE: This tester does not include hoses (see Hydraulic Hose Kit TOR6007 below).



Figure 16

Hydraulic Hose Kit

Toro Part Number: **TOR6007**

This kit includes fittings and hoses needed to connect 40 GPM hydraulic tester (AT40002) or high flow hydraulic filter kit (TOR6011) to machine hydraulic traction system components.

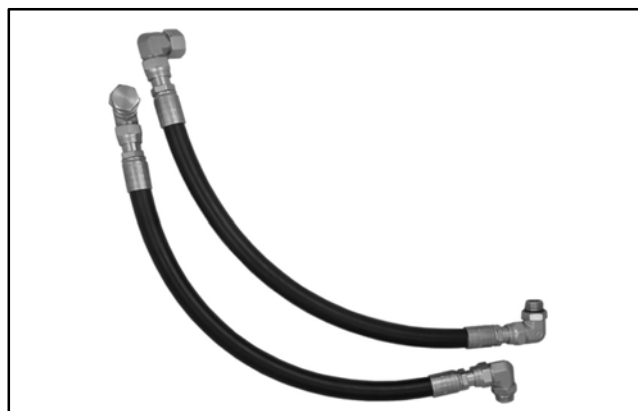

Figure 17

O-Ring Kit

Toro Part Number: **16-3799**

The kit includes O-rings in a variety of sizes for face seal and port seal hydraulic connections. It is recommended that O-rings be replaced whenever a hydraulic connection is loosened.



Figure 18

High Flow Hydraulic Filter Kit

The high flow hydraulic filter kit is designed with large flow (40 GPM/150 LPM) and high pressure (5000 PSI/345 bar) capabilities. This kit provides for bi-directional filtration which prevents filtered debris from being allowed back into the circuit regardless of flow direction.

If a component failure occurs in the closed loop traction circuit, contamination from the failed part will remain in the circuit until removed. When connecting hydraulic test gauges in order to test traction circuit components or after replacing a failed traction circuit component (e.g. hydrostat or wheel motor), the high flow hydraulic filter can be installed in the traction circuit. The filter will ensure that contaminants are removed from the closed loop and thus, do not cause additional component damage.



Figure 19

Toro Part Number: **TOR6011**

NOTE: Use of Hydraulic Hose Kit TOR6007 is recommended when using the high flow hydraulic filter kit.

NOTE: Replacement filter element is Toro part number TOR6012. Filter element cannister tightening torque is **25 ft-lb (34 N-m)**.

Hydraulic Test Fitting Kit

Toro Part Number: **TOR4079**

This kit includes a variety of O-ring face seal fittings to enable connection of test gauges to the system.

The kit includes: tee's, unions, reducers, plugs, caps and male test fittings.







TORO TEST FITTING KIT (TOR4079)			
FITTING	TOOL NUMBER	FITTING	TOOL NUMBER
	Swivel Nut Run Tee (2 ea.) Size Toro No. No. 4 TOR4079-3 No. 6 TOR4079-12 No. 8 TOR4079-4 No. 10 TOR4079-5		Union (1 ea.) Size Toro No. No. 6 to No. 8 TOR4079-8 No. 10 to No. 8 TOR4079-2 No. 8 to No. 8 TOR4079-9
	Plug (2 ea.) Toro No. No. 4 TOR4079-13 No. 6 TOR4079-14 No. 8 TOR4079-15 No. 10 TOR4079-16		Reducer (1 ea.) Size Toro No. No. 10 to No. 8 TOR4079-7 No. 12 to No. 8 TOR4079-6
	Cap (2 ea.) Toro No. No. 4 TOR4079-17 No. 6 TOR4079-18 No. 8 TOR4079-19 No. 10 TOR4079-20		Test Cap Fitting (2 ea.) Toro No. No. 4 TOR4079-10 No. 6 TOR4079-11 No. 8 TOR4079-21 No. 10 TOR4079-1
			Test Fitting (2 ea.) Size Toro No. 7/16-20 ORB TOR4079-22 1/8" Pipe Thd. TOR4079-23

Figure 20

Wheel Hub Puller

The wheel hub puller allows safe removal of the wheel hub from the wheel motor shaft.

Toro Part Number: **TOR6004**



Figure 21

Measuring Container

Part Number: **TOR4077**

Use this graduated container for doing hydraulic motor efficiency testing (motors with case drain lines only). Measure efficiency of a hydraulic motor by restricting the outlet flow from the motor and measuring leakage from the case drain line while the motor is pressurized by the hydraulic system.

The table in Figure 23 provides gallons per minute (GPM) conversion for measured milliliter or ounce leakage.



Figure 22

GPM	Milliliters in 15 sec.	Ounces in 15 sec.
.1	95	3.2
.2	189	6.4
.3	284	9.6
.4	378	12.8
.5	473	16.0
.6	568	19.2
.7	662	22.4
.8	756	25.6
.9	852	28.8
1.0	946	32.0

Figure 23

Troubleshooting

The cause of an improperly functioning hydraulic system is best diagnosed with the use of proper testing equipment and a thorough understanding of the complete hydraulic system.

A hydraulic system with an excessive increase in heat or noise has a potential for failure. Should either of these conditions be noticed, immediately stop the machine, turn off the engine, locate the cause of the trouble and correct it before allowing the machine to be used again.

Continued use of an improperly functioning hydraulic system could lead to extensive hydraulic component damage.

The charts that follow contain information to assist in troubleshooting. There may possibly be more than one cause for a machine malfunction.

Refer to the Testing section of this chapter for precautions and specific hydraulic test procedures.

General Hydraulic System Problems

Problem	Possible Cause
Hydraulic oil leaks from machine	Fitting(s), hose(s) or tube(s) is (are) loose or damaged. O-ring(s) or seal(s) is (are) missing or damaged.
Foaming hydraulic fluid	Oil level in hydraulic reservoir is low. Hydraulic system has wrong kind of oil. Pump suction line has an air leak.
Hydraulic system operates hot	Traction system pressure is high due to excessive load or brake dragging or binding. Oil level in hydraulic reservoir is low. Hydraulic oil is contaminated or too light. Engine speed is too low. Oil cooler is damaged or plugged. Air flow through oil cooler is obstructed. Oil filter is plugged. Charge pressure is low. Piston (traction) pump bypass valve is open or faulty. Piston (traction) pump check valve is not seating or is damaged. Wheel motor(s) and/or piston (traction) pump are worn or damaged (NOTE: If a traction circuit component has internal wear or damage, it is possible that other traction components are also damaged).

Traction Circuit Problems

Problem	Possible Cause
Neutral is difficult to find or unit operates in one direction only	<p>Traction control linkage is misadjusted, disconnected, binding or damaged.</p> <p>Piston (traction) pump check relief valve is not seating or is damaged (NOTE: Piston (traction) pump check relief valves for forward and reverse are identical and can be reversed for testing purposes).</p> <p>Piston (traction) pump is worn or damaged.</p>
Traction response is sluggish	<p>Charge pressure is low.</p> <p>Hydraulic oil is very cold.</p> <p>Parking brake is dragging or binding.</p> <p>Traction pump bypass valve is loosened.</p> <p>Flushing valve in traction pump is not seating or is damaged.</p> <p>Piston (traction) pump charge relief valve is not seating or is damaged.</p> <p>Piston (traction) pump check relief valve is not seating or is damaged (NOTE: Check relief valves for forward and reverse are identical and can be reversed for testing purposes).</p> <p>Piston (traction) pump is worn or damaged.</p>
No traction in either direction	<p>Parking brake is dragging or binding.</p> <p>Traction control linkage is misadjusted, disconnected, binding or damaged.</p> <p>Oil level in hydraulic reservoir is low (other hydraulic systems affected as well).</p> <p>Traction pump bypass valve is loosened.</p> <p>Flushing valve in traction pump is not seating or is damaged.</p> <p>Piston (traction) pump check valve is not seating or is damaged.</p> <p>Charge pressure is low.</p> <p>Wheel motor(s) and/or piston (traction) pump are worn or damaged (NOTE: If a traction circuit component has internal wear or damage, it is possible that other traction components are also damaged).</p>
Single wheel motor turns while unloaded, but slows down or stops when load is applied	<p>Wheel motor is worn or damaged.</p> <p>(NOTE: If a traction circuit component has internal wear or damage, it is possible that other traction components are also damaged)</p>

Traction Circuit Problems (Continued)

Problem	Possible Cause
Wheel motor will not turn	Brakes are binding. Wheel motor is worn or damaged. (NOTE: If a traction circuit component has internal wear or damage, it is possible that other traction components are also damaged)
Wheel motors will not hold load when traction pedal is in neutral	Charge pressure is low. Valve plate and/or piston shoes in piston (traction) pump are scored. (NOTE: If a traction circuit component has internal wear or damage, it is possible that other traction components are also damaged)

Mow Circuit Problems

Problem	Possible Cause
Front cutting unit motors will not operate but rear cutting unit motors will operate	Solenoid valve MSV2 on mow control manifold is faulty (NOTE: Solenoid valves MSV1 and MSV2 are similar and can be reversed for testing purposes). Mow/backlap lever for front cutting units (MR2) not rotated fully. An electrical problem exists that prevents MSV2 solenoid coil on mow control manifold from being energized (see Troubleshooting in Chapter 5 - Electrical System). Front cutting reel(s) is binding. Gear pump section (P2) is worn or damaged.
Rear cutting unit motors will not operate but front cutting unit motors will operate	Solenoid valve MSV1 on mow control manifold is faulty (NOTE: Solenoid valves MSV1 and MSV2 are similar and can be reversed for testing purposes). Mow/backlap lever for rear cutting units (MR1) not rotated fully. An electrical problem exists that prevents MSV1 solenoid coil on mow control manifold from being energized (see Troubleshooting in Chapter 5 - Electrical System). Rear cutting reel(s) is binding. Gear pump section (P1) is worn or damaged.
Single cutting unit motor will not operate or rotates slowly	Cutting unit motor is worn or damaged. Cross-over relief valve in cutting unit motor is stuck or faulty (Reelmaster 5510 and 5610 machines).

Lift Circuit Problems

Problem	Possible Cause
Single cutting unit lifts slowly or not at all	<p>Cutting unit has excessive debris buildup.</p> <p>Lift arm or lift cylinder is binding.</p> <p>Pilot piston in lift control manifold is stuck or damaged.</p> <p>Lift cylinder leaks internally.</p> <p>Flow control orifice in lift control manifold for the affected cutting unit is plugged or damaged.</p>
Cutting units raise, but will not remain in the raised position (NOTE: Lift cylinders and control manifold check valves cannot provide an absolutely perfect seal. The cutting units will eventually lower if left in the raised position)	<p>Lift cylinder leaks internally.</p> <p>Check valve in lift control manifold (CV1, CV4, CV5 and CV23) and solenoid valve (SV1 and SV3) leaks.</p> <p>Pilot piston in lift control manifold is stuck and is preventing check valve from seating.</p>
None of the cutting units will raise or lower	<p>Oil level in hydraulic reservoir is low (other hydraulic systems affected as well).</p> <p>MR1 and/or MR2 in lift control manifold are in the backlap position.</p> <p>Solenoid valve SVRV on lift control manifold is faulty.</p> <p>An electrical problem exists that prevents SVRV solenoid coil on the lift control manifold from being energized (see Troubleshooting in Chapter 5 - Electrical System).</p> <p>Gear pump section (P4) is worn or damaged.</p>
None of the front cutting units will raise or lower but the rear cutting units will raise and lower	<p>Solenoid valve SV1 on lift control manifold is faulty.</p> <p>An electrical problem exists that prevents SV1 solenoid coil on the lift control manifold from being energized (see Troubleshooting in Chapter 5 - Electrical System).</p>
Neither of the rear cutting units will raise or lower but the front cutting units will raise and lower	<p>Solenoid valve SV3 on lift control manifold is faulty.</p> <p>An electrical problem exists that prevents SV3 solenoid coil on the lift control manifold from being energized (see Troubleshooting in Chapter 5 - Electrical System).</p> <p>Flow control orifice in lift control manifold for the rear cutting units (C23 or C23L) is plugged or damaged.</p> <p>Check valve in lift control manifold for the rear cutting units (CV23) is stuck or damaged.</p>

Lift Circuit Problems (Continued)

Problem	Possible Cause
Single cutting unit lowers very slowly or not at all	Lift arm or lift cylinder is binding. Lift cylinder is damaged. Flow control orifice in lift control manifold for the affected cutting unit is plugged or damaged. Check valve in lift control manifold (CV1, CV4, CV5 and CV23) is stuck or damaged.

Steering Circuit Problems

Problem	Possible Cause
Steering inoperative or sluggish	Steering components (e.g. tie rods, steering cylinder ends) are worn or binding. Steering cylinder is binding. Oil level in hydraulic reservoir is low (other hydraulic systems affected as well). Steering relief valve (R12) in steering control valve is stuck or damaged. Steering cylinder leaks internally. Steering control valve is worn or damaged. Gear pump section (P3) is worn or damaged (NOTE: A worn or damaged gear pump section (P3) will also affect the traction (charge) circuit).

This page is intentionally blank.

Testing

The most effective method for isolating problems in the hydraulic system is by using hydraulic test equipment such as pressure gauges and flow meters in the circuits during various operational checks (see the Special Tools section in this chapter).

Before Performing Hydraulic Tests

IMPORTANT: All obvious areas such as oil supply, oil filter, binding linkages, loose fasteners or improper adjustments must be checked before assuming that a hydraulic component is the source of a hydraulic system problem.

Precautions for Hydraulic Testing

	CAUTION
<p>Failure to use gauges with expected pressure (psi) rating as listed in test procedures could result in damage to the gauge and possible personal injury from leaking hot oil.</p>	

	CAUTION
<p>All testing should be performed by two (2) people. One person should be in the seat to operate the machine and the other should read and record test results.</p>	

	WARNING
<p>Keep body and hands away from pin hole leaks or nozzles that eject hydraulic fluid under high pressure. Do not use hands to search for leaks; use paper or cardboard. Hydraulic fluid escaping under pressure can have sufficient force to penetrate the skin and cause serious injury. If fluid is injected into the skin, it must be surgically removed within a few hours by a doctor familiar with this type of injury. Gangrene may result from such an injury.</p>	

1. Clean machine thoroughly before disconnecting or disassembling any hydraulic components. Always keep in mind the need for cleanliness when working on hydraulic equipment. Contamination can cause excessive wear or binding of hydraulic components.

2. Review all test steps before starting the test procedure.

3. Before testing, check all control linkages for improper adjustment, binding or broken parts.

4. All hydraulic tests should be made with the hydraulic oil at normal operating temperature. Operate the machine under load for at least ten (10) minutes before performing hydraulic tests.

	WARNING
<p>Before disconnecting or performing any work on the hydraulic system, all pressure in the system must be relieved. See Relieving Hydraulic System Pressure in the General Information section.</p>	

5. Put metal caps or plugs on any hydraulic lines left open or exposed during testing or component removal.

6. When using hydraulic tester (pressure and flow), the inlet and the outlet hoses must be properly connected and not reversed to prevent damage to the hydraulic tester or components.

7. Install hydraulic fittings finger tight and far enough to make sure that they are not cross-threaded before tightening them with a wrench.

8. Position tester hoses to prevent rotating machine parts from contacting and damaging the hoses or tester.

9. After connecting test equipment, check oil level in the hydraulic tank to make sure that oil level is correct.

10. When using hydraulic tester (pressure and flow), open tester load valve completely before starting engine to minimize the possibility of damaging components.

11. The engine must be in good operating condition. Use a phototac when performing a hydraulic test. Engine speed can affect the accuracy of the tester readings. Check actual speed of the pump when performing hydraulic flow tests.

12. After hydraulic test procedures have been completed, check oil level in the hydraulic tank to make sure that oil level is correct.

Which Hydraulic Tests Are Necessary?

Before beginning any hydraulic test, identify if the problem is related to the traction circuit, cutting (mow) circuit, lift circuit or steering circuit. Once the faulty system has been identified, perform tests that relate to that circuit.

1. If a traction circuit problem exists, consider performing one or more of the following tests: Traction Circuit Relief Pressure, Traction Circuit Charge Pressure, Gear Pump (P3) Flow, Wheel Motor Efficiency and/or Piston (Traction) Pump Flow Tests.

2. If a cutting (mow) circuit problem exists, consider performing one or more of the following tests: Relief Valve (R1) and (R2) Pressure, Gear Pump (P1) and (P2) Flow, Reel Drive Motor Efficiency and/or Reel Drive Motor Cross-Over Relief Pressure (Reelmaster 5510 and 5610) Tests.

3. If a lift circuit problem exists, consider performing one or more of the following tests: Lift Relief Valve (R6) Pressure, Gear Pump (P4) Flow and/or Lift Cylinder Internal Leakage Tests.

4. If a steering circuit problem exists, consider performing one or more of the following tests: Steering Relief Valve (R10) Pressure, Steering Cylinder Internal Leakage and/or Gear Pump (P3) Flow Tests.

Traction Circuit Relief Valve (R3) and (R4) Pressure Test

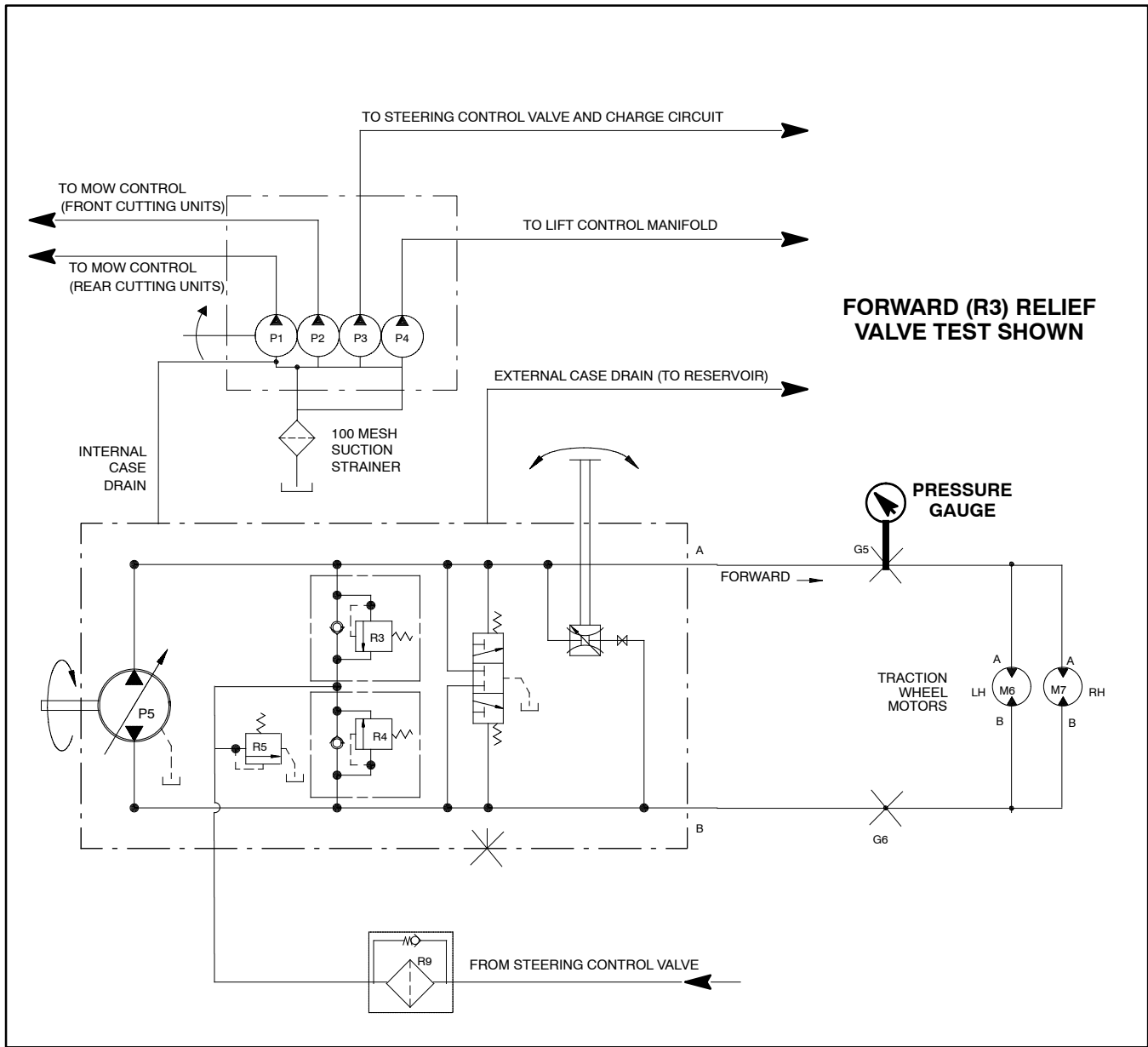

Figure 24

The traction circuit relief pressure test should be performed to make sure that forward and reverse traction circuit relief pressures are correct.

Procedure for Traction Circuit Relief Valve (R3) and (R4) Pressure Test

1. Make sure hydraulic oil is at normal operating temperature by operating the machine under load for approximately ten (10) minutes.

2. Drive machine to an open area. Park machine on a level surface with the cutting units lowered and PTO switch off. Make sure engine is off. Apply the parking brake.

3. Read Precautions For Hydraulic Testing in this section.



CAUTION

Before opening hydraulic system, operate all hydraulic controls to relieve system pressure and avoid injury from pressurized hydraulic oil. See Relieving Hydraulic System Pressure in the General Information section of this chapter.

NOTE: If machine is equipped with optional CrossTrax™ AWD, reverse relief pressure test ports are located on CrossTrax™ hydraulic manifold.

4. Thoroughly clean traction circuit test port on hydraulic tube for direction to be checked (Fig. 25 and 26). Connect a 5000 PSI (350 bar) pressure gauge to test port.
5. After installing tester, start engine and run at idle speed. Check for any hydraulic leakage from test connections and correct before proceeding with test.
6. Move throttle to full speed (**3200 RPM**).
7. Sit on seat, and with brakes applied, slowly depress the traction pedal in the direction to be tested (forward or reverse). While pushing traction pedal down, carefully watch the pressure gauge needle. As the traction relief valve lifts, the gauge needle will momentarily stop. Traction system pressure as the relief valve opens should be:

Approximately 3825 PSI (264 bar) in both forward (R3) and reverse (R4)

NOTE: If traction pedal continues to be pressed after the relief valve has opened, system pressure can increase higher than relief pressure.

8. Release traction pedal, stop engine and record test results.

NOTE: Forward (R3) and reverse (R4) relief valves are identical. Relief valves can be switched in traction pump to help in identifying a faulty relief valve.

9. If problem occurs in one direction only, interchange the relief valves in the traction pump (Fig. 27) to see if the problem changes to the other direction. Clean or replace valves as necessary. These cartridge type valves are factory set, and are not adjustable. If relief valves are in good condition, traction pump and/or wheel motors should be suspected of wear and inefficiency.

10. After testing is completed, make sure that engine is stopped and then relieve hydraulic system pressure (See Relieving Hydraulic System Pressure in the General Information section of this chapter). Remove pressure gauge from machine.

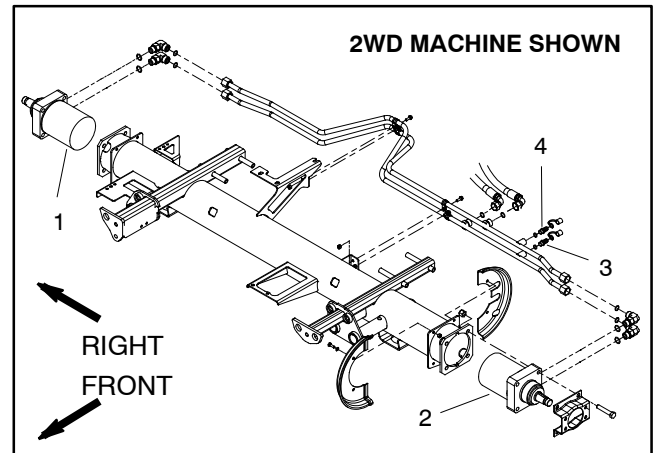

Figure 25

- | | |
|-------------------|----------------------|
| 1. RH wheel motor | 3. Forward test port |
| 2. LH wheel motor | 4. Reverse test port |

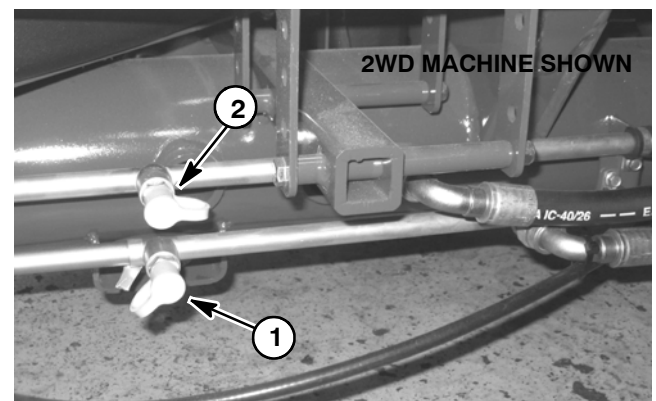

Figure 26

- | | |
|----------------------|----------------------|
| 1. Forward test port | 2. Reverse test port |
|----------------------|----------------------|

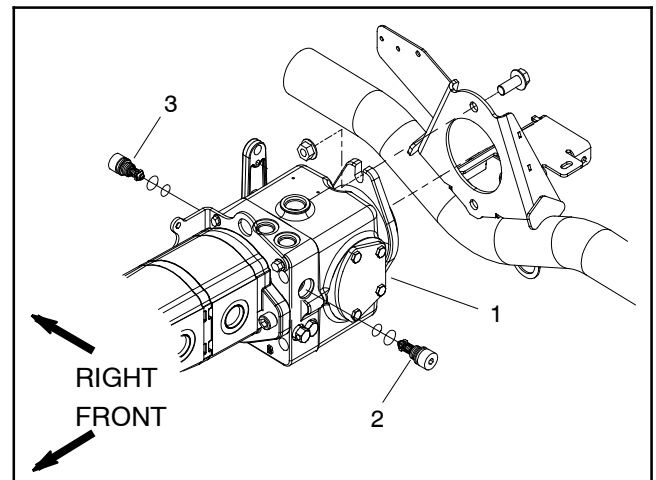

Figure 27

- | | |
|------------------------------|------------------------------|
| 1. Piston (traction) pump | 3. Forward relief valve (R3) |
| 2. Reverse relief valve (R4) | |

Traction Circuit Charge Pressure Test

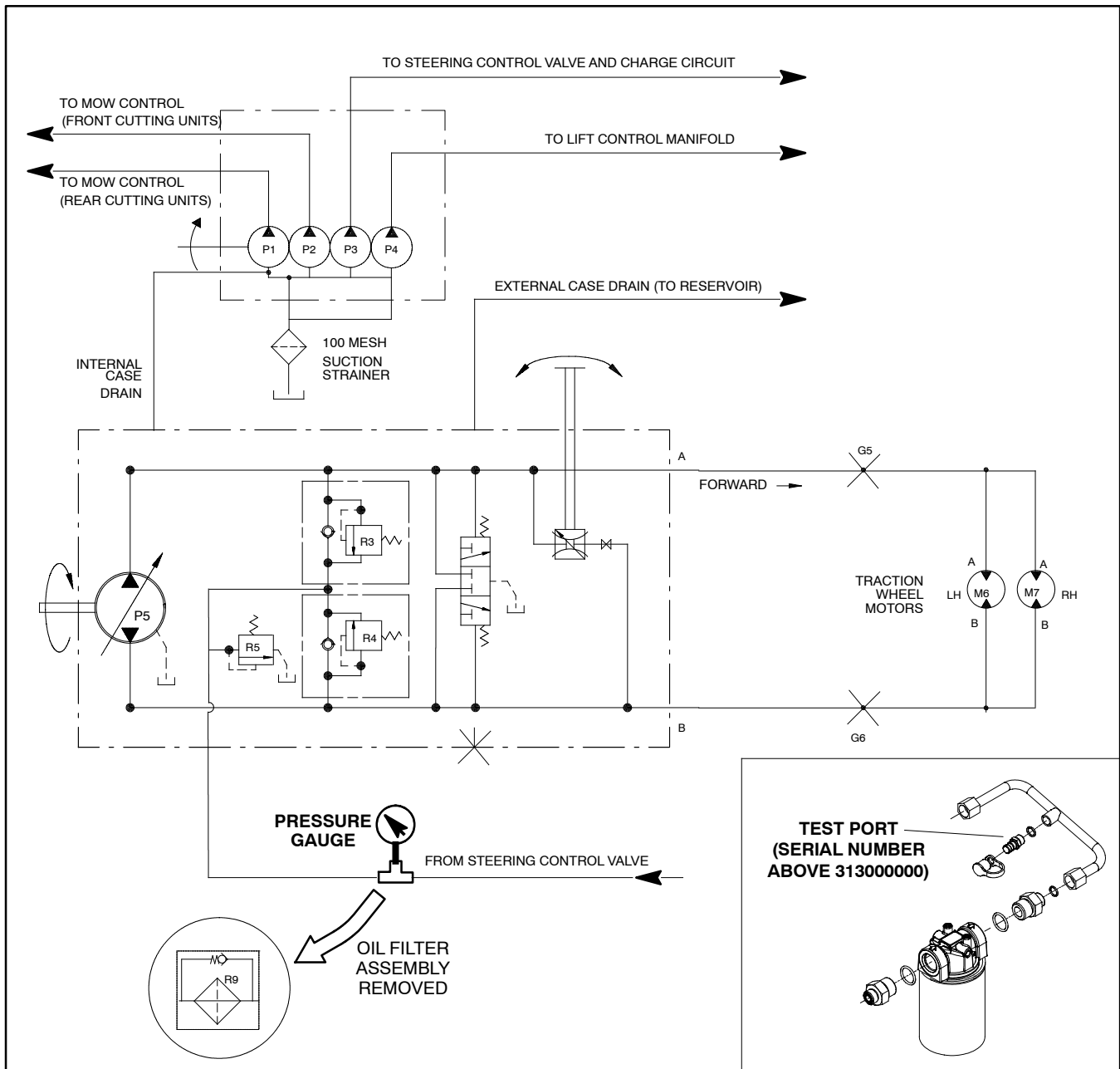

Figure 28

The traction circuit charge pressure test should be performed to make sure that the traction charge circuit is functioning correctly.

Procedure for Traction Circuit Charge Pressure Test

1. Make sure hydraulic oil is at normal operating temperature by operating the machine under load for approximately ten (10) minutes.
2. Park machine on a level surface with the cutting units lowered and PTO switch off. Make sure engine is off. Apply the parking brake. Raise and support operator seat.

3. Read Precautions For Hydraulic Testing in this section.



CAUTION

Before opening hydraulic system, operate all hydraulic controls to relieve system pressure and avoid injury from pressurized hydraulic oil. See Relieving Hydraulic System Pressure in the General Information section of this chapter.

4. Connect a 1000 PSI (70 bar) pressure gauge to machine:

A. On machine with serial number below 313000000, thoroughly clean ends of hydraulic tubes that connect to the oil filter (there is no test port in hydraulic tube between the oil filter and piston pump on these machines as shown in Fig. 29). Disconnect hydraulic tubes from oil filter adapter. Remove two (2) flange head screws that secure oil filter adapter to frame and remove oil filter and adapter assembly from machine. Install tee fitting with 1000 PSI (70 bar) pressure gauge in place of the removed hydraulic filter assembly.

B. On machine with serial number above 313000000, thoroughly clean test port on hydraulic tube between piston (traction) pump and oil filter (shown in Fig. 28). Connect a 1000 PSI (70 bar) pressure gauge to test port.

5. Make sure that traction pedal is in neutral, the steering wheel is stationary and parking brake is engaged.

6. Start engine and run at idle speed. Check for any hydraulic leakage from test connections and correct before proceeding with test.

7. Place throttle to full speed (**3200 RPM**) and monitor pressure gauge on tester to determine no load charge pressure. Record test results.

GAUGE READING TO BE approximately 200 to 250 PSI (13.8 to 17.2 bar)

8. Next, determine charge pressure under traction load by operating the machine in a direct forward and reverse direction (not steering). Make sure that engine is running at full speed (**3200 RPM**). Apply the brakes and press the traction pedal in the forward direction and then to reverse while monitoring the pressure gauge. Stop engine and record test results.

GAUGE READING TO BE approximately 150 to 250 PSI (13.8 to 17.2 bar)

9. Compare measured charge pressure from step 7 with pressure from step 8:

A. If charge pressure is good under no load (step 7), but drops below specification when under traction load (step 8), the piston pump should be suspected of wear and inefficiency. When the pump is worn or damaged, the charge system is not able to replenish lost traction circuit oil due to excessive leakage in the worn pump.

B. If there is no charge pressure, or pressure is low, check for restriction in gear pump intake line. Inspect charge relief valve and valve seat in the traction pump (see Traction Pump Service in the Service and Repairs section of this chapter). Also, consider a worn or damaged gear pump (P3) (see Gear Pump (P3) Flow Test in this section).

NOTE: If gear pump (P3) is worn or damaged, both charge circuit and steering circuit will be affected.

10. After charge pressure testing is completed, make sure that engine is not running and then relieve hydraulic system pressure (See Relieving Hydraulic System Pressure in the General Information section of this chapter). Remove pressure gauge. Install oil filter assembly to machine if it was removed.

11. Lower and secure operator seat.

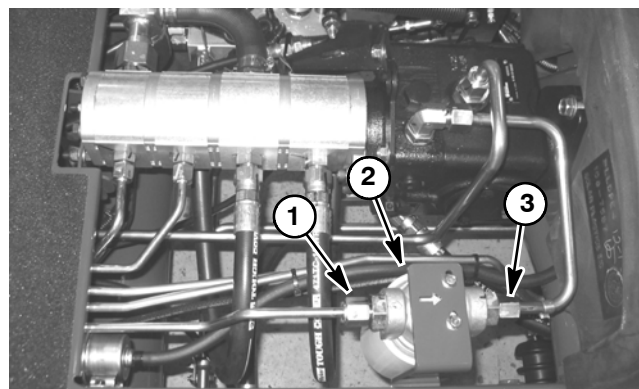

Figure 29

- 1. Hydraulic tube
- 2. Oil filter / filter adapter
- 3. Hydraulic tube

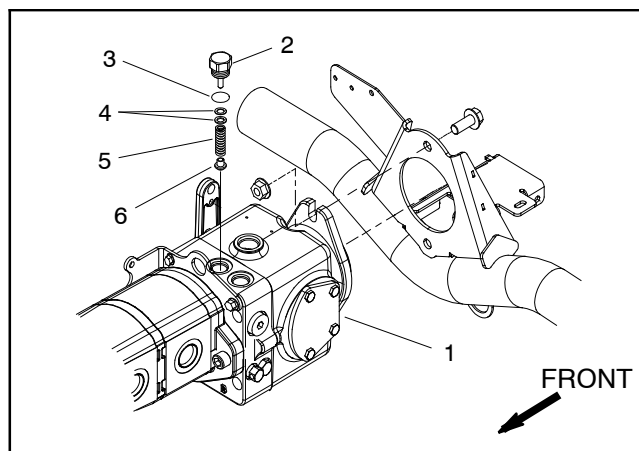

Figure 30

- 1. Traction pump
- 2. Plug
- 3. O-ring
- 4. Shim kit
- 5. Spring
- 6. Charge relief poppet

Gear Pump (P3) Flow Test (Using Tester with Pressure Gauges and Flow Meter)

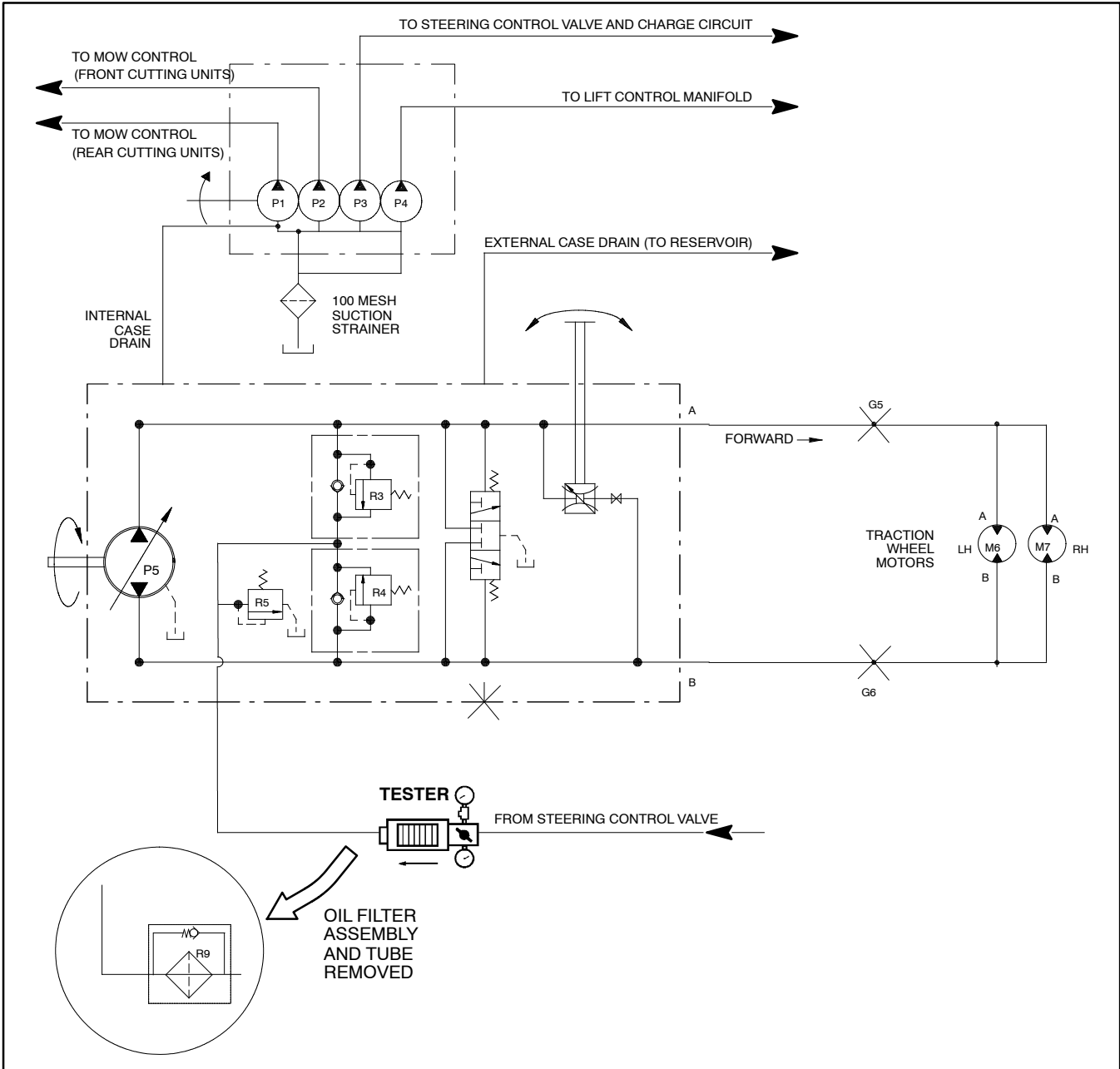

Figure 31

The gear pump (P3) flow test should be performed to make sure that the traction charge circuit and steering circuit have adequate hydraulic flow.

Procedure for Gear Pump (P3) Flow Test

1. Make sure hydraulic oil is at normal operating temperature by operating the machine under load for approximately ten (10) minutes.
2. Park machine on a level surface with the cutting units lowered and PTO switch off. Make sure engine is off. Apply the parking brake.
3. Read Precautions For Hydraulic Testing in this section.

**CAUTION**

Before opening hydraulic system, operate all hydraulic controls to relieve system pressure and avoid injury from pressurized hydraulic oil. See Relieving Hydraulic System Pressure in the General Information section of this chapter.

4. Raise and prop operator seat to allow access to hydraulic pump.
5. Thoroughly clean the ends of the hydraulic tubes connected to the oil filter and traction pump inlets (Fig. 32). Disconnect hydraulic tubes from oil filter inlet and traction pump inlet. Remove two (2) flange head screws that secure oil filter adapter to frame. Remove oil filter assembly and hydraulic tube from machine.

IMPORTANT: Make sure that the oil flow indicator arrow on the flow meter is showing that the oil will flow from the hydraulic tube, through the tester and into the traction pump.

6. Install tester with pressure gauges and flow meter in place of the removed oil filter assembly and hydraulic tube. Connect tester inlet hose to the hydraulic tube. Connect the tester outlet hose to the traction pump fitting. **Make sure the flow control valve on tester is fully open.**
7. Make sure that the traction pedal is in neutral, the steering wheel is stationary and the parking brake is engaged.
8. Start engine and run at idle speed. Check for any hydraulic leakage from test connections and correct before proceeding with test.

9. Move throttle to full speed (**3200 RPM**). Use a tachometer to verify that engine speed is correct.

IMPORTANT: The gear pump is a positive displacement type. If pump flow is completely restricted or stopped, damage to the pump, tester or other components could occur.

10. While watching pressure gauges, slowly close the tester flow control valve until **800 PSI (55 bar)** is obtained on gauge.

FLOW TESTER READING TO BE: A pump in good condition should have a flow of approximately **4.7 GPM (17.8 LPM)** at **800 PSI (55 bar)**.

11. Open the tester flow control valve, stop engine and record test results.

12. If flow is less than **4 GPM (15.1 LPM)** or a pressure of **800 PSI (55 bar)** cannot be obtained, consider that a pump problem exists. Check for restriction in pump intake line. If intake is not restricted, remove gear pump and repair or replace pump as necessary (see Gear Pump in the Service and Repairs section of this chapter).

NOTE: If the flow from gear pump (P3) is low, the operation of both the charge circuit and the steering circuit will be affected.

13. After testing is completed, make sure that engine is stopped, then relieve hydraulic system pressure (See Relieving Hydraulic System Pressure in the General Information section of this chapter). Connect removed hydraulic tube to oil filter and traction pump fittings.

14. Lower and secure operator seat.

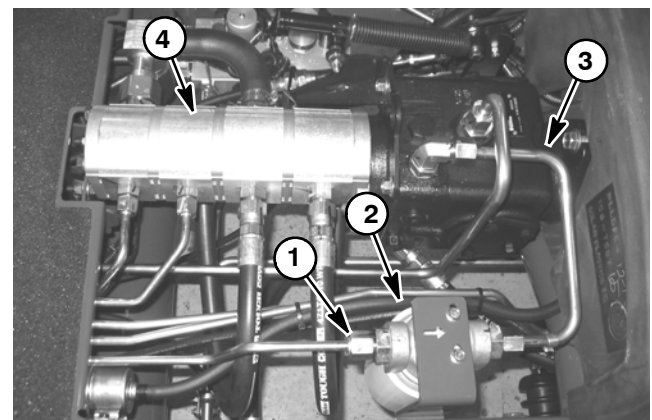

Figure 32

- | | |
|--------------------------------|-------------------|
| 1. Hydraulic tube | 3. Hydraulic tube |
| 2. Oil filter / filter adapter | 4. Gear Pump (P3) |

Front Wheel Motor Efficiency Test

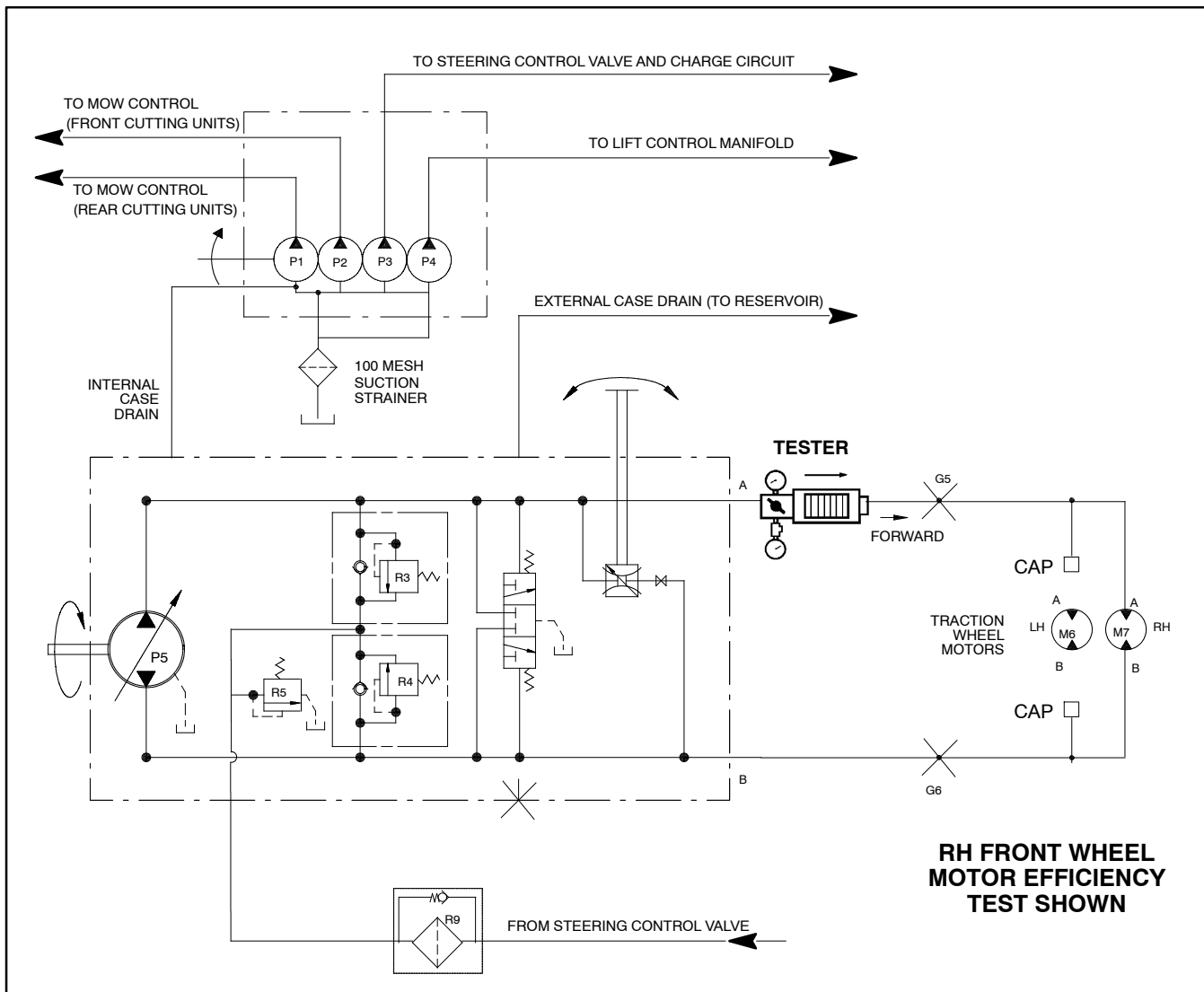

Figure 33

Procedure for Front Wheel Motor Efficiency Test

NOTE: Over a period of time, a wheel motor can wear internally. A worn motor may by-pass oil causing the motor to be less efficient. Eventually, enough oil loss will cause the wheel motor to stall under heavy load conditions. Continued operation with a worn, inefficient motor can generate excessive heat, cause damage to seals and other components in the hydraulic system and affect overall machine performance.

IMPORTANT: Refer to **Traction Circuit Component Failure in the General Information section for information regarding the importance of removing contamination from the traction circuit.**

NOTE: This test procedure includes steps to test both front wheel efficiency together before testing individual wheel motors.

1. Make sure hydraulic oil is at normal operating temperature by operating the machine under load for approximately ten (10) minutes.
2. Make sure that traction pedal is adjusted to the neutral position (see Traction Unit Operator's Manual).
3. Park machine on a level surface with the cutting units lowered and PTO switch off. Shut engine off and apply the parking brake.
4. Read Precautions For Hydraulic Testing in this section.



CAUTION

Before opening hydraulic system, operate all hydraulic controls to relieve system pressure and avoid injury from pressurized hydraulic oil. See Relieving Hydraulic System Pressure in the General Information section of this chapter.

5. Attach a heavy chain to the rear of the machine frame and an immovable object to prevent the machine from moving during testing.

6. Chock front wheels to prevent wheel rotation. Make sure parking brake is applied.

NOTE: If machine is equipped with optional CrossTrax™ AWD, jack up and support the rear wheels off the ground to allow flow through the rear wheel motors.

7. Thoroughly clean junction of hydraulic hose and **right** side elbow fitting on bottom of traction pump (Fig. 34). Disconnect hose from traction pump fitting.

IMPORTANT: Make sure that the oil flow indicator arrow on the flow meter is showing that the oil will flow from the pump, through the tester and into the hydraulic hose.

8. Install tester with pressure gauges and flow meter in series with the traction pump and the disconnected hose. **Make sure the tester flow control valve is fully open.**

9. Start engine and move throttle to full speed (**3200 RPM**).



CAUTION

Use extreme caution when performing test. The front tires on the ground will be trying to move the machine forward.

10. Slowly push traction pedal in **forward** direction until **1000 PSI** is displayed on the tester pressure gauge.

11. Total front wheel motor internal leakage will be shown on flow meter in GPM (LPM).

12. Release traction pedal, shut engine off, rotate both front wheels and retest. Testing of wheel motor leakage in three (3) different wheel positions will provide the most accurate test results. Record measured front wheel motor internal leakage for all three (3) wheel positions.

13. If total leakage for the front wheel motors is **more than 1.5 GPM (5.7 LPM)**, one or both of the motors may be faulty. Individual front wheel motor testing is necessary.

14. To test individual front wheel motors:

A. Remove front wheel from wheel motor that is **not** being tested. Remove wheel shield to allow access to hydraulic tubes and fittings on wheel motor. Remove fasteners that secure front hydraulic tube r-clamps to frame.

B. On the front wheel motor that is **not** being tested, thoroughly clean junction of both hydraulic tubes and wheel motor fittings. Disconnect both hydraulic lines from wheel motor that is **not** being tested. Cap disconnected hydraulic lines and wheel motor fittings.

C. Use the procedure described in steps 8 to 10 above to identify individual front wheel motor leakage. Individual motor internal leakage will be shown on flow meter in GPM (LPM). Flow should be **less than 1.5 GPM (5.7 LPM)** for the tested wheel motor.

D. If other front wheel motor requires testing, complete steps A, B and C for remaining wheel motor.

15. After testing is completed, stop engine and then relieve hydraulic system pressure (See Relieving Hydraulic System Pressure in the General Information section of this chapter). Disconnect tester from hydraulic fitting and hose. Connect hose to pump elbow fitting. Remove caps from hydraulic tubes and reconnect tubes to wheel motor. Secure hydraulic tubes to machine with r-clamps and removed fasteners. Install wheel shield and wheel(s) (see Wheels in the Service and Repairs section of Chapter 6 - Chassis).

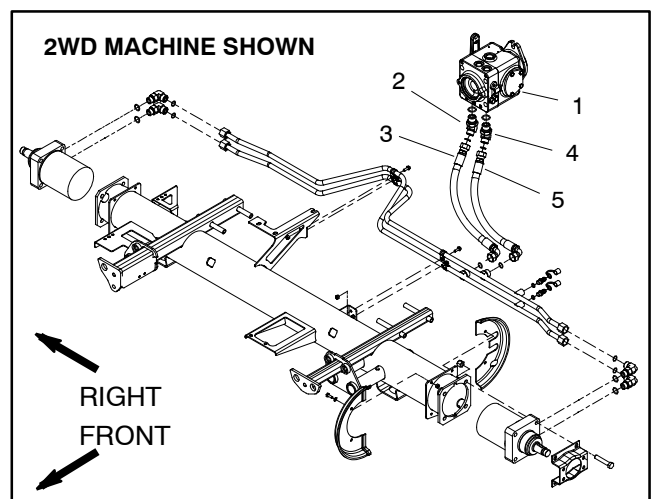

Figure 34

- | | |
|-----------------------|-----------------------|
| 1. Traction pump | 4. LH elbow fitting |
| 2. RH elbow fitting | 5. Hyd hose (reverse) |
| 3. Hyd hose (forward) | |

Piston (Traction) Pump Flow Test (Using Tester with Flow Meter and Pressure Gauge)

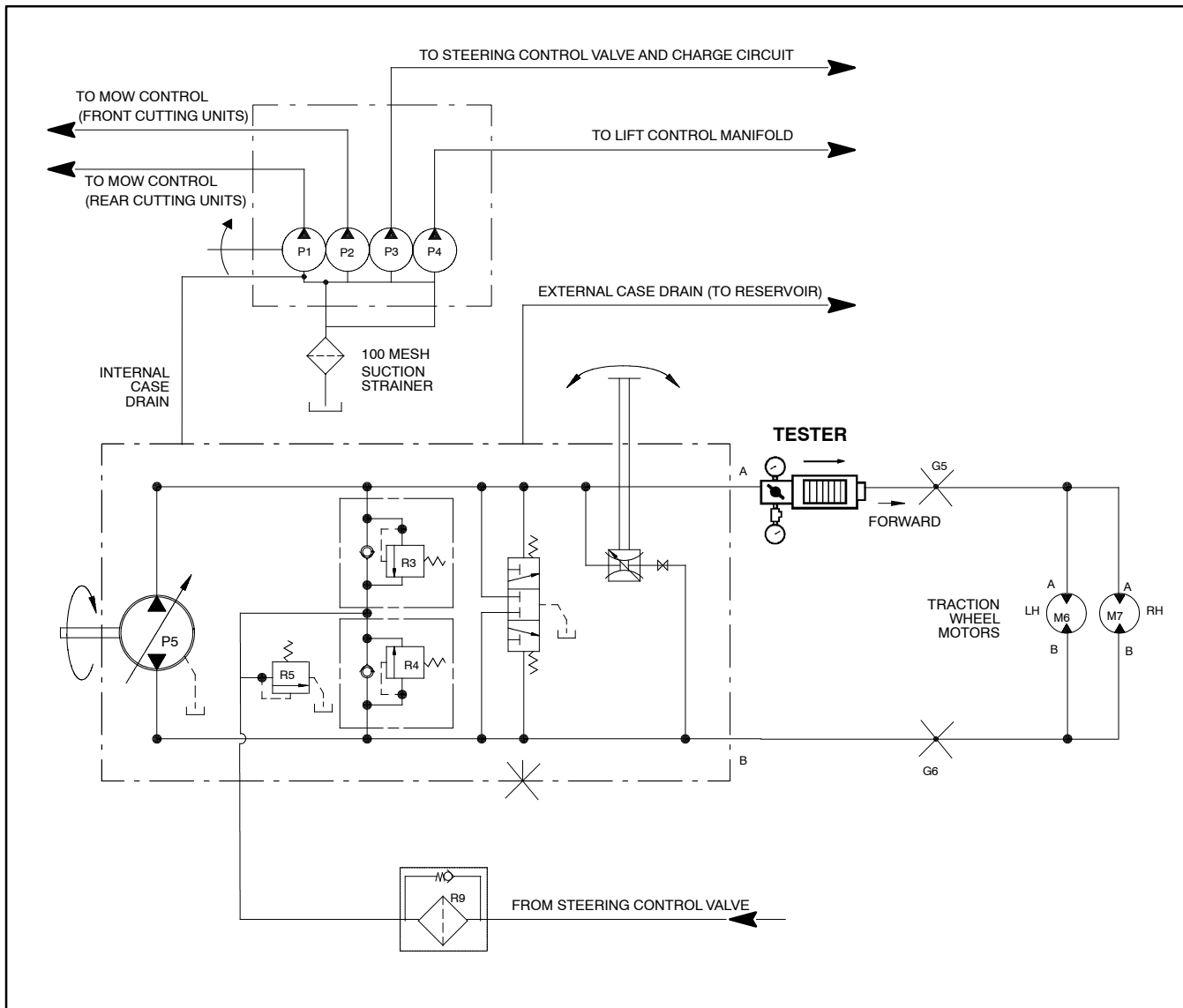

Figure 35

Procedure for Piston (Traction) Pump Flow Test

This test measures piston (traction) pump output (flow). During this test, pump load is created at the flow meter using the adjustable load valve on the tester.

IMPORTANT: Traction circuit flow for your Reelmaster is approximately 30 GPM (113.5 LPM). Use 40 GPM Hydraulic Tester #AT40002 (pressure and flow) for this test (see Special Tools in this chapter).

1. Make sure hydraulic oil is at normal operating temperature by operating the machine under load for approximately ten (10) minutes. Make sure the hydraulic tank is full.

2. Park machine on a level surface with the cutting units lowered and off. Shut off engine. Make sure mow speed limiter is in the transport position to allow full movement of traction pedal.

3. Read Precautions For Hydraulic Testing in this section.



CAUTION

Before opening hydraulic system, operate all hydraulic controls to relieve system pressure and avoid injury from pressurized hydraulic oil. See Relieving Hydraulic System Pressure in the General Information section of this chapter.

4. Make sure that traction pedal is adjusted to the neutral position. Also, ensure that traction pump is at full stroke when traction pedal is pushed into fully forward position.

5. Raise and support machine so all wheels are off the ground (see Jacking Instructions in Chapter 1 - Safety).

6. Thoroughly clean junction of hydraulic hose and **right** side fitting on bottom of traction pump (Fig. 36). Disconnect hose from right side pump fitting.

IMPORTANT: Make sure that the oil flow indicator arrow on the flow meter is showing that the oil will flow from the pump, through the tester and into the disconnected hydraulic hose.

7. Install tester with pressure gauge and flow meter in series between traction pump fitting and disconnected hose to allow flow from traction pump to tester. Use hydraulic hose kit (see Special Tools in this chapter) to connect tester to machine. Make sure that fitting and hose connections are properly tightened. Also, make sure the flow control valve on tester is fully open.



CAUTION

All wheels will be off the ground and rotating during this test. Make sure machine is supported so it will not move and accidentally fall to prevent injuring anyone near the machine.

8. Start engine and run at idle speed. Check for any hydraulic leakage from tester and hose connections. Correct any leaks before proceeding.

9. Move throttle so engine is running at high idle speed (**3200 RPM**).

10. Slowly push traction pedal to fully forward position. Keep pedal fully depressed in the forward position.

11. Have second person watch pressure gauge on tester carefully while slowly closing the flow control valve until **1000 PSI (69 bar)** is obtained. Verify with a phototac that the **engine speed** is still **3200 RPM**.

12. Observe flow gauge. Flow indication should be approximately **28 GPM (106 LPM)**.

13. Release traction pedal to the neutral position, open flow control valve on tester and shut off engine. Record test results.

14. If flow is less than **25 GPM (95 LPM)**, consider the following:

A. The traction pump wash plate is not being rotated fully (e.g. traction pedal linkage may need adjustment, mow speed limiter is not in the transport position).

B. The piston (traction) pump needs to be repaired or replaced as necessary.

C. Make necessary repairs before performing additional tests.

15. When testing is complete, disconnect tester and hose kit from pump fitting and machine hydraulic hose. Reconnect hose to pump fitting.

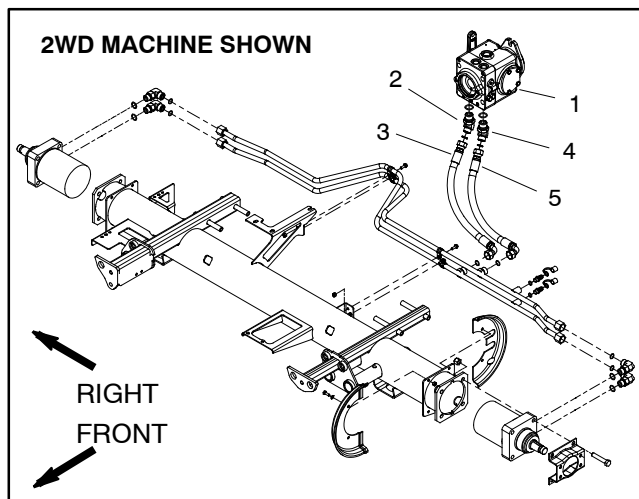

Figure 36

- | | |
|-----------------------|-----------------------|
| 1. Traction pump | 4. LH elbow fitting |
| 2. RH elbow fitting | 5. Hyd hose (reverse) |
| 3. Hyd hose (forward) | |

Relief Valve (R1) and (R2) Pressure Test

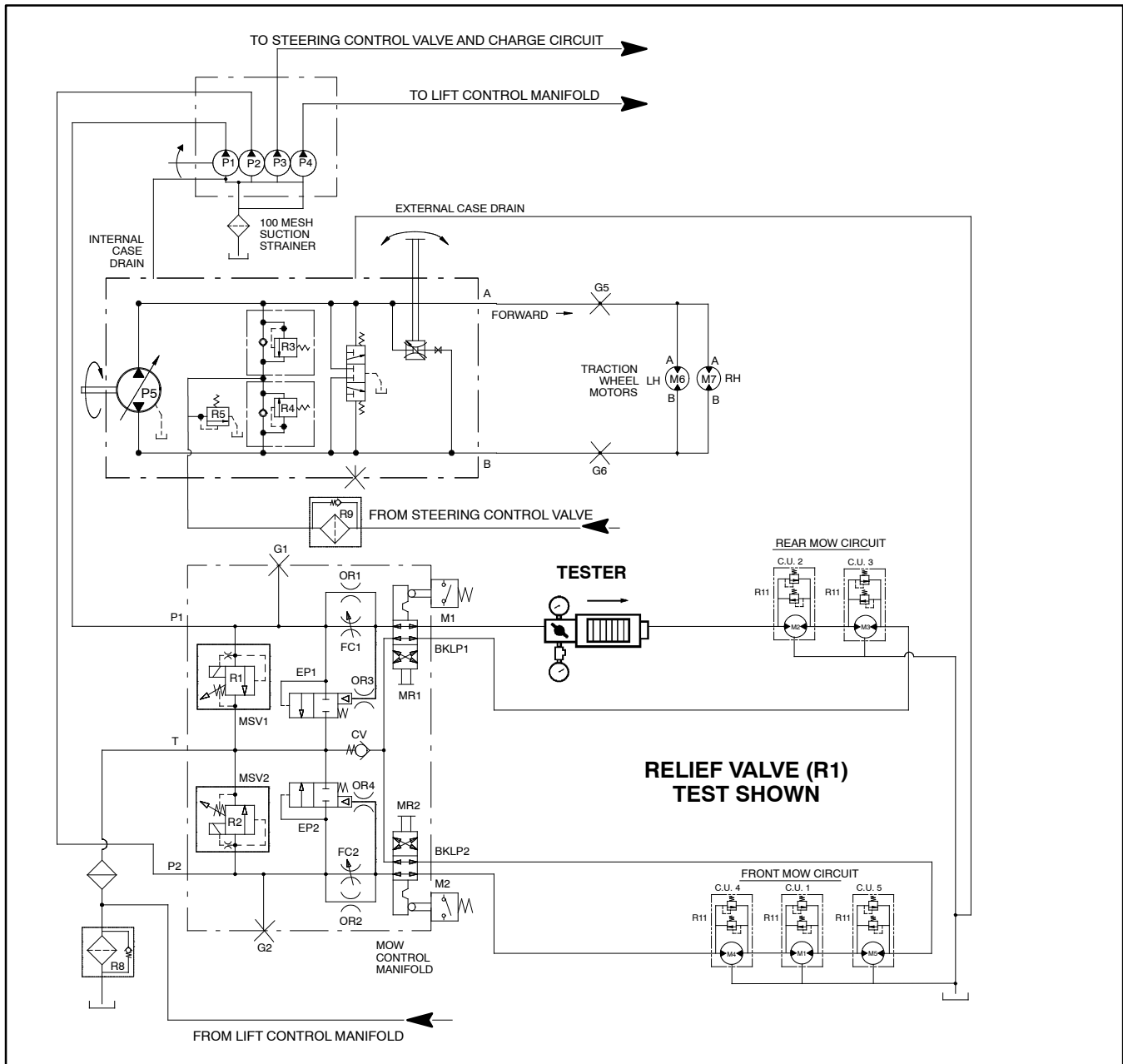

Figure 37

The relief valve (R1) and (R2) pressure test should be performed to make sure that the cutting unit circuit relief pressures are correct.

NOTE: The front cutting unit circuit is protected by relief valve (R2). The rear cutting unit circuit is protected by relief valve (R1) (see Hydraulic Flow Diagrams in this chapter).

Procedure for Relief Valve (R1) and (R2) Pressure Test

1. Make sure hydraulic oil is at normal operating temperature by operating the machine under load for approximately ten (10) minutes.
2. Park machine on a level surface with the cutting units lowered and PTO switch off. Make sure engine is off and mow/transport lever is in mow. Apply the parking brake.
3. Read Precautions For Hydraulic Testing in this section.



CAUTION

Before opening hydraulic system, operate all hydraulic controls to relieve system pressure and avoid injury from pressurized hydraulic oil. See Relieving Hydraulic System Pressure in the General Information section of this chapter.

4. Raise and prop operator seat to allow access to hydraulic mow control manifold.

5. Set reel speed controls (FC1 and FC2) to full open (highest number). Make sure backlap levers are positioned in the mow position.

6. Thoroughly clean junction of hydraulic inlet hose and reel motor fitting on left side cutting unit for the relief valve to be tested. Disconnect hose from reel motor fitting (Fig. 38):

Left rear cutting unit (#2) for relief valve (R1)

Left front cutting unit (#4) for relief valve (R2)

IMPORTANT: Make sure that the oil flow indicator arrow on the flow meter is showing that the oil will flow from the disconnected hose, through the tester and into the reel motor.

7. Install tester with pressure gauges and flow meter in series with the disconnected hose and hydraulic fitting on reel motor. **Make sure the flow control valve on tester is fully open.**

8. After installing tester, start engine and run at idle speed. Check for any hydraulic leakage from test connections and correct before proceeding with test.

9. Move throttle to full speed (**3200 RPM**).



CAUTION

Keep away from reels during test to prevent personal injury from rotating reel blades.

10. Have a second person occupy seat, press PTO switch to ON and then move Lower - Mow/Raise lever forward to engage cutting units.

IMPORTANT: When performing this test, do not hold over relief any longer than necessary to obtain pressure reading.

11. Watch pressure gauge carefully while slowly closing the tester flow control valve.

12. As the relief valve lifts, system pressure should be:

From 2450 to 2600 PSI (169 to 179 bar) for relief valve (R1)

From 3450 to 3600 PSI (238 to 248 bar) for relief valve (R2)

13. Open the tester flow control valve, disengage cutting units and stop the engine.

14. If pressure is incorrect, remove solenoid valve on mow manifold and clean or replace valve (see Mow Control Manifold Service in the Service and Repairs section of this chapter). Also, if pressure is still low after solenoid valve service, check for restriction in pump intake line. Gear pump (P2) (front cutting unit circuit) and/or pump (P1) (rear cutting unit circuit) could also be suspected of wear, damage or inefficiency (see Gear Pump (P1) and (P2) Flow Test in this section).

15. After testing is completed, make sure that engine is stopped, then relieve hydraulic system pressure (See Relieving Hydraulic System Pressure in the General Information section of this chapter). Remove tester from machine and connect hydraulic hose to reel motor fitting.

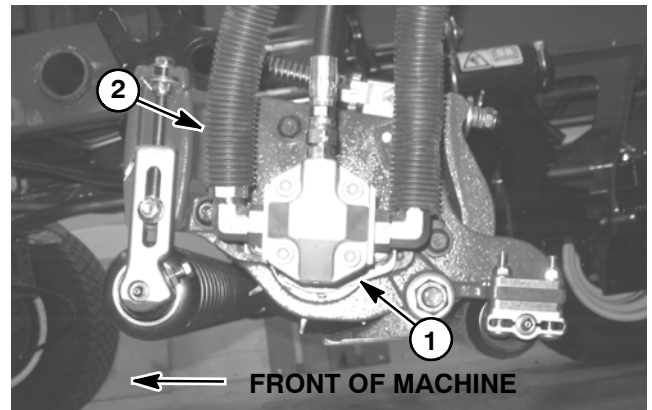

Figure 38

1. Cutting reel motor (#2 shown)
2. Reel motor inlet hose

Gear Pump (P1) and (P2) Flow Test (Using Tester with Pressure and Flow Capabilities)

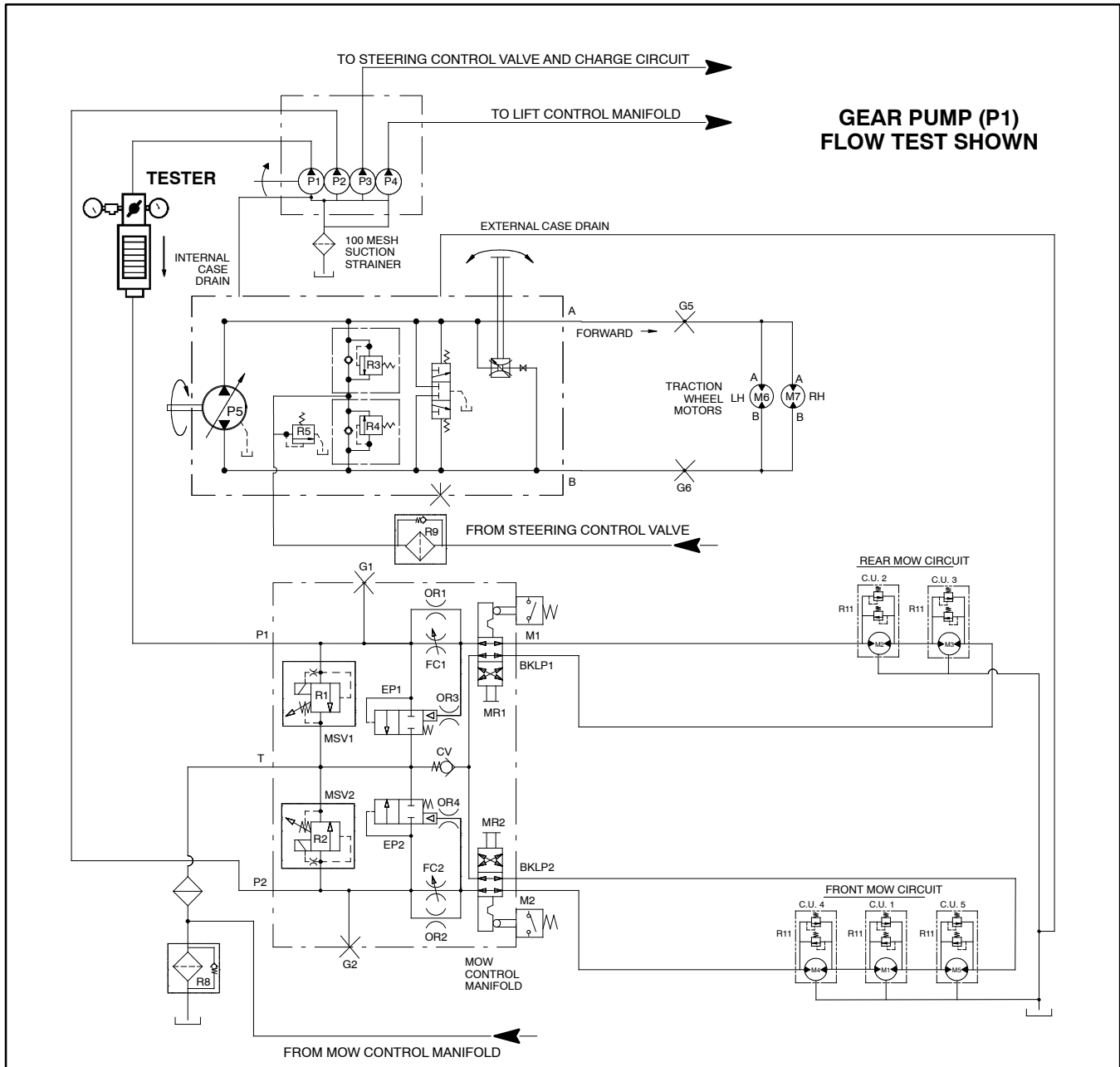

Figure 39

Over a period of time, the gears and wear plates in the gear pump can wear. A worn pump will by-pass oil and make the pump less efficient. Eventually, enough oil can by-pass to cause the reels to stall in heavy cutting conditions. Continued operation with a worn, inefficient pump can generate excessive heat and cause damage to seals and other components in the hydraulic system.

Procedure for Gear Pump (P1) and (P2) Flow Test

1. Make sure hydraulic oil is at normal operating temperature by operating the machine under load for approximately ten (10) minutes.
2. Park machine on a level surface with the cutting units lowered and PTO switch off. Make sure engine is off. Apply the parking brake.
3. Read Precautions For Hydraulic Testing in this section.



CAUTION

Before opening hydraulic system, operate all hydraulic controls to relieve system pressure and avoid injury from pressurized hydraulic oil. See Relieving Hydraulic System Pressure in the General Information section of this chapter.

4. Raise and prop operator seat to allow access to hydraulic pump.

5. Identify suspected bad pump section to be tested (Fig. 40). Thoroughly clean junction of gear pump fitting and hydraulic outlet hose. Disconnect hose from pump fitting:

Pump section (P1) for rear cutting units

Pump section (P2) for front cutting units

IMPORTANT: Make sure that the oil flow indicator arrow on the flow gauge is showing that the oil will flow from the gear pump, through the tester and into the hose.

6. Install tester with pressure gauges and flow meter in series between disconnected hose and gear pump fitting. **Make sure the flow control valve on tester is fully open.**

7. After installing tester, start engine and run at idle speed. Check for any hydraulic leakage from test connections and correct before proceeding with test.

8. Make sure the parking brake is engaged. Move throttle to full speed (**3200 RPM**). **DO NOT** engage the cutting units. Use a tachometer to verify that engine speed is correct.

IMPORTANT: The gear pump is a positive displacement type. If pump flow is completely restricted or stopped, damage to the pump, tester or other components could occur.

9. While watching pressure gauges, slowly close the tester flow control valve until **2000 PSI (138 bar)** is obtained on gauge.

FLOW TESTER READING TO BE:

For RM5210 and 5410 machines, a pump in good condition should have a flow of approximately **6.4 GPM (24.2 LPM)** at **2000 PSI (138 bar)**.

For RM5510 and 5610 machines, a pump in good condition should have a flow of approximately **8.4 GPM (31.8 LPM)** at **2000 PSI (138 bar)**.

10. Open the tester flow control valve and stop the engine. Record test results.

11. If flow is less than **5.4 GPM (20.6 LPM)** on a RM5210/5410 machine, less than **7.1 GPM (27 LPM)** on a RM5510/5610 machine or a pressure of **2000 PSI (138 bar)** cannot be obtained, consider that a pump problem exists. Check for restriction in pump intake line. If intake is not restricted, remove gear pump and repair or replace pump as necessary (see Gear Pump and Gear Pump Service in the Service and Repairs section of this chapter).

12. After testing is completed, make sure that engine is stopped, then relieve hydraulic system pressure (See Relieving Hydraulic System Pressure in the General Information section of this chapter). Remove tester from machine and connect hydraulic hose to gear pump fitting.

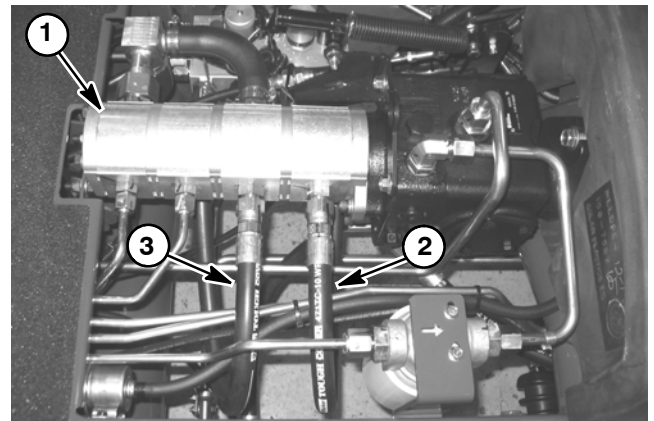

Figure 40

- 1. Gear pump
- 2. Pump P1 outlet (rear)
- 3. Pump P2 outlet (front)

Reel Drive Motor Efficiency Test (Using Tester with Pressure Gauges and Flow Meter)

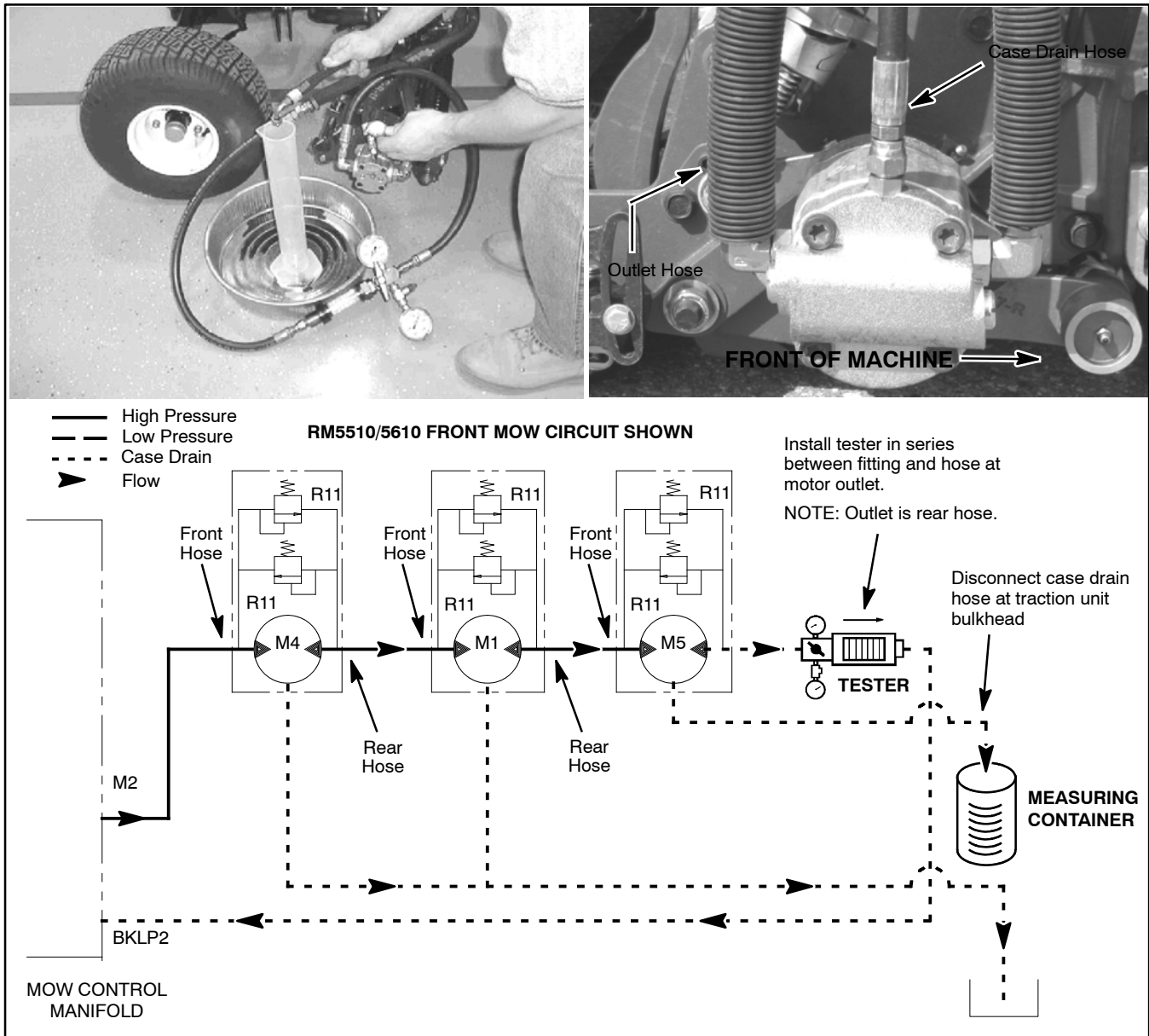

Figure 41

NOTE: Over a period of time, a reel motor can wear internally. A worn motor may by-pass oil to its case drain causing the motor to be less efficient. Eventually, enough oil loss will cause the reel motor to stall under heavy cutting conditions. Continued operation with a worn, inefficient motor can generate excessive heat, cause damage to seals and other components in the hydraulic system and affect quality of cut.

NOTE: One way to find a faulty reel motor is to have another person observe the machine while mowing in dense turf. A faulty motor will run slower than other motors, produce fewer clippings and may cause clip marks (a choppy appearance) on the turf.

Procedure for Reel Drive Motor Efficiency Test

1. Make sure hydraulic oil is at normal operating temperature by operating the machine under load for approximately ten (10) minutes.
2. Determine which reel motor is malfunctioning.
3. Park machine on a level surface with the cutting units lowered and PTO switch off. Make sure engine is off and mow/transport lever is in mow. Apply the parking brake.
4. Read Precautions For Hydraulic Testing in this section.



CAUTION

Before opening hydraulic system, operate all hydraulic controls to relieve system pressure and avoid injury from pressurized hydraulic oil. See Relieving Hydraulic System Pressure in the General Information section of this chapter.

NOTE: The reel motors are connected in series. To isolate a faulty motor, all motors in the circuit may have to be tested by starting with the upstream motor first.

5. For reel motor to be tested, thoroughly clean junction of the motor case drain hose (small diameter hose) where it connects to traction unit bulkhead (not at the motor) (Fig. 42). Disconnect the case drain hose and put a steel cap on the fitting at the traction unit. Leave the case drain hose from the motor open and place open end of disconnected hose into a drain pan.

IMPORTANT: Make sure that the oil flow indicator arrow on the flow gauge is showing that the oil will flow from the reel motor, through the tester and into the return hose.

6. On reel motor to be tested, thoroughly clean junction of hydraulic return hose (rear hose) and reel motor fitting. Disconnect return hose from the motor. Install tester with pressure gauges and flow meter in series with the motor and disconnected return hose. **Make sure the flow control valve on tester is fully open.**

7. Set reel speed control to the full speed position. Make sure Mow/Backlap lever is in the “**Mow**” position.

NOTE: Use a graduated container, special tool TOR4077, to measure case drain leakage (Fig. 41).

8. Start engine and run at idle speed. Check for any hydraulic leakage from test connections and correct before proceeding with test.



CAUTION

Cutting unit reels will rotate when performing the motor efficiency test. Keep away from cutting units during test to prevent personal injury from rotating reel blades. Do not stand in front of the machine.

9. Sit on seat and move throttle to full speed (**3200 RPM**). Press PTO switch to ON. Move “Lower-Mow/Raise” lever forward to engage cutting units.

10. While watching pressure gauges, slowly close flow control valve on tester until a pressure of **1200 PSI (83 bar)** is obtained.

11. After achieving **1200 PSI (83 bar)**, place disconnected motor case drain hose into a container graduated in ounces or milliliters (e.g. Toro #TOR4077) and collect hydraulic fluid for **15 seconds**. After **15 seconds**, remove hose end from container. Then move the PTO switch to OFF, open the tester flow control valve and stop the engine.

12. Identify amount of oil collected in the container. Record test results.

For Reelmaster 5210 and 5410 machines, if flow was greater than **16.0 ounces (473 milliliters) (.5 GPM/1.9 LPM)**, repair or replace the tested reel motor (see Cutting Reel Motor Service in the Service and Repairs section of this chapter).

For Reelmaster 5510 and 5610 machines, if flow was greater than **22.4 ounces (662 milliliters) (.7 GPM/2.6 LPM)**, repair or replace the tested reel motor (see Cutting Reel Motor Service in the Service and Repairs section of this chapter).

If flow is less than the listed specifications, the tested motor does not have excessive leakage.

13. After testing is completed, make sure that engine is stopped, then relieve hydraulic system pressure (See Relieving Hydraulic System Pressure in the General Information section of this chapter). Disconnect tester from motor and return hose. Connect return hose to the reel motor. Remove plug from machine fitting and connect case drain hose to the fitting.

14. If necessary, perform motor efficiency test on other reel motors.

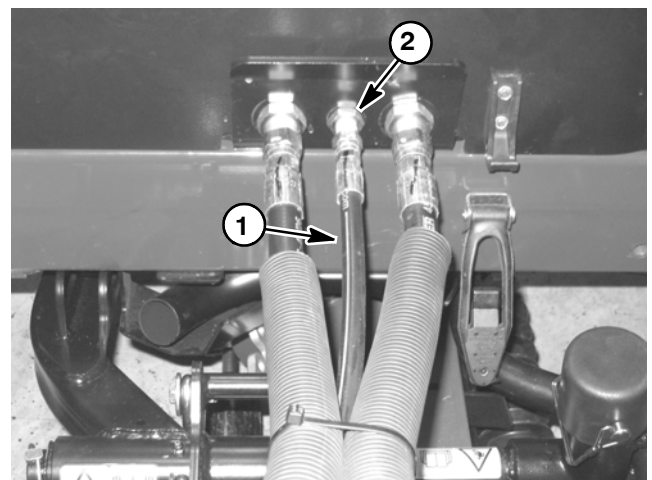

Figure 42

1. Case drain hose

2. Bulkhead fitting

Reel Drive Motor Cross-Over Relief Pressure Test (Reelmaster 5510 and 5610)

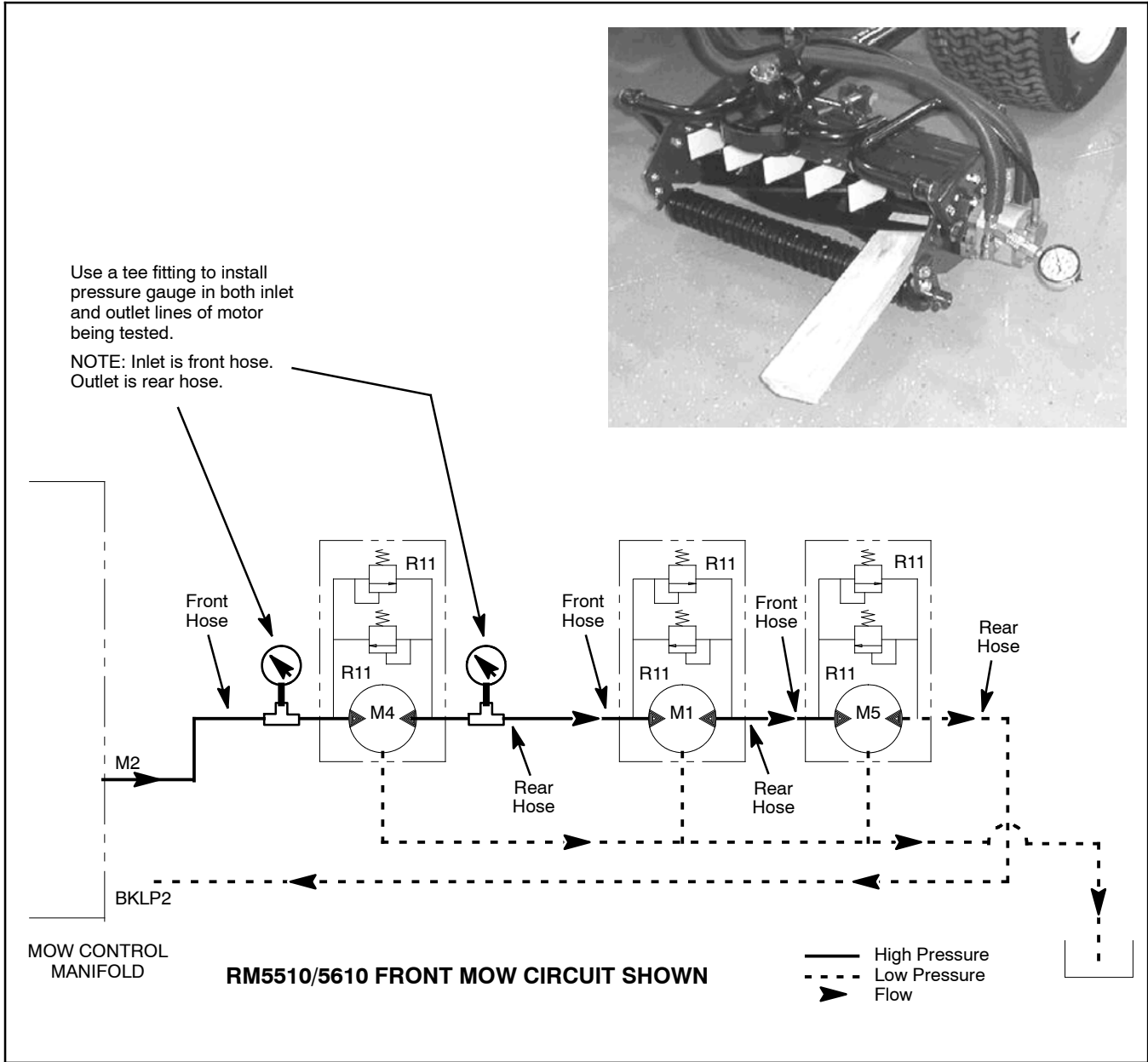

Figure 43

NOTE: One way to find a faulty reel motor is to have another person observe the machine while mowing in dense turf. A faulty motor will run slower, produce fewer clippings and may cause clip marks (a choppy appearance) on the turf.

IMPORTANT: DO NOT perform the Reel Drive Motor Cross-Over Relief Pressure Test on Reelmaster 5210 and 5410 machines. The reel motors on these machines do not have cross-over relief valves.

NOTE: Before testing the reel drive motor cross-over relief pressure, make sure that reel motor is in good condition by performing the Reel Drive Motor Efficiency Test (see Reel Drive Motor Efficiency Test in this section).

Procedure for Reel Drive Motor Cross-Over Relief Pressure Test

1. Make sure hydraulic oil is at normal operating temperature by operating the machine under load for approximately ten (10) minutes.
2. Determine which reel motor is malfunctioning.
3. Park machine on a level surface with the cutting units lowered and PTO switch off. Make sure engine is off and mow/transport lever is in mow. Apply the parking brake.
4. Read Precautions For Hydraulic Testing in this section.



CAUTION

Before opening hydraulic system, operate all hydraulic controls to relieve system pressure and avoid injury from pressurized hydraulic oil. See Relieving Hydraulic System Pressure in the General Information section of this chapter.

NOTE: The reel motors are connected in series. To isolate a faulty motor, all motors in the circuit may have to be tested by starting with the upstream motor (closest to the pump) first.

5. On reel motor to be tested, thoroughly clean junction of motor inlet and outlet fittings and hydraulic hoses. Loosen and remove both hoses from fittings. Install a tee fitting with a 5000 PSI (350 bar) pressure gauge between fitting and hose for both motor inlet and outlet (Fig. 44).
6. On the hydraulic mow control manifold, set reel speed control to the full speed position. Make sure Mow/Backlap lever is in the “**Mow**” position.
7. With cutting units in lowered position and engine OFF, insert a block of wood between cutting unit reel blades and carrier frame of cutting unit being tested to prevent reel from turning (Fig. 43).
8. Start engine and run at low idle speed. Check for any hydraulic leakage from test connections and correct before proceeding with test.



CAUTION

Adjacent cutting unit reels will rotate when performing the cross-over relief test. Keep away from cutting units during test to prevent personal injury from rotating reel blades. Do not stand in front of the machine.

9. One person should sit on the seat and operate the machine while another person closely monitors both pressure gauges connected to the reel motor. Make sure that engine speed is at low idle position (**1200 RPM**) and press PTO switch to ON. Move “Lower-Mow/Raise” lever forward to engage the cutting units.

10. There should be a slight hesitation in pressure increase on the inlet side of motor as the cross over relief valve opens. Once the relief valve is open, there will be a pressure differential between the gauges on the inlet and outlet side of the motor. Note and record this pressure difference which should be:

Pressure differential between the two gauges should be approximately 1800 PSI (124 bar)

11. Disengage the cutting units and stop the engine. If the measured pressure differential is not approximately **1800 PSI (124 bar)**, the cross-over relief valves on the tested motor may be leaking or damaged. Inspect relief valves in the reel motor (see Reel Motor Service in the Service and Repairs section of this chapter).

12. After testing is completed, make sure that engine is stopped, then relieve cutting unit hydraulic system pressure (see Relieving Hydraulic System Pressure in the General Information section of this chapter). Remove pressure gauges and tee fittings from machine. Connect hydraulic hoses to reel motor fittings.

13. If necessary, test other reel motors.

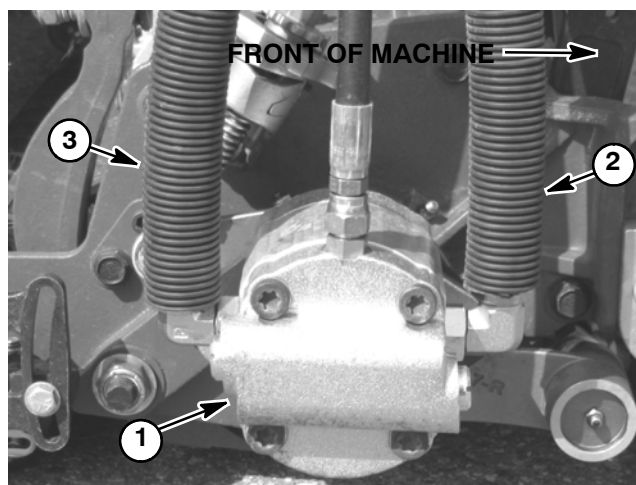

Figure 44

- | | |
|--------------------------|---------------------------|
| 1. Hydraulic reel motor | 3. Reel motor outlet hose |
| 2. Reel motor inlet hose | |

Lift Relief Valve (SVRV) Pressure Test

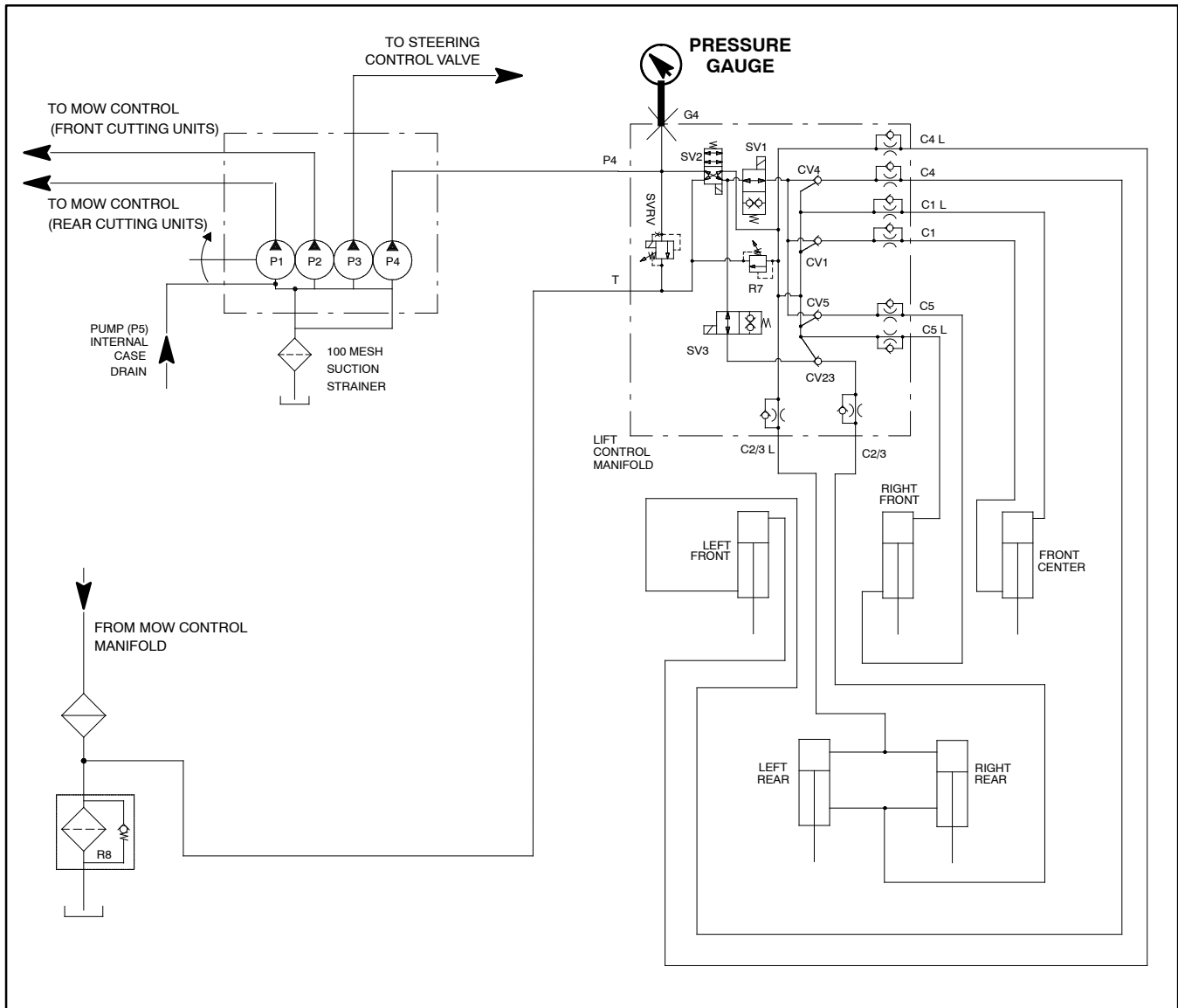

Figure 45

The lift relief valve (SVRV) pressure test should be performed to make sure that the lift circuit relief pressure is correct.

Procedure for Lift Relief Valve (SVRV) Pressure Test

1. Make sure hydraulic oil is at normal operating temperature by operating the machine under load for approximately ten (10) minutes.
2. Park machine on a level surface with the cutting units lowered and PTO switch off. Make sure engine is off. Apply the parking brake.
3. Read Precautions For Hydraulic Testing in this section.



CAUTION

Before opening hydraulic system, operate all hydraulic controls to relieve system pressure and avoid injury from pressurized hydraulic oil. See Relieving Hydraulic System Pressure in the General Information section of this chapter.

4. Gain access to hydraulic lift control manifold from below front of machine.

5. Thoroughly clean test port (G4) on lift control manifold. Access to test port can be obtained from below the front of the machine. Connect a 5000 PSI (350 bar) pressure gauge to test port.

6. After installing pressure gauge to manifold test port, start engine and run at idle speed. Check for any hydraulic leakage from test connections and correct before proceeding with test.

7. Move throttle to full speed (**3200 RPM**).

IMPORTANT: Do not allow pressure to exceed 2500 PSI (172 bar).

IMPORTANT: While performing this test, hold Lower - Mow/Raise lever in the raise position only long enough to get a system pressure reading. Holding the lever in raise for an extended period may damage system components.

8. Make sure that PTO switch is OFF and then pull Lower - Mow/Raise lever rearward to pressurize lift circuit. While holding lever in the raise (rearward) position, watch pressure gauge carefully. As the cutting units fully raise and the lift relief valve lifts, system pressure should be:

Approximately 2000 PSI (138 bar)

9. Return the Lower - Mow/Raise lever to the neutral position and stop the engine.

10. If measured pressure is incorrect, remove solenoid relief valve (SVRV) on lift control manifold and clean or replace valve (see Lift Control Manifold Service in the Service and Repairs section of this chapter). Also, if pressure is low, check for restriction in pump intake line. Internal lift cylinder leakage would also cause low lift circuit pressure (see Lift Cylinder Internal Leakage Test in this section). Gear pump (P4) could also be suspected of wear, damage or inefficiency.

11. After testing is completed, make sure that engine is stopped, then relieve hydraulic system pressure (See Relieving Hydraulic System Pressure in the General Information section of this chapter). Disconnect pressure gauge from lift control manifold test port.

Gear Pump (P4) Flow Test (Using Tester with Pressure Gauges and Flow Meter)

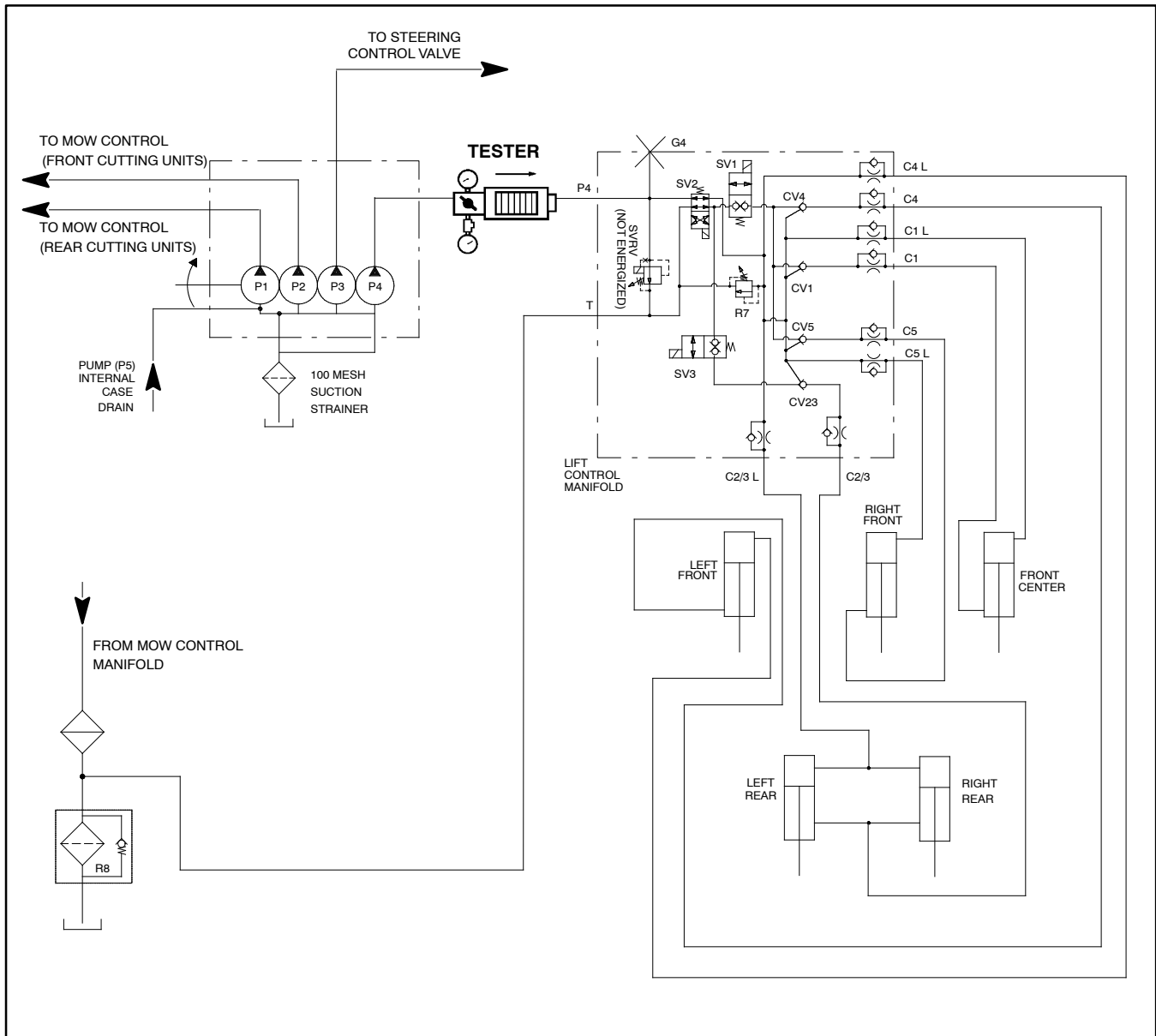

Figure 46

The gear pump (P4) flow test should be performed to make sure that the cutting unit lift circuit has adequate hydraulic flow.

Procedure for Gear Pump (P4) Flow Test

1. Make sure hydraulic oil is at normal operating temperature by operating the machine under load for approximately ten (10) minutes.
2. Park machine on a level surface with the cutting units lowered and PTO switch off. Make sure engine is off. Apply the parking brake.

3. Read Precautions For Hydraulic Testing in this section.



CAUTION

Before opening hydraulic system, operate all hydraulic controls to relieve system pressure and avoid injury from pressurized hydraulic oil. See Relieving Hydraulic System Pressure in the General Information section of this chapter.

4. Raise and prop operator seat to allow access to hydraulic pump.

5. Thoroughly clean both ends of the hydraulic tube that connects gear pump (P4) outlet (Fig. 47) and lift control manifold P4 port. Remove hydraulic tube. Access to hydraulic tube at lift control manifold can be obtained from below the machine.

IMPORTANT: Make sure that the oil flow indicator arrow on the flow meter is showing that the oil will flow from pump (P4), through the tester and to the lift control manifold.

6. Install tester with pressure gauges and flow meter in place of the removed hydraulic tube. Connect tester inlet hose to the pump fitting. Connect the tester outlet hose to the lift control manifold fitting. **Make sure the flow control valve on tester is fully open.**

7. Make sure that the traction pedal is in neutral and the parking brake is engaged.

8. Start engine and run at idle speed. Check for any hydraulic leakage from test connections and correct before proceeding with test.

9. Move throttle to full speed (**3200 RPM**). Use a tachometer to verify that engine speed is correct.

IMPORTANT: The gear pump is a positive displacement type. If pump flow is completely restricted or stopped, damage to the pump, tester or other components could occur.

10. While carefully watching pressure gauges, slowly close the tester flow control valve until **1000 PSI (69 bar)** is obtained on gauge.

FLOW TESTER READING TO BE: A pump in good condition should have a flow of approximately **3 GPM (11.4 LPM)** at **1000 PSI (69 bar)**.

11. Open the tester flow control valve, stop engine and record test results.

12. If flow is less than **2.5 GPM (9.6 LPM)** or a pressure of **1000 PSI (69 bar)** cannot be obtained, consider that a pump problem exists. Check for restriction in pump intake line. If intake is not restricted, remove gear pump and repair or replace pump as necessary (see Gear Pump in the Service and Repairs section of this chapter).

NOTE: If the flow from gear pump (P4) is low, the operation of all lift cylinders will be affected.

13. After testing is completed, make sure that engine is stopped, then relieve hydraulic system pressure (See Relieving Hydraulic System Pressure in the General Information section of this chapter). Connect removed hydraulic tube to gear pump (P4) outlet and lift control manifold P4 port.

14. Lower and secure operator seat.

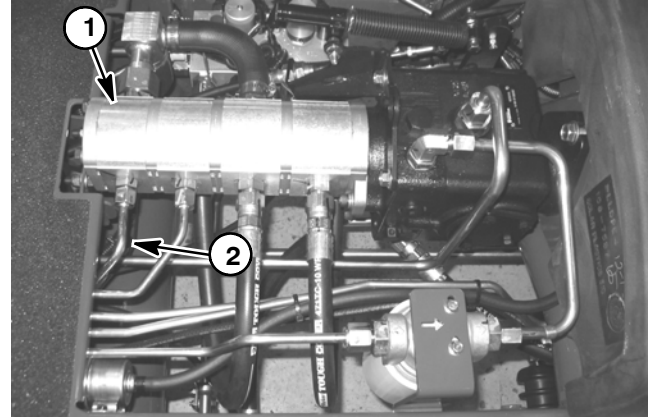

Figure 47

1. Gear Pump (P4)

2. Hydraulic tube

Lift Cylinder Internal Leakage Test

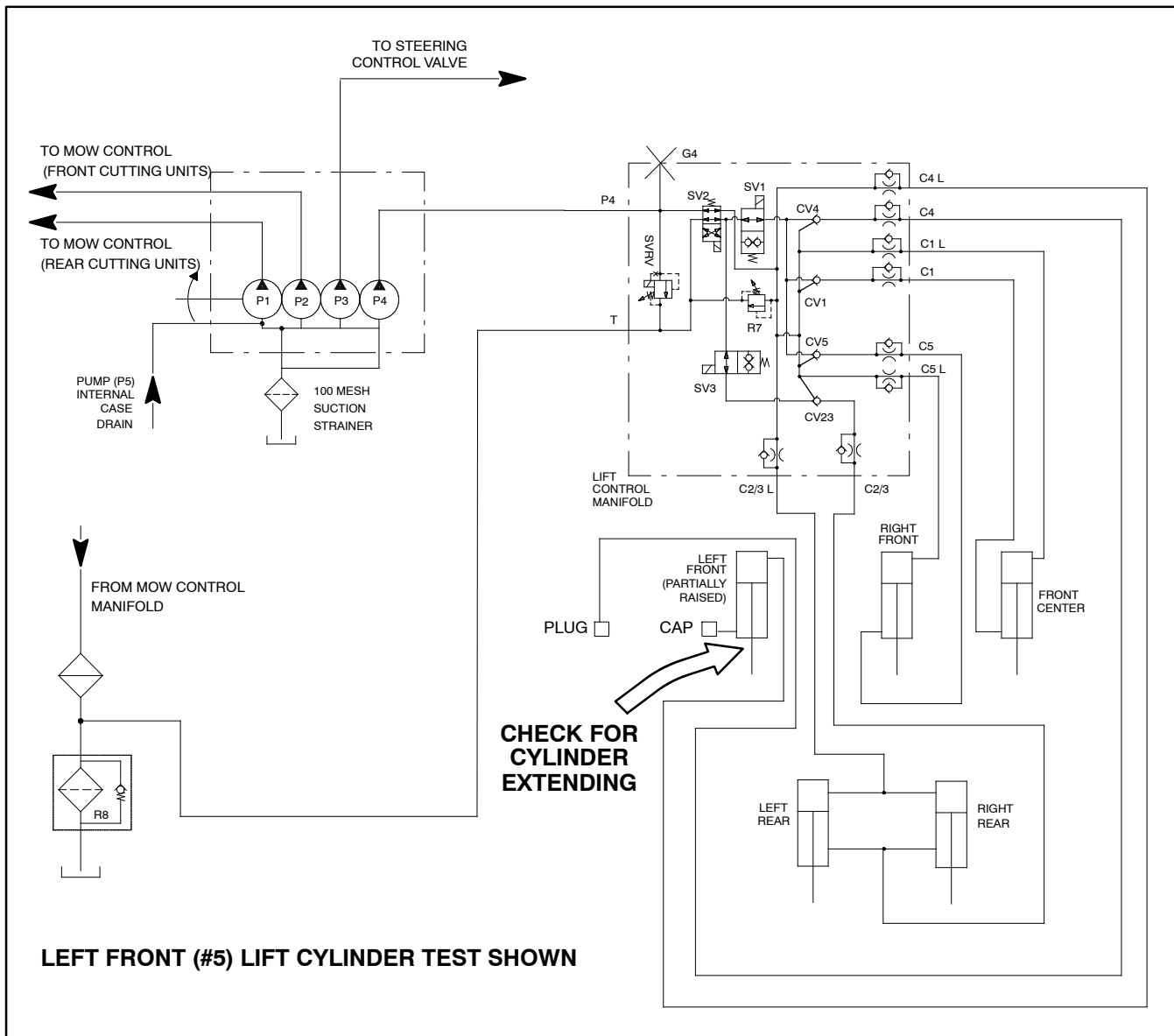

Figure 48

The lift cylinder internal leakage test should be performed if a cutting unit raise and lower problem is identified. This test will determine if a lift cylinder is faulty.

NOTE: Cutting unit raise/lower circuit operation will be affected by lift cylinder binding, extra weight on the cutting units and/or binding of lift components. Make sure that these items are checked before proceeding with lift cylinder internal leakage test.

Procedure for Lift Cylinder Internal Leakage Test:

1. Park machine on a level surface with the PTO switch OFF. Position the cutting units in the turn-around position and turn the engine off. Apply the parking brake.

2. For the lift cylinder that is to be tested, use a jack to raise the lift arm slightly. This will remove the load from the lift cylinder and relieve lift cylinder hydraulic pressure. Leave the jack under the lift arm to support the lift arm and to prevent the lift arm from lowering.

NOTE: If either of the rear lift cylinders is being tested, both rear lift arms need to be supported.

3. Thoroughly clean the area around the end of the hydraulic hose at the rod end of the lift cylinder. Disconnect the hydraulic hose from the lift cylinder rod end fitting (Fig. 49).

IMPORTANT: When capping lift cylinder fitting and hydraulic hose end, use a steel cap and plug to ensure that fluid leakage will not occur. Plastic plugs will not hold hydraulic pressure that will be developed during this test procedure.

4. Place a steel cap on the open lift cylinder fitting to seal the lift cylinder. Also, install a steel plug in the open end of the disconnected hose to prevent leakage or contamination.

5. Slowly lower the jack and remove it from under the lift arm. The cutting unit should settle slightly and then be supported by the capped lift cylinder.

6. Mark the position of the lift cylinder rod at the lift cylinder head with a piece of tape (Fig. 50).

7. Leave the machine parked for two (2) hours and monitor the lift cylinder. The weight of the cutting unit may cause the lift cylinder to gradually extend. Use the tape location to determine lift cylinder rod movement (Fig. 51).

A. If lift cylinder rod movement is less than 1.250" (31.7 mm) after two (2) hours, make sure that the cutting unit has not settled to the ground. If the cutting unit is still suspended after two (2) hours and lift cylinder rod movement is less than 1.250" (31.7 mm), consider that the lift cylinder is in good condition. A cylinder in good, usable condition will show minimal movement.

B. Rod movement in excess of 1.250" (31.7 mm) after two (2) hours indicates that the lift cylinder may have internal seal damage or excessive wear. Remove and inspect the lift cylinder (see Lift Cylinder and Lift Cylinder Service in the Service and Repairs section of this chapter).

8. Once lift cylinder condition has been determined, use a jack to raise the lift arm slightly which will remove the load from the lift cylinder. Leave the jack to support the lift arm and to prevent it from lowering. Remove the cap from the cylinder fitting and the plug from the hydraulic hose. Connect the hydraulic hose to the lift cylinder fitting.

9. Remove jack from under the lift arm. Start engine and operate lift cylinders through several up and down cycles. Stop the engine and check for any leakage.

10. If needed, repeat steps 2 through 10 for other lift cylinders.

11. Check oil level in hydraulic reservoir.

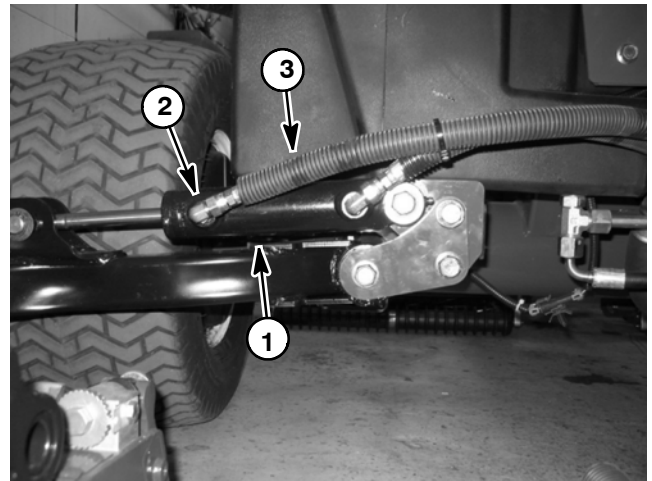

Figure 49

- 1. Lift cylinder (#5 shown)
- 2. Cylinder rod end fitting
- 3. Hydraulic hose

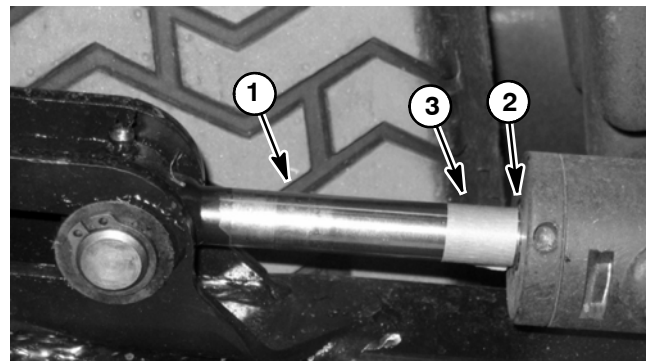

Figure 50

- 1. Lift cylinder rod
- 2. Lift cylinder head
- 3. Tape (initial position)

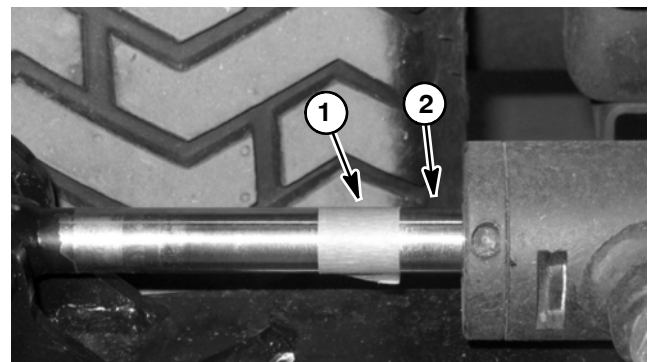

Figure 51

- 1. Tape (after 2 hours)
- 2. Cylinder rod movement

Steering Relief Valve (R10) Pressure Test

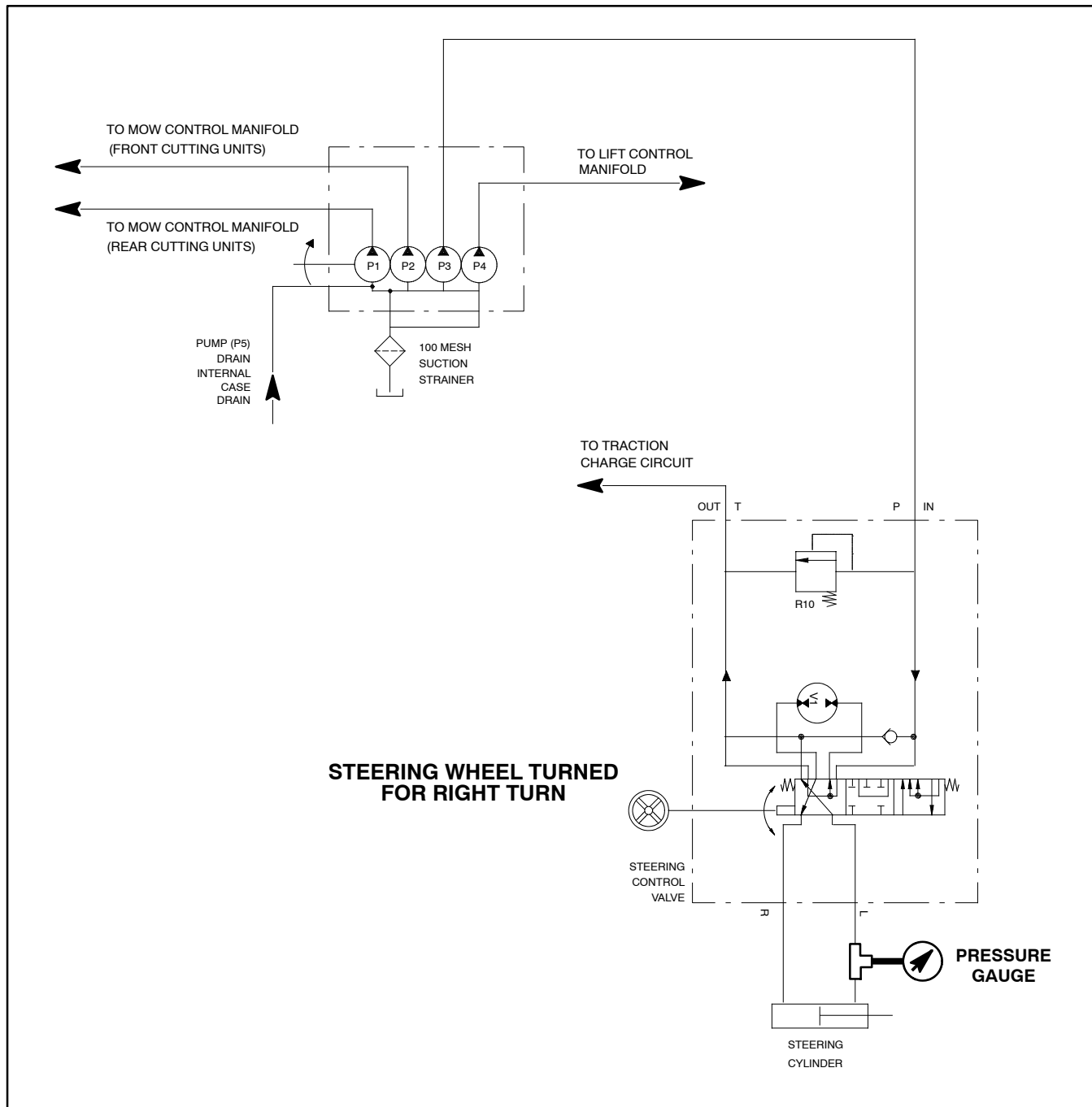

Figure 52

The steering relief valve (R10) pressure test should be performed to make sure that the steering circuit relief pressure is correct.

Procedure for Steering Relief Valve Pressure Test:

1. Make sure hydraulic oil is at normal operating temperature by operating the machine under load for approximately ten (10) minutes.
2. Park machine on a level surface with the cutting units lowered and PTO switch off. Make sure engine is off. Apply the parking brake.
3. Read Precautions For Hydraulic Testing in this section.

**CAUTION**

Before opening hydraulic system, operate all hydraulic controls to relieve system pressure and avoid injury from pressurized hydraulic oil. See Relieving Hydraulic System Pressure in the General Information section of this chapter.

4. Thoroughly clean the area around the hydraulic hose at the rod end of the steering cylinder (Fig. 53).
5. Remove hydraulic hose from the fitting on the rod end of the steering cylinder.
6. Install a tee fitting between the disconnected hydraulic hose and the steering cylinder fitting. Install a 5000 PSI (350 bar) pressure gauge to the tee fitting.
7. After installing pressure gauge, start engine and run at idle speed. Check for any hydraulic leakage from test connections and correct before proceeding with test.
8. Move throttle to full speed (**3200 RPM**).

IMPORTANT: Hold steering wheel at full lock only long enough to get a system pressure reading. Holding the steering wheel against the stop for an extended period may damage the steering control valve.

9. Watch pressure gauge carefully while turning the steering wheel for a left hand turn (counter-clockwise) and holding.

10. System pressure should be approximately **1000 PSI (69 bar)** as the relief valve lifts. Return steering wheel to the neutral position.

11. Shut off engine. Record test results.

12. If specification is **not** met, repair or replace steering control valve (relief valve in steering control valve is not replaceable).

13. After testing is completed, make sure that engine is stopped, then relieve hydraulic system pressure (See Relieving Hydraulic System Pressure in the General Information section of this chapter). Remove tee fitting and pressure gauge from hydraulic hose and steering cylinder. Connect hydraulic hose to steering cylinder fitting.

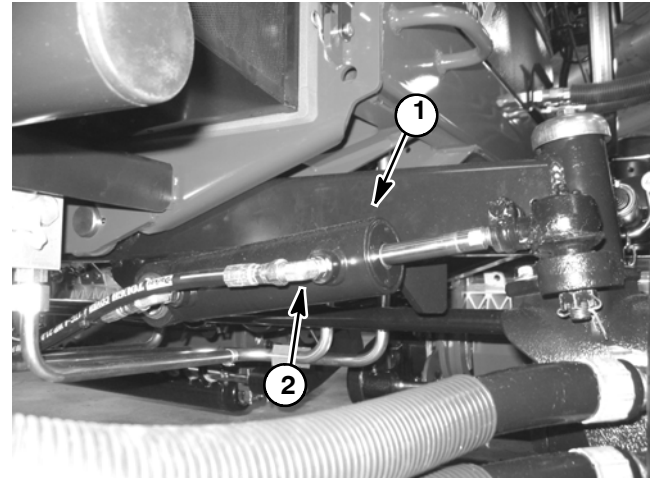

Figure 53

1. Steering cylinder
2. Rod end fitting

Steering Cylinder Internal Leakage Test

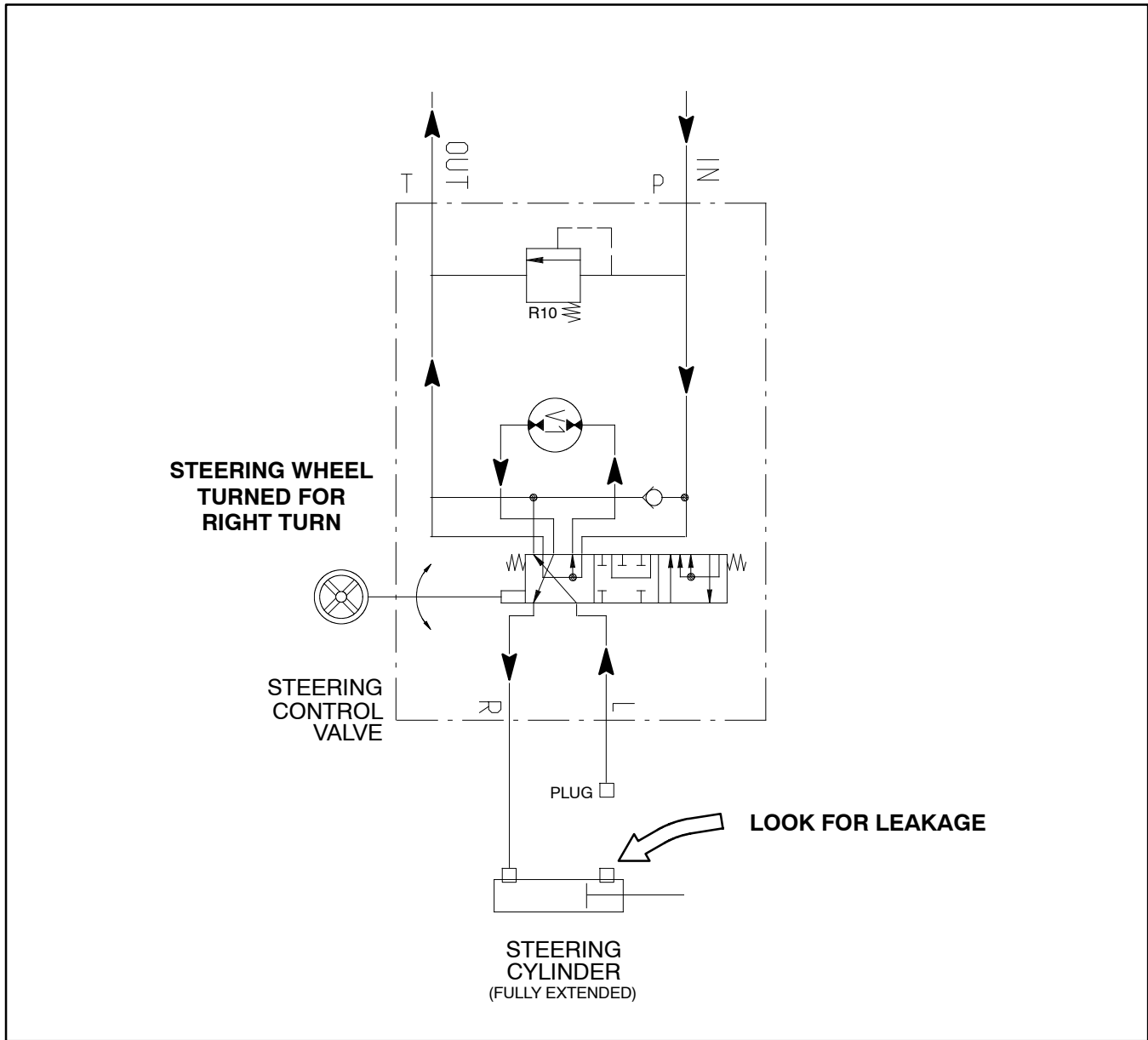

Figure 54

The steering cylinder internal leakage test should be performed if a steering problem is identified. This test will determine if the steering cylinder is faulty.

NOTE: Steering circuit operation will be affected by rear tire pressure, steering cylinder binding, extra weight on the vehicle and/or binding of rear axle steering components. Make sure that these items are checked before proceeding with steering cylinder internal leakage test.

Procedure for Steering Cylinder Internal Leakage Test:

1. Make sure hydraulic oil is at normal operating temperature by operating the machine under load for approximately ten (10) minutes.
2. Park machine on a level surface with the cutting units lowered and PTO switch off. Make sure engine is off. Apply the parking brake.
3. Read Precautions For Hydraulic Testing.

	CAUTION
Before opening hydraulic system, operate all hydraulic controls to relieve system pressure and avoid injury from pressurized hydraulic oil. See Relieving Hydraulic System Pressure in the General Information section of this chapter.	

4. Turn the steering wheel for a right turn (clockwise) so the steering cylinder rod is fully extended.
5. Thoroughly clean the area around the hydraulic hose at the rod end of the steering cylinder (Fig. 55).
6. Place a drain pan under the steering cylinder. Remove hydraulic hose from the fitting on the rod end of the steering cylinder. Plug the end of the hose.
7. Remove all hydraulic oil from drain pan. Make sure that empty drain pan remains under the open fitting of the steering cylinder.
8. With the engine off, continue turning the steering wheel for a right turn (clockwise) with the steering cylinder fully extended. Observe the open fitting on the steering cylinder as the wheel is turned. If oil comes out of the fitting while turning the steering wheel to the right, the steering cylinder has internal leakage and must be repaired or replaced (see Steering Cylinder and Steering Cylinder Service in the Service and Repairs section of this chapter). Check drain pan for any evidence of oil that would indicate cylinder leakage.
9. Remove plug from the hydraulic hose. Connect hose to the steering cylinder fitting.
10. If a steering problem exists and the steering cylinder tested acceptably, the steering control valve requires service (see Steering Control Valve and Steering Control Valve Service in the Service and Repairs section of this chapter).
11. Check oil level in hydraulic reservoir and adjust if needed.

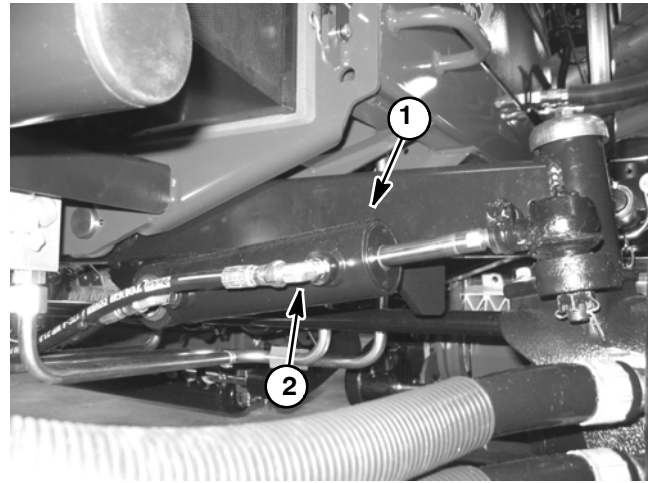

Figure 55

1. Steering cylinder 2. Rod end fitting

Service and Repairs

General Precautions for Removing and Installing Hydraulic System Components

Before Repair or Replacement of Components

1. Before removing any parts from the hydraulic system, park machine on a level surface, engage parking brake, lower cutting units and stop engine. Remove key from the ignition switch.
2. Thoroughly clean machine before disconnecting, removing or disassembling any hydraulic components. Make sure hydraulic components, hose connections and fittings are thoroughly cleaned. Always keep in mind the need for cleanliness when working on hydraulic components.



CAUTION

Before loosening any hydraulic component, operate all hydraulic controls to relieve system pressure and avoid injury from pressurized hydraulic oil. See Relieving Hydraulic System Pressure in the General Information section of this chapter.

3. Operate all hydraulic controls to relieve system pressure before loosening any hydraulic connection (see Relieving Hydraulic System Pressure in the General Information section).
4. Put caps or plugs on any hydraulic lines, hydraulic fittings or components left open or exposed to prevent contamination.
5. Before disconnecting hydraulic lines and hoses, place labels to ensure proper installation after repairs are completed.
6. Note the position of hydraulic fittings (especially elbow fittings) on hydraulic components before removal. Mark parts if necessary to make sure that fittings will be aligned properly when reinstalling hydraulic hoses and tubes.

After Repair or Replacement of Components

1. If component failure is severe or hydraulic system is contaminated, flush hydraulic system (see Flush Hydraulic System in this section).
2. Lubricate O-rings and seals with clean hydraulic oil before installing hydraulic components.
3. Make sure all caps or plugs are removed from hydraulic tubes, hydraulic fittings and components before reconnecting.
4. Use proper tightening methods when installing hydraulic hoses and fittings (see Hydraulic Fitting Installation in the General Information section of this chapter).
5. After repairs, check control linkages and cables for proper adjustment, binding or broken parts.
6. After disconnecting or replacing any hydraulic components, operate machine functions slowly until air is out of system (see Hydraulic System Start Up in this section).
7. Check for hydraulic oil leaks. If any leaks are discovered, shut off engine and correct leaks.
8. Check oil level in hydraulic reservoir and add correct oil if necessary.

Check Hydraulic Lines and Hoses



CAUTION

Keep body and hands away from pin hole leaks or nozzles that eject hydraulic fluid under high pressure. Use paper or cardboard, not hands, to search for leaks. Hydraulic fluid escaping under pressure can have sufficient force to penetrate the skin and cause serious injury. If fluid is injected into the skin, it must be surgically removed within a few hours by a doctor familiar with this type of injury. Gangrene may result from such an injury.

Check hydraulic lines and hoses daily for leaks, kinked lines, loose mounting supports, wear, loose fittings, weather deterioration and chemical deterioration. Make all necessary repairs before operating the machine.

Flush Hydraulic System

IMPORTANT: Flush the hydraulic system any time there is a severe component failure or the system is contaminated. Contaminated oil appears milky or black or contains metal particles.

1. Park machine on a level surface. Lower cutting units, stop engine, engage parking brake and remove key from ignition switch.

2. Drain hydraulic reservoir.

3. Clean area around the mounting areas of the hydraulic filters. Remove and discard hydraulic filters.

4. Drain entire hydraulic system. Drain all hoses, tubes and components while the system is warm. Flush hoses and tubes to remove any contamination.

IMPORTANT: If a failure occurred in the traction circuit, traction circuit component disassembly and thorough cleaning may be required to remove contaminants from the traction circuit. Because the traction circuit is a closed loop, any contamination will remain in the circuit and can cause additional component damage unless it is removed.

5. Make sure the mounting surfaces of the hydraulic filters are clean. Apply clean hydraulic oil to gasket on new filters. Screw filters on until gasket contacts mounting plate, then tighten filter 3/4 turn.

IMPORTANT: Use only hydraulic fluids specified in Traction Unit Operator's Manual. Other fluids could cause system damage.

6. Fill hydraulic reservoir with new hydraulic oil.

7. Disconnect electrical connector to the fuel stop solenoid to prevent the engine from starting.

8. Make sure traction pedal is in neutral and the PTO switch is OFF. Turn ignition key switch to start; engage starter for ten (10) seconds to prime hydraulic pumps. Repeat this step again.

9. Connect fuel stop solenoid to allow engine to start.

10. Start engine and let it idle at low speed for a minimum of two (2) minutes.

11. Increase engine speed to high idle for minimum of one (1) minute under no load.

12. Rotate steering wheel in both directions several times. Raise and lower cutting units several times.

13. Shut off engine and check for hydraulic oil leaks. Check oil level in hydraulic reservoir and add correct oil if necessary.

14. Operate the machine for two (2) hours under normal operating conditions.

15. Check condition of hydraulic oil. If the fluid shows any signs of contamination, repeat steps 1 through 14 again.

16. Resume normal operation and follow recommended maintenance intervals.

Filtering Closed- Loop Traction Circuit

Filtering of a closed- loop hydraulic system after a major component failure (e.g. traction (piston) pump or wheel motor) is a requirement to prevent debris from transmitting throughout the system. If a closed- loop hydraulic system filtering tool is not used to ensure system cleanliness, repeat failures, as well as subsequent damage to other hydraulic components in the affected system, will occur. To effectively remove contamination from closed- loop traction circuit, use of the Toro high flow hydraulic filter and hydraulic hose kits are recommended (see Special Tools in this chapter).

1. Park machine on a level surface with engine stopped and key removed from ignition switch.
2. Raise and support machine so all wheels are off the ground (see Jacking Instructions in Chapter 1 - Safety).

NOTE: If wheel motor was replaced, install high flow filter to the inlet of the new motor instead of to the traction pump fitting. This will prevent system contamination from entering and damaging the new wheel motor.

3. Thoroughly clean junction of hydraulic hose and **left** side elbow fitting on bottom of traction pump (Fig. 56). Disconnect hose from left side pump fitting.
4. Connect Toro high flow hydraulic filter in series between traction pump fitting and disconnected hose. Use hydraulic hose kit (see Special Tools in this chapter) to connect filter to machine. Make sure that fitting and hose connections are properly tightened.

IMPORTANT: Use only hydraulic fluids specified in Operator's Manual. Other fluids could cause system damage.

5. After installing high flow filter to machine, check and fill hydraulic reservoir with new hydraulic oil as required.
6. Start engine and run at idle speed. Check for any hydraulic leakage from filter and hose connections. Correct any leaks before proceeding.

CAUTION

All wheels will be off the ground and rotating during this procedure. Make sure machine is well supported so it will not move and accidentally fall to prevent injuring anyone around machine.

IMPORTANT: While engaging the traction circuit, monitor the indicator on the high flow hydraulic filter. If the indicator should show red, either reduce pressure on the traction pedal or reduce engine speed to decrease hydraulic flow through the filter.

7. With engine running at low idle speed, slowly move the traction pedal to the forward direction to allow flow through the traction circuit and high flow filter. Keep traction circuit engaged for five (5) minutes while gradually increasing both forward pressure on traction pedal and engine speed. Monitor filter indicator to make sure that green color is showing during operation.
8. With engine running at high idle speed and traction pedal moved to the forward direction, periodically apply brakes to increase pressure in traction circuit. While monitoring filter indicator, continue this process for an additional five (5) minutes.

IMPORTANT: If using a filter that is not the Toro high flow filter that is bi-directional, do not press the traction pedal in the reverse direction. If flow is reversed when using a filter that is not bi-directional, debris from the filter will re-enter the traction circuit.

9. With engine running at high idle speed, alternately move traction pedal from forward to reverse. While monitoring filter indicator, continue this process for an additional five (5) minutes.
10. Shut engine off and remove key from ignition switch.
11. Remove high flow hydraulic filter and hydraulic hose kit from machine. Connect hydraulic hose to left side traction pump fitting. Make sure to properly tighten hose (see Hydraulic Hose and Tube Installation in the General Information section of this chapter).
12. Lower machine to ground.
13. Check oil level in hydraulic reservoir and add correct oil if necessary.

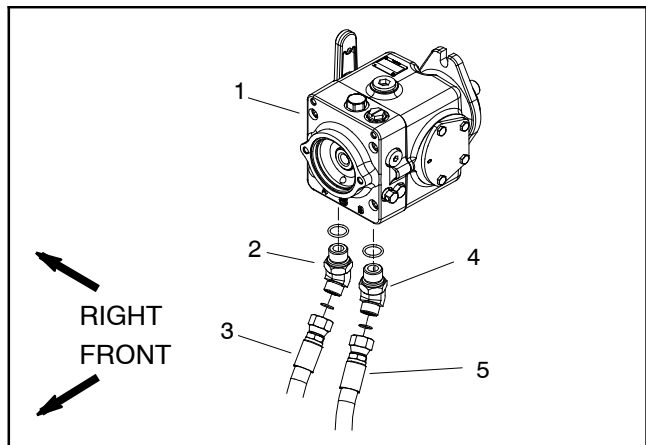

Figure 56

- | | |
|-----------------------|-----------------------|
| 1. Traction pump | 4. LH elbow fitting |
| 2. RH elbow fitting | 5. Hyd hose (reverse) |
| 3. Hyd hose (forward) | |

Hydraulic System Start-up

NOTE: When initially starting the hydraulic system with new or rebuilt components such as pumps, wheel motors or lift cylinders, it is important that this start-up procedure be used. This procedure reduces the chance of damaging the system or its components from not purging the system of air.

1. After the hydraulic system components have been properly installed and if the traction pump was rebuilt or replaced, make sure traction pump housing is at least half full of clean hydraulic oil.

2. Make sure all hydraulic connections and lines are secured tightly.

3. Drain, flush and refill hydraulic system and change hydraulic oil filters if component failure was severe or system is contaminated (see Flush Hydraulic System in this section).

4. Make sure hydraulic reservoir is full. Add correct oil if necessary.

5. Check control linkage for proper adjustment, binding or broken parts.

6. Disconnect electrical connector to the engine fuel stop solenoid to prevent the engine from starting.

7. Make sure traction pedal is in neutral and the PTO switch is OFF. Turn ignition key switch to start; engage starter for ten (10) seconds to prime hydraulic pumps. Repeat this step again.

8. Connect fuel stop solenoid to allow engine to start.

9. Make sure traction pedal is in neutral and the PTO switch is OFF. Start engine and run it at low idle. The charge pump should pick up oil and fill the hydraulic system. If there is no indication of fill in 30 seconds, stop the engine and determine the cause.

10. If the traction pump was replaced or rebuilt, run the traction unit so the wheels turn slowly for 10 minutes.

11. Operate the traction unit (including steering and cutting unit lift/lower) by gradually increasing the work load to full over a 10 minute period.

12. Stop the machine. Check oil level in hydraulic reservoir and add correct oil if necessary. Check hydraulic components for leaks and tighten any loose connections.

This page is intentionally blank.

Hydraulic Reservoir

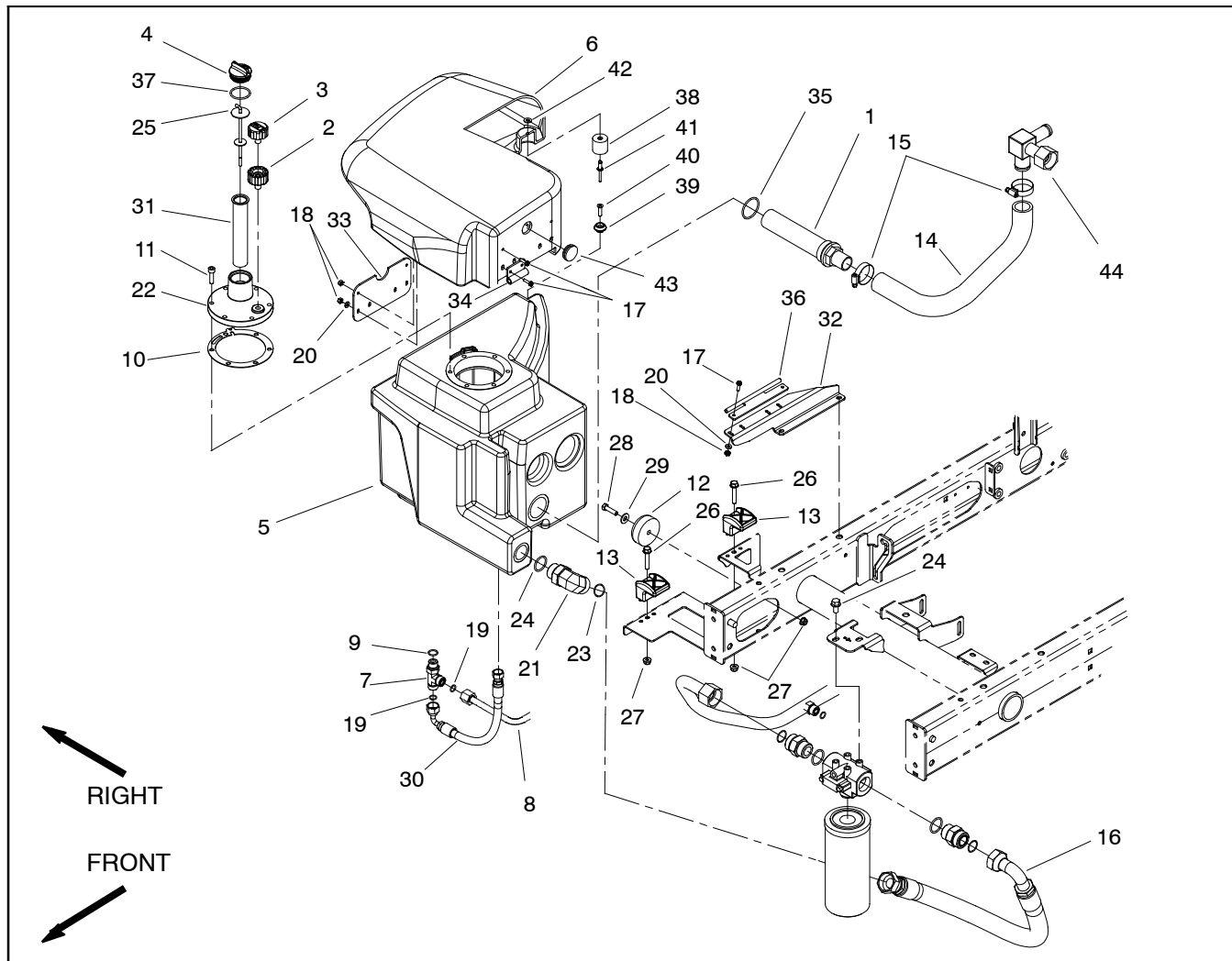

Figure 57

- | | | |
|--------------------------------|--------------------------------|-----------------------|
| 1. Suction strainer | 16. Hydraulic hose | 31. Filter screen |
| 2. Breather adapter | 17. Screw (8 used) | 32. Hinge bracket |
| 3. Breather | 18. Lock nut (8 used) | 33. Hinge plate |
| 4. Plastic plug | 19. O-ring | 34. Hinge (2 used) |
| 5. Oil reservoir | 20. Flat washer (6 used) | 35. O-ring |
| 6. Tank cover | 21. Hydraulic fitting | 36. Pin assembly |
| 7. Hydraulic tee fitting | 22. Tank cap | 37. O-ring |
| 8. Hydraulic tube | 23. O-ring | 38. Rubber receptacle |
| 9. O-ring | 24. O-ring | 39. Holding post |
| 10. Flange gasket | 25. Dipstick | 40. Screw |
| 11. Socket head screw (6 used) | 26. Washer head screw (2 used) | 41. Rivet |
| 12. Bumper | 27. Flange nut (3 used) | 42. Flat washer |
| 13. Clamp (2 used) | 28. Cap screw | 43. Plug grommet |
| 14. Hydraulic hose | 29. Flat washer | 44. Manifold tube |
| 15. Hose clamp (2 used) | 30. Hydraulic hose | |

Removal (Fig. 57)

1. Tilt hydraulic reservoir cover up to access reservoir.
2. Thoroughly clean hydraulic hose ends and fittings on hydraulic reservoir to prevent hydraulic system contamination.
3. Drain hydraulic oil from reservoir.
4. Label hydraulic hoses to assist in installation. Disconnect all hydraulic hoses and tubes from fittings on the reservoir. Allow hydraulic lines to drain into a suitable container. Plug or cap openings of reservoir and lines to prevent contamination.
5. Remove hydraulic reservoir using Figure 57 as a guide.
6. Remove suction strainer from reservoir. Discard O-ring.
7. If hydraulic fittings are to be removed from reservoir, mark fitting orientation to allow correct assembly. Remove fittings from reservoir and discard O-rings.

Inspection (Fig. 57)

1. Clean hydraulic reservoir and suction strainer with solvent.
2. Inspect hydraulic reservoir for leaks, cracks or other damage.

Installation (Fig. 57)

1. If fittings were removed from reservoir, lubricate and place new O-rings onto fittings. Install fittings into reservoir openings using marks made during the removal process to properly orientate fittings. Tighten fittings (see Hydraulic Fitting Installation in the General Information section of this chapter).
2. Lubricate new suction strainer O-ring and install onto strainer. Thread suction strainer into hydraulic reservoir until finger tight. Then, using a wrench, turn strainer into reservoir port 1 - 1/2 to 2 full turns beyond finger tight.
3. Position hydraulic reservoir to machine. Secure reservoir to frame with two (2) clamps (item 13), washer head screws (item 26) and flange nuts (item 27).
4. Remove all plugs and caps placed in hoses and fittings during the removal process.
5. Install hydraulic hoses to fittings on hydraulic reservoir in positions noted during removal.
6. Fill hydraulic reservoir with **new** hydraulic fluid.
7. Lower and secure reservoir cover.
8. Operate machine. Check hydraulic lines and fittings for leaks. Tighten any loose connections. Check hydraulic oil level and adjust if necessary.

Hydraulic Pump Drive Shaft

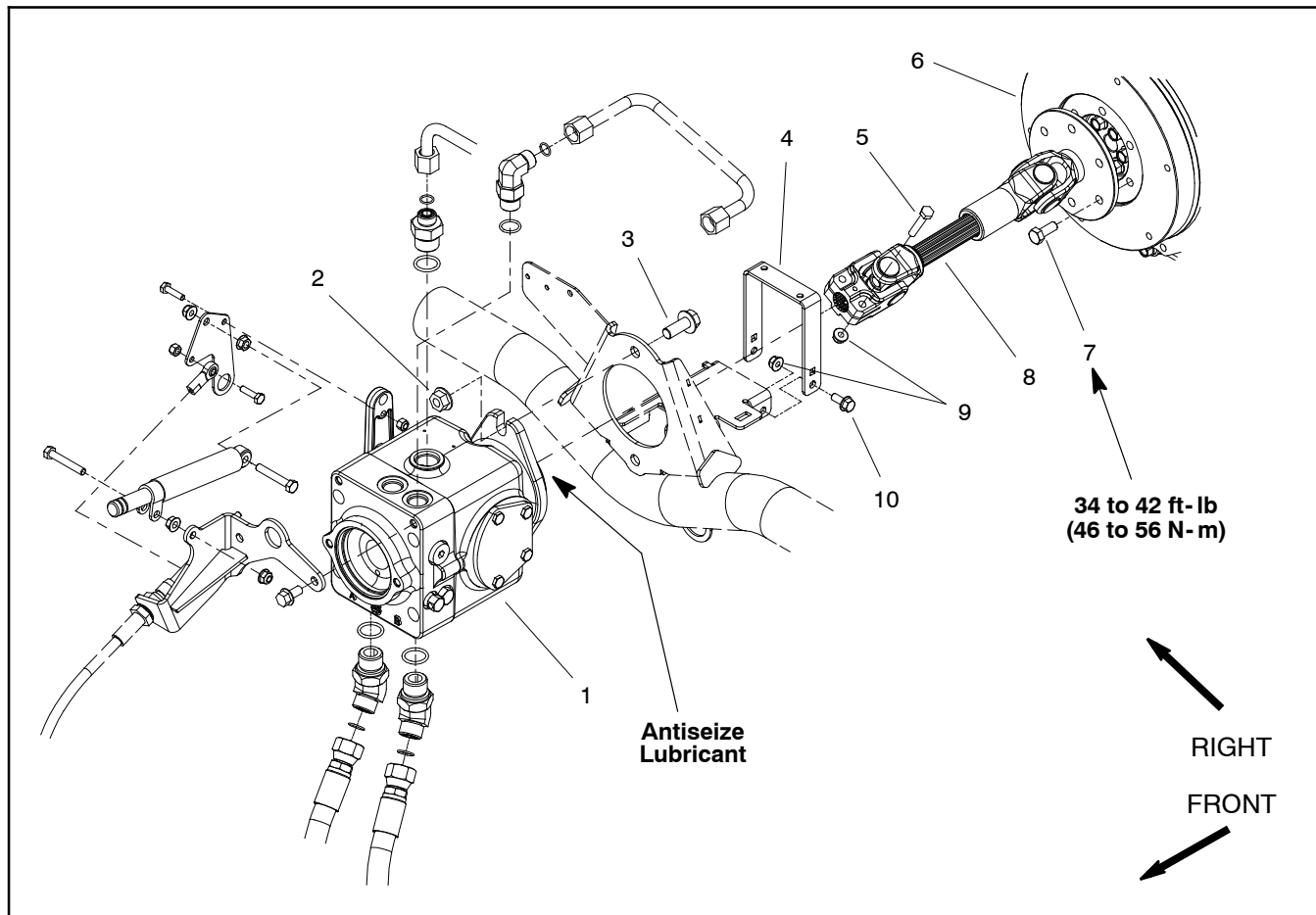

Figure 58

- | | | |
|-------------------------------|-----------------------|--------------------------------|
| 1. Piston (traction) pump | 5. Cap screw (2 used) | 8. Drive shaft assembly |
| 2. Flange nut (2 used) | 6. Engine flywheel | 9. Flange nut |
| 3. Flange head screw (2 used) | 7. Cap screw (6 used) | 10. Flange head screw (2 used) |
| 4. Guard hoop | | |

Removal (Fig. 58)

1. Park the machine on a level surface, engage parking brake, lower cutting units and stop engine. Remove key from the ignition switch.
2. Remove two (2) flange head screws and flange nuts that secure drive shaft guard hoop to machine frame. Remove guard.
3. Remove two (2) cap screws (item 5) and flange nuts (item 9) that secure drive shaft yoke to piston pump input shaft.
4. Remove six (6) cap screws (item 7) that secure drive shaft flange to engine flywheel.
5. Remove drive shaft assembly from machine.

Drive Shaft Cross and Bearing Service (Fig. 59)

1. Remove snap rings that secure bearings in yokes.

IMPORTANT: Yokes must be supported when removing and installing bearings to prevent damage.

2. Use a press to remove cross and bearings from yokes. Thoroughly clean drive shaft yokes.

3. To install new cross and bearings:

A. Apply a coating of grease to bearing bores in end yoke and shaft yoke.

B. Press one bearing partially into yoke.

C. Insert cross into yoke and bearing.

D. Hold cross in alignment and press bearing in until it hits the yoke.

E. Install snap ring into yoke groove to secure installed bearing.

F. Place second bearing into yoke bore and onto cross shaft. Press bearing into yoke and secure with snap ring.

G. Repeat procedure for other yoke.

H. Grease cross until grease comes out of all four (4) cups.

4. Make sure that assembled joint moves without binding. Slight binding can usually be eliminated by lightly rapping the yoke lugs with a soft faced hammer. If binding continues, disassemble joint to identify source of binding.

Installation (Fig. 58)

1. Apply antiseize lubricant to traction pump input shaft.
2. Position drive shaft assembly to engine and pump input shaft.
3. Secure drive shaft flange to engine flywheel with six (6) cap screws (item 7). Torque cap screws from **34 to 42 ft-lb (46 to 56 N-m)**.
4. Secure drive shaft yoke to pump input shaft with two (2) cap screws (item 5) and flange nuts (item 9).
5. Position drive shaft guard hoop to machine frame and secure with two (2) flange head screws and flange nuts.
6. Lubricate grease fittings on drive shaft.

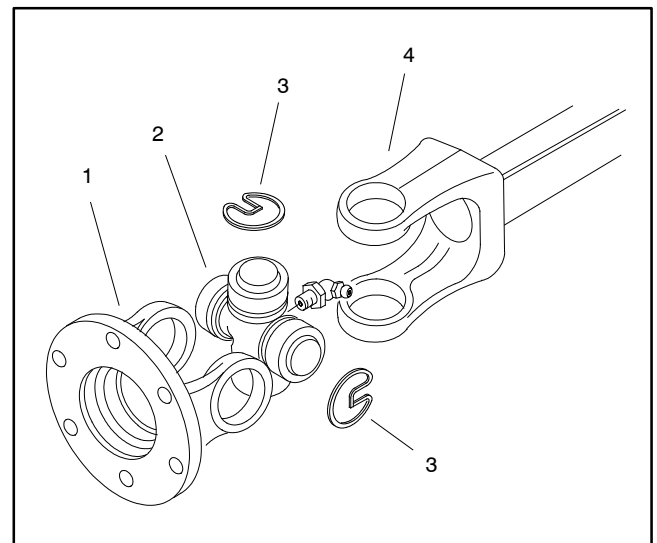

Figure 59

- | | |
|--------------------------|-----------------------|
| 1. End yoke | 3. Snap ring (4 used) |
| 2. Cross and bearing kit | 4. Shaft yoke |

Hydraulic Pump Assembly

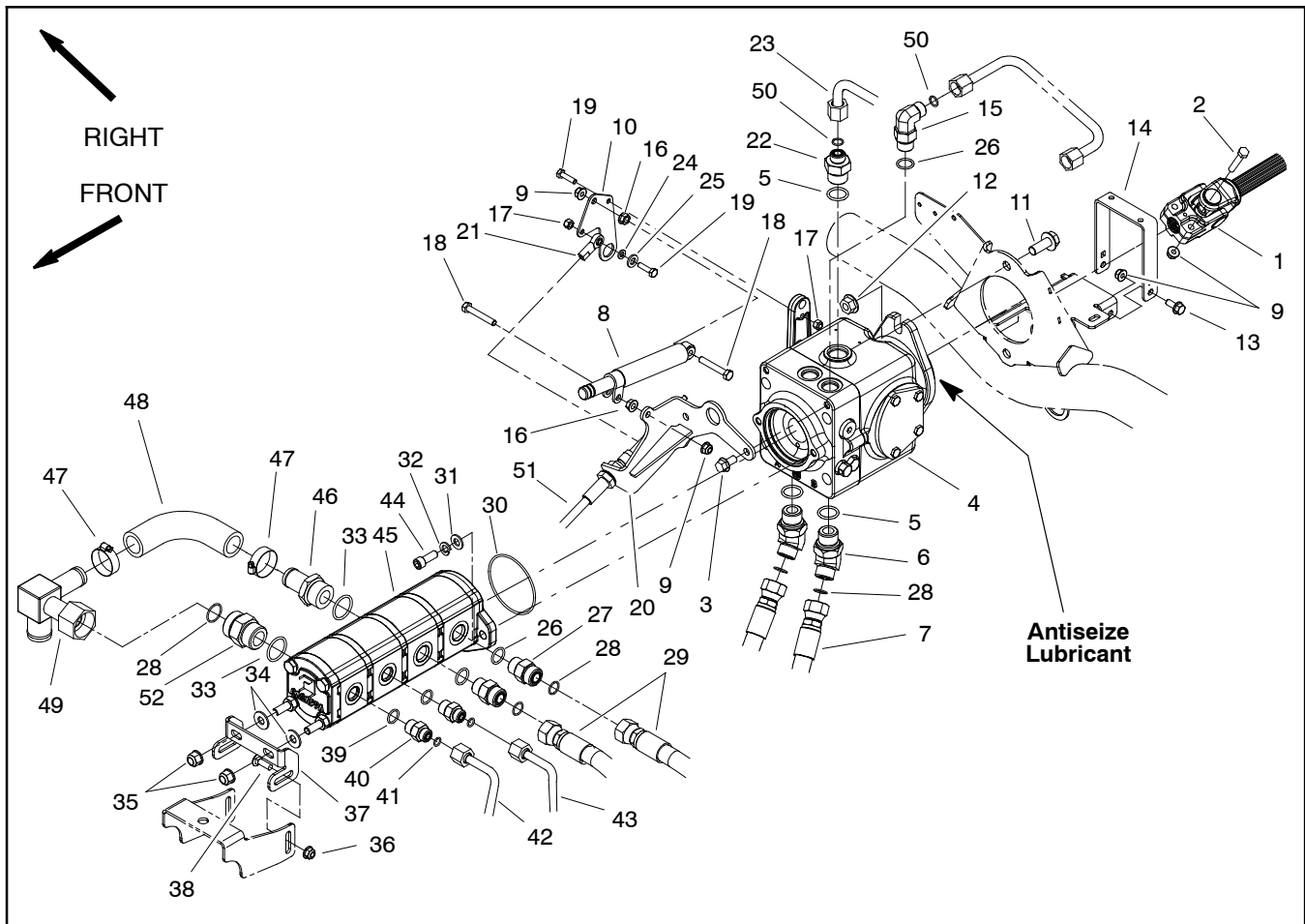

Figure 60

- | | | |
|--------------------------------|--------------------------------|--------------------------------|
| 1. Drive shaft assembly | 19. Cap screw | 36. Flange nut (2 used) |
| 2. Cap screw (2 used) | 20. Bracket | 37. Pump support bracket |
| 3. Flange head screw (2 used) | 21. Traction cable ball joint | 38. Carriage screw (2 used) |
| 4. Traction pump assembly | 22. Hydraulic fitting | 39. O-ring |
| 5. O-ring | 23. Hydraulic tube | 40. Hydraulic fitting (2 used) |
| 6. Hydraulic fitting (2 used) | 24. Flat washer | 41. O-ring |
| 7. Hydraulic hose (2 used) | 25. Flat washer | 42. Hydraulic tube |
| 8. Lever damper | 26. O-ring | 43. Hydraulic tube |
| 9. Flange nut | 27. Hydraulic fitting (2 used) | 44. Socket head screw |
| 10. Plate | 28. O-ring | 45. Gear pump assembly |
| 11. Flange head screw (2 used) | 29. Hydraulic hose | 46. Hydraulic fitting |
| 12. Flange nut (2 used) | 30. O-ring | 47. Hose clamp |
| 13. Flange head screw (2 used) | 31. Flat washer (2 used) | 48. Hydraulic hose |
| 14. Guard hoop | 32. Lock washer (2 used) | 49. Tube manifold |
| 15. Hydraulic fitting | 33. O-ring | 50. O-ring |
| 16. Flange nut | 34. Flat washer (2 used) | 51. Traction cable |
| 17. Lock nut | 35. Lock nut (2 used) | 52. Hydraulic fitting |
| 18. Cap screw | | |

NOTE: Traction pump and gear pump should be removed from machine as an assembly. Once removed from machine, pumps can be separated for service.

Removal (Fig. 60)

1. Park the machine on a level surface, engage parking brake, lower cutting units and stop engine. Remove key from the ignition switch.
2. Read the General Precautions for Removing and Installing Hydraulic System Components at the beginning of the Service and Repairs section of this chapter.



CAUTION

Before opening hydraulic system, operate all hydraulic controls to relieve system pressure and avoid injury from pressurized hydraulic oil. See Relieving Hydraulic System Pressure in the General Information section of this chapter.

3. To prevent contamination of the hydraulic system, thoroughly clean traction and gear pump assembly and all hydraulic connections.
4. Label hydraulic hoses to assist in assembly. Disconnect all hydraulic hoses and tubes from fittings on the traction and gear pump assembly. Allow hydraulic lines to drain into a suitable container. Plug or cap openings of pumps and lines to prevent contamination.
5. Remove hydraulic pump drive shaft (see Hydraulic Pump Drive Shaft Removal in this section).
6. Remove cap screw and lock nut that secure plate (item 10) to pump lever. Remove two (2) flange head screws (item 3) that secure cable bracket to traction pump. Carefully position traction control cable and bracket away from traction pump.
7. Disconnect harness electrical connector from traction neutral switch and position harness away from transmission.



CAUTION

Make sure lift or hoist can support the total weight of the pump assembly before removing the cap screws from the engine and engine brackets. Pump assembly weighs approximately 67 pounds (30.5 kg).

8. Connect a lift or hoist to hole in traction cable bracket on traction pump to support pump assembly and for pump removal.
9. Loosen and remove two (2) carriage screws (item 38) and flange nuts (item 36) that secure pump support bracket to frame.

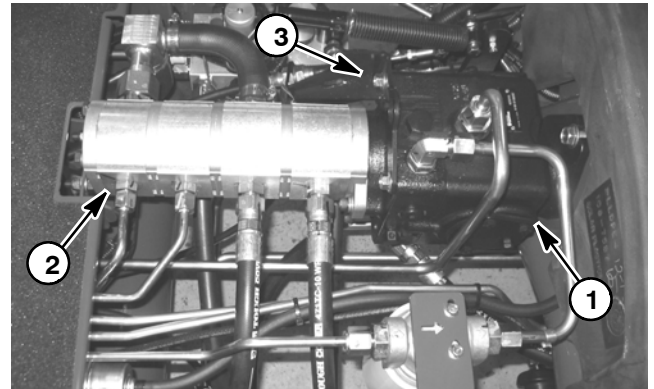

Figure 61

1. Piston (traction) pump
2. Gear pump
3. Traction cable bracket

10. Remove two (2) flange screws and flange nuts that secure traction pump flange to machine frame.

IMPORTANT: Make sure to not damage machine components while removing the pump assembly.

11. Carefully lift pump assembly from the machine.
12. Remove two (2) socket head screws, lock washers and flat washers that secure gear pump to traction pump. Remove gear pump from traction pump. Locate and discard O-ring (item 30) from between pumps.
13. If necessary, remove hydraulic fittings from pumps. Note orientation of fittings for assembly purposes.
14. If necessary, remove two (2) lock nuts (item 35) that secure pump support bracket (item 37) to gear pump. Remove bracket and two (2) flat washers from gear pump.
15. Remove and discard all O-rings from removed hydraulic lines and fittings.

Installation (Fig. 60)

1. If fittings were removed from pump assembly, lightly lubricate new fitting O-rings with clean hydraulic oil. Install fittings with O-rings to the pump assembly (see Hydraulic Fitting Installation in the General Information section of this chapter). Orientate fittings as noted during removal.
2. If pump support bracket (item 37) was removed from gear pump, fit flat washers and bracket to gear pump and secure with two (2) lock nuts.
3. Lubricate and position new O-ring (item 30) between pumps. Position gear pump to traction pump and secure with two (2) socket head screws, lock washers and flat washers.

IMPORTANT: Make sure to not damage machine components while installing the pump assembly.

4. Carefully lower pump assembly to machine frame.
5. Secure pump assembly to machine frame with two (2) flange screws and flange nuts.
6. Secure pump support bracket to inside of frame bracket with two (2) carriage screws (item 38) and flange nuts (item 36).
7. Install hydraulic hoses to fittings on pump assembly in positions noted during removal.
8. Connect machine harness electrical connector to traction neutral switch.
9. Position traction control cable to traction pump lever and secure plate (item 10) to pump lever with cap screw and lock nut. Secure cable bracket to traction pump with two (2) flange head screws.
10. Install hydraulic pump drive shaft (see Hydraulic Pump Drive Shaft Installation in this section).
11. Check oil level in hydraulic reservoir and add correct oil if necessary.
12. Follow Hydraulic System Start-up procedures (see Hydraulic System Start-up in this section).
13. Check traction drive for neutral and traction neutral switch operation. Adjust if necessary.

This page is intentionally blank.

Piston (Traction) Pump Service

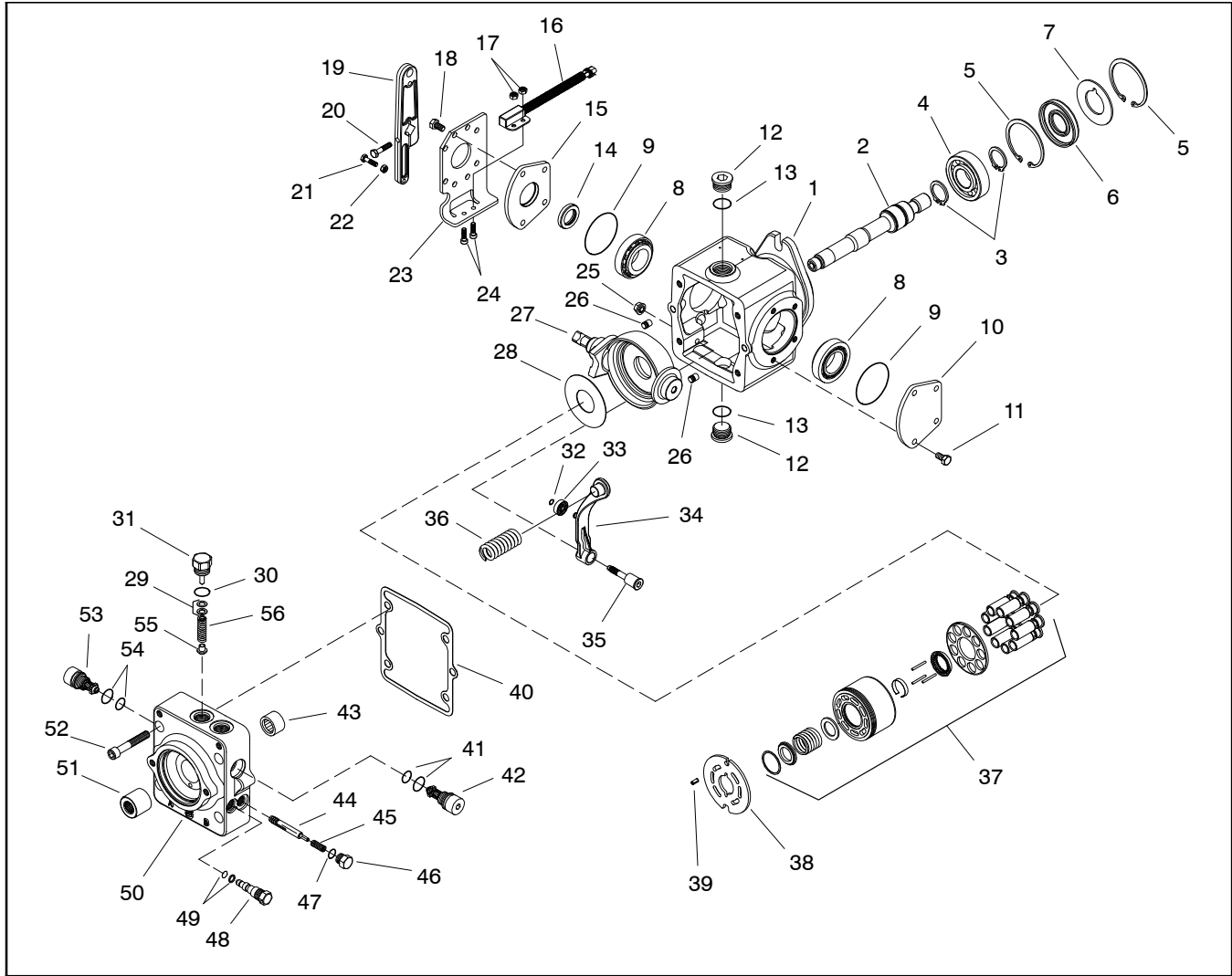

Figure 62

- | | | |
|--------------------------|--------------------------|----------------------------|
| 1. Traction pump housing | 20. Screw | 39. Slotted pin |
| 2. Auxiliary shaft | 21. Screw | 40. End cap gasket |
| 3. Retaining ring | 22. Jam nut | 41. Seal kit |
| 4. Ball bearing | 23. Bracket | 42. Relief valve (reverse) |
| 5. Retaining ring | 24. Screw | 43. Needle bearing |
| 6. Seal | 25. Seal nut | 44. Loop flushing spool |
| 7. Backup washer | 26. Pin | 45. Spring |
| 8. Bearing | 27. Swashplate | 46. Plug |
| 9. O-ring | 28. Thrust plate | 47. O-ring |
| 10. Trunnion cover | 29. Shim kit | 48. Bypass valve |
| 11. Screw (4 used) | 30. O-ring | 49. Seal kit |
| 12. Plug | 31. Charge relief plug | 50. End cap |
| 13. O-ring | 32. Retaining ring | 51. Coupling |
| 14. Seal | 33. Bearing | 52. Screw (4 used) |
| 15. Trunnion cover | 34. Neutral return arm | 53. Relief valve (forward) |
| 16. Neutral switch | 35. Neutral return pivot | 54. Seal kit |
| 17. Lock nut | 36. Spring | 55. Charge relief poppet |
| 18. Screw (4 used) | 37. Cylinder block kit | 56. Spring |
| 19. Control arm | 38. Valve plate | |

NOTE: For piston (traction) pump repair information, see the Sauer- Danfoss LPV Closed Circuit Axial Piston Pumps Repair Manual and Service Instructions at the end of this chapter.

IMPORTANT: If a piston (traction) pump failure occurred, refer to Traction Circuit Component Failure in the General Information section for information regarding the importance of removing contamination from the traction circuit.

Three (3) styles of traction control assemblies have been used on Reelmaster 5010 machines. Machines with a serial number below 310000000 use traction control components as shown in Fig. 62. Machines with a serial number from 310000001 to 310999999 include control components that are shown in Fig. 63. Machines with a serial number above 311000001 use control components that are shown in Fig. 64.

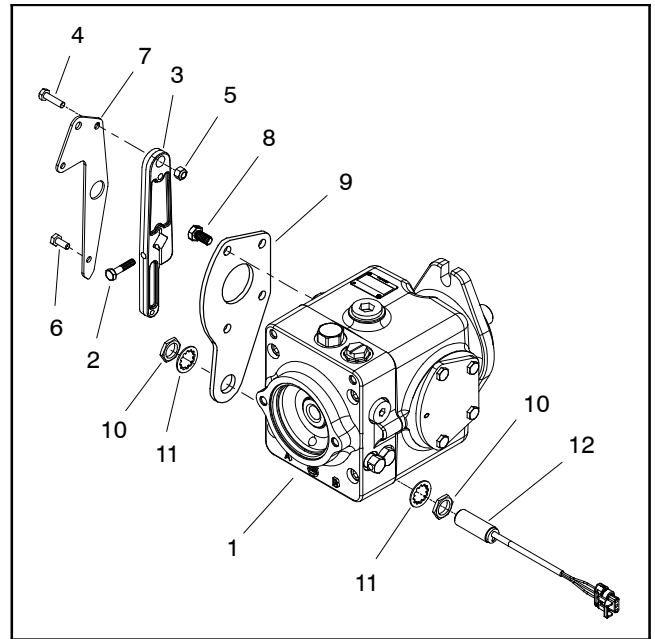

Figure 63

- | | |
|---------------------------|---------------------------|
| 1. Piston (traction) pump | 7. Traction lever bracket |
| 2. Screw | 8. Cap screw (4 used) |
| 3. Pump control arm | 9. Pump plate |
| 4. Cap screw | 10. Jam nut (2 used) |
| 5. Lock nut | 11. Lock washer (2 used) |
| 6. Cap screw | 12. Neutral switch |

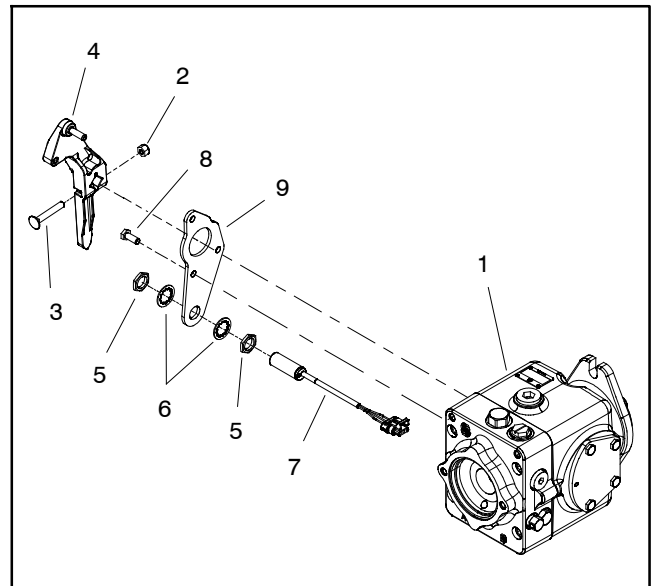

Figure 64

- | | |
|---------------------------|-------------------------|
| 1. Piston (traction) pump | 6. Lock washer (2 used) |
| 2. Lock nut | 7. Neutral switch |
| 3. Carriage screw | 8. Cap screw (3 used) |
| 4. Pump lever | 9. Pump plate |
| 5. Jam nut (2 used) | |

Gear Pump Service

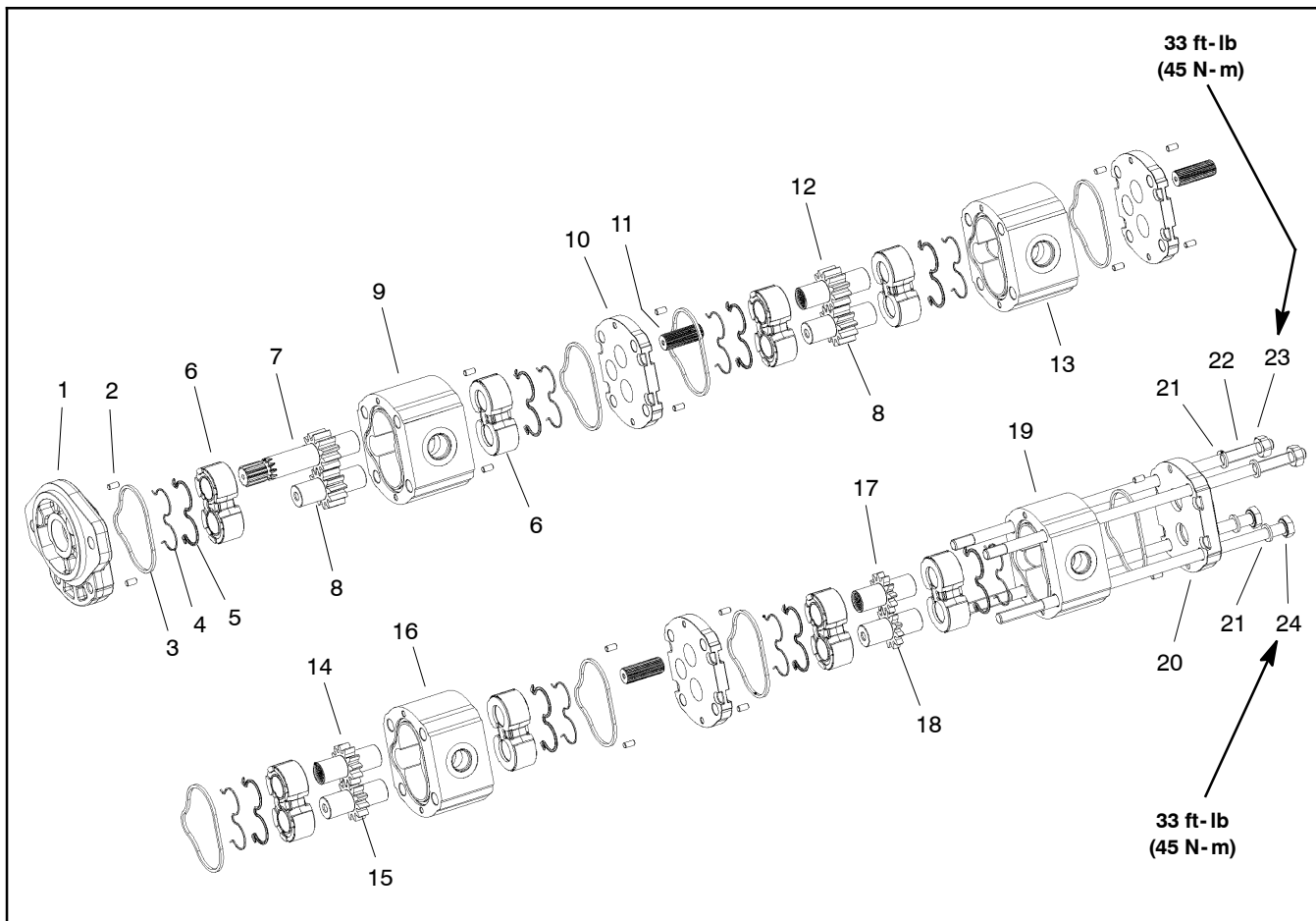

Figure 65

- | | | |
|---------------------------------|---------------------------------------|------------------------|
| 1. Front cover | 9. Body | 17. Drive gear |
| 2. Dowel pin (16 used) | 10. Flange (3 used) | 18. Driven gear |
| 3. Square section seal (8 used) | 11. Splined connecting shaft (3 used) | 19. Body |
| 4. Back-up ring (8 used) | 12. Drive gear | 20. Rear cover |
| 5. Pressure seal (8 used) | 13. Body | 21. Washer (4 used) |
| 6. Thrust plate (8 used) | 14. Drive gear | 22. Stud bolt (2 used) |
| 7. Drive shaft | 15. Driven gear | 23. Nut (2 used) |
| 8. Driven gear (2 used) | 16. Body | 24. Cap screw (2 used) |

Disassembly (Fig. 65)

NOTE: The gear pump must be replaced as a complete assembly. Individual gears, housings and thrust plates are not available separately. Disassemble gear pump for cleaning, inspection and seal replacement only.

IMPORTANT: Keep bodies, gears, flanges and thrust plates for each pump section together; do not mix parts between pump sections.

1. Plug pump ports and thoroughly clean exterior of pump with cleaning solvent. Make sure work area is clean.

2. Use a marker to make a **diagonal** line across the gear pump for assembly purposes (Fig. 66).

IMPORTANT: Use caution when clamping gear pump in a vise to avoid distorting any pump components.

3. Secure the front cover of the pump in a vise with the drive shaft pointing down.

4. Loosen the two (2) cap screws and two (2) nuts that secures pump assembly.

5. Remove pump from vise and remove fasteners.

6. Support the pump assembly and gently tap the pump case with a soft face hammer to loosen the pump sections. Be careful to not drop parts or disengage gear mesh.

IMPORTANT: Mark the relative positions of the gear teeth and the thrust plates so they can be reassembled in the same position. Do not touch the gear surfaces as residue on hands may be corrosive to gear finish.

7. Remove the thrust plates and seals from each pump section. Before removing each gear set, apply marking dye to mating teeth to retain "timing". Pump efficiency may be affected if the teeth are not installed in the same position during assembly. Keep the parts for each pump section together; do not mix parts between sections.

8. Clean all parts. Check all components for burrs, scoring, nicks and other damage.

9. Replace the entire pump assembly if parts are excessively worn or scored.

Disassembly (Fig. 65)

1. Apply clean hydraulic oil to all parts before assembling.

NOTE: Pressure seals and back-up rings fit in grooves machined into thrust plates. Body seals fit in grooves machined in body faces.

2. Assemble pump sections starting at front cover end. Apply grease or petroleum jelly to new section seals to hold them in position during gear pump assembly.

3. After pump has been assembled, tighten cap screws and nuts by hand. Rotate the drive shaft to check for binding. Protect the shaft if using a pliers.

4. Tighten the cap screws and nuts evenly in a crossing pattern to a torque of **33 ft-lb (45 N-m)**.

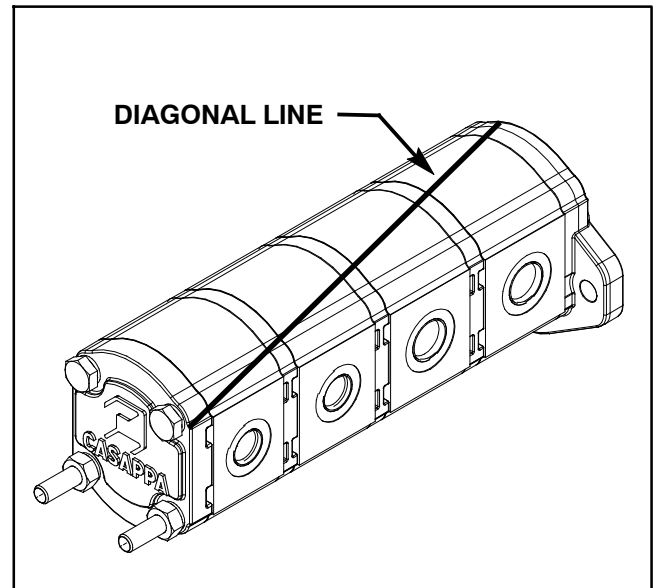

Figure 66

Front Wheel Motor

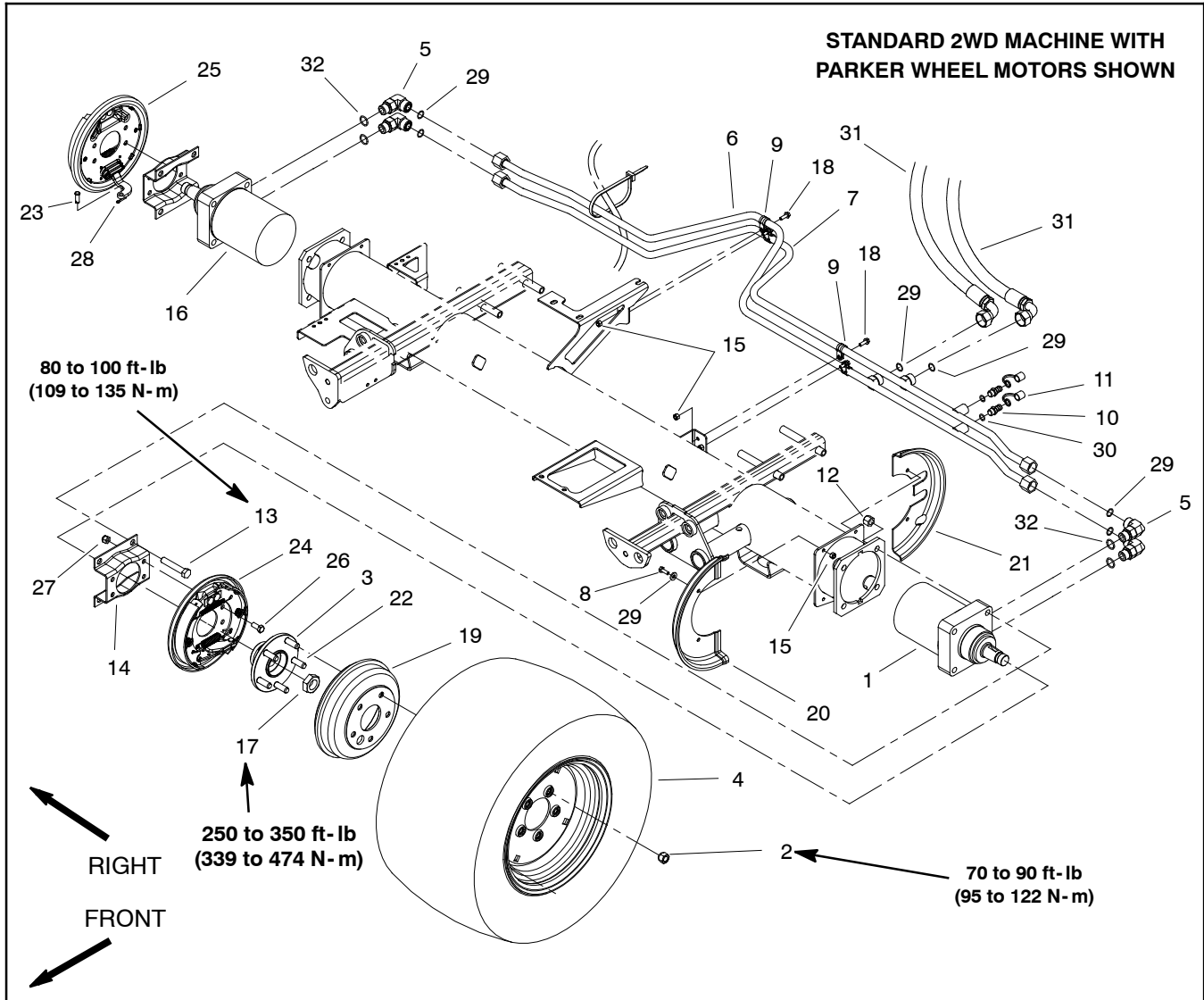

Figure 67

- | | | |
|---|---|---|
| <ul style="list-style-type: none"> 1. LH wheel motor (Parker) 2. Lug nut (5 used per wheel) 3. Hub 4. Tire and wheel assembly 5. Hydraulic fitting (4 used) 6. Hydraulic tube 7. Hydraulic tube 8. Cap screw (2 used per wheel shield) 9. R-clamp (4 used) 10. Diagnostic fitting (2 used) 11. Dust cap (2 used) | <ul style="list-style-type: none"> 12. Lock nut (4 used per wheel motor) 13. Cap screw (4 used per wheel motor) 14. Brake bracket (2 used) 15. Lock nut (2 used per wheel shield) 16. RH wheel motor 17. Lock nut (2 used) 18. Flange head screw (4 used) 19. Brake drum (2 used) 20. Front wheel shield (LH shown) 21. Rear wheel shield (LH shown) 22. Wheel stud (5 used per wheel) | <ul style="list-style-type: none"> 23. Clevis pin (2 used) 24. LH brake assembly 25. RH brake assembly 26. Cap screw (4 used per brake assy) 27. Lock nut (4 used per brake assy) 28. Cotter pin (2 used) 29. O-ring 30. O-ring 31. Hydraulic hose 32. O-ring |
|---|---|---|

NOTE: Machines produced with serial number below 311000600 were produced with Parker brand front wheel motors. Figure 67 shows the front axle assembly with Parker wheel motors. Machines with serial number above 311000600 were produced with Eaton brand front wheel motors. Figure 68 shows the front axle assembly with Eaton wheel motors. If Parker brand wheel motors were replaced for some reason, the replacement wheel motors may have been Eaton brand. Wheel motors have an identification tag on them which identifies the brand. Removal and installation of front wheel motors is very similar regardless of motor brand.

Removal

1. Park the machine on a level surface, engage parking brake, lower cutting units and stop engine. Remove key from the ignition switch.
2. Read the General Precautions for Removing and Installing Hydraulic System Components at the beginning of the Service and Repairs section of this chapter.



CAUTION

Before opening hydraulic system, operate all hydraulic controls to relieve system pressure and avoid injury from pressurized hydraulic oil. See Relieving Hydraulic System Pressure in the General Information section of this chapter.

3. Remove front wheel from machine (see Front Wheel Removal in the Service and Repairs section of Chapter 6 - Chassis).

NOTE: Clevis pin that secures brake cable to brake actuator lever is secured with cotter pin (shown in Fig. 67) or extension spring (shown in Figs. 68 and 69).

4. Remove cotter pin or spring from clevis pin that secures brake cable to brake actuator lever. Remove clevis pin and position brake cable away from brake actuator lever.

5. Remove brake drum.

6. Loosen, but do not fully remove, lock nut that secures wheel hub to wheel motor. Loosen lock nut at least two (2) turns.

IMPORTANT: DO NOT hit wheel hub, wheel hub puller or wheel motor with a hammer during wheel hub removal or installation. Hammering may cause damage to the wheel motor.

7. Use wheel hub puller (see Special Tools in this chapter) to loosen brake drum assembly from wheel motor.

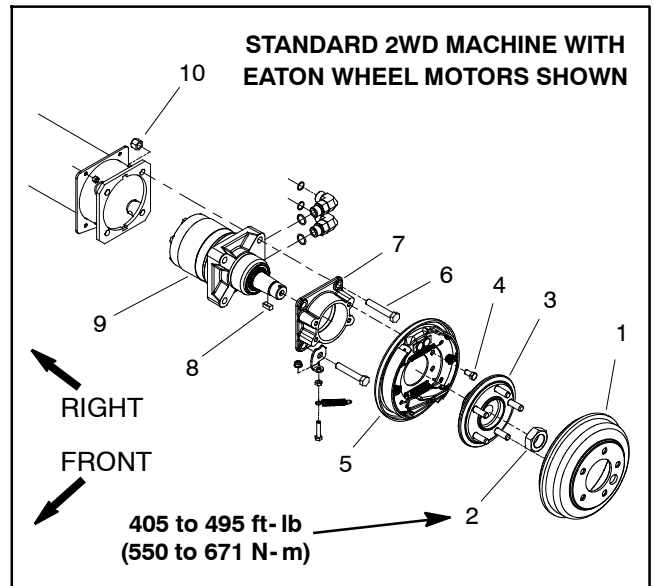

Figure 68

- | | |
|-----------------------|------------------------|
| 1. Brake drum | 6. Cap screw (4 used) |
| 2. Lock nut | 7. Brake adapter |
| 3. Wheel hub | 8. Square key |
| 4. Cap screw (4 used) | 9. Wheel motor (Eaton) |
| 5. Brake assembly | 10. Lock nut (4 used) |

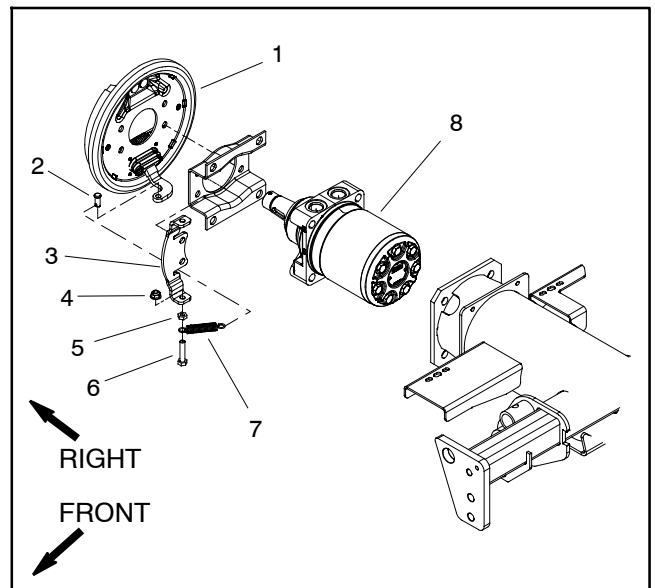

Figure 69

- | | |
|-------------------------|---------------------|
| 1. Brake assembly | 5. Jam nut |
| 2. Clevis pin | 6. Cap screw |
| 3. Brake spring bracket | 7. Extension spring |
| 4. Flange nut | 8. Wheel motor |

8. Remove lock nut and wheel hub from motor shaft. Locate and retrieve key.

9. Thoroughly clean hydraulic line ends and fittings on wheel motor to prevent hydraulic system contamination.

10. Label hydraulic connections at wheel motor for assembly purposes.

11. Disconnect hydraulic lines from fittings on wheel motor. Allow lines to drain into a suitable container.
12. Put caps or plugs on disconnected lines and fittings to prevent contamination.
13. Support wheel motor to prevent it from falling. Remove four (4) lock nuts from cap screws that secure motor and brake bracket to frame.
14. Remove four (4) cap screws, brake assembly and brake bracket from wheel motor and frame.
15. Remove wheel motor from machine.
16. If hydraulic fittings are to be removed from wheel motor, mark fitting orientation to allow correct assembly. Remove fittings from motor and discard O-rings.

Installation

1. If fittings were removed from wheel motor, lubricate and place new O-rings to fittings. Install fittings into motor ports using marks made during the removal process to properly orientate fittings (see Hydraulic Fitting Installation in the General Information section of this chapter).
2. Position wheel motor to frame. Slide brake assembly, brake bracket and four (4) cap screws onto wheel motor and frame.
3. Install and tighten four (4) lock nuts onto cap screws to secure motor and brake bracket to frame. Torque lock nuts from **80 to 100 ft-lb (109 to 135 N-m)**.
4. Thoroughly clean wheel motor shaft and wheel hub taper.
5. Install key into the wheel motor shaft keyslot. Align wheel hub with key and slide wheel hub onto motor shaft. Secure hub with lock nut.
 - A. On machines with Parker wheel motors, torque lock nut from **250 to 350 ft-lb (339 to 474 N-m)**.
 - B. On machines with Eaton wheel motors, torque lock nut from **405 to 495 ft-lb (550 to 671 N-m)**.
6. Remove caps or plugs from disconnected hydraulic lines and fittings.
7. Lubricate and position new O-rings to fittings on wheel motor. Use labels placed during the removal process to properly install hydraulic lines to wheel motor fittings.
8. Position brake cable end to brake actuator lever. Secure brake cable clevis to brake actuator lever with clevis pin and cotter pin or spring.
9. Install front wheel to machine (see Front Wheel Installation in the Service and Repairs section of Chapter 6 - Chassis). Make sure that lug nuts are torqued from **70 to 90 ft-lb (95 to 122 N-m)**.
10. Check and adjust oil level in hydraulic tank.

IMPORTANT: If a wheel motor failure occurred, refer to Traction Circuit Component Failure in the General Information section for information regarding the importance of removing contamination from the traction circuit.

11. Operate machine functions slowly until air is out of system (see Charge Hydraulic System in this section).

This page is intentionally blank.

Wheel Motor Service (Parker)

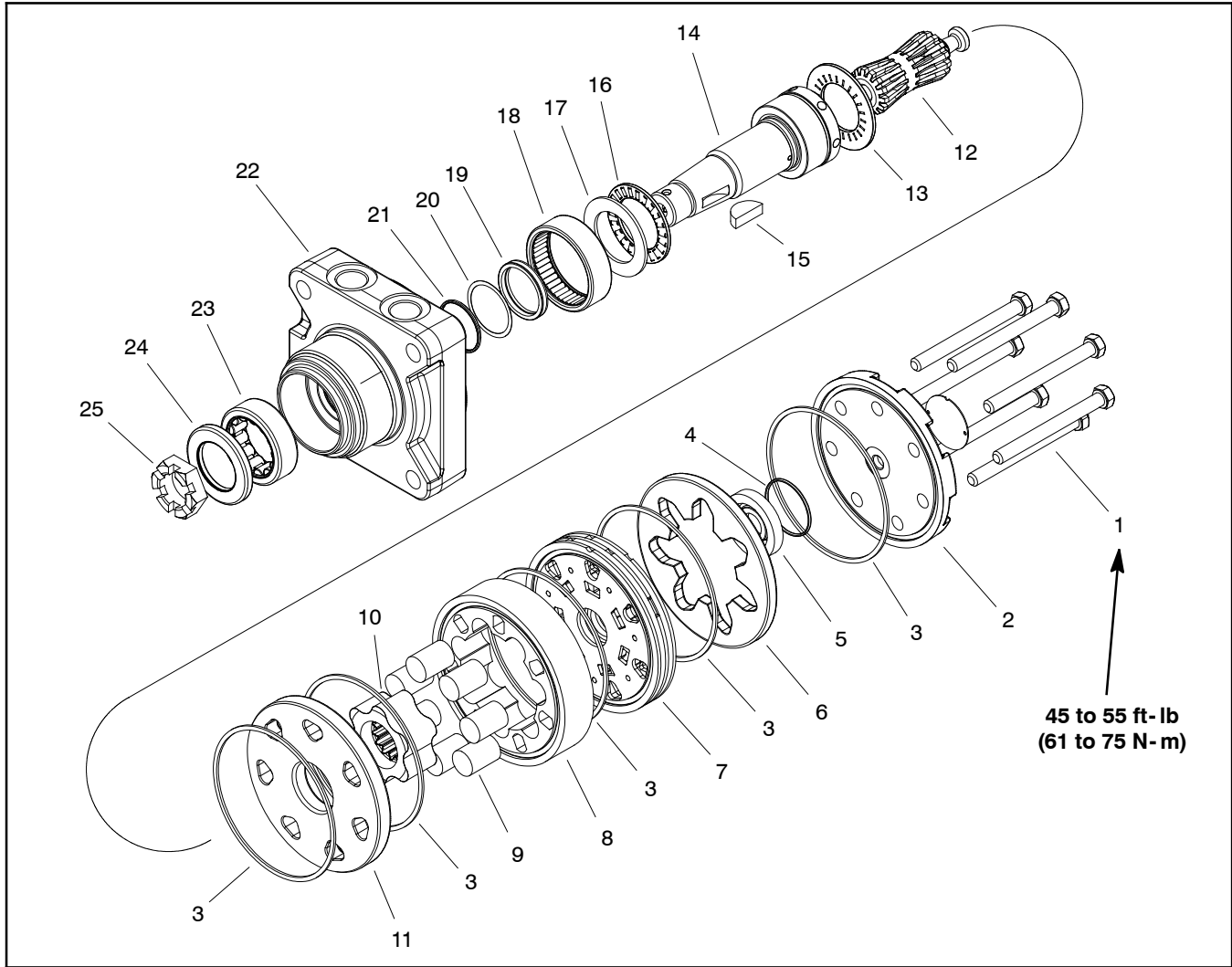

Figure 70

- 1. Cap screw (7 used)
- 2. End cover
- 3. Body seal (5 used)
- 4. Commutator ring
- 5. Commutator
- 6. Commutator ring
- 7. Manifold
- 8. Stator
- 9. Vane (7 used)

- 10. Rotor
- 11. Wear plate
- 12. Drive link
- 13. Thrust bearing
- 14. Coupling shaft
- 15. Woodruff key
- 16. Thrust bearing
- 17. Thrust washer

- 18. Inner bearing
- 19. Shaft seal
- 20. Back-up washer
- 21. Back-up ring
- 22. Housing
- 23. Outer bearing
- 24. Dirt and water seal
- 25. Lock nut

NOTE: The front wheel motors on Reelmaster 5010 machines with serial number below 311000600 are Parker Torqmotor™ TG Series. Wheel motors have an identification tag on them which identifies the brand. Right and left motors are the same basic design but the right side motors have a reverse timed manifold to allow correct rotation direction for forward and reverse. The left side wheel motors are identified with a yellow dot on the motor flange.

NOTE: On machines equipped with optional Cross-Trax™ AWD kit, the rear wheel motors are Parker Torqmotor™ TL Series.

NOTE: For Parker wheel motor repair procedures, see the Parker Torqmotor™ Service Procedure (TC, TB, TE, TJ, TF, TG, TH and TL Series) at the end of this chapter.

Front Wheel Motor Service (Eaton)

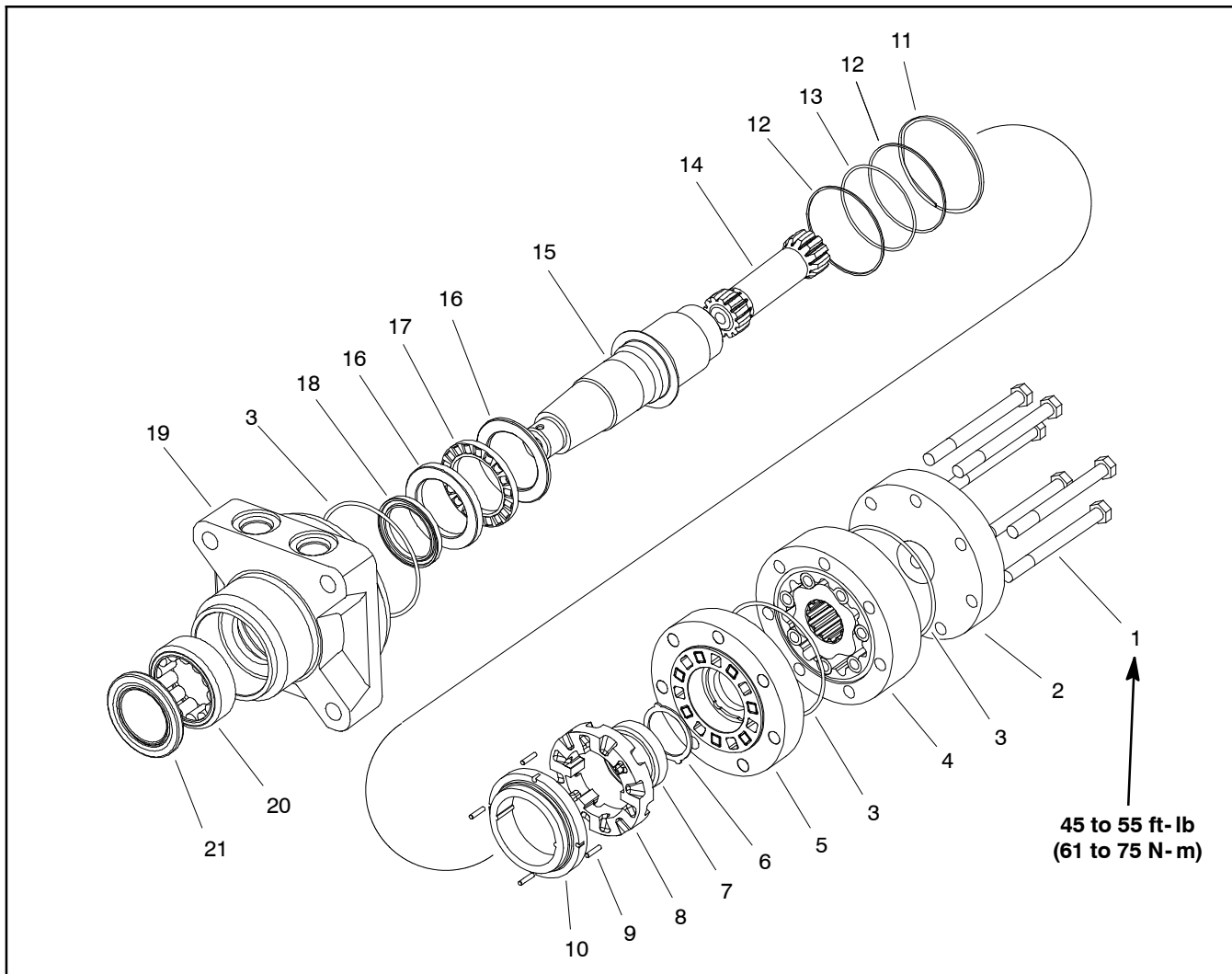

Figure 71

- 1. Cap screw (7 used)
- 2. End cap
- 3. O-ring (3 used)
- 4. Geroler assembly
- 5. Valve plate
- 6. Thrust bearing
- 7. Bearing

- 8. Valve
- 9. Dowel pin (4 used)
- 10. Balancing ring
- 11. Valve spring
- 12. Back-up ring
- 13. O-ring
- 14. Drive

- 15. Output shaft
- 16. Bearing race (2 used)
- 17. Thrust bearing
- 18. Shaft seal
- 19. Housing
- 20. Bearing
- 21. Grease seal

NOTE: Machines with serial number above 311000600 were produced with Eaton brand front wheel motors. If front wheel motors were replaced for some reason on a machine with serial number below 311000600, the replacement wheel motors may have been Eaton brand. Wheel motors have an identification tag on them which identifies the brand. Right and left motors are the same basic design but the right side motors have a reverse timed manifold to allow correct rotation direction for forward and reverse. The left side wheel motors are identified with either a machined groove or a painted yellow mark on the end of the output shaft.

NOTE: On machines equipped with optional Cross-Trax™ AWD kit, the rear wheel motors are Parker Torq-motor™ TL Series.

NOTE: For Eaton wheel motor repair procedures, see the Eaton Delta Motors Parts and Repair Manual at the end of this chapter.

IMPORTANT: If a wheel motor failure occurred, refer to Traction Circuit Component Failure in the General Information section for information regarding the importance of removing contamination from the traction circuit.

Hydraulic System

Mow Control Manifold

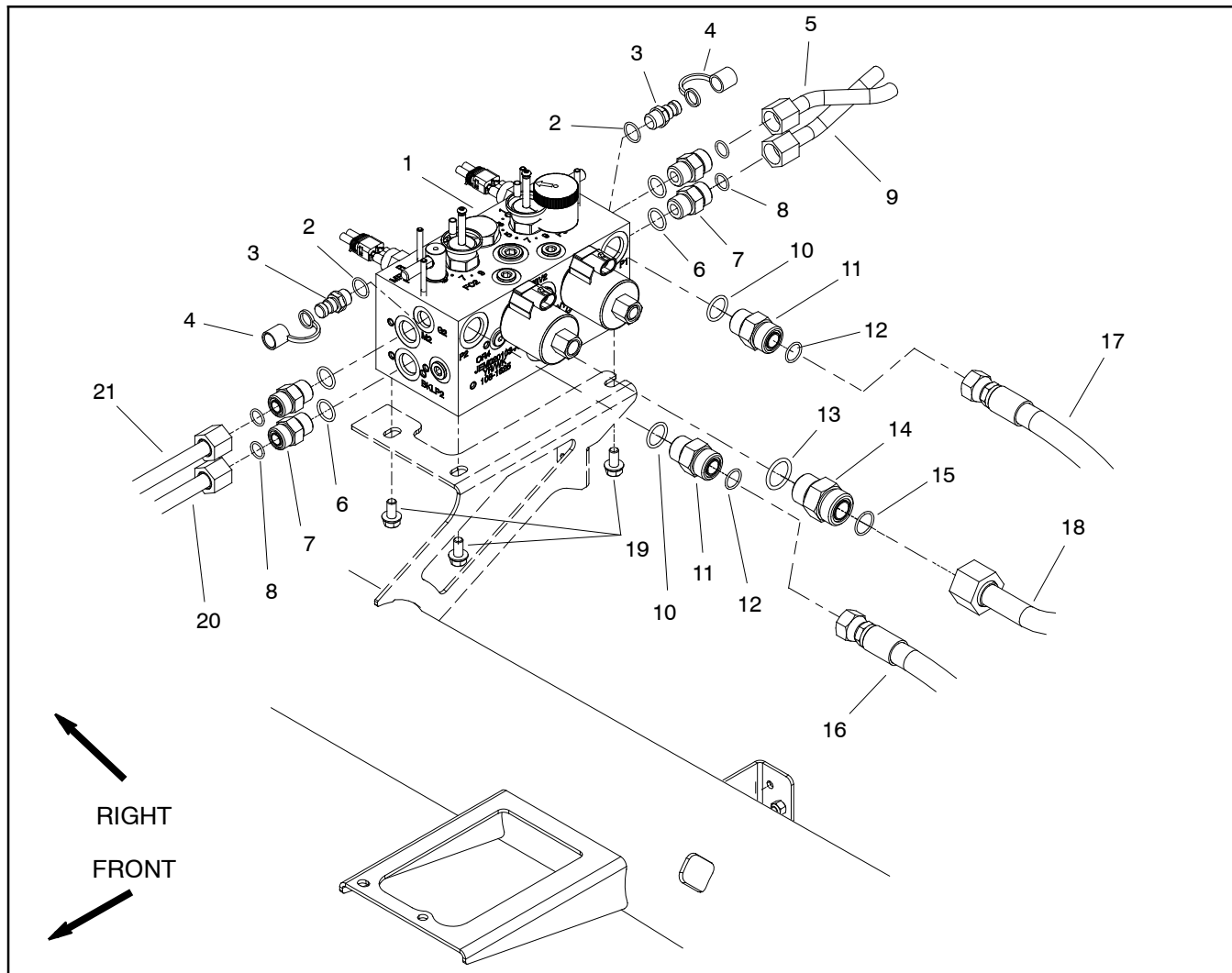

Figure 72

- | | | |
|-------------------------------|-----------------------|--------------------------------|
| 1. Mow control manifold | 8. O-ring | 15. O-ring |
| 2. O-ring | 9. Hydraulic tube | 16. Hydraulic hose |
| 3. Diagnostic fitting | 10. O-ring | 17. Hydraulic hose |
| 4. Dust cap | 11. Hydraulic fitting | 18. Hydraulic tube |
| 5. Hydraulic tube | 12. O-ring | 19. Flange head screw (3 used) |
| 6. O-ring | 13. O-ring | 20. Hydraulic tube |
| 7. Hydraulic fitting (4 used) | 14. Hydraulic fitting | 21. Hydraulic tube |

Removal (Fig. 72)

1. Park the machine on a level surface, engage parking brake, lower cutting units and stop engine. Remove key from the ignition switch.
2. Read the General Precautions for Removing and Installing Hydraulic System Components at the beginning of the Service and Repairs section of this chapter.
3. Tilt operator seat and engage seat prop to retain seat in the raised position.
4. Locate hydraulic mow control manifold.
5. Label all hydraulic and electrical connections for assembly purposes. Thoroughly clean hydraulic connections prior to loosening hydraulic lines.



6. Disconnect hydraulic hoses and lines from fittings in manifold. Allow lines to drain into a suitable container. Remove and discard O-rings from fittings.
7. Put caps or plugs on disconnected hoses and fittings to prevent contamination.
8. Unplug wire harness leads from solenoid coils and switches on manifold.

9. Remove three (3) flange head screws that secure manifold to machine frame.

10. Remove manifold block from machine.

11. If necessary, remove hydraulic fittings from manifold. Discard any removed O-rings.

Installation (Fig. 72)

1. If fittings were removed from mow control manifold, lubricate and place new O-rings to fittings. Install fittings into manifold (see Hydraulic Fitting Installation in the General Information section of this chapter).

2. Position mow control manifold to frame. Install three (3) flange head screws but do not fully tighten.

3. Remove caps and plugs from disconnected lines and fittings.

4. Lubricate and install new O-rings on manifold fittings. Connect hydraulic lines to hydraulic fittings on manifold. Properly tighten all connections (see Hydraulic Fitting Installation in the General Information section).

5. Secure hydraulic manifold to frame by tightening three (3) flange head screws.

6. Plug wire harness leads to solenoid coils and switches on manifold.

7. Lower operator seat.

8. Check oil level in hydraulic reservoir and add correct oil if necessary.

9. Follow Hydraulic System Start-up procedures (see Hydraulic System Start-up in this section).

Mow Control Manifold Service

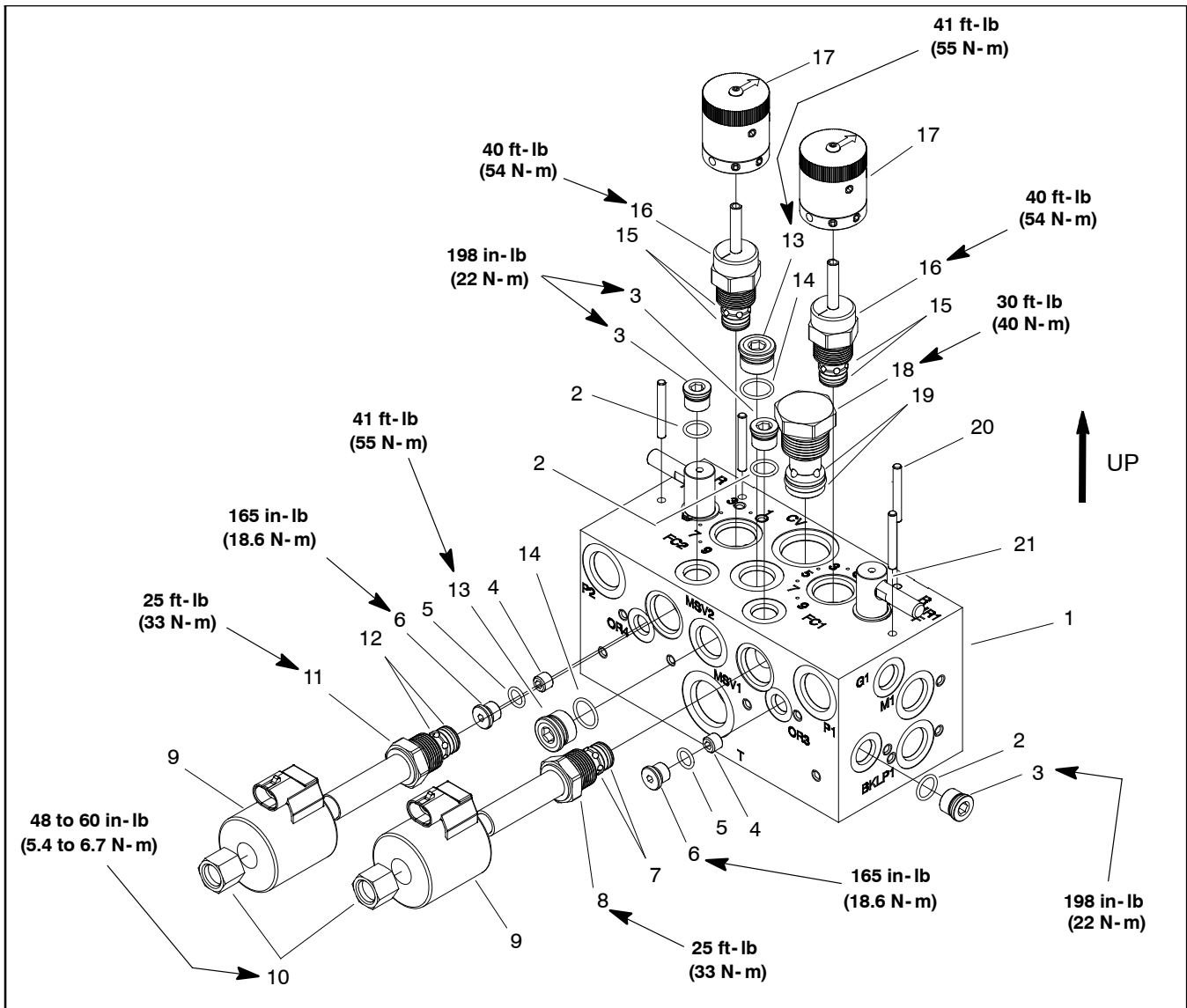

Figure 73

- | | | |
|-------------------------|--|---------------------------|
| 1. Mow control manifold | 8. Solenoid relief valve cartridge (MSV1) | 15. Seal kit |
| 2. O-ring | 9. Solenoid coil | 16. Flow control valve |
| 3. Plug (zero leak #6) | 10. Nut | 17. Rotary handle |
| 4. Orifice (0.020) | 11. Solenoid relief valve cartridge (MSV2) | 18. Check valve |
| 5. O-ring | 12. Seal kit | 19. Seal kit |
| 6. Plug (SAE #4) | 13. Plug (zero leak #8) | 20. Pin (4 used) |
| 7. Seal kit | 14. O-ring | 21. Rotary spool (2 used) |

NOTE: The ports on the control manifolds are marked for easy identification of components. Example: P1 on is the pump P1 connection port and MSV2 is the location for the solenoid relief valve MSV2 (See Hydraulic Schematics to identify the function of the hydraulic lines and cartridge valves at each port).

NOTE: The mow control manifold uses several zero leak plugs. These plugs have a tapered sealing surface on the plug head that is designed to resist vibration induced plug loosening. The zero leak plugs also have an O-ring to provide a secondary seal. If zero leak plug removal is necessary, lightly rap the plug head using a punch and hammer before using an allen wrench to remove the plug: the impact will allow plug removal with less chance of damage to the socket head of the plug. When installing plugs into the control manifold, torque plugs to the values identified in Figures 73 and 76.

Mow Control Manifold Service

1. Make sure the manifold is thoroughly cleaned before removing any cartridge valve.
2. If solenoid cartridge valve is being serviced, remove nut securing solenoid coil to the cartridge valve. Carefully slide solenoid coil off the valve.
3. If flow control cartridge valve is being serviced, remove rotary handle from valve stem (Fig. 74):

- A. Loosen two (2) set screws that secure handle cap.
- B. Remove screw and then lift handle cap from valve.
- C. Locate and retrieve detent pin, compression spring, bushing and lip seal. The sleeve bearing should stay in the cap.
- D. Loosen two (2) set screws that secure handle base to flow control valve and remove base.



CAUTION

Before opening hydraulic system, operate all hydraulic controls to relieve system pressure and avoid injury from pressurized hydraulic oil. See Relieving Hydraulic System Pressure in the General Information section of this chapter.

IMPORTANT: Use care when removing cartridge valves. Slight bending or distortion of the stem tube can cause binding and malfunction. Make sure that deep well socket fully engages the valve base.

4. Using a deep well socket, remove cartridge valve from manifold. Note correct location of O-rings, sealing rings and backup rings. Remove and discard seal kit from valve.

IMPORTANT: Before removing mow/backlap spool from mow manifold, remove backlap switch, dowel pin and ball.

5. If necessary, remove mow/backlap spool from mow manifold (Fig. 75):

- A. Remove backlap switch from mow manifold before removing mow/backlap spool (Fig. 76). Remove dowel pin and ball from manifold port after switch is removed. Remove and discard O-ring from switch.
- B. Remove lower retaining ring from mow/backlap spool. Raise mow/backlap spool to allow access to retaining ring on upper end of spool. Remove upper retaining ring.

- C. Push spool down until O-ring and back-up ring are exposed on bottom of mow manifold. Remove lower O-ring and back-up ring from spool.
- D. Pull spool up and out of mow manifold. Remove O-rings and back-up ring from spool.
- E. Discard removed O-rings and back-up rings.

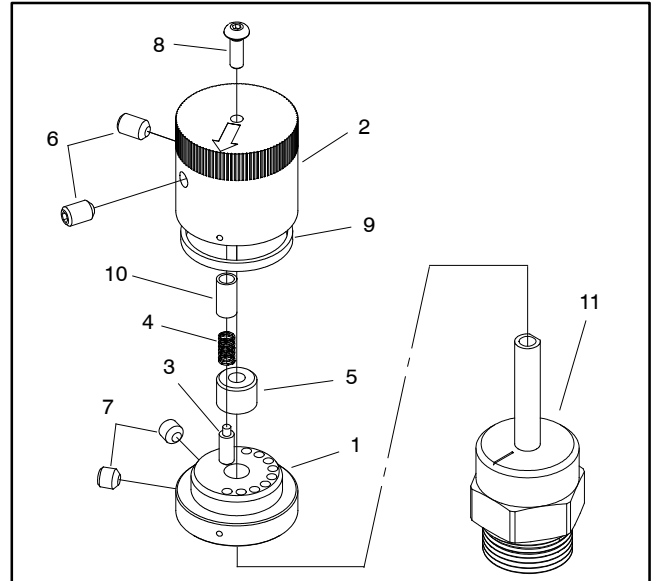

Figure 74

- | | |
|-----------------------|------------------------|
| 1. Handle base | 7. Set screw (2 used) |
| 2. Handle cap | 8. Screw |
| 3. Detent pin | 9. Lip seal |
| 4. Compression spring | 10. Sleeve bearing |
| 5. Bushing | 11. Flow control valve |
| 6. Set screw (2 used) | |

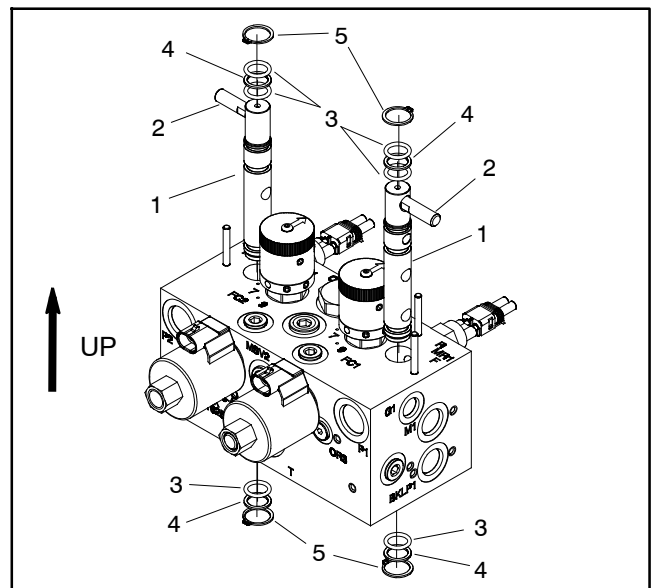

Figure 75

- | | |
|----------------------|-------------------|
| 1. Mow/backlap spool | 4. Back-up ring |
| 2. Handle | 5. Retaining ring |
| 3. O-ring | |

Hydraulic System

6. Visually inspect the manifold port for damage to the sealing surfaces, damaged threads and contamination.

7. Visually inspect cartridge valve for damaged sealing surfaces and contamination.

A. Contamination may cause valves to stick or hang up. Contamination can become lodged in small valve orifices or seal areas causing valve malfunction.

B. If valve sealing surfaces appear pitted or damaged, the hydraulic system may be overheating or there may be water in the system.

E. If handle was removed from spool, position spool so handle location of spool is between stop pins. Apply Loctite 603 Retaining Compound (or equivalent) to threads on handle and install handle into spool.

F. Place ball and dowel pin in backlap switch manifold port (Fig. 76). Install new O-ring onto backlap switch. Thread backlap switch into port and torque **15 ft-lb (20 N-m)**.

10. Reinstall cartridge valve into manifold:

A. Lubricate new seal kit components with clean hydraulic oil and install on valve. The O-rings, sealing rings and backup rings must be arranged properly on the cartridge valve for proper operation and sealing.

IMPORTANT: Use care when installing cartridge valves. Slight bending or distortion of the stem tube can cause binding and malfunction. Make sure that deep well socket fully engages the valve base.

B. Lubricate threads of cartridge valve with clean hydraulic oil. Thread cartridge valve carefully into correct manifold port. The valve should go in easily without binding.

C. Torque cartridge valve using a deep well socket to values identified in Figures 73 and 76.

8. Clean cartridge valve by submerging valve in clean mineral spirits to flush out contamination. Particles as fine as talcum powder can affect the operation of high pressure hydraulic valves. If cartridge design allows, use a wood or plastic probe to push the internal spool in and out 20 to 30 times to flush out contamination. Be extremely careful not to damage cartridge. Use compressed air for cleaning.

9. If mow/backlap spool was removed from mow manifold, install spool (Fig. 75):

A. Install O-rings and back-up ring to upper grooves on spool. Apply a light coating of grease to O-rings.

B. Carefully push spool down into mow manifold port until lower O-ring and back-up ring groove is exposed on bottom of manifold. Install lower O-ring and back-up ring to spool. Apply a light coating of grease to O-ring.

C. Carefully raise mow/backlap spool until upper retaining ring groove on spool is exposed on top of manifold. Install upper retaining ring.

D. Push mow/backlap spool down and install lower retaining ring to spool.

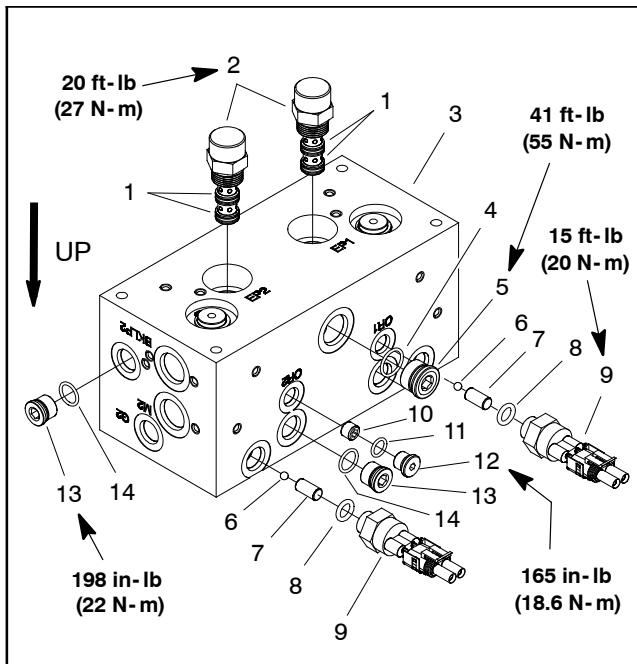

Figure 76

- | | |
|-------------------------|-------------------------|
| 1. Seal kit | 8. O-ring |
| 2. Logic cartridge | 9. Backlap switch |
| 3. Mow control manifold | 10. Orifice (0.055) |
| 4. O-ring | 11. O-ring |
| 5. Plug (zero leak #8) | 12. Plug (SAE #4) |
| 6. Ball | 13. Plug (zero leak #8) |
| 7. Dowel pin | 14. O-ring |

11. If solenoid coil was removed:

- A. Carefully install coil onto the cartridge valve.
- B. Install nut and torque nut to **48 to 60 in-lb (5.4 to 6.7 N-m)**.

12. If flow control cartridge valve was removed, install rotary handle to valve stem (Fig. 74):

- A. Place handle base on flow control valve and position alignment mark on base with number 1 on manifold. Secure base with two (2) set screws. Apply a light coating of grease to chamfer on top of base to ease seal installation.
- B. Make sure that sleeve bearing is in handle cap. If necessary, press sleeve bearing into cap. Install lip seal on cap with seal lip facing down.
- C. Place bushing onto cartridge valve stem. Use a small amount of grease to keep bushing toward the top of the valve stem.

D. Place compression spring and detent pin into handle cap. Use a small amount of grease to hold detent pin in place.

E. Make sure that flow control cartridge is closed by rotating valve stem fully clockwise. During handle installation, **DO NOT** rotate valve stem or speed adjustment will be incorrect.

F. Press handle cap onto valve stem with arrow on cap pointing to number 9 on manifold. Make sure that detent pin and spring stay positioned in cap.

G. While pressing on the cap to keep the lip seal in place, rotate cap in a clockwise direction until the arrow on the cap aligns with number 1 on the manifold. By rotating the cap clockwise, the valve will remain closed. Install screw to retain cap.

H. Make sure that alignment marks on cap and base are in line and that arrow on cap is pointing to number 1 on manifold. Tighten two (2) set screws to secure handle cap.

Lift Control Manifold

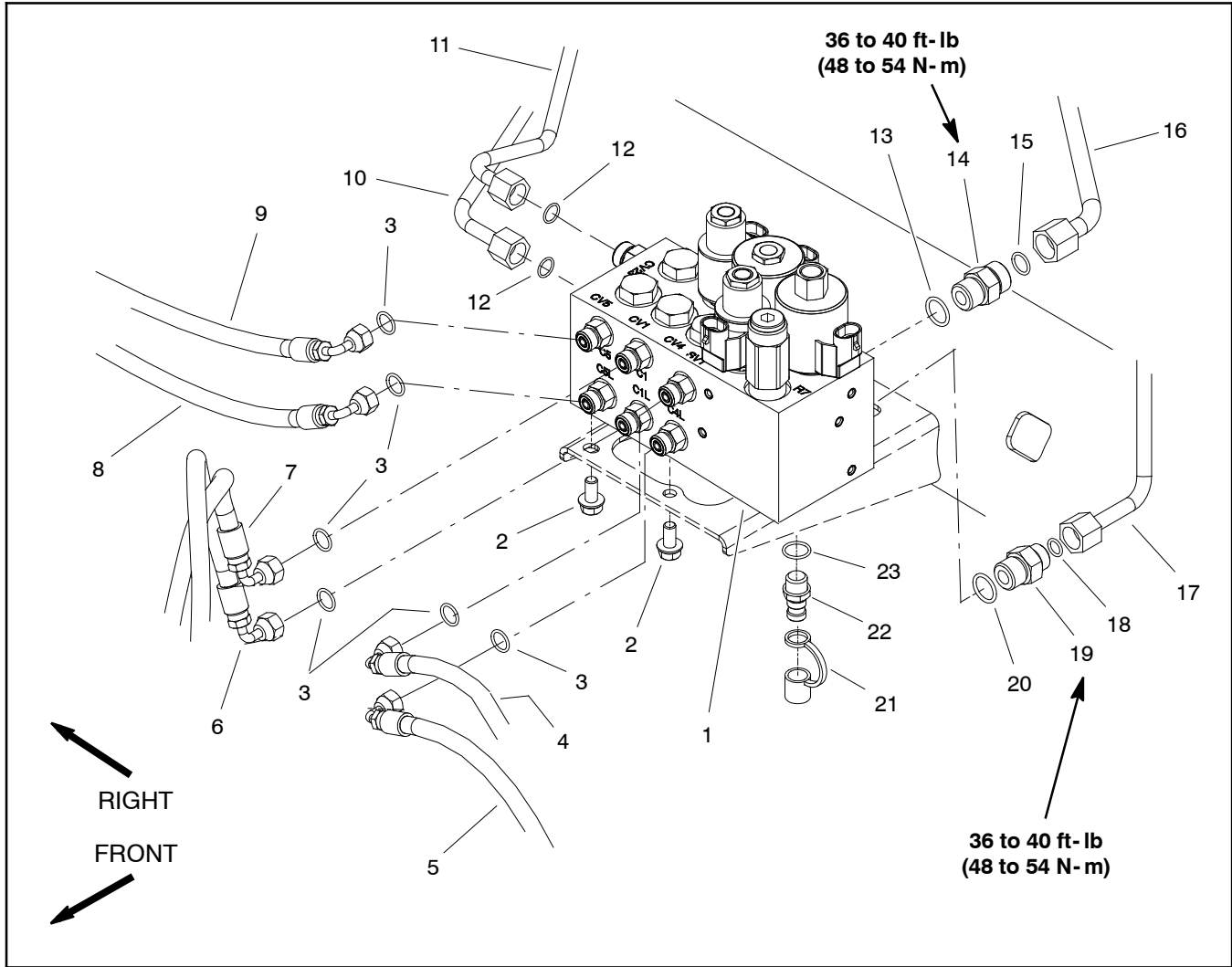

Figure 77

- 1. Lift control manifold
- 2. Flange head screw
- 3. O-ring
- 4. Hydraulic hose
- 5. Hydraulic hose
- 6. Hydraulic hose
- 7. Hydraulic hose
- 8. Hydraulic hose

- 9. Hydraulic hose
- 10. Hydraulic tube
- 11. Hydraulic tube
- 12. O-ring
- 13. O-ring
- 14. Hydraulic fitting
- 15. O-ring
- 16. Hydraulic tube

- 17. Hydraulic tube
- 18. O-ring
- 19. Hydraulic fitting
- 20. O-ring
- 21. Dust cap
- 22. Diagnostic fitting
- 23. O-ring

Removal (Fig. 77)

1. Park the machine on a level surface, engage parking brake, lower cutting units and stop engine. Remove key from the ignition switch.
2. Read the General Precautions for Removing and Installing Hydraulic System Components at the beginning of the Service and Repairs section of this chapter.
3. Locate hydraulic lift control manifold that is attached to frame bracket under the front platform.
4. Label all hydraulic connections for assembly purposes. Thoroughly clean hydraulic connections prior to loosening hydraulic lines.



CAUTION

Before opening hydraulic system, operate all hydraulic controls to relieve system pressure and avoid injury from pressurized hydraulic oil. See Relieving Hydraulic System Pressure in the General Information section of this chapter.

5. Disconnect hydraulic hoses and lines from fittings in manifold. Allow lines to drain into a suitable container. Remove and discard O-rings.
6. Put caps or plugs on disconnected lines and fittings to prevent contamination.
7. Label all solenoid coil wire harness leads for assembly purposes. Unplug wire harness leads from solenoid coils on manifold.
8. Remove two (2) flange head screws that secure manifold to machine frame.
9. Remove lift control manifold from machine.

IMPORTANT: A flow control orifice is placed beneath several hydraulic fittings on the lift control manifold (Fig. 78). The lift manifold uses three (3) different orifice sizes. If fittings are removed from manifold and an orifice is in the manifold port, make sure to remove orifice and label its position for assembly purposes.

10. If necessary, remove hydraulic fittings from manifold. Discard any removed O-rings. Locate, retrieve and label orifice from manifold ports (if equipped).

Installation (Fig. 77)

1. If fittings were removed from manifold:
 - A. Lubricate new O-rings with clean hydraulic oil. Install lubricated O-rings on fittings.

IMPORTANT: When installing orifice in manifold (Fig. 78), make sure that orifice is flat in the base of the fitting cavity. Manifold damage is possible if the orifice is cocked in the cavity.

B. For manifold ports with orifice, place correct orifice in port with the orifice slot facing out.

C. Install fittings into manifold. Torque fittings to torque values identified in Figures 77 and 78.

2. Position lift control manifold to frame. Install two (2) flange head screws but do not fully tighten.
3. Remove caps and plugs from disconnected lines and fittings.
4. Lubricate and install new O-ring(s) on manifold fittings. Connect hydraulic lines to hydraulic manifold fittings. Properly tighten all connections (see Hydraulic Fitting Installation in the General Information section).
5. Secure hydraulic manifold to frame by tightening two (2) flange head screws.
6. Connect wire harness leads to solenoid coils on manifold using labels placed during removal.
7. Check oil level in hydraulic reservoir and add correct oil if necessary.
8. Follow Hydraulic System Start-up procedures (see Hydraulic System Start-up in this section).

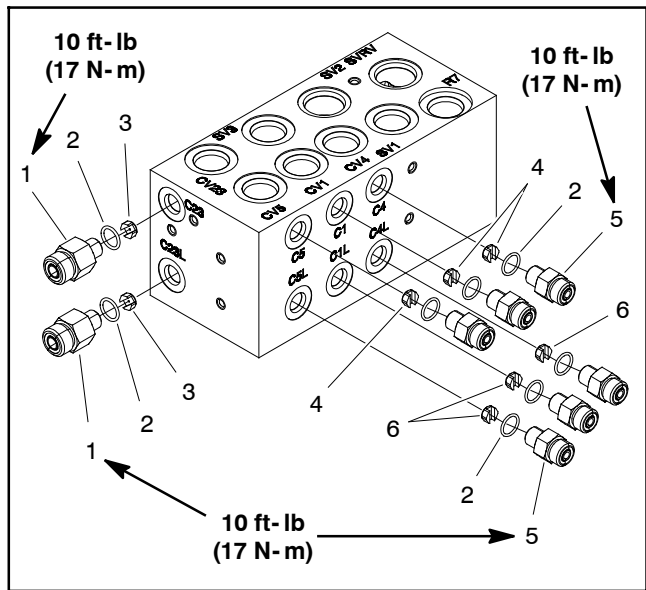

Figure 78

- | | |
|---------------------|---------------------|
| 1. Fitting (2 used) | 4. Orifice (0.028) |
| 2. O-ring | 5. Fitting (6 used) |
| 3. Orifice (0.046) | 6. Orifice (0.055) |

Lift Control Manifold Service

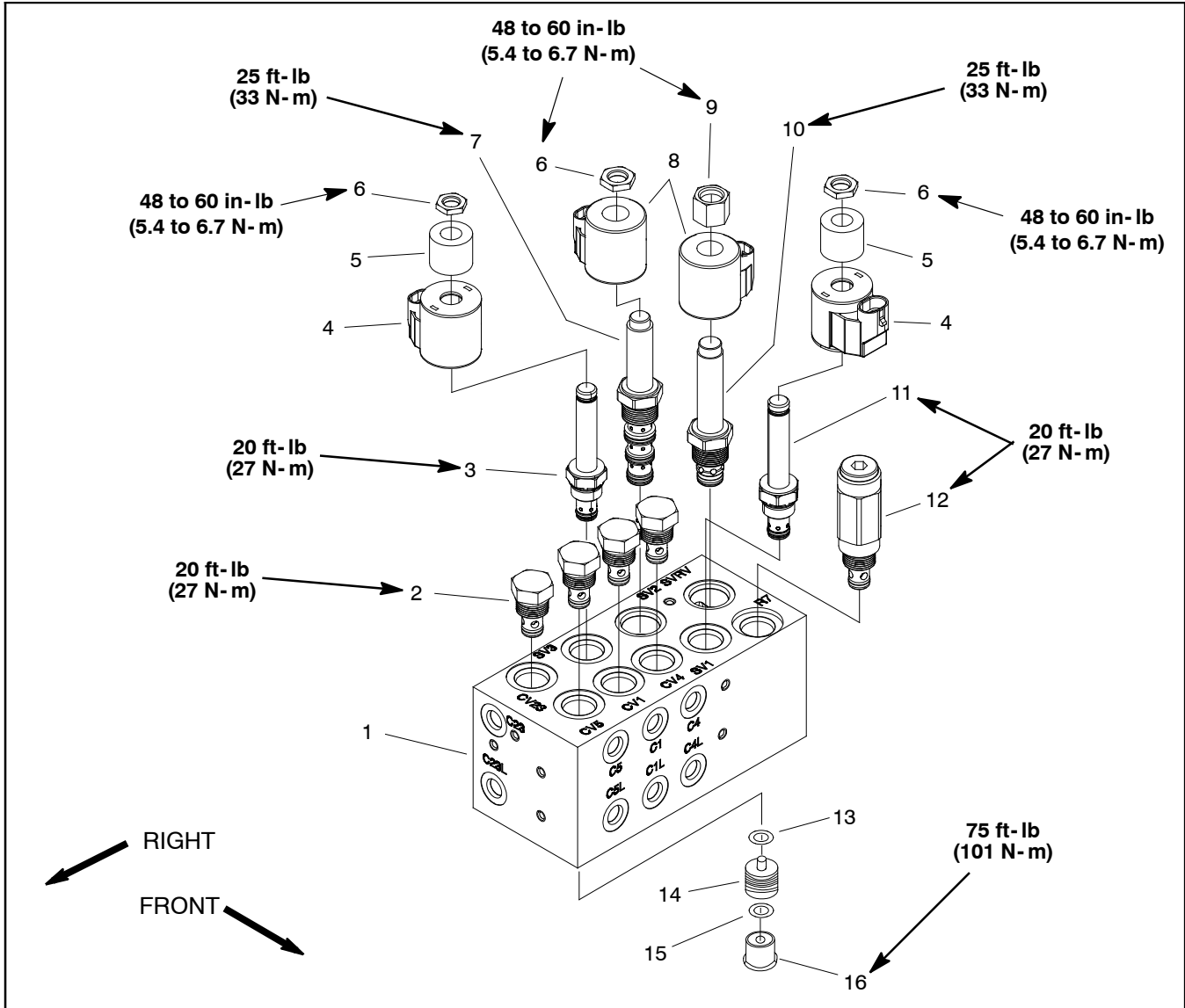

Figure 79

- | | | |
|--------------------------|----------------------------------|---------------------------|
| 1. Lift control manifold | 7. Solenoid valve (SV2) | 12. Relief valve (R7) |
| 2. Check valve (4 used) | 8. Solenoid coil | 13. O-ring |
| 3. Solenoid valve (SV3) | 9. Nut | 14. Pilot piston (4 used) |
| 4. Solenoid coil | 10. Solenoid relief valve (SVRV) | 15. O-ring |
| 5. Solenoid coil spacer | 11. Solenoid valve (SV1) | 16. Hex plug (4 used) |
| 6. Nut | | |

NOTE: The ports on the lift control manifold are marked for easy identification of components. Example: P4 is the gear pump P4 connection port and SV2 is the location for solenoid valve SV2. (See Hydraulic Schematics to identify the function of the hydraulic lines and cartridge valves at each port location).

For lift control manifold service procedures, see Mow Control Manifold Service in this section. Refer to Figure 79 for cartridge valve installation torque. Refer to Figures 79 and 80 for hydraulic fitting installation torque values.

NOTE: Solenoid valves SV1 and SV2 on the lift control manifold use a coil spacer between the solenoid coil and nut.

NOTE: Adjustment of Relief Valve (R7) is NOT recommended.

IMPORTANT: A flow control orifice is placed beneath several of the hydraulic fittings on the lift control manifold (Fig. 80). The lift manifold uses three (3) different orifice sizes. If a fitting is removed from the lift control manifold and an orifice is in the manifold port, make sure to remove orifice and label its position for assembly purposes.

IMPORTANT: When installing orifice in manifold (Fig. 80), make sure that orifice is flat in the base of the fitting cavity. Manifold damage is possible if the orifice is cocked in the cavity.

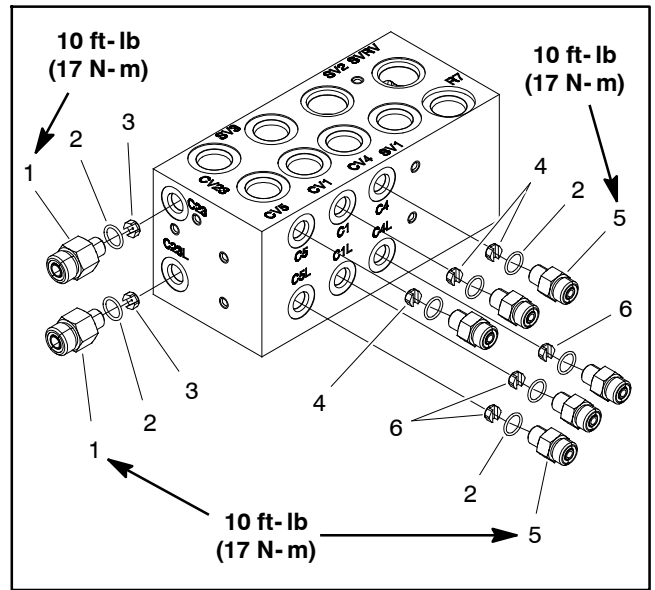

Figure 80

- | | |
|---------------------|---------------------|
| 1. Fitting (2 used) | 4. Orifice (0.028) |
| 2. O-ring | 5. Fitting (6 used) |
| 3. Orifice (0.046) | 6. Orifice (0.055) |

CrossTrax™ AWD (Optional Kit) Manifold

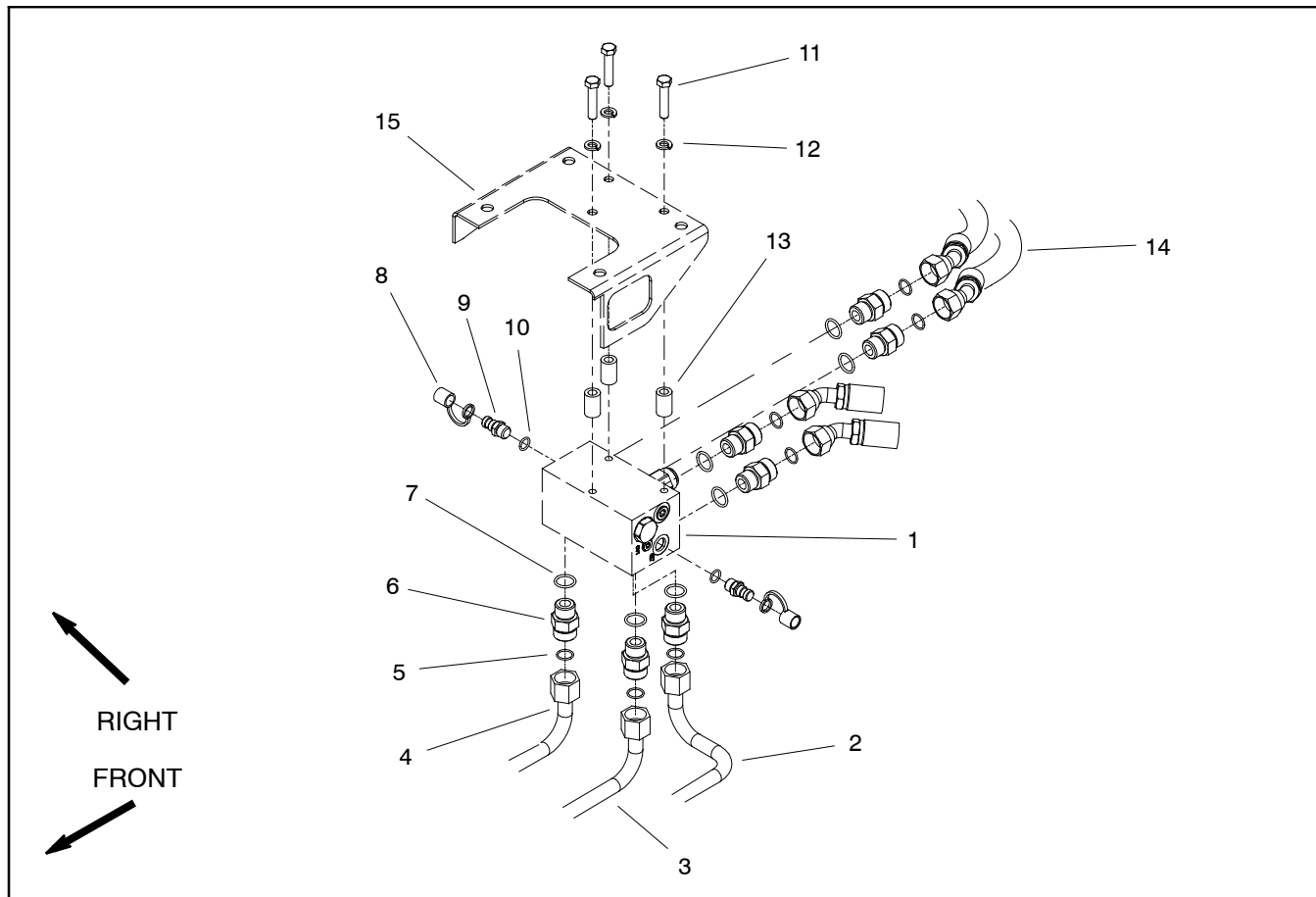

Figure 81

- | | | |
|-------------------|--------------------------------|-----------------------------|
| 1. AWD manifold | 6. Hydraulic fitting (7 used) | 11. Cap screw (3 used) |
| 2. Hydraulic tube | 7. O-ring | 12. Lock washer (3 used) |
| 3. Hydraulic tube | 8. Dust cap (2 used) | 13. Spacer (3 used) |
| 4. Hydraulic tube | 9. Diagnostic fitting (2 used) | 14. Hydraulic hose (4 used) |
| 5. O-ring | 10. O-ring | 15. Frame bracket |

Removal (Fig. 81)

1. Park the machine on a level surface, engage parking brake, lower cutting units and stop engine. Remove key from the ignition switch.
2. Read the General Precautions for Removing and Installing Hydraulic System Components at the beginning of the Service and Repairs section of this chapter.
3. Locate CrossTrax™ AWD manifold that is attached to bracket at rear of frame.
4. Label all hydraulic connections for assembly purposes. Thoroughly clean hydraulic connections prior to loosening hydraulic lines.



CAUTION

Before opening hydraulic system, operate all hydraulic controls to relieve system pressure and avoid injury from pressurized hydraulic oil. See Relieving Hydraulic System Pressure in the General Information section of this chapter.

5. Disconnect hydraulic hoses and tubes from fittings in manifold. Allow lines to drain into a suitable container. Remove and discard O-rings.

6. Put caps or plugs on disconnected lines and fittings to prevent contamination.
7. Support manifold to prevent it from falling. Remove three (3) cap screws and lock washers that secure manifold to machine frame. Locate and retrieve three (3) spacers from between bracket and manifold.
8. Remove AWD manifold from machine.
9. If necessary, remove hydraulic fittings from manifold. Discard any removed O-rings.

Installation (Fig. 81)

1. If fittings were removed from AWD manifold, lubricate and place new O-rings to fittings. Install fittings into manifold (see Hydraulic Fitting Installation in the General Information section of this chapter).

2. Position manifold and three (3) spacers to frame bracket. Install three (3) lock washers and cap screws but do not fully tighten.
3. Remove caps and plugs from disconnected lines and fittings.
4. Lubricate and install new O-ring(s) on manifold fittings. Connect hydraulic lines to hydraulic manifold fittings. Properly tighten all connections (see Hydraulic Fitting Installation in the General Information section).
5. Secure AWD manifold to frame by tightening three (3) cap screws.
6. Check oil level in hydraulic reservoir and add correct oil if necessary.
7. Follow Hydraulic System Start-up procedures (see Hydraulic System Start-up in this section).

CrossTrax™ AWD (Optional Kit) Manifold Service

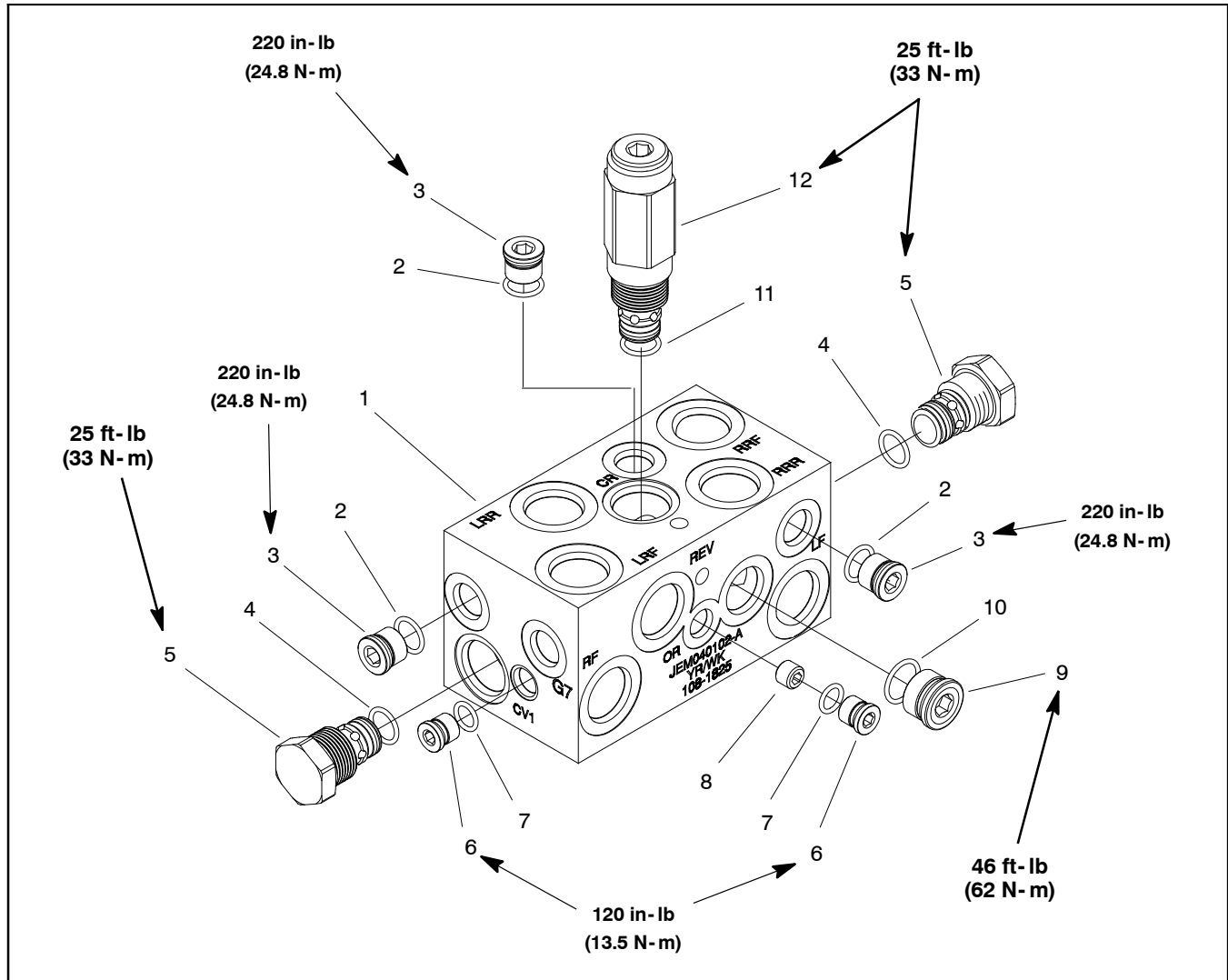

Figure 82

- | | | |
|------------------|-------------------|---------------------------------|
| 1. AWD manifold | 5. Check valve | 9. Plug (NWD #8) |
| 2. O-ring | 6. Plug (NWD #4) | 10. O-ring |
| 3. Plug (NWD #6) | 7. O-ring | 11. Seal kit |
| 4. Seal kit | 8. Orifice (.040) | 12. Bi-Directional relief valve |

For AWD control manifold service procedures, see Mow Control Manifold Service in this section. Refer to Figure 82 for cartridge valve installation torque.

NOTE: Adjustment of Bi-Directional Relief Valve is NOT recommended.

This page is intentionally blank.

Cutting Reel Motor

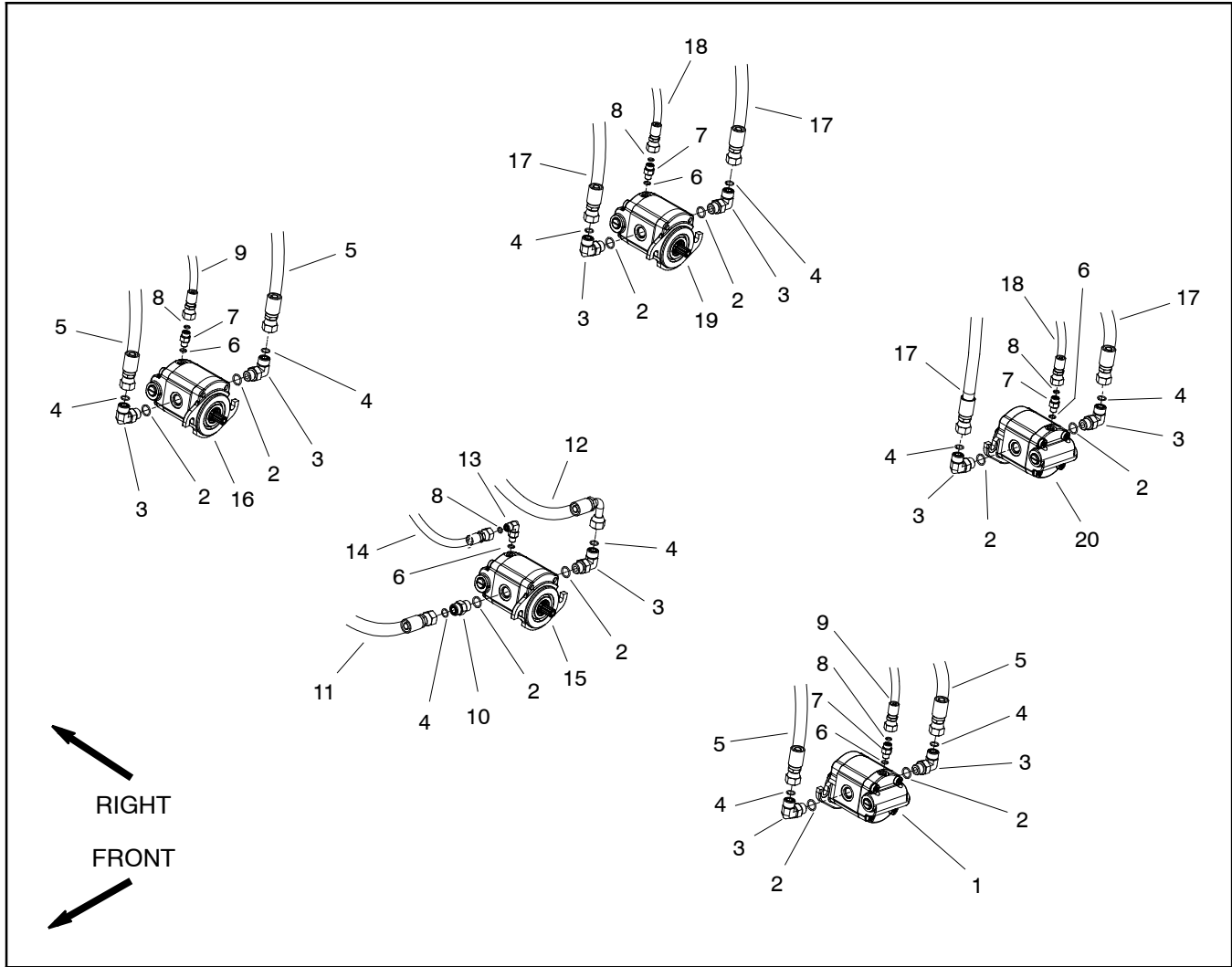

Figure 83

- | | | |
|------------------------------|---------------------------|-------------------------------|
| 1. Hydraulic reel motor (#4) | 8. O-ring | 15. Hydraulic reel motor (#1) |
| 2. O-ring | 9. Hydraulic hose | 16. Hydraulic reel motor (#5) |
| 3. 90° hydraulic fitting | 10. Hydraulic fitting | 17. Hydraulic hose |
| 4. O-ring | 11. Hydraulic hose | 18. Hydraulic hose |
| 5. Hydraulic hose | 12. Hydraulic hose | 19. Hydraulic reel motor (#3) |
| 6. O-ring | 13. 90° hydraulic fitting | 20. Hydraulic reel motor (#2) |
| 7. Hydraulic fitting | 14. Hydraulic hose | |

Removal (Fig. 83)

1. Park the machine on a level surface, engage parking brake, lower cutting units and stop engine. Remove key from the ignition switch.

2. Read the General Precautions for Removing and Installing Hydraulic System Components at the beginning of the Service and Repairs section of this chapter.

3. Label all hydraulic connections for assembly purposes. Thoroughly clean hydraulic connections prior to loosening hydraulic lines from reel motor.

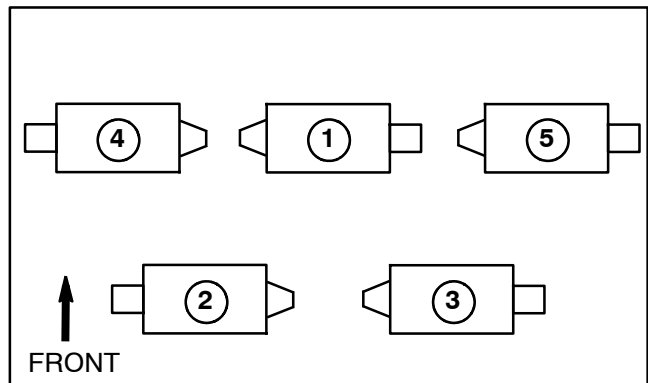

Figure 84



CAUTION

Before opening hydraulic system, operate all hydraulic controls to relieve system pressure and avoid injury from pressurized hydraulic oil. See Relieving Hydraulic System Pressure in the General Information section of this chapter.

4. Disconnect hydraulic hoses from fittings in reel motor. Allow lines to drain into a suitable container. Remove and discard O- rings.
5. Put caps or plugs on disconnected hoses and fittings to prevent contamination.
6. Remove reel motor from cutting unit (see Hydraulic Reel Motor Removal in the Service and Repairs section of Chapter 7 - Cutting Units).
7. If hydraulic fittings are to be removed from motor, mark fitting orientation to allow correct assembly. Remove fittings from motor and discard O- rings.

Installation (Fig. 83)

1. If hydraulic fittings were removed from motor, lubricate new O- rings, position O- rings to fittings and install fittings into motor ports (see Hydraulic Fitting Installation in the General Information section of this chapter). Make sure that fittings are orientated correctly.
2. Install reel motor to cutting unit (see Hydraulic Reel Motor Installation in the Service and Repairs section of Chapter 7 - Cutting Units).
3. Remove caps or plugs from fittings and hoses.

IMPORTANT: When installing the hydraulic hoses, make sure that hydraulic hoses are straight (not twisted) before tightening the hoses to the motor fittings.

4. Lubricate and install new O- rings on motor fittings. Correctly connect hydraulic hoses to the motor using labels placed during removal procedure.
5. Check oil level in hydraulic reservoir and add correct oil if necessary.
6. Follow Hydraulic System Start-up procedures (see Hydraulic System Start-up in this section).

Cutting Reel Motor Service (Bosch and Sauer- Danfoss)

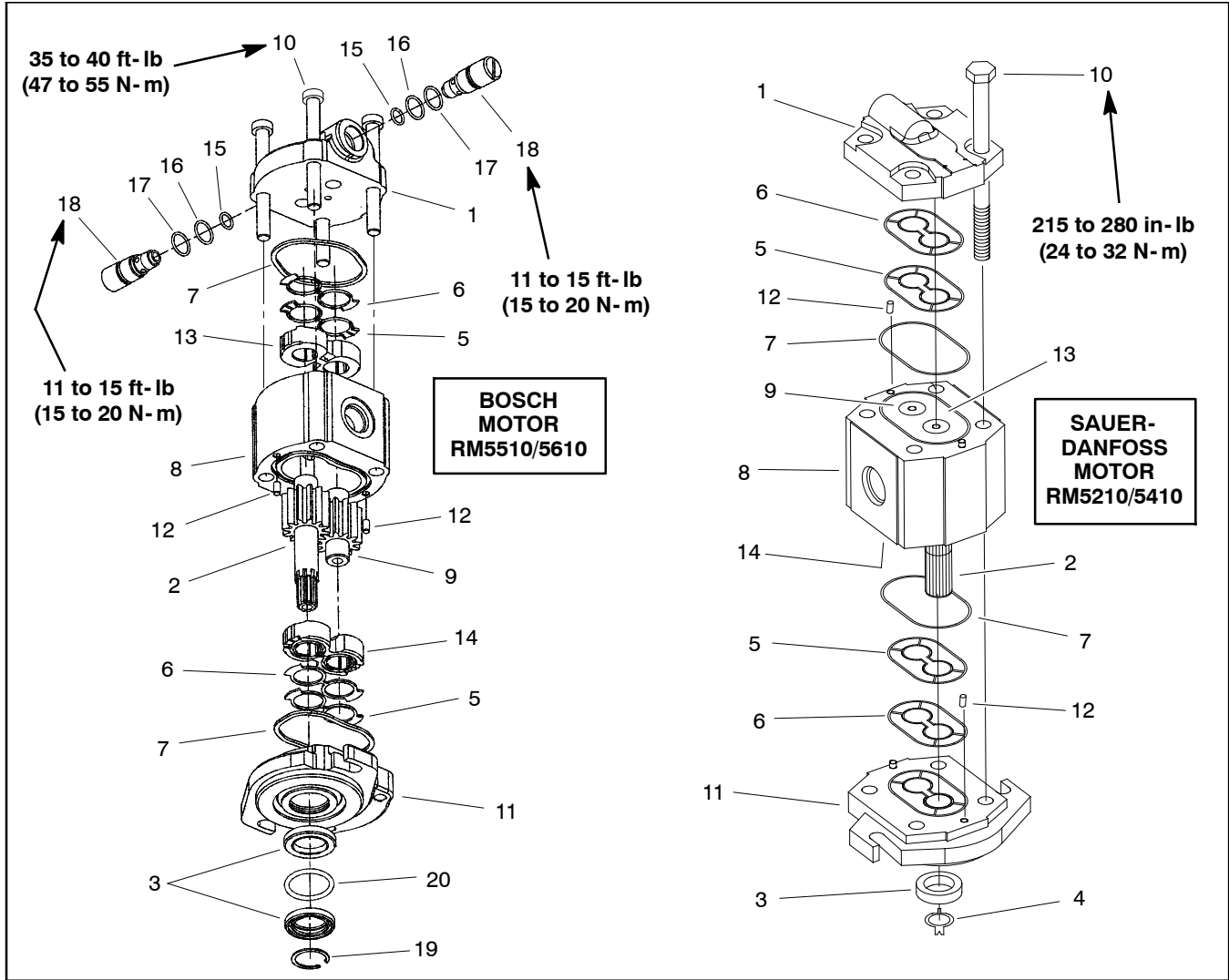

Figure 85

- | | | |
|------------------|-------------------------|----------------------|
| 1. Rear cover | 8. Body | 15. O-ring |
| 2. Drive gear | 9. Idler gear | 16. O-ring |
| 3. Seal | 10. Cap screw (4 used) | 17. Back-up ring |
| 4. Tab washer | 11. Front flange | 18. Relief cartridge |
| 5. Pressure seal | 12. Dowel pin | 19. Retaining ring |
| 6. Back-up ring | 13. Rear bearing block | 20. Washer |
| 7. O-ring | 14. Front bearing block | |

NOTE: Sauer- Danfoss cutting reel motors are used on Reelmaster 5210 and 5410 machines. Bosch reel motors are used on Reelmaster 5510 and 5610 machines. The motors used on Reelmaster 5510 and 5610 machines have two (2) cross-over relief valves in the rear cover. Service procedures for both types of motors are the same.

Disassembly (Fig. 85)

1. Plug motor ports and clean the outside of the motor thoroughly. After cleaning, remove plugs and drain any oil out of the motor.

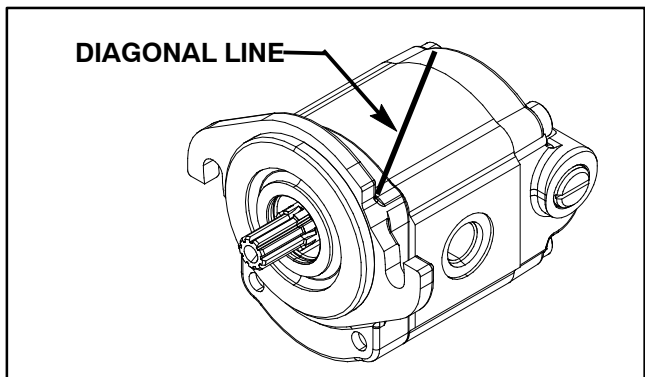

Figure 86

2. Use a marker to make a **diagonal** line across the front flange, body and rear cover for assembly purposes (Fig. 86).

IMPORTANT: Avoid using excessive clamping pressure on the motor flange to prevent damage.

3. Clamp front flange of motor in a vise with the shaft end down. Use of a vise with soft jaws is recommended.

4. Loosen cap screws that secure rear cover.

5. Remove motor from vise and remove cap screws.

6. Remove front flange from the body, then remove rear cover. Locate and remove dowel pins from body.

IMPORTANT: Mark the relative positions of the gear teeth and the bearing blocks so they can be re-assembled in the same position. Do not touch the gear surfaces as residue on hands may be corrosive to gear finish.

7. Place motor on its side and push on the rear bearing block to remove bearing block and gear set (Fig. 87).

NOTE: Pressure seals and back-up rings in Sauer-Danfoss motors fit in grooves machined into front and rear cover (Fig. 88). Pressure seals and back-up rings in Bosch motors fit in grooves machined into bearing blocks.

8. Carefully remove and discard O-rings, pressure seals and back-up rings from motor. Do not cause any damage to the machined grooves during the removal process.

IMPORTANT: Make sure not to damage the counter bore when removing the shaft seal from the front plate.

9. Position front flange with seal side up. Remove seal retainer and shaft seal(s).

10. On Bosch motor, remove relief valves from rear cover. Discard sealing washers.

Inspection

1. Remove any nicks and burrs from all motor components with emery cloth.

	CAUTION
<p>Use eye protection such as goggles when using compressed air.</p>	

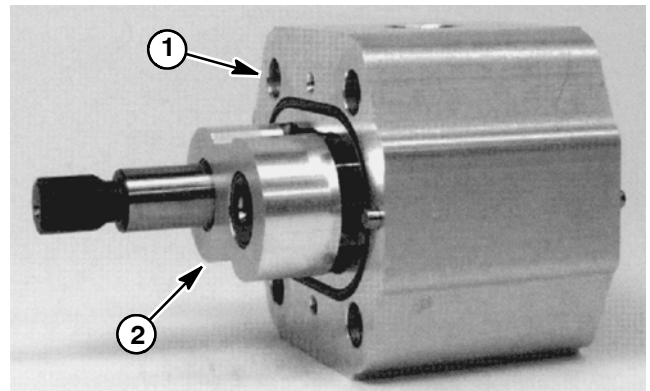

Figure 87

1. Motor body

2. Bearing block & gear set

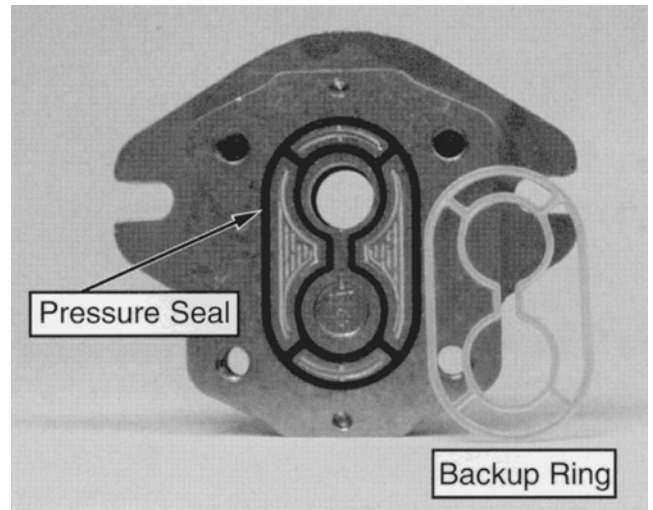

Figure 88

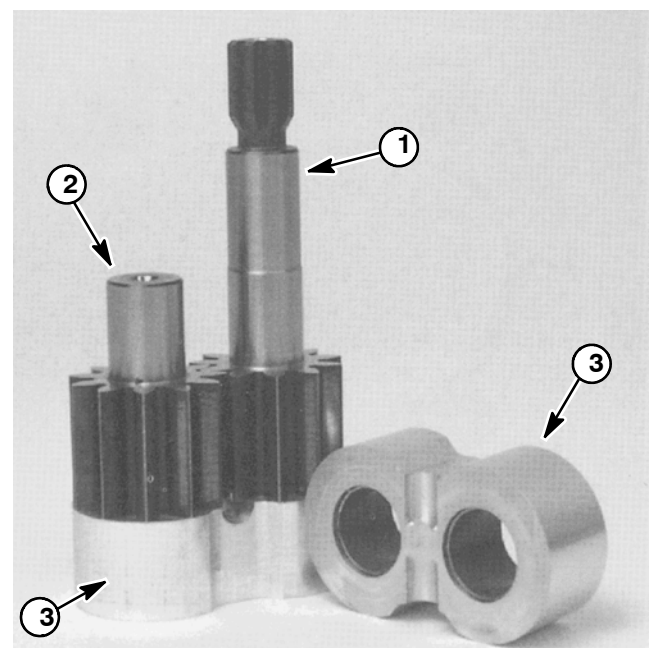

Figure 89

1. Drive gear
2. Idler gear

3. Bearing block

2. Clean all motor components with solvent. Dry all parts with compressed air.

3. Inspect drive gear, idler gear and bearing blocks (Fig. 89) for the following:

A. Gear shafts should be free of rough surfaces and excessive wear at bushing points and sealing areas. Scoring, rough surfaces or wear on gear shafts indicates need for replacement.

B. Gear teeth should be free of excessive scoring and wear. Any broken or nicked gear teeth must be replaced.

C. Inspect gear face edge for sharpness. Sharp edges of gears will mill into bearing blocks and, thus, must be replaced.

D. Bearing areas of bearing blocks should not have excessive wear or scoring.

E. Face of bearing blocks that are in contact with gears should be free of wear, roughness or scoring.

4. Inspect front flange and rear cover for damage or wear.

Assembly (Fig. 85)

NOTE: When assembling the motor, check the marker line made during disassembly to make sure the parts are properly aligned during assembly.

1. Lubricate new O-rings, pressure seals, back-up gaskets and seal grooves with a thin coat of petroleum jelly. Lubricate all other internal parts freely with clean hydraulic oil.

2. Install new shaft seal(s) into front flange. Install seal retainer.

NOTE: Pressure seals and back-up rings in Sauer-Danfoss motors fit in grooves machined into front and rear cover (Fig. 88). Pressure seals and back-up rings in Bosch motors fit in grooves machined into bearing blocks.

3. Install lubricated pressure seals into the machined grooves and follow by carefully placing the back-up rings into the grooves.

4. Install lubricated O-rings to the body.

5. Lubricate gear faces and bearing surfaces of drive gear, idler gear and bearing blocks with clean hydraulic oil. Carefully assemble bearing blocks and gears noting identification marks made during disassembly.

6. Position the motor body on its side. Carefully slide bearing block and gear assembly into the body cavity using identification marks made during disassembly.

7. Remove any excess lubrication from mating surfaces of body, rear cover and front flange. Make sure that these surfaces are clean and dry.

8. Install dowel pins in body.

IMPORTANT: Do not dislodge O-rings, pressure seals or back-up rings during final assembly.

9. Gently slide the rear cover onto the assembly using marker line for proper location. Firm hand pressure should be sufficient to engage the dowel pins.

10. Position the motor with rear cover downwards. Carefully slide the front flange onto the assembly using marker line for proper location. Take care to not damage the seal during front flange installation.

11. Install the four (4) cap screws and hand tighten.

IMPORTANT: Avoid using excessive clamping pressure on the motor front flange to prevent damage.

12. Place motor front flange in a vise and alternately torque the cap screws to the specifications identified in Figure 85.

13. On Bosch motor, lubricate and install new sealing washers on relief valves. Install relief valves into rear cover ports and torque from **11 to 15 ft-lb (15 to 20 N-m)**.

14. Put a small amount of hydraulic oil in port on motor and rotate driveshaft one revolution. Protect the shaft if using a pliers. If drive shaft binds, disassemble motor and repeat assembly process.

15. Remove motor from vise.

This page is intentionally blank.

Cutting Reel Motor Service (Casappa)

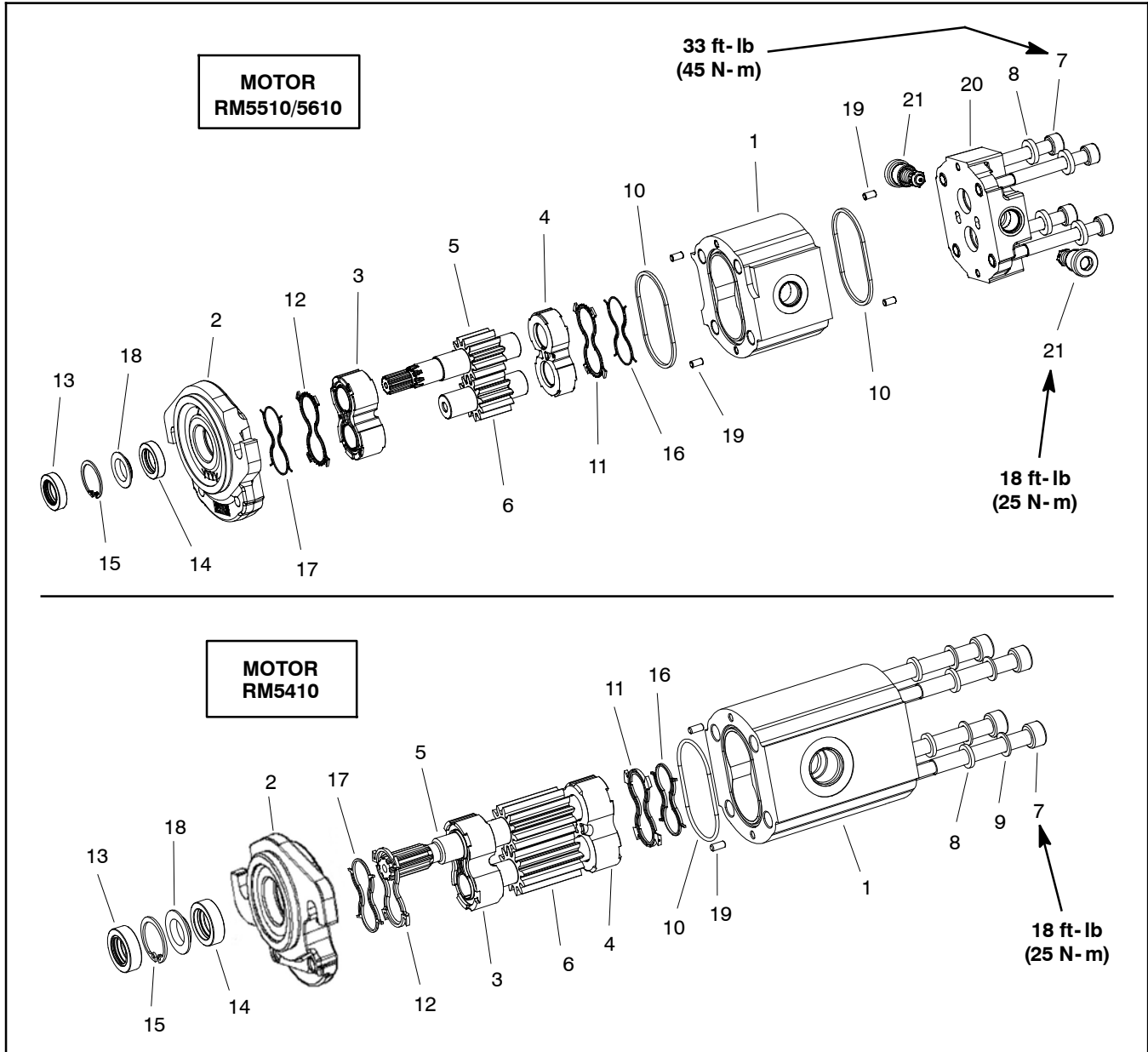

Figure 90

- | | | |
|-------------------------------|-------------------------|------------------------------------|
| 1. Body | 8. Flat washer (4 used) | 15. Retaining ring |
| 2. Front flange | 9. Lock washer (RM5410) | 16. Back-up seal |
| 3. Front thrust plate | 10. O-ring | 17. Back-up seal |
| 4. Rear thrust plate | 11. Pressure seal | 18. Flange washer |
| 5. Drive gear | 12. Pressure seal | 19. Dowel pin |
| 6. Idler gear | 13. Dust seal | 20. Rear cover (RM5510/5610) |
| 7. Socket head screw (4 used) | 14. Shaft seal | 21. Relief cartridge (RM5510/5610) |

NOTE: Casappa cutting reel motors used on Reelmaster 5410 machines are different than Casappa reel motors used on Reelmaster 5510 and 5610 machines. The motors used on Reelmaster 5510 and 5610 machines have a separate rear cover that includes two (2) cross-over relief valves. Both cutting reel motors are shown in Figure 90. The following disassembly, inspection and assembly procedures can be used for either motor.

NOTE: Internal components for a Casappa cutting reel motor are not available separately. Disassemble motor for cleaning, inspection and seal replacement only.

Disassembly (Fig. 85)

1. Plug motor ports and clean the outside of the motor thoroughly. After cleaning, remove plugs and drain any oil out of the motor.

2. Use a marker to make a **diagonal** line across the front flange and body for assembly purposes (Fig. 91).

IMPORTANT: Prevent damage when clamping the fan motor in a vise; clamp on the front flange only. Also, use a vise with soft jaws.

3. Clamp front flange of motor in a vise with soft jaws with the shaft end down.

4. Loosen socket head screws from the rear of the body.

5. Remove motor from the vise. Turn motor so that the shaft end is facing down. Remove socket head screws and washers.

6. On Reelmaster 5510 and 5610 reel motor, lift rear cover from motor assembly.

7. Carefully lift body straight up to remove from motor assembly. Make sure the rear wear plate remains on the drive and idler gear shafts. Remove and discard O-rings from the body. Locate and retrieve dowel pins.

IMPORTANT: Note position of the open and closed side of the wear plates before removing. Also, identify wear plates (front and rear) with a marker for proper assembly.

IMPORTANT: Mark the relative positions of the gear teeth and the thrust plates so they can be assembled in the same position. Do not touch the gear surfaces as residue on hands may be corrosive to gear finish.

8. Carefully remove rear wear plate, idler gear, drive gear and front wear plate from the front flange.

9. Remove and discard back-up gaskets and pressure seals from wear plates.

10. Turn front flange over, with seal side up.

IMPORTANT: Make sure to not damage the front flange counter bore when removing the seals from the front flange.

11. Carefully remove dust seal, retaining ring, flange washer and shaft seal from the front flange. Note orientation of seal lips during removal (Fig. 92). Discard removed seals.

12. On Reelmaster 5510 and 5610 motor, remove cross-over relief valves from rear flange if necessary

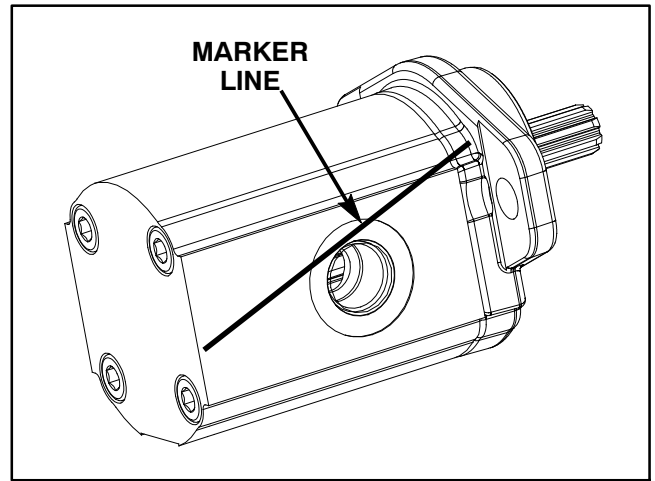

Figure 91

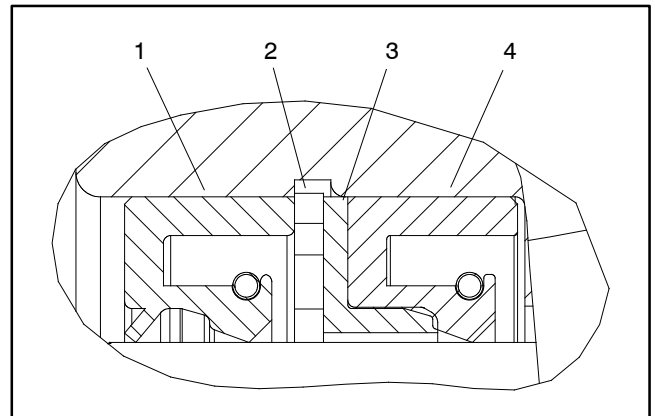

Figure 92

- 1. Dust seal
- 2. Retaining ring
- 3. Flange washer
- 4. Shaft seal

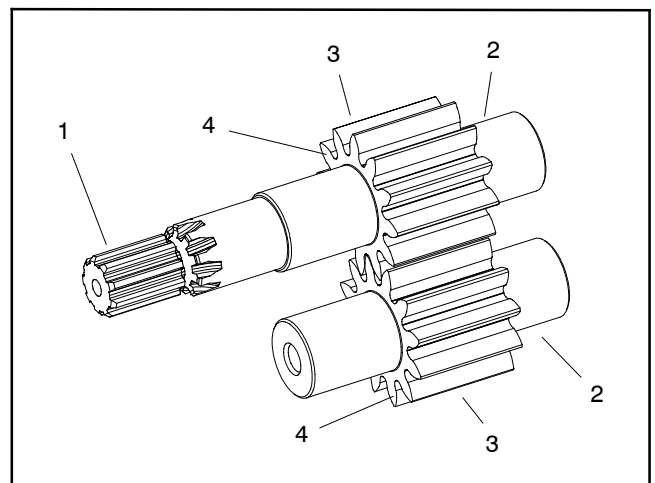

Figure 93

- 1. Gear shaft spline
- 2. Gear shaft
- 3. Gear teeth
- 4. Gear face edge

Inspection

1. Remove any nicks and burrs from all motor parts with emery cloth.



2. Clean all motor parts with solvent. Dry all parts with compressed air.
3. Inspect drive gears and idler gears for the following (Fig. 93):
 - A. Gear shafts should be free of scoring, rough surfaces and excessive wear at bushing points and sealing areas
 - B. Gear teeth should be free of excessive scoring, broken or nicked gear teeth and visual wear.
 - C. Inspect gear face edge for sharpness because sharp edges of gears will mill into wear plates.
4. Inspect wear plates for the following:
 - A. Bearing areas should not have excessive wear or scoring.
 - B. Face of wear plates that are in contact with gears should be free of wear, roughness or scoring.
 - C. Thickness of wear plates should be equal.
5. Inspect front flange and body for damage or wear.
6. If internal parts are found to be worn or damaged, motor replacement is necessary.

Assembly (Fig. 85)

NOTE: When assembling motor, check all marker line made during disassembly to make sure parts are properly aligned during assembly.

1. Lubricate O-rings, pressure seals, back-up gaskets and wear plate grooves with a thin coat of petroleum jelly. Lubricate all other internal parts freely with clean hydraulic oil.
2. Install new seals into front flange. Note orientation of seal lips during installation (Fig. 92):
 - A. Press shaft seal into front flange until it reaches the bottom of the bore.

- B. Install flange washer into front flange and then install retaining ring into the groove of the front flange. Make sure that retaining ring is fully seated in front cover groove.

- C. Install new dust seal into front flange.

3. Place front flange, seal side down, on a flat surface.
4. Install the pressure seals, flat side outward, into the grooves in the wear plates. Follow by carefully placing the backup gaskets, flat side outward, between the pressure seals and the grooves in the wear plate.
5. Apply a light coating of petroleum jelly to the exposed side of the front flange.
6. Lubricate the drive gear shaft with clean hydraulic oil. Insert the drive end of the drive shaft through the wear plate with the pressure seal side down and the open side of the pressure seal pointing to the inlet side of the motor. Carefully install shaft into front flange.
7. Lubricate the idler gear shaft with clean hydraulic oil. Install idler gear shaft into the remaining position in the front wear plate. Apply a light coating of clean hydraulic oil to gear faces.
8. Install rear wear plate with pressure seal side up and open side of the pressure seal pointing to the inlet side of the motor.
9. Apply a light coating of petroleum jelly to new O-rings and O-ring grooves in the body. Install new O-rings to the body.
10. Install locating dowels in body. Align marker line on the body and front flange.

IMPORTANT: Do not dislodge seals during body installation.

11. Gently slide the body onto the assembly. Firm hand pressure should be sufficient to engage the dowels.
12. On reel motor for Reelmaster 5510 or 5610:

- A. Make sure that lubricated O-ring and located dowels are installed in rear of body.
- B. Place rear cover onto the assembly. Firm hand pressure should be sufficient to engage the dowels.

13. Install the four (4) socket head screws with washers and hand tighten.

IMPORTANT: Prevent damage when clamping the fan motor into a vise; clamp on the front flange only. Also, use a vise with soft jaws.

14. Place front flange of the motor into a vise with soft jaws and alternately torque the socket head screws to the values identified in Figure 85.

15. On Reelmaster 5510 and 5610 reel motor, install cross-over relief valves into rear flange if they were removed. Torque relief valves **18 ft-lb (25 N-m)**.

16. Remove motor from vise.

17. Place a small amount of clean hydraulic oil in the inlet of the motor and rotate the drive shaft away from the inlet one revolution. If any binding is noted, disassemble the motor and check for assembly problems.

Lift Cylinder

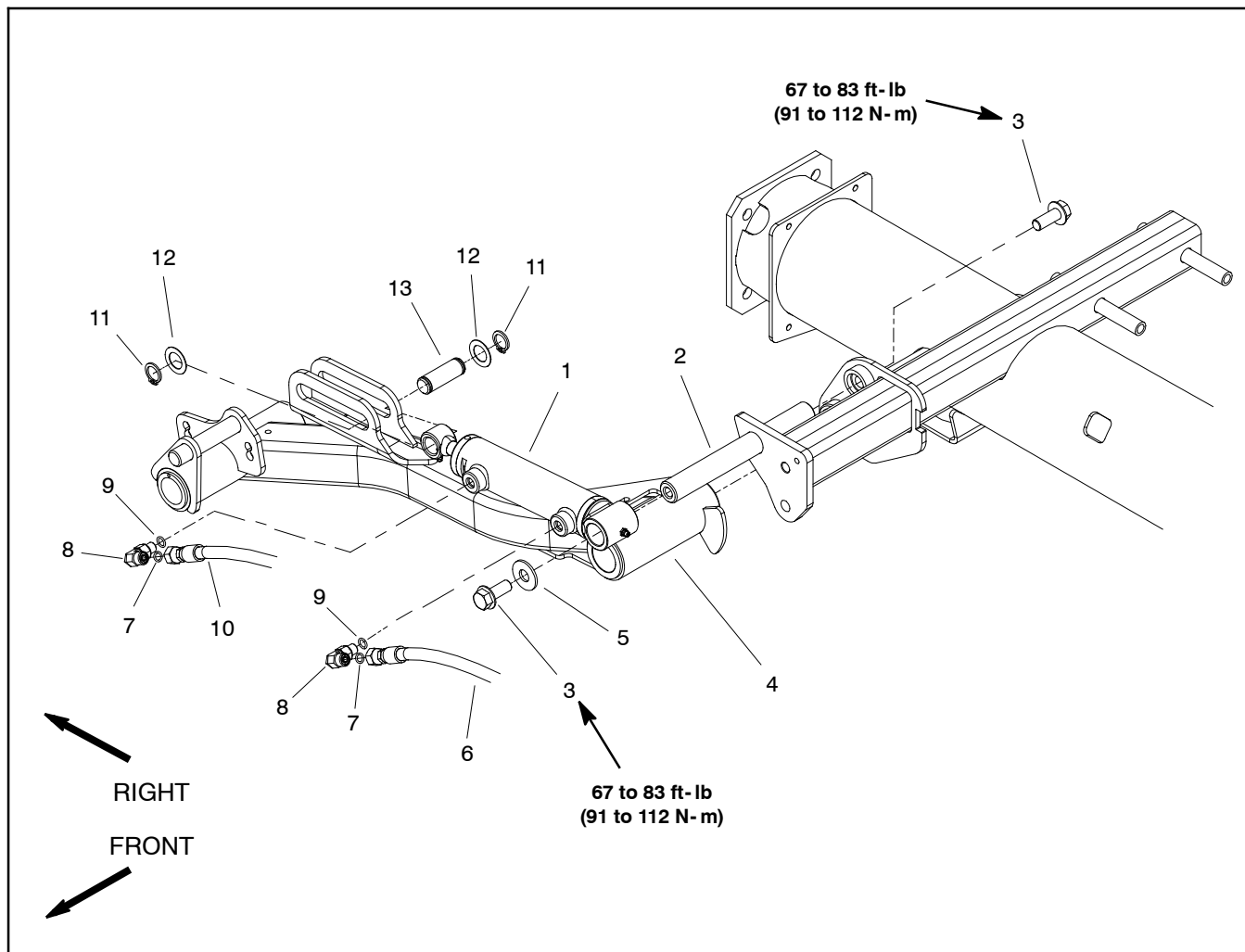

Figure 94

- | | | |
|------------------------------|--------------------------|------------------------|
| 1. Lift cylinder | 6. Hydraulic hose | 10. Hydraulic hose |
| 2. Pivot shaft | 7. O-ring | 11. Retaining ring |
| 3. Flange head screw | 8. 90° hydraulic fitting | 12. Thrust washer |
| 4. Lift arm (RH front shown) | 9. O-ring | 13. Cylinder slide pin |
| 5. Flat washer | | |

NOTE: The procedure for lift cylinder removal and installation is the same for all Reelmaster 5010 lift cylinders. Figure 94 shows the right, front lift cylinder.

Removal (Fig. 94)

1. Park the machine on a level surface, engage the parking brake, lower the cutting units and stop the engine. Remove the key from the ignition switch.
2. Read the General Precautions for Removing and Installing Hydraulic System Components at the beginning of the Service and Repairs section of this chapter.
3. Label all hydraulic connections for assembly purposes. Thoroughly clean hydraulic connections prior to loosening hydraulic lines from lift cylinder.



4. Disconnect hydraulic hoses from fittings in lift cylinder that is to be removed. Allow hoses to drain into a suitable container. Remove and discard O-rings.
5. Put caps or plugs on disconnected hoses and fittings to prevent contamination.
6. Remove one retaining ring (item 11) and thrust washer (item 12) from the cylinder slide pin (item 13). Pull pin from the lift cylinder and lift arm. Locate and retrieve second thrust washer.
7. Remove flange head screw (item 3) and flat washer (item 5) that retain lift cylinder to pivot shaft.
8. Remove lift cylinder from pivot shaft and frame.
9. If hydraulic fittings are to be removed from lift cylinder, mark fitting orientation to allow correct assembly. Remove fittings from lift cylinder and discard O-rings.

Installation (Fig. 94)

1. If hydraulic fittings were removed from lift cylinder, lubricate new O-rings, position O-rings to fittings and install fittings into lift cylinder ports (see Hydraulic Fitting Installation in the General Information section of this chapter). Make sure that fittings are orientated correctly.
2. Position lift cylinder to the frame with the barrel end up.
3. Slide lift cylinder clevis onto pivot shaft. Secure cylinder with flange head screw (item 3) and flat washer (item 5). Torque screw from **67 to 83 ft-lb (91 to 112 N-m)**.
4. Align lift cylinder to lift arm mounting slot. Slide cylinder slide pin (item 13) with thrust washer (item 12) through the lift cylinder and lift arm. Install second thrust washer on pin and secure with retaining ring (item 11).
5. Remove caps and plugs from disconnected hoses and fittings.
6. Coat new O-rings lightly with clean hydraulic oil, install new O-rings and connect hydraulic hoses to fittings on lift cylinder. Tighten hose connections.
7. Check oil level in hydraulic reservoir and add correct oil if necessary.
8. Lubricate lift cylinder grease fittings.
9. Follow Hydraulic System Start-up procedures (see Hydraulic System Start-up in this section).

Lift Cylinder Service

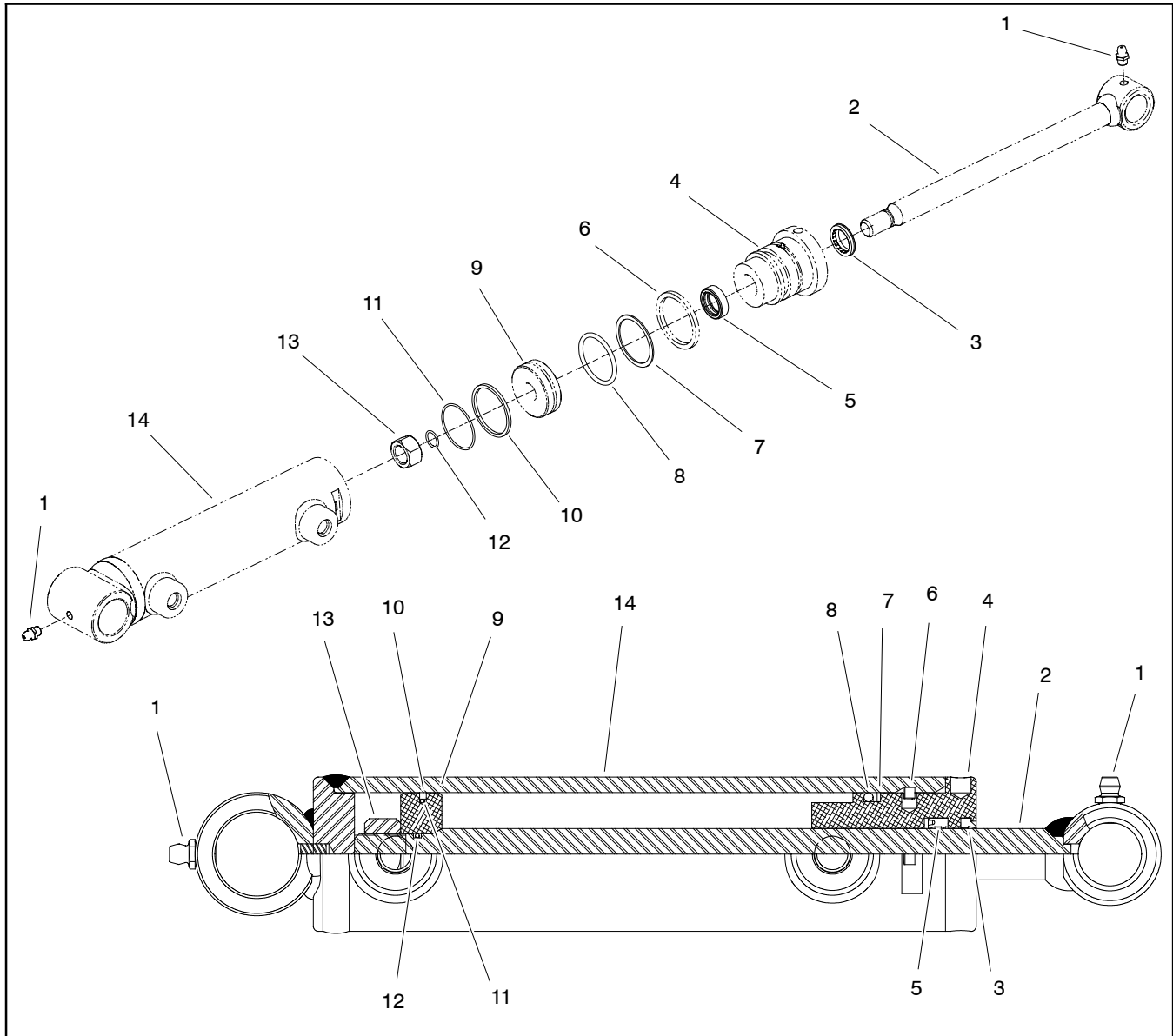

Figure 95

- | | | |
|-------------------|-------------------|--------------|
| 1. Grease fitting | 6. Retaining ring | 11. O-ring |
| 2. Shaft | 7. Back up washer | 12. O-ring |
| 3. Wiper | 8. O-ring | 13. Lock nut |
| 4. Head | 9. Piston | 14. Barrel |
| 5. U-Cup | 10. Cap seal | |

NOTE: The front, outside lift cylinders are longer with more stroke than the other lift cylinders which are identical. Service procedures for all lift cylinders used on Reelmaster 5010 machines are very similar.

Disassembly (Fig. 95)

1. Remove oil from lift cylinder into a drain pan by slowly pumping the cylinder shaft. Plug both ports and clean the outside of the cylinder.

IMPORTANT: Prevent damage when clamping the lift cylinder into a vise; clamp on the clevis end of the barrel ONLY.

2. Mount lift cylinder securely in a vise by clamping on the clevis end of the barrel. Use of a vise with soft jaws is recommended.

3. Using a spanner wrench, rotate head clockwise until the edge of the retaining ring appears in the barrel opening. Insert a screwdriver under the beveled edge of the retaining ring to start the retaining ring through the opening. Rotate the head counter-clockwise to remove retaining ring from barrel and head.

4. Remove plugs from ports. Extract shaft, head and piston by carefully twisting and pulling on the shaft.

IMPORTANT: Do not clamp vise jaws against the shaft surface. Clamp on the clevis ONLY.

5. Mount shaft securely in a vise by clamping on the clevis of the shaft. Remove lock nut and piston from the shaft. Carefully slide head off the shaft.

6. Taking care to not scratch or damage the piston, remove seals and O-rings from the piston.

7. Taking care to not scratch or damage the head, remove O-ring and seals from the head.

Inspection



1. Wash all lift cylinder components in solvent. Dry parts with compressed air.

2. Inspect internal surface of barrel for deep scratches, out-of-roundness and bending.

3. Inspect head, shaft and piston for excessive pitting, scoring and wear.

4. Replace lift cylinder if internal components are found to be worn or damaged.

Assembly (Fig. 95)

1. Make sure all lift cylinder parts are clean before assembly.

2. Coat new seal kit components with clean hydraulic oil.

A. Carefully install seals and O-rings to the piston.

B. Carefully install back-up washer, O-ring and other seals to the head.

IMPORTANT: Do not clamp vise jaws against the shaft surface. Clamp on the clevis ONLY.

3. Mount shaft securely in a vise by clamping on the clevis of the shaft.

A. Coat shaft with clean hydraulic oil.

B. Slide head onto the shaft.

C. Install piston onto the shaft and secure with lock nut. Identify cylinder part number that is stamped into barrel and use chart below to determine lock nut torque.

D. Remove shaft assembly from the vise.

IMPORTANT: Prevent damage when clamping the hydraulic cylinder into a vise; clamp on the clevis end of the barrel ONLY.

4. Mount barrel securely in a vise by clamping on the clevis end of the barrel.

IMPORTANT: When installing the head into the barrel, pay careful attention to the retaining ring slot in the barrel to insure that the piston and head seals do not lodge in the slot.

5. Coat all internal parts with a light coat of clean hydraulic oil. Slide piston, shaft and head assembly into the barrel being careful not to damage the seals.

6. Secure head in barrel by installing retaining ring. Align retaining ring hole in the head with the access slot in the barrel. Insert the retaining ring hook into the hole and rotate head clockwise until the retaining ring is completely pulled into the barrel and the ring ends are covered.

CYLINDER PART NUMBER	LOCK NUT TORQUE
107-2033	30 - 35 ft-lb (41 to 47 N-m)
107-2034	30 - 35 ft-lb (41 to 47 N-m)
ALL OTHERS	40 ft-lb (54 N-m)

Steering Control Valve

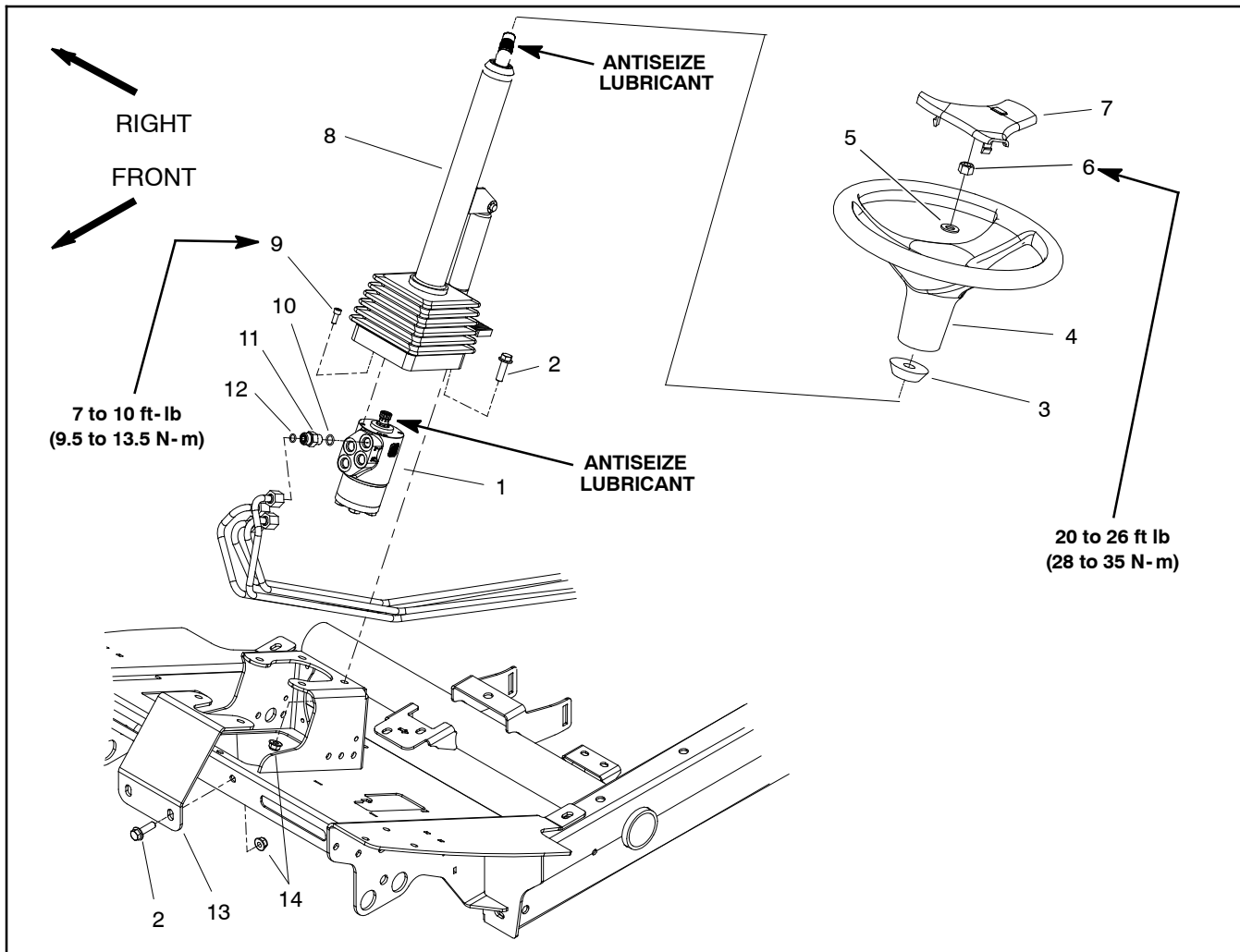

Figure 96

- | | | |
|---------------------------|-------------------------------|--------------------------------|
| 1. Steering control valve | 6. Lock nut | 11. Hydraulic fitting (4 used) |
| 2. Flange head screw | 7. Steering wheel cover | 12. O-ring |
| 3. Foam collar | 8. Steering column | 13. Steering column brace |
| 4. Steering wheel | 9. Socket head screw (4 used) | 14. Flange nut |
| 5. Flat washer | 10. O-ring | |

Removal (Fig. 96)

1. Park the machine on a level surface, engage the parking brake, lower the cutting units and stop the engine. Remove the key from the ignition switch.
2. Remove fasteners that secure shroud to front of machine (Fig. 97). Remove shroud from machine to allow access to steering control valve. Locate and retrieve two (2) rubber bushings and spacers.
3. Slide rubber bellows up from bottom of steering column. Support steering column to prevent it from falling.
4. Loosen and remove four (4) flange head screws and flange nuts that secure steering column brace (item 13) to machine. Remove brace.
5. Read the General Precautions for Removing and Installing Hydraulic System Components at the beginning of the Service and Repairs section of this chapter.
6. Label all hydraulic connections for assembly purposes. Note port designations on steering control valve (Fig. 98). Thoroughly clean hydraulic connections prior to loosening hydraulic lines.



CAUTION

Before opening hydraulic system, operate all hydraulic controls to relieve system pressure and avoid injury from pressurized hydraulic oil. See Relieving Hydraulic System Pressure in the General Information section of this chapter.

7. Disconnect hydraulic lines from steering control valve. Allow lines to drain into a suitable container.
8. Put caps or plugs on disconnected lines and fittings to prevent contamination.
9. Loosen and remove remaining two (2) flange head screws and flange nuts that secure steering column to machine.
10. Remove steering column assembly (Fig. 4) with steering control valve attached from machine.
11. Loosen and remove four (4) socket head screws that secure steering control valve to steering column.
12. Remove steering control valve from steering column.
13. If necessary, remove fittings and O-rings from steering control valve. Discard all removed O-rings.

Installation (Fig. 96)

1. If fittings were removed, lubricate new O-rings with clean hydraulic oil and install fittings to steering control valve (see Hydraulic Fitting Installation in the General Information section of this chapter).
2. Apply antiseize lubricant to splines of steering control valve shaft.
3. Slide steering control valve shaft into steering column universal joint. Position control valve with ports toward front of machine. Secure steering control valve to steering column with four (4) socket head screws. Hand tighten screws in a crossing pattern and then torque screws again in a crossing pattern from **7 to 10 ft-lb (9.5 to 13.5 N-m)**.
4. Position steering column assembly to machine. Secure steering column in place with two (2) flange head screws and flange nuts at rear two mounting holes.
5. Remove caps and plugs from disconnected lines and fittings.
6. Lubricate new O-rings and connect hydraulic lines to fittings on steering control valve. Tighten connections.

7. Position steering column brace (item 13) to machine and secure with four (4) flange head screws and flange nuts.
8. Slide rubber bellows to bottom of steering column.
9. Place rubber bushings and spacers into holes of shroud (Fig. 97). Position shroud in place and secure with removed fasteners.
10. Check oil level in hydraulic reservoir and add correct oil if necessary.
11. Follow Hydraulic System Start-up procedures (see Hydraulic System Start-up in this section).

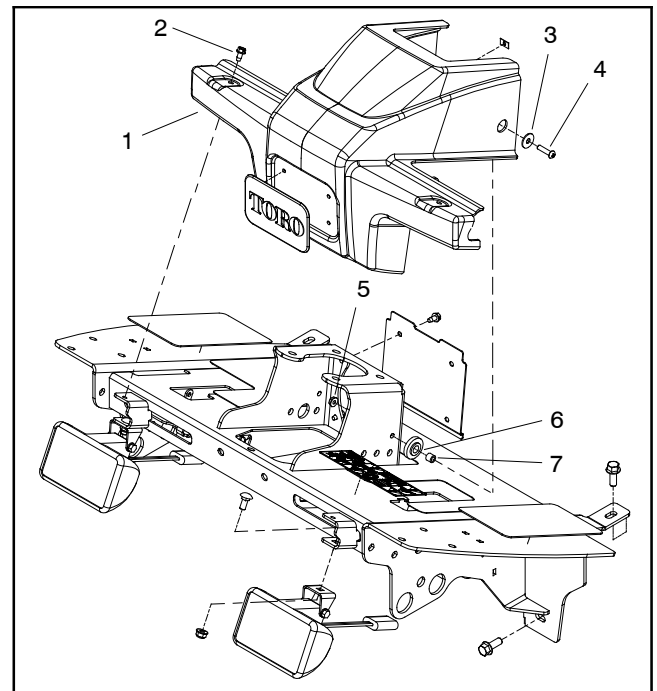

Figure 97

- | | |
|----------------------------|----------------------------|
| 1. Shroud | 5. Lock nut (2 used) |
| 2. Screw (2 used) | 6. Rubber bushing (2 used) |
| 3. Flat washer (2 used) | 7. Spacer (2 used) |
| 4. Phillips screw (2 used) | |

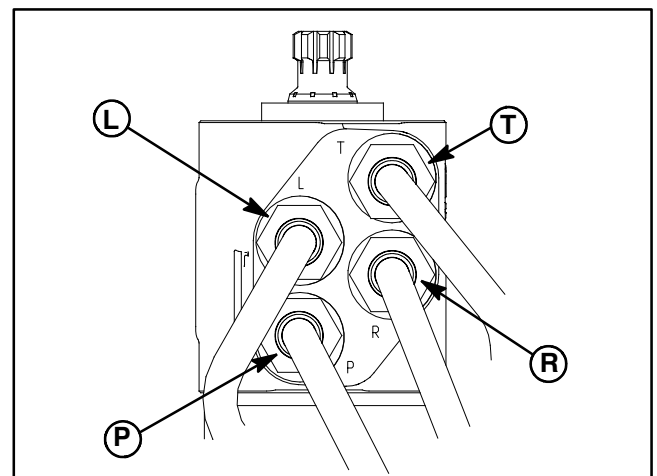

Figure 98

Steering Control Valve Service

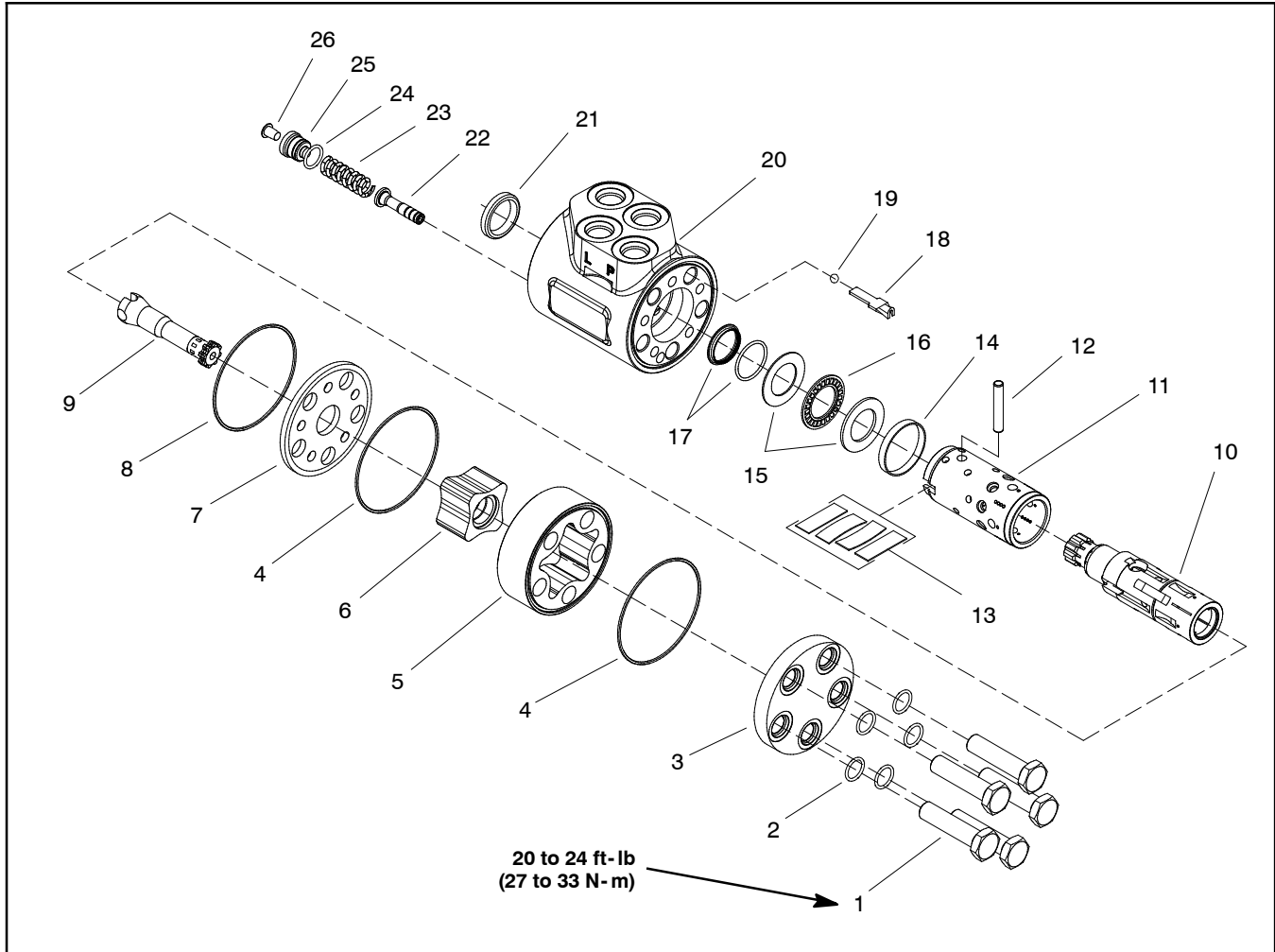

Figure 99

- | | | |
|----------------------|-------------------|--------------------|
| 1. Screw (5 used) | 10. Spool | 19. Check ball |
| 2. O-ring (5 used) | 11. Sleeve | 20. Housing |
| 3. End cover | 12. Cross pin | 21. Dust seal ring |
| 4. O-ring | 13. Spring set | 22. Relief valve |
| 5. Outer gearwheel | 14. Ring | 23. Spring |
| 6. Inner gearwheel | 15. Thrust washer | 24. O-ring |
| 7. Distributor plate | 16. Bearing | 25. Plug |
| 8. O-ring | 17. Shaft seal | 26. Plug |
| 9. Cardan shaft | 18. Ball stop | |

NOTE: For repair of the steering control valve, see the Sauer-Danfoss Steering Unit Type OSPM Service Manual at the end of this chapter.

This page is intentionally blank.

Steering Cylinder

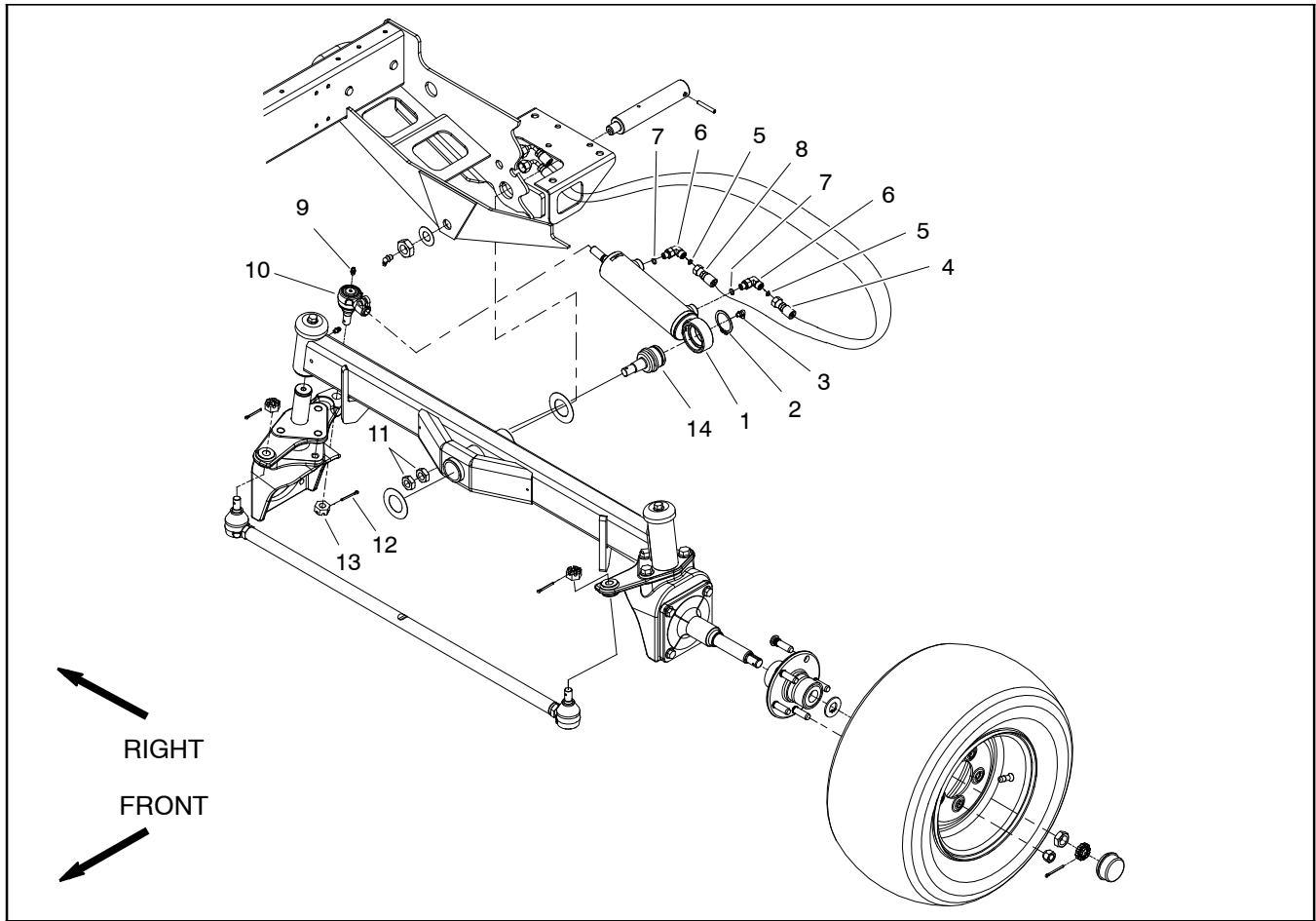

Figure

- 1. Steering cylinder
- 2. Retaining ring
- 3. Grease fitting
- 4. Hydraulic hose
- 5. O-ring

- 6. 90° hydraulic fitting
- 7. O-ring
- 8. Hydraulic hose
- 9. Grease fitting
- 10. Ball joint

- 11. Jam nut
- 12. Cotter pin
- 13. Slotted hex nut
- 14. Ball joint

Removal (Fig. 100)

1. Park the machine on a level surface, engage the parking brake, lower the cutting units and stop the engine. Remove the key from the ignition switch.
2. Read the General Precautions for Removing and Installing Hydraulic System Components at the beginning of the Service and Repairs section of this chapter.

**CAUTION**

Before opening hydraulic system, operate all hydraulic controls to relieve system pressure and avoid injury from pressurized hydraulic oil. See Relieving Hydraulic System Pressure in the General Information section of this chapter.

3. Label all hydraulic connections for assembly purposes. Thoroughly clean hydraulic hose ends prior to disconnecting hoses from the steering cylinder.
4. Disconnect hydraulic hoses from steering cylinder.
5. Put caps or plugs on disconnected hoses and fittings to prevent contamination.
6. Remove two (2) jam nuts (item 11) that secure steering cylinder to axle. Remove cotter pin (item 12) and slotted hex nut (item 13) that secure steering cylinder to RH drag link.
7. Separate ball joints from axle assembly and remove steering cylinder from machine.
8. If necessary, remove ball joints from steering cylinder barrel and shaft. If ball joint is to be removed from cylinder shaft, fully retract cylinder shaft and measure center to center length to ease installation of ball joint onto cylinder shaft (Fig. 101).
9. If hydraulic fittings are to be removed from steering cylinder, mark fitting orientation to allow correct assembly. Remove fittings from steering cylinder and discard O-rings.

Installation (Fig. 100)

1. If hydraulic fittings were removed from steering cylinder, lubricate new O-rings with clean hydraulic oil, position O-rings to fittings and install fittings into steering cylinder ports (see Hydraulic Fitting Installation in the General Information section of this chapter). Make sure that fittings are orientated correctly.

2. If removed, press ball joint into barrel and secure with retaining ring.
3. If ball joint was removed from cylinder shaft, fully retract cylinder shaft and thread ball joint onto shaft so that center to center length is as measured during removal process. Tighten clamp bolt and nut.
4. Thoroughly clean tapers on ball joints and axle assembly.
5. Position steering cylinder to machine.
6. Secure steering cylinder to axle with jam nuts (item 11). Torque first jam nut and then, while holding first jam nut with wrench, tighten second jam nut.
7. Secure steering cylinder to RH drag link with slotted hex nut (item 13). Install cotter pin (item 12).
8. Remove caps and plugs from hydraulic hoses and fittings.
9. Lubricate and install new O-rings on steering cylinder fittings. Correctly connect hydraulic hoses to steering cylinder.
10. Check oil level in hydraulic reservoir and add correct oil if necessary.
11. Lubricate cylinder ball joint grease fittings.
12. Follow Hydraulic System Start-up procedures (see Hydraulic System Start-up in this section).
13. Check that steering cylinder does not contact the axle or frame as cylinder moves from fully retracted to fully extended. Also, check that distance between the drag links and steering stops are equal on both sides of the machine. If necessary, adjust location of ball joint on cylinder shaft.

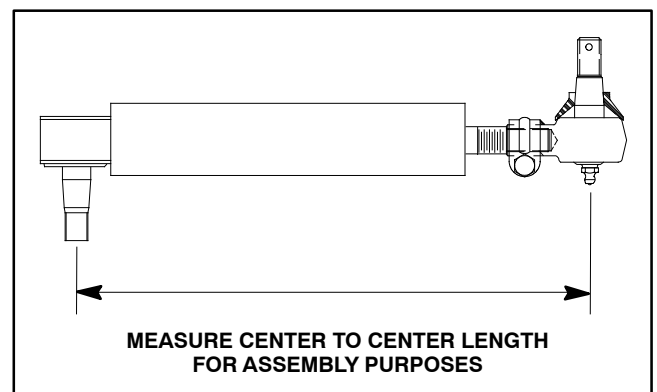
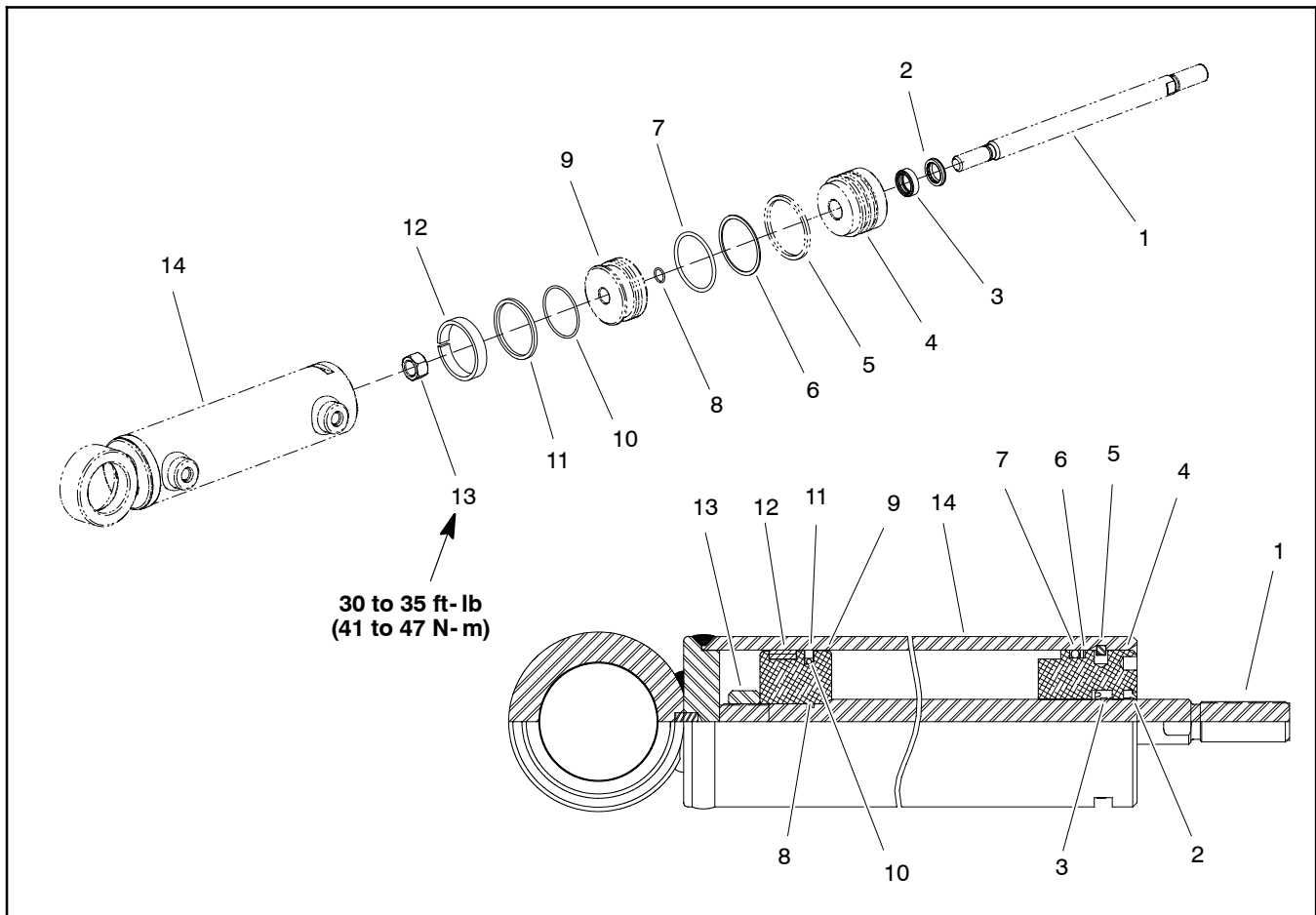

Figure 101

Steering Cylinder Service



Figure

- | | | |
|-------------------|---------------------|---------------|
| 1. Shaft | 6. Back-up ring 102 | 11. Cap seal |
| 2. Wiper | 7. O-ring | 12. Wear ring |
| 3. U-Cup | 8. O-ring | 13. Lock nut |
| 4. Head | 9. Piston | 14. Barrel |
| 5. Retaining ring | 10. O-ring | |

Disassembly (Fig. 102)

1. Remove oil from steering cylinder into a drain pan by slowly pumping the cylinder shaft. Plug both ports and clean the outside of the cylinder.

IMPORTANT: Prevent damage when clamping the steering cylinder into a vise; clamp on the clevis end of the barrel ONLY.

2. Mount steering cylinder securely in a vise by clamping on the clevis end of the barrel. Use of a vise with soft jaws is recommended.

3. Using a spanner wrench, rotate head clockwise until the edge of the retaining ring appears in the barrel opening. Insert a screwdriver under the beveled edge of the retaining ring to start the retaining ring through the opening. Rotate the head counter-clockwise to remove retaining ring from barrel and head.

4. Remove plugs from ports. Extract shaft, head and piston by carefully twisting and pulling on the shaft.

IMPORTANT: To prevent shaft damage, do not clamp shaft surface in a vise.

5. Using a wrench on shaft flats to prevent shaft from rotating, remove lock nut.

6. Carefully slide piston and then head from shaft.

7. Taking care to not scratch or damage the piston, remove wear ring, cap seal and O-ring from the piston.

8. Taking care to not scratch or damage the head, remove O-ring, back-up ring, wiper and u-cup from the head.

Inspection



1. Wash all cylinder components in solvent. Dry parts with compressed air.
2. Inspect internal surface of barrel for deep scratches, out-of-roundness and bending. Replace if worn or damaged.
3. Inspect head, shaft and piston for excessive pitting, scoring and wear. Replace any worn or damaged parts.

Assembly (Fig. 102)

1. Make sure all cylinder parts are clean before assembly.
2. Coat new O- rings, back- up ring and other seals with clean hydraulic oil.
 - A. Carefully install O- ring, cap seal and wear ring to the piston.
 - B. Carefully install back- up ring, O- ring, u- cup and wiper to the head.

IMPORTANT: To prevent shaft damage, do not clamp shaft surface in a vise.

3. Coat shaft with clean hydraulic oil. Slide head and piston onto the shaft.

4. Using a wrench on shaft flats to prevent shaft from rotating, install lock nut. Torque lock nut from **30 to 35 ft- lb (41 to 47 N- m)**.

IMPORTANT: Prevent damage when clamping the steering cylinder into a vise; clamp on the clevis end of the barrel ONLY.

5. Mount barrel securely in a vise by clamping on the clevis end of the barrel.

IMPORTANT: When installing the head into the barrel, pay careful attention to the retaining ring slot in the barrel to insure that the piston and head seals do not lodge in the slot.

6. Coat all internal parts with a light coat of clean hydraulic oil. Slide piston, shaft and head assembly into the barrel being careful not to damage the seals.

7. Secure head in barrel by installing retaining ring. Align retaining ring hole in the head with the access slot in the barrel. Insert the retaining ring hook into the hole and rotate head clockwise until the retaining ring is completely pulled into the barrel and the ring ends are covered.

Oil Cooler

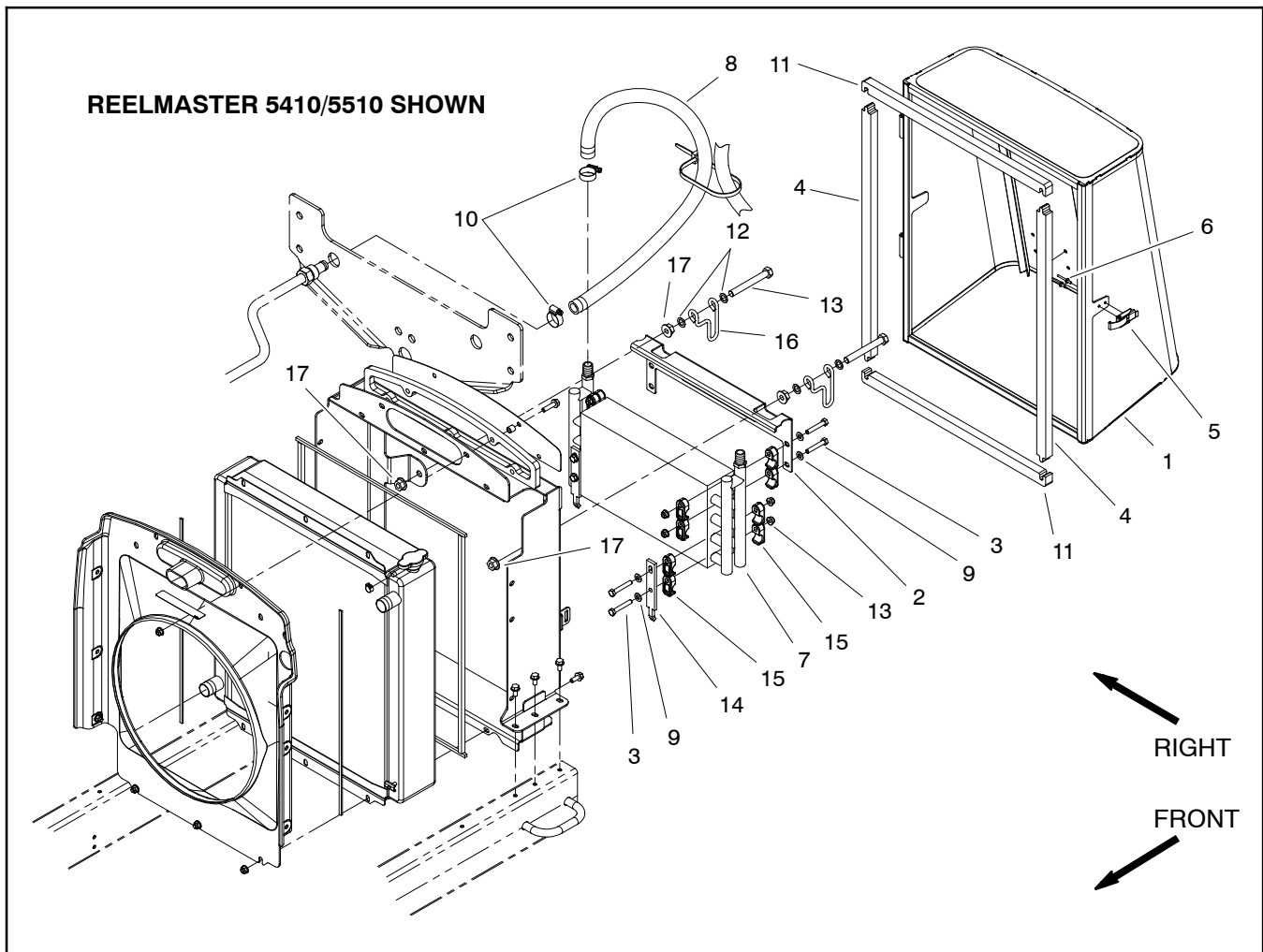

Figure

- | | | |
|-----------------------|----------------------------|--------------------------------|
| 1. Screen assembly | 7. Oil cooler 103 | 13. Cap screw (2 used) |
| 2. Oil cooler bracket | 8. Hydraulic hose (2 used) | 14. Mount plate (2 used) |
| 3. Cap screw (4 used) | 9. Flat washer (8 used) | 15. Oil cooler clamp (16 used) |
| 4. Foam seal (2 used) | 10. Hose clamp (4 used) | 16. Clamp (2 used) |
| 5. Draw latch | 11. Foam seal (2 used) | 17. Flange nut (4 used) |
| 6. Rivet (2 used) | 12. Washer (4 used) | |

NOTE: The oil cooler used on the Reelmaster 5610 is different than the oil cooler used on other Reelmaster 5010 machines. Figure 104 illustrates the oil cooler used on the Reelmaster 5610.

Removal (Fig. 103)

- Park machine on a level surface, lower cutting units, stop engine, engage parking brake and remove key from the ignition switch.
- Unlatch and open the rear screen.
- Label all hydraulic connections for assembly purposes. Thoroughly clean hydraulic connections prior to loosening hydraulic hoses.
- Loosen hose clamps that secure hydraulic hoses to oil cooler fittings. Remove hoses from oil cooler. Allow hoses to drain into a suitable container.
- Rotate clamps that secure oil cooler to radiator frame.
- Pull oil cooler from machine.
- If necessary, remove hydraulic fittings, clamps and brackets from oil cooler using Figures 103 and 104 as guides.

Inspection

1. Back flush oil cooler with cleaning solvent. After cooler is clean, make sure all solvent is drained from the cooler.



2. Dry inside of oil cooler using compressed air in the opposite direction of the oil flow.
3. Plug both ends of oil cooler. Clean exterior of cooler. Make sure oil cooler fins are clear of dirt and debris.
4. The oil cooler should be free of corrosion, cracked tubes and excessive pitting of tubes.

Installation (Fig. 103)

1. If removed, install hydraulic fittings, clamps and brackets to oil cooler using Figures 103 and 104 as guides. On Reelmaster 5210 machines (not shown), apply hydraulic thread sealant on hydraulic fitting threads before installation.
2. Position oil cooler to radiator and secure with clamps.
3. Install hydraulic hoses to oil cooler fittings and secure with hose clamps.
4. Install radiator screen to machine. Close hood.
5. Check oil level in hydraulic reservoir and add correct oil if necessary.

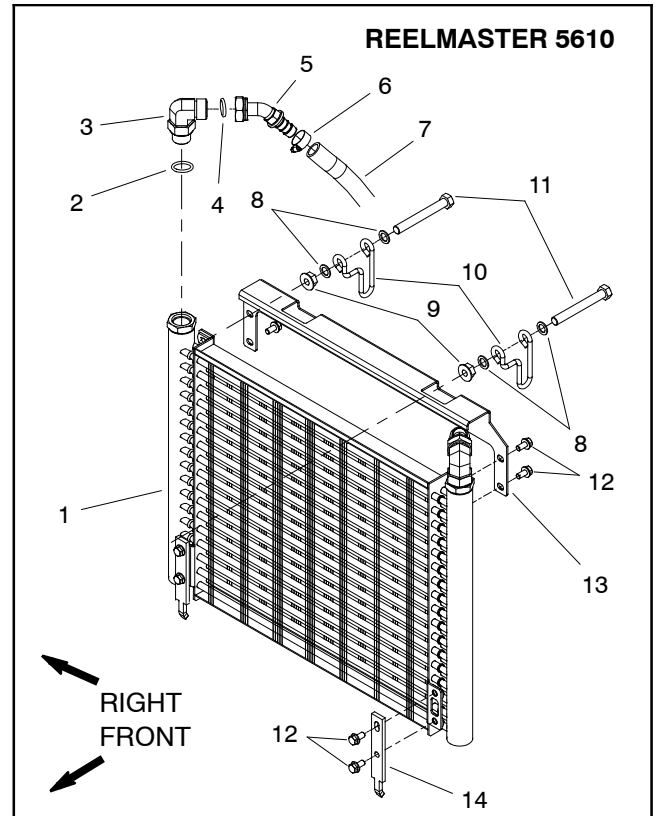

Figure 104

- | | |
|-------------------------|--------------------------|
| 1. Oil cooler | 8. Flat washer |
| 2. O-ring | 9. Flange nut (4 used) |
| 3. Hyd fitting (2 used) | 10. Clamp (2 used) |
| 4. O-ring | 11. Cap screw (2 used) |
| 5. Hyd fitting (2 used) | 12. Screw (8 used) |
| 6. Hose clamp | 13. Oil cooler bracket |
| 7. Hyd hose (2 used) | 14. Mount plate (2 used) |

This page is intentionally blank.



Electrical System

Electrical System

Table of Contents

GENERAL INFORMATION	1	Traction Neutral Switch	27
ELECTRICAL DIAGRAMS	1	Seat Switch	28
SPECIAL TOOLS	2	Headlight Switch	29
TROUBLESHOOTING	4	Parking Brake Switch	30
Diagnostic Light	4	Up Limit Switch	31
Retrieving Fault Codes	4	Joystick Raise and Lower Switches	32
Clearing Fault Codes	5	Mow/Transport Switch	33
Diagnostic Display	6	Backlap Switches	34
Verify Diagnostic Display Input Functions	6	Start Relay	35
Verify Diagnostic Display Output Functions	8	Main Power and Glow Relays	36
Electronic Control Module Logic Chart	9	Electronic Control Module (ECM)	37
Starting Problems	10	CAN- bus Termination Resistors (Machine With	
General Run and Transport Problems	12	Serial Number Above 280000000)	37
Cutting Unit Operating Problems	13	Diode Assembly	38
TurfDefender™ Leak Detector (Optional)	15	Fusible Link Harness	38
ELECTRICAL SYSTEM QUICK CHECKS	18	Fuses	39
Battery Test (Open Circuit Test)	18	Hydraulic Solenoid Valve Coil	40
Charging System Test	18	Temperature Sender	41
Glow Plug System Test	18	High Temperature Shutdown Switch	42
Check Operation of Interlock Switches	19	Oil Pressure Switch	43
ADJUSTMENTS	20	Fuel Stop Solenoid	44
Traction Neutral Switch	20	Fuel Pump	45
Parking Brake Switch	21	SERVICE AND REPAIRS	46
Up Limit Switch	22	Battery Storage	46
COMPONENT TESTING	23	Battery Care	46
Ignition Switch	23	Battery Service	47
Indicator Lights	24	Control Arm	50
Hour Meter	25	Hydraulic Solenoid Valve Coil	52
Temperature Gauge	25	Backlap Switches	53
PTO Switch	26	TurfDefender™ Leak Detector (Optional)	54

General Information

The Traction Unit Operator’s Manual provides information regarding the operation, general maintenance and maintenance intervals for your Reelmaster machine. Refer to that publication for additional information when servicing the machine.

Electrical Diagrams

The electrical schematic, electrical circuit drawings and wire harness drawings for Reelmaster 5010 series machines are located in Chapter 9 - Foldout Drawings.

Special Tools

Order Special Tools from your Toro Distributor.

Multimeter

The multimeter can test electrical components and circuits for current, resistance or voltage. Obtain this tool locally.

NOTE: Toro recommends the use of a DIGITAL Volt-Ohm-Amp multimeter when testing electrical circuits. The high impedance (internal resistance) of a digital meter in the voltage mode will make sure that excess current is not allowed through the meter. This excess current could cause damage to circuits not designed to carry it.

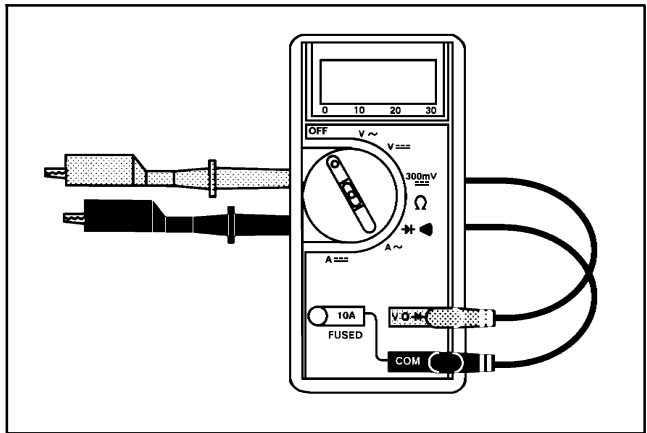

Figure 1

Battery Terminal Protector

Aerosol spray that should be used on battery terminals, ring terminals and fork terminals to reduce corrosion problems. Apply terminal protector to the connection after the battery cable, ring terminal or fork terminal has been secured.

Toro Part Number: **107-0392**



Figure 2

Dielectric Gel

Dielectric gel should be used to prevent corrosion of unsealed connection terminals. To ensure complete coating of terminals, liberally apply gel to both component and wire harness connector, plug connector to component, unplug connector, reapply gel to both surfaces and reconnect harness connector to component. Connectors should be thoroughly packed with gel for effective results.

Do not use dielectric gel on sealed connection terminals as the gel can unseat connector seals during assembly.

Toro Part Number: **107-0342**



Figure 3

Diagnostic Display

The Diagnostic Display (Fig. 4) is connected to the wiring harness connector located inside the control arm to verify correct electrical functions of the machine. Electronic Control Module (ECM) inputs and outputs can be checked using the Diagnostic Display.

Toro Part Number for Diagnostic Display: **85-4750**

Toro Part Number for Overlay (English): **110-0666**

NOTE: Diagnostic Display overlays are available in several languages for your Reelmaster. Refer to your Parts Catalog for overlay language options and part numbers.

IMPORTANT: The Diagnostic Display must not be left connected to the machine. It is not designed to withstand the environment of the machine's every day use. When use of Diagnostic Display is completed, disconnect it from the machine and reconnect loopback connector to harness connector. Machine will not operate without loopback connector installed on harness. Store Diagnostic Display in a dry, secure, indoor location, not on machine.



Figure 4

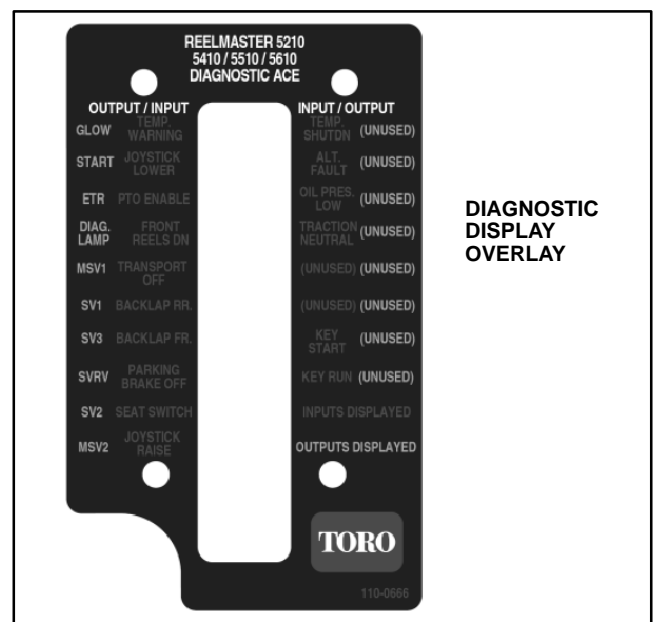

Figure 5

Battery Hydrometer

Use the Battery Hydrometer when measuring specific gravity of battery electrolyte. Obtain this tool locally.



Figure 6

Troubleshooting



CAUTION

Remove all jewelry, especially rings and watches, before doing any electrical troubleshooting or testing. Disconnect the battery cables unless the test requires battery voltage.

For effective troubleshooting and repairs, there must be a good understanding of the electrical circuits and components used on this machine (see Chapter 9 – Electrical Diagrams).

If the machine has any interlock switches by-passed, they must be reconnected for proper troubleshooting and safety.

NOTE: Use the Diagnostic Display (see Special Tools in this chapter) to test Electronic Control Module inputs and outputs when troubleshooting an electrical problem on your Reelmaster.

Diagnostic Light

Machines in the Reelmaster 5010 series are equipped with a diagnostic light that indicates if the machine electrical system is functioning correctly. The diagnostic light is located on the control panel (Fig. 7).

When the ignition switch is moved to the RUN position and the ECM is functioning properly, the diagnostic light will be illuminated for approximately 3 seconds and then will turn off. The light should remain off during normal machine operation.

If the ECM detects an electrical system malfunction (fault) during machine operation, the diagnostic light will flash rapidly. The light will stop flashing and will automatically reset when the ignition switch is turned to the OFF position. The fault, however, will be retained in ECM memory and can be retrieved at a future time.

If the diagnostic light does not illuminate when the ignition switch is turned to the RUN position, possible causes are:

1. Loopback harness is not connected to the wire harness.
2. The diagnostic light (or circuit wiring) is faulty.
3. ECM fuses are faulty.
4. The ECM is faulty.

Check electrical connections, ECM fuses and the diagnostic light to determine malfunction. Make sure loopback connector is secured to wire harness connector.

Retrieving Fault Codes

To retrieve faults from ECM memory, perform the following switch sequence:

1. Operator seat should be UNOCCUPIED, traction pedal in neutral and PTO switch in the OFF position.
2. Make sure that both mow/backlap levers are in MOW.

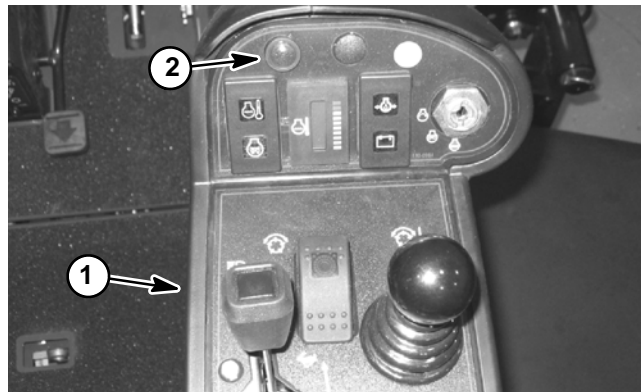

Figure 7

1. Control panel 2. Diagnostic light

3. Place mow/transport lever in TRANSPORT.
4. Move and hold joystick in the RAISE position.
5. Turn ignition switch to RUN.
6. Monitor the diagnostic light for fault code(s).

NOTE: Once the diagnostic light begins to display fault codes, the joystick can be released.

A fault code will be displayed by the diagnostic light as two groups of up to 5 flashes with approximately 1 second between the two groups. If multiple faults have occurred, the three most recent faults will be displayed with the oldest of those faults being shown last. Fault codes for multiple faults will be displayed with a 2 to 3 second pause in light flashes between fault codes. After the three fault codes have been displayed, there will be a 4 to 5 second pause and the fault codes will be repeated. If no faults are retained in ECM memory, the diagnostic light will flash continuously after following the above switch sequence. Fault codes are shown on the following page.

Fault Code (Lamp Flashes)	Fault Description
1 - 1	High engine temp warning occurred (PTO was shutdown by ECM)
1 - 2	High engine temp shutdown occurred (engine was shutdown by ECM)
1 - 3	Low engine oil pressure occurred
1 - 4	Engine alternator fault occurred
1 - 5	Charging system voltage was incorrect (check charging system)
1 - 6	Internal ECM fault
2 - 1	Check ECM output fuse 1
2 - 2	Check ECM output fuse 2
2 - 3	Check ECM output fuse 3
2 - 4	No power to all ECM output fuses (check main power relay)
2 - 5	Leak in hydraulic system detected by optional leak detector (reels shutdown and leak detector alarm sounds)
3 - 1	Glow plug relay current was too high (check glow plug circuit)
3 - 2	Start relay current was too high (check starting circuit)
3 - 3	Fuel stop solenoid and fuel pump current were too high
3 - 5	MSV2 current was too high (check front mow electrical circuit)
4 - 1	SV1 current was too high (check cutting unit lift electrical circuit)
4 - 2	SV3 current was too high (check cutting unit lift electrical circuit)
4 - 3	SV2 current was too high (check cutting unit lift electrical circuit)
4 - 4	SVRV current was too high (check cutting unit lift electrical circuit)
4 - 5	MSV1 current was too high (check rear mow electrical circuit)
5 - 1	Signal from optional leak detector was lost
5 - 4	Internal ECM fault

Clearing Fault Codes

After fault codes have been retrieved, clearing of those faults from ECM memory can be completed using the following switch sequence:

1. Place machine switches in fault retrieval (see above). The diagnostic light should be displaying the fault codes.
2. Operator seat should remain UNOCCUPIED.
3. Move both mow/backlap levers to BACKLAP.
4. Move joystick to the RAISE position.
5. Monitor the diagnostic light for continuous flashing indicating that all faults have been cleared from ECM memory.

If a fault is not retrieved from ECM memory within 40 hours of machine operating time, the fault will be automatically cleared. Cleared faults will be retained in ECM memory and can be viewed by your Toro Distributor.

Diagnostic Display

Reelmaster 5010 machines are equipped with an Electronic Control Module (ECM) which controls machine electrical functions. The ECM monitors various input switches (e.g. ignition switch, seat switch, etc.) and energizes outputs to actuate solenoids or relays for the requested machine function.

For the ECM to control the machine as desired, each of the input switches, output solenoids and relays must be connected and functioning properly.

The Diagnostic Display is a tool to help the technician verify correct electrical functions of the machine.

IMPORTANT: The Diagnostic Display must not be left connected to the machine. It is not designed to withstand the environment of the machine's every day use. When use of the Diagnostic Display is completed, disconnect it from the machine and reconnect loopback connector to harness connector. The machine will not operate without the loopback connector installed on the harness. Store the Diagnostic Display in a dry, secure, indoor location, not on machine.

Verify Diagnostic Display Input Functions



CAUTION

The interlock switches are for the protection of the operator and bystanders and to ensure correct operation of the machine. Do not bypass or disconnect switches. Check the operation of the interlock switches daily for proper operation. Replace any malfunctioning switches before operating the machine.

1. Park machine on a level surface, lower the cutting units, stop the engine and engage the parking brake.
2. Open control panel cover. Locate wire harness and connectors near ECM. Carefully unplug loop back connector from harness connector (Fig. 8).
3. Connect the Diagnostic Display connector to the harness connector. Make sure correct overlay decal is positioned on the Diagnostic Display (Fig. 11).
4. Turn the ignition switch to the RUN position, but do not start machine.

NOTE: The **red** text on the overlay decal refers to input switches and the **green** text refers to outputs.

5. The “inputs displayed” LED, on lower right column of the Diagnostic Display, should be illuminated. If “outputs displayed” LED is illuminated, press the toggle button on the Diagnostic Display to change to “inputs displayed” LED.

6. The Diagnostic Display will illuminate the LED associated with each of the inputs when that input switch is closed. Individually, change each of the switches from open to closed (i.e., sit on seat, press traction pedal, etc.), and note that the appropriate LED on the Diagnostic Display will illuminate when the corresponding switch is closed. Repeat on each switch that is possible to be changed by hand.

7. If appropriate LED does not toggle on and off when switch state is changed, check all wiring and connections to that switch and/or test switch (see Component Testing in this chapter). Replace any defective switches and repair any damaged wiring.

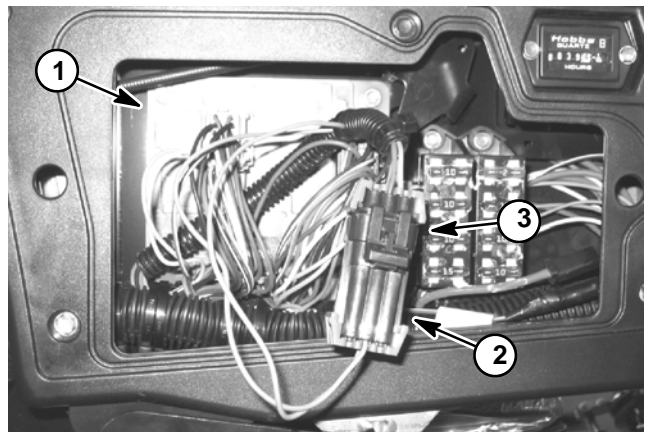

Figure 8

1. ECM location
2. Loopback connector
3. Harness connector

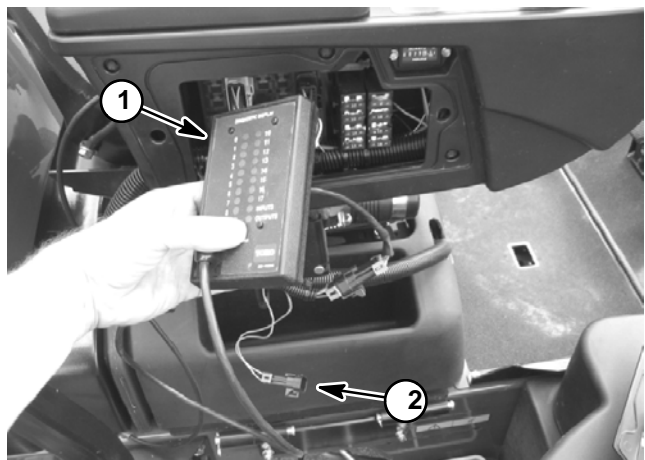

Figure 9

1. Diagnostic display
2. Loopback connector

Diagnostic Display ECM Inputs	Fault Description
TEMP WARN	Excessive engine temperature: LED ON Normal engine temperature: LED OFF
JOYSTICK LOWER	Joystick moved forward: LED ON Joystick in neutral: LED OFF
PTO ENABLE	PTO switch ON: LED ON PTO switch OFF: LED OFF
FR REELS DN	Cutting units lowered: LED ON Cutting units raised: LED OFF
TRANSPORT OFF	Mow/Transport lever in MOW: LED ON Mow/Transport lever in TRANSPORT: LED OFF
BACKLAP RR	Rear CU Backlap lever in BACKLAP: LED ON Rear CU Backlap lever in MOW: LED OFF
BACKLAP FR	Front CU Backlap lever in BACKLAP: LED ON Front CU Backlap lever in MOW: LED OFF
P BRAKE OFF	Parking brake released: LED ON Parking brake applied: LED OFF
SEAT SWITCH	Seat occupied: LED ON Seat NOT occupied: LED OFF
JOYSTICK RAISE	Joystick moved rearward: LED ON Joystick in neutral: LED OFF
TEMP SHUTDN	Very excessive engine temperature: LED ON Normal engine temperature: LED OFF
ALT FAULT	Engine not running or alternator faulty: LED ON Alternator OK: LED OFF
OIL PRES LOW	Engine not running OR low engine oil pressure: LED ON Engine oil pressure OK: LED OFF
TR NEUTRAL	Traction pedal in neutral: LED ON Traction pedal in forward or reverse: LED OFF
KEY START	Ignition switch in START: LED ON Ignition switch in RUN or OFF: LED OFF
KEY RUN	Ignition switch in RUN or START: LED ON Ignition switch in OFF: LED OFF

NOTE: The TEMP WARN and ALT FAULT ECM inputs can not be reliably tested by grounding the harness leads at the engine temperature sensor or alternator. If engine temperature is very excessive or alternator is faulty, an ECM fault should have been detected. Refer to Diagnostic Light in this section for information on retrieval and clearing of ECM faults.

NOTE: When the ignition switch is in the OFF position, all Diagnostic Display LED's should be OFF.

Verify Diagnostic Display Output Functions

The Diagnostic Display also has the ability to detect which output solenoids or relays are turned on by the ECM. This is a quick way to determine if a machine malfunction is electrical or hydraulic.

NOTE: An open output (e.g. an unplugged connector or a broken wire) cannot be detected with the Diagnostic Display.

1. Park machine on a level surface, lower the cutting units, stop the engine and engage the parking brake.
2. Open control panel cover. Locate wire harness and connectors near ECM. Carefully unplug loop back connector from harness connector (Fig. 10).
3. Connect the Diagnostic Display connector to the harness connector. Make sure correct overlay decal is positioned on the Diagnostic Display (Fig. 11).
4. Turn the ignition switch to the RUN position.

NOTE: The **red** text on the overlay decal refers to input switches and the **green** text refers to outputs.

5. The “outputs displayed” LED, on lower right column of the Diagnostic Display, should be illuminated. If “inputs displayed” LED is illuminated, press the toggle button on the Diagnostic Display to change the LED to “outputs displayed”.

NOTE: It may be necessary to toggle between “inputs displayed” and “outputs displayed” several times to perform the following step. To change from inputs to outputs, press toggle button once. This may be done as often as required. **Do not press and hold toggle button.**

6. Sit on seat and attempt to operate the desired function of the machine. The appropriate output LED’s should illuminate on the Diagnostic Display to indicate that the ECM is turning on that function. The Glow, Start, ETR and Diag. Lamp outputs can be checked with the ignition switch in the RUN position and the engine not running. For testing of the solenoid outputs (MSV1, SV1, SV3, SVRV, SV2 and MSV2), the engine must be running.

NOTE: If the “diag. lamp” output LED is blinking, this indicates an ECM fault has occurred. Refer to Diagnostic Light in this section for information on retrieval and clearing of ECM faults.

A. If the correct output LED’s do not illuminate, verify that the required input switches are in the necessary positions to allow that function to occur (see Electronic Control Module Logic Chart in this section). Verify correct switch function.

B. If the output LED’s are on as specified, but the machine does not function properly, suspect a non-electrical problem (e.g. hydraulic component problem). Repair as necessary.

C. If each input switch is in the correct position and functioning correctly, but the output LED’s are not correctly illuminated, this indicates an ECM problem. If this occurs, contact your Toro Distributor for assistance.

7. After output function testing is completed, disconnect the Diagnostic Display from wire harness. Plug loop back connector into harness connector. Install control panel cover.

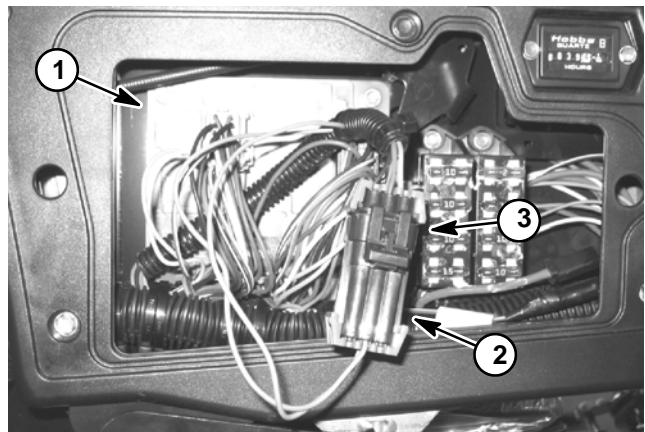

Figure 10

1. ECM location
2. Loopback connector
3. Harness connector

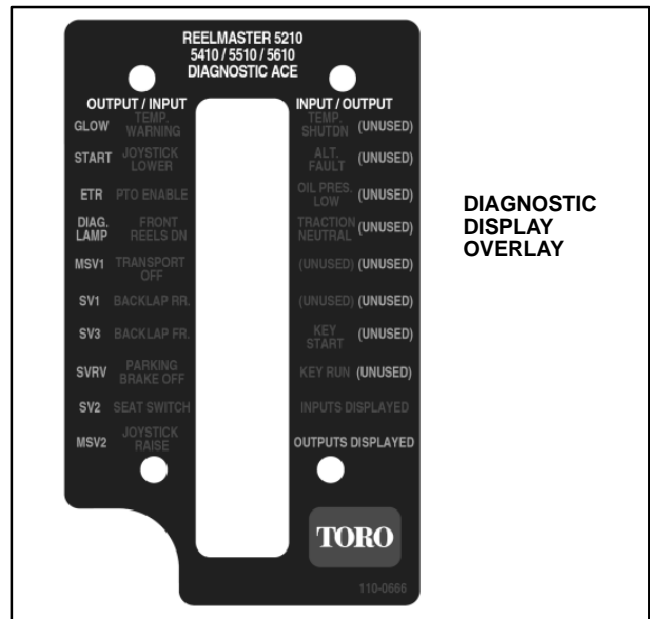

Figure 11

Electronic Control Module Logic Chart

Each line of the following chart identifies the necessary component position (INPUTS) in order for the Electronic Control Module (ECM) to energize the appropriate OUTPUTS for machine operation.

Example: To start the engine with no operator in the seat, when the ignition key is in start, the traction pedal is in neutral and the parking brake is applied, the glow plugs and other necessary engine starting components will be energized.

KEY TO CHART

- | |
|---|
| X |
|---|

 Component (Input) Position
- | |
|--|
| |
|--|

 Not Relevant for Function
- | |
|---|
| P |
|---|

 Component (Output) Energized

MACHINE FUNCTION	INPUTS														OUTPUTS									
	Ignition Key in RUN	Ignition Key in START	Traction Pedal in Neutral	Seat Occupied	Parking Brake Applied	Normal Coolant Temperature	Joystick Pulled to Rear (Raise)	Joystick Pushed Forward (Lower/Raise)	PTO Switch in ON	Mow/Transport Lever in Mow	Up Limit Switch Closed (C.U. Lowered)	Front C.U. in Backlap Position	Rear C.U. in Backlap Position	SV1 (Front Lift Cylinders) Energized	SV2 Energized	SV3 (Rear Lift Cylinders) Energized	SVRV Energized	MSV1 (Rear Reel Motors) Energized	MSV2 (Front Reel Motors) Energized	Engine Glow Plugs Energized	Engine Run Solenoid Hold Coil Energized	Engine Start (Run Solenoid and Start Solenoid Energized)		
Preheat	X																							
Start (No Operator in Seat)		X	X		X																	P		P
Start (Operator in Seat)		X	X	X																		P		P
Run (No Operator in Seat)	X		X		X	X																		P
Run (Operator in Seat)	X			X		X																		P
Lower Cutting Units to Ground	X							X	X					P		P	P							P
Mow (C.U. on Ground)	X			X		X			X	X	X								P	P				P
Raise (from Mow to Turn Around Position)	X			X			X		X	X	X			P	P	P	P							P
Lower/Mow (from Turn Around Position)	X			X		X		X	X	X				P		P	P	P	P					P
Raise (to Transport Position)	X						X							P	P	P	P							P
Initiate Backlap (Front C.U.)	X		X		X			X	X	X	X	X										P		P
Stop Backlap (Front C.U.)	X		X		X		X		X	X	X	X												P
Initiate Backlap (Rear C.U.)	X		X		X			X	X	X	X		X						P					P
Stop Backlap (Rear C.U.)	X		X		X		X		X	X	X		X											P
Diagnostic Light ECM Fault Retrieval	X		X				X																	
Clearing ECM Faults (From Retrieval Mode)	X						X					X	X											

NOTE: For **Start** machine function, the joystick must be in the neutral (center) position and the PTO switch must be OFF.

NOTE: The **Diagnostic Light ECM Fault Retrieval** machine function requires that the seat be unoccupied, the mow/transport lever be in the transport position, the PTO switch be OFF and both front and rear C.U. in the mow position.

NOTE: When the **Lower/Mow** machine function is completed, the front cutting units engage while lowering to the ground followed shortly by the rear cutting units engaging while lowering to the ground. The timing of this sequence is provided by the ECM.

Starting Problems

Problem	Possible Causes
All electrical power is dead, including gauges.	Battery is discharged. Ignition switch or circuit wiring is faulty. Fusible link harness at the engine starter motor is faulty. Battery cables are loose or corroded. Main fuse (15 amp) to the ignition switch is faulty.
Starter solenoid clicks, but starter will not crank. NOTE: If the starter solenoid clicks, the problem is not in the interlock circuit.	Battery is discharged. Battery cables are loose or corroded. Ground cable is loose or corroded. Wiring at the starter motor is faulty. Starter solenoid or starter motor is faulty.
Engine starts, but stops when the ignition switch is released from the START position.	Engine fuel stop solenoid or circuit wiring is faulty (pull coil operates but hold coil is faulty).
Engine cranks, but does not start.	Engine and/or fuel may be too cold. Fuel tank is empty. Glow plugs are faulty. Engine fuel stop solenoid or circuit wiring is faulty. Engine or fuel system is malfunctioning (see Chapter 3 - Kubota Diesel Engine). Hydraulic load is slowing engine cranking speed (disconnect hydraulic pump drive shaft from engine to test).

Starting Problems (Continued)

Problem	Possible Causes
Engine cranks, but should not, when the traction pedal is depressed.	<p>Traction neutral switch is out of adjustment.</p> <p>Traction neutral switch or circuit wiring is faulty.</p>
Nothing happens when start attempt is made. Control panel lights and gauges operate with the ignition switch in RUN.	<p>Traction pedal is not in neutral position.</p> <p>Operator seat is unoccupied OR the parking brake is not applied.</p> <p>Cutting units are engaged (PTO switch is ON).</p> <p>Traction neutral switch is out of adjustment.</p> <p>Traction neutral switch or circuit wiring is faulty.</p> <p>Seat switch or circuit wiring is faulty.</p> <p>Parking brake switch or circuit wiring is faulty.</p> <p>Joystick switch (raise or lower position) is faulty.</p> <p>Ignition switch or circuit wiring is faulty.</p> <p>Start relay or circuit wiring is faulty.</p> <p>Main power relay or circuit wiring is faulty (headlights and powerpoint inoperative as well).</p> <p>ECM fuses are faulty.</p> <p>Fusible link at battery is open.</p> <p>Wiring to start circuit components is loose, corroded or damaged (see Wiring Schematic and Circuit Drawings in Chapter 9 - Electrical Diagrams).</p> <p>High temperature shutdown switch or circuit wiring is faulty.</p> <p>Starter solenoid or starter motor is faulty.</p> <p>Electronic Control Module is faulty.</p>

General Run and Transport Problems

Problem	Possible Causes
Engine continues to run, but should not, when the ignition switch is turned off.	<p>Engine fuel stop solenoid is faulty.</p> <p>Ignition switch or circuit wiring is faulty.</p> <p>Main power relay or circuit wiring is faulty.</p>
Engine continues to run, but should not, when the traction pedal is engaged with no operator in the seat.	<p>Seat switch or circuit wiring is faulty.</p> <p>Traction neutral switch is out of adjustment.</p> <p>Traction neutral switch or circuit wiring is faulty.</p> <p>ECM fuses are faulty.</p> <p>Electronic Control Module is faulty.</p>
<p>The engine stops during operation, but is able to restart.</p> <p>NOTE: If excessive coolant temperature causes engine shutdown, the operator can restart the engine to allow the machine to be moved a short distance. After a restart in this condition, the engine will run for approximately 10 seconds before the engine shuts down again.</p>	<p>Parking brake is engaged.</p> <p>Operator is raising from the seat (seat switch not fully depressed).</p> <p>Seat switch or circuit wiring is faulty.</p> <p>Ignition switch or circuit wiring is faulty.</p>
The engine kills when the traction pedal is depressed.	<p>Parking brake is engaged.</p> <p>Operator is not fully depressing the seat switch.</p> <p>Seat switch or circuit wiring is faulty.</p> <p>ECM fuses are faulty.</p> <p>Electronic Control Module is faulty.</p>
Battery does not charge.	<p>Wiring to charging circuit components is loose, corroded or damaged (see Wiring Schematic and Circuit Drawings in Chapter 9 - Electrical Diagrams).</p> <p>Alternator belt is loose or damaged.</p> <p>Battery cables are loose or corroded.</p> <p>Fusible link harness at the engine starter motor is faulty.</p> <p>Alternator is faulty.</p> <p>Battery is faulty.</p>

Cutting Unit Operating Problems

Problem	Possible Causes
The cutting units remain engaged, but should not, with no operator in the seat.	Seat switch or circuit wiring is faulty. Electronic Control Module is faulty.
Cutting units run, but should not, when raised. Cutting units shut off with PTO switch.	Up limit switch or circuit wiring is faulty. Electronic Control Module is faulty.
Cutting units run, but should not, when raised. Cutting units do not shut off with PTO switch.	Both the up limit switch (or circuit wiring) and PTO switch (or circuit wiring) are faulty. A hydraulic problem in cutting circuit exists (see Troubleshooting section of Chapter 4 - Hydraulic System).
None of the cutting units operate in either direction (mow or backlap). Cutting units are able to raise and lower. NOTE: If the machine is equipped with the optional TurfDefender™ leak detection system, the cutting units will be shut off if a hydraulic leak is detected. The TurfDefender™ alarm should sound to indicate that a hydraulic leak has occurred.	PTO switch is in the OFF position. High coolant temperature disabled cutting units. Seat switch or circuit wiring is faulty. PTO switch or circuit wiring is faulty. Up limit switch or circuit wiring is faulty. Mow/transport switch or circuit wiring is faulty. Temperature sender or circuit wiring is faulty. Ground circuit wiring to hydraulic solenoids may be open. A hydraulic problem in cutting circuit exists (see Troubleshooting section of Chapter 4 - Hydraulic System).
Cutting units run, but should not, when lowered with joystick and PTO switch in the OFF position.	The PTO switch or circuit wiring is faulty. Electronic Control Module is faulty.
The front cutting units do not operate in either direction (mow or backlap). Rear cutting units operate. Cutting units are able to raise and lower.	Solenoid MSV2 or circuit wiring is faulty. A hydraulic problem in front mow circuit exists (see Troubleshooting section of Chapter 4 - Hydraulic System).
The rear cutting units do not operate in either direction (mow or backlap). Front cutting units operate. Cutting units are able to raise and lower.	Solenoid MSV1 or circuit wiring is faulty. A hydraulic problem in rear mow circuit exists (see Troubleshooting section of Chapter 4 - Hydraulic System).

Cutting Unit Operating Problems (Continued)

Problem	Possible Causes
The cutting units do not run when placed in the backlap direction.	Cutting units are not fully lowered to ground. Front or rear backlap switch or circuit wiring is faulty. Up limit switch or circuit wiring is faulty. A hydraulic problem exists (see Troubleshooting section of Chapter 4 - Hydraulic System).
The cutting units do not backlap, but run in the forward direction instead.	A hydraulic problem exists (see Troubleshooting section of Chapter 4 - Hydraulic System).
None of the cutting units will lower.	Mow/transport lever is in the transport position. Lower/mow switch on joystick or circuit wiring is faulty. Mow/transport switch or circuit wiring is faulty. Solenoid SVRV or circuit wiring is faulty. Solenoid SV2 or circuit wiring is faulty. A hydraulic problem exists (see Troubleshooting section of Chapter 4 - Hydraulic System).
None of the cutting units will raise.	Front and/or rear backlap levers are in backlap position. Raise switch on joystick or circuit wiring is faulty. Front and/or rear backlap switch or circuit wiring is faulty. Solenoid SVRV or circuit wiring is faulty. Solenoid SV2 or circuit wiring is faulty. A hydraulic problem exists (see Troubleshooting section of Chapter 4 - Hydraulic System).
Front cutting units will not raise or lower, but the rear cutting units will raise and lower.	Solenoid SV1 or circuit wiring is faulty. A hydraulic problem exists (see Troubleshooting section of Chapter 4 - Hydraulic System).
The rear cutting units will not raise or lower, but the front cutting units will raise and lower.	Solenoid SV3 or circuit wiring is faulty. A hydraulic problem exists (see Troubleshooting section of Chapter 4 - Hydraulic System).
One cutting unit (either front or rear) will not raise or lower, but all other cutting units will raise and lower.	A hydraulic problem exists (see Troubleshooting section of Chapter 4 - Hydraulic System).

TurfDefender™ Leak Detector (Optional)

The optional TurfDefender™ is an electronic hydraulic fluid leak detection device that fits inside the hydraulic reservoir of your machine (Fig. 12). It is a pressure based system which requires a sealed hydraulic reservoir to function properly. Very small changes to the oil level in the sealed reservoir result in movement of the leak detector's internal float. The internal microprocessor of the TurfDefender™ analyzes the float movement and determines if there is a leak in the hydraulic system.

- Turn ignition switch to "ON" position to start the system. The system will reset itself whenever the ignition switch is moved to "OFF". Wait 5 seconds, then move switch to "ON" position to restart the system.
- When the machine is started, the alarm should give one short beep to indicate that everything is operating properly. If the alarm makes no noise at all, see Checking TurfDefender™ Operation in this section.
- If the alarm gives 4 short beeps, a system problem has been detected and it should be checked by a technician.

NOTE: The 4 short beep signal may occur if the machine is started on a slope. Move machine to a level surface, move ignition switch to "OFF" position, wait 5 seconds, then move switch to "ON" position to restart the system. Repeat this cycle twice.

- If the alarm gives a loud continuous beep while mowing and the cutting units are shut off, a hydraulic leak has been detected. On the traction unit, the diagnostic light on the control panel will also blink indicating the ECM has shut off the cutting units.

4. Turn the ignition switch to the RUN position, but do not start machine.

NOTE: Red text on the overlay decal refers to inputs and green text refers to outputs.

5. The red "Inputs Displayed" LED (Light Emitting Diode), on lower right column of the Diagnostic Display, should be illuminated (Fig. 14). If green "Outputs Displayed" LED is illuminated, press and release the toggle button, on the Diagnostic Display, to change LED to "Inputs Displayed". **Do not hold toggle button down.**

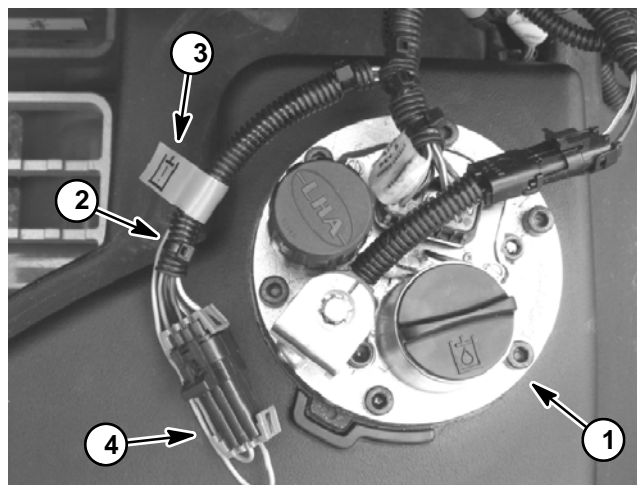

Figure 12

- | | |
|---------------------|-------------------------|
| 1. Leak detector | 3. Hydraulic symbol tag |
| 2. Loopback harness | 4. Loopback connector |

Checking TurfDefender™ Operation

When any of the following conditions occur, the operation of the TurfDefender™ should be checked:

- A. No beeps are heard when ignition switch is turned "ON".
- B. Any time the machine gives a series of 4 short beeps.
- C. False alarms are observed.

1. Park machine on a level surface, lower cutting units, stop engine and engage parking brake.

2. Raise hydraulic reservoir cover. Locate leak detector wire harness loopback connector identified with a green hydraulic symbol tag (Fig. 12). Carefully unplug loopback connector from harness connector.

3. Connect the Diagnostic Display connector to the correct harness loopback connector. Install TurfDefender™ overlay decal (supplied with TurfDefender™ kit) onto the Diagnostic Display (Fig. 13).

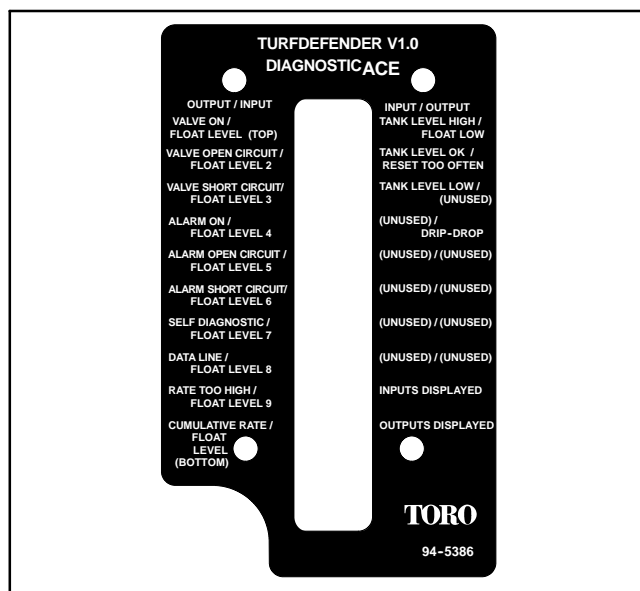

Figure 13

If TurfDefender™ is functioning normally:

1. When the “Inputs Displayed” LED is lit (Fig. 15):
 - A. The actual float position should be identified by 1 or 2 LED’s in the left column. The correct reservoir level is some combination of Float Levels 3 and/or 4.
 - B. The “Tank Level OK” LED should be illuminated.
2. Press toggle button until green “Outputs Displayed” LED is lit (Fig. 16).
 - A. “Valve ON”, “Data Line” and “Self Diagnostic” LED’s should be lit steadily.
 - B. “Alarm ON” LED may be displayed temporarily (about 5 seconds).

NOTE: If “data line” or “self diagnostic” LED’s are blinking, there is a problem in the system.

If no beeps are heard:

1. Check alarm wires to make sure they are not disconnected, broken or “+” and “-” reversed.
2. Make sure that TurfDefender™ wire harness is plugged in to machine wire harness.
3. Check 10 Amp main power fuse in fuse panel.
4. Toggle “Outputs Displayed” on the Diagnostic Display (Fig. 16). If “Alarm Open Circuit” or “Alarm Short Circuit” LED’s are blinking, check TurfDefender™ alarm or wires. Replace if necessary.

If 4 short beeps are heard:

The most common cause for a 4 short beep signal is from an improper oil level reading. Make sure machine is on a level surface when checking oil level. Since oil level will vary with temperature and cutting unit location (raised or lowered), it is best to check oil level when hydraulic oil is cool and cutting units are raised.

1. When toggling “inputs”, a LED should display any of the following problems diagnosed by the TurfDefender™ (Fig. 15):
 - A. Hydraulic oil level low: position machine on a level surface and fill to proper level.
 - B. Hydraulic oil level high: position machine on a level surface and remove excess oil until proper level is attained.
2. When toggling “outputs”, a LED should display any of the following problems diagnosed by the TurfDefender™ (Fig. 16):

- A. Valve Open Circuit LED blinking: check / replace TurfDefender™ electric solenoid valve or wires.
- B. Valve Short Circuit LED blinking: check / replace TurfDefender™ electric solenoid valve or wires.
- C. Self Diagnostic LED blinking: internal circuit failure in TurfDefender™.
- D. Data Line LED blinking: problem with communications between ECM and TurfDefender™; or problem with wires.
- E. Drip Drop LED blinking: a slow oil leak may be detected.

NOTE: If machine must be operated with TurfDefender™ disabled, unplug leak detector 4-pin connector from 4-pin connector of main wire harness. Do not unplug leak detector alarm.

If false alarms are observed:

1. Hydraulic oil level may be low causing air to be drawn out of the system. Check oil level.
2. Extremely hard turns can cause hydraulic oil to slosh in the hydraulic reservoir, exposing internal suction line and purging air from the system. Normal machine operation should not cause this condition.
3. An air leak exists in the system. Check to make sure cap is securely on reservoir.

NOTE: The system will reset itself whenever the ignition switch is turned to the “OFF” position. The handheld Diagnostic Display must be connected and observed during a false alarm. Once the ignition switch is turned to the “OFF” position, the TurfDefender™ will reset itself.

4. To check for a system problem, install handheld Diagnostic Display, toggle input/output and check for any problems previously discussed.
5. Your Authorized Toro Distributor has additional equipment to analyze TurfDefender™ system problems.

IMPORTANT: The Diagnostic Display must not be left connected to the machine. It is not designed to withstand the environment of the machine’s every day use. When use of the Diagnostic Display is completed, disconnect it from the machine and reconnect loopback connectors to harness connectors. Machine will not operate without loopback connectors installed on harness. Store the Diagnostic Display in a dry, secure, indoor location, not on machine.

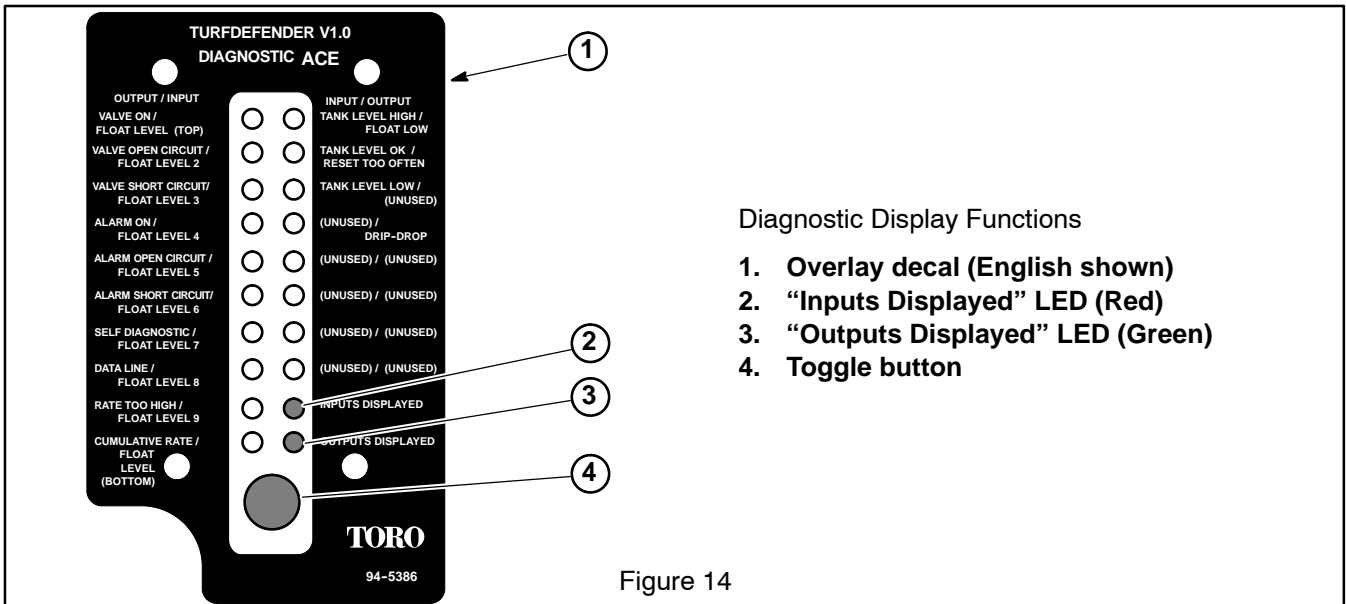

Figure 14

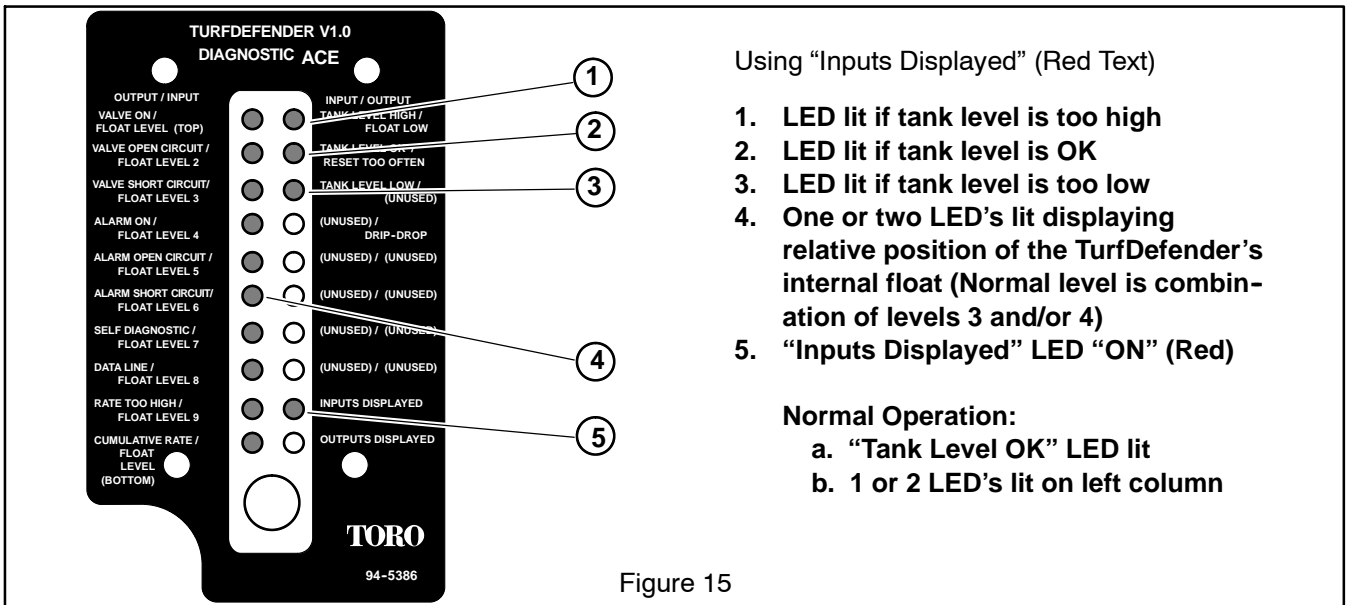

Figure 15

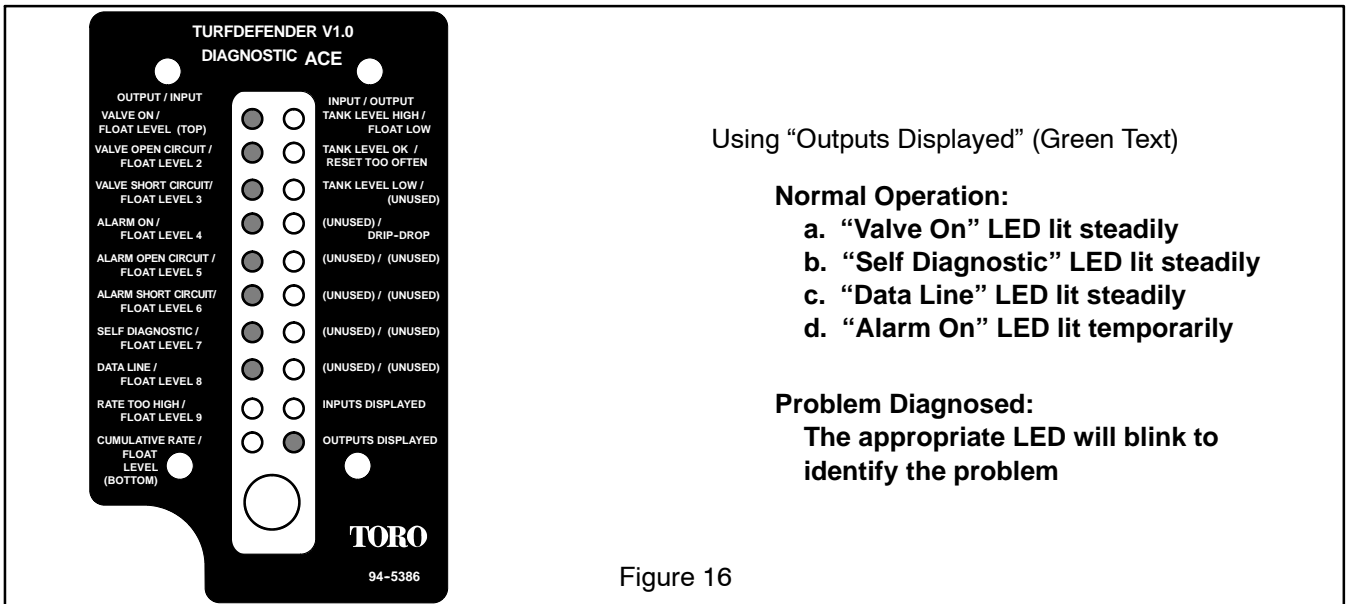

Figure 16

Electrical System Quick Checks

Battery Test (Open Circuit Test)

Use a digital multimeter to measure the battery voltage.

Set the multimeter to the DC volts setting. The battery should be at a temperature of 60° to 100° F (16° to 38° C). The ignition switch should be in the OFF position and all accessories turned off. Connect the positive (+) multimeter lead to the positive battery post and the negative (-) multimeter lead to the negative battery post. Record the battery voltage.

NOTE: This test provides a relative condition of the battery. Load testing of the battery will provide additional and more accurate information (see Battery Service in the Service and Repairs section).

Voltage Measured	Battery Charge Level
12.68 volts	Fully charged (100%)
12.45 volts	75% charged
12.24 volts	50% charged
12.06 volts	25% charged
11.89 volts	0% charged

Charging System Test

This is a simple test used to determine if a charging system is functioning. It will tell you if the charging system has an output, but not its capacity.

Use a digital multimeter set to DC volts. Connect the positive (+) multimeter lead to the positive battery post and the negative (-) multimeter lead to the negative battery post. Keep the test leads connected to the battery posts and record the battery voltage.

NOTE: Upon starting the engine, the battery voltage will drop and then should increase once the engine is running.

NOTE: Depending upon the condition of the battery charge and battery temperature, the battery voltage will increase at different rates as the battery charges.

Start the engine and run at high idle (**3200 RPM**). Allow the battery to charge for at least 3 minutes. Record the battery voltage.

After running the engine for at least 3 minutes, battery voltage should be at least 0.50 volt higher than initial battery voltage.

An example of a charging system that is functioning:

At least 0.50 volt over initial battery voltage.	
Initial Battery Voltage	= 12.30 v
Battery Voltage after 3 Minute Charge	= 12.85 v
Difference	= +0.55 v

Glow Plug System Test

This is a fast, simple test that can help to determine the integrity and operation of your Reelmaster glow plug system. The test should be run anytime hard starting (cold engine) is encountered on a diesel engine equipped with a glow plug system.

Use a digital multimeter and/or inductive Ammeter (AC/DC Current Transducer). Properly connect the ammeter to the digital multimeter (refer to manufacturers' instructions) and set the multimeter to the correct scale. With the ignition switch in the OFF position, place the

ammeter pickup around the main glow plug power supply wire and read the meter prior to activating the glow plug system. Adjust the meter to read zero (if applicable). Activate the glow plug system by turning the ignition switch to RUN and record the multimeter results.

The Reelmaster glow plug system should have a reading of approximately 9 Amps per glow plug (27 amps total on Reelmaster 5210 and 36 amps total on models with four cylinder engine). If low current reading is observed, one (or more) glow plugs is faulty.

Check Operation of Interlock Switches



CAUTION

The interlock switches are for the protection of the operator and bystanders and to ensure correct operation of the machine. Do not bypass or disconnect switches. Check the operation of the interlock switches daily for proper operation. Replace any malfunctioning switches before operating the machine.

Interlock switch operation is described in the Traction Unit Operator's Manual. Your Reelmaster is equipped with an Electronic Control Module (ECM) which monitors interlock switch operation. Information on the ECM is described in the Traction Unit Operator's Manual and in the Component Testing section of this Chapter.

The interlock system used on your Reelmaster includes the seat switch, the traction neutral switch, the parking brake switch, the cutting unit up limit switch, the mow/transport switch, the PTO switch and two (2) cutting unit backlap switches. Testing of individual interlock switches is included in the Component Testing section of this Chapter.

NOTE: Use the Diagnostic Display (see Special Tools in this chapter) to test Electronic Control Module inputs and outputs before further troubleshooting of an electrical problem on your Reelmaster.

Adjustments

Traction Neutral Switch

The traction neutral switch is a normally open proximity switch that closes when the traction pedal is in the neutral position. The switch mounts to a bracket on the traction pump. On machines with serial numbers below 310000000 (Fig. 17), the sensing element for the traction neutral switch is a cap screw on the pump control arm. On machines with serial numbers above 310000000 (Fig. 18), the sensing element for the traction neutral switch is the traction lever bracket that is secured to the pump control arm.

Adjustment

1. Before adjusting the traction neutral switch, check and adjust traction system neutral position (see Traction Unit Operator's Manual).

IMPORTANT: To prevent traction neutral switch damage, make sure that no components contact switch through entire pump control arm movement.

2. For machines with serial numbers below 310000000 (Fig. 17), adjust traction neutral switch as follows:

A. Loosen jam nut that secures position of cap screw on pump control arm.

B. Rotate cap screw so clearance exists between head of the screw and neutral switch body but clearance is less than 0.125" (3.2 mm).

C. Torque jam nut from **71 to 89 in-lb (8 to 10 N-m)** to secure adjustment. After jam nut is tightened, make sure that clearance between cap screw head and neutral switch has not changed.

3. For machines with serial numbers above 310000000 (Fig. 18), adjust traction neutral switch as follows:

A. When the traction lever is in the neutral position, the clearance between the head of neutral switch and the traction lever bracket should be from 0.040" to 0.100" (1.1 to 2.5 mm).

B. If clearance is incorrect, loosen jam nuts that secure neutral switch to pump bracket. Position switch with jam nuts to allow correct clearance between switch and traction lever bracket. Jam nuts should be torqued from **162 to 198 in-lb (18.4 to 22.4 N-m)**. After jam nuts are tightened, make sure that clearance has not changed.

4. After adjustment to the traction neutral switch, use the Diagnostic Display (see Special Tools in this chapter) to verify that traction neutral switch and circuit wiring **are** functioning correctly (see Traction Neutral Switch in the Component Testing section of this chapter).

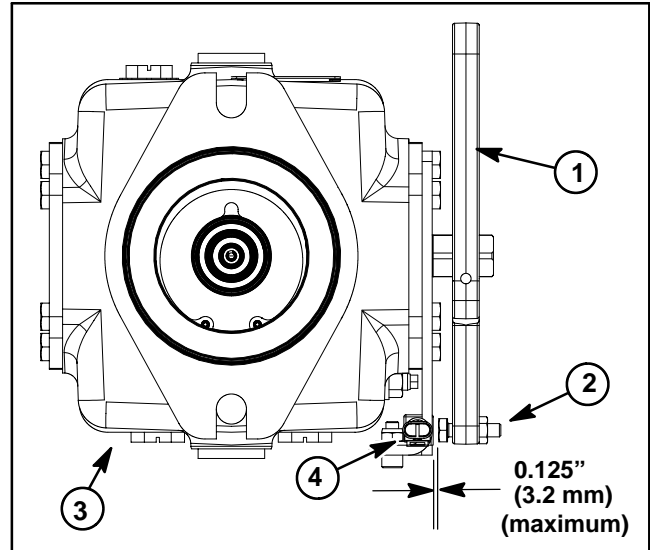

Figure 17

- 1. Pump control arm
- 2. Cap screw / jam nut
- 3. Traction pump
- 4. Traction neutral switch

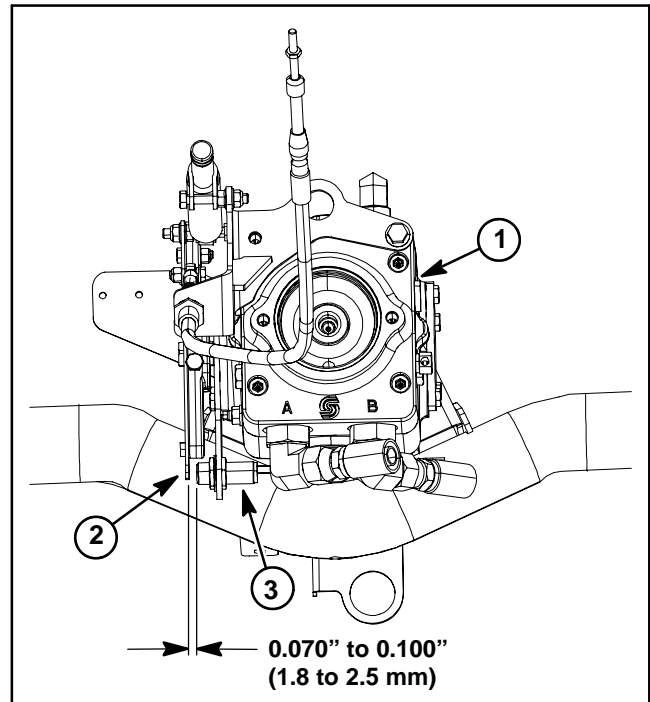

Figure 18

- 1. Traction pump
- 2. Traction lever bracket
- 3. Traction neutral switch

Parking Brake Switch

The parking brake switch is a normally open proximity switch. The parking brake switch is attached to the bottom of the brake pedal (Fig. 19).

When the parking brake is not applied, the parking brake detent is positioned near the target end of the parking brake switch so the switch is closed. The parking brake detent is moved away from the switch when the parking brake is applied causing the switch to open.

Adjustment

For machines with serial numbers below 310000000 (Fig. 19), the distance between the parking brake switch and the tab on the parking brake detent should be from 0.048" to 0.077" (1.2 to 1.9 mm) when the parking brake is not applied. If distance is incorrect, loosen lock nut that secures switch to brake lever. Position switch to allow correct clearance between switch and detent tab. Tighten lock nut to secure adjustment.

For machines with serial numbers above 310000000 (Fig. 20), the distance between the parking brake switch and the tab on the parking brake detent should be from 0.040" to 0.100" (1.1 to 2.5 mm) when the parking brake is not applied. If distance is incorrect, loosen jam nuts that secure brake switch to brake pedal. Position switch with jam nuts to allow correct clearance between switch and brake detent tab. Jam nuts should be torqued from **162 to 198 in-lb (18.4 to 22.4 N-m)**. After jam nuts are tightened, make sure that clearance has not changed.

After adjustment to the parking brake switch, use the Diagnostic Display (see Special Tools in this chapter) to verify that brake switch and circuit wiring **are** functioning correctly (see Parking Brake Switch in the Component Testing section of this chapter).

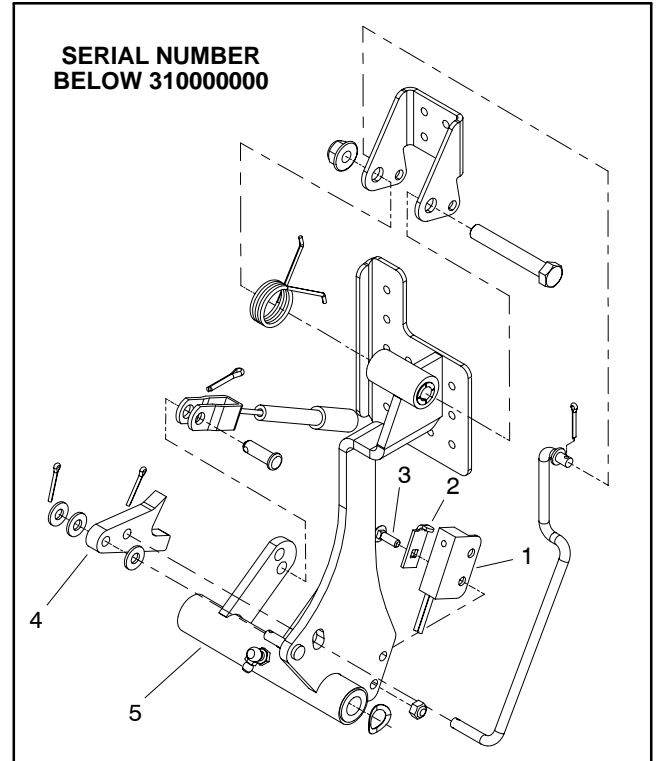

Figure 19

- | | |
|-------------------------|-------------------------|
| 1. Parking brake switch | 4. Parking brake detent |
| 2. Switch plate | 5. Brake pedal |
| 3. Carriage bolt | |

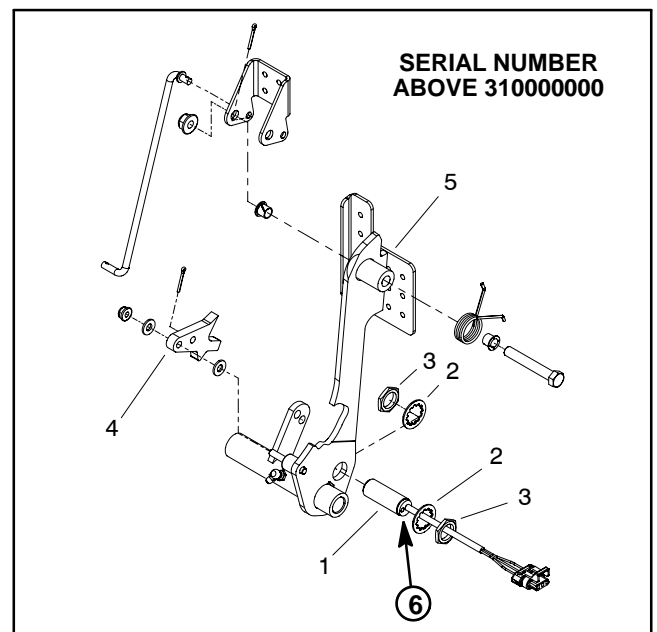

Figure 20

- | | |
|-------------------------|-------------------------|
| 1. Parking brake switch | 4. Parking brake detent |
| 2. Lock washer (2 used) | 5. Brake pedal |
| 3. Jam nut (2 used) | 6. Switch LED location |

Up Limit Switch

The up limit switch is a normally open proximity switch that closes when the cutting units are in the lowered position. A bracket on the front, right lift arm acts as the sensing plate for the up limit switch (Fig. 21).

Adjustment

The up limit switch should be secured to the switch bracket at the midpoint of the bracket mounting slots.

NOTE: The vertical location of the up limit switch on the switch bracket will determine the turn-around position of the front, outside cutting units (cutting units #4 and #5). Raising the switch on the bracket will allow a lower turn-around position of the cutting units. Lowering the switch on the bracket will allow a higher turn-around position of the cutting units.

For machines with serial numbers below 310000000 (Fig. 21), the distance between the up limit switch and sensing plate on lift arm should be from 0.048" to 0.077" (1.2 to 1.9 mm). If distance is incorrect, loosen two (2) lock nuts that secure switch bracket to machine frame. Position bracket to allow correct clearance between switch and sensing plate. Tighten lock nuts to secure adjustment.

For machines with serial numbers above 310000000 (Fig. 22), the distance between the up limit switch and the sensing plate on lift arm should be from 0.040" to 0.100" (1.1 to 2.5 mm). If distance is incorrect, loosen jam nuts that secure up limit switch to machine frame. Position switch with jam nuts to allow correct clearance between switch and sensing plate. Jam nuts should be torqued from **162 to 198 in-lb (18.4 to 22.4 N-m)**. After jam nuts are tightened, make sure that clearance has not changed.

After adjustment to the up limit switch, use the Diagnostic Display (see Special Tools in this chapter) to verify that up limit switch and circuit wiring **are** functioning correctly (see Up Limit Switch in the Component Testing section of this chapter).

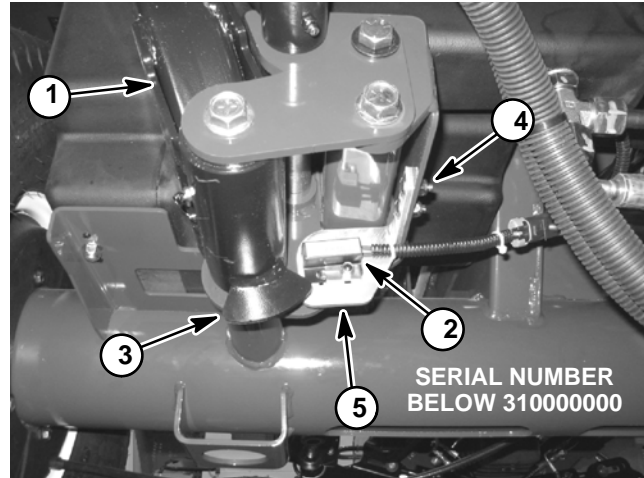

Figure 21

- | | |
|--------------------|----------------------|
| 1. Lift arm | 4. Lock nut (2 used) |
| 2. Up limit switch | 5. Switch bracket |
| 3. Sensing plate | |

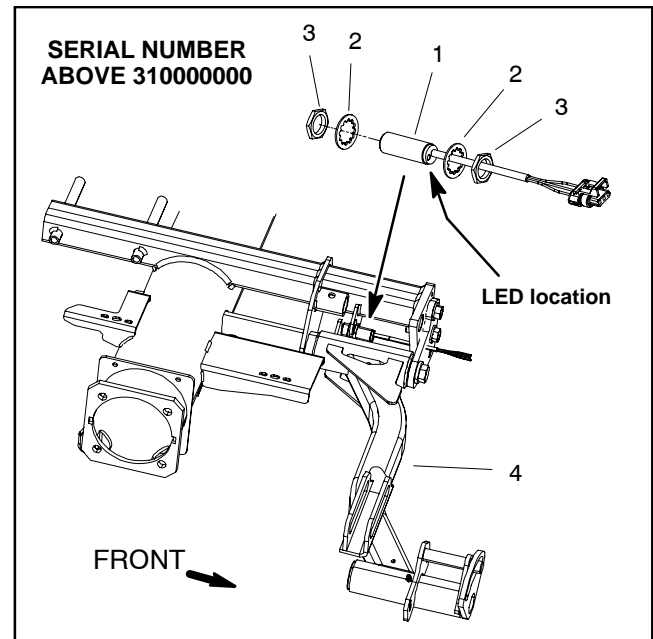

Figure 22

- | | |
|--------------------|-------------|
| 1. Up limit switch | 3. Jam nut |
| 2. Lock washer | 4. Lift arm |

Component Testing

For accurate resistance and/or continuity checks, electrically disconnect the component being tested from the circuit (e.g. unplug the ignition switch connector before doing a continuity check of the switch).

NOTE: Electrical troubleshooting of any 12 volt power connection can be performed through voltage drop tests without disconnecting the component.

NOTE: Use the Diagnostic Display (see Special Tools in this chapter) to test Electronic Control Module inputs and outputs before further troubleshooting of an electrical problem on your Reelmaster.

NOTE: See the Kubota Workshop Manual: 05 Series Engine for additional electrical component repair information.

CAUTION

When testing electrical components for continuity with a multimeter (ohms setting), make sure that power to the circuit has been disconnected.

Ignition Switch

The ignition (key) switch has three positions (OFF, RUN and START). The switch is mounted on the control console.

Testing

1. Before disconnecting the ignition switch for testing, the switch and its circuit wiring should be tested as an ECM input with the Diagnostic Display (see Diagnostic Display in the Troubleshooting section of this chapter).
2. If the Diagnostic Display verifies that ignition switch and circuit wiring **are** functioning correctly, no further switch testing is necessary.
3. If the Diagnostic Display determines that ignition switch and circuit wiring **are not** functioning correctly, test ignition switch as follows:

A. Remove outside control arm cover to gain access to ignition switch (see Control Arm Disassembly in the Service and Repairs section of this chapter). Disconnect harness electrical connector from the switch.

B. With the use of a multimeter (ohms setting), the switch functions may be tested to determine whether continuity exists between the various terminals for each switch position. The ignition switch terminals are marked as shown in Figure 24. The circuitry of this switch is shown in the chart below. Verify continuity between switch terminals.

POSITION	CIRCUIT
OFF	NONE
RUN	B + I + A, X + Y
START	B + I + S

C. Replace ignition switch if necessary.

D. If ignition switch tests correctly and circuit problem still exists, check wire harness (see Wiring Schematic and Circuit Drawings in Chapter 9 - Electrical Diagrams).

E. Connect harness electrical connector to the ignition switch.

F. Install control arm cover to machine (see Control Arm Assembly in the Service and Repairs section of this chapter).

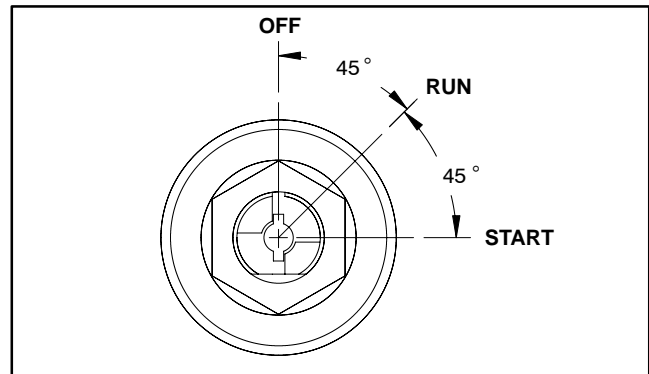

Figure 23

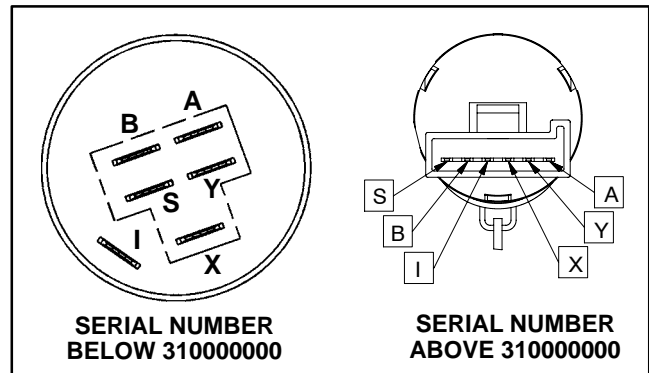

Figure 24

Indicator Lights

Glow Plug Indicator Light

The glow plug indicator light should come on when the ignition switch is placed in the RUN position prior to placing the ignition switch in START. The light should stay lit for approximately 6 seconds while the ignition switch is left in the RUN position. The indicator light should also be illuminated when the ignition switch is in the START position.

High Temperature Warning Light

If the engine coolant temperature reaches 221°F (105°C) (approximate), the high temperature warning light should come on.

NOTE: When machine is in mow operation, high coolant temperature will cause the cutting reels to shut off in addition to warning light illumination.

Engine Oil Pressure Light

The engine oil pressure light should come on when the ignition switch is in the RUN position with the engine not running. Also, it should illuminate with the engine running if the engine oil pressure drops to an unsafe level.

To test the oil pressure light and circuit wiring, ground the wire attached to oil pressure switch located on the engine near the oil filter. Turn ignition switch to the RUN position; the engine oil pressure light should come on indicating correct operation of the indicator light and circuit wiring.

Charge Indicator Light

The charge indicator light should come on when the ignition switch is in the RUN position with the engine not running. Also, it should illuminate with an improperly operating charging circuit while the engine is running.

Testing Indicator Lights

If testing of the indicator lights is necessary:

1. Remove control arm covers to gain access to indicator light and harness connectors (see Control Arm Disassembly in the Service and Repairs section of this chapter).
2. Locate the indicator light to be tested and disconnect the harness electrical connector from the light.
3. Apply 12 VDC to terminals 1A and 2A (Fig. 24).

4. Ground terminals 1B and 2B (Fig. 24).
5. Both indicator lights should illuminate.
6. Connect harness electrical connector to the indicator light.
7. Install control arm cover to machine (see Control Arm Assembly in the Service and Repairs section of this chapter).

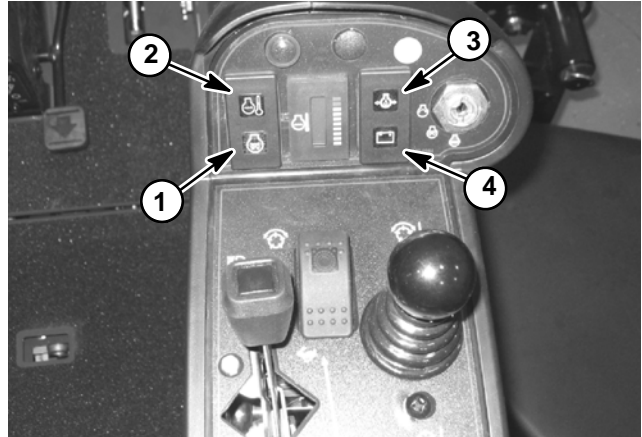

Figure 23

1. Glow plug indicator
2. High temp warning
3. Engine oil pressure
4. Charge indicator

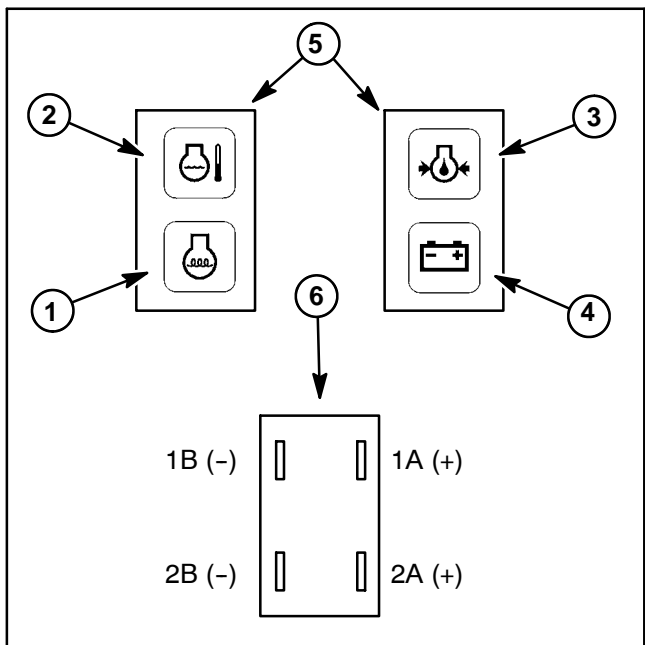

Figure 24

1. Glow plug indicator
2. High temp warning
3. Engine oil pressure
4. Charge indicator
5. Indicator light front
6. Indicator light back

Hour Meter

The hour meter is located on the outside of the control arm.

1. Remove control arm covers to gain access to hour meter and meter terminals (see Control Arm Disassembly in the Service and Repairs section of this chapter).
2. Make sure ignition switch is in the OFF position. Locate the hour meter and disconnect the wire harness electrical connector from the meter.
3. Connect the positive (+) terminal of a 12 VDC source to the positive (+) terminal of the hour meter.
4. Connect the negative (-) terminal of the voltage source to the other terminal of the hour meter.
5. The hour meter should move 1/10 of an hour every six minutes.
6. Disconnect the voltage source from the hour meter.
7. Replace the hour meter if necessary.
8. Connect harness electrical connector to the hour meter.
9. Install control arm covers to machine (see Control Arm Assembly in the Service and Repairs section of this chapter).

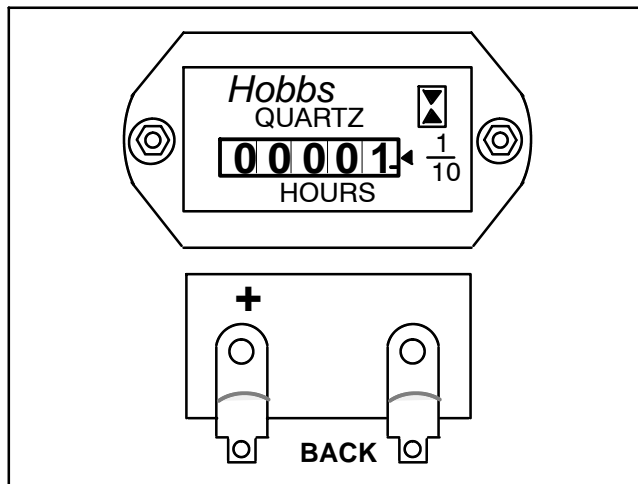

Figure 25

Temperature Gauge

The temperature gauge on the control panel indicates engine coolant temperature level during machine operation. The changing resistance of the engine temperature sender signals the temperature gauge.

The temperature gauge should display the first green segment when the ignition switch is turned to RUN. The first yellow segment on the gauge should display when engine coolant temperature is approximately 212°F (100°C).

When engine coolant temperature rises to approximately 221°F (105°C), the temperature gauge should display the first red segment. At this point, the temperature gauge provides an input to the Electronic Control Module (ECM). This ECM input causes the high temperature warning light on the control panel to illuminate and the cutting reels to shut down.

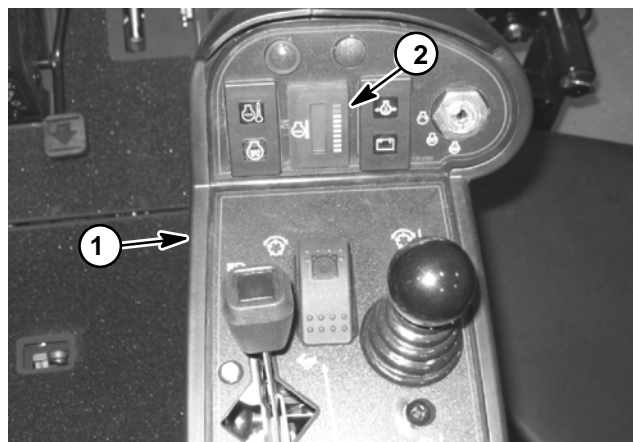

Figure 26

1. Control panel
2. Temperature gauge

PTO Switch

The PTO switch is mounted on the control panel and is pressed to allow the cutting units to operate. An indicator light on the switch identifies when the PTO switch is engaged.

Testing

1. Before disconnecting the switch for testing, the switch and its circuit wiring should be tested as an ECM input with the Diagnostic Display (see Diagnostic Display in the Troubleshooting section of this chapter).
2. If the Diagnostic Display verifies that PTO switch and circuit wiring **are** functioning correctly, no further switch testing is necessary.
3. If the Diagnostic Display determines that PTO switch and circuit wiring **are not** functioning correctly, test PTO switch as follows:

A. Remove control arm covers to gain access to PTO switch (see Control Arm Disassembly in the Service and Repairs section of this chapter).

B. Make sure ignition switch is in the OFF position. Disconnect harness electrical connector from the switch.

C. With the use of a multimeter (ohms setting), the switch functions may be tested to determine whether continuity exists between the various terminals for each switch position. The PTO switch terminals are marked as shown in Figure 28. The circuitry of this switch is shown in the chart below. Verify continuity between switch terminals.

SWITCH POSITION	NORMAL CIRCUITS	OTHER CIRCUITS
ON	2 + 3	5 + 6
OFF	2 + 1	5 + 4

D. Replace switch if necessary.

E. If switch tests correctly and circuit problem still exists, check wire harness (see Wiring Schematic and Circuit Drawings in Chapter 9 - Electrical Diagrams).

F. Connect harness electrical connector to the PTO switch.

G. Install control arm cover to machine (see Control Arm Assembly in the Service and Repairs section of this chapter).

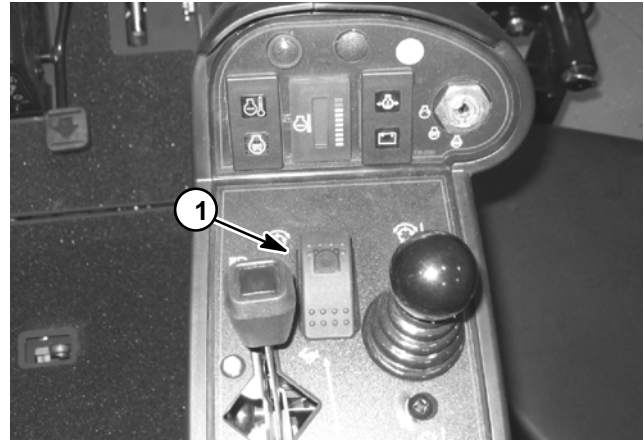
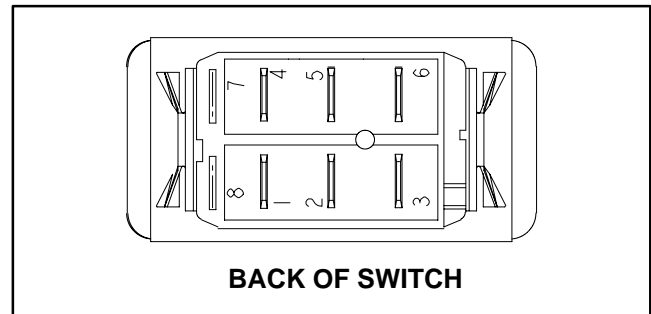

Figure 27

1. PTO switch



BACK OF SWITCH

Figure 28

NOTE: PTO switch terminals 1, 4, 5 and 6 are not used on Reelmaster 5010 machines.

Traction Neutral Switch

The traction neutral switch is a normally open proximity switch that closes when the traction pedal is in the neutral position. The switch mounts to a bracket on the traction pump. On machines with serial numbers below 310000000 (Fig. 31), the sensing element for the traction neutral switch is a cap screw on the pump control arm. On machines with serial numbers above 310000000 (Fig. 32), the sensing element for the traction neutral switch is the traction lever bracket that is secured to the pump control arm.

Testing

1. Before testing the traction neutral switch, the switch and its circuit wiring should be tested as an ECM input with the Diagnostic Display (see Diagnostic Display in the Troubleshooting section of this chapter). If the Diagnostic Display verifies that the traction neutral switch and circuit wiring **are** functioning correctly, no further switch testing is necessary. If the Diagnostic Display determines that the traction neutral switch and circuit wiring **are not** functioning correctly, proceed with testing procedure.

2. Tilt operator seat to gain access to traction neutral switch.

3. On machines with serial numbers below 310000000 (Fig. 31), test neutral switch as follows:

A. Make sure ignition switch is in the OFF position. Disconnect the wire harness electrical connector from the switch and check the continuity of the switch by connecting a multimeter (ohms setting) across the switch connector terminals.

B. There **should be** continuity across the switch terminals when the traction pedal is in the neutral position. There **should not be** continuity when the traction pedal is in either the forward or reverse direction.

4. On machines with serial numbers above 310000000 (Fig. 32), test neutral switch as follows:

A. Turn ignition switch to the ON position (do not start engine) and check LED on cable end of neutral switch. LED **should be** illuminated when the traction pedal is in the neutral position. LED **should not be** illuminated when the traction pedal is in either the forward or reverse position.

5. If the traction neutral switch is faulty, replace switch. Adjust switch after installation (see Traction Neutral Switch in the Adjustments section of this chapter).

6. If the neutral switch tests correctly and a circuit problem still exists, check wire harness (see Wiring Schematic and Circuit Drawings in Chapter 9 - Electrical Diagrams).

7. Make sure that wire harness electrical connector is connected to the traction neutral switch. Lower operator seat.

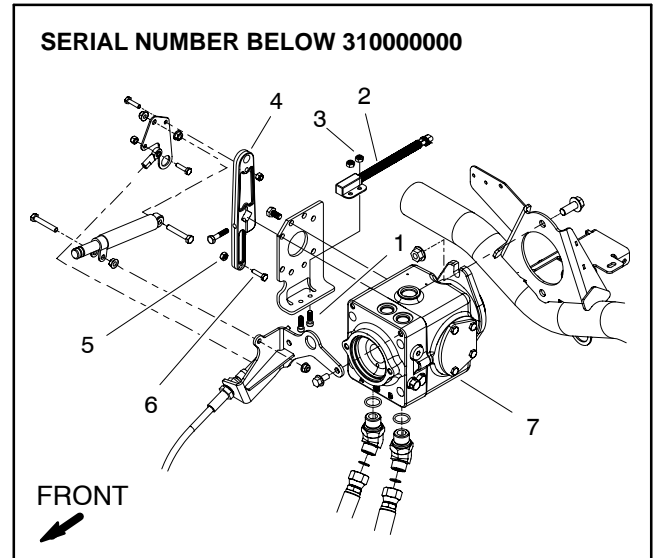

Figure 31

- | | |
|----------------------------|------------------|
| 1. Screw (2 used) | 5. Cap screw |
| 2. Traction neutral switch | 6. Jam nut |
| 3. Lock nut (2 used) | 7. Traction pump |
| 4. Pump control arm | |

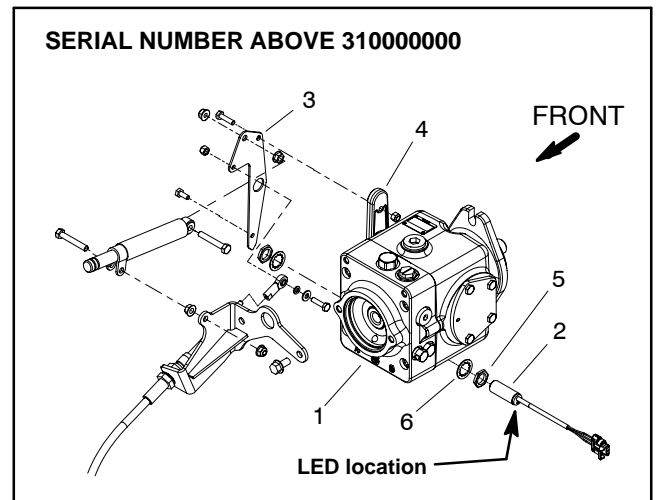

Figure 32

- | | |
|----------------------------|-------------------------|
| 1. Traction pump | 4. Pump control arm |
| 2. Traction neutral switch | 5. Jam nut (2 used) |
| 3. Traction lever bracket | 6. Lock washer (2 used) |

Seat Switch

The seat switch is normally open and closes when the operator seat is occupied. If the traction system or PTO switch is engaged when the operator raises out of the seat, the engine will stop. The seat switch is located directly under the operator seat.

Testing

1. Before disconnecting the seat switch for testing, the switch and its circuit wiring should be tested as an ECM input with the Diagnostic Display (see Diagnostic Display in the Troubleshooting section of this chapter).
2. If the Diagnostic Display verifies that seat switch and circuit wiring **are** functioning correctly, no further switch testing is necessary.
3. If the Diagnostic Display determines that seat switch and circuit wiring **are not** functioning correctly, test seat switch as follows:

- A. Make sure ignition switch is in the OFF position.
- B. Disconnect wire harness electrical connector from the seat switch electrical lead near the manual tube under the operator seat (Fig. 31).
- C. Check the continuity of the switch by connecting a multimeter (ohms setting) across the switch connector terminals.
- D. With no pressure on the seat, there should be no continuity between the seat switch terminals.
- E. Press directly onto the seat switch through the seat cushion. There should be continuity as the seat cushion approaches the bottom of its travel.
- F. If seat switch is faulty, replace switch.
- G. If the seat switch tests correctly and a circuit problem still exists, check wire harness (see Wiring Schematic and Circuit Drawings in Chapter 9 – Electrical Diagrams).
- H. Connect harness electrical connector to the seat switch.

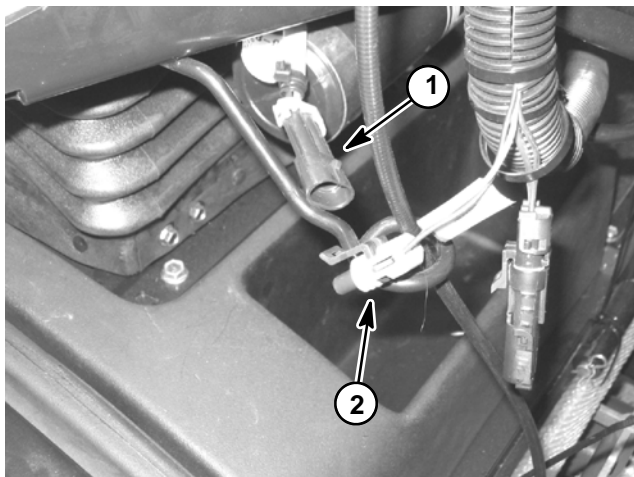

Figure 31

1. Seat switch lead

2. Electrical connector

Headlight Switch

The headlight switch is located on the operator side of the control arm. This rocker switch allows the headlights to be turned on and off.

Testing

1. Remove inside control arm cover to gain access to headlight switch (see Control Arm Disassembly in the Service and Repairs section of this chapter).
2. Make sure ignition switch is in the OFF position. Disconnect harness electrical connector from the switch.
3. With the use of a multimeter (ohms setting), the switch functions may be tested to determine whether continuity exists between the various terminals for each position. The switch terminals are marked as shown in Figure 32. The circuitry of the headlight switch is shown in the chart below. Verify continuity between switch terminals.

SWITCH POSITION	NORMAL CIRCUITS	OTHER CIRCUITS
ON	2 + 3	5 + 6
OFF	2 + 1	5 + 4

4. Replace switch if necessary. Connect harness electrical connector to the headlight switch.
5. Install control arm cover to machine (see Control Arm Assembly in the Service and Repairs section of this chapter).

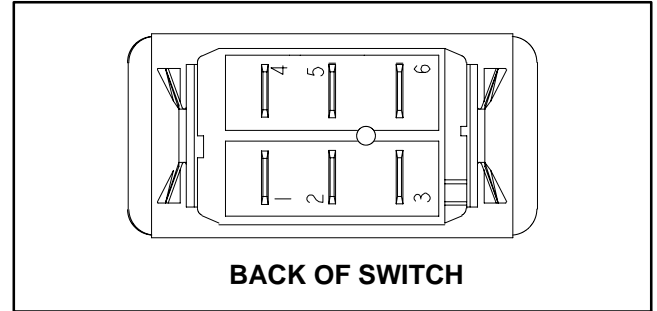

Figure 32

NOTE: Headlight switch terminals 3, 4, 5 and 6 are not used on Reelmaster 5010 machines.

Parking Brake Switch

The parking brake switch is a normally open proximity switch. The parking brake switch is attached to the bottom of the brake pedal. The switch on machines with a serial number below 310000000 is different than the switch on machines with serial numbers above 310000000 but the switch function is the same.

When the parking brake is not applied, the parking brake detent is positioned near the target end of the parking brake switch so the switch is closed. The parking brake detent is moved away from the switch when the parking brake is applied causing the switch to open.

Testing

1. Before testing the parking brake switch, the switch and its circuit wiring should be tested as an ECM input with the Diagnostic Display (see Diagnostic Display in the Troubleshooting section of this chapter). If the Diagnostic Display verifies that the parking brake switch and circuit wiring **are** functioning correctly, no further switch testing is necessary. If the Diagnostic Display determines that the parking brake switch and circuit wiring **are not** functioning correctly, proceed with testing procedure.

2. On machines with serial numbers below 310000000 (Fig. 35), test parking brake switch as follows:

A. Make sure ignition switch is in the OFF position. Disconnect the wire harness electrical connector from the switch. Check the continuity of the switch by connecting a multimeter (ohms setting) across the switch connector terminals.

B. There **should be** continuity (closed) between the switch terminals when the parking brake is released (not applied). There **should not be** continuity (open) between the switch terminals when the parking brake pedal is depressed (applied).

3. On machines with serial numbers above 310000000 (Fig. 36), test parking brake switch as follows:

A. Turn ignition switch to the ON position (do not start engine) and check LED on cable end of parking brake switch. LED **should be** illuminated when the parking brake is released (not applied). LED **should not be** illuminated when the parking brake pedal is depressed (applied).

NOTE: When installing the parking brake switch on machines with serial numbers below 310000000, place switch plate tab into switch mounting hole that is closest to target end of switch.

4. If parking brake switch is faulty, replace switch. Adjust switch after installation (see Parking Brake Switch in the Adjustments section of this chapter).

5. If the parking brake switch tests correctly and a circuit problem still exists, check wire harness (see Wiring Schematic and Circuit Drawings in Chapter 9 - Electrical Diagrams).

6. Make sure that wire harness electrical connector is connected to the parking brake switch after testing.

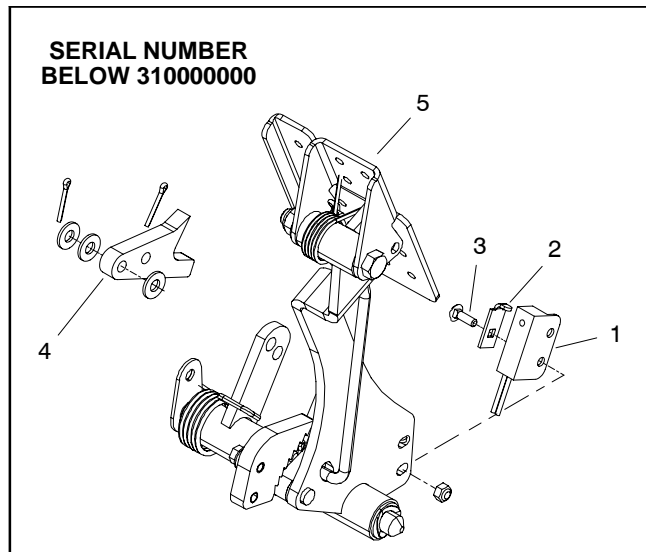

Figure 35

- | | |
|-------------------------|-------------------------|
| 1. Parking brake switch | 4. Parking brake detent |
| 2. Switch plate | 5. Brake pedal |
| 3. Carriage bolt | |

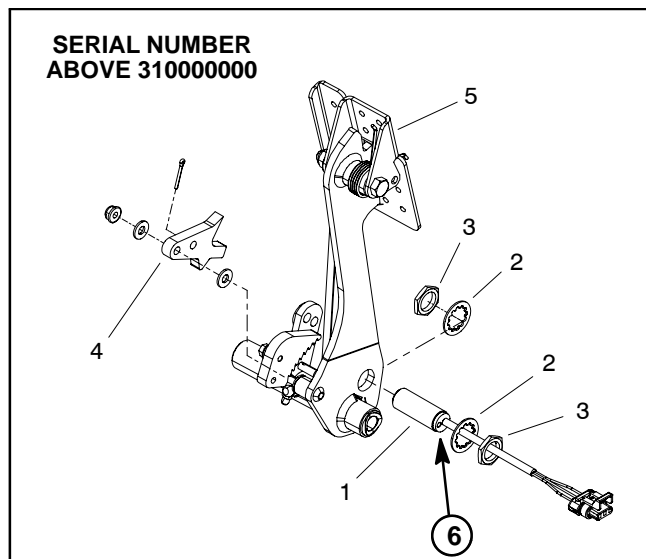

Figure 36

- | | |
|-------------------------|-------------------------|
| 1. Parking brake switch | 4. Parking brake detent |
| 2. Lock washer (2 used) | 5. Brake pedal |
| 3. Jam nut (2 used) | 6. Switch LED location |

Up Limit Switch

The up limit switch is a normally open proximity switch that closes when the cutting units are in the lowered position. A bracket on the front, right lift arm acts as the sensing plate for the up limit switch (Fig. 37). The switch on machines with a serial number below 310000000 is different than the switch on machines with serial numbers above 310000000 but the switch function is the same.

Testing

1. Before testing the up limit switch, the switch and its circuit wiring should be tested as an ECM input with the Diagnostic Display (see Diagnostic Display in the Troubleshooting section of this chapter). If the Diagnostic Display verifies that the up limit switch and circuit wiring **are** functioning correctly, no further switch testing is necessary. If the Diagnostic Display determines that the up limit switch and circuit wiring **are not** functioning correctly, proceed with testing procedure.

2. On machines with serial numbers below 310000000 (Fig. 37), test up limit switch as follows:

A. Make sure ignition switch is in the OFF position. Disconnect the wire harness electrical connector from the switch. Check the continuity of the switch by connecting a multimeter (ohms setting) across the switch connector terminals.

B. There **should be** continuity (closed) between the switch terminals when the cutting units are lowered. Raise the cutting units and check the continuity of the switch. There **should not be** continuity (open) between the switch terminals when the cutting units are raised.

3. On machines with serial numbers above 310000000 (Fig. 38), test up limit switch as follows:

A. Turn ignition switch to the ON position (do not start engine) and check LED on cable end of up limit switch.

B. LED **should be** illuminated when the cutting units are lowered. LED **should not be** illuminated when the cutting units are raised.

NOTE: When installing the up limit switch on machines with serial numbers below 310000000, place switch plate tab into switch mounting hole that is closest to target end of switch.

4. If up limit switch is faulty, replace switch. Adjust switch after installation (see Up Limit Switch in the Adjustments section of this chapter).

5. If the up limit switch tests correctly and a circuit problem still exists, check wire harness (see Wiring Schematic and Circuit Drawings in Chapter 9 - Electrical Diagrams).

6. Make sure that wire harness electrical connector is connected to the up limit switch after testing.

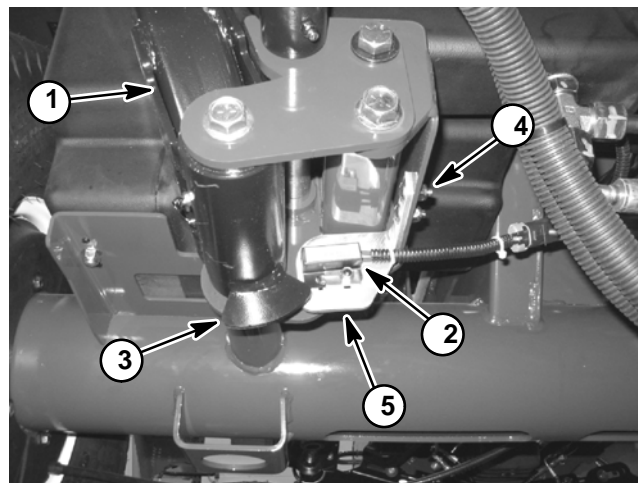

Figure 37

- | | |
|--------------------|----------------------|
| 1. Lift arm | 4. Lock nut (2 used) |
| 2. Up limit switch | 5. Switch bracket |
| 3. Sensing plate | |

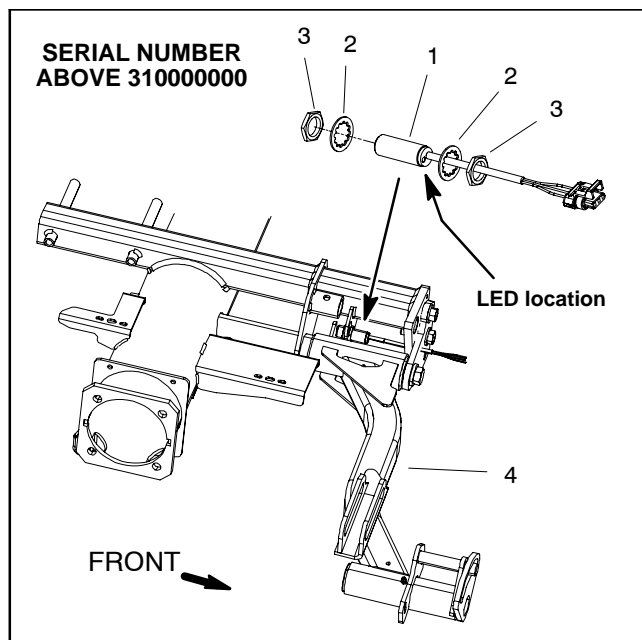

Figure 38

- | | |
|--------------------|-------------|
| 1. Up limit switch | 3. Jam nut |
| 2. Lock washer | 4. Lift arm |

Joystick Raise and Lower Switches

Two micro switches for the joystick are located on the lift control that is attached to the control arm. The rear switch on the control is used to lower (and engage) the cutting units and the front switch to raise (and disengage) them. A normally open contact in the switch closes when the joystick is positioned to either lower or raise the cutting units. Each switch has an electrical connector to make sure the normally closed contact on the switch is not used. The raise switch has yellow/black and black harness wires connected to it and the lower switch has orange and black harness wires connected to it.

Testing

1. Before disconnecting the joystick switches for testing, the switches and their circuit wiring should be tested as an ECM input with the Diagnostic Display (see Diagnostic Display in the Troubleshooting section of this chapter).
2. If the Diagnostic Display verifies that the joystick switches and circuit wiring **are** functioning correctly, no further switch testing is necessary.
3. If the Diagnostic Display determines that either joystick switch and circuit wiring **are not** functioning correctly, test joystick switches as follows:

A. Remove control arm covers to gain access to joystick switches (see Control Arm Disassembly in the Service and Repairs section of this chapter).

B. Make sure ignition switch is in the OFF position.

C. Disconnect harness electrical connector from the raise or lower switch that is to be tested (Fig. 39).

D. Connect a multimeter (ohms setting) across the normally open (NO) and common terminals of the switch (Fig. 40).

E. With the joystick in the neutral (center) position, there should be no continuity across the switch terminals.

F. Move and hold the joystick to activate the switch being tested. There should be continuity across the switch terminals.

G. If joystick switch is faulty, replace switch.

H. If the joystick switch tests correctly and a circuit problem still exists, check wire harness (see Wiring Schematic and Circuit Drawings in Chapter 9 – Electrical Diagrams).

I. Connect harness electrical connector to the joystick switch.

J. Install control arm covers to machine (see Control Arm Assembly in the Service and Repairs section of this chapter).

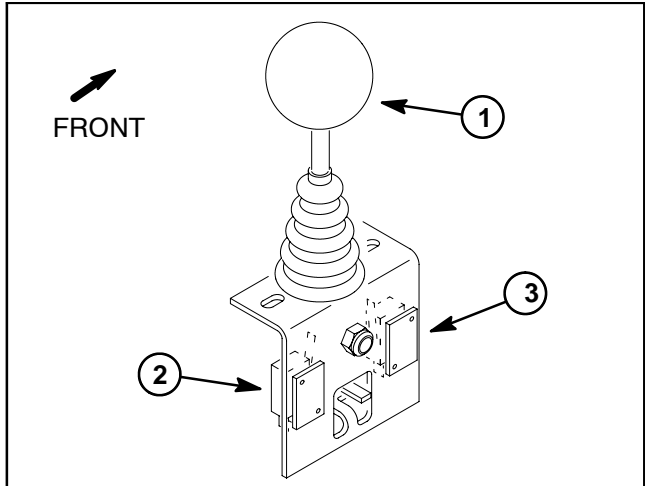

Figure 39

- | | |
|-----------------|-----------------|
| 1. Joystick | 3. Raise switch |
| 2. Lower switch | |

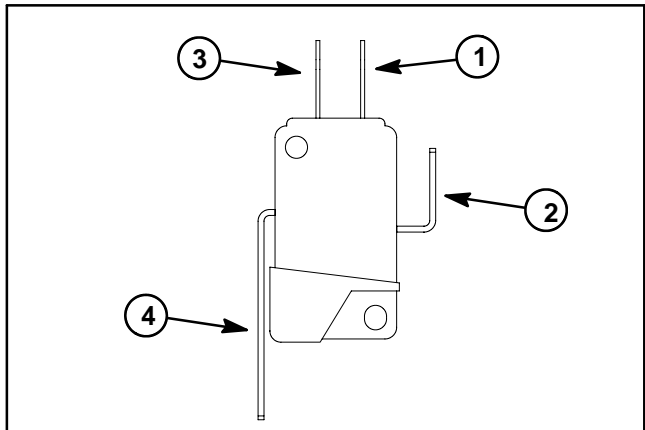

Figure 40

- | | |
|--------------------|---------------------------|
| 1. NO terminal | 3. NC terminal (not used) |
| 2. Common terminal | 4. Switch lever |

Mow/Transport Switch

The mow/transport switch is a normally closed proximity switch that opens when the mow stop lever is placed in the transport position. The sensing plate for the mow/transport switch is the mow stop lever. The switch on machines with a serial number below 310000000 is different than the switch on machines with serial numbers above 310000000 but the switch function is the same.

Testing

1. Before disconnecting the mow/transport switch for testing, the switch and its circuit wiring should be tested as an ECM input with the Diagnostic Display (see Diagnostic Display in the Troubleshooting section of this chapter). If the Diagnostic Display verifies that the mow/transport switch and circuit wiring **are** functioning correctly, no further switch testing is necessary. If the Diagnostic Display determines that the mow/transport switch and circuit wiring **are not** functioning correctly, proceed with testing procedure.

2. On machines with serial numbers below 310000000 (Fig. 41), test mow/transport switch as follows:

A. Make sure ignition switch is in the OFF position. Disconnect the wire harness electrical connector from the switch. Check the continuity of the switch by connecting a multimeter (ohms setting) across the switch connector terminals.

B. There **should be** continuity (closed) between the switch terminals when the mow stop lever is in the mow position. There **should not be** continuity (open) between the switch terminals when the mow stop lever is in the transport position.

3. On machines with serial numbers above 310000000 (Fig. 42), test mow/transport switch as follows:

A. Turn ignition switch to the ON position (do not start engine) and check LED on cable end of mow/transport switch.

B. LED **should be** illuminated when the mow stop lever is in the mow position. LED **should not be** illuminated when the mow stop lever is in the transport position.

C. The distance between the mow/transport switch and the mow/transport lever should be from 0.040" to 0.100" (1.1 to 2.5 mm). If distance is incorrect, loosen jam nuts that secure switch to machine frame. Position switch with jam nuts to allow correct clearance between switch and lever. Jam nuts should be torqued from **162 to 198 in-lb (18.4 to 22.4 N-m)**. After jam nuts are tightened, make sure that clearance has not changed.

NOTE: When installing the mow/transport switch on machines with serial numbers below 310000000, place switch plate tab into switch mounting hole that is closest to target end of switch.

4. If mow/transport switch is faulty, replace switch.
5. If the mow/transport switch tests correctly and a circuit problem still exists, check wire harness (see Wiring Schematic and Circuit Drawings in Chapter 9 - Electrical Diagrams).
6. Make sure that wire harness electrical connector is connected to the mow/transport switch after testing.

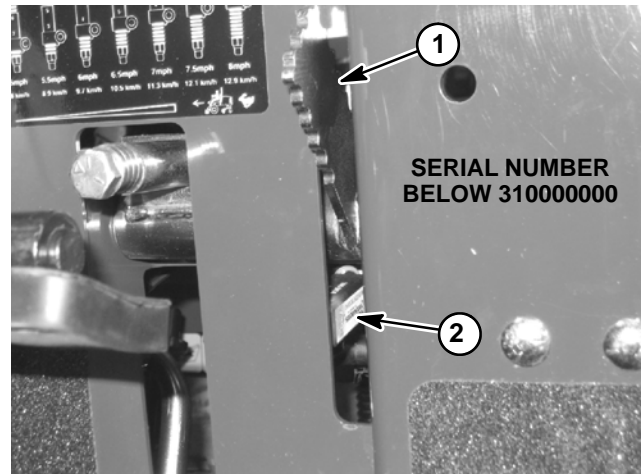

Figure 41

1. Mow stop lever
2. Mow/transport switch

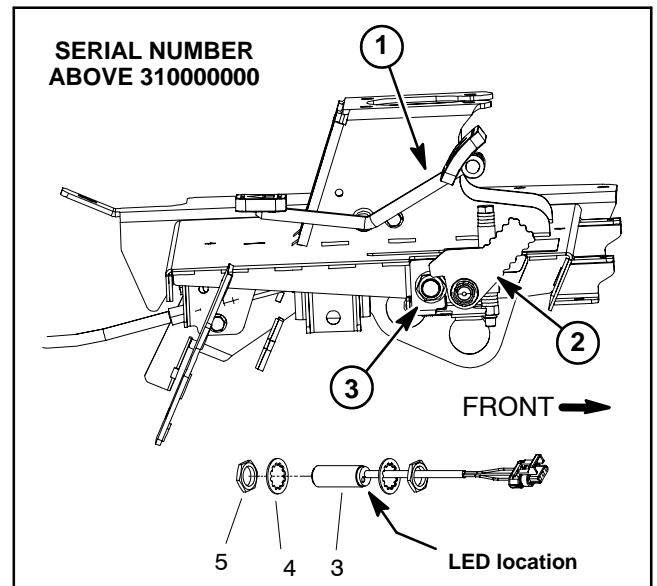

Figure 42

1. Traction pedal
2. Mow/transport lever
3. Mow/transport switch
4. Lock washer (2 used)
5. Jam nut (2 used)

Backlap Switches

The front and rear backlap switches are normally closed ball switches that are in the normal, closed state when the backlap lever is in the backlap position. When the backlap lever is in the mow position, the switch opens. The backlap switches are attached to the hydraulic mow control manifold located under the seat (Fig. 38). The Electronic Control Module uses the backlap switches as inputs to allow only one person to backlap any of the reels and also to prevent the cutting reels from raising during backlapping.

Testing

1. Before disconnecting the backlap switch for testing, the switch and its circuit wiring should be tested as an ECM input with the Diagnostic Display (see Diagnostic Display in the Troubleshooting section of this chapter).

2. If the Diagnostic Display verifies that backlap switch and circuit wiring **are** functioning correctly, no further switch testing is necessary.

3. If the Diagnostic Display determines that backlap switch and circuit wiring **are not** functioning correctly, test backlap switch as follows:

A. Make sure ignition switch is in the OFF position.

B. Tilt operator seat to gain access to backlap switch. Locate the backlap switch on hydraulic mow control manifold. Disconnect the harness electrical connector from the backlap switch.

C. Check the continuity of the switch by connecting a multimeter (ohms setting) across the switch connector terminals.

D. With the ignition switch in the OFF position, turn the backlap lever to the backlap position while watching the multimeter. Continuity should be made as the switch closes.

E. Turn the backlap lever to the mow position while watching the multimeter. Continuity should be broken as the switch opens.

F. If backlap switch is faulty, replace switch.

G. If the neutral switch tests correctly and a circuit problem still exists, check wire harness (see Wiring Schematic and Circuit Drawings in Chapter 9 - Electrical Diagrams).

H. Connect harness electrical connector to the backlap switch. Lower operator seat.

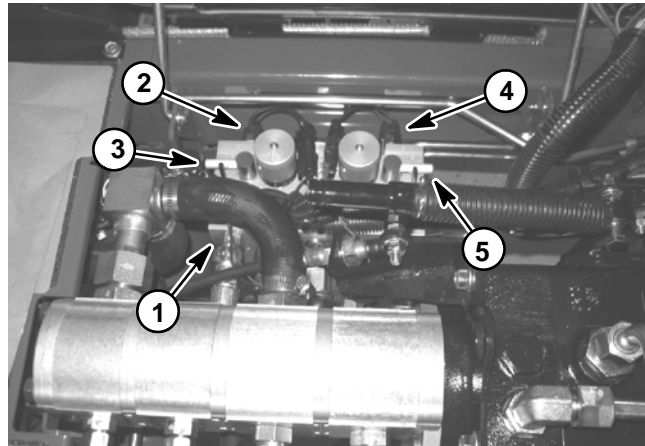

Figure 38

- | | |
|-------------------------|------------------------|
| 1. Mow manifold | 4. Rear backlap switch |
| 2. Front backlap switch | 5. Rear backlap lever |
| 3. Front backlap lever | |

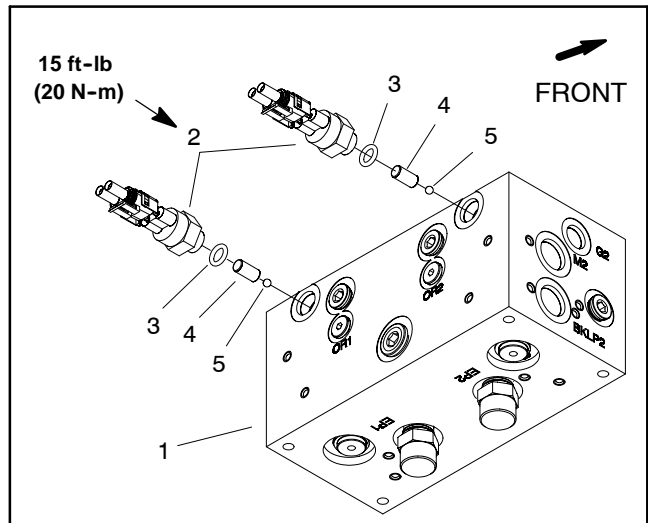

Figure 39

- | | |
|-------------------|--------------|
| 1. Mow manifold | 4. Dowel pin |
| 2. Backlap switch | 5. Ball |
| 3. O-ring | |

Start Relay

The start relay is used in the engine starting circuit. When energized by the Electronic Control Module (ECM), the start relay provides a current path to energize the engine starter solenoid. The start relay is attached to a frame bracket under the hood next to the hydraulic pump drive shaft (Fig. 45).

The ECM controls and monitors the operation of the start relay. The relay and its circuit wiring **should** be tested as an ECM output with the Diagnostic Display before disconnecting and testing the relay (see Diagnostic Display in the Troubleshooting section of this chapter). If the ECM has detected a malfunction in the start relay circuit, the Diagnostic light can be used to identify the fault (see Diagnostic Light in the Troubleshooting section of this chapter).

Testing

1. Before disconnecting the start relay for testing, test relay and its circuit wiring as an ECM output with the Diagnostic Display (see Diagnostic Display in the Troubleshooting section of this chapter). If the Diagnostic Display verifies that the relay and circuit wiring **are** functioning correctly, no further relay testing is necessary.

2. If the Diagnostic Display determines that start relay and circuit wiring **are not** functioning correctly, park machine on a level surface, lower cutting units, stop engine, apply parking brake and remove key from ignition switch. Open hood to gain access to relay.

3. Locate start relay and disconnect the machine wire harness connector from the relay. Remove relay from machine for easier testing.

NOTE: Prior to taking small resistance readings with a digital multimeter, short the meter test leads together. The meter will display a small resistance value (usually 0.5 ohms or less). This resistance is due to the internal resistance of the meter and test leads. Subtract this value from the measured value of the component you are testing.

4. Using a multimeter (ohms setting), measure coil resistance between terminals 85 and 86 (Fig. 46). Resistance should be between 70 and 90 ohms.

5. Connect multimeter (ohms setting) leads to relay terminals 30 and 87. Ground terminal 86 and apply +12 VDC to terminal 85. The relay should have continuity between terminals 30 and 87 as +12 VDC is applied to terminal 85. The relay should not have continuity between terminals 30 and 87 as +12 VDC is removed from terminal 85.

6. Disconnect voltage from terminal 85 and multimeter lead from terminal 87.

7. Connect multimeter (ohms setting) leads to relay terminals 30 and 87A. Apply +12 VDC to terminal 85. The relay should not have continuity between terminals 30 and 87A as +12 VDC is applied to terminal 85. The relay should have continuity between terminals 30 and 87A as +12 VDC is removed from terminal 85.

8. Disconnect voltage and multimeter leads from the relay terminals.

9. Secure relay to machine and connect machine wire harness connector to relay.

10. Lower and secure hood.

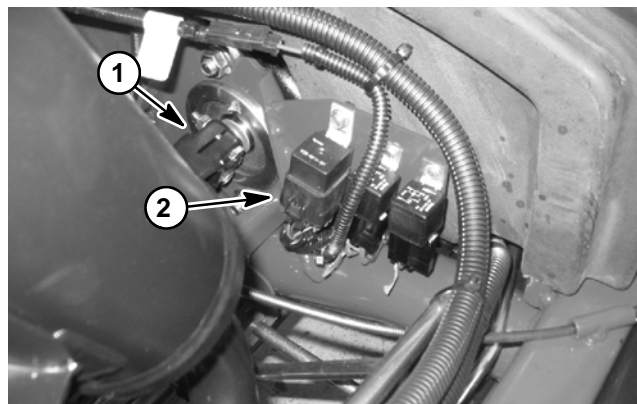

Figure 45

1. Pump drive shaft

2. Start relay

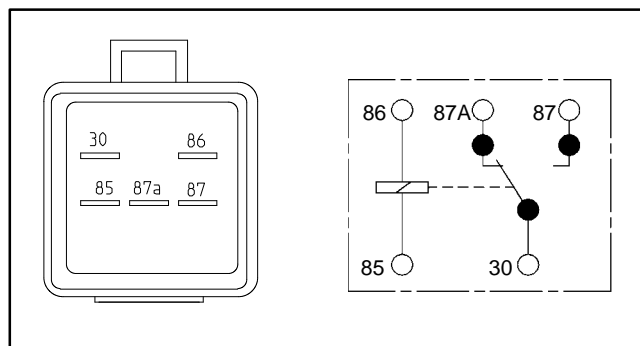

Figure 46

Main Power and Glow Relays

The Reelmaster electrical system includes two identical relays for current control. The main power and glow relays are attached to a frame bracket under the hood next to the hydraulic pump drive shaft (Fig. 42). Relays can be identified by a tag on the wire harness.

The main power relay is used to provide current to the Electronic Control Module (ECM), headlights, power point and optional electric equipment. When the ignition switch is in the RUN or START position, the main power relay is energized.

The glow relay is used to provide current to the engine glow plugs when energized by the ECM. The ECM controls and monitors the operation of the glow relay. The glow relay and its circuit wiring **should** be tested as an ECM output with the Diagnostic Display before disconnecting and testing the relay (see Special Tools and Troubleshooting in this chapter).

Testing

1. Park machine on a level surface, lower cutting units, stop engine, apply parking brake and remove key from ignition switch.
2. Open hood to gain access to relay.
3. Locate relay and disconnect the machine wire harness connector from the relay. Remove relay from machine for easier testing.

NOTE: Prior to taking small resistance readings with a digital multimeter, short the meter test leads together. The meter will display a small resistance value (usually 0.5 ohms or less). This resistance is due to the internal resistance of the meter and test leads. Subtract this value from the measured value of the component you are testing.

4. Verify coil resistance between terminals 85 and 86 with a multimeter (ohms setting) (Fig. 43). Resistance should be approximately 72 ohms.
5. Connect multimeter (ohms setting) leads to relay terminals 30 and 87. Ground terminal 86 and apply +12 VDC to terminal 85. The relay should have continuity between terminals 30 and 87 as +12 VDC is applied to terminal 85. The relay should not have continuity between terminals 30 and 87 as +12 VDC is removed from terminal 85.

6. Disconnect voltage and test leads from the relay terminals.
7. Secure relay to machine and connect machine wire harness connector to relay.
8. Lower and secure hood.

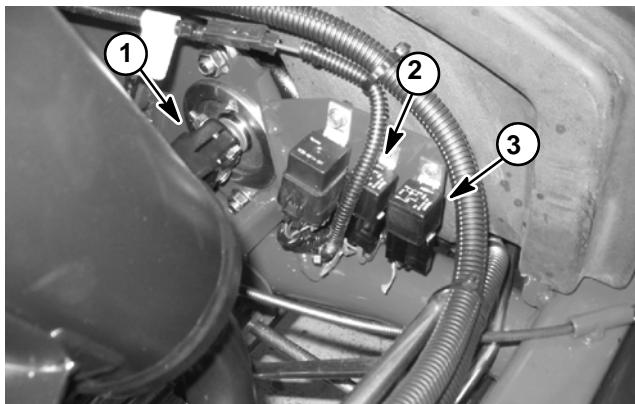

Figure 42

1. Pump drive shaft
2. Main power relay
3. Glow relay

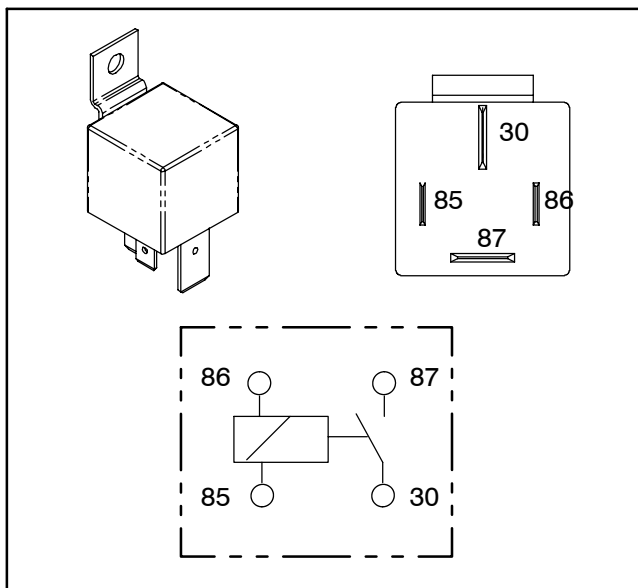

Figure 43

Electronic Control Module (ECM)

The Toro Electronic Control Module (ECM) senses the condition of various switches (inputs) and directs power output to allow certain machine functions. The ECM is located behind the control arm access cover next to the fuse block (Fig. 49). The handheld Diagnostic Display (see Special Tools in this chapter) with the correct overlay should be used when checking inputs and outputs of the ECM used on your Reelmaster (see Troubleshooting in this chapter).

Inputs from the ignition, neutral, parking brake, PTO, seat, cutting unit backlap, mow/transport, joystick lower/raise, cutting unit up limit, temperature gauge output, engine oil pressure and engine high temperature shutdown switches are all monitored by the ECM.

Current output to the mow circuit hydraulic valve solenoid coils, lift circuit hydraulic valve solenoid coils, diagnostic light and engine components (glow plug relay, start relay, fuel pump and engine run solenoid) are controlled based on the inputs received by the ECM.

If the ECM detects a malfunction in any of the controlled circuits, the Diagnostic light can be used to identify the fault (see Diagnostic Light in the Troubleshooting section of this chapter).

Because of the solid state circuitry built into the Electronic Control Module, there is no method to test it directly. The ECM may be damaged if an attempt is made to test it with an electrical test device, such as a digital multimeter.

IMPORTANT: Before performing welding on the machine, disconnect both positive and negative battery cables from the battery, disconnect both wire harness connectors from the Electronic Control Module and disconnect the terminal connector from the alternator to prevent damage to the electrical system.



Figure 49

1. ECM
2. Fuse block

CAN-bus Termination Resistors (Machine With Serial Number Above 28000000)

On Reelmaster machines with a serial number above 280000000, system communication between the leak detector system (if equipped) and the Toro Electronic Control Module (ECM) is accomplished on a CAN-bus communication system. Two (2) specially designed, twisted cables form the bus for the electrical system. These wires provide the data pathways between machine components. At the ends of the twisted pair of bus cables are 120 ohm termination resistors.

One of the termination resistors plugs into the seat wire harness near the joystick control and the other resistor plugs into the main wire harness near the leak detector connector. The insulator wedge in the termination resistor is blue for identification purposes and there also is a center keyway for installation orientation.

NOTE: Refer to the Electrical Schematics and Wire Harness Drawings in Chapter 9 - Foldout Drawings for additional information on termination resistor locations and wire connections.

Reelmaster 5010 Series

Resistor Test

The termination resistors (Fig. 50) can be individually tested using a digital multimeter (ohms setting). There should be 120 ohms resistance between terminals A and B. Terminal C is not used on Reelmaster machines.

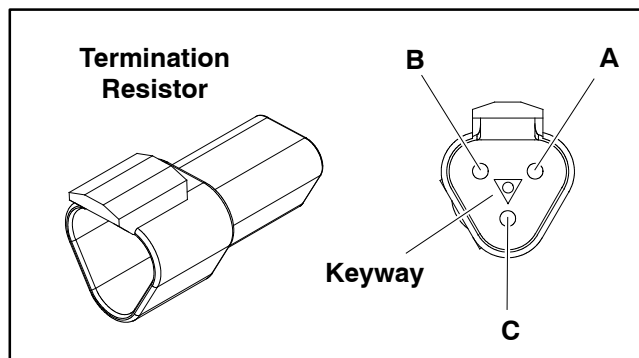

Figure 50

Diode Assembly

A diode assembly (Fig. 51) is used in the Reelmaster engine wire harness (see wire harness drawings in Chapter 9 - Electrical Diagrams). The diode is used for circuit protection from voltage spikes that occur when the starter solenoid is de-energized.

Testing

Locate diode assembly and remove cable tie that secures diode to wire harness. Unplug the diode from the wire harness for testing. The diode (Fig. 52) can be tested using a digital multimeter (diode test or ohms setting) and the table below. After testing is complete, make sure that diode is fully installed into harness connector and secured to harness with cable tie.

Multimeter Red Lead (+) on Terminal	Multimeter Black Lead (-) on Terminal	Continuity
Female	Male	YES
Male	Female	NO

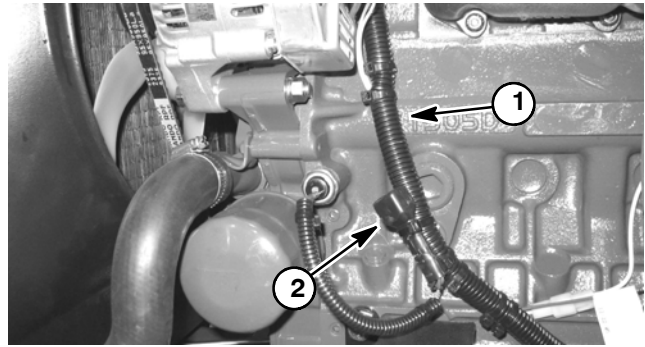

Figure 51

1. Engine wire harness 2. Diode assembly

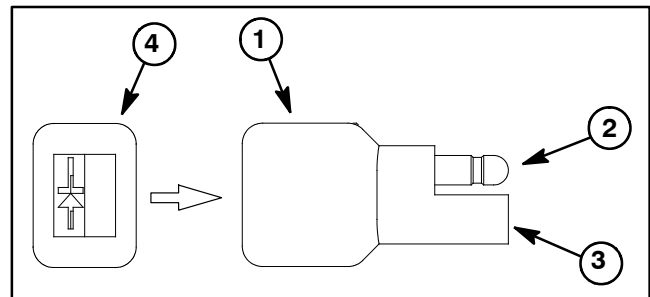

Figure 52

1. Diode 2. Male terminal
3. Female terminal 4. End of diode body

Fusible Link Harness

The Reelmaster uses three (3) fusible links for circuit protection. These fusible links are located in a harness that connects the starter B+ terminal to the main wire harness (Fig. 53). If any of these links should fail, current to the protected circuit will cease. Refer to wire harness drawings in Chapter 9 - Electrical Diagrams for additional fusible link information.

Testing

Make sure that ignition switch is OFF and disconnect negative battery cable from battery terminal. Then disconnect positive cable from battery (see Battery Service in the Service and Repairs section of this chapter). Locate and unplug fusible link connector P1 from machine wire harness. Use a multimeter to make sure that continuity exists between each terminal pin in connector P1 and connector J1 at the starter (Fig. 54). If any of the fusible links are open, replace the fusible link harness.

After testing is complete, make sure that fusible link harness connectors are securely attached to starter and machine wire harness. Connect positive battery cable to battery terminal first and then connect negative cable to battery.

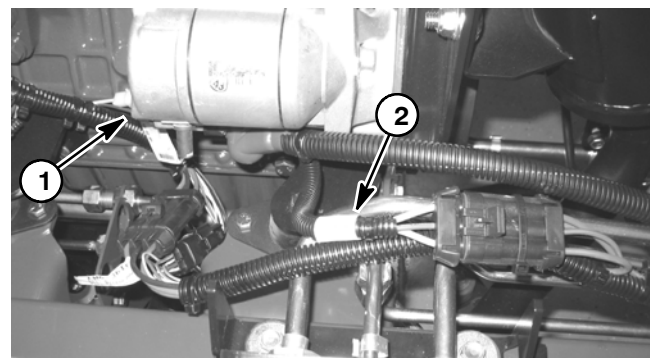

Figure 53

1. Starter motor 2. Fusible link harness

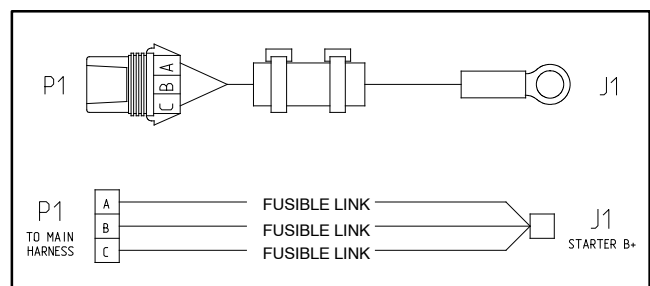

Figure 54

Fuses

The fuse block is located behind the control arm access cover (Fig. 49).

Identification and Function

The fuses are held in the fuse block. Use Figure 50 to identify each individual fuse and its correct amperage. Fuses for your Reelmaster have the following function:

Left Fuse 1 (15 Amp): Protects starter circuit power supply.

Left Fuse 2 (10 Amp): Protects main power supply.

Left Fuse 3 (10 Amp): Protects power supply for headlights.

Left Fuse 4 (10 Amp): Protects power supply for power point.

Right Fuse 1 (10 Amp): Protects power supply for ECM outputs.

Right Fuse 2 (10 Amp): Protects power supply for ECM outputs.

Right Fuse 3 (10 Amp): Protects power supply for ECM outputs.

Right Fuse 4 (2 Amp): Protects power supply for ECM logic.

Testing

Remove fuses from the fuse block for testing. Fuse should have continuity between fuse terminals.

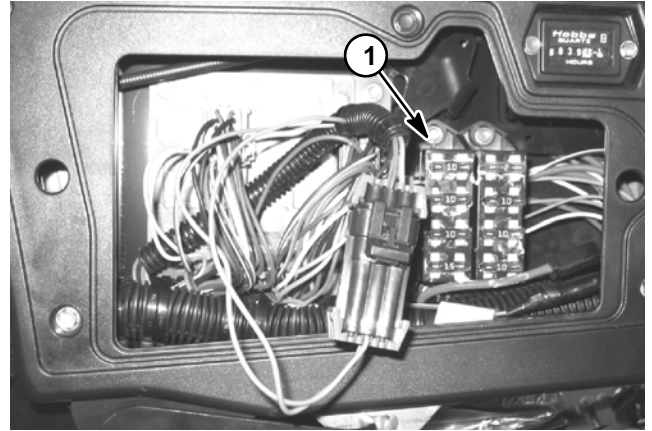

Figure 49

1. Fuse block

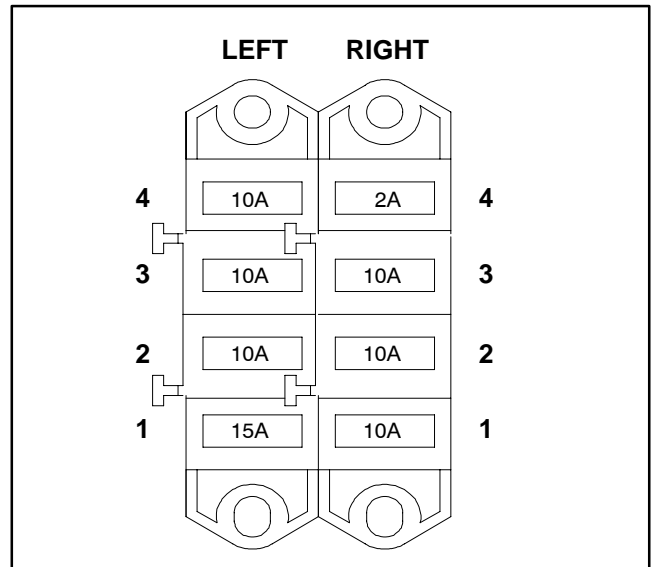

Figure 50

Hydraulic Solenoid Valve Coil

The Reelmaster hydraulic system uses several hydraulic solenoid valve coils for system control. The cutting deck manifold includes two (2) solenoid valves (Fig. 58) and the lift control manifold includes four (4) solenoid valves (Fig. 57). When the solenoid coils are energized, hydraulic valve shift occurs to control hydraulic flow. Testing of the coils can be done with the coil installed on the hydraulic valve.

Testing

1. Before disconnecting solenoid valve coils, test the solenoids and their circuit wiring as ECM outputs with the Diagnostic Display (see Diagnostic Display in the Troubleshooting section of this chapter). If the Diagnostic Display verifies that solenoid coils and circuit wiring **are** functioning correctly, no further testing is necessary.
2. If the Diagnostic Display determines that coils and circuit wiring **are not** functioning correctly, park machine on level surface, lower cutting units, stop engine, apply parking brake and remove key from ignition switch.
3. To gain access to cutting unit control manifold (Fig. 58), raise and prop the operator seat. Access to the lift control manifold (Fig. 57) can be obtained by removing the operator floor plate.
4. Disconnect harness electrical connector from hydraulic solenoid valve coil that is to be tested (Fig. 57 or 58).

NOTE: Prior to taking small resistance readings with a digital multimeter, short the meter test leads together. The meter may display a small resistance value (usually 0.5 ohms or less). This resistance is due to the internal resistance of the meter and test leads. Subtract this value from the measured value of the component you are testing.

5. Using a multimeter (ohms setting), measure resistance between the two connector terminals on the solenoid valve coil. The resistance for the solenoid coils is identified below:

Solenoid Valve Coil	Resistance
MSV1 and MSV2	7.1 ohms
SV1 and SV3	8.7 ohms
SV2 and SVRV	7.1 ohms

6. If solenoid coil resistance is incorrect, replace solenoid (see Hydraulic Solenoid Valve Coil Removal and Installation in the Service and Repairs section of this chapter).

NOTE: The two solenoid valve coils on the mow control manifold (MSV1 and MSV2) are identical. Solenoid valve coils SV2 and SVRV on the lift control manifold are identical and are the same as those used on the mow manifold. The remaining two lift manifold coils (SV1 and SV3) are identical. To assist in troubleshooting, identical coils can be exchanged. If the problem follows the exchanged coil, an electrical problem likely exists. If the problem remains unchanged, something other than the solenoid coil is the problem source (e.g. switch, circuit wiring, hydraulic problem).

7. Connect harness electrical connector to the solenoid valve coil.
8. Lower and secure seat if cutting unit control manifold was accessed. Install operator floor plate if lift control manifold was accessed.

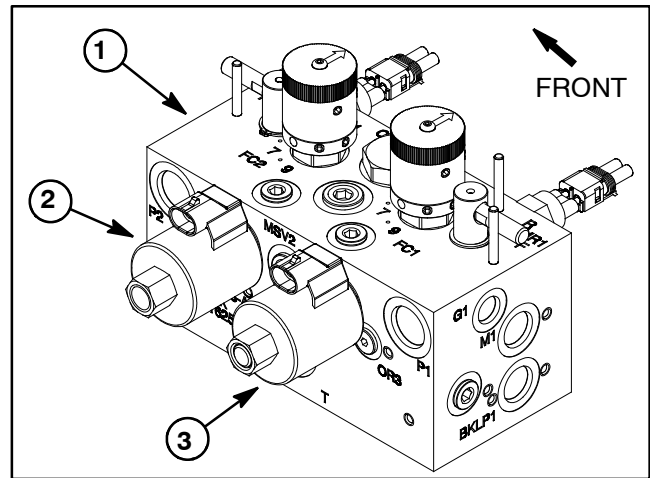

Figure 57

1. Cutting unit manifold
2. MSV2 solenoid
3. MSV1 solenoid

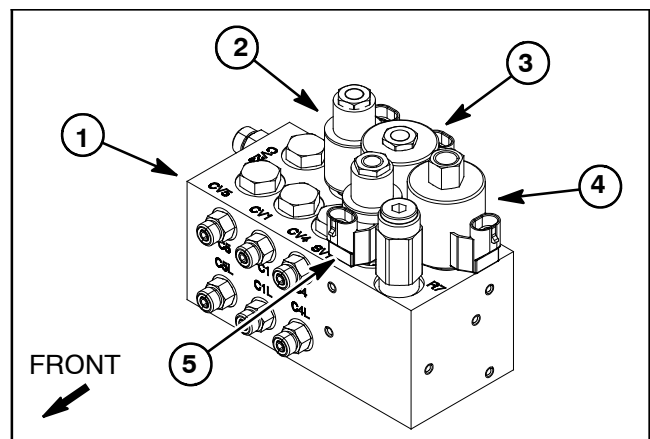

Figure 58

1. Lift manifold
2. SV3 solenoid
3. SV2 solenoid
4. SVRV solenoid
5. SV1 solenoid

Temperature Sender

The temperature sender is attached to the water pump housing on the engine and has a gray wire attached to it (Fig. 53). The resistance of the temperature sender reduces as the engine coolant temperature increases.

The changing resistance of the temperature sender signals the console temperature gauge to indicate engine coolant temperature level during machine operation. When coolant temperature rises to approximately 221°F (105°C), temperature sender resistance causes the temperature gauge to provide an input to the Electronic Control Module (ECM). This ECM input causes the high temperature warning light to illuminate and the cutting reels to shut down. The temperature gauge, temperature sender and circuit wiring **should** be tested as an ECM input with the Diagnostic Display (see Special Tools and Troubleshooting in this chapter).

If the excessive coolant temperature caused the ECM to shut down the cutting reels, the Diagnostic light can be used to identify the fault (see Diagnostic Light in the Troubleshooting section of this chapter).

Testing

1. Park machine on a level surface, lower cutting units, stop engine, apply parking brake and remove key from ignition switch. Open hood to gain access to engine.



CAUTION

Make sure engine is cool before removing the temperature sender from engine.

2. Lower the coolant level in the engine, remove wire harness connector from temperature sender and remove the sender from the engine.

3. Put the end of the sender in a container of oil with a thermometer and slowly heat the oil (Fig. 54).



CAUTION

Handle the hot oil with extreme care to prevent personal injury or fire.

NOTE: Prior to taking resistance readings with a digital multimeter, short the meter test leads together. The meter will display a small resistance value (usually 0.5 ohms or less). This resistance is due to the internal resistance of the meter and test leads. Subtract this value from the measured value of the component you are testing.

4. Check resistance of the sender with a multimeter (ohms setting) as the temperature increases. Replace sender if specifications are not met.

COOLANT TEMP	TEMP SENDER RESISTANCE
100°F (38°C)	460 ohms (approximate)
160°F (71°C)	140 ohms (approximate)
200°F (93°C)	54 to 78 ohms
221°F (105°C)	50 ohms (approximate)

5. After testing, install sender to the engine housing.
 - A. Clean threads of housing and sender thoroughly. Apply thread sealant to the threads of the sender.
 - B. Thread sender into the housing. Torque sender from **16 to 20 ft-lb (22 to 27 N-m)**.
 - C. Reconnect harness wire connector to sender.
6. Fill engine cooling system.
7. Lower and secure hood.

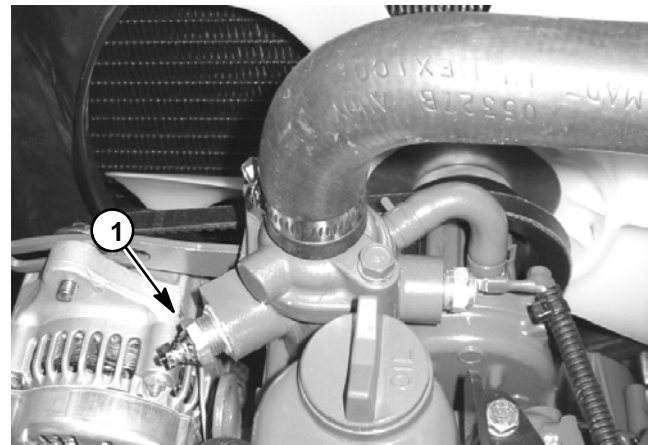

Figure 53

1. Temperature sender

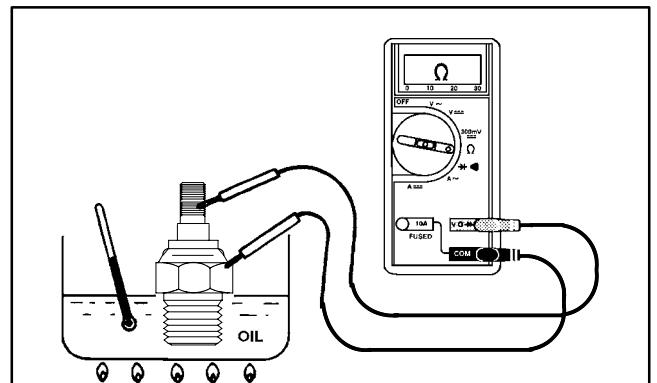

Figure 54

High Temperature Shutdown Switch

The high temperature shutdown switch is located on the water pump housing (Fig. 55). The high temperature shutdown switch is normally open and closes when engine coolant temperature reaches approximately 239°F (115°C). When excessive coolant temperature causes the shutdown switch to close, the engine shuts down. There is a tan wire attached to the shutdown switch.

NOTE: If excessive coolant temperature causes engine shutdown, the operator can restart the engine to allow the machine to be moved a short distance. After a restart in this condition, the engine will run for approximately 10 seconds before the engine shuts down again.

The Electronic Control Module (ECM) monitors the operation of the high temperature shutdown switch. The switch and its circuit wiring **should** be tested as an ECM input with the Diagnostic Display (see Special Tools and Troubleshooting in this chapter).

If excessive coolant temperature caused the ECM to shut down the engine, the Diagnostic light can be used to identify the fault (see Diagnostic Light in the Troubleshooting section of this chapter).

Testing

1. Park machine on a level surface, lower cutting units, stop engine, apply parking brake and remove key from ignition switch. Open hood to gain access to engine.



CAUTION

Make sure engine is cool before removing the temperature switch from engine.

2. Lower the coolant level in the engine and remove the high temperature shutdown switch from the engine.

3. Put the end of the switch in a container of oil with a thermometer and slowly heat the oil (Fig. 56).



CAUTION

Handle the hot oil with extreme care to prevent personal injury or fire.

4. Check resistance of the switch with a multimeter (ohms setting) as the oil temperature increases. The high temperature shutdown switch is normally open and should close from 234° to 244°F (112° to 118°C).

5. Replace shutdown switch if specifications are not met.

6. After testing is complete, install shutdown switch to the engine housing.

A. Clean threads of housing and switch thoroughly. Apply thread sealant to the threads of the switch.

B. Thread switch into the housing. Torque switch from **22 to 28 ft-lb (30 to 39 N-m)**.

C. Reconnect harness wire to switch.

7. Fill engine cooling system.

8. Lower and secure hood.

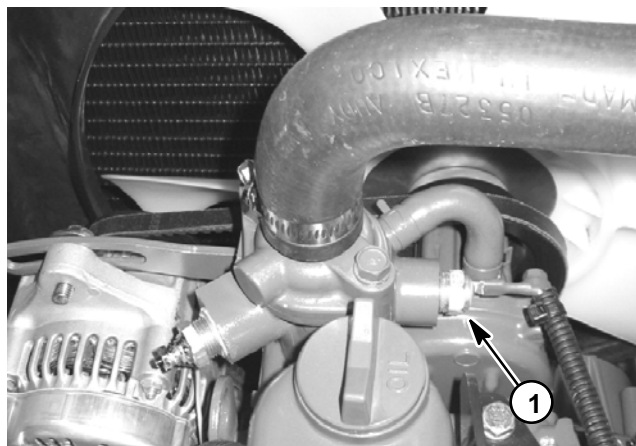

Figure 55

1. High temperature switch

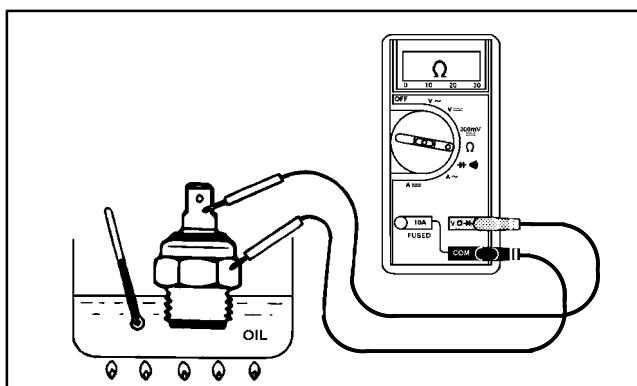

Figure 56

Oil Pressure Switch

The engine oil pressure switch is located on the engine near the oil filter (Fig.57). The oil pressure switch is a normally closed switch that opens with pressure.

The oil pressure switch should open at approximately 8 PSI (0.56 kg/cm²).

The Electronic Control Module (ECM) monitors the operation of the oil pressure switch. The switch and its circuit wiring **should** be tested as an ECM input with the Diagnostic Display (see Special Tools and Troubleshooting in this chapter).

If low engine oil pressure allowed the oil pressure switch to close during engine operation, the Diagnostic light can be used to identify the fault (see Diagnostic Light in the Troubleshooting section of this chapter).

Testing

NOTE: Refer to engine service manual for information regarding engine lubrication system and testing.

1. Turn the ignition switch to the RUN position. The oil pressure indicator light on the control panel should be illuminated.
2. If the indicator light is not illuminated, open hood to gain access to engine.
3. Locate oil pressure switch on engine and disconnect the harness wire from the switch.
4. With the ignition switch in the RUN position, ground the disconnected wire to the engine block.
5. If the light comes on, the oil pressure switch is faulty.
6. If the light does not come on after step 4, check the oil pressure light circuit wiring and indicator light (see Indicator Lights in this section).
7. After testing is completed, connect the harness wire to the switch. Lower and secure hood.

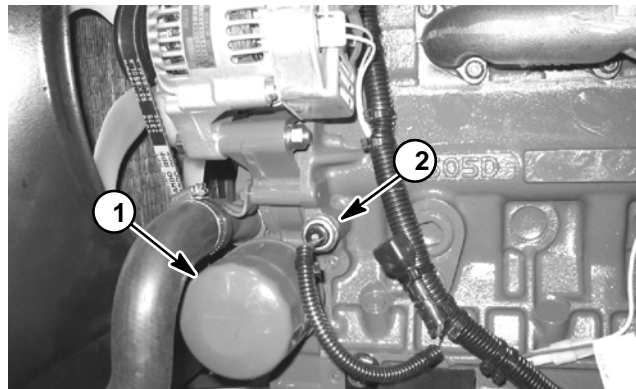

Figure 57

1. Oil filter

2. Oil pressure switch

Fuel Stop Solenoid

The fuel stop solenoid used on your Reelmaster must be energized for the diesel engine to run. The solenoid is mounted to the injection pump on the engine (Fig. 58).

The Electronic Control Module (ECM) monitors the operation of the fuel stop solenoid. The solenoid and its circuit wiring **should** be tested as an ECM output with the Diagnostic Display (see Special Tools and Troubleshooting in this chapter).

If the ECM detected a fuel stop solenoid problem during engine operation, the Diagnostic light can be used to identify the fault (see Diagnostic Light in the Troubleshooting section of this chapter).

Testing

1. Park machine on a level surface, lower cutting units, stop engine, apply parking brake and remove key from ignition switch. Open hood to gain access to engine.

2. Disconnect wire harness connector from fuel stop solenoid.

NOTE: The fuel stop solenoid may be removed from the engine or tested in place.

3. If the solenoid is removed from the engine, make sure that the solenoid plunger moves freely and is free of dirt, debris and corrosion.

NOTE: Prior to taking small resistance readings with a digital multimeter, short the test leads together. The meter will display a small resistance value (usually 0.5 ohms or less). This resistance is due to the internal resistance of the meter and test leads. Subtract this value from the measured value of the component you are testing.

4. Using a digital multimeter (ohms setting), touch one test lead to the pull coil terminal and the other test lead to the fuel stop solenoid frame (ground) (Fig. 59). The resistance of the pull coil should be less than 1 ohm (but not zero).

5. Using a digital multimeter (ohms setting), touch one test lead to the hold coil terminal and the other test lead to the fuel stop solenoid frame (ground) (Fig. 59). The resistance of the hold coil should be approximately 15 ohms.

6. If either coil resistance is incorrect, replace fuel stop solenoid.

7. Connect wire harness connector to the fuel stop solenoid.

8. Lower and secure hood.

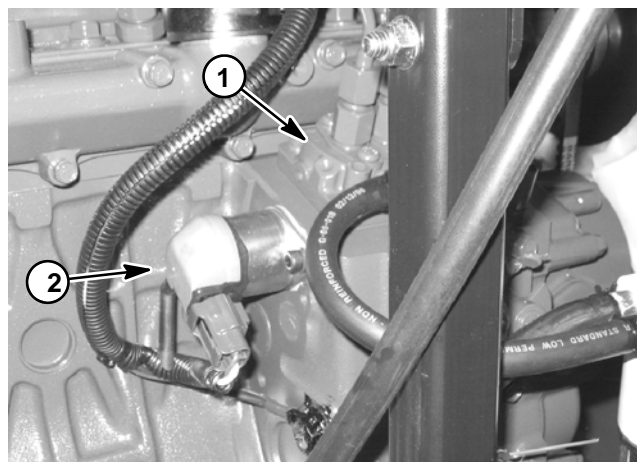

Figure 58

1. Injection pump 2. Fuel stop solenoid

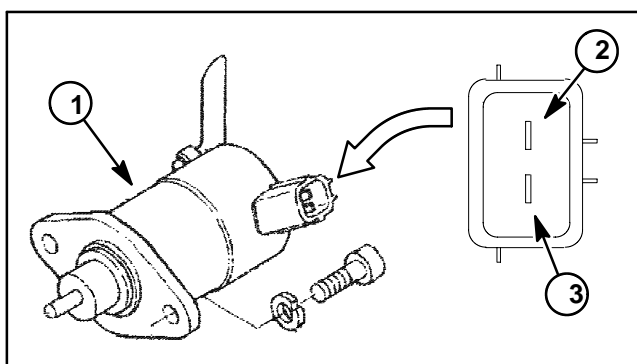



Figure 59

1. Fuel stop solenoid 3. Hold coil terminal
2. Pull coil terminal

Fuel Pump

The Reelmaster fuel pump is attached to the inside of the left side frame rail near the fuel tank (Fig. 65).

IMPORTANT: When testing fuel pump, make sure that pump is not operated without fuel.



DANGER

Because diesel fuel is highly flammable, use caution when handling it. Do not smoke while testing the fuel pump. Do not test fuel pump while engine is hot. Make sure that there is adequate ventilation when testing. Always wipe up any spilled fuel before starting the engine.

Fuel Pump Capacity Test

1. Park machine on a level surface, lower cutting units, stop engine and engage parking brake. Remove key from ignition switch. Raise operator seat and hood.
2. Disconnect harness electrical connector from the engine fuel stop solenoid to prevent the engine from starting (see Fuel Stop Solenoid in this section).
3. Disconnect fuel hose (pump discharge) from the fuel/water separator inlet fitting (Fig. 66).
4. Make sure fuel hoses attached to the fuel pump, fuel filter and fuel tank suction tube screen are free of obstructions.
5. Place disconnected hose into a large, graduated cylinder sufficient enough to collect 1 quart (0.95 liter).

IMPORTANT: When testing the fuel pump, DO NOT turn ignition switch to START.

Note: Machines that are equipped with a Biodiesel Conversion Kit will have the same fuel pump as machines with serial numbers above 280000000.

6. Collect fuel in the graduated cylinder by turning ignition switch to the RUN position. Allow pump to run for time listed below, then return switch to OFF.

A. For machines with serial numbers below 280000000, the amount of fuel collected in the graduated cylinder should be approximately **11.8 fl oz (350 ml) after thirty (30) seconds.**

B. For machines with serial numbers above 280000000, the amount of fuel collected in the graduated cylinder should be approximately **16 fl oz (475 ml) after fifteen (15) seconds.**

7. Replace fuel pump if necessary. Install fuel hose to the fuel/water separator. Make sure to secure fuel hose with hose clamp.

8. Connect harness electrical connector to the engine fuel stop solenoid.

9. Bleed the fuel system.

10. Lower and secure operator seat and hood.

Fuel Pump Specifications

Fuel pump specifications for machines with serial numbers below 280000000 are as follows:

Pump Capacity	23.5 fl oz/min (700 ml/min)
Pressure	3.3 PSI (22.8 kPa)
Current Draw	0.9 amp

Fuel pump specifications for machines with serial numbers above 280000000 are as follows:

Pump Capacity	64 fl oz/min (1.9 liters/min)
Pressure	7 PSI (48.3 kPa)
Current Draw	2.0 amp

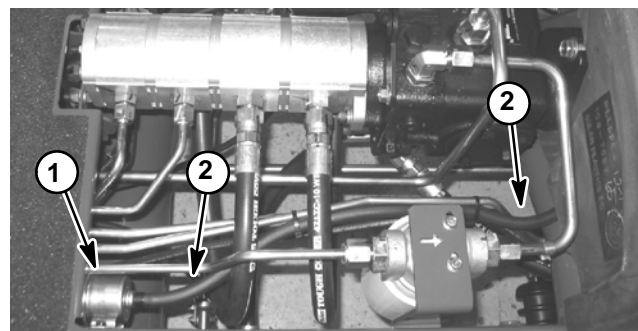

Figure 65

1. Fuel pump
2. Pump discharge hose

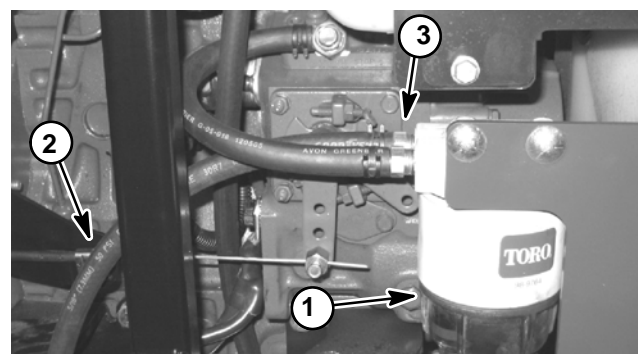

Figure 66

1. Fuel/water separator
2. Fuel hose (from pump)
3. Inlet fitting

Service and Repairs

NOTE: See the Kubota Workshop Manual: 05 Series Engine for engine electrical component repair information.

Battery Storage

If the machine will be stored for more than 30 days:

1. Remove the battery from the machine and charge it fully (see Battery Service).
2. Either store battery on a shelf or on the machine.
3. Leave cables disconnected if the battery is stored on the machine.

4. Store battery in a cool atmosphere to avoid quick deterioration of the battery charge.
5. To help prevent the battery from freezing, make sure it is fully charged (see Battery Service).

Battery Care

1. Battery electrolyte level must be properly maintained. The top of the battery must be kept clean. If the machine is stored in a location where temperatures are extremely high, the battery will discharge more rapidly than if the machine is stored in a location where temperatures are cool.

3. Battery cables must be tight on terminals to provide good electrical contact.

 CAUTION
<p>Wear safety goggles and rubber gloves when working with electrolyte. Charge battery in a well ventilated place so gasses produced while charging can dissipate. Since the gases are explosive, keep open flames and electrical sparks away from the battery; do not smoke. Nausea may result if the gases are inhaled. Unplug charger from electrical outlet before connecting or disconnecting charger leads to or from battery posts.</p>

 CAUTION
<p>Connecting battery cables to the wrong battery post could result in personal injury and/or damage to the electrical system.</p>

IMPORTANT: Do not remove battery fill caps while cleaning.

2. Check battery condition weekly or after every 50 hours of operation. Keep terminals and entire battery case clean because a dirty battery will discharge slowly.

A. Clean battery by washing entire case with a solution of baking soda and water. Rinse with clear water.

B. Coat battery posts and cable connectors with Battery Terminal Protector (Toro Part No. 107-0392) or petroleum jelly to prevent corrosion.

4. If corrosion occurs at terminals, disconnect cables. Always disconnect negative (-) cable first. Clean clamps and terminals separately. Reconnect cables with positive (+) cable first. Coat battery posts and cable connectors with Battery Terminal Protector (Toro Part No. 107-0392) or petroleum jelly to prevent corrosion.

5. Check electrolyte level every 25 operating hours, and every 30 days if machine is in storage.

6. Maintain cell level with distilled or demineralized water. Do not fill cells above the fill line.

Battery Service

The battery is the heart of the electrical system. With regular and proper service, battery life can be extended. Additionally, battery and electrical component failure can be prevented.

**CAUTION**

When working with batteries, use extreme caution to avoid splashing or spilling electrolyte. Electrolyte can destroy clothing and burn skin or eyes. Always wear safety goggles and a face shield when working with batteries.

Electrolyte Specific Gravity

Fully charged: 1.265 corrected to 80°F (26.7°C)
Discharged: less than 1.240

Battery Specifications

BCI Group Size 55
585 CCA at 0° F (-18° C)
Reserve Capacity of 95 minutes at 80°F (27°C)

Dimensions (including terminal posts)

Length 8.3 inches (21.1 cm)
Width 6.0 inches (15.2 cm)
Height 8.5 inches (21.6 cm)

Removal and Installation (Fig. 62)

1. Raise hood.
2. Loosen and remove negative cable from battery. After negative cable is removed, loosen and remove positive cable.
3. Loosen flange nut that secures battery retainer.
4. Carefully remove battery from machine.
5. Install battery in reverse order making sure to connect and tighten positive cable to battery before connecting negative cable.

NOTE: Before connecting the negative (ground) cable to the battery, connect a digital multimeter (set to DC Amps) between the negative battery post and the negative (ground) cable connector. The reading should be less than 0.1 amp. If the reading is 0.1 amp or more, the machine's electrical system should be tested for short circuits or faulty components and repaired.

6. Lower and secure hood.

Inspection, Maintenance and Testing

1. Perform the following inspections and maintenance:
 - A. Check battery case for cracks. Replace battery if cracked or leaking.

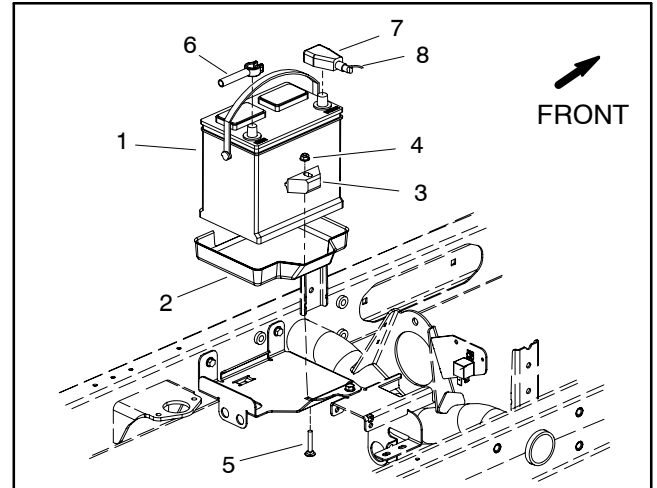

Figure 62

- | | |
|-----------------|---------------------------|
| 1. Battery | 5. Carriage screw |
| 2. Battery tray | 6. Negative battery cable |
| 3. Retainer | 7. Positive battery cable |
| 4. Flange nut | 8. Fusible link |

B. Check battery terminals for corrosion. If corrosion occurs at terminals, disconnect cables. Always disconnect negative (-) cable first. Clean cable clamps and battery terminals separately. Reconnect cables with positive (+) cable first. Coat battery posts and cable connectors with Battery Terminal Protector (Toro Part No. 107-0392) or petroleum jelly to prevent corrosion.

IMPORTANT: Before cleaning the battery, tape or block vent holes to the filler caps and make sure the caps are on tightly.

C. Check for signs of wetness or leakage on the top of the battery which might indicate a loose or missing filler cap, overcharging, loose terminal post or overfilling. Also, check battery case for dirt and oil. Clean the battery with a solution of baking soda and water, then rinse it with clean water.

D. Check that the cover seal is not broken away. Replace the battery if the seal is broken or leaking.

E. Check the electrolyte level in each cell. If the level is below the tops of the plates in any cell, fill all cells with **distilled water** between the minimum and maximum fill lines. Charge at 15 to 25 amps for 15 minutes to allow sufficient mixing of the electrolyte.

2. Conduct a hydrometer test of the battery electrolyte.

IMPORTANT: Make sure the area around the cells is clean before opening the battery caps.

A. Measure the specific gravity of each cell with a hydrometer. Draw electrolyte in and out of the hydrometer barrel prior to taking a reading to warm-up the hydrometer. At the same time take the temperature of the cell.

B. Temperature correct each cell reading. For each 10°F (5.5°C) above 80°F (26.7°C) add 0.004 to the specific gravity reading. For each 10°F (5.5°C) below 80°F (26.7°C) subtract 0.004 from the specific gravity reading.

Example: Cell Temperature	100°F
Cell Gravity	1.245
100°F minus 80°F equals 20°F	
(37.7°C minus 26.7°C equals 11.0°C)	
20°F multiply by 0.004/10°F equals 0.008	
(11°C multiply by 0.004/5.5°C equals 0.008)	
ADD (conversion above)	<u>0.008</u>
Correction to 80°F (26.7°C)	1.253

C. If the difference between the highest and lowest cell specific gravity is 0.050 or greater or the lowest cell specific gravity is less than 1.225, charge the battery. Charge at the recommended rate and time given in **Charging** or until specific gravity of all cells is 1.225 or greater with the difference in specific gravity between the highest and lowest cell less than 0.050. If these charging conditions can not be met, replace the battery.

3. Perform a high-discharge test with an adjustable load tester.

This is one of the most reliable means of testing a battery as it simulates the cold-cranking test. A commercial battery load tester is **required** to perform this test.

	CAUTION
Follow the battery load tester manufacturer's instructions when using a battery load tester.	

A. Check the voltage across the battery terminals prior to testing the battery. If the voltage is less than 12.4 VDC, recharge the battery.

B. If the battery has recently been charged, remove the battery surface charge before performing the load test. Disconnect the engine fuel stop solenoid to prevent the engine from starting. Engage the starter motor for 10 seconds to remove battery surface charge. Reconnect the fuel stop solenoid.

C. Make sure battery terminals are free of corrosion.

D. Measure the temperature of the center battery cell.

E. Connect a battery load tester to the battery terminals **following the load tester manufacturer's instructions**. Connect a digital multimeter to the battery terminals.

F. Apply a test load of 295 amps (one half the Cranking Performance rating of the battery) for 15 seconds.

G. Take a voltage reading after 15 seconds, then remove the load.

H. Using the table below, determine the minimum voltage for the cell temperature reading:

Minimum Voltage	Battery Electrolyte Temperature	
	9.6	70°F (and up)
9.5	60°F	15.6°C
9.4	50°F	10.0°C
9.3	40°F	4.4°C
9.1	30°F	-1.1°C
8.9	20°F	-6.7°C
8.7	10°F	-12.2°C
8.5	0°F	-17.8°C

I. If the test voltage is below the minimum, replace the battery. If the test voltage is at or above the minimum, return the battery to service.

Charging

To minimize possible damage to the battery and allow the battery to be fully charged, the slow charging method is presented here. This charging method can be accomplished with a constant current battery charger which is commonly available.

 CAUTION
<p>Follow the battery charger manufacturer's instructions when using a battery charger.</p>

NOTE: Using specific gravity of the battery cells is the most accurate method of determining battery condition.

1. Determine the battery charge level from either its specific gravity or open circuit voltage.

Battery Charge Level	Specific Gravity	Open Circuit Voltage
100%	1.265	12.68
75%	1.225	12.45
50%	1.190	12.24
25%	1.155	12.06
0%	1.120	11.89

2. Determine the charging time and rate **using the battery charger manufacturer's instructions** or the following table:

Battery Reserve Capacity (Minutes)	Battery Charge Level (Percent of Fully Charged)			
	75%	50%	25%	0%
80 or less	3.8 hrs @ 3 amps	7.5 hrs @ 3 amps	11.3 hrs @ 3 amps	15 hrs @ 3 amps
81 to 125	5.3 hrs @ 4 amps	10.5 hrs @ 4 amps	15.8 hrs @ 4 amps	21 hrs @ 4 amps
126 to 170	5.5 hrs @ 5 amps	11 hrs @ 5 amps	16.5 hrs @ 5 amps	22 hrs @ 5 amps
171 to 250	5.8 hrs @ 6 amps	11.5 hrs @ 6 amps	17.3 hrs @ 6 amps	23 hrs @ 6 amps
above 250	6 hrs @ 10 amps	12 hrs @ 10 amps	18 hrs @ 10 amps	24 hrs @ 10 amps



CAUTION

Do not charge a frozen battery because it can explode and cause injury. Let the battery warm to 60° F (15.5° C) before connecting to a charger.

Charge the battery in a well-ventilated place to dissipate gases produced from charging. These gases are explosive; keep open flame and electrical spark away from the battery. Do not smoke. Nausea may result if the gases are inhaled. Unplug the charger from the electrical outlet before connecting or disconnecting the charger leads from the battery posts.

3. **Following the battery charger manufacturer's instructions**, connect the charger cables to the battery. Make sure a good connection is made.
4. Charge the battery **following the battery charger manufacturer's instructions**.
5. Occasionally check the temperature of the battery electrolyte. If the temperature exceeds 125°F (51.6°C) or the electrolyte is violently gassing or spewing, the charging rate must be lowered or temporarily stopped.
6. Three hours prior to the end of the charging, measure the specific gravity of a battery cell once per hour. The battery is fully charged when the cells are gassing freely at a low charging rate and there is less than a 0.003 change in specific gravity for three consecutive readings.

Control Arm

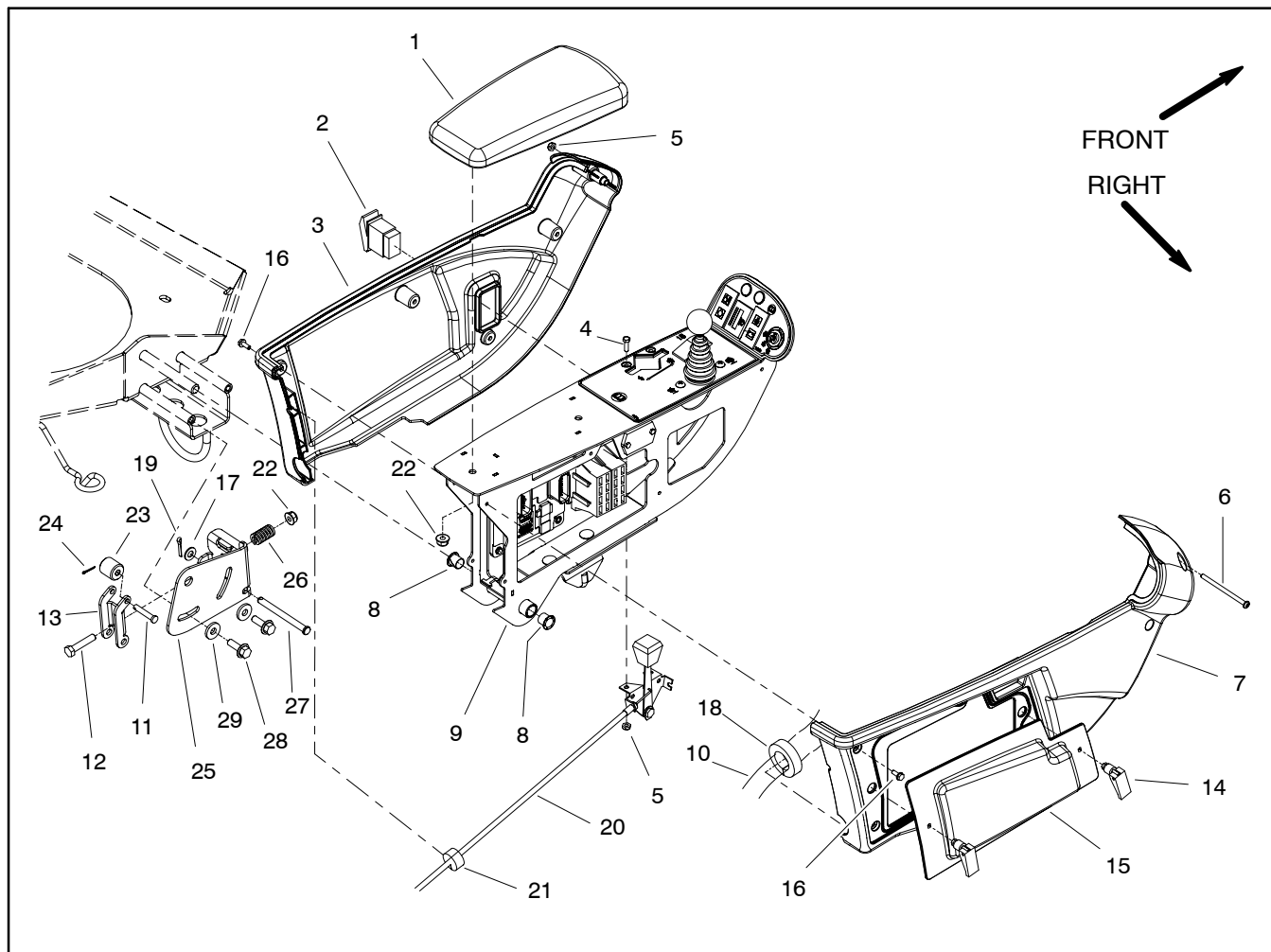

Figure 63

- | | | |
|-------------------------|---------------------------------|--------------------------------|
| 1. Arm rest | 11. Clevis pin | 21. Foam seal |
| 2. Headlight switch | 12. Screw | 22. Flange nut |
| 3. LH control arm cover | 13. Latch | 23. Spacer |
| 4. Screw (2 used) | 14. Swell latch (2 used) | 24. Cotter pin |
| 5. Lock nut | 15. Access cover | 25. Retainer bracket |
| 6. Screw | 16. Washer head screw (10 used) | 26. Spring |
| 7. RH control arm cover | 17. Flat washer | 27. Clevis pin |
| 8. Bushing | 18. Foam seal | 28. Flange head screw (2 used) |
| 9. Control arm | 19. Cotter pin | 29. Flat washer (2 used) |
| 10. Seat wire harness | 20. Throttle control assembly | |

Disassembly (Fig. 63)

1. Park machine on a level surface, lower cutting units, stop engine and engage parking brake. Remove key from ignition switch.
2. Loosen latches and remove access cover from outside of control arm.
3. At front of control arm, remove screw (item 6) and lock nut (item 5) that secure control arm covers to each other.
4. Remove five (5) washer head screws (item 16) that secure each cover to control arm.
5. Remove control arm covers from machine. As LH control arm cover (item 3) is removed from control arm, unplug wire harness connector from headlight switch.
6. Remove electrical components from control arm as needed using Figure 65 as a guide.

Assembly (Fig. 63)

1. Install all removed electrical components to control arm using Figure 65 as a guide.
2. Position covers to control arm. As LH cover (item 3) is placed, plug wire harness connector to headlight switch. Also, make sure that wire harness and throttle control cable are routed correctly through cover openings (Fig. 64).
3. Secure each cover to control arm with five (5) washer head screws (item 16). Install screw (item 6) and lock nut (item 5) to secure covers at front of control arm.
4. Install access cover to outside of control arm.

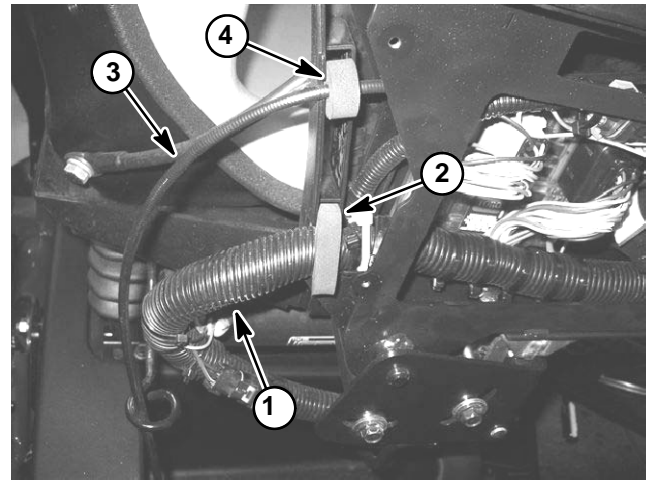

Figure 64

- | | |
|----------------------|---------------------------|
| 1. Wire harness | 3. Throttle control cable |
| 2. Harness foam seal | 4. Cable foam seal |

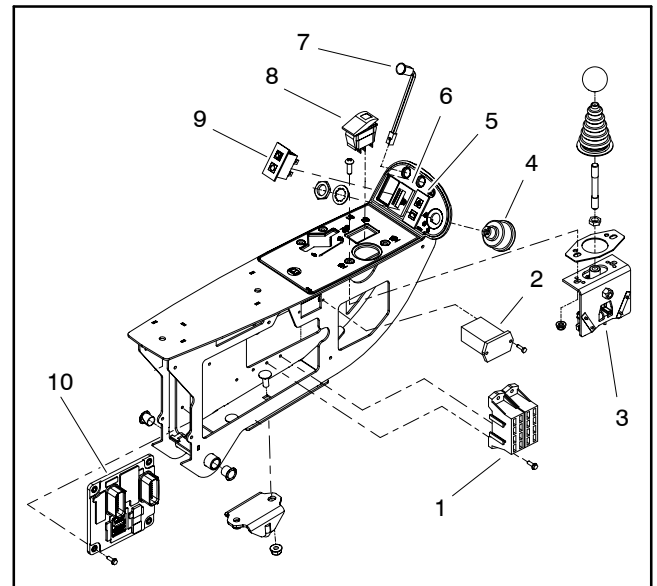

Figure 65

- | | |
|----------------------|----------------------|
| 1. Fuse block | 6. Temperature gauge |
| 2. Hour meter | 7. Diagnostic light |
| 3. Joystick assembly | 8. PTO switch |
| 4. Ignition switch | 9. Indicator light |
| 5. Indicator light | 10. ECM |

Hydraulic Solenoid Valve Coil

A hydraulic solenoid valve coil on the mow control manifold (Fig. 66) or lift control manifold (Fig. 67) can be replaced without opening the hydraulic system.

Removal

1. Park machine on a level surface, lower cutting units, stop engine and engage parking brake. Remove key from ignition switch.

2. Locate the solenoid valve coil that is to be replaced.

A. Tilt operator seat up to gain access to hydraulic mow control manifold. Refer to Figure 66 for solenoid coil locations on the mow control manifold.

B. The lift control manifold is attached to a frame bracket under the operator floor plate. Access to the lift control manifold can be obtained by removing the floor plate. Refer to Figure 67 for solenoid coil locations on the lift control manifold.

3. Disconnect the wire harness electrical connector from the solenoid valve coil to be replaced.

4. Remove the nut from the hydraulic valve.

5. If equipped (SV1 and SV3 on lift control manifold), remove coil spacer from hydraulic valve.

6. Slide the solenoid coil from the valve.

7. Clean any corrosion or dirt from the valve.

Installation

1. Slide new coil assembly onto the hydraulic valve.

2. If equipped (SV1 and SV3 on lift control manifold), slide coil spacer onto hydraulic valve.

3. Install the nut onto the valve and torque nut from **48 to 60 in-lb (5.4 to 6.7 N-m)** (do not over tighten).

4. Connect the machine wire harness connector to the solenoid coil.

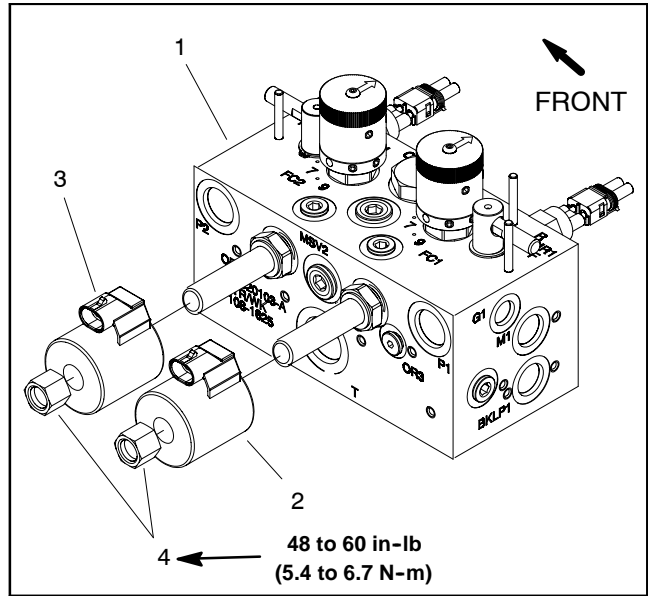

Figure 66

- | | |
|-------------------------|-----------------------|
| 1. Mow control manifold | 3. Solenoid coil MSV2 |
| 2. Solenoid coil MSV1 | 4. Nut |

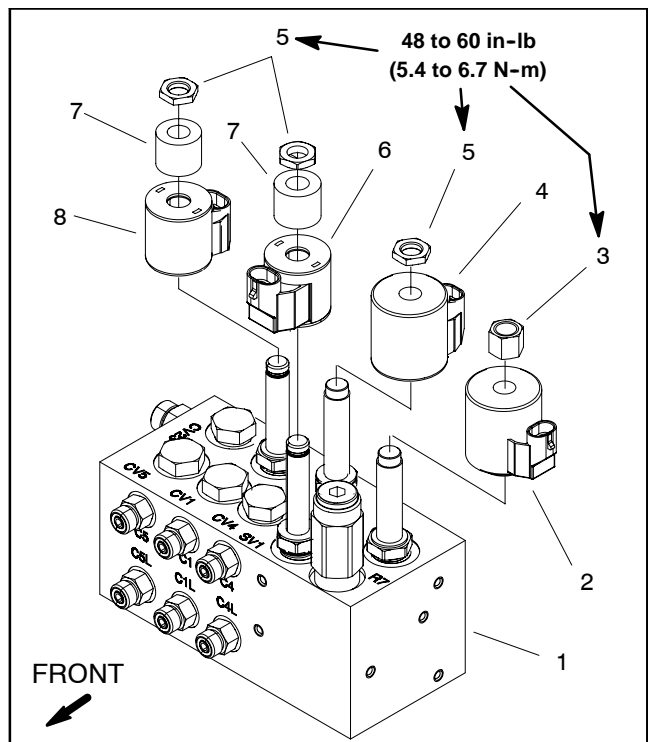

Figure 67

- | | |
|--------------------------|----------------------|
| 1. Lift control manifold | 5. Nut |
| 2. Solenoid coil SVRV | 6. Solenoid coil SV1 |
| 3. Nut | 7. Coil spacer |
| 4. Solenoid coil SV2 | 8. Solenoid coil SV3 |

Backlap Switches

Removal (Figs. 68 and 69)

1. Park machine on a level surface, lower cutting units, stop engine and engage parking brake. Remove key from ignition switch.
2. Tilt operator seat up to gain access to hydraulic mow control manifold.
3. Locate the backlap switch on the mow control manifold that is to be replaced (Fig. 68).
4. Disconnect the wire harness electrical connector from the backlap switch that is to be removed.
5. Loosen and remove backlap switch from hydraulic manifold. Remove and discard o-ring.

Installation (Figs. 68 and 69)

1. Make sure that dowel pin and ball are placed in manifold port as shown in Figure 69.
2. Install backlap switch with new o-ring into manifold port and torque to **15 ft-lb (20 N-m)**.
3. Connect harness electrical connector to the backlap switch. Use the Diagnostic Display to verify that backlap switches **are** functioning correctly.
4. Lower operator seat.

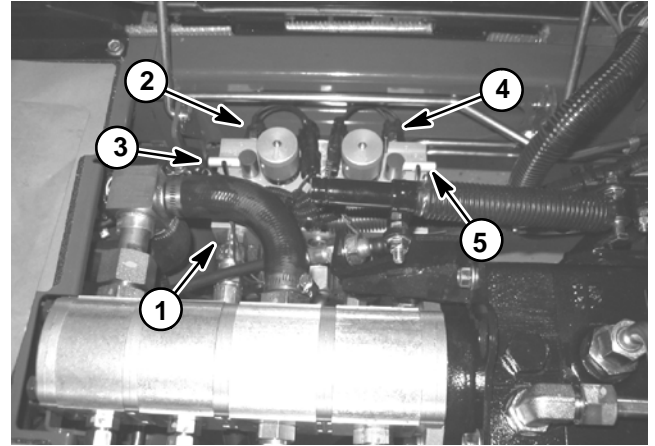

Figure 68

- | | |
|-------------------------|------------------------|
| 1. Mow manifold | 4. Rear backlap switch |
| 2. Front backlap switch | 5. Rear backlap lever |
| 3. Front backlap lever | |

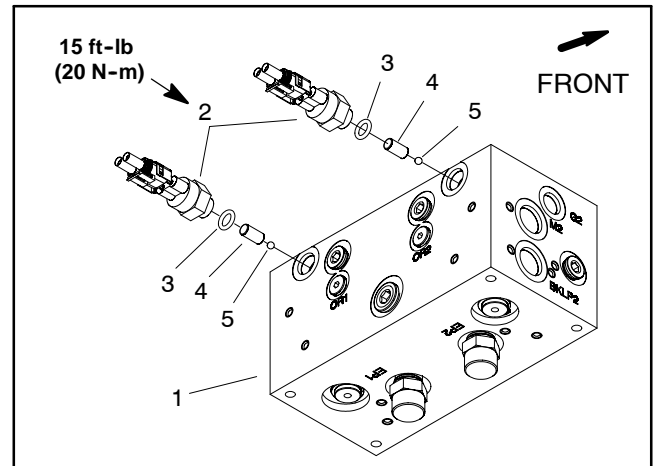

Figure 69

- | | |
|-------------------|--------------|
| 1. Mow manifold | 4. Dowel pin |
| 2. Backlap switch | 5. Ball |
| 3. O-ring | |

TurfDefender™ Leak Detector (Optional)

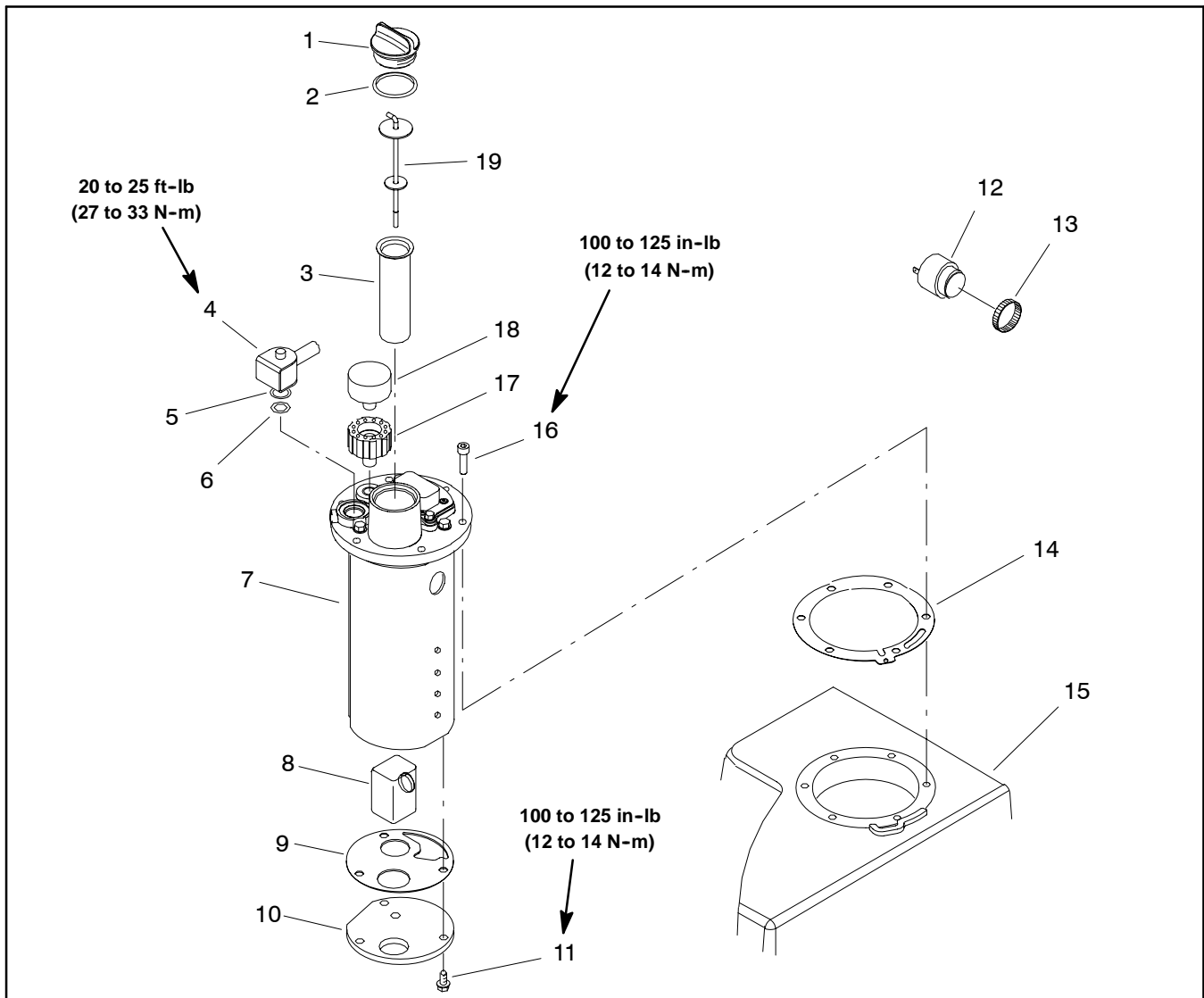

Figure 70

- | | | |
|---------------------------|------------------------|--------------------------------|
| 1. Cap | 8. Float | 14. Gasket |
| 2. O-ring | 9. Gasket | 15. Hydraulic reservoir |
| 3. Filter screen | 10. Bottom cover | 16. Socket head screw (6 used) |
| 4. Solenoid valve | 11. Cap screw (3 used) | 17. Breather adapter |
| 5. O-ring | 12. Alarm | 18. Breather |
| 6. O-ring | 13. Plastic nut | 19. Dipstick |
| 7. Leak detector assembly | | |

TurfDefender™ Operation

The optional TurfDefender™ is an electronic hydraulic fluid leak detection device that fits inside the hydraulic reservoir of the machine. It is a pressure based system which requires a sealed hydraulic reservoir to function properly.

The solenoid valve that is attached to the leak detector assembly allows the microprocessor of the TurfDefender™ to keep the hydraulic reservoir pressurized during machine operation. When the solenoid valve is energized during normal operation, the solenoid valve plunger seals to prevent venting of the hydraulic reservoir.

Very small changes to the oil level in the sealed hydraulic reservoir result in movement of the leak detector's internal float. The internal microprocessor of the TurfDefender™ analyzes the float movement and determines if there is a leak in the hydraulic system or if the change is caused by other factors (e.g. hydraulic fluid temperature changes or lift cylinder operation). During machine operation, if a hydraulic leak is detected, the TurfDefender™ alarm will sound long, continuous beeps and the cutting units will be shut off.

When the ignition switch is turned to RUN, the TurfDefender™ alarm should sound a single, short beep indicating normal operation. If there is no beep when the ignition switch is turned to RUN or if the alarm gives 4 short beeps it means a system problem has been detected that should be checked by a technician.

The handheld Diagnostic Display (see Special Tools in this chapter) with the TurfDefender™ overlay decal (supplied with TurfDefender™ kit) can be used to accurately check hydraulic reservoir oil level and also to identify causes of TurfDefender™ problems. See Troubleshooting in this chapter for information on troubleshooting the TurfDefender™ system.

TurfDefender™ Service

1. The solenoid valve can be removed from the upper housing for inspection if necessary. Two (2) o-rings are used to seal the solenoid valve to the upper housing. The solenoid coil resistance should be approximately 69 ohms. When installing solenoid valve into upper housing, torque from **20 to 25 ft-lb (27 to 33 N-m)**.

2. If the leak detector assembly is to be removed from the hydraulic reservoir:

A. Tip the hydraulic reservoir cover to gain access to TurfDefender™. Thoroughly clean the top of the hydraulic reservoir around the TurfDefender™ upper housing.

B. Disconnect leak detector wire harness connector from machine wire harness. Disconnect wire harness connectors from the alarm.

C. Remove six (6) socket head screws that secure leak detector assembly to hydraulic reservoir. Lift leak detector from reservoir. Remove and discard gasket from between leak detector assembly and hydraulic reservoir.

3. The main body of the TurfDefender™ is not serviceable and disassembly should not be necessary. Removal of the upper housing from the leak detector housing is not recommended.

4. Access to the internal float can be completed by removing the bottom cover (item 10) and gasket (item 9). If bottom cover is removed, carefully clean mating surfaces and replace gasket. Secure bottom cover with three (3) cap screws and torque from **100 to 125 in-lb (12 to 14 N-m)**.

5. To install leak detector assembly to the hydraulic reservoir:

A. Position new gasket to the top of the hydraulic reservoir. Make sure that the gasket holes align correctly with holes in hydraulic reservoir.

B. Insert leak detector into reservoir opening. Align holes in leak detector housing, gasket and hydraulic reservoir.

C. Secure leak detector assembly to hydraulic reservoir with six (6) socket head screws. Torque screws from **100 to 125 in-lb (12 to 14 N-m)**.

D. Connect leak detector wire harness connector to machine wire harness. Correctly connect wire harness leads to alarm (red/yellow harness wire to alarm + terminal and black/yellow wire to alarm - terminal).

E. Lower hydraulic reservoir cover and secure in place.

This page is intentionally blank.



Table of Contents

SPECIFICATIONS 2
GENERAL INFORMATION 2
 Traction Unit Operator's Manual 2
SERVICE AND REPAIRS 4
 Wheels 4
 Steering Column 6
 Brake Service 8
 Rear Wheel Bearings (2 Wheel Drive) 12
 Rear Axle 14
 Rear Axle Service 16
 Operator Seat 18
 Mechanical Seat Suspension 20
 Front Lift Arms 22
 Rear Lift Arms 24

Specifications

Item	Description
Front Tire Pressure (except RM- 5210) (26.5 x 14.0 - 12, 4 ply, tubeless)	12 to 15 PSI (83 to 103 kPa)
Front Tire Pressure (RM- 5210) (24 x 13.0 - 12, 4 ply, tubeless)	12 to 15 PSI (83 to 103 kPa)
Rear Tire Pressure (except RM- 5210) (20 x 12.0 - 10, 4 ply, tubeless)	12 to 15 PSI (83 to 103 kPa)
Rear Tire Pressure (RM- 5210) (20 x 10.0 - 10, 4 ply, tubeless)	12 to 15 PSI (83 to 103 kPa)
Wheel Lug Nut Torque	70 to 90 ft- lb (95 to 122 N- m)

General Information

Traction Unit Operator's Manual

The Traction Unit Operator's Manual provides information regarding the operation, general maintenance and maintenance intervals for your Reelmaster machine. Refer to that publication for additional information when servicing the machine.

This page is intentionally blank.

Service and Repairs

Wheels

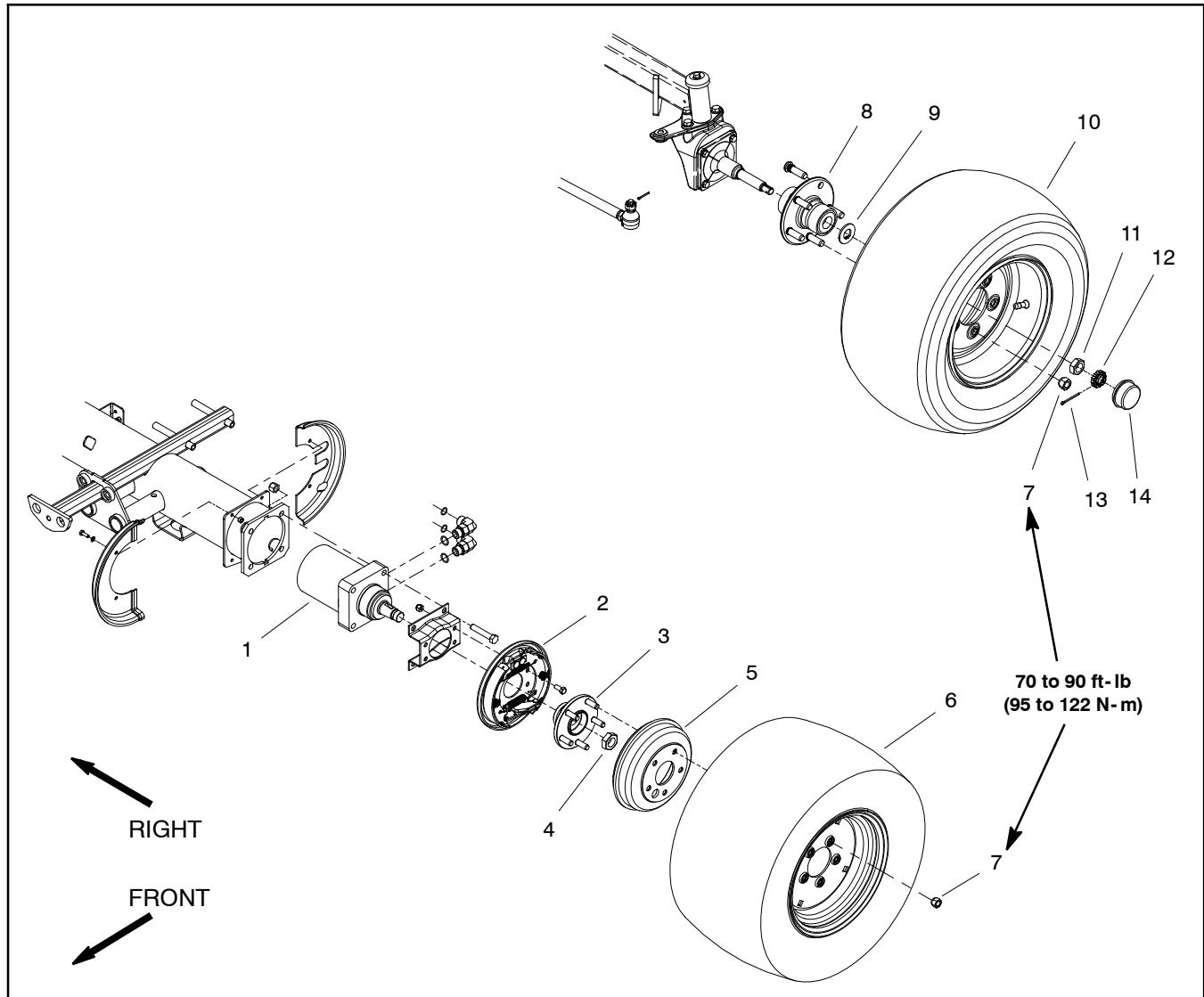

Figure 1

- 1. Front wheel motor
- 2. Brake assembly
- 3. Front wheel hub
- 4. Lock nut
- 5. Brake drum

- 6. Front wheel
- 7. Lug nut (5 used per wheel)
- 8. Rear wheel hub
- 9. Tab washer
- 10. Rear wheel

- 11. Jam nut
- 12. Retainer
- 13. Cotter pin
- 14. Dust cap

Removal (Fig. 1)

1. Park machine on a level surface, lower cutting units, stop engine, engage parking brake and remove key from the ignition switch.
2. Chock wheels to prevent machine from shifting.
3. Loosen lug nuts.

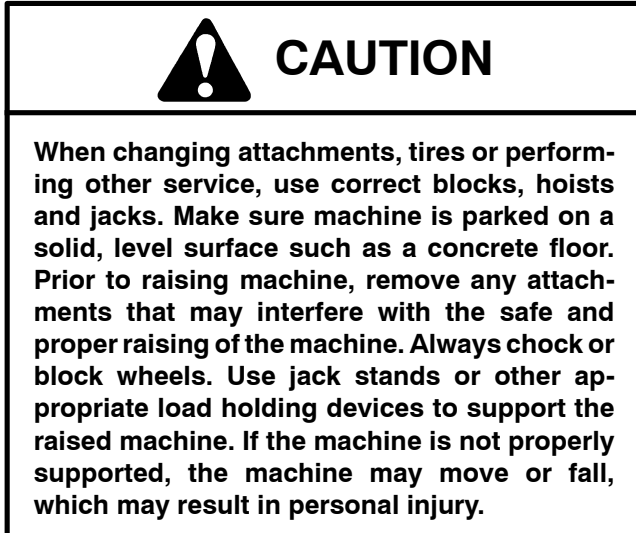

4. Using a jack, raise machine so wheel is off ground (see Jacking Instructions in Chapter 1 - Safety). Support machine with jack stands.
5. Remove lug nuts and then remove wheel from machine.

Installation (Fig. 1)

1. Install wheel and secure with five (5) lug nuts.
2. Lower machine to ground.
3. Torque lug nuts evenly in a crossing pattern from **70 to 90 ft-lb (95 to 122 N-m)**.

Steering Column

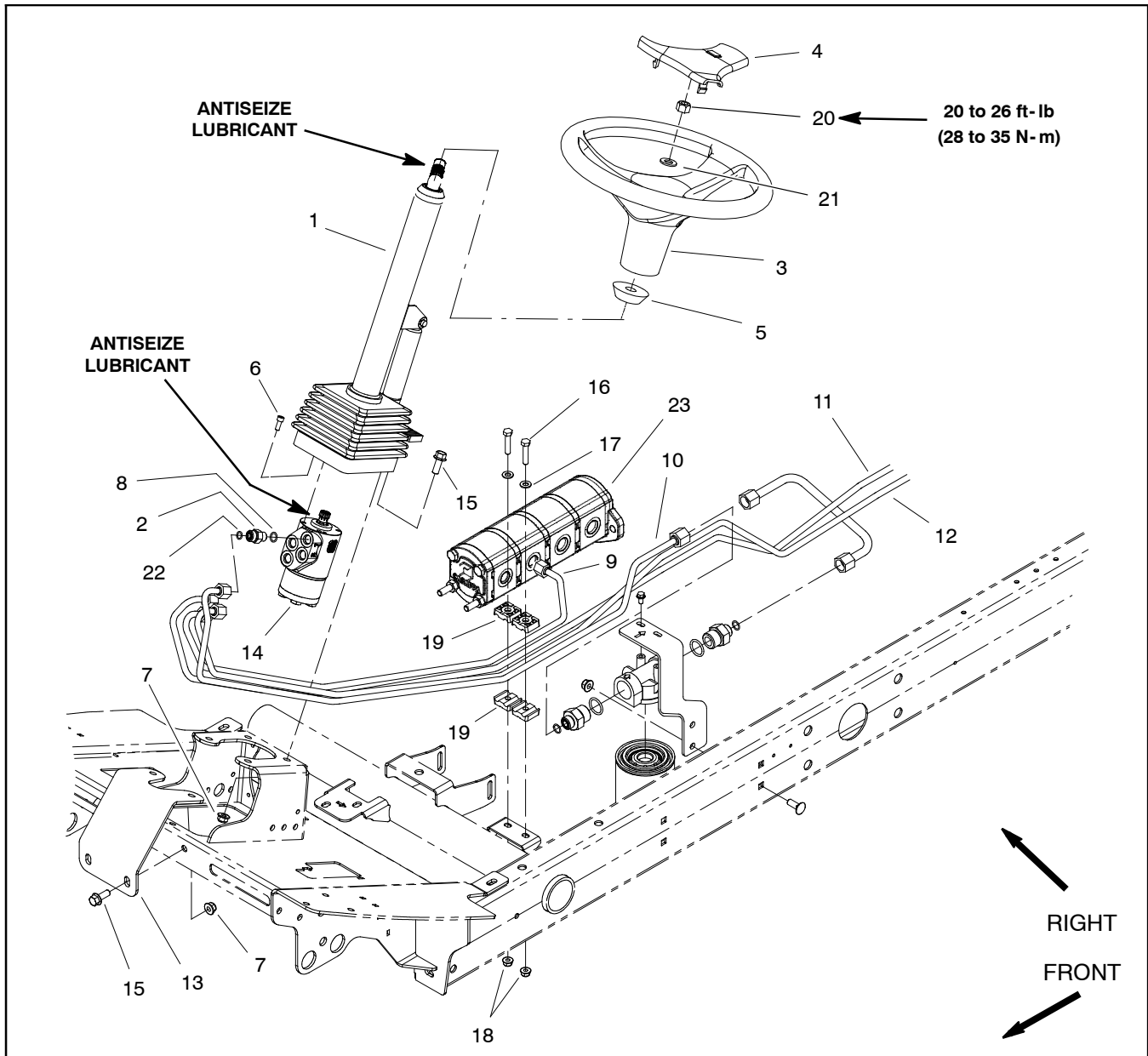

Figure 2

- | | | |
|-------------------------------|--------------------------------|--------------------------|
| 1. Steering column | 9. Hydraulic tube | 17. Flat washer (2 used) |
| 2. Hydraulic fitting (4 used) | 10. Hydraulic tube | 18. Flange nut |
| 3. Steering wheel | 11. Hydraulic tube | 19. Tube clamp |
| 4. Steering wheel cover | 12. Hydraulic tube | 20. Lock nut |
| 5. Foam column | 13. Column brace | 21. Flat washer |
| 6. Socket head screw (4 used) | 14. Steering control valve | 22. O-ring |
| 7. Flange nut | 15. Flange head screw (6 used) | 23. Gear pump |
| 8. O-ring | 16. Cap screw (2 used) | |

Removal (Fig. 2)

1. Park the machine on a level surface, engage the parking brake, lower the cutting units and stop the engine. Remove the key from the ignition switch.

2. Remove cover from steering wheel by carefully prying up on one of the cover spokes.

3. Remove lock nut and flat washer that secure steering wheel to steering column.

4. Use a suitable puller to remove steering wheel from steering column. Remove foam collar.

5. Remove platform shroud from machine to allow access to steering column fasteners (Fig. 3).

- A. Remove cover plate from platform.
- B. Remove fasteners that secure shroud to machine.
- C. Remove shroud from machine.
- D. Locate and retrieve two (2) rubber bushings and spacers.

6. Slide rubber bellows up steering column to allow access to fasteners that secure steering column to machine.

7. Support steering control valve to prevent it from falling during steering column removal.

8. Loosen and remove four (4) socket head screws (item 6) that secure steering control valve to steering column.

9. Loosen and remove four (4) flange head screws (item 15) and flange nuts (item 7) that secure steering column to machine.

10. Slide steering column assembly from steering control valve and machine.

11. Disassemble steering column assembly as needed using Figure 4 as a guide.

Installation (Fig. 2)

1. Apply antiseize lubricant to input shaft of steering control valve.

2. Slide steering column onto steering control valve. Secure steering column in place with four (4) flange head screws (item 15) and flange nuts (item 7).

3. Secure steering control valve to steering column with four (4) socket head screws (item 6).

4. Slide rubber bellows to bottom of steering column.

5. Place rubber bushings and spacers into holes of shroud. Position shroud in place and secure with removed fasteners.

6. Slide foam collar onto steering column.

7. Thoroughly clean tapered surfaces of steering wheel and steering column.

8. Apply antiseize lubricant to splines of steering column taking care to keep antiseize lubricant from column taper. Slide steering wheel onto steering column.

9. Secure steering wheel to steering column with flat washer and lock nut. Torque hex nut from **20 to 26 ft-lb (28 to 35 N-m)**.

10. Install steering wheel cover to steering wheel.

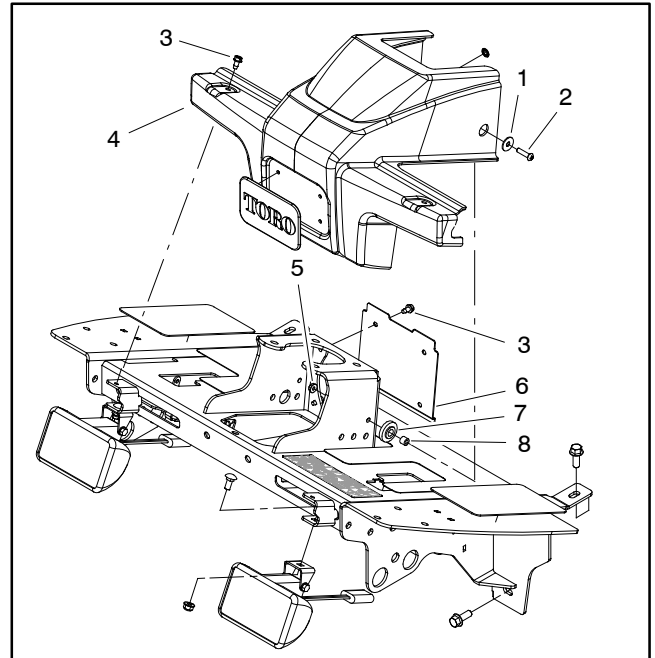

Figure 3

- | | |
|----------------------|---------------------|
| 1. Washer (2 used) | 5. Lock nut |
| 2. Screw (2 used) | 6. Cover plate |
| 3. Washer head screw | 7. Bushing (2 used) |
| 4. Platform shroud | 8. Spacer (2 used) |

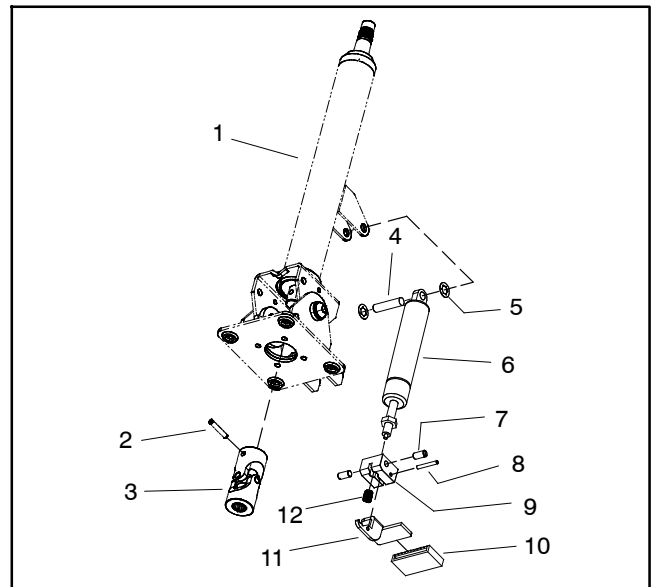

Figure 4

- | | |
|-------------------------|------------------|
| 1. Steering column | 7. Bolt (2 used) |
| 2. Pin | 8. Pin |
| 3. Universal joint | 9. Pedal block |
| 4. Pin | 10. Pedal cover |
| 5. Lock washer (2 used) | 11. Pedal |
| 6. Cylinder | 12. Spring |

Brake Service

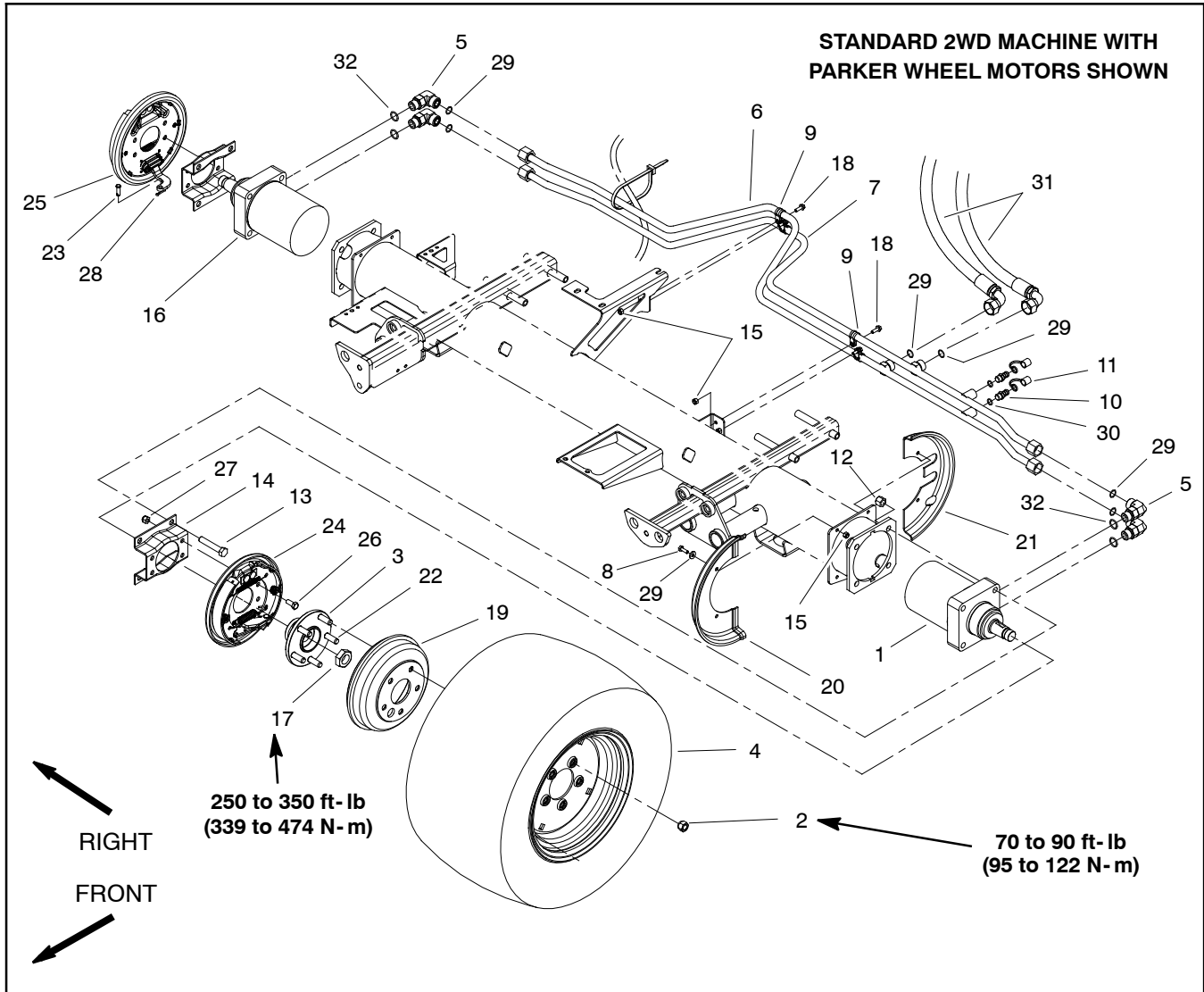

Figure 5

- | | | |
|---|--|---------------------------------------|
| 1. LH wheel motor (Parker) | 12. Lock nut (4 used per wheel motor) | 23. Clevis pin (2 used) |
| 2. Lug nut (5 used per wheel) | 13. Cap screw (4 used per wheel motor) | 24. LH brake assembly |
| 3. Hub | 14. Brake bracket (2 used) | 25. RH brake assembly |
| 4. Tire and wheel assembly | 15. Lock nut | 26. Cap screw (4 used per brake assy) |
| 5. Hydraulic fitting (2 used per motor) | 16. RH wheel motor (Parker) | 27. Lock nut (4 used per brake assy) |
| 6. Hydraulic tube | 17. Lock nut (2 used) | 28. Cotter pin (2 used) |
| 7. Hydraulic tube | 18. Flange head screw (4 used) | 29. O-ring |
| 8. Cap screw (2 used per wheel shield) | 19. Brake drum (2 used) | 30. O-ring |
| 9. R-clamp (4 used) | 20. Front wheel shield (LH shown) | 31. Hydraulic hose |
| 10. Diagnostic fitting (2 used) | 21. Rear wheel shield (LH shown) | 32. O-ring |
| 11. Dust cap (2 used) | 22. Wheel stud (5 used per wheel) | |

Removal (Fig. 5)

1. Park the machine on a level surface, lower the cutting units and stop the engine. Remove the key from the ignition switch.
2. Chock wheels to prevent machine from shifting.
3. Loosen, but do not remove, lock nut (item 17) from wheel motor shaft.
4. Remove front wheel assembly (see Wheel Removal in this section). Make sure to support machine with jack stands.
5. Make sure parking brake is disengaged.

NOTE: Clevis pin that secures brake cable to brake actuator lever is secured with cotter pin (shown in Fig. 5) or extension spring (shown in Figs. 6 and 7).

6. Remove cotter pin or spring from clevis pin that secures brake cable to brake actuator lever. Remove clevis pin and position brake cable away from brake actuator lever.
7. Remove brake drum.

IMPORTANT: DO NOT hit wheel hub, puller or wheel motor with a hammer during wheel hub removal or installation. Hammering may cause damage to the wheel motor.

8. Make sure that lock nut on wheel motor shaft is loose. Use appropriate puller to loosen wheel hub from wheel motor shaft.
9. Remove lock nut and wheel hub from motor shaft. Locate and retrieve woodruff key.

NOTE: If desired, the complete brake assembly can be removed from the machine for disassembly (see step 12).

10. Remove upper and lower shoe springs from brake shoes.
11. Remove shoe hold down cups and hold down springs. Remove brake shoes and hold down pins from backing plate.
12. If necessary, remove backing plate from machine by loosening and removing four (4) cap screws and lock nuts.

Installation (Fig. 5)

1. Remove rust and debris from all parts with a wire brush prior to installation. Clean all parts. Inspect brake shoe contact surfaces of the brake drum for excessive wear. Replace any worn or damaged parts.

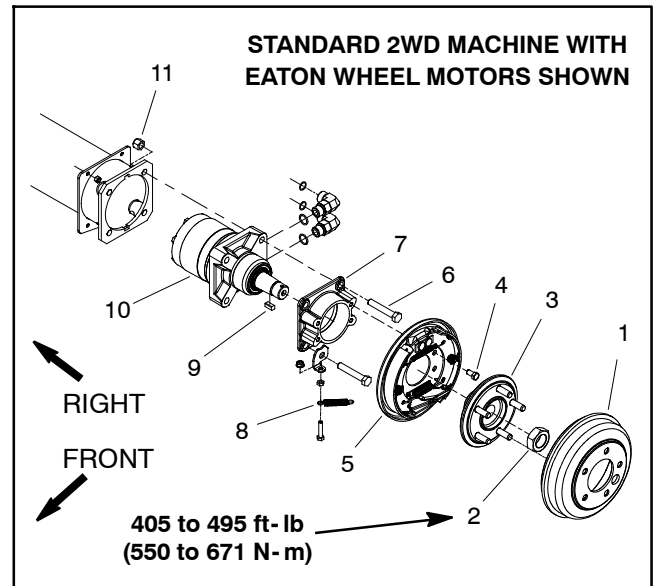

Figure 6

- | | |
|-----------------------|-------------------------|
| 1. Brake drum | 7. Brake adapter |
| 2. Lock nut | 8. Extension spring |
| 3. Wheel hub | 9. Square key |
| 4. Cap screw (4 used) | 10. Wheel motor (Eaton) |
| 5. Brake assembly | 11. Lock nut (4 used) |
| 6. Cap screw (4 used) | |

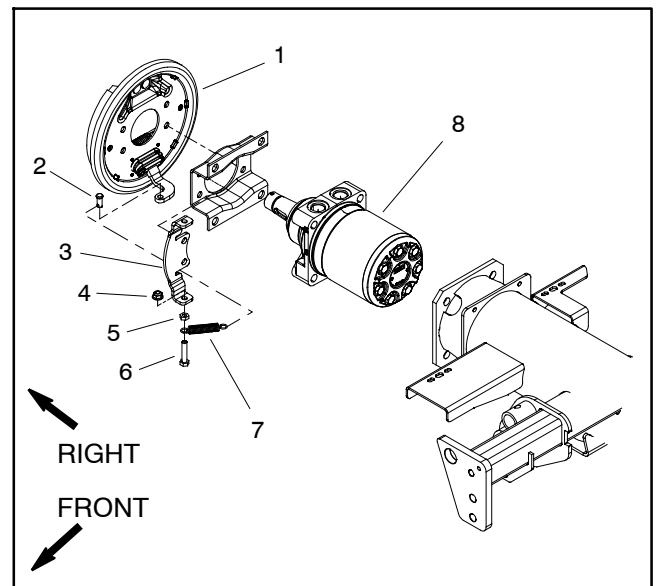

Figure 7

- | | |
|-------------------------|-------------------------|
| 1. Brake assembly | 5. Jam nut |
| 2. Clevis pin | 6. Cap screw |
| 3. Brake spring bracket | 7. Extension spring |
| 4. Flange nut | 8. Wheel motor (Parker) |

2. If backing plate was removed from machine, secure backing plate to brake bracket with four (4) cap screws and lock nuts.

3. Lightly lubricate brake shoe pivot points with general purpose grease.

4. Position one brake shoe to the backing plate. Install brake hold down pin and secure with hold down spring and cup. Repeat for second brake shoe.

5. Install upper and lower shoe springs to brake shoes. Make sure that brake shoes are properly positioned to pivot and actuator points.

IMPORTANT: Before wheel hub is installed, thoroughly clean tapers of wheel hub and wheel motor shaft. Make sure that tapers are free of grease, oil and dirt. Do not use antiseize lubricant when installing wheel hub.

6. Mount key in the wheel motor shaft, then install the wheel hub onto the wheel motor shaft.

7. Secure wheel hub onto the wheel motor shaft with lock nut (item 17).

8. Install brake drum.

9. Position brake cable end to brake actuator lever. Secure brake cable clevis to brake actuator lever with clevis pin and cotter pin or spring.

10. Install front wheel assembly (see Wheel Installation in this section).

11. Check and adjust brakes.

12. Lower machine to ground.

13. Torque lug nuts evenly in a crossing pattern from **70 to 90 ft-lb (95 to 122 N-m)**. Torque lock nut (item 17) that secures wheel hub as follows:

A. On machines with Parker wheel motors, torque lock nut from **250 to 350 ft-lb (339 to 474 N-m)**.

B. On machines with Eaton wheel motors, torque lock nut from **405 to 495 ft-lb (550 to 671 N-m)**.

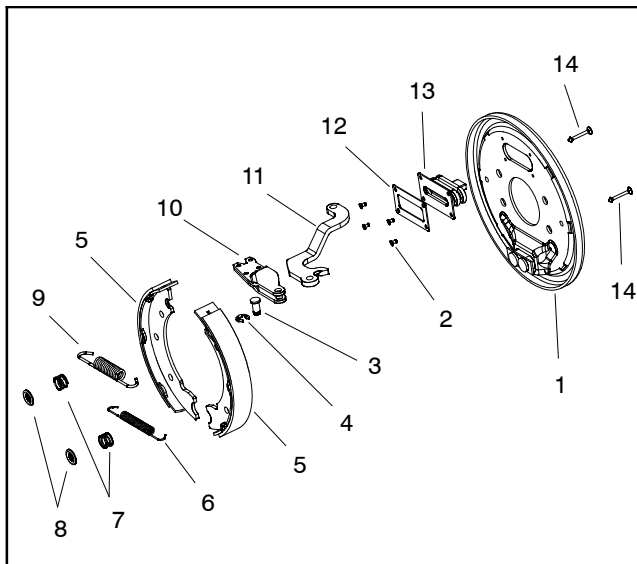

Figure 8

- | | |
|----------------------|----------------------|
| 1. Backing plate | 8. Hold down cup |
| 2. Rivet (4 used) | 9. Upper shoe spring |
| 3. Clevis pin | 10. Brake actuator |
| 4. Retaining ring | 11. Actuator lever |
| 5. Brake shoe | 12. Back-up plate |
| 6. Lower shoe spring | 13. Boot |
| 7. Hold down spring | 14. Hold down pin |

Burnish Brake Pads

After brake pad replacement, burnish (break-in) the brakes before use.

1. Bring the machine to full speed and apply the brakes to rapidly stop the machine without skidding or locking up the wheels.

2. Repeat this procedure for 10 times. To avoid overheating the brakes, wait 1 minute between each stop.



CAUTION

After servicing the brakes, always check the brakes in a wide open, level area that is free of other persons and obstructions.

This page is intentionally blank.

Rear Wheel Bearings (2 Wheel Drive)

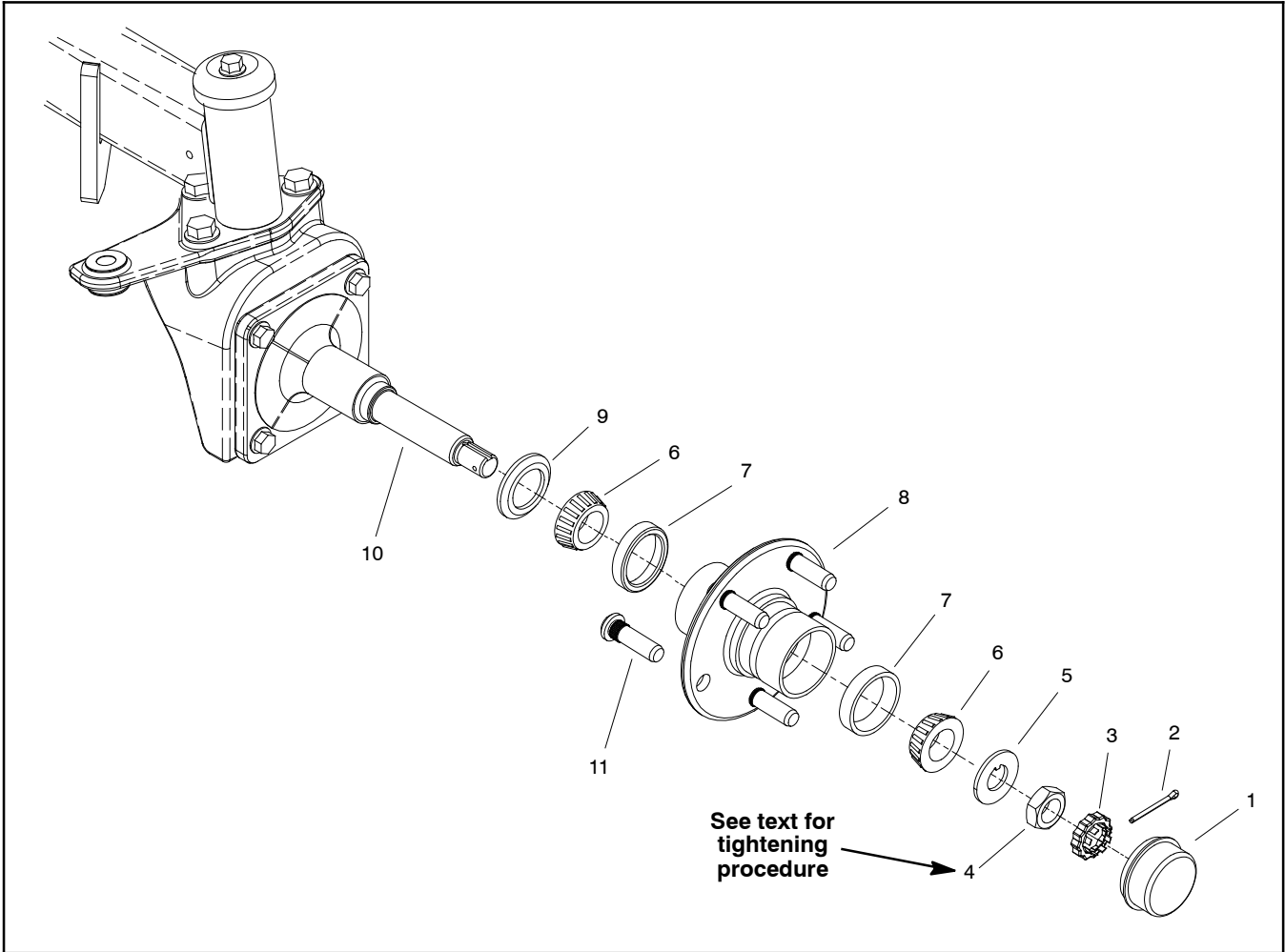

Figure 9

- 1. Dust cap
- 2. Cotter pin
- 3. Retainer
- 4. Jam nut

- 5. Tab washer
- 6. Bearing cone
- 7. Bearing cup
- 8. Wheel hub

- 9. Seal
- 10. Spindle
- 11. Wheel stud (5 used)

Disassembly (Fig. 9)

1. Chock front wheels to prevent machine from shifting.
2. Remove rear wheel (see Wheel Removal in this section). Make sure to support machine with jack stands.
3. Remove the dust cap from the wheel hub.
4. Remove the cotter pin, retainer, jam nut and tab washer. Slide the wheel hub from the spindle shaft.
5. Pull the seal out of the wheel hub. Discard seal.
6. Remove the bearing cones from both sides of the wheel hub. Clean the bearings in solvent. Make sure the bearings are in good operating condition. Clean the inside of the wheel hub. Check the bearing cups for wear, pitting or other damage. Replace worn or damaged parts.

Assembly (Fig. 9)

1. If bearing cups were removed from the wheel hub, press new cups into the hub until they seat against the shoulder of the hub.

IMPORTANT: The lip of the seal must be toward the bearing. The seal should be pressed in so it is flush with the end of the wheel hub.

2. Pack both bearings with grease. Install one bearing into the bearing cup on inboard side of the wheel hub. Lubricate the inside of a new seal and press it into the wheel hub with the seal lip toward the bearing.

3. Fill wheel hub cavity between bearings approximately 50% full of grease. Position remaining bearing into the outer bearing cup.
4. Slide the wheel hub assembly onto the spindle shaft and secure it in place with the tab washer and jam nut. **DO NOT** fully tighten the nut or install the cotter pin.
5. While rotating the wheel hub by hand, torque the jam nut from 75 to 100 in-lb (8.5 to 11.3 N-m) to set the bearings. Then, loosen the nut until the hub has endplay.
6. While rotating the wheel hub by hand, torque the jam nut from **15 to 20 in-lb (1.7 to 2.3 N-m)**. After tightening, make sure that the wheel hub does not have any free play.
7. Install retainer with slot aligned to cotter pin hole in spindle. Install cotter pin.
8. Fill dust cap approximately half full of grease. Install dust cap.
9. Install rear wheel (see Wheel Installation in this section).
10. Lower machine to ground.
11. Torque lug nuts evenly in a crossing pattern from **70 to 90 ft-lb (95 to 122 N-m)**.

Rear Axle

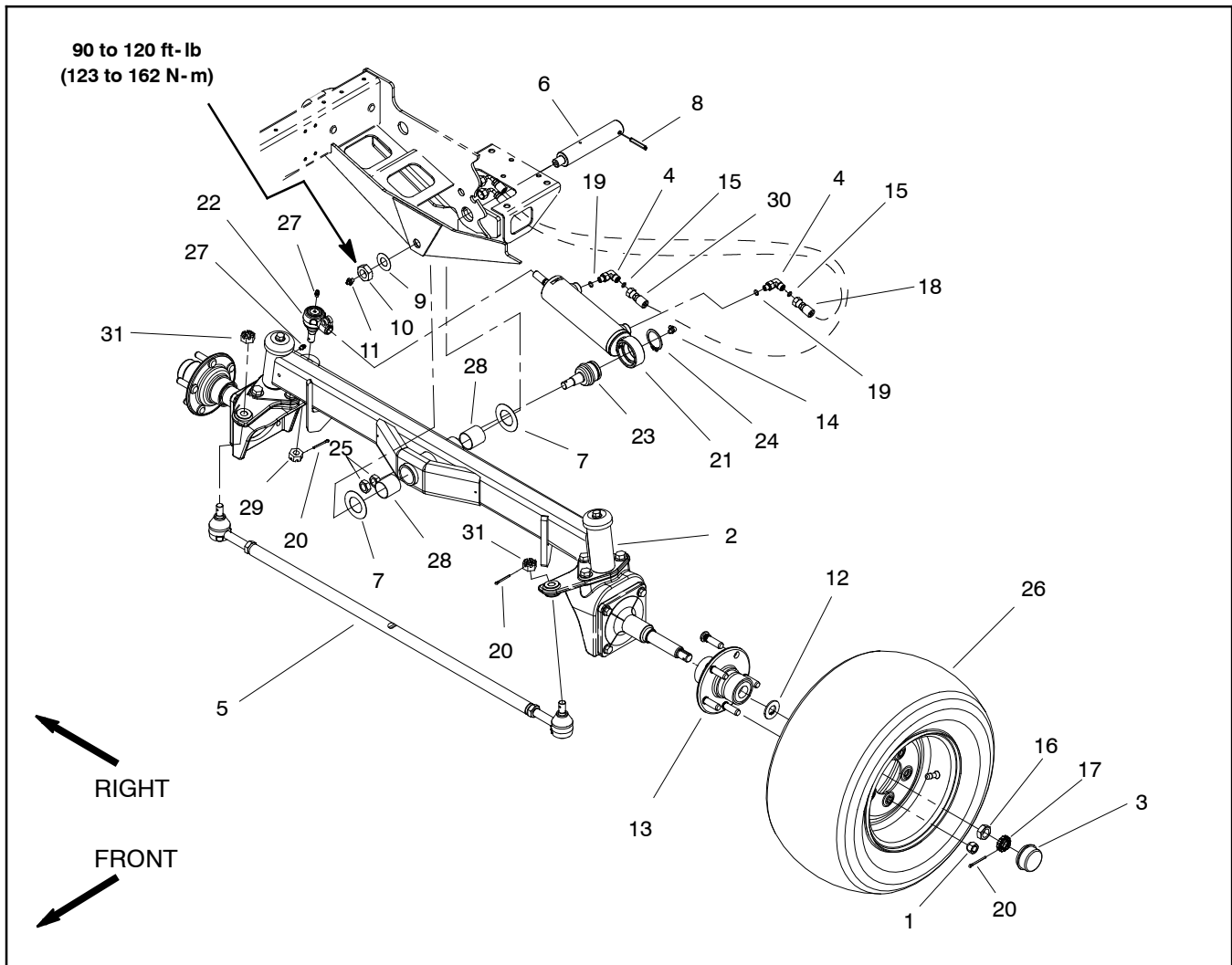

Figure 10

- 1. Lug nut (5 used per wheel)
- 2. Axle assembly
- 3. Dust cap
- 4. Hydraulic fitting
- 5. Tie rod
- 6. Axle pivot pin
- 7. Thrust washer
- 8. Roll pin
- 9. Thrust washer
- 10. Jam nut
- 11. Grease fitting

- 12. Tab washer
- 13. Wheel hub assembly
- 14. Grease fitting
- 15. O-ring
- 16. Jam nut
- 17. Nut retainer
- 18. Hydraulic hose
- 19. O-ring
- 20. Cotter pin
- 21. Steering cylinder

- 22. Ball joint
- 23. Ball joint
- 24. Retaining ring
- 25. Jam nut
- 26. Wheel assembly
- 27. Grease fitting
- 28. Bushing
- 29. Slotted hex nut
- 30. Hydraulic hose
- 31. Slotted hex nut

Removal (Fig. 10)

1. Park machine on a level surface, lower cutting units, stop engine, engage parking brake and remove key from the ignition switch.
2. Chock front wheels to prevent machine from shifting.
3. Thoroughly clean hydraulic hose ends and fittings on steering cylinder to prevent hydraulic system contamination.

NOTE: To ease assembly, label hydraulic hoses to show their correct position on the steering cylinder.

4. Disconnect the hydraulic hoses from the steering cylinder. Put caps or plugs on all fittings and hoses to prevent contamination.
5. Remove the jam nut (item 10) and thrust washer (item 9) that secure the axle pivot pin (item 6) to the frame.
6. Jack up the machine (just ahead of the rear wheels) until clearance exists to allow rear axle removal. Support the machine with jack stands or appropriate load holding device to prevent it from falling.
7. Support rear axle to prevent it from falling.
8. Pull the axle pivot pin from frame and rear axle. This will release the rear axle and thrust washers (item 7) from the frame. Carefully pull the entire axle and wheel assembly out from under the machine.

Installation (Fig. 10)

1. Thoroughly clean the rear axle pivot pin. Inspect the pin for wear or damage and replace if necessary.
2. Position the rear axle assembly to the frame. Install thrust washer (item 7) between each side of axle and frame. Raise axle assembly to frame and slide pivot pin through frame, thrust washers and axle. Make sure that roll pin on pivot pin is positioned in frame reliefs.
3. Install thrust washer (item 9) and jam nut (item 10) onto pivot pin. Torque jam nut (item 10) from **90 to 120 ft-lb (123 to 162 N-m)**. Make sure that axle can still pivot freely after jam nut is tightened.
4. Lower the machine to the ground.
5. Correctly install the hydraulic hoses to the steering cylinder.
6. Check oil level in hydraulic reservoir.
7. Lubricate the rear axle pivot bushings through the grease fitting on the axle pivot pin.
8. Operate machine and check steering cylinder hydraulic connections for leaks.

Rear Axle Service

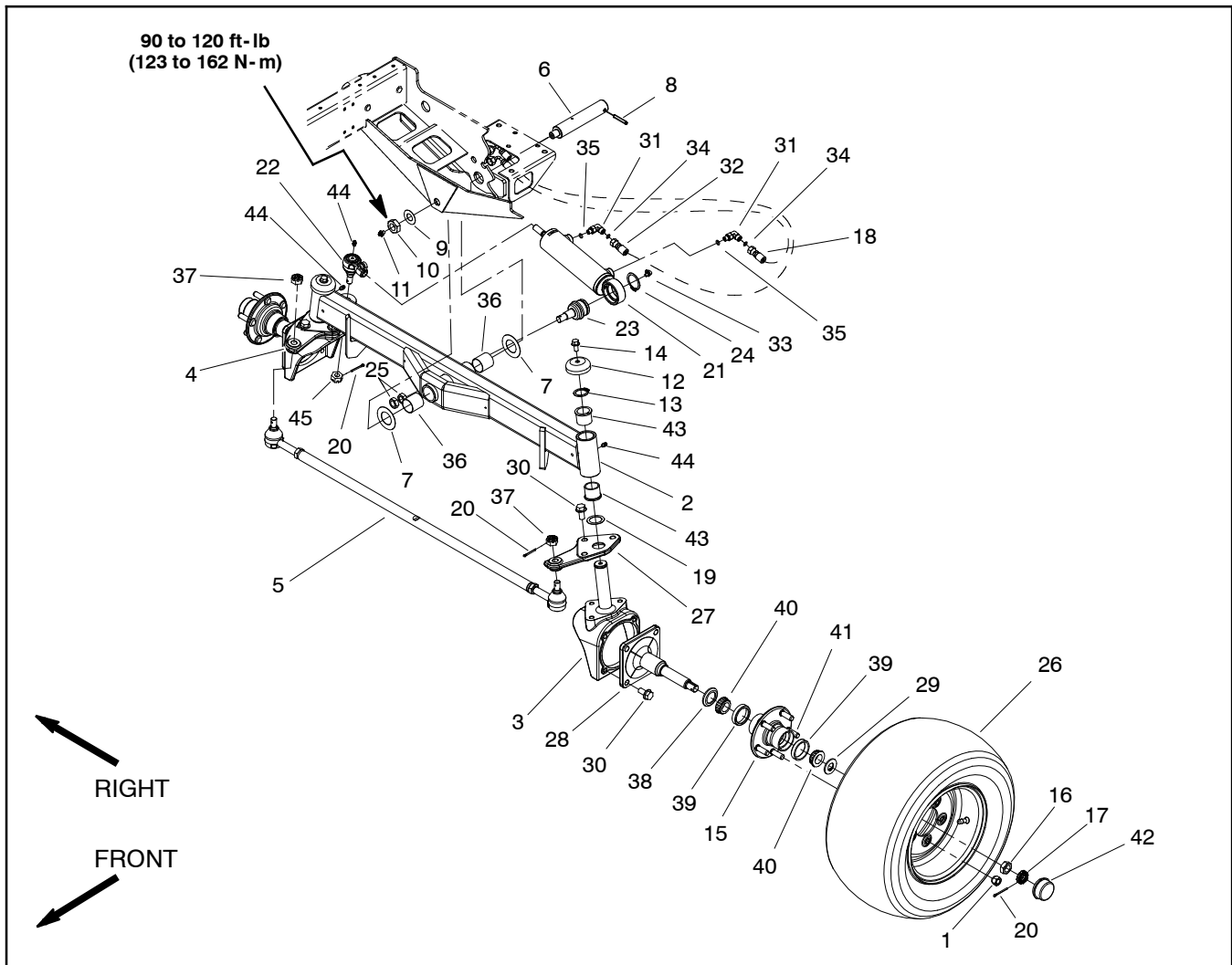

Figure 11

- | | | |
|-------------------------------|-----------------------|-----------------------------------|
| 1. Lug nut (5 used per wheel) | 16. Jam nut | 31. Hydraulic fitting |
| 2. Axle | 17. Nut retainer | 32. Hydraulic hose |
| 3. Housing | 18. Hydraulic hose | 33. Grease fitting |
| 4. RH drag link | 19. Thrust washer | 34. O-ring |
| 5. Tie rod | 20. Cotter pin | 35. O-ring |
| 6. Axle pivot pin | 21. Steering cylinder | 36. Bushing |
| 7. Thrust washer | 22. Ball joint | 37. Slotted hex nut |
| 8. Roll pin | 23. Ball joint | 38. Grease seal |
| 9. Thrust washer | 24. Retaining ring | 39. Bearing cup |
| 10. Jam nut | 25. Jam nut | 40. Bearing cone |
| 11. Grease fitting | 26. Wheel assembly | 41. Wheel stud (5 used per wheel) |
| 12. Spindle cap | 27. LH drag link | 42. Dust cap |
| 13. Retaining ring | 28. Spindle | 43. Flange bushing |
| 14. Flange head screw | 29. Tab washer | 44. Grease fitting |
| 15. Wheel hub | 30. Flange head screw | 45. Slotted hex nut |

Axle Pivot Bushings (Fig. 11)

The rear axle must be held in place snugly by the axle pivot pin. Excessive movement of the axle, which is characterized by erratic steering, might indicate worn axle pivot bushings. To correct the problem, replace the bushings (item 36).

1. Remove rear axle from machine (see Rear Axle Removal in this section).
2. Use a bushing removal tool to extract both axle pivot bushings from the axle pivot tube. Take care to not damage bore of pivot tube during bushing removal. Clean the inside of the tube to remove dirt and foreign material.
3. Apply grease to the inside and outside of the new bushings. Use an arbor press to install the bushings into the front and back of the axle pivot tube. Bushings must be flush with the axle tube.
4. Install rear axle to machine (see Rear Axle Installation in this section).

Rear Axle Spindle Bushings (Fig. 11)

The rear wheel spindles must fit snugly in the rear axle. Excessive movement of the spindle in the axle might indicate that the spindle bushings (item 43) are worn and must be replaced.

1. Remove rear axle from machine (see Rear Axle Removal in this section).
2. Remove cotter pin and slotted hex nut that secure the tie rod end to the drag link. Separate the tie rod end from the drag link.
3. If right side spindle is being removed, remove cotter pin and slotted hex nut that secure steering cylinder ball joint to drag link. Separate steering cylinder from drag link.

4. Remove the flange head screw, spindle cap and retaining ring that secure the wheel spindle into the axle tube. Slide the spindle and wheel assembly out of the axle tube to expose the spindle bushings. Locate and retrieve thrust washer (item 19) from wheel spindle shaft.

5. Use a bushing removal tool to extract both bushings from the axle tube. Take care to not damage the bore of the axle tube. Clean the inside of the axle tube to remove any dirt or foreign material.

6. Apply grease to the inside and outside of the new bushings. Use an arbor press to install the bushings into the top and bottom of the axle tube. Press bushings into tube until flange shoulder bottoms on tube.

7. Thoroughly clean the spindle shaft. Inspect the spindle for wear and replace if worn or damaged.

8. Install thrust washer (item 19) onto the spindle shaft and slide the shaft up through the axle tube. Hold the wheel and spindle shaft assembly in place and install the retaining ring (item 13) onto the end of the spindle shaft.

9. Install the spindle cap and flange head screw.

10. Connect the tie rod end to the drag link with slotted hex nut and cotter pin.

11. If separated, secure steering cylinder ball joint to drag link with slotted hex nut and cotter pin.

12. Install rear axle to machine (see Rear Axle Installation in this section).

13. Lubricate the steering spindles through the grease fittings on the rear axle.

14. Check rear wheel toe-in (see Traction Unit Operator's Manual).

15. After all adjustments have been made, make sure that no contact is made between any machine components as the wheels are moved from lock to lock. Re-adjust if necessary.

Removal (Fig. 12)

1. Park machine on a level surface, lower cutting units, stop engine, engage parking brake and remove key from the ignition switch.
2. Disconnect negative battery cable from battery (see Battery Service in the Service and Repairs section of Chapter 5 - Electrical System).
3. Disconnect seat switch electrical connector from wire harness (Fig. 13).
4. Remove two (2) flange head screws and flat washers that secure control arm assembly to seat base (Figs. 13 and 14).

IMPORTANT: Take care to not damage the throttle cable or electrical harness when removing seat and control arm assembly from machine.

5. Carefully slide control arm assembly from seat base. Locate and retrieve two (2) bushings (Fig. 14). Position and support control arm assembly to allow seat removal.
6. Remove four (4) socket head screws and flat washers that secure seat and seat base to seat adjusters.
7. Support seat base to keep it positioned on seat adjusters.
8. Remove operator seat from seat adjusters.

Installation (Fig. 12)

1. Position seat and seat base to seat adjusters.
2. Secure seat and seat base to seat adjusters with four (4) flat washers and socket head screws.

IMPORTANT: Take care to not damage throttle cable or electrical harness when installing control arm assembly to machine.

3. Make sure that two (2) bushings are positioned in control arm. Carefully slide control arm assembly onto seat base post. Secure control arm assembly to seat base with two (2) flange head screws and flat washers (Figs. 13 and 14).
4. Connect seat switch electrical connector to wire harness (Fig. 13).
5. Connect negative battery cable to battery (see Battery Service in the Service and Repairs section of Chapter 5 - Electrical System).

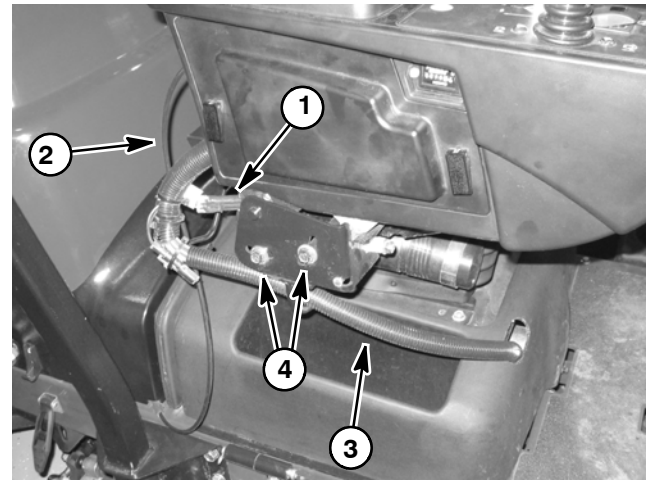

Figure 13

- | | |
|---------------------|-----------------|
| 1. Seat switch lead | 3. Wire harness |
| 2. Throttle cable | 4. Flange screw |

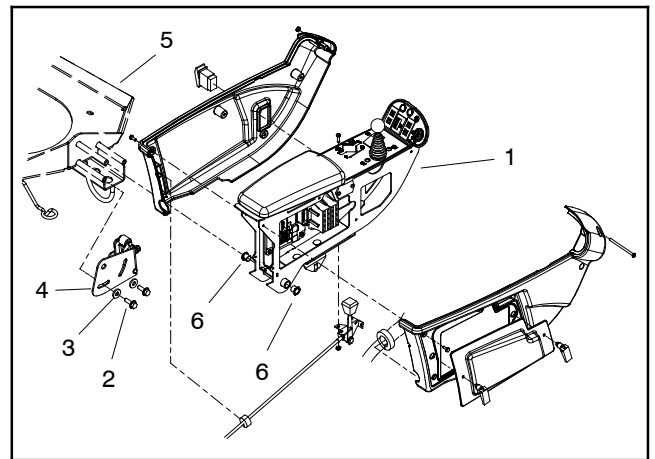

Figure 14

- | | |
|--------------------------|---------------------------|
| 1. Control arm assembly | 4. Retainer bracket assy. |
| 2. Flange screw (2 used) | 5. Seat base |
| 3. Flat washer (2 used) | 6. Bushing |

Mechanical Seat Suspension

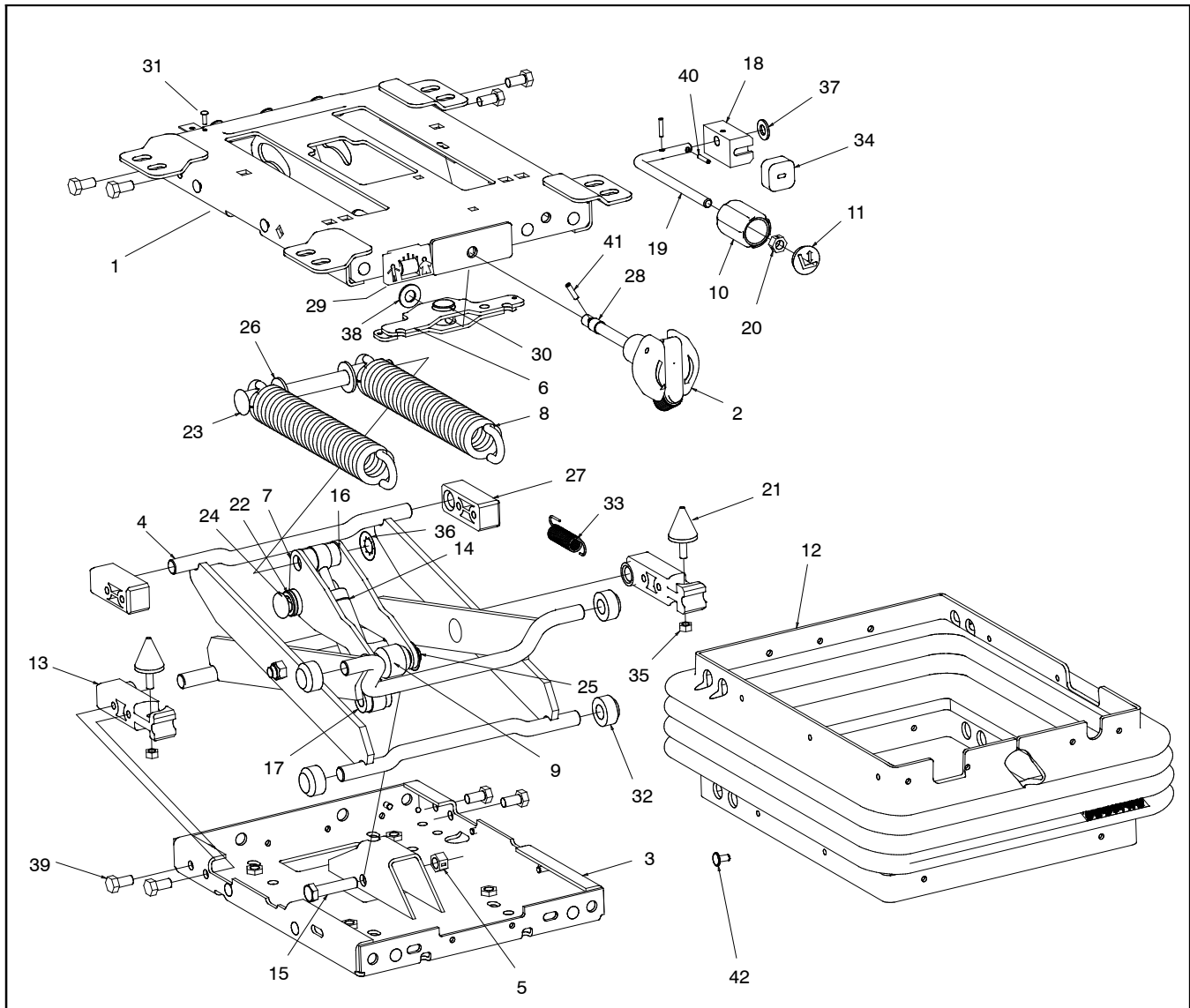

Figure 15

- | | | |
|------------------------------|----------------------------------|-----------------------------------|
| 1. Upper housing | 15. Lower shock bolt | 29. Weight indicator assembly |
| 2. Weight adjust knob | 16. Upper shock bushing (2 used) | 30. Weight adjust nut |
| 3. Lower housing | 17. Lower shock bushing (2 used) | 31. Rivet |
| 4. Scissor assembly | 18. Stop bumper | 32. Roller (4 used) |
| 5. Lock nut | 19. Height adjust rod | 33. Extension spring |
| 6. Weight adjuster | 20. Lock nut | 34. Bumper |
| 7. Drive arm | 21. Stop bumper (2 used) | 35. Hex nut (2 used) |
| 8. Extension spring (2 used) | 22. Bearing tube (2 used) | 36. Retainer (3 used) |
| 9. Roller guide | 23. Spring shaft | 37. Flat washer |
| 10. Weight adjust knob | 24. Pivot pin | 38. Flat washer |
| 11. Cap | 25. Roller pin | 39. Thread forming screw (8 used) |
| 12. Suspension boot | 26. Spring bushing (2 used) | 40. Roll pin (2 used) |
| 13. Pivot block (2 used) | 27. Shaft block (2 used) | 41. Roll pin |
| 14. Damper | 28. Weight adjust spacer | 42. Clip (20 used) |

IMPORTANT: When removing the seat suspension, make sure to support the control arm to prevent damage to the throttle cable, control arm electrical components and control arm wiring harness.

Removal (Figs. 15 and 16)

1. Park machine on a level surface, lower cutting units, stop engine, engage parking brake and remove key from the ignition switch.

2. Disconnect negative battery cable from battery (see Battery Service in the Service and Repairs section of Chapter 5 - Electrical System).

3. Remove seat from machine (see Operator Seat Removal in this section).

IMPORTANT: Take care to not damage the throttle cable or electrical harness when removing seat suspension from machine.

4. Tilt and support seat frame to allow access to seat suspension fasteners.

5. Support seat suspension to prevent it from falling. Remove four (4) flange head screws (Figure 16 item 8) and flange nuts (Figure 16 item 5) that secure seat suspension to seat frame.

6. Remove seat suspension from machine. Locate and retrieve four (4) spacers (Figure 16 item 7) from between seat suspension and seat frame.

7. Remove seat suspension components as needed using Figures 15 and 16 as guides.

Installation (Figs. 15 and 16)

1. Install all removed seat suspension components using Figures 15 and 16 as guides.

IMPORTANT: Take care to not damage the throttle cable or electrical harness when installing seat suspension to machine.

2. Position seatbase cover and four (4) spacers (Figure 16 item 7) to seat frame.

3. Position seat suspension to seat frame and secure with four (4) flange head screws (Figure 16 item 8) and flange nuts (Figure 16 item 5).

4. Install seat to machine (see Operator Seat Installation in this section). Make sure to connect harness electrical connector to the seat switch.

5. Connect negative battery cable to battery (see Battery Service in the Service and Repairs section of Chapter 5 - Electrical System).

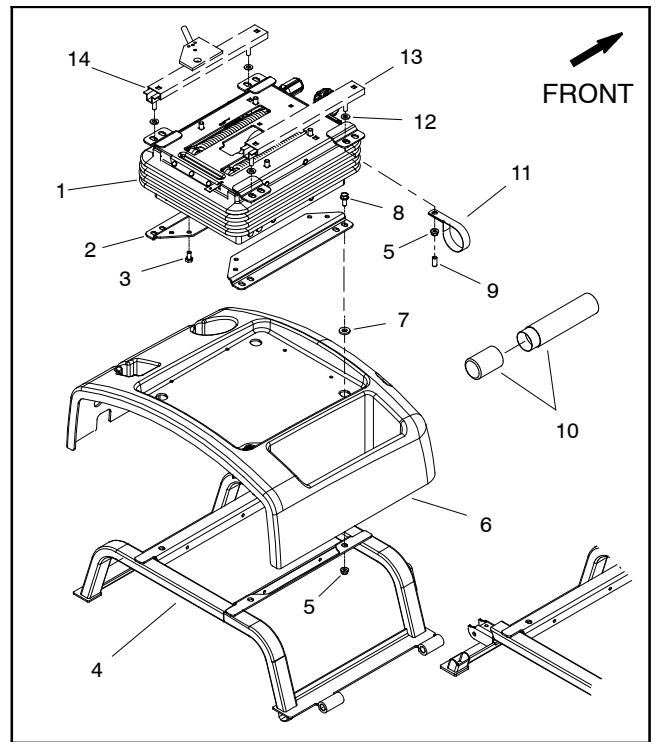

Figure 16

- | | |
|--------------------------|---------------------------|
| 1. Seat suspension | 8. Flange screw (4 used) |
| 2. Seat bracket (2 used) | 9. Cap (4 used) |
| 3. Screw (4 used) | 10. Manual tube |
| 4. Seat frame | 11. R-clamp (2 used) |
| 5. Flange nut (8 used) | 12. Flat washer (4 used) |
| 6. Seatbase cover | 13. Seat adjuster |
| 7. Spacer (4 used) | 14. Seat adjuster w/latch |

Front Lift Arms

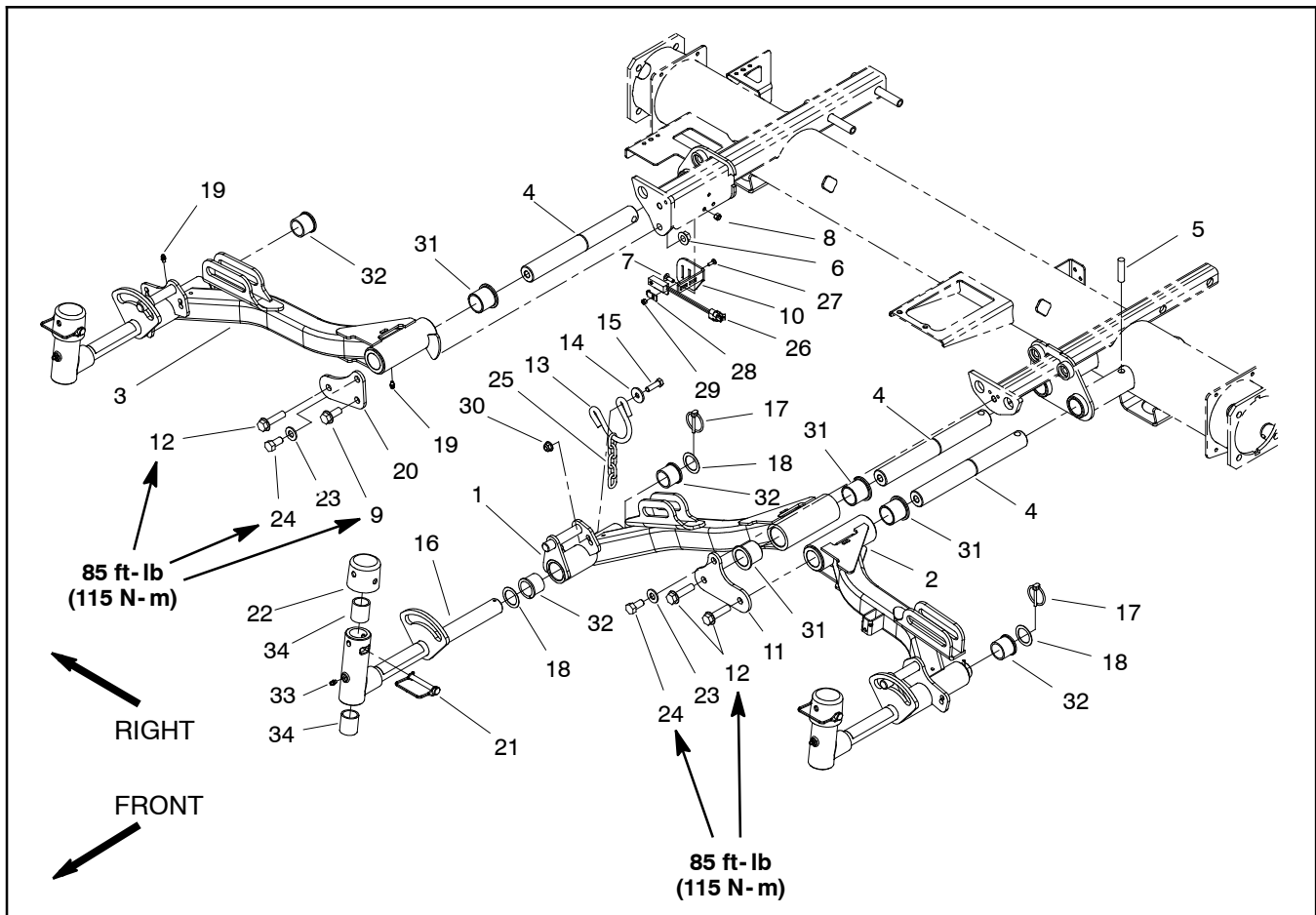

Figure 17

- | | | |
|----------------------------|--|--|
| 1. #1 lift arm | 13. Chain hoop (3 used) | 24. Cap screw (1 used per plate) |
| 2. #4 lift arm | 14. Washer (2 used per chain hoop) | 25. Chain (3 used) |
| 3. #5 lift arm | 15. Cap screw (2 used per chain hoop) | 26. Up limit switch |
| 4. Lift arm pivot shaft | 16. Pivot yoke (3 used) | 27. Carriage bolt |
| 5. Roll pin (3 used) | 17. Lynch pin (3 used) | 28. Switch plate |
| 6. Flange nut | 18. Thrust washer (2 used per yoke) | 29. Lock nut |
| 7. Carriage screw (2 used) | 19. Grease fitting (2 used per lift arm) | 30. Flange nut (2 used per chain hoop) |
| 8. Lock nut (2 used) | 20. Bridge plate | 31. Flange bushing (2 used per lift arm) |
| 9. Flange head screw | 21. Snapper pin (1 used per lift arm) | 32. Flange bushing (2 used per lift arm) |
| 10. Switch bracket | 22. Cap (1 used per lift arm) | 33. Grease fitting (1 used per yoke) |
| 11. Bridge plate | 23. Thrust washer (1 used per plate) | 34. Bushing (2 used per yoke) |
| 12. Flange screw | | |

Removal (Fig. 17)

1. Park machine on a level surface, lower cutting units, stop engine, engage parking brake and remove key from the ignition switch.
2. Remove cutting unit from front lift arm to be removed.
3. Remove one retaining ring (Fig. 18 item 3) and thrust washer (Fig. 18 item 4) from the cylinder pin (Fig. 18 item 5) that secures lift cylinder to lift arm. Pull cylinder pin from the lift cylinder and lift arm. Locate and retrieve second thrust washer.

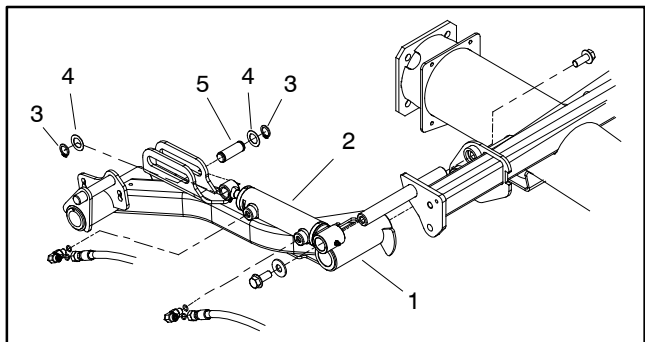

Figure 18

- | | |
|------------------------|------------------|
| 1. Lift arm (#5 shown) | 4. Thrust washer |
| 2. Lift cylinder | 5. Cylinder pin |
| 3. Retaining ring | |

4. Pivot lift cylinder rod end away from lift arm.

5. Remove lynch pin (item 17) and slide pivot yoke assembly from lift arm. Locate and retrieve two (2) thrust washers (item 18).

6. Remove fasteners that secure bridge plate to machine. The bridge plates on machines with serial numbers below 310000000 are secured with three (3) fasteners as shown in Fig. 17. On machines with serial numbers above 310000000, the bridge plates are secured with fasteners as shown in Fig. 19.

7. Slide front lift arm from lift arm pivot shaft.

8. Inspect bushings in lift arm and pivot yoke for wear or damage. If necessary, replace bushings (Figs. 20 and 21).

A. Use bushing removal tool to extract bushings from the lift arm or pivot yoke. Take care to not damage the bore.

B. Thoroughly clean the inside of the bore.

C. Apply grease to the inside and outside of the new bushings.

D. Use an arbor press to install the bushings. Lift arm bushings should be pressed until bushing flange is against lift arm bore. The upper pivot yoke bushing should be pressed fully to the shoulder in the pivot yoke bore. The lower pivot yoke bushing should be flush with the yoke tube.

Installation (Fig. 17)

1. Slide front lift arm onto pivot shaft. Secure lift arm with bridge plate. Apply medium strength threadlocker to threads of screws before installation. Tighten screws that secure bridge plate to torque values identified in Fig. 17 or 19.

2. Position thrust washer (item 18) onto pivot yoke shaft and then slide pivot yoke into lift arm bushings. Place second thrust washer on pivot yoke shaft and secure with lynch pin (item 17).

3. Align lift cylinder to lift arm mounting slot (Fig. 18). Slide cylinder pin (Fig. 18 item 5) with retaining ring (Fig. 18 item 3) and thrust washer (Fig. 18 item 4) through the lift cylinder and lift arm. Install second thrust washer on pin and secure with second retaining ring.

4. Mount cutting unit to lift arm.

5. Check operation of lift arm up limit switch and adjust if necessary (see Up Limit Switch in Components section of Chapter 5 - Electrical System).

6. Lubricate lift arm grease fittings.

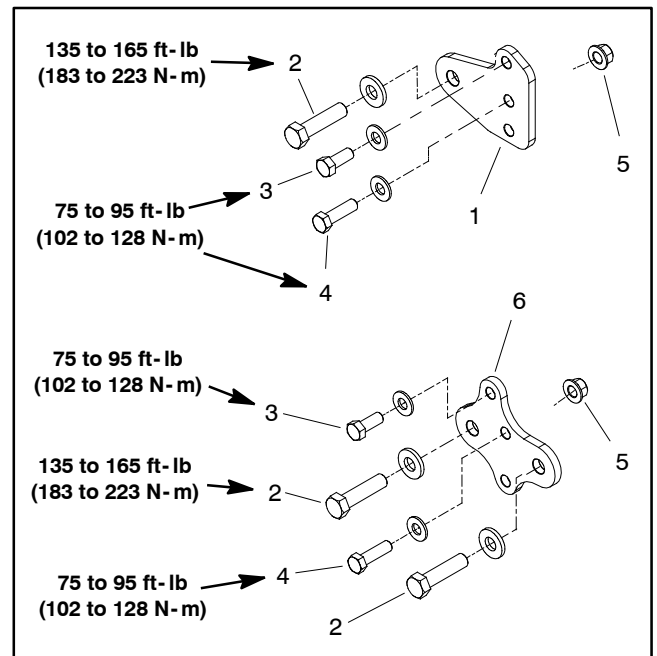

Figure 19

- | | |
|----------------------------|----------------------------|
| 1. LH bridge plate | 4. Cap screw (2 per plate) |
| 2. Cap screw | 5. Lock nut (2 per plate) |
| 3. Cap screw (1 per plate) | 6. RH bridge plate |

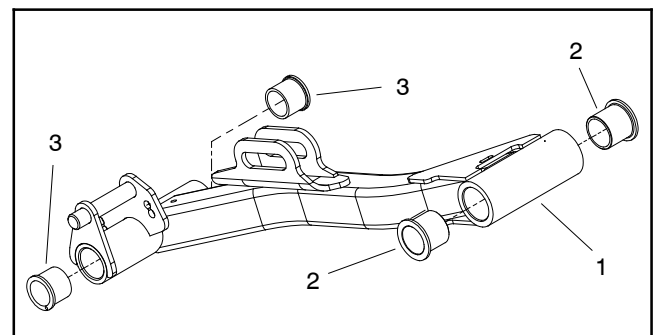

Figure 20

- | | |
|------------------------|-----------------------|
| 1. Lift arm (#1 shown) | 3. Pivot yoke bushing |
| 2. Lift arm bushing | |

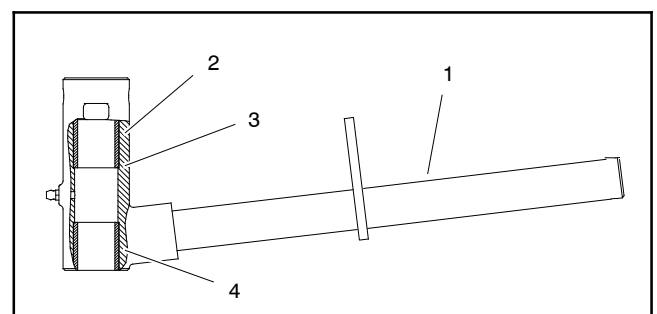

Figure 21

- | | |
|------------------|------------------------|
| 1. Pivot yoke | 3. Pivot yoke shoulder |
| 2. Upper bushing | 4. Lower bushing |

Rear Lift Arms

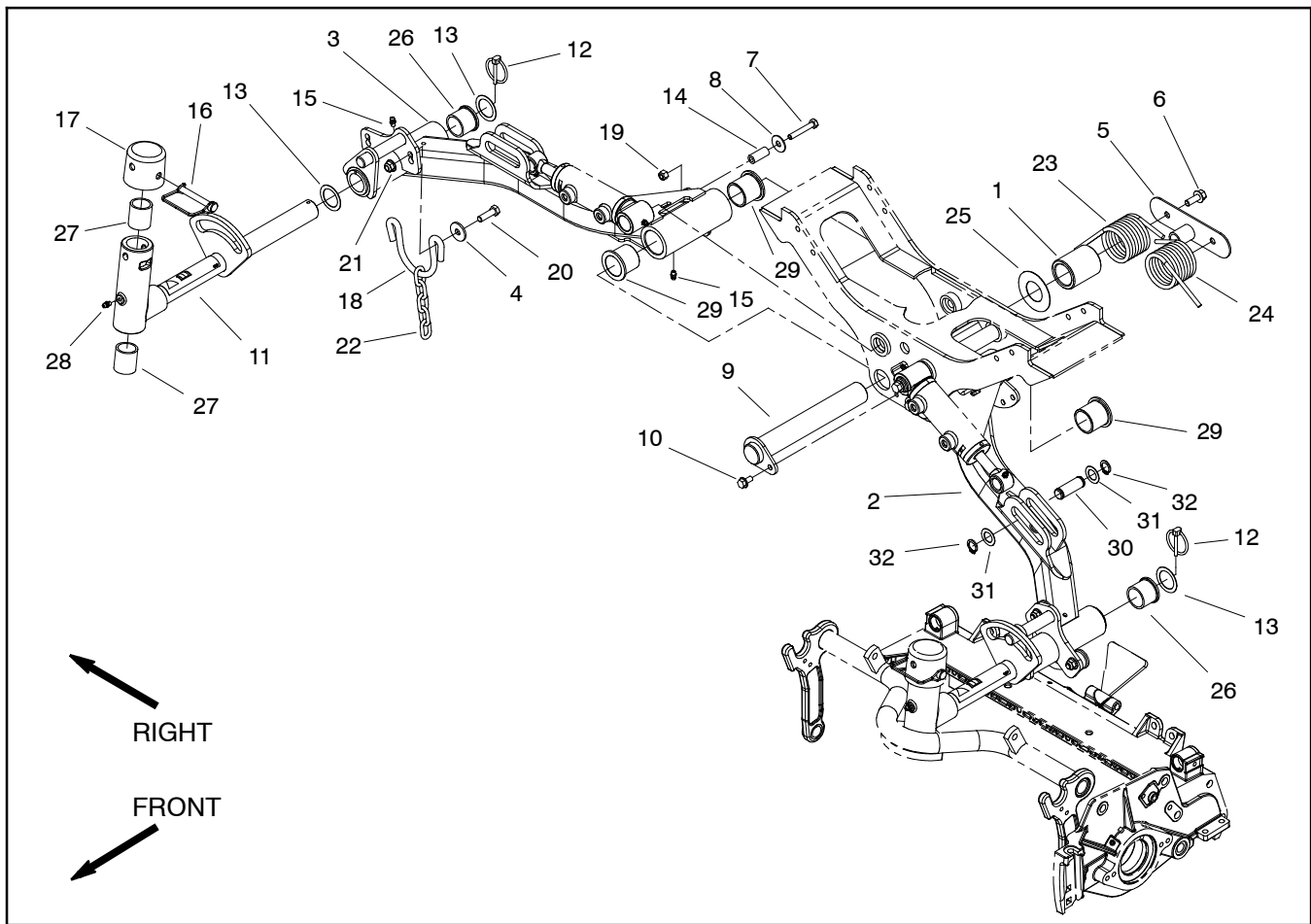

Figure 22

- | | | |
|--|--|--------------------------------------|
| 1. Spacer (2 used) | 12. Lynch pin (2 used) | 23. RH torsion spring |
| 2. #2 lift arm | 13. Thrust washer (2 used per yoke) | 24. LH torsion spring |
| 3. #3 lift arm | 14. Spacer (2 used) | 25. Washer (2 used) |
| 4. Washer (2 used per chain hoop) | 15. Grease fitting (2 used) | 26. Flange bushing (2 used per arm) |
| 5. Spring catch | 16. Snapper pin (1 used per yoke) | 27. Bushing (2 used per yoke) |
| 6. Flange head screw (2 used) | 17. Cap (1 used per yoke) | 28. Grease fitting (1 used per yoke) |
| 7. Cap screw (2 used) | 18. Chain hoop (2 used) | 29. Flange bushing (2 used per arm) |
| 8. Flat washer (2 used) | 19. Lock nut (2 used) | 30. Cylinder pin (2 used) |
| 9. Pivot pin (2 used) | 20. Cap screw (2 used per chain hoop) | 31. Thrust washer (2 used per pin) |
| 10. Washer head screw (1 used per pin) | 21. Flange nut (2 used per chain hoop) | 32. Retaining ring (2 used per pin) |
| 11. Pivot yoke (2 used) | 22. Chain (2 used) | |

Removal (Fig. 22)

1. Park machine on a level surface, lower cutting units, stop engine, engage parking brake and remove key from the ignition switch.
2. Remove cutting unit from rear lift arm to be removed.
3. Remove one retaining ring (item 32) and thrust washer (item 31) from the cylinder pin (item 30) that secures the lift cylinder rod end to lift arm. Pull cylinder pin from the lift cylinder and lift arm. Locate and retrieve second thrust washer.
4. Pivot lift cylinder rod end away from lift arm.



CAUTION

Be careful when removing tension from the torsion spring on the rear lift arms. The spring is under heavy load and may cause personal injury.

5. Remove tension from torsion spring on rear of lift arm pivot pin.

A. Insert nut driver or small piece of pipe onto the end of the torsion spring that is secured on the rear of the lift arm pivot pin.

B. Push down and rearward on the spring end to unhook the spring from the stop on the lift arm.

6. Disconnect hydraulic lift cylinder rod end clevis from lift arm (see Lift Cylinder Removal in the Service and Repairs section of Chapter 4 - Hydraulic System). Pivot lift cylinder rod end away from lift arm.

7. Remove lynch pin (item 12) and thrust washer (item 13) from rear of pivot yoke. Slide pivot yoke assembly from lift arm. Locate and retrieve front thrust washer (item 13).

8. Remove two (2) flange head screws (item 6) that secure spring catch to machine. Remove spring catch, torsion springs (items 23 and 24), two (2) spacers (item 1) and two (2) washers (item 25).

9. Remove washer head screw that secures pivot pin to frame.

10. Support rear lift arm to prevent it from falling. Slide pivot pin from frame and lift arm. Remove rear lift arm.

11. Inspect bushings in lift arm and pivot yoke for wear or damage. If necessary, replace bushings (Figs. 23 and 24).

A. Use bushing removal tool to extract both bushings from the lift arm or pivot yoke. Take care to not damage the bore.

B. Clean the inside of the bore to remove any dirt or foreign material.

C. Apply grease to the inside and outside of the new bushings.

D. Use an arbor press to install the bushings into lift arm or pivot yoke. Lift arm bushings should be pressed until bushing flange is against lift arm bore. The upper pivot yoke bushing should be pressed fully to the shoulder in the pivot yoke bore. The lower pivot yoke bushing should be flush with the yoke tube.

Installation (Fig. 22)

1. Position rear lift arm to frame and slide pivot pin through frame bosses and lift arm. Secure pin with washer head screw.

2. Place washer, spacer and torsion spring over rear of each pivot pin. Position long leg of spring forward and pointing out from top of spring.

3. Position spring catch to pivot pins and secure with two (2) flange head screws (item 6). Make sure that short end of torsion springs are against stop on spring catch.

4. Align lift cylinder rod end to lift arm mounting slot. Slide cylinder pin (item 30) with retaining ring (item 32) and thrust washer (item 31) through the lift cylinder and lift arm. Install second thrust washer on pin and secure with second retaining ring.

CAUTION

Be careful when applying tension to the torsion spring on the rear lift arms. The spring is under heavy load and may cause personal injury.

5. Apply tension to torsion springs.

A. Insert nut driver or small piece of pipe onto the long leg of the torsion spring on the rear of the lift arm pivot pin.

B. Push down and forward on the spring end to hook the spring to the stop bolt on the lift arm.

6. Mount cutting unit to lift arm.

7. Lubricate lift arm grease fittings.

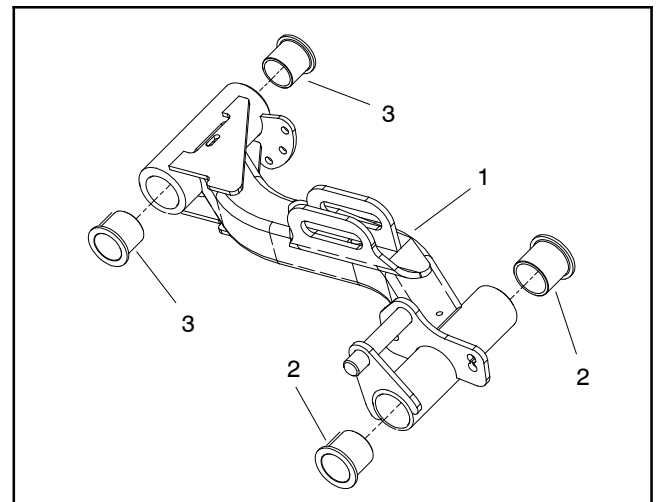

Figure 23

- 1. Rear lift arm (LH shown)
- 2. Pivot yoke bushing
- 3. Lift arm bushing

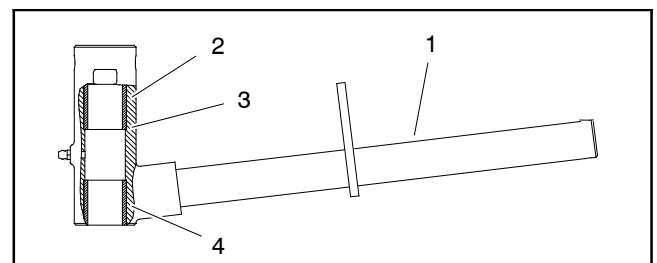

Figure 24

- 1. Pivot yoke
- 2. Upper bushing
- 3. Pivot yoke shoulder
- 4. Lower bushing

This page is intentionally blank.



DPA Cutting Units

Table of Contents

SPECIFICATIONS	2	Reel Assembly Service	
GENERAL INFORMATION	3	(cutting units with painted side plates)	28
Cutting Unit Operator's Manual	3	Reel Assembly	
SPECIAL TOOLS	4	(cutting units with aluminum side plates)	30
FACTORS THAT CAN AFFECT CUTTING		Reel Assembly Service	
PERFORMANCE	9	(cutting units with aluminum side plates)	34
SET UP AND ADJUSTMENTS	12	Preparing Reel for Grinding	36
Characteristics	12	Front Roller	37
Reel Bearing Adjustment		Rear Roller	38
(cutting units with painted side plates)	13	Roller Service	
Leveling Rear Roller	14	(greasable bearings with retaining ring)	40
SERVICE AND REPAIRS	16	Roller Service	
Hydraulic Reel Motor	16	(greasable bearings with bearing nut)	42
Backlapping	17	Rear Roller Brush – Optional	
Bedbar Assembly	18	(cutting units with painted side plates)	44
Bedknife Replacement and Grinding	20	Rear Roller Brush – Optional	
Bedbar Adjuster Service	22	(cutting units with aluminum side plates)	48
Reel Assembly			
(cutting units with painted side plates)	24		

Specifications

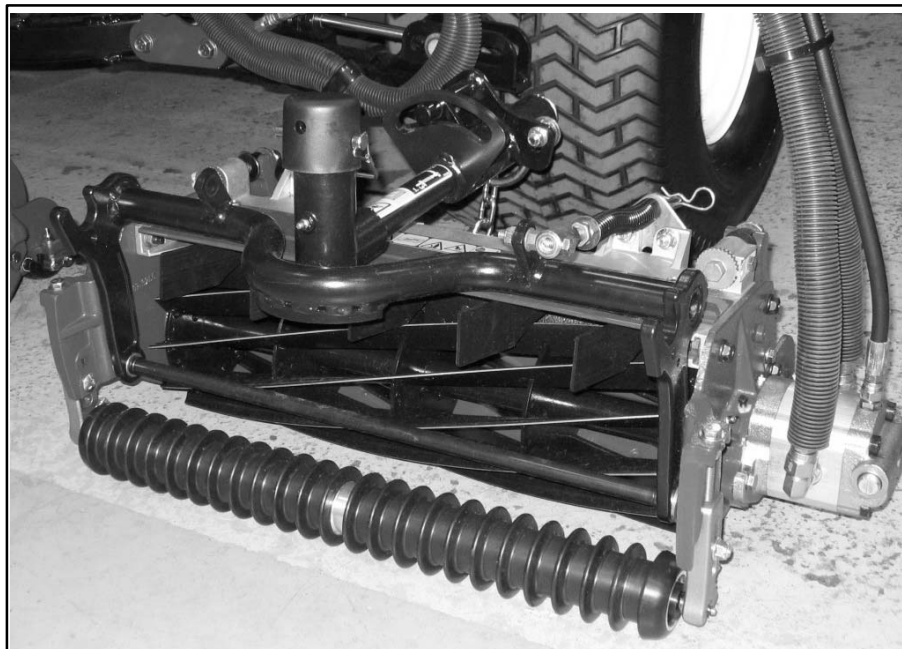

Figure 1

Frame Construction: Precision machined die cast aluminum cross member with bolt-on cast ductile iron or aluminum side plates.

Reel Construction: Reels are 22 inches (55.9 cm.) in length and are available in 5 inch (12.7 cm) and 7 inch (17.8 cm) diameters. High strength, low alloy steel blades are thru hardened and impact resistant. Reels are available in both 8 and 11 blade configurations.

Reel Bearings:

Cutting units with painted side plates have two double row, self-aligning ball bearings press fit onto reel shaft with inboard seal for protection. Reel bearing adjustment is maintained by an adjuster nut in the left side plate of the cutting unit.

Cutting units with aluminum side plates have two stainless steel sealed radial ball bearings pressed onto the reel shaft. Reel end play is maintained by an internal wave spring (no adjustment required).

Reel Drive: The reel weldment shaft is a 1 5/16 inch (33.3 mm) diameter tube with drive inserts threaded into both ends. The drive inserts for 5 inch reels have an internal eight tooth spline. The drive inserts for 7 inch reels have an internal nine tooth spline.

Height-of-Cut (HOC): Cutting height is adjusted on the front roller by two vertical screws. Effective HOC may vary depending on turf conditions, type of bedknife, roller type and installed attachments.

Bedknife: Replaceable, tool steel EdgeMax™ bedknife is fastened to a machined cast iron bedbar with 8 screws. Optional bedknives are available.

Bedknife Adjustment: Dual screw assemblies allow for precise bedknife adjustment. Adjustment detents correspond to bedknife movement for each indexed position as follows:

- 0.0007 inch (0.018 mm) for 5 inch reel
- 0.0009 inch (0.022 mm) for 7 inch reel

Front and Rear Rollers: Greaseable through-shaft front and rear rollers are used with these cutting units. All rollers use the same heavy duty, stainless steel ball bearings and seal package.

Counterbalance Weight: A cast iron weight or a groomer and/or a powered rear roller brush accessory is mounted opposite to the hydraulic drive motor to balance the cutting unit.

Cutting Unit Weight:

8 Blade, 5" reel	112 lb. (51 kg)
8 Blade, 7" reel	145 lb. (66 kg)
11 Blade, 7" reel	151 lb. (69 kg)

Options:

Refer to Cutting Unit Parts Catalog for available options for your Reelmaster cutting unit.

General Information

Cutting Unit Operator's Manual

The Cutting Unit Operator's Manual provides information regarding the operation, general maintenance and maintenance intervals for the cutting units on your Reelmaster machine. Additionally, if optional kits have been installed on the cutting units (e.g. groomer, rear roller brush), the installation instructions for the kit includes set-up and operation information. Refer to those publications for additional information when servicing the cutting units.

Special Tools

Order Special Tools from your Toro Distributor. Some tools may have been supplied with your machine or are available as TORO parts.

Gauge Bar Assembly

Toro Part Number: **108-6715**

Use gauge bar to verify height-of-cut adjustment. Also used for adjustment of optional groomer.

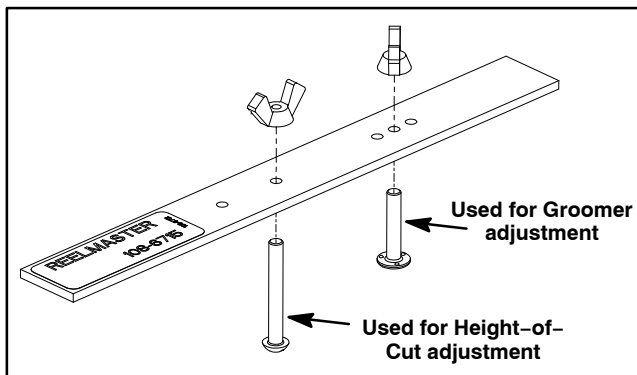

Figure 2

Bedknife Screw Tool

Toro Part Number: **TOR510880**

This screwdriver-type bit is made to fit Toro bedknife attaching screws. Use this bit with a torque wrench to secure the bedknife to the bedbar.

IMPORTANT: To prevent damage to the bedbar, **DO NOT** use an air or manual impact wrench with this tool.

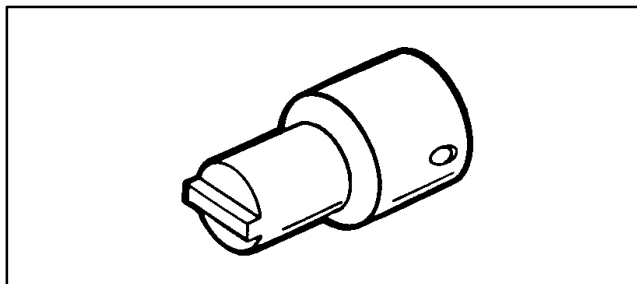

Figure 3

Handle Assembly

Toro Part Number: **29-9100**

For applying lapping compound to cutting units while keeping hands a safe distance from the rotating reel.

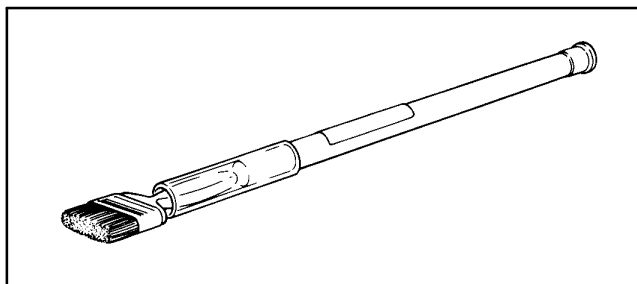

Figure 4

Plastic Plug

Toro Part Number: **2410-30** (for 5 inch reels)
94-2703 (for 7 inch reels)

This cap is used for placement into the side plate bearing housing when the hydraulic reel motor is removed. It prevents dirt and debris from entering the cutting reel bearing area.

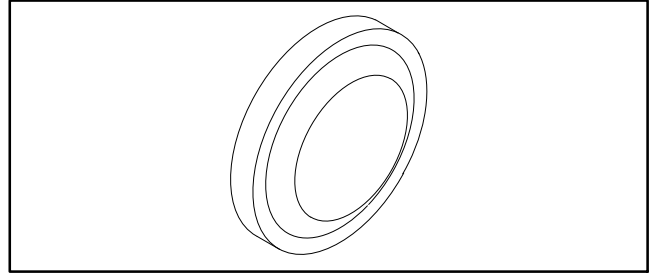

Figure 5

Cutting Unit Kickstand

Toro Part Number: **119-8010-03**

The cutting unit kickstand is used to prop up the front of the cutting unit during service. Use of this tool prevents the bedbar adjusting screws from resting on the work surface.

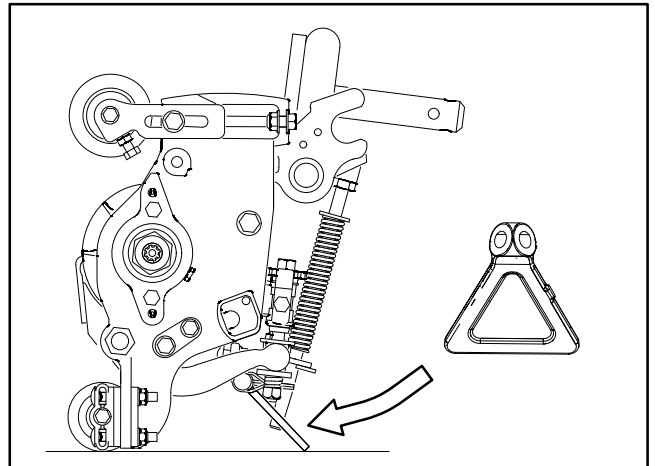

Figure 6

Spline Insert Tool

Toro Part Number: **TOR4112** (8 tooth for 5 inch reels)
TOR4074 (9 tooth for 7 inch reels)

Use spline insert tool for rotating cutting reel when hydraulic motor is removed. Also use this tool for installation of threaded inserts into cutting reel shaft.

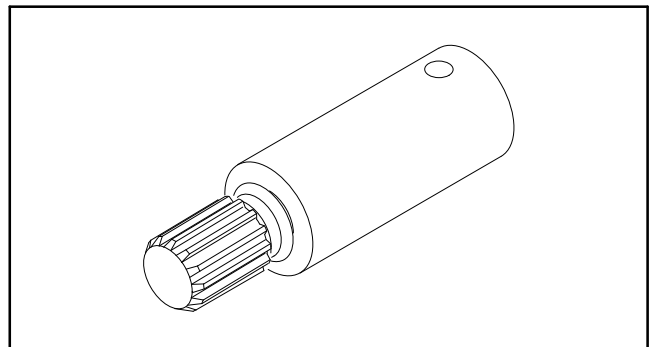

Figure 7

Rear Roller Bearing and Seal Installation Tools

These tools are used to assemble the cutting unit roller that has greasable bearings and a bearing lock nut used to retain the bearings.

- 115-0852 Inner Seal Tool
- 115-0853 Bearing/Outer Seal Tool
- 107-8133 Bearing Installation Washer

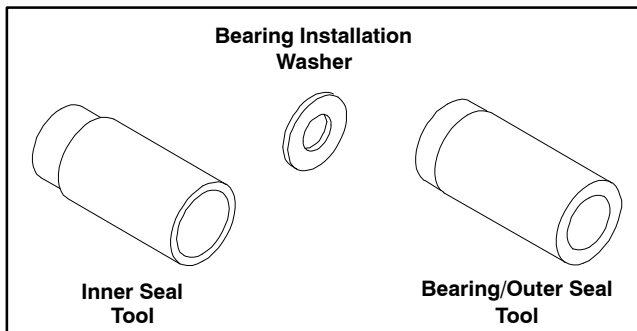

Figure 8

Turf Evaluator Tool

Toro Model Number: **04399**

Many turf discrepancies are subtle and require closer examination. In these instances, the Turf Evaluator grass viewing tool is helpful. It can assist turf managers and service technicians in determining causes for poor reel mower performance and in comparing the effective height-of-cut of one mowed surface to another. This tool should be used with the Toro Guide to Evaluation Reel Mower Performance and Using the TurfEvaluator (Toro part no. 97931SL)



Figure 9

Diameter/Circumference Measuring Tape

Toro Part Number: **TOR6023**

Spring steel measuring tape for accurately measuring the circumference and outside diameter of cutting reel and other spherical components. Tape calibration is in fixed inch readings (no adjustments).



Figure 10

Reel Bearing Installation Tool (cutting units with painted side plates)

Toro Part Number: **117-0975**

Use the reel bearing installation tool to keep the reel bearing aligned as the cutting unit side plate is installed on the bearing.

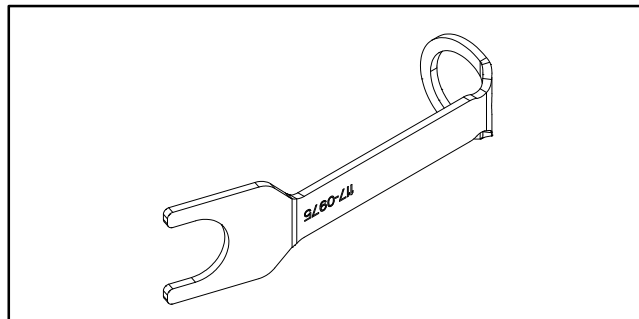

Figure 11

Cutting Reel Shim

Toro Part Number: **125-5611**

The cutting reel shim (0.002") is used to help parallel the bedknife and cutting reel.

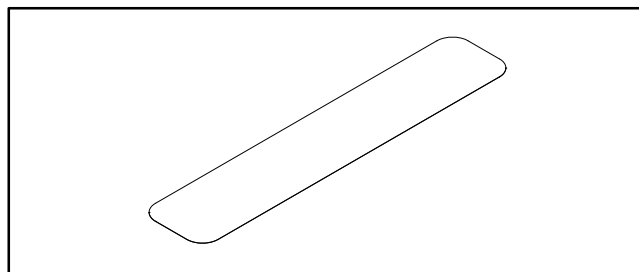

Figure 12

Cutting Performance Paper

Toro Part Number: **125-5610**

Cutting performance paper is used to test the cutting reel performance after adjusting the reel to bedknife clearance. 10 packs (30 strips per pack) of cutting performance paper are included in this part number.

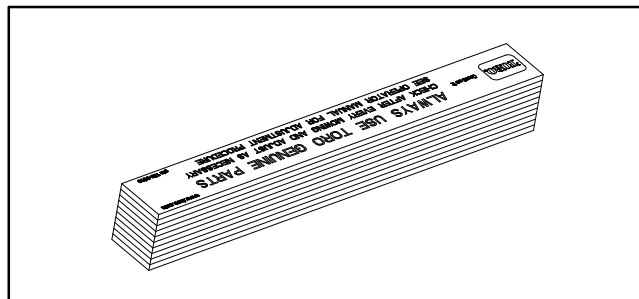

Figure 13

Pulley Alignment Tool

Toro Part Number: **114-5446**

Use pulley alignment tool to verify alignment of groomer and/or rear roller brush drive and driven pulleys.

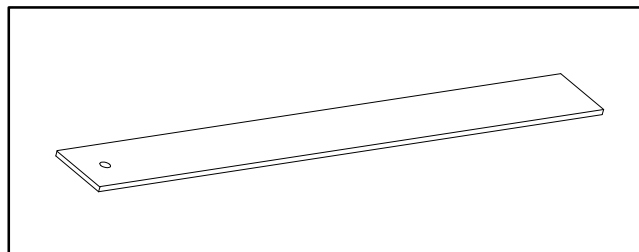

Figure 14

Bedknife Top Angle Indicator and Mount

Toro Part Numbers: **131-6828** and **131-6829**

Because the top grind angle on bedknives is critical for edge retention, and therefore after-cut appearance, Toro has developed these service tools for accurately measuring the top grind angle on all bedknives.

Since there can be variations in the mounting surface of the bedbar, it is necessary to grind the bedknife after installing it to the bedbar.

1. Place the angle indicator on the bottom side of the bedknife with the digital display facing you as shown (Fig. 15).

2. Press the Alt Zero button on the angle indicator.

3. Remove the angle indicator and place the angle-indicator mount on the edge of the bedknife so the face of the magnet is flat against the top of the bedknife (Fig. 16).

4. Place the angle indicator on the mount with the digital display facing you as shown (Fig. 16). The angle displayed on the indicator is the current bedknife top angle. The angle measured should be between 8° and 12°.

NOTE: Some bedknives were produced with a 5° top angle. Use a 10° top angle when regrinding all bedknives.

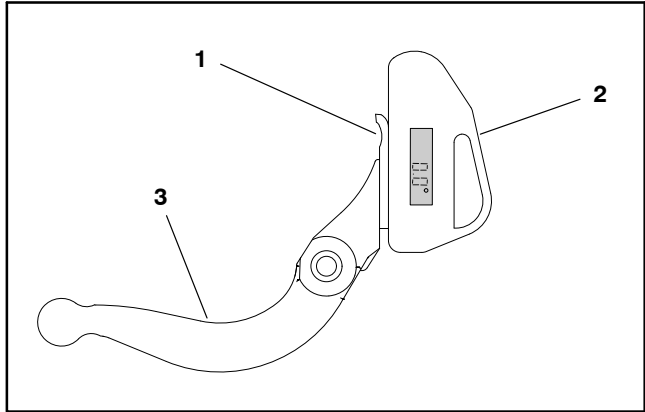

Figure 15

- 1. Bedknife
- 2. Angle indicator
- 3. Bedbar

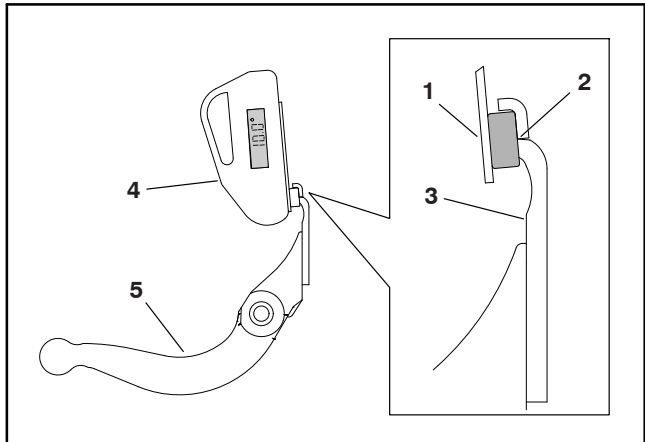

Figure 16

- 1. Angle indicator mount
- 2. Magnet
- 3. Bedknife
- 4. Angle indicator
- 5. Bedbar

Factors That Can Affect Cutting Performance

There are a number of factors that can contribute to unsatisfactory quality of cut, some of which may be turf conditions. Turf conditions such as excessive thatch, “sponginess” or attempting to cut off too much grass height may not always be overcome by adjusting the cutting unit. It is important to remember that the lower the height-of-cut, the more critical these factors are.

Refer to the Cutting Unit’s Operator’s Manual for detailed cutting unit adjustment procedures. For cutting unit repair information, refer to the Service and Repairs section of this chapter.

NOTE: For additional information regarding cutting unit troubleshooting, see **Aftercut Appearance Troubleshooting Aid (Toro part no. 00076SL)**.

Factor	Possible Problem/Correction
Tire pressure	<p>Check tire pressure of all traction unit tires. Adjust tire pressure as necessary.</p> <p>See the Traction Unit Operator’s manual and Chapter 6 – Chassis in this manual.</p>
Governed engine speed	<p>For best cutting performance and appearance, engine should be run at maximum governed speed during machine operation. Check maximum governed engine speed. Adjust engine to specifications if necessary.</p> <p>See the Traction Unit Operator’s Manual and Chapter 3 – Kubota Diesel Engine in this manual.</p>
Reel speed	<p>All cutting reels must rotate at the same speed (within 100 rpm) (see Troubleshooting in Chapter 4 – Hydraulic System in this manual).</p> <p>All cutting units must have equal bedknife to reel and height-of-cut adjustments.</p> <p>Make sure that reel speed selection is correct (see Clip Chart in Traction Unit Operator’s Manual).</p>
Reel bearing condition	<p>Check reel bearings for wear and replace if necessary.</p> <p>See Reel Assembly in the Service and Repairs section of this chapter.</p>
Bedknife to reel adjustment	<p>Check bedknife to reel contact daily. The bedknife must have light contact across the entire reel. No contact will dull the cutting edges. Excessive contact accelerates wear of both edges. Quality of cut is adversely affected by both conditions (see Bedknife to Reel Adjustment in the Cutting Unit Operator’s Manual).</p>

DPA Cutting Units

Factor	Possible Problem/Correction
<p>Reel and bedknife sharpness</p> <p>NOTE: After grinding the reel and/or bedknife, check the reel to bedknife contact again after cutting two (2) fairways. During this initial use, any burrs will be removed from reel and bedknife which may create improper reel to bedknife clearance and thus accelerate wear. This practice of re-checking the reel to bedknife contact after grinding will extend the longevity of the sharpness of the edge of the reel and the bedknife.</p>	<p>A reel and/or bedknife that has rounded cutting edges or “rifling” (grooved or wavy appearance) cannot be corrected by tightening the bedknife to reel contact. Grind cutting reel to remove taper and/or rifling. Grind bedknife to sharpen and/or remove rifling.</p> <p>The most common cause of rifling is bedknife to reel contact that is too tight.</p> <p>Dull cutting edges must be corrected by grinding the bedknife and cutting reel (see Preparing Reel for Grinding in the Service and Repairs section of this chapter).</p> <p>A new bedknife must be ground flat (within 0.002”) after installation to the bedbar. Backlapping may be required to properly mate the reel and bedknife after installation into the cutting unit.</p> <p>NOTE: On cutting units equipped with optional bedknives, slightly dull cutting edges may be corrected by backlapping (see Backlapping in the Service and Repairs section of this chapter).</p>
<p>Rear roller adjustment</p>	<p>Adjust the rear roller brackets to correct position depending on the height-of-cut range and aggressiveness of cut that is desired.</p> <p>See Rear Roller Adjustment in the Cutting Unit Operator’s Manual.</p>
<p>Height-of-cut</p>	<p>“Effective” or actual height-of-cut depends on the cutting unit weight and turf conditions. Effective height-of-cut will be different from the bench set height-of-cut.</p> <p>See Height-of-Cut Adjustment in the Cutting Unit Operator’s Manual.</p>
<p>Proper bedknife selection for height-of-cut desired</p>	<p>If the bedknife is incorrect for effective height-of-cut, poor quality of cut will result.</p> <p>See Cutting Unit Operator’s Manual for bedknife options.</p>
<p>Stability of bedbar</p>	<p>Make sure bedbar pivot bolts are seated securely. Check condition of the bushings in the side plates.</p> <p>See Bedbar Assembly in the Service and Repairs section of this chapter.</p>
<p>Number of reel blades</p>	<p>Use correct number of reel blades for clip frequency and optimum height-of-cut range.</p>
<p>Cutting unit alignment and carrier frame ground following</p>	<p>Check carrier frames and lift arms for damage, binding conditions or bushing wear. Repair if necessary.</p>

Factor	Possible Problem/Correction
Roller condition and roller type	<p>Make sure rollers rotate freely. Repair roller bearings as necessary.</p> <p>See Roller Service in the Service and Repairs section of this chapter.</p> <p>Refer to Cutting Unit Operator's Manual for roller options.</p>
Turf compensation spring adjustment	Refer to Traction Unit Operator's Manual for adjustment procedure.
Rear lift arm counterbalance spring adjustment	Refer to Traction Unit Operator's Manual for adjustment procedure.
Cutting unit accessories	A variety of cutting unit accessories are available that can be used to enhance aftercut appearance. Refer to Operator's Manual for a listing of available accessories.

Set Up and Adjustments

Characteristics



CAUTION

Never install or work on the cutting units or lift arms with the engine running. Always stop engine and remove key first.

The dual knob bedknife-to-reel adjustment system incorporated in this cutting unit simplifies the adjustment procedure needed to deliver optimum mowing performance. The precise adjustment possible with this design gives the necessary control to provide a continual self-sharpening action. This feature maintains sharp cutting edges, assures good quality of cut and greatly reduces the need for routine backlapping.

In addition, the rear roller positioning system allows for various height-of-cut ranges and aggressiveness of cut selections.

If a cutting unit is determined to be out of adjustment, complete the following procedures in the specified order to adjust the cutting unit properly.

1. Adjust the bedknife parallel to the reel.
2. Determine desired height-of-cut range and install rear roller mounting shim(s) accordingly.
3. Adjust the height-of-cut.

See Cutting Unit Operator's Manual for cutting unit adjustment procedures for your Reelmaster.

Reel Bearing Adjustment (cutting units with painted side plates)

NOTE: Cutting units that have aluminum side plates do not require reel bearing adjustment.

To insure cut quality and long life of the cutting reel bearings, periodically check reel bearing adjustment.

Check Reel Bearing Adjustment

1. Remove hydraulic reel motor from cutting unit (see Hydraulic Reel Motor Removal in the Service and Repairs section of this chapter).
2. Loosen bedknife to reel adjustment until no contact exists (see Cutting Unit Operator's Manual).

**CAUTION**

Contact with the reel, bedknife or other cutting unit parts can result in personal injury. Use heavy gloves when handling the cutting reel.

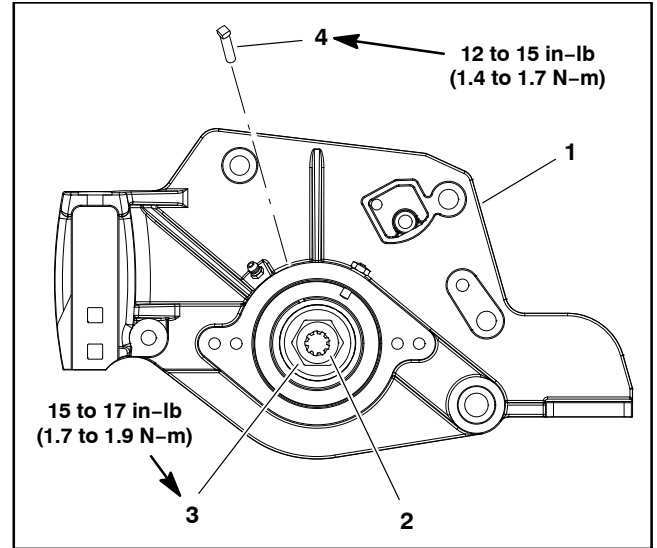

Figure 17

- | | |
|--------------------|-------------------------|
| 1. LH side plate | 3. Bearing adjuster nut |
| 2. Threaded insert | 4. Set screw |

3. Hold on to the reel shaft and try to move the reel assembly side to side. If reel end play exists, side to side movement will be detected.

4. Using a suitable torque wrench and spline insert tool (see Special Tools), measure the rolling resistance of the cutting reel. Cutting reel rolling torque should not exceed 10 in-lb (1.1 N-m).

5. If reel has end play or if rolling torque is incorrect, perform reel bearing adjustment (see below).

6. After checking or adjusting reel bearings, adjust cutting unit (see Cutting Unit Operator's Manual).

7. Install hydraulic reel motor to cutting unit (see Hydraulic Reel Motor Installation in the Service and Repairs section of this chapter).

Reel Bearing Adjustment (Fig. 17)

1. Make sure that no contact exists between bedknife and reel.

2. Remove cutting unit components on LH side plate to allow access to bearing adjuster nut. If cutting unit is equipped with a rear roller brush, refer to Rear Roller Brush (Optional) in the Service and Repairs section of this chapter. If cutting unit is equipped with a groomer, refer to Chapter 8 – Belt Driven Groomer.

3. Loosen set screw that secures bearing adjuster nut in LH side plate of cutting unit.

IMPORTANT: Over tightening reel bearing adjuster nut may damage reel bearings.

4. With the cutting unit and reel in a horizontal position, use a 1 3/8" socket and torque wrench to overtighten the bearing adjuster nut to **25 in-lb (2.8 N-m)**.

5. Loosen the bearing adjuster nut and then torque bearing adjuster nut from **15 to 17 in-lb (1.7 to 1.9 N-m)**.

6. Using a suitable torque wrench and spline insert tool (see Special Tools), check that reel rolling torque does not exceed 10 in-lb (1.1 N-m). Also, check if reel bearing endplay exists. If endplay exists, replace the cutting reel bearings and seals (see Reel Assembly and Reel Assembly Service in the Service and Repairs section of this chapter).

7. Apply Loctite #243 (or equivalent) to threads of set screw and secure bearing adjuster nut in place with set screw. Torque set screw from **12 to 15 in-lb (1.4 to 1.7 N-m)**.

8. After reel bearing adjustment, install all removed cutting unit components to cutting unit.

Leveling Rear Roller

The precision machined components of the cutting unit frame keep the rear roller and cutting reel in alignment (parallel). If the side plates are disassembled or as the cutting reel wears, a limited amount of side plate adjustment is possible to make sure that the cutting unit is properly aligned.

1. Place the assembled cutting unit on a surface plate.
2. Make sure that bedknife is properly adjusted to cutting reel.
3. Check if the rear roller is level to the cutting reel by using a 0.005" (0.13 mm) feeler gauge to determine the clearance between the surface plate and the rear roller at each end of the roller. As the rear roller is rotated one full turn, check if the feeler gauge will consistently pass under the roller at one end but will not pass under the opposite end. Check rear roller with the feeler gauge just inside the machined ends of the roller. A frame adjustment should be made if there is consistently more than 0.005" (0.13 mm) clearance under the roller on one end but not on the other.

NOTE: Cutting units with 5" diameter reel use two (2) shoulder bolts to secure side plates to frame. Cutting units with 7" diameter reel use three (3) shoulder bolts to secure side plates to frame.

4. Loosen, but do not remove, shoulder bolts that secure the side plate to the frame opposite the side that is not level (Fig. 18).
5. Adjust the position of the side plate to parallel the rear roller and cutting reel. Then, tighten the shoulder bolts to a torque from **27 to 33 ft-lb (37 to 44 N-m)**.
6. After tightening the side plate, recheck the rear roller. If necessary, loosen and adjust second side plate.
7. If rear roller is still not level after adjusting both side plates, check to see if cutting reel is tapered (see Preparing Reel for Grinding in the Service and Repairs section of this chapter). If cutting reel is not tapered and rear roller is not level, a 0.010" shim (part number 107-4001) is available to allow additional rear roller adjustment. The shim would be used on one side of the rear roller and should be installed between the rear roller bracket and roller shim (Fig. 19).
8. After leveling rear roller, complete cutting unit set-up and adjustment sequence.

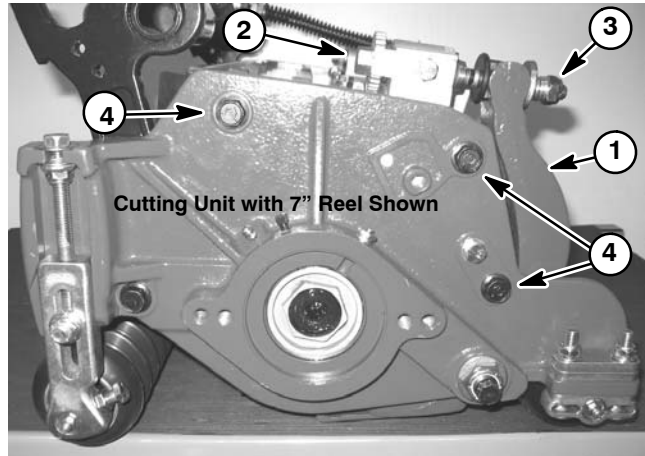

Figure 18

- | | |
|--------------------------|----------------------------|
| 1. Bedbar | 3. Spring tension lock nut |
| 2. Bedbar adjuster screw | 4. Shoulder bolt |

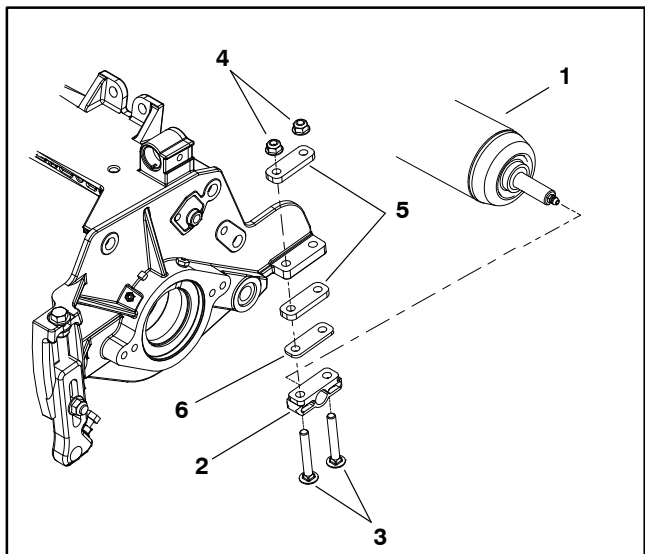

Figure 19

- | | |
|-------------------------|----------------------------|
| 1. Rear roller assembly | 4. Flange nut |
| 2. Rear roller bracket | 5. Roller shim |
| 3. Carriage screw | 6. 0.010" shim (if needed) |

This page is intentionally blank.

Service and Repairs

Hydraulic Reel Motor

IMPORTANT: When performing maintenance procedures on the cutting units, carefully position the cutting unit reel motors to prevent damage to the motors or hydraulic hoses.

Removal

1. Park machine on a clean and level surface, lower cutting units completely to the ground, stop engine, engage parking brake and remove key from the ignition switch.

2. Loosen two (2) cap screws that secure the hydraulic reel motor to the cutting unit side plate. Rotate motor clockwise and remove motor.

3. Place protective plastic cap (see Special Tools) into the hole in the cutting unit side plate to prevent debris entry into reel bearing area.

Inspection

1. Check reel insert splines for wear. Replace if necessary (see Reel Assembly in the Service and Repairs section of this chapter).

Installation

NOTE: Refer to Figure 20 for correct placement of cutting unit reel motors and weights.

1. Coat spline shaft of the reel motor with No. 2 multi-purpose lithium base grease.

2. Install the cap screws for the reel drive motor into the cutting unit side plate and leave approximately 1/2 inch (12.7 mm) of threads exposed on each screw.

3. Rotate the motor clockwise so the motor flanges clear the cap screws in the cutting unit side plates. Align reel motor shaft splines with cutting reel insert splines. Slide motor shaft into reel insert.

4. Rotate the motor counterclockwise until the motor flanges are encircling the cap screws. Tighten two (2) cap screws to secure reel motor to cutting unit.

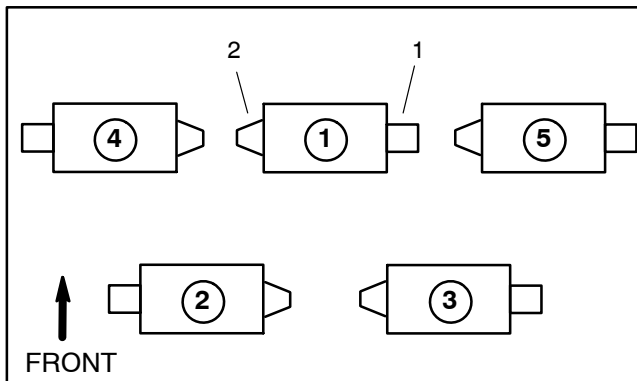

Figure 20

- 1. Reel motor location
- 2. Weight location

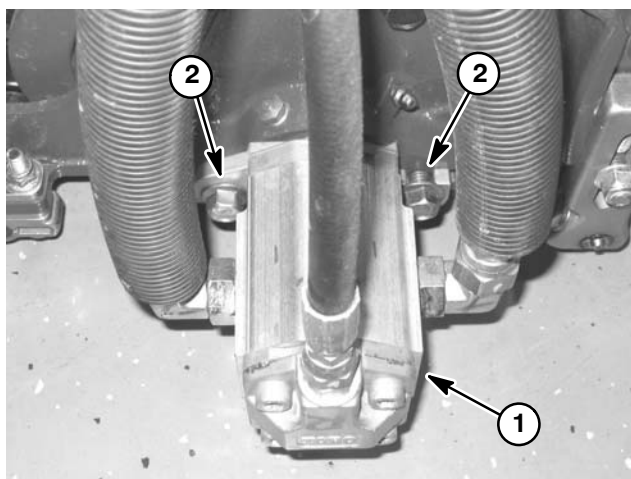

Figure 21

- 1. Hydraulic reel motor
- 2. Cap screws

Backlapping

DANGER

TO AVOID PERSONAL INJURY OR DEATH:

- Never place hands or feet in the reel area while the engine is running.
- While backlapping, the reels may stall and then restart.
- Do not attempt to restart reels by hand or foot.
- Do not adjust reels while the engine is running.
- If a reel stalls, stop engine before attempting to clear the reel.
- Reel motors are connected in series: rotating one motor causes rotation in other motors.

1. Position machine on a clean and level surface, lower cutting units, stop engine, engage parking brake and remove key from the ignition switch.

2. On all cutting units, make initial reel to bedknife adjustments appropriate for backlapping.

IMPORTANT: Do not attempt to rotate the directional valve lever on the hydraulic mow control manifold when the engine or reels are running.

3. Raise seat, locate hydraulic mow control manifold and rotate directional valve lever fully to the R (backlap) position (Fig. 22). Rotate flow control valve knob to position 1.

4. Start engine and run at low idle speed (1150 to 1350 RPM).

5. Press PTO switch to engage and move RAISE/LOWER-MOW control forward to start the cutting reels.

6. Apply lapping compound to cutting reel blades with a long handled brush (see Special Tools). While backlapping, occasionally move brush across reel to distribute compound.

CAUTION

Be careful when backlapping the reel because contact with the reel or other moving parts can result in personal injury.

7. To make a cutting unit adjustment while backlapping, turn reels OFF, shut off engine and wait for all machine and cutting unit motion to completely stop. Then, after cutting unit adjustments have been completed, repeat steps 4 through 6.

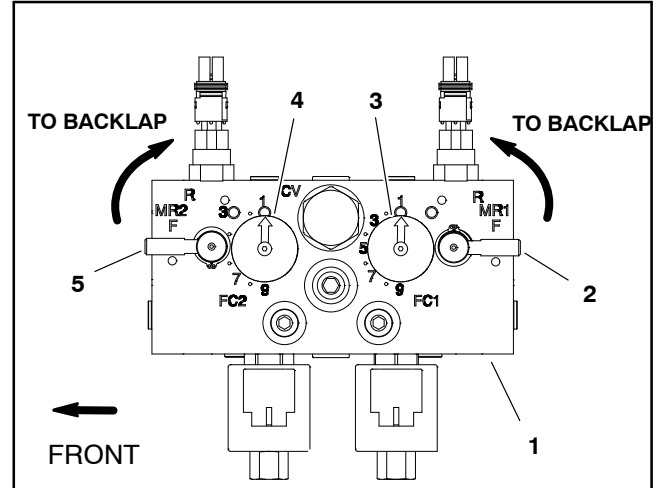

Figure 22

- | | |
|---------------------------|----------------------------|
| 1. Mow control manifold | 4. Front flow control |
| 2. Rear directional lever | 5. Front directional lever |
| 3. Rear flow control | |

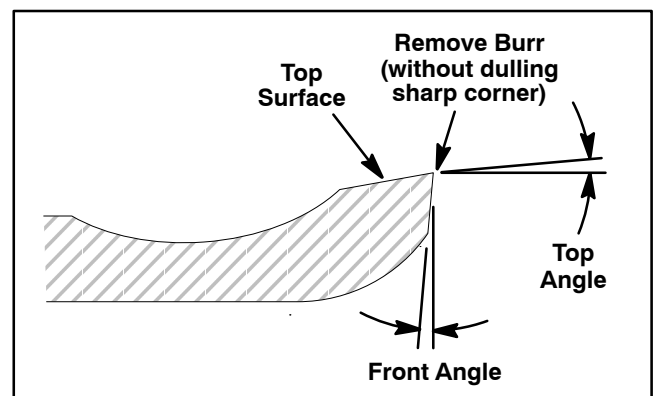

Figure 23

8. When the backlap operation is completed, shut off engine and rotate directional valve lever fully (90° from the backlap position) to the F (forward) position. Also, rotate flow control valve knob to correct mowing position.

9. Wash all lapping compound from the cutting units.

10. For a better cutting edge, run a file across the front face of the bedknife when the lapping operation is completed (Fig. 23). This will remove any burrs or rough edges that may have built up on the cutting edge.

NOTE: Additional instructions and procedures on backlapping are available in the **Toro General Service Training Book, Reel Mower Basics** (part no. 09168SL).

Bedbar Assembly

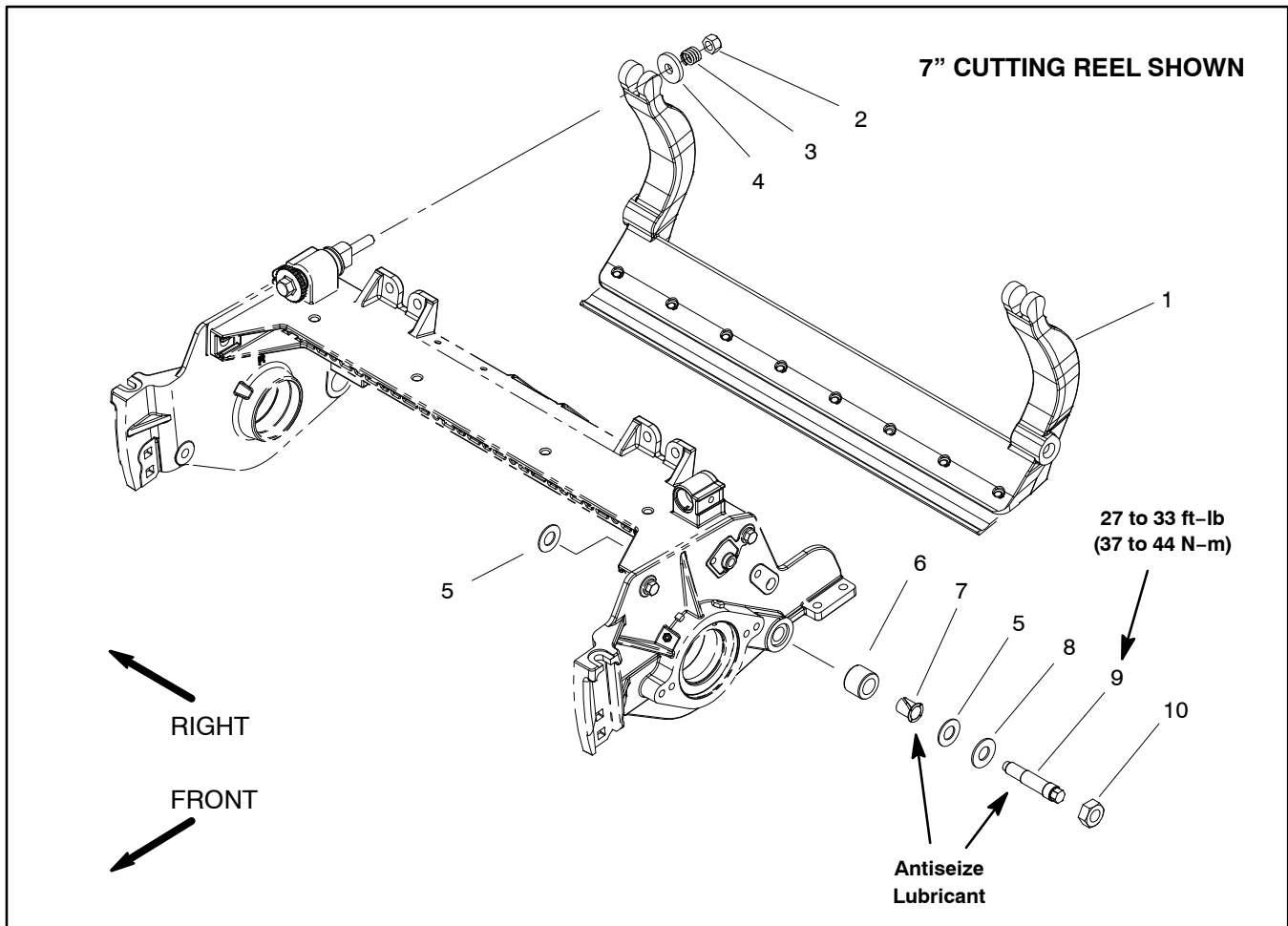

Figure 24

- | | | |
|--------------------------------|----------------------------|-------------------------------|
| 1. Bedbar assembly | 5. Plastic washer (4 used) | 8. Metal washer (2 used) |
| 2. Lock nut (2 used) | 6. Rubber bushing (2 used) | 9. Bedbar pivot bolt (2 used) |
| 3. Compression spring (2 used) | 7. Flange bushing (2 used) | 10. Lock nut (2 used) |
| 4. Washer (2 used) | | |

Bedbar Assembly Removal (Fig. 24)

1. Position machine on a clean and level surface, lower cutting units, stop engine, engage parking brake and remove key from the ignition switch.
2. Remove the cutting unit from the machine. Use the cutting unit kickstand to support the cutting unit (see Special Tools).
3. Loosen the lock nuts (item 2) on the end of each bedbar adjuster assembly until washer (item 2) is loose.
4. Loosen the lock nuts (item 10) on each bedbar pivot bolt.
5. Remove two (2) bedbar pivot bolts (item 9), two (2) metal washers and four (4) plastic washers from the cutting unit side plates.



CAUTION

Contact with the reel, bedknife or other cutting unit parts can result in personal injury. Use heavy gloves when handling the bedbar.

6. Remove bedbar assembly from cutting unit.
7. Inspect flange bushings (item 7) and rubber bushings (item 6) in side plates for wear or damage. Remove bushings and replace if necessary.

DPA Cutting Units

Bedbar Assembly Installation (Fig. 24)

1. If rubber bushing was removed from either cutting unit side plate, install a new bushing. The bushing should be installed flush with the inside of the side plate (Fig. 25).
2. If removed, install the flange bushings with flange facing outward. Apply antiseize lubricant to inside of flange bushing.
3. Apply antiseize lubricant to the bedbar threads and the shoulder area of each bedbar pivot bolt.
4. Slide one metal washer and one plastic washer onto each bedbar pivot bolt.



5. Position bedbar into cutting unit. Make sure that the top of each bedbar arm is between washer (item 4) and adjuster screw flange.
6. Position a plastic washer between bedbar and each cutting unit side plate (Fig. 25).
7. Install the bedbar pivot bolt assemblies:

A. Push each bedbar pivot bolt through the side plate and into the bedbar enough to hold the bedbar in position.

IMPORTANT: Do Not use a powered wrench or an impact wrench to install the bedbar pivot bolts.

B. Start threading of one of the pivot bolts into the bedbar and continue until the pivot bolt bottoms out. Repeat for remaining pivot bolt.

C. Make sure that plastic washers are not caught on the threads of the pivot bolts.

D. Tighten each bedbar pivot bolt from **27 to 33 ft-lbs (37 to 44 N-m)**.

8. Tighten both lock nuts (item 10) until outside metal washer just rotates. Do not over tighten the lock nuts as this can distort the side plates and affect reel to bedknife contact, or in the case of cutting units with painted side plates, reel bearing adjustment. The plastic washer between the bedbar and side plate should be loose.

9. Tighten the lock nut (item 2) on each bedbar adjuster assembly until the adjuster spring is fully compressed, then loosen lock nut 1/2 turn.

10. Adjust cutting unit (see Cutting Unit Operator's Manual).

11. Install cutting unit to machine.

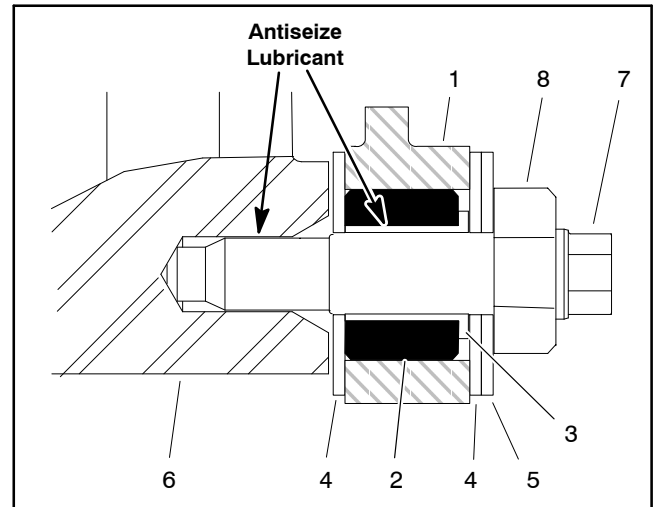

Figure 25

- | | |
|---------------------------|----------------------|
| 1. Cutting unit sideplate | 5. Washer (metal) |
| 2. Rubber bushing | 6. Bedbar |
| 3. Flange bushing | 7. Bedbar pivot bolt |
| 4. Washer (plastic) | 8. Lock nut |

Bedknife Replacement and Grinding

Bedknife Removal

1. Remove bedbar from cutting unit (see Bedbar Assembly in this chapter).
2. Remove screws from bedbar using a socket wrench and bedknife screw tool (see Special Tools in this chapter). Discard screws. Remove bedknife from the bedbar (Fig. 26).
3. See bedknife grinding information on the following pages.

Bedknife Installation

1. Use scraper to remove all rust, scale and corrosion from bedbar surface. Lightly oil bedbar surface before installing bedknife.
2. Make sure that screw threads in bedbar (5/16-18UNC-2A) are clean.

IMPORTANT: Do not use an impact wrench to tighten screws into the bedbar.

3. Use new screws to secure bedknife to bedbar. Apply antiseize lubricant to the threads of new screws. Do not apply antiseize lubricant to the taper of the screw heads.
4. Install all screws but do not tighten.
5. Using a torque wrench and bedknife screw tool, tighten the 2 outer screws to **10 in-lb (1 N-m)**.
6. Working from the center of the bedknife toward each end (Fig. 27), tighten screws from **200 to 250 in-lb (23 to 28 N-m)**.
7. After installing bedknife to bedbar, grind bedknife.

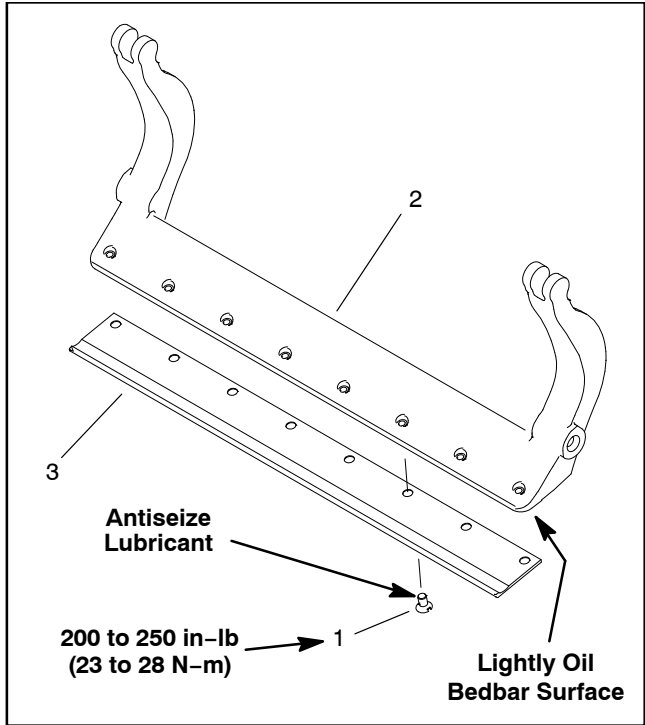

Figure 26

1. Screw (8 used)
2. Bedbar
3. Bedknife

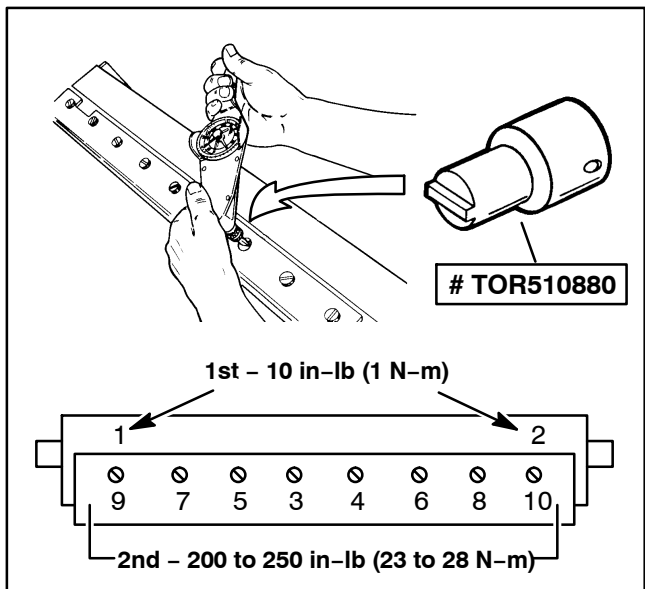

Figure 27

Bedknife Grinding

Since there can be variations in the mounting surface of the bedbar, it is necessary to grind the bedknife after installing it to the bedbar. Follow the bedknife grinding specifications provided and grind only enough to make sure the top surface of the bedknife is true (Fig. 28 and 29).

IMPORTANT: Do Not grind the bedknife below its service limit (Fig. 30). Operating the cutting unit with the bedknife below the service limit may result in poor after-cut appearance and reduce the structural integrity of the bedknife for impacts.

When grinding the bedknife, be careful to not overheat the bedknife. Remove small amounts of material with each pass of the grinder. **Also, clean and dress grinding stone often during the grinding process.**

NOTE: EdgeMax[®] bedknives are extremely hard. Using a diamond grinding wheel is recommended to prevent overheating or damaging the bedknife edge while grinding.

Because the top grind angle on bedknives is critical for edge retention, and therefore after-cut appearance, Toro has developed special service tools for accurately measuring the top grind angle on all bedknives; refer to the Angle Indicator and Magnetic Mount in the Special Tools section of this Chapter.

NOTE: Some bedknives were produced with a 5° top angle. Use a 10° top angle when regrinding all bedknives.

Bedknife Grinding Specifications			
Bedknife	Lip Height Service Limit	Top Angle	Front Angle
EdgeMax Low HOC	0.19" (4.8 mm)	10°	5°
Premium Low HOC			
Standard Low HOC			
Extended EdgeMax Low HOC			10°
Extended Low HOC			
EdgeMax Standard HOC			5°
Standard Standard HOC			
Heavy Duty Standard HOC			

Figure 28

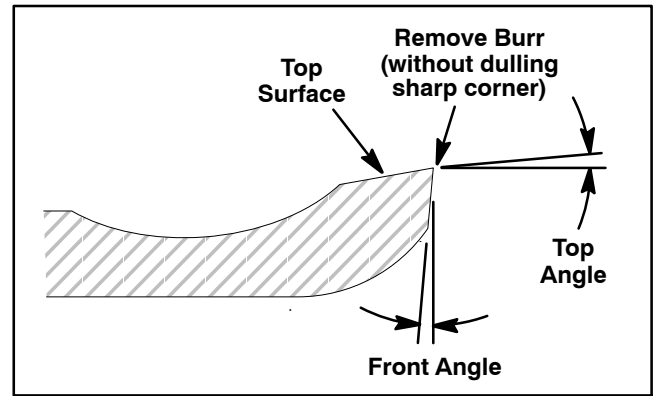

Figure 29

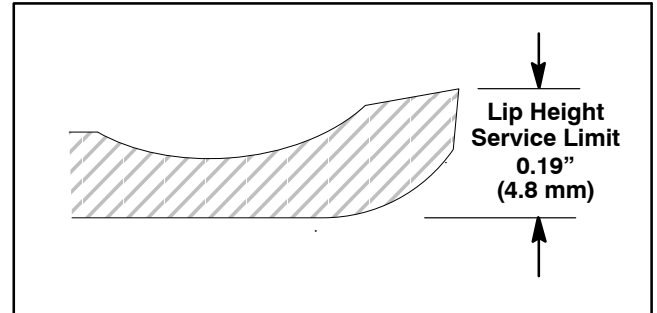

Figure 30

1. Bedknife

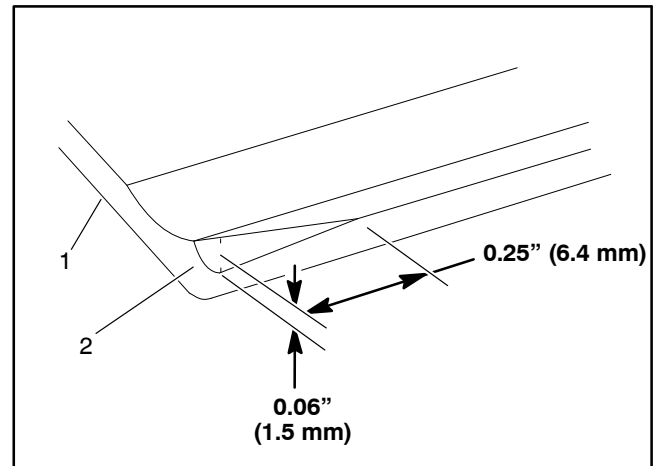

Figure 31

1. Bedknife

2. Lead-in Chamfer

1. Use Toro General Service Training Book, Reel Mower Basics (part no. 09168SL) and grinder manufacturer's instructions for bedknife grinding information.

2. A lead-in chamfer is ground into all new bedknives (Fig. 31). The original chamfer should last for the first 40% of the bedknife service life. Check and re-grind the lead-in chamfer as necessary.

3. After bedknife grinding is complete, install bedbar to cutting unit (see Bedbar Installation in this section).

Bedbar Adjuster Service

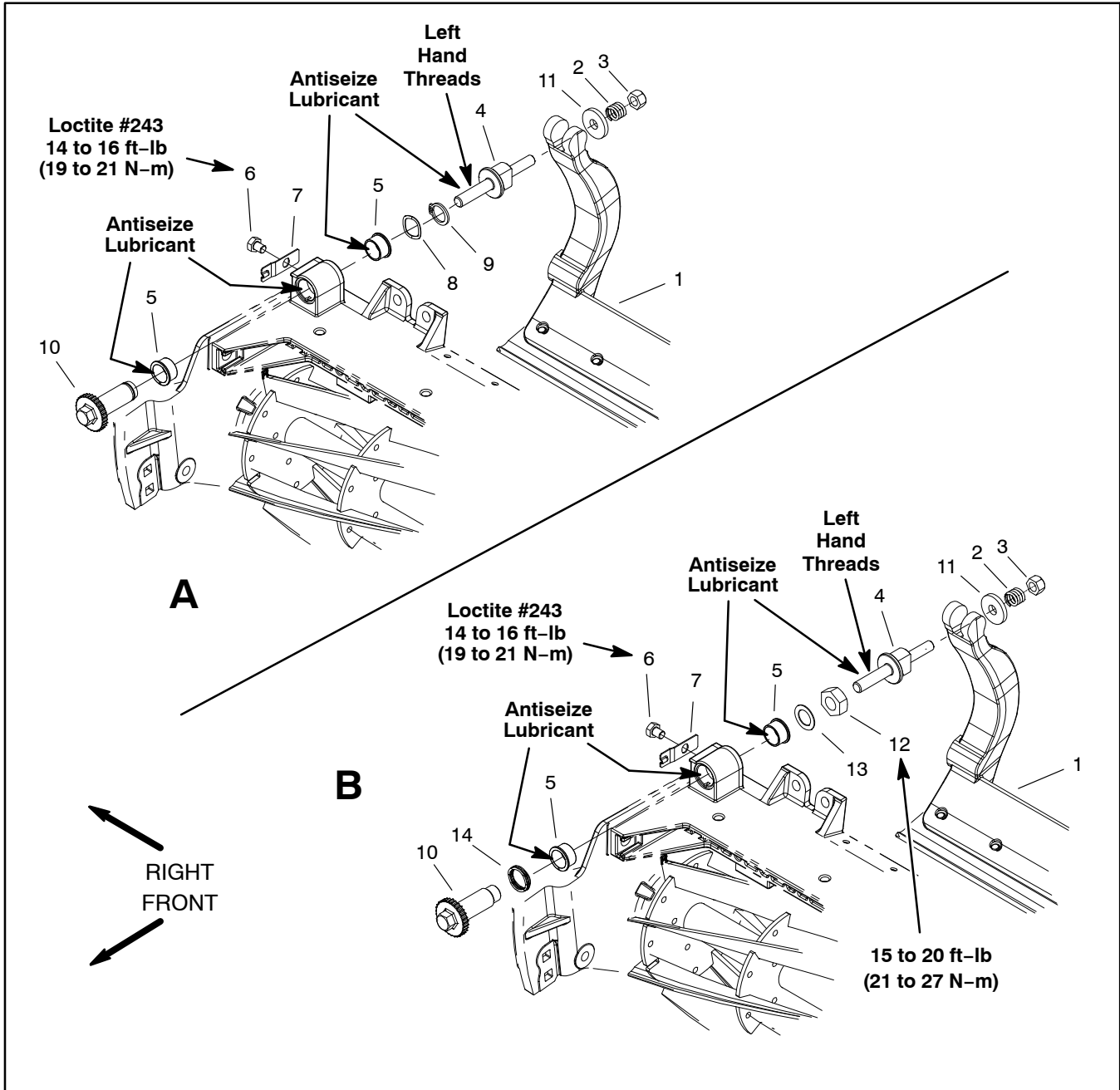

Figure 32

- | | | |
|--------------------------|---------------------------|-----------------|
| 1. Bedbar assembly | 6. Cap screw | 11. Washer |
| 2. Compression spring | 7. Detent | 12. Lock nut |
| 3. Lock nut | 8. Wave washer | 13. Flat washer |
| 4. Bedbar adjuster screw | 9. Retaining ring | 14. Wave washer |
| 5. Flange bushing | 10. Bedbar adjuster shaft | |

NOTE: The bedbar adjuster system for early production DPA cutting units (Fig. 32 A) used a retaining ring on the end of the bedbar adjuster shaft. Current production DPA cutting units (Fig. 32 B) include a lock nut on the end of the bedbar adjuster shaft. Upgrading to the

current production style adjusters is recommended using Heavy Duty DPA Kit p/n 120-7230. The bedbar adjuster service procedures for either style of adjuster shaft is very similar.

Removal (Fig. 32)

1. Remove lock nut (item 3), compression spring and washer from bedbar adjuster screw (item 4).
2. Remove bedbar assembly (see Bedbar Assembly Removal in this section).
3. Remove bedbar adjuster screw (left hand threads) from the bedbar adjuster shaft (item 10).
4. Remove adjuster shaft from cutting unit frame:
 - A. On early production cutting units (Fig. 32 A), remove retaining ring and wave washer from adjuster shaft. Slide adjuster shaft from cutting unit frame.
 - B. On current production cutting units (Fig. 32 B), remove lock nut and flat washer from adjuster shaft. Slide adjuster shaft and wave washer from cutting unit frame.
5. Inspect flange bushings (item 5) in cutting unit frame and remove if necessary.
6. If detent (item 7) is damaged, remove it from cutting unit side plate.

Installation (Fig. 32)

1. If detent (item 7) was removed, apply Loctite #243 (or equivalent) to threads of cap screw and secure detent to cutting unit side plate with cap screw. Tighten cap screw from **14 to 16 ft-lb (19 to 21 N-m)**.

2. If flange bushings (item 5) were removed, apply anti-seize lubricant to bore of cutting unit frame. Align key on bushing to slot in frame and install bushings into frame. Apply anti-seize lubricant to bore of each flange bushing.

3. Install adjuster shaft to cutting unit frame:

- A. On early production cutting units (Fig. 32 A), slide bedbar adjuster shaft into flange bushings in cutting unit frame. Secure adjuster shaft with wave washer and retaining ring.

- B. On current production cutting units (Fig. 32 B), slide wave washer onto adjuster shaft and then slide adjuster shaft into flange bushings in cutting unit frame. Secure adjuster shaft with flat washer and lock nut. Tighten lock nut to shoulder of adjuster shaft and then torque lock nut from **15 to 20 ft-lb (21 to 27 N-m)**.

NOTE: Inside threads in bedbar adjuster shaft (item 4) are left-hand threads.

4. Apply anti-seize lubricant to left hand threads of bedbar adjuster screw (item 4). Thread bedbar adjuster screw into adjuster shaft (item 10).

5. Install washer (item 11), compression spring and lock nut onto adjuster screw.

6. Install bedbar assembly (see Bedbar Assembly Installation in this section).

7. Adjust cutting unit (see Cutting Unit Operator's Manual).

Reel Assembly (cutting units with painted side plates)

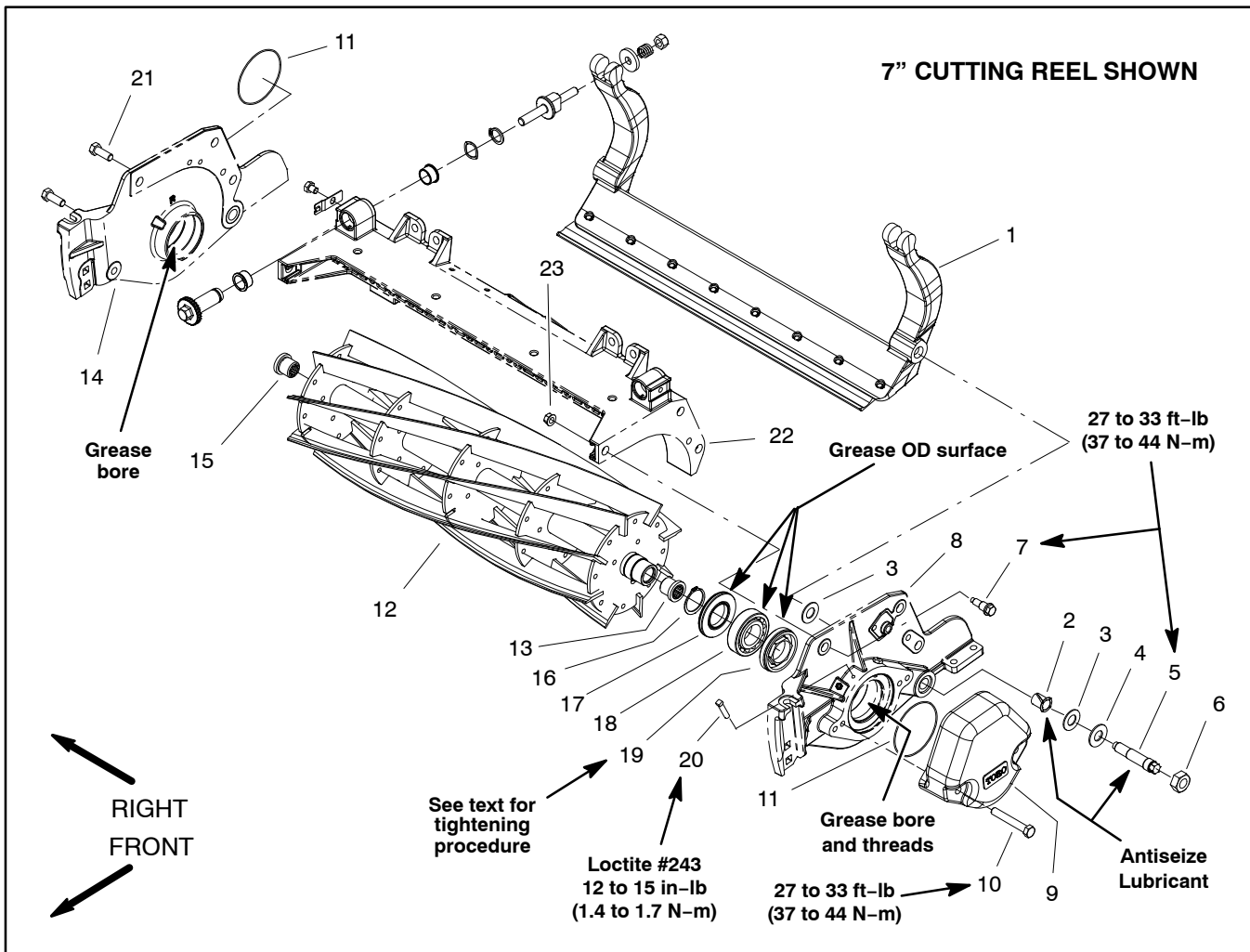

Figure 33

- | | | |
|--|-------------------------------|--|
| 1. Bedbar assembly | 9. Weight | 17. Grease seal (2 used) |
| 2. Flange bushing (2 used) | 10. Cap screw (2 used) | 18. Bearing (2 used) |
| 3. Plastic washer (4 used) | 11. O-ring | 19. Bearing adjuster nut |
| 4. Metal washer (2 used) | 12. Cutting reel | 20. Set screw |
| 5. Bedbar pivot bolt (2 used) | 13. Spline insert (LH thread) | 21. Cap screw (2 used) |
| 6. Lock nut (2 used) | 14. RH side plate | 22. Cutting unit frame |
| 7. Shoulder bolt (3 used per side plate) | 15. Spline insert (RH thread) | 23. Flange nut (3 used per side plate) |
| 8. LH side plate | 16. Retaining ring (2 used) | |

NOTE: This section provides the procedure for removing and installing the cutting reel assembly (cutting reel, spline inserts, grease seals and bearings) from the cutting unit.

NOTE: Refer to Reel Assembly Service later in this section for information on replacing cutting reel grease seals, bearings and spline inserts.

NOTE: Removal of the cutting reel requires removal of the left side plate from the cutting unit frame. The right side plate does not have to be removed from the frame.

Reel Assembly Removal (Fig. 33)

1. Position machine on a clean and level surface, lower cutting units, stop engine, engage parking brake and remove key from the ignition switch.

2. Remove the cutting unit from the machine and place on a flat work area.

3. If the cutting unit is equipped with a counterweight or accessory on LH side plate (as shown in Figure 33), remove the counter weight or accessory. Remove and discard the O-ring from counter weight.

4. If cutting unit is equipped with an optional groomer or rear roller brush, remove components for those options from left hand side plate of cutting unit. See Service and Repairs section of Chapter 8 – Belt Driven Groomer for information on groomer. See Rear Roller Brush in the Service and Repairs section of this chapter for information on rear roller brush.

5. Remove the bedbar pivot bolt and washers from the LH side plate.

6. Loosen fasteners that secure front and rear rollers to LH side plate (see Front Roller Removal and Rear Roller Removal in this section).

7. Remove cap screw and flat washer that secure rear grass shield to LH side plate (Fig. 34).

8. Remove flange head screw that secures support tube, frame spacer and carrier frame to LH side plate (Fig. 34).

NOTE: The reel bearings and grease seals are press fit on the cutting reel shaft and should remain on the reel when removing the LH side plate.

NOTE: Side plates on 5" cutting reel attach to cutting unit frame with two (2) shoulder bolts and flange nuts. Side plates on 7" cutting reel use three (3) shoulder bolts and flange nuts.

9. Remove shoulder bolts (item 7) and flange nuts that secure the LH side plate to the cutting unit frame. Remove the LH side plate from the reel shaft, rollers, bedbar assembly and cutting unit frame.

10. Carefully pull the cutting reel with bearings, grease seals and splined inserts from the RH side plate.

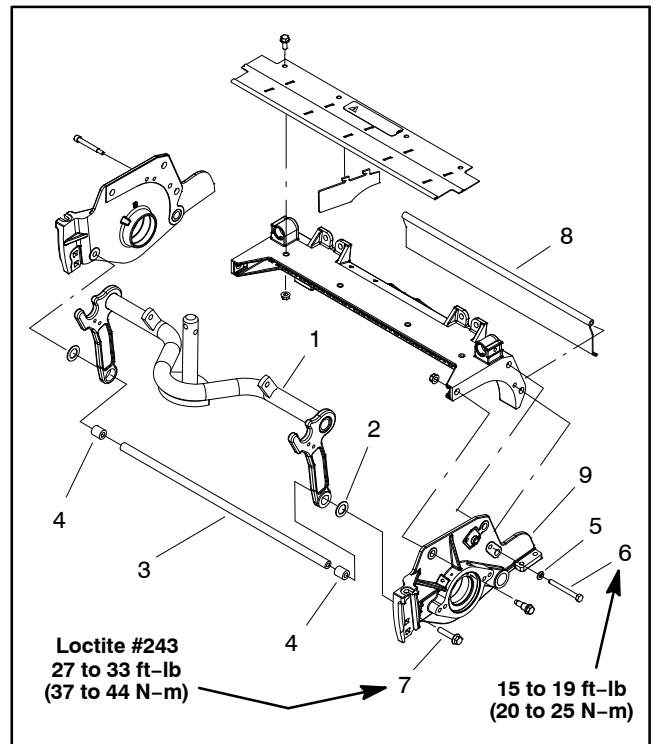

Figure 34

- | | |
|-----------------------|----------------------|
| 1. Carrier frame | 6. Cap screw |
| 2. Shim (if equipped) | 7. Flange head screw |
| 3. Support tube | 8. Rear grass shield |
| 4. Frame spacer | 9. LH side plate |
| 5. Flat washer | |

11. Inspect and service cutting reel assembly as required (see Reel Assembly Service in this section).

Reel Assembly Installation (Fig. 33)

1. Thoroughly clean side plates and other cutting unit components. Inspect side plates for wear or damage and replace if needed.

NOTE: Check that grease seals on cutting reel shaft are flush to 0.060" (1.5 mm) away from retaining ring on reel shaft. If necessary, adjust position of grease seals to allow proper clearance.

2. Make sure that grease seals and bearings are properly greased and positioned on cutting reel (see Reel Assembly Service in this section). Apply thin coat of grease to outside of grease seals and bearings on cutting reel to ease reel installation. Also, apply grease to bearing bores and threads in side plates.



CAUTION

Contact with the reel, bedknife or other cutting unit parts can result in personal injury. Use heavy gloves when removing the cutting reel.



CAUTION

Contact with the reel, bedknife or other cutting unit parts can result in personal injury. Use heavy gloves when installing the cutting reel.

IMPORTANT: During cutting reel installation, keep inner and outer bearing races aligned. If bearing races are not aligned, binding will occur and reel installation may cause bearing damage. Use reel bearing installation tool (Toro part number 117-0975) to help with bearing alignment during reel installation.

3. Using reel bearing installation tool (see Special Tools in this chapter) to keep reel bearing aligned, carefully slide the cutting reel with bearings and grease seals into the RH side plate. Make sure that bearing is fully seated into side plate.

4. On LH side plate, loosen set screw (item 20) and back-off (loosen) bearing adjuster nut one complete turn.

5. Slide the LH side plate onto the cutting reel assembly, front roller and rear roller. Make sure that reel end in RH side plate does not shift in position.

6. Install shoulder bolts (item 7) and flange nuts that secure the LH side plate to the cutting unit frame. Torque the shoulder bolts from **27 to 33 ft-lbs (37 to 44 N-m)**.

7. Apply Loctite #243 (or equivalent) to threads of flange head screw that secures support tube, frame spacer and carrier frame to LH side plate (Fig. 34). Install screw and torque from **27 to 33 ft-lbs (37 to 44 N-m)**. After tightening screw, check the clearance between the carrier frame and side plate. If clearance is more than 0.090" (2.3 mm), remove flange head screw and position shim(s) (part number 67-9410) between carrier frame and side plate so that clearance is less than 0.090" (2.3 mm). Make sure that the carrier frame pivots freely after assembly.

8. Install cap screw and flat washer that secure rear grass shield to LH side plate (Fig. 34). Torque screw from **15 to 19 ft-lbs (20 to 25 N-m)**.

9. Secure the bedbar assembly to LH side plate (see Bedbar Installation in this section).

10. Secure front and rear rollers to LH side plate (see Front Roller Installation and Rear Roller Installation in this section).

IMPORTANT: Over tightening reel bearing adjuster nut may damage reel bearings.

11. Make sure that set screw (item 20) is loose in LH side plate to allow bearing adjuster nut movement. With the cutting unit and reel in a horizontal position, tighten the bearing adjuster nut to **25 in-lb (2.8 N-m)** to remove cutting reel end play.

12. Loosen the bearing adjuster nut. Then torque bearing adjuster nut from **15 to 17 in-lb (1.7 to 1.9 N-m)**. After torquing nut, check that reel rolling torque does not exceed 10 in-lb (1.1 N-m).

13. Apply Loctite #243 (or equivalent) to threads of set screw (item 20) and secure bearing adjuster nut in place with set screw. Torque set screw from **12 to 15 in-lb (1.4 to 1.7 N-m)**.

14. Adjust cutting unit (see Cutting Unit Operator's Manual).

NOTE: The parallel position of the rear roller to the cutting reel is controlled by the precision machined frame and side plates of the cutting unit. If necessary, the cutting unit side plates can be loosened and a slight adjustment can be made to parallel the rear roller with the cutting reel (see Leveling Rear Roller in the Set-Up and Adjustments section of this Chapter).

15. If cutting unit is equipped with optional groomer or rear roller brush, install components for those options to left hand side plate of cutting unit. See Service and Repairs section of Chapter 8 – Belt Driven Groomer for information on groomer. See Rear Roller Brush in the Service and Repairs section of this chapter for information on rear roller brush.

16. If counterweight or accessory was removed from cutting unit, install new O-ring (item 11). Secure counterweight or accessory to cutting unit. Tighten counterweight screws from **27 to 33 ft-lbs (37 to 44 N-m)**.

17. Lubricate cutting unit grease fittings until grease purges from relief valves in side plates. Initial greasing may require several pumps of a hand grease gun.

18. Install cutting unit to the machine.

This page is intentionally blank.

DPA Cutting
Units

Reel Assembly Service (cutting units with painted side plates)

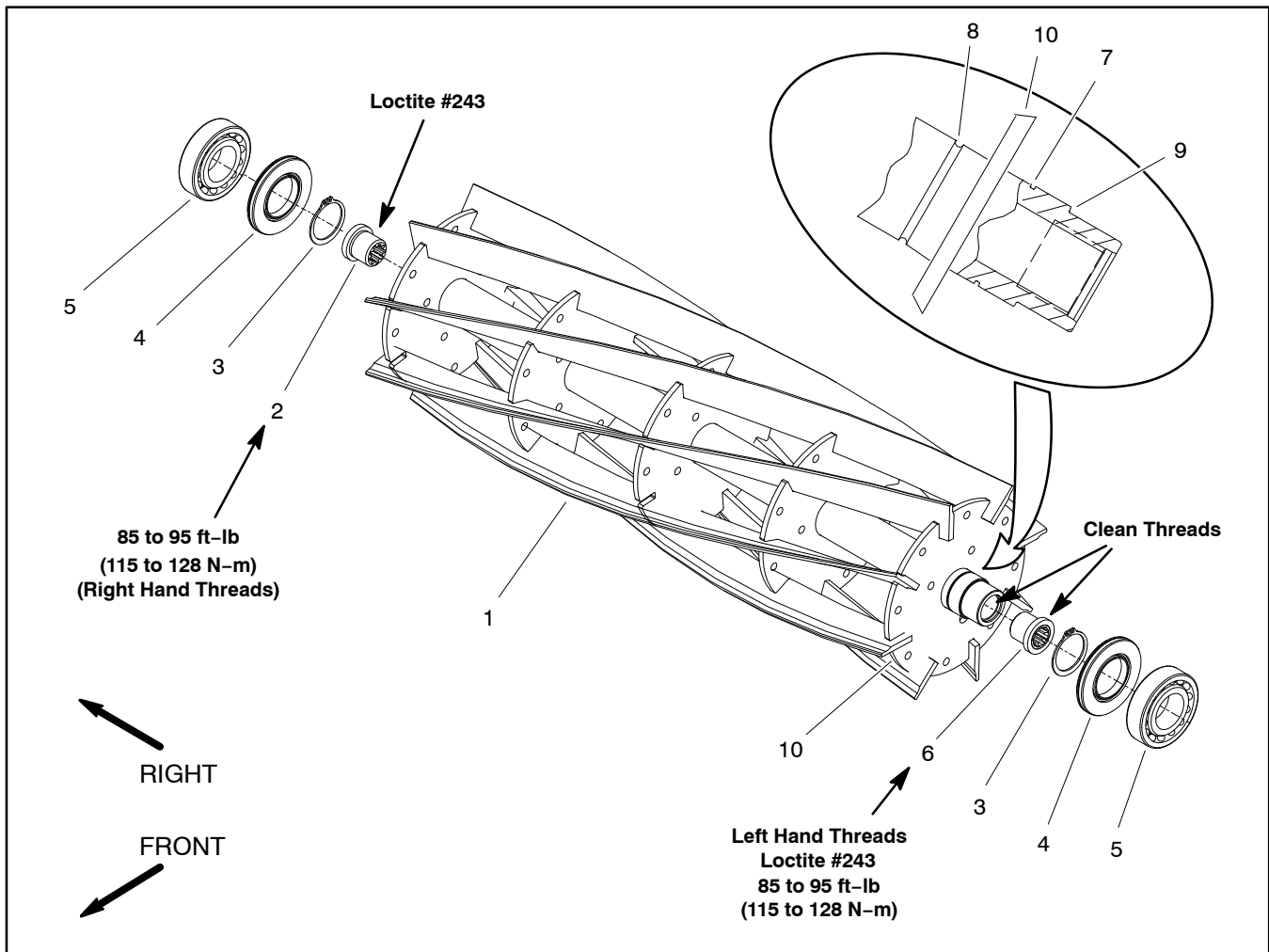

Figure 35

- | | | |
|--------------------------------|--------------------------------|---------------------------------|
| 1. Cutting reel | 5. Bearing | 8. Groove indicating LH threads |
| 2. Threaded insert (RH thread) | 6. Threaded insert (LH thread) | 9. Bearing shoulder |
| 3. Retaining ring | 7. Retaining ring groove | 10. Reel spider |
| 4. Grease seal | | |

Inspection of Cutting Reel (Fig. 35)

1. Inspect reel bearings to insure that they spin freely and have minimal axial play. The bearing balls must be free of deformation and scoring.

2. Inspect the reel shaft as follows. If reel damage is detected, replace reel.

A. Check the reel shaft for bending and distortion by placing the shaft ends in V-blocks.

B. Check the reel blades for bending or cracking.

C. Check the service limit of the reel diameter (see Preparing a Reel for Grinding in this section).

3. Check the threaded inserts in the reel shaft for excessive wear or distortion. Replace inserts if damage is evident.

A. The threaded inserts are installed with thread locking compound (Loctite #243 or equivalent). One insert has LH threads and the other RH threads. The insert with LH threads has an identification groove on the flange face. A groove on the reel shaft identifies the reel end that has LH threads (see illustration in Fig. 35).

B. To remove or install threaded spline inserts, use correct spline insert tool (see Special Tools).

C. To install spline insert into cutting reel, clean threads of insert and cutting reel shaft. Apply Loctite #243 (or equivalent) to threads of insert, thread insert into reel shaft and torque from **85 to 95 ft-lb (115 to 128 N-m)**.

Assembly of Cutting Reel (Fig. 35)

1. If seals and/or bearings were removed from reel shaft, discard removed components and replace.
2. Make sure that the two (2) retaining rings are fully seated into the grooves on the cutting reel shaft.
3. If bearings and seals were removed from reel shaft:
 - A. Make sure that bore of seals are clean with **no** grease or lubricant applied to ID of seal.

IMPORTANT: The grease seal should be installed so the metal side of the seal is toward the bearing location.

B. Press grease seals onto reel shaft with metal side orientated toward bearing location. Final position of seal should be flush to 0.060" (1.5 mm) away from retaining ring on reel shaft. Do not force seal against retaining ring. Seal must be perpendicular to reel shaft after installation.

C. Pack replacement reel bearings with Mobil High Temperature HP grease (or equivalent).

D. Press grease packed bearings fully onto reel shaft. Bearings should bottom on reel shaft shoulder. Press equally on inner and outer bearing race when installing bearings onto reel shaft.

4. Fill threaded insert splines with high temp Mobil XHP-222 grease or equivalent.

Reel Assembly (cutting units with aluminum side plates)

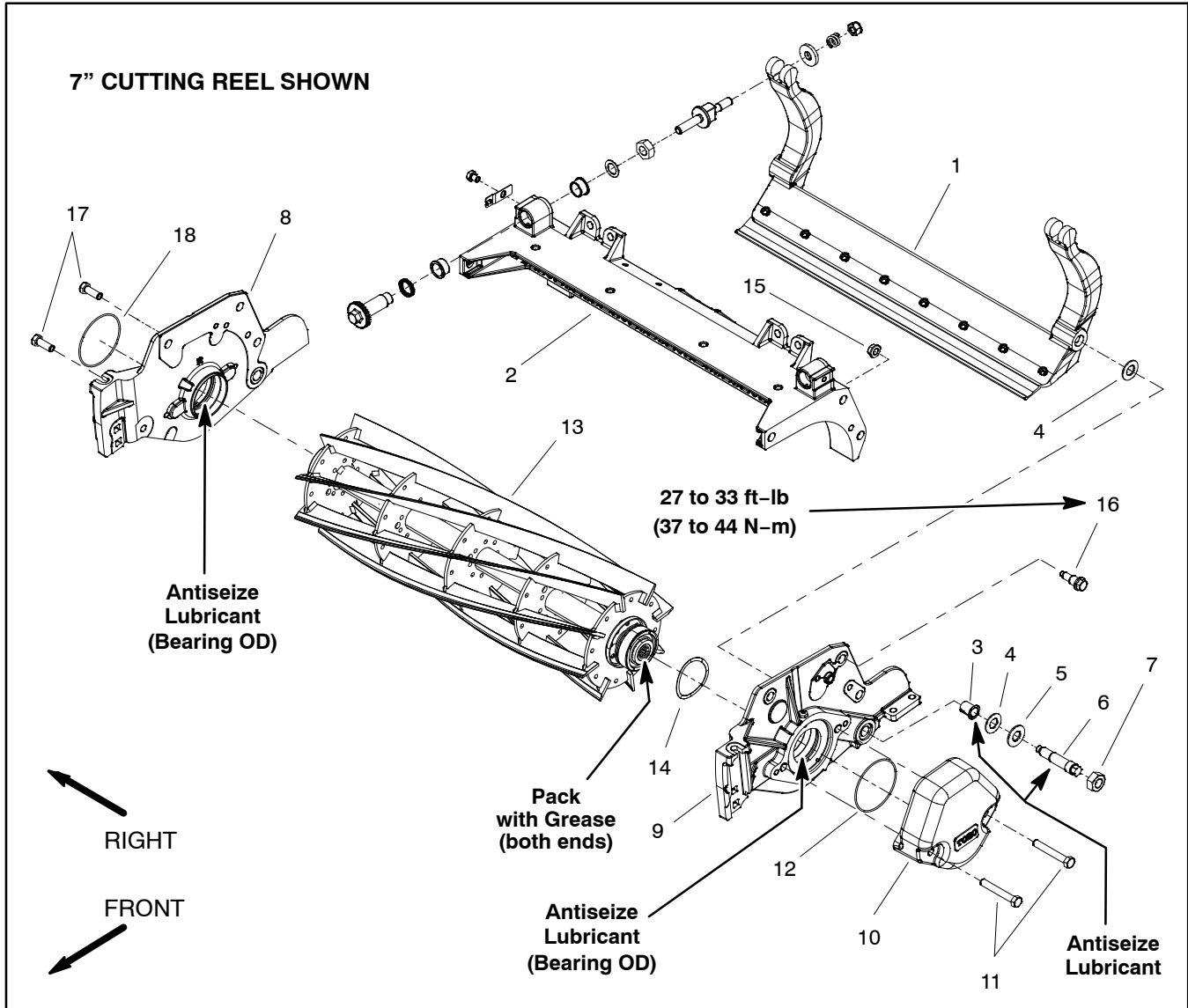

Figure 36

- | | | |
|-------------------------------|------------------------|---|
| 1. Bedbar assembly | 7. Lock nut (2 used) | 13. Cutting reel assembly |
| 2. Cutting unit frame | 8. RH side plate | 14. Wire spring |
| 3. Flange bushing (2 used) | 9. LH side plate | 15. Flange nut (3 used per side plate) |
| 4. Plastic washer (4 used) | 10. Weight | 16. Shoulder bolt (3 used per side plate) |
| 5. Metal washer (2 used) | 11. Cap screw (2 used) | 17. Cap screw (2 used) |
| 6. Bedbar pivot bolt (2 used) | 12. O-ring | 18. O-ring |

NOTE: Refer to Reel Assembly Service later in this section for information on replacing cutting reel seals and bearings.

NOTE: Removal of the cutting reel requires removal of the left side plate from the cutting unit frame. The right side plate does not have to be removed from the frame.

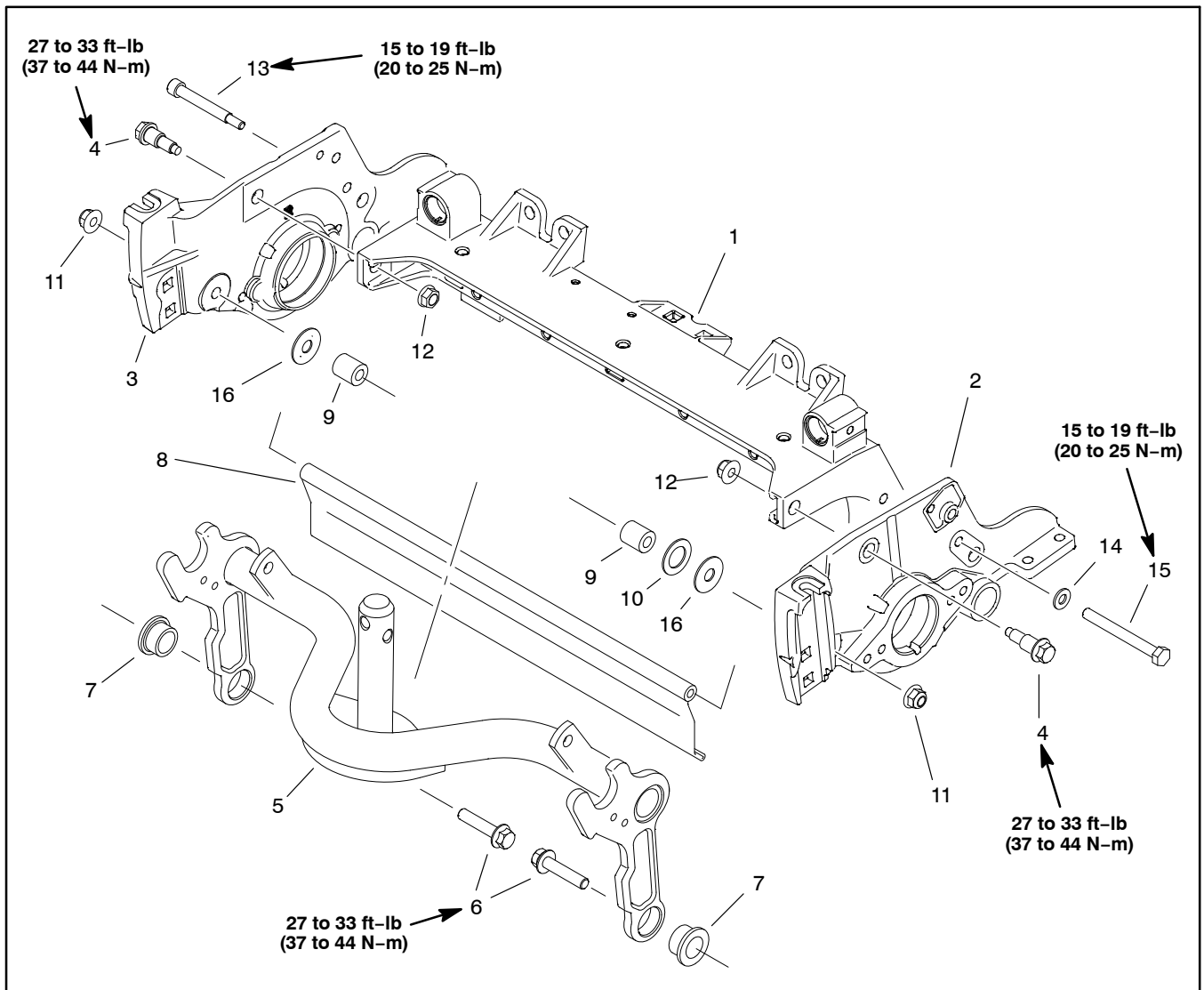

Figure 37

- | | | |
|--------------------------|---------------------------------|------------------------|
| 1. Frame | 7. Flange bushing (2) | 12. Flange nut (4) |
| 2. LH side plate | 8. Rear grass shield | 13. Special screw |
| 3. RH side plate | 9. Spacer (2) | 14. Flat washer |
| 4. Shoulder bolt (4) | 10. Shim (0.060" – as required) | 15. Cap screw |
| 5. Carrier frame | 11. Flange nut (2) | 16. Shim (as required) |
| 6. Flange head screw (2) | | |

Reel Assembly Removal

1. Position machine on a clean and level surface, lower cutting units, stop engine, engage parking brake and remove key from the ignition switch.
2. Remove the cutting unit from the machine and place on a flat work area.



CAUTION

Contact with the reel, bedknife or other cutting unit parts can result in personal injury. Use heavy gloves when removing the cutting reel.

3. If cutting unit is equipped with a counterweight or accessory on LH side plate, remove the counter weight or accessory from the cutting unit. Remove and discard O-ring from counter weight. See Chapter 8 – Belt Driven Groomer or Chapter 9 – Universal Groomer in this manual for additional Groomer information. See Rear Roller Brush in this chapter for information on rear roller brush.

4. Remove bedbar assembly (see Bedbar Assembly in this chapter).

5. Remove front and rear rollers (see Front Roller Removal and Rear Roller Removal in this chapter).

6. Remove cap screw and flat washer that secure rear grass shield to LH side plate.

7. Remove flange head screw and flange nut that secures frame spacer and carrier frame to LH side plate.

NOTE: The reel bearings and grease seals are press fit on the cutting reel shaft and should remain on the reel when removing the LH side plate.

8. Remove two (2) shoulder bolts and flange nuts that secure the LH side plate to the cutting unit frame. Remove the LH side plate from the reel shaft and cutting unit frame.

9. Carefully pull the cutting reel assembly from the RH side plate.

10. Inspect and service cutting reel assembly as required (see Reel Assembly Service in this chapter).

Reel Assembly Installation

1. Thoroughly clean side plates and other cutting unit components. Inspect side plates for wear or damage and replace if needed.

2. Make sure that grease seals and bearings are properly installed on cutting reel (see Reel Assembly Service in this Chapter).

3. Cutting unit serial nos. 315000001 & Up have O-rings in the reel bearing bore of each side plate. Make sure the O-rings are in good condition and properly installed in the side plates.

4. Apply a thin coat of antiseize lubricant to the reel bearing bore of each side plate (Fig. 38).

**CAUTION**

Contact with the reel, bedknife or other cutting unit parts can result in personal injury. Use heavy gloves when installing the cutting reel.

5. Make sure that flat wire spring (item 14 in Fig. 36) is installed into LH side plate.

6. Carefully slide the RH end of the cutting reel assembly (no groove in reel shaft or on face of threaded insert) into the RH side plate. Make sure that bearing is fully seated into side plate.

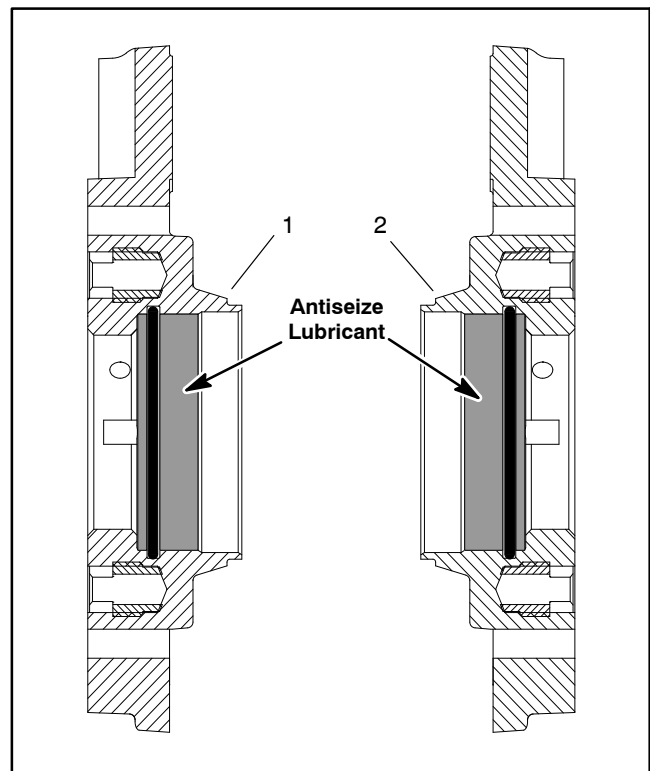

Figure 38

1. Side plate – RH

2. Side plate – LH

7. Slide the LH side plate onto the cutting reel assembly.

8. Install shoulder bolts and flange nuts that secure the LH side plate to the cutting unit frame. Torque the shoulder bolts from **27 to 33 ft-lbs (37 to 44 N-m)**.

9. Apply Loctite #243 (or equivalent) to threads of flange head screw that secures frame spacer and carrier frame to LH side plate. Install screw and torque from **27 to 33 ft-lbs (37 to 44 N-m)**. After tightening screw, check the clearance between the carrier frame and side plate. If clearance is more than **0.065" (1.6 mm)**, remove flange head screw and position shim(s) between carrier frame and side plate so that clearance is less than **0.065" (1.6 mm)**. Make sure that the carrier frame pivots freely after assembly.

10. Install cap screw and flat washer that secure rear grass shield to LH side plate. Torque screw from **15 to 19 ft-lbs (20 to 25 N-m)**.

11. Install the bedbar assembly (see Bedbar Installation in this section).

12. Install front and rear rollers (see Front Roller Installation and Rear Roller Installation in this section).

13. Adjust cutting unit (see Cutting Unit Operator's Manual).

NOTE: The parallel position of the rear roller to the cutting reel is controlled by the precision machined frame and side plates of the cutting unit. If necessary, the cutting unit side plates can be loosened and a slight adjustment can be made to parallel the rear roller with the cutting reel (see Leveling Rear Roller in this Chapter).

14. Install accessories if equipped. See Chapter 8 – Belt Driven Groomer or Chapter 9 – Universal Groomer in this manual for additional Groomer information. See Rear Roller Brush in this chapter for information on rear roller brush.

15. If counterweight was removed from cutting unit, install new O-ring on counter weight. Secure counter weight to cutting unit side plate with two (2) flange nuts. Torque screws from **27 to 33 ft-lbs (37 to 44 N-m)**.

16. Install cutting unit to the machine.

Reel Assembly Service (cutting units with aluminum side plates)

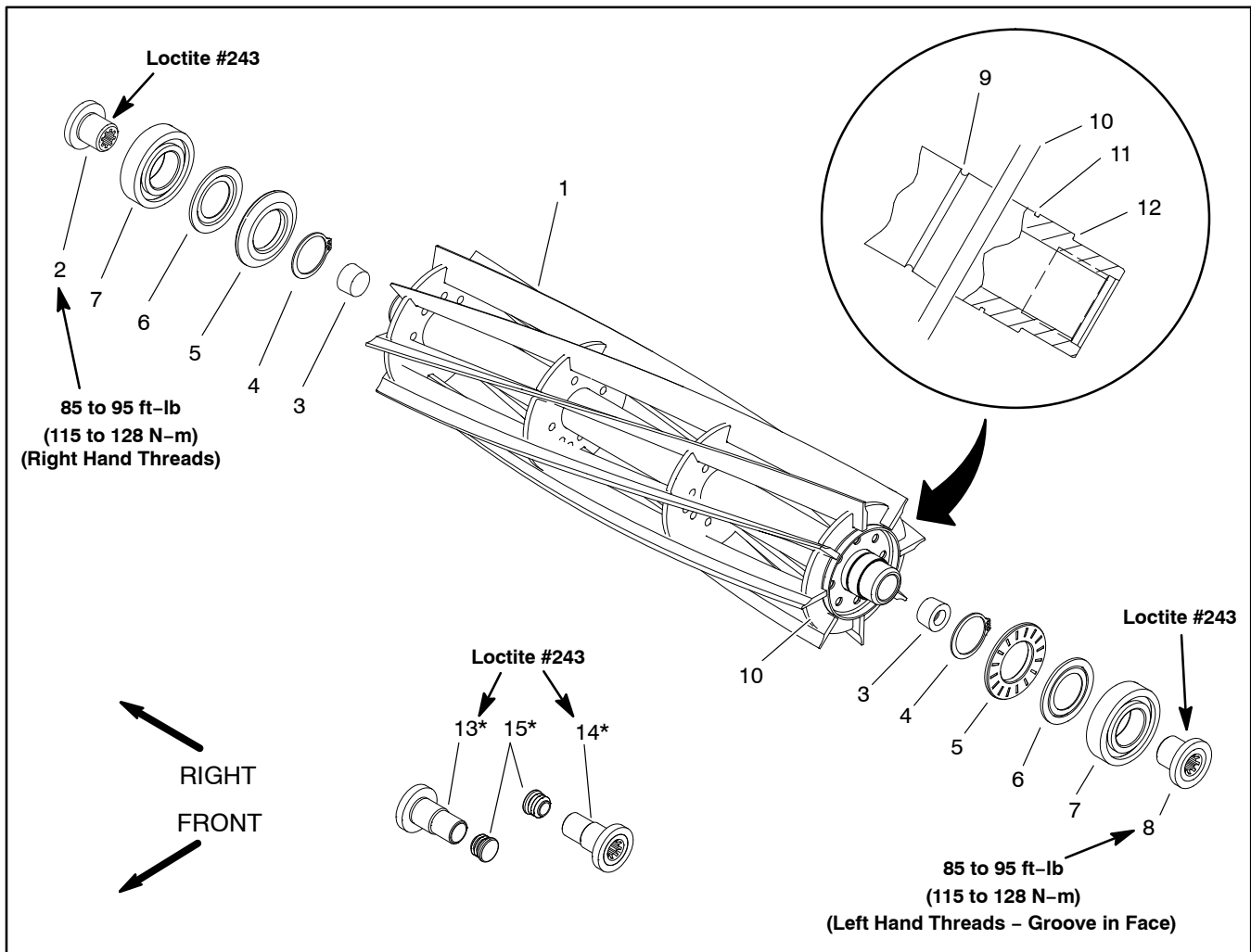

Figure 39

- | | | |
|--------------------------------|---------------------------------|----------------------------------|
| 1. Cutting reel | 6. Flocked seal | 11. Retaining ring groove |
| 2. Threaded insert (RH thread) | 7. Sealed bearing | 12. Bearing shoulder |
| 3. Plastic plug (2) | 8. Threaded insert (LH thread) | 13. Threaded insert (RH thread)* |
| 4. Retaining ring | 9. Groove indicating LH threads | 14. Threaded insert (LH thread)* |
| 5. Special washer | 10. Reel spider | 15. Plastic plug (2)* |

*Used on cutting units prior to serial no. 315000001.

Reel Assembly Inspection

1. Inspect reel bearings to insure that they spin freely and have minimal axial play.
2. Inspect the reel shaft as follows. If reel damage is detected, replace reel.
 - A. Check the reel shaft for bending and distortion by placing the shaft ends in V-blocks.
 - B. Check the reel blades for bending or cracking.
 - C. Check the service limit of the reel diameter (see Preparing a Reel for Grinding in this section).

3. Check the threaded inserts in the reel shaft for excessive wear or distortion. Replace inserts if damage is evident.

A. One insert has LH threads and the other insert has RH threads. The insert with LH threads has a groove on the insert face. A groove is cut in the end of the reel shaft that has LH threads.

B. Use correct spline insert tool to remove threaded inserts (see Special Tools in this chapter).

Reel Assembly

1. If removed, install new reel shaft plugs into cutting reel shaft. For cutting unit serial no. prior to 315000001, make sure plastic plug is pressed flush into end of threaded insert. For cutting unit serial no. 315000001 & Up, make sure plastic plug is pressed unto reel shaft **1.63 to 1.37 in. (41 to 35 mm)** below the end of the shaft (Fig. 40)

NOTE: One insert has LH threads and the other insert has RH threads. The insert with LH threads has a groove on the insert face. A groove is cut in the end of the reel shaft that has LH threads.

2. If previously removed, use correct spline insert tool to install threaded inserts (see Special Tools in this chapter). Apply thread locking compound (Loctite #243 or equivalent) to threaded portion of insert. Tighten threaded insert from **85 to 95 ft-lb (115 to 128 N-m)**.

3. Make sure that the two (2) retaining rings are fully seated into the grooves on the cutting reel shaft.

4. Carefully drive special washers onto reel shaft with tapered side of washers toward reel (flat side toward bearing location). Installed washers should be tight against retaining ring and should not wobble as the reel is rotated.

IMPORTANT: The flocked seal should be installed so the flocked (red) side of the seal is toward the bearing location.

5. Slide flocked seals (flocked (red) side orientated toward bearing location) and bearings fully onto reel shaft. Flocked seals and bearings should bottom on reel shaft shoulder.

6. Fill threaded insert splines with high temp Mobil XHP-222 grease or equivalent.

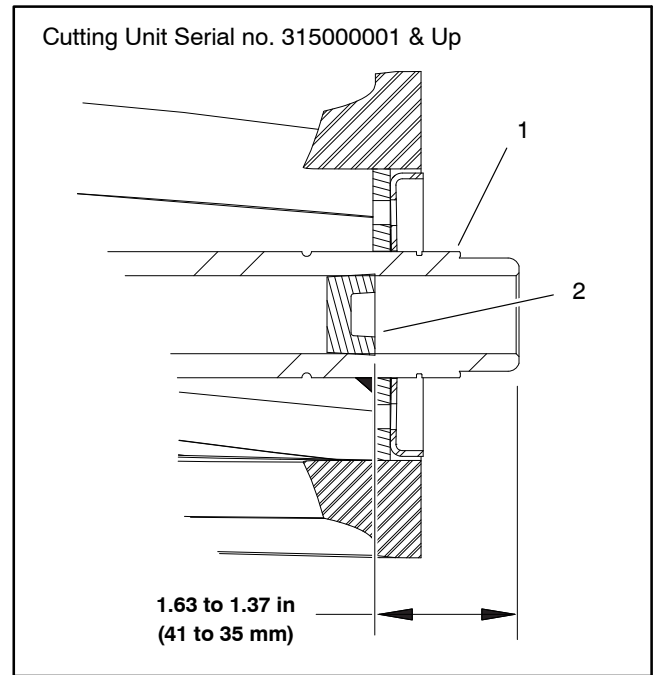

Figure 40

1. Reel shaft

2. Plastic plug (2)

Preparing Reel for Grinding

Three (3) types of reel designs are used in Reelmaster cutting units: scalloped radial reel, tapered radial reel and tapered forward swept reel (Fig. 41). The radial reel designs have blades that are placed in line with the center of the reel shaft. The rear of the blades either have a scalloped relief or a tapered relief. The forward swept reel have blades that have a slight forward slant. The rear of the forward swept reel blades have a tapered relief. Before grinding a reel, identify the type of reel design to make sure that grinding is correctly done.

Before grinding a cutting reel, make sure that all cutting unit components are in good condition. Depending on type of grinder used, faulty cutting unit components can affect grinding results. When grinding, be careful to not overheat the cutting reel blades. Remove small amounts of material with each pass of the grinder.

Follow reel grinder manufacturer's instructions to grind cutting reel to Toro specifications (see Reel Grinding Specifications chart below). Additional reel grinding information can be found in your Cutting Unit Operator's Manual. An additional resource is the Toro Basics Series Training Book, Reel Mower Basics (part no. 09168SL) found on the Service Reference Set available from your Authorized Toro Distributor.

Reel Grinding Specifications		
	5 in. Dia. Reels	7 in. Dia. Reels
Reel Diameter (New)	5.060 in (128.5 mm)	7.060 in (179.3 mm)
Service Limit - Reel Diameter	4.500 in (114 mm)	6.600 in (168 mm)
Reel Shaft Diameter (OD)	1.313 in (33.3 mm)	
Reel Diameter Taper (Fig. 42)	0.001 in (0.025 mm) Service Limit: 0.010 in (0.25 mm)	
Blade Land Width	0.050 to 0.060 in (1.3 to 1.8 mm) Service Limit: .120 in (3.0 mm)	
Blade Relief Angle	30° +/- 5°	

Relief grind the reel blades to the minimum blade land width if the reel blade land width exceeds the service limit. Spin grind the reel to restore its cylindrical shape.

NOTE: Spin grind the reel and establish the specified blade land width after relief grinding.

After grinding the reel and/or bedknife, adjust the cutting unit (see Cutting Unit Operator's Manual). Check the reel to bedknife contact again after cutting two (2) fairways. During this initial use, any burrs will be removed from reel and bedknife which may create improper reel to bedknife clearance and thus accelerate wear. This practice of re-checking the reel to bedknife contact after grinding will extend the longevity of the sharpness of the edge of the reel and the bedknife.

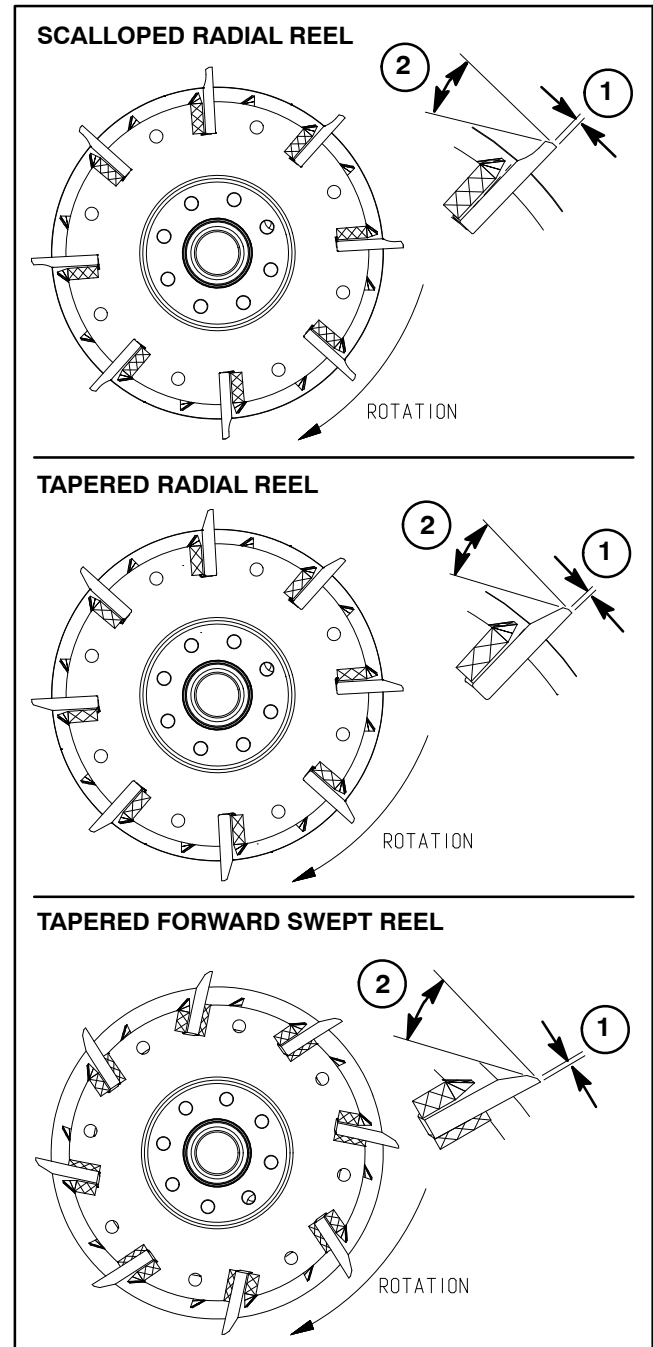

Figure 41

1. Blade land width
2. Blade relief angle

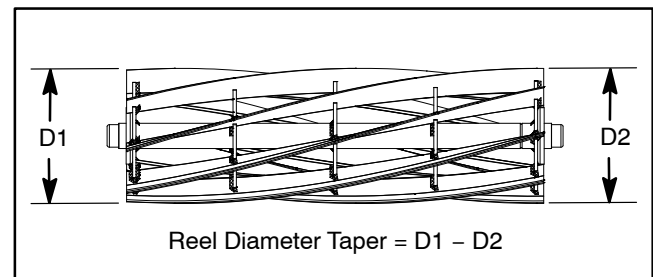

Figure 42

Front Roller

Removal (Fig. 43)

1. Position machine on a clean and level surface, lower cutting units, stop engine, engage parking brake and remove key from the ignition switch.
2. Remove the cutting unit from the machine and place on a level working surface. Use cutting unit kickstand (see Special Tools) to raise front roller from work surface.
3. Loosen flange nut and cap screw securing the front roller shaft to each front height-of-cut (roller) bracket.
4. On one of the height-of-cut (roller) brackets:
 - A. Remove flange lock nut and carriage screw that secure bracket to the cutting unit side plate.
 - B. Remove the height-of-cut (roller) bracket from the cutting unit.
5. Slide the front roller assembly from the remaining height-of-cut (roller) bracket on the cutting unit.
6. If necessary, remove the second height-of-cut (roller) bracket from the cutting unit.

Installation (Fig. 43)

1. Place cutting unit on a level working surface and use cutting unit kickstand (see Special Tools) to support cutting unit.
2. Inspect condition of cap screws (item 1) in both height-of-cut (roller) brackets. Replace cap screw(s) if necessary:
 - A. Place two (2) flat washers on cap screw and thread flange lock nut onto cap screw to a position 0.750" (19 mm) from screw head.
 - B. Apply antiseize lubricant to cap screw threads that will extend into height-of-cut (roller) bracket.
 - C. Thread cap screw into bracket.

NOTE: When assembling height-of-cut (roller) brackets to side plate, make sure that cap screw head and one washer are above adjustment flange on side plate and second washer and flange lock nut are below flange.

3. If both front height-of-cut (roller) brackets were removed from cutting unit side plate, position one of the brackets to side plate. Secure bracket to side plate with carriage screw and flange lock nut.

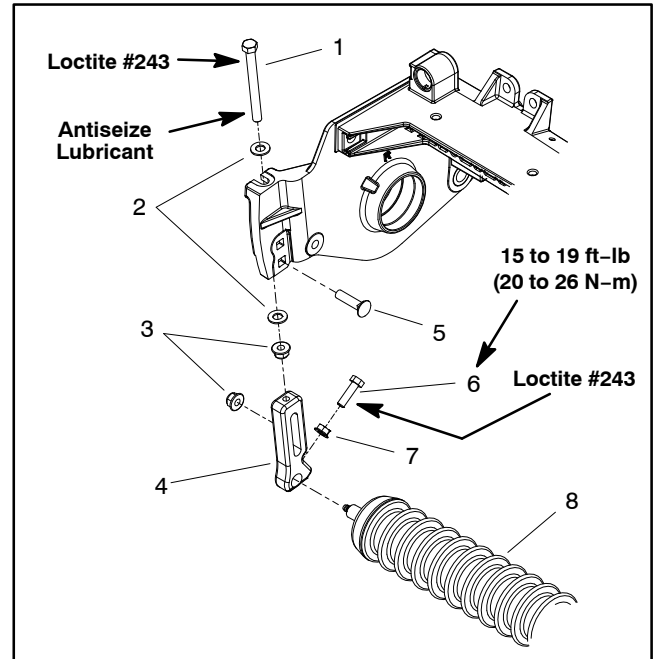

Figure 43

- | | |
|-------------------------|--------------------------|
| 1. Cap screw | 5. Carriage screw |
| 2. Flat washer | 6. Cap screw |
| 3. Flange lock nut | 7. Flange nut |
| 4. HOC (roller) bracket | 8. Front roller assembly |

4. Slide front roller shaft into bracket attached to the cutting unit. Slide second height-of-cut (roller) bracket onto the other end of roller shaft. Secure second bracket to cutting unit side plate with carriage screw and flange nut.

5. Apply Loctite #243 (or equivalent) to exposed threads of cap screw (item 1) between flange of side plate and position of flange lock nut (item 3) on cap screw. Tighten flange lock nut on cap screw and then loosen nut 1/4 to 1/2 turn. Cap screw should rotate freely with little (if any) endplay after lock nut installation.

6. Apply Loctite #243 (or equivalent) to threads of two (2) cap screws (item 6). Center front roller to the cutting reel and secure in place with two (2) cap screws. Torque cap screws from **15 to 19 ft-lb (20 to 26 N-m)**. Secure cap screws with flange nuts.

7. Lubricate front roller.

8. Adjust cutting unit (see Cutting Unit Operator's Manual).

Rear Roller

Removal (Fig. 44)

1. Position machine on a clean and level surface, lower cutting units, stop engine, engage parking brake and remove key from the ignition switch.
2. Remove the cutting unit from the machine and place on a level working surface. Place support blocks under bedbar to raise rear roller from work surface.
3. Loosen two (2) flange nuts that secure the rear roller shaft to each rear roller bracket.
4. On one of the rear roller brackets:

NOTE: On cutting units equipped with optional High Height of Cut Kit, there will be additional roller shims installed between rear roller bracket and cutting unit side plate.

A. Remove flange nuts and carriage screws that secure rear roller bracket and roller shims to the cutting unit side plate.

B. Remove the roller bracket and roller shims from the rear roller and cutting unit.

5. Slide the rear roller assembly from the remaining rear roller bracket on the cutting unit.
6. If necessary, remove the second rear roller bracket and roller shims from the cutting unit.

Installation (Fig. 44)

1. Place cutting unit on a level working surface.

NOTE: Refer to Cutting Unit Operator's Manual for number of roller shims required for various height of cut settings.

NOTE: A 0.010" shim (part number 107-4001) is available to allow for leveling of the rear roller (see Leveling Rear Roller in the Set-up and Adjustments section of this chapter). If necessary, this shim would be used on one side of the rear roller and should be installed between the rear roller bracket and roller shim.

2. If both rear roller brackets were removed from cutting unit side plate, position brackets and roller shims to one of the side plates. Install two (2) carriage screws and flange nuts to retain bracket in position. Do not fully tighten flange nuts.

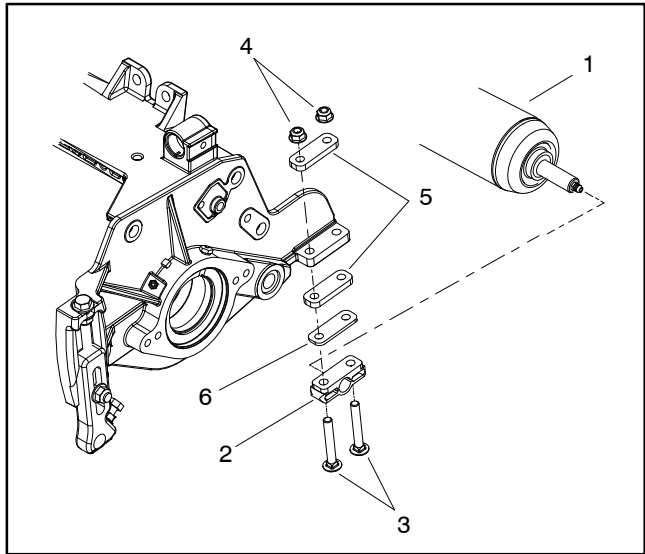

Figure 44

- | | |
|-------------------------|----------------------------|
| 1. Rear roller assembly | 4. Flange nut |
| 2. Rear roller bracket | 5. Roller shim |
| 3. Carriage screw | 6. 0.010" shim (if needed) |

3. Slide rear roller shaft into the rear roller bracket attached to the cutting unit. Slide second rear roller bracket onto the other end of roller shaft. Secure second roller bracket and shims to cutting unit side plate with two (2) carriage screws and flange nuts. Do not fully tighten flange nuts.

4. Center rear roller to the cutting reel and secure in place by tightening four (4) flange nuts.

5. Lubricate rear roller.

6. Adjust cutting unit (see Cutting Unit Operator's Manual).

This page is intentionally blank.

Roller Service (greasable bearings with retaining ring)

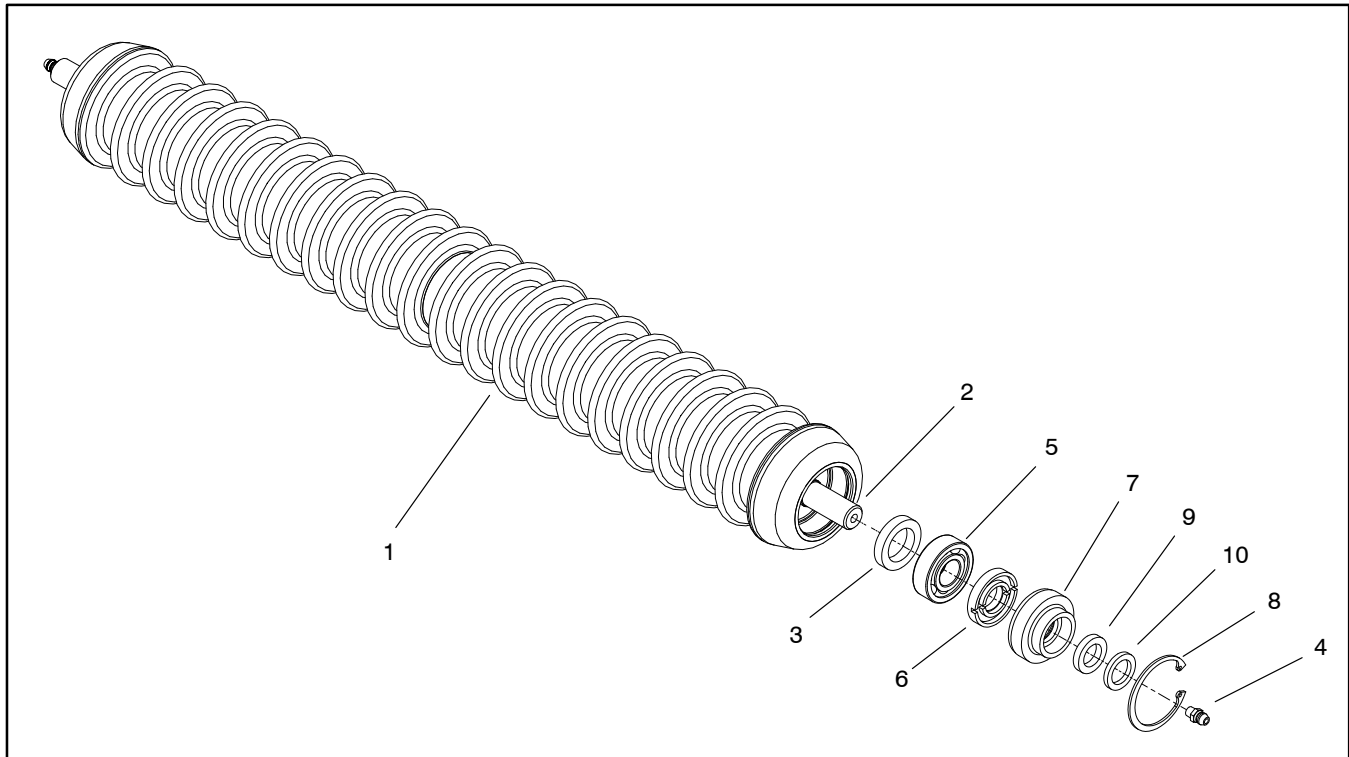

Figure 45

- | | | |
|-------------------------------------|-----------------|-------------------|
| 1. Roller tube (front Wiehle shown) | 5. Ball bearing | 8. Retaining ring |
| 2. Roller shaft | 6. Inner seal | 9. Outer oil seal |
| 3. Inner oil seal | 7. Outer seal | 10. Roller washer |
| 4. Grease fitting | | |

NOTE: Numerous front and rear rollers are available for the Reelmaster cutting units. These rollers use one of two styles of bearing and seal configurations. The first design has retaining rings that secure the bearings and seals in the roller (Fig. 45). The second design uses a bearing lock nut to retain bearings and seals (Fig. 47).

Disassembly (Figs. 45 and 46)

1. Remove retaining ring from both ends of roller.
2. Support roller assembly and press one end of roller shaft to remove seals and bearing from opposite end of roller. Press on other end of roller shaft to remove remaining seals and bearing from roller. Be careful not to drop roller shaft or tube when removing seals and bearings.
3. Discard removed seals and bearings.

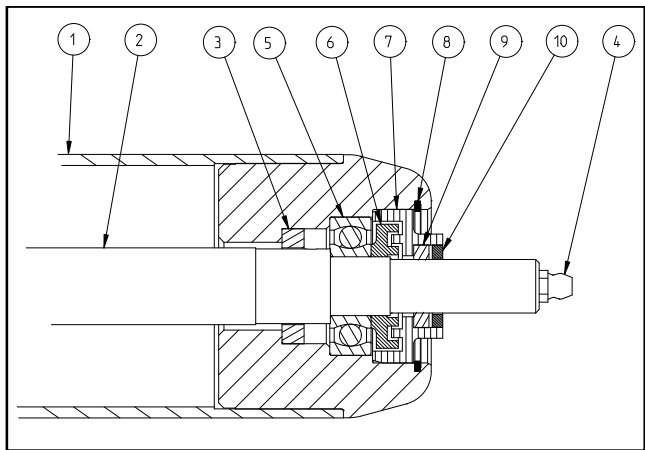

Figure 46

- | | |
|-------------------|-------------------|
| 1. Roller tube | 6. Inner seal |
| 2. Roller shaft | 7. Outer seal |
| 3. Inner oil seal | 8. Retaining ring |
| 4. Grease fitting | 9. Outer oil seal |
| 5. Ball bearing | 10. Roller washer |

Assembly (Figs. 45 and 46)

NOTE: Use of a press is recommended to assemble the roller. If a press is not available, a soft face hammer can be used with the special tools to assemble the roller.

1. Use installation tool TOR4065 and handle TOR4073 to install inner oil seal into each end of roller tube. Apply grease to ID of seal after installation.
2. Install bearings into roller tube:
 - A. Use tool TOR4066 and handle TOR4073 to install bearing into one end of roller.
 - B. Install roller shaft from opposite end of roller. Be careful not to damage the inner oil seals when installing shaft.
 - C. Put roller in a vertical position and support shaft and installed bearing with tool TOR4067.
 - D. Use tool TOR4067 to install second bearing.
3. Use tool TOR4068 to install inner seal.
4. Use tool TOR4069 to install outer seal.
5. Install retaining ring.
6. Use tool TOR4071 to install outer oil seal.
7. Use tool TOR4067 to install roller washer.
8. Put opposite end of roller facing up and support bottom end with tool TOR4067. Repeat steps 3 through 7.
9. Use a hand operated grease gun and No. 2 general purpose lithium base grease to lubricate bearings until grease appears at roller washer. Wipe off excess grease.

Roller Service (greasable bearings with bearing nut)

Disassembly (Fig. 47)

1. Remove bearing lock nut from each end of roller shaft.
2. Loosely secure roller assembly in bench vise and lightly tap one end of roller shaft until outer seals and bearing are removed from opposite end of roller tube. Remove second set of outer seals and bearing from roller tube by tapping on opposite end of shaft. Remove shaft from roller tube.
3. Carefully remove inner seal from both ends of roller tube taking care to not damage tube surfaces.
4. Discard removed seals and bearings.
5. Clean roller shaft and all surfaces on the inside of the roller tube. Inspect components for wear or damage. Also, carefully inspect seating surface and threads of bearing lock nuts. Replace all damaged components.

Assembly (Fig. 47)

1. Install inner seals into roller tube making sure that seal lip (and garter spring) faces end of tube. Use inner seal tool (see Special Tools) and soft face hammer to fully seat seals against roller shoulder (Fig. 48). Apply a small amount of grease around the lip of both inner seals after installation.

IMPORTANT: During assembly process, frequently check that bearings rotate freely and do not bind. If any binding is detected, consider component removal and reinstallation.

2. Install new bearing and outer seals into one end of roller tube:

A. Position a new bearing into one end of roller tube. Use bearing/outer seal tool (see Special Tools) with a soft face hammer to fully seat bearing against roller shoulder (Fig. 49). After bearing installation, make sure that it rotates freely with no binding.

B. Apply a small amount of grease around the lip of both outer seals.

C. Install first outer seal into roller tube making sure that seal lip (and garter spring) faces end of tube. Use bearing/outer seal tool (see Special Tools) and soft face hammer to lightly seat seal against roller shoulder (Fig. 50). Make sure that bearing still freely rotates after seal installation.

D. Using the same process, install second outer seal making sure to not crush the installed outer seal. Again, make sure that bearing still freely rotates.

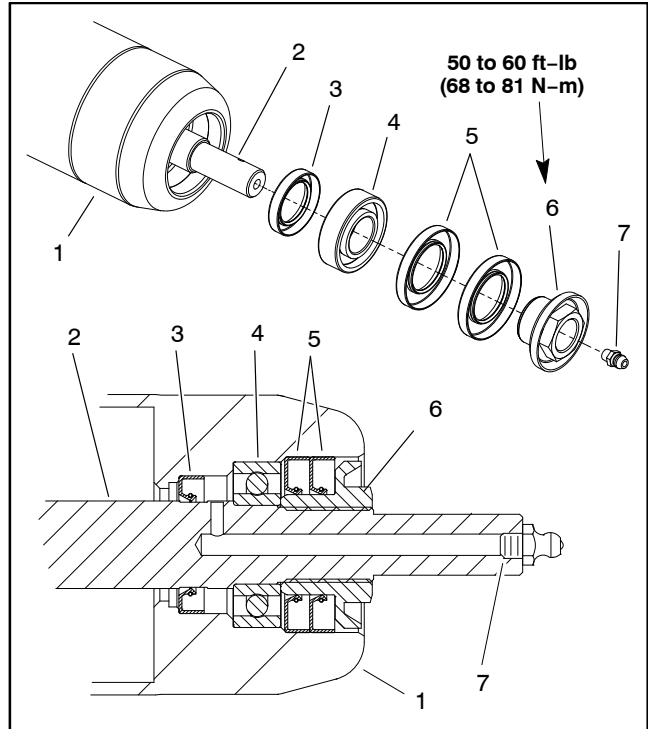

Figure 47

- | | |
|-----------------|---------------------|
| 1. Roller tube | 5. Outer seal |
| 2. Roller shaft | 6. Bearing lock nut |
| 3. Inner seal | 7. Grease fitting |
| 4. Bearing | |

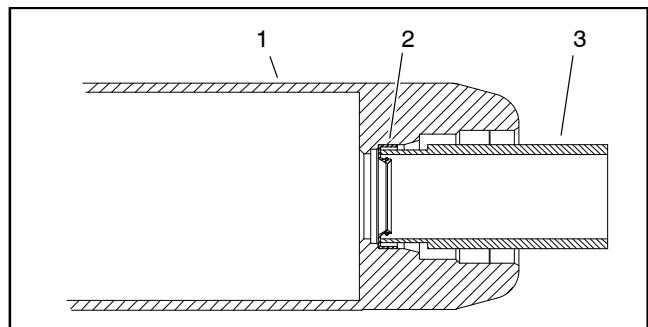

Figure 48

- | | |
|----------------|--------------------|
| 1. Roller tube | 3. Inner seal tool |
| 2. Inner seal | |

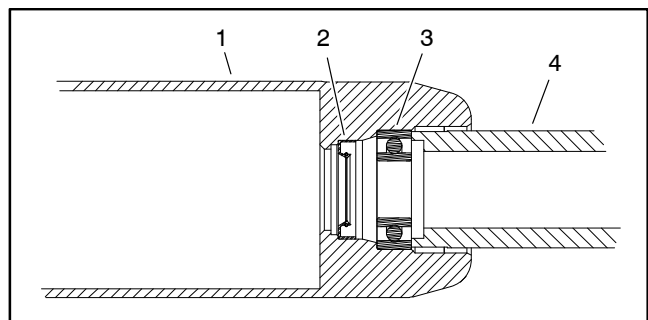

Figure 49

- | | |
|----------------|----------------------------|
| 1. Roller tube | 4. Washer |
| 2. Inner seal | 5. Bearing/outer seal tool |
| 3. Bearing | |

3. From the roller tube end with only the inner seal installed, carefully install the roller shaft into the roller tube. Make sure that seals are not damaged as shaft is installed.

4. Install new bearing and outer seals into second end of roller tube:

A. Position a second new bearing to roller shaft and tube. Position washer (see Special Tools) on bearing to allow pressing on both inner and outer bearing races simultaneously.

B. Use washer and bearing/outer seal tool (see Special Tools) with a soft face hammer to fully seat bearing (Fig. 51). After bearing installation, make sure that shaft freely rotates and that no binding is detected. If necessary, lightly tap bearing and/or shaft ends to align shaft and bearings. Remove washer from roller.

C. Apply a small amount of grease around the lip of both outer seals.

D. Carefully install first outer seal into roller tube making sure that seal lip (and garter spring) faces end of tube. Use bearing/outer seal tool (see Special Tools) and soft face hammer to lightly seat seal (Fig. 52). Make sure that shaft and bearings still freely rotate after seal installation.

E. Using the same process, install second outer seal making sure to not crush the installed outer seal. Again, make sure that shaft and bearings still freely rotate.

IMPORTANT: Make sure that all grease is removed from shaft threads to prevent bearing lock nut loosening.

5. Thoroughly clean threads on both ends of roller shaft.

NOTE: If original bearing lock nut(s) are being used, apply Loctite #243 (or equivalent) to threads of lock nut(s).

6. Install bearing lock nut onto each end of the roller shaft. Make sure that outer seals are not damaged during nut installation. Torque lock nuts from **50 to 60 ft-lb (68 to 81 N-m)**.

IMPORTANT: When roller assembly is installed to cutting deck, make sure that grease groove in each roller mount aligns with the grease hole in each end of roller shaft.

NOTE: After roller is installed to cutting deck, lubricate roller grease fittings, rotate roller to properly distribute grease in bearings and clean excess grease from roller ends. A properly assembled roller should rotate with less than **5 in-lbs (0.68 N-m)** resistance.

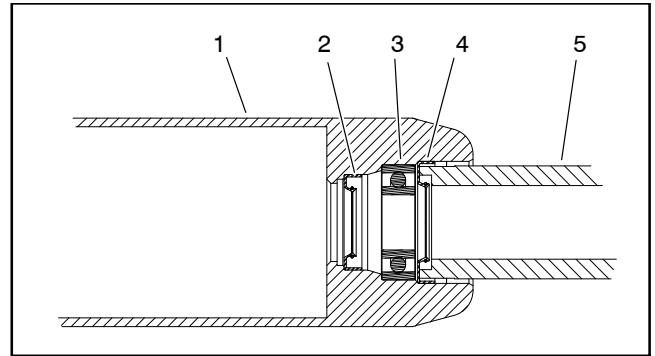

Figure 50

- | | |
|----------------|----------------------------|
| 1. Roller tube | 4. Outer seal |
| 2. Inner seal | 5. Bearing/outer seal tool |
| 3. Bearing | |

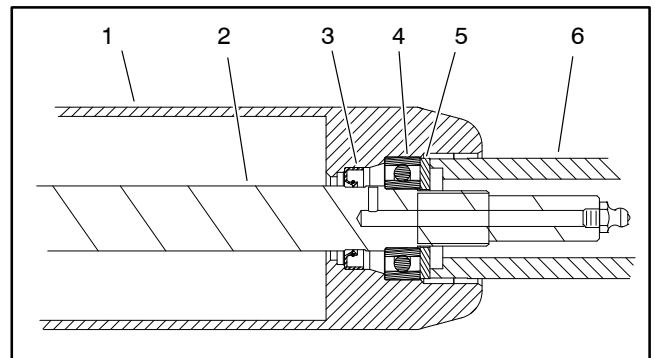

Figure 51

- | | |
|-----------------|----------------------------|
| 1. Roller tube | 4. Bearing |
| 2. Roller shaft | 5. Washer |
| 3. Inner seal | 6. Bearing/outer seal tool |

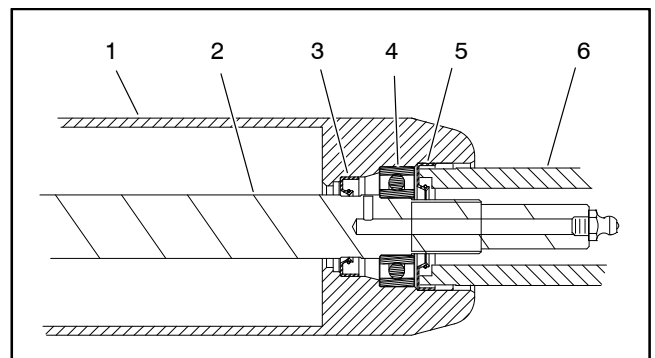

Figure 52

- | | |
|-----------------|----------------------------|
| 1. Roller tube | 4. Bearing |
| 2. Roller shaft | 5. Outer seal |
| 3. Inner seal | 6. Bearing/outer seal tool |

Rear Roller Brush – Optional (cutting units with painted side plates)

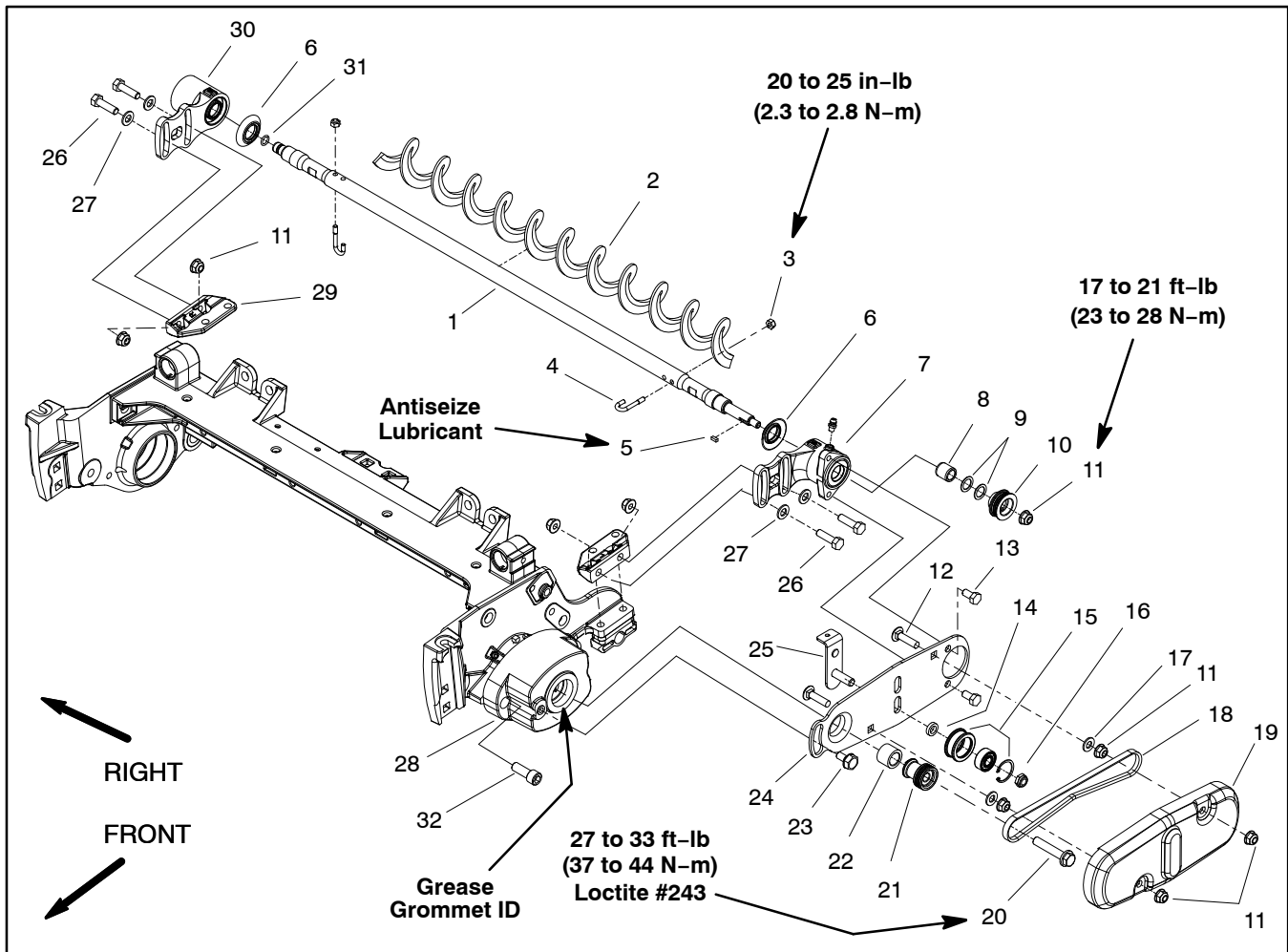

Figure 53

- | | | |
|----------------------------------|-----------------------------|---------------------------------------|
| 1. Roller brush shaft | 12. Carriage screw (2 used) | 23. Shoulder bolt |
| 2. Roller brush | 13. Cap screw (2 used) | 24. Brush plate |
| 3. Lock nut (2 used) | 14. Idler spacer | 25. Idler plate |
| 4. J-bolt (2 used) | 15. Idler pulley assembly | 26. Cap screw (4 used) |
| 5. Square key | 16. Lock nut | 27. Hardened washer (4 used) |
| 6. Excluder seal (2 used) | 17. Flat washer (2 used) | 28. Drive bearing housing |
| 7. Brush bearing housing (drive) | 18. Drive belt | 29. Mounting bracket (2 used) |
| 8. Spacer | 19. Brush cover | 30. Brush bearing housing (non-drive) |
| 9. Flat washer (as required) | 20. Flange head screw | 31. O-ring |
| 10. Driven pulley | 21. Drive pulley | 32. Socket head screw (2 used) |
| 11. Flange nut | 22. Spacer | |

NOTE: Drive components for the rear roller brush are located on the opposite side of the cutting unit from the cutting reel hydraulic motor. Figure 53 shows components used when the brush drive is on the left side of the cutting unit.

NOTE: The Installation Instructions for the rear roller brush kit has detailed information regarding assembly and adjustment. Use those Instructions along with this Service Manual when servicing the rear roller brush.

NOTE: Rear roller brush kits prior to 2008 include an adjustable drive belt idler system as shown in Fig. 53. These kits also use a driven pulley that is located on the brush shaft with a square key. Starting in 2008, brush kits have a sprint-loaded drive belt idler system as shown in Fig. 54. These kits also use a splined driven pulley so no key is necessary.

Disassembly (Fig. 53)

1. Position machine on a clean and level surface, lower cutting units, stop engine, engage parking brake and remove key from the ignition switch.

2. To remove roller brush from brush shaft:

A. Remove the non-drive brush bearing housing (item 30) from cutting unit.

B. Slide excluder seal from roller brush shaft.

C. Remove lock nut and J-bolt from both ends of the brush.

D. While rotating brush, slide brush from the shaft.

3. Disassemble roller brush components as necessary using Figures 53 and 54 as guides.

Assembly (Fig. 53)

1. If brush was removed from shaft, slide brush onto shaft while rotating brush. Secure brush to shaft with two (2) J-bolts and lock nuts. Make sure that the J-bolts are installed with the threaded portion on the outside of the brush (Fig. 55). Torque lock nuts from **20 to 25 in-lb (2.3 to 2.8 N-m)**.

2. If seals or bearings were removed from brush bearing housings, install new components noting proper orientation as shown in Figure 56.

A. Pack bearings with grease before installation.

B. Press bearing into bearing housing so that bearing contacts shoulder in housing bore.

C. Install grease seals so that seal lips are positioned toward the brush location. Press inner seals into housing so that seal contacts bore shoulder. Press outer seals into housing until inner seal is contacted.

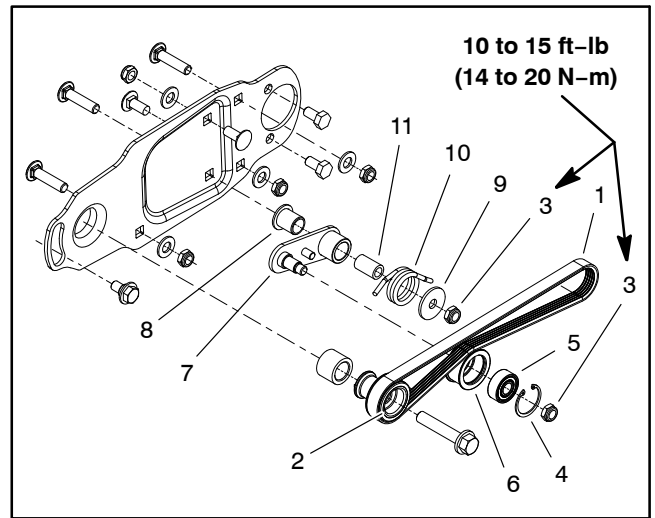

Figure 54

- | | |
|-------------------|-------------------|
| 1. Drive belt | 7. Idler arm |
| 2. Drive pulley | 8. Flange bushing |
| 3. Lock nut | 9. Washer |
| 4. Retaining ring | 10. Idler spring |
| 5. Bearing | 11. Idler spacer |
| 6. Idler pulley | |

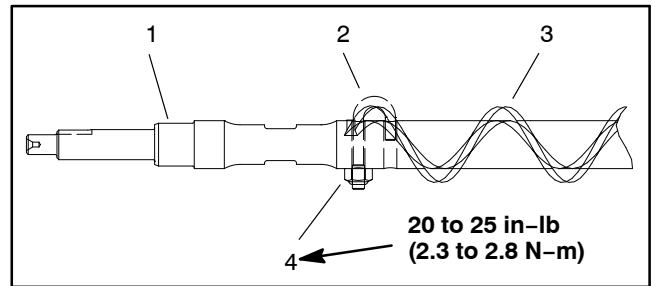

Figure 55

- | | |
|-----------------------|-----------------|
| 1. Roller brush shaft | 3. Roller brush |
| 2. J-bolt | 4. Lock nut |

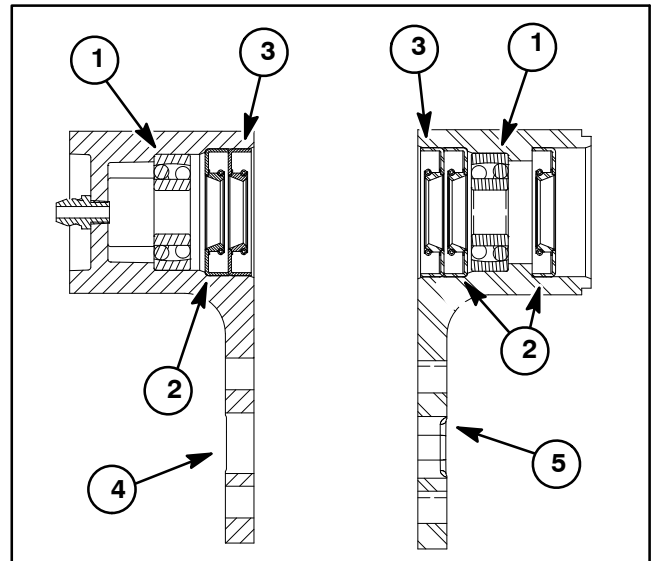

Figure 56

- | | |
|----------------------|-------------------------|
| 1. Bearing | 4. Housing (non-driven) |
| 2. Inner grease seal | 5. Housing (driven) |
| 3. Outer grease seal | |

DPA Cutting Units

3. If drive bearing housing was disassembled, install new components noting proper orientation as shown in Figures 57 and 58.

A. Install bearing on shaft by pressing equally on the inner and outer bearing races. Install the bearing so that the bearing seal is closest to the shoulder on the shaft. Install snap ring onto shaft to retain bearing.

B. Install new grease seal into housing with the lip of the seal toward the drive shaft splines. Apply grease to lip of seal.

C. Fill cavity between bearing location and grease seal 50% to 75% full with high temperature Mobil XHP-222 grease (or equivalent).

D. Carefully slide shaft and bearing fully into pivot hub bore taking care to not damage the grease seal. Secure bearing in pivot hub with retaining ring.

4. Assemble roller brush components using Figures 53 and 54 as guides along with the following:

A. Apply a light coating of grease to inner diameter of the grommet in drive bearing housing.

B. When installing drive pulley (item 21), make sure that tabs on pulley engage slot in drive shaft.

C. Apply antiseize lubricant to square key (if equipped) that locates driven pulley onto roller brush shaft.

D. During assembly, apply Loctite #243 (or equivalent) to threads of fasteners and torque fasteners as shown in Figures 53 and 54.

E. Check alignment of pulleys with a straight edge placed along the outer face of the driven pulley (Fig. 59 or 61). The outer faces of the driven and drive pulleys (not the idler pulley) should be in line within 0.030" (0.76 mm). If necessary to align pulleys, remove driven pulley from brush shaft and add or remove washer(s) (item 9 in Fig. 53) until drive and driven pulleys are aligned.

F. Position excluder seals on brush shaft so that seals just touch bearing housings.

G. After drive belt installation, make sure that the ribs on the belt are properly seated in the grooves of both the drive and driven pulleys and that the belt is in the center of the idler pulley.

H. If roller brush drive includes an adjustable idler pulley (shown in Figure 54), make sure that idler arm (item 7 in Fig. 54) is free to rotate after assembly to brush plate. Also, make sure that idler spring is installed so that it can rotate the idler arm and pulley and apply tension to the drive belt.

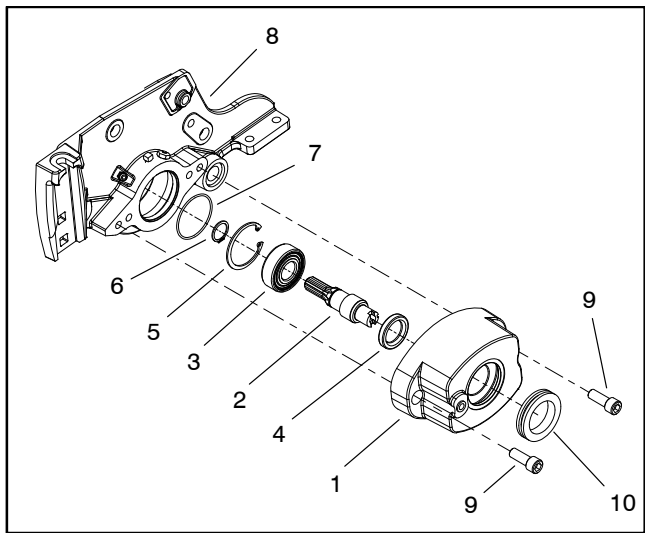

Figure 57

- | | |
|--------------------|----------------------|
| 1. Bearing housing | 6. Snap ring |
| 2. Drive shaft | 7. O-ring |
| 3. Ball bearing | 8. Side plate |
| 4. Grease seal | 9. Socket head screw |
| 5. Retaining ring | 10. Grommet |

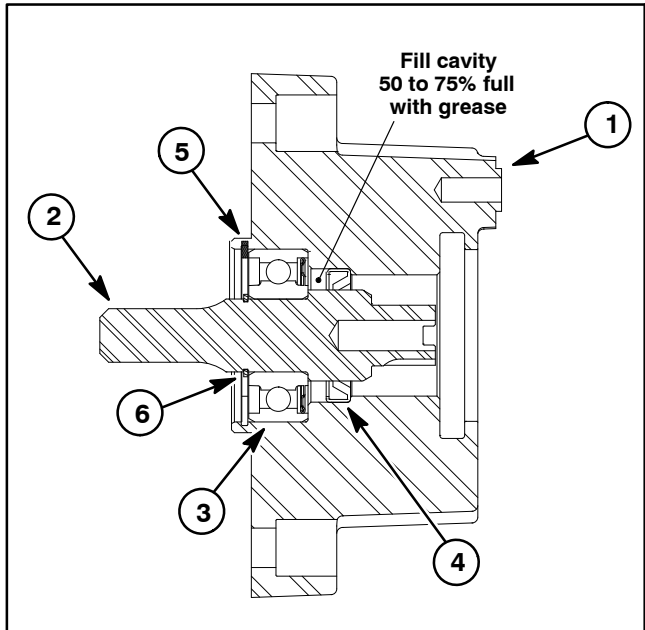

Figure 58

- | | |
|--------------------|-------------------|
| 1. Bearing housing | 4. Grease seal |
| 2. Drive shaft | 5. Retaining ring |
| 3. Ball bearing | 6. Snap ring |

5. To tension a roller brush drive system that includes an adjustable idler pulley (shown in Figure 53), make sure idler pulley lock nut is loose. Lift up on idler plate tab with 15 lbs of force for a new belt (10 lbs of force for a used belt) and tighten pulley lock nut. Refer to decal on brush plate (Fig. 60).

IMPORTANT: The roller brush shaft must not contact the cutting unit side plate. Also, heavy brush contact on the rear roller will cause premature brush wear.

6. Check that brush is parallel to rear roller with 0.060" (1.5 mm) clearance to light contact with rear roller (Fig. 62). If contact is incorrect, brush operation will be adversely affected.

7. Install cover (item 20). There **should not** be a set screw installed in the bottom of the cover.

8. Lubricate grease fittings on brush housings until grease purges past inboard seals. Wipe excess grease from seals and fittings.

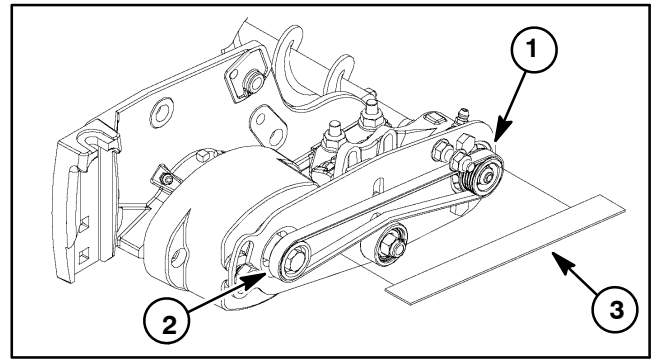

Figure 59

- 1. Driven pulley
- 2. Drive pulley
- 3. Straight edge

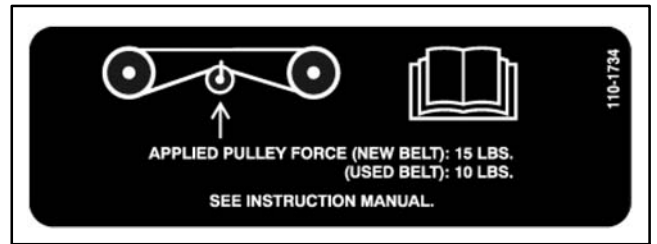

Figure 60

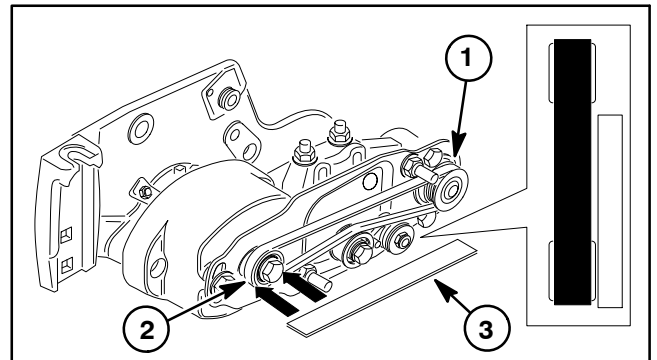

Figure 61

- 1. Driven pulley
- 2. Drive pulley
- 3. Pulley alignment tool

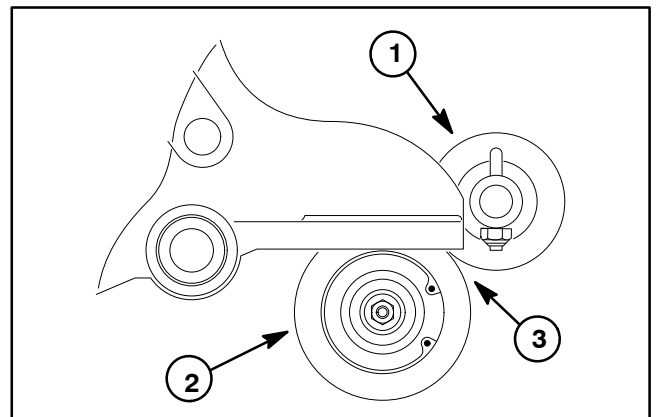

Figure 62

- 1. Rear roller brush
- 2. Rear roller
- 3. Light contact

Rear Roller Brush – Optional (cutting units with aluminum side plates)

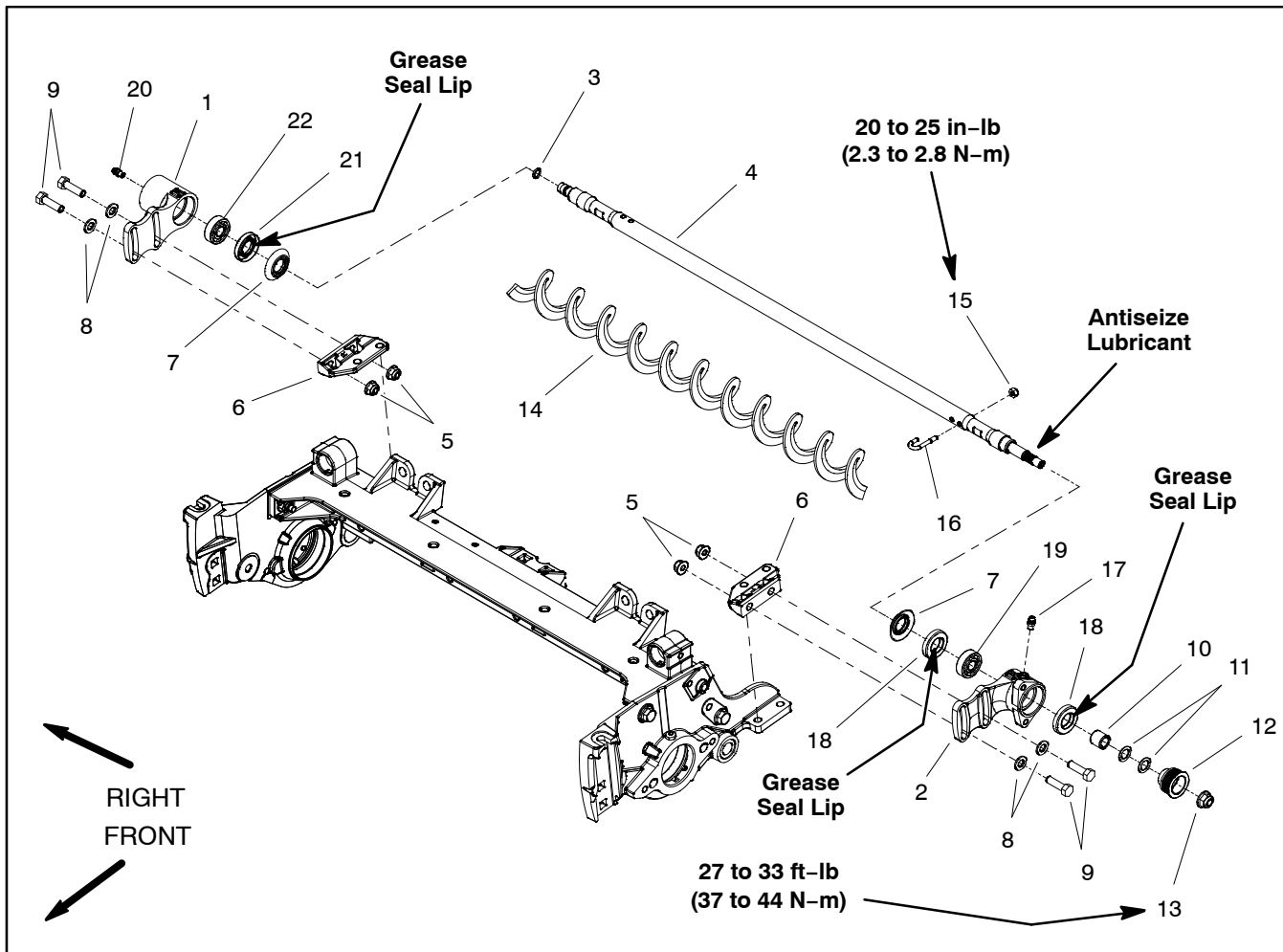

Figure 63

- | | | |
|--------------------------------------|--|---------------------|
| 1. Brush bearing housing (non-drive) | 9. Cap screw (4 used) | 16. J-bolt (2 used) |
| 2. Brush bearing housing (drive) | 10. Spacer | 17. Grease fitting |
| 3. O-ring | 11. Flat washer (for pulley alignment) | 18. Grease seal |
| 4. Roller brush shaft | 12. Driven pulley | 19. Ball bearing |
| 5. Flange nut (4 used) | 13. Flange nut | 20. Grease fitting |
| 6. Mounting bracket (2 used) | 14. Roller brush | 21. Grease seal |
| 7. Excluder seal (2 used) | 15. Lock nut | 22. Ball bearing |
| 8. Flat washer (4 used) | | |

NOTE: Drive components for the rear roller brush are located on the opposite side of the cutting unit from the cutting reel motor. Figure 53 shows components used when the brush drive is on the left side of the cutting unit.

NOTE: The Installation Instructions for the rear roller brush kit has detailed information regarding assembly and adjustment. Use those Instructions along with this Service Manual when servicing the rear roller brush.

Rear Roller Brush Disassembly (Fig. 53)

1. Position machine on a clean and level surface, lower cutting units, stop engine, engage parking brake and remove key from the ignition switch.

2. To remove roller brush from brush shaft:

- A. Remove the non-drive brush bearing housing (item 1) from cutting unit.
- B. Slide excluder seal from roller brush shaft.
- C. Remove lock nut and J-bolt from both ends of the brush.
- D. While rotating brush, slide brush from the shaft.

3. Disassemble roller brush components as necessary using Figures 53 as a guide. If drive brush bearing housing (item 2) or driven pulley (item 12) need to be removed, brush cover and drive belt removal will be necessary (see Rear Roller Brush Drive System in this section).

Rear Roller Brush Assembly (Fig. 53)

1. If seals or bearings were removed from brush bearing housings, install new components noting proper orientation as shown in Figure 56.

A. Pack bearings with high temp Mobil XHP-222 grease (or equivalent) before installation.

B. Press bearing into bearing housing so that bearing contacts shoulder in housing bore.

C. Install grease seals so that seal lips are positioned toward the brush location as shown in Fig. 56. Press seals into housing so that seal contacts bore shoulder.

2. If roller brush was removed from roller shaft, slide brush onto shaft while rotating brush. Secure brush to shaft with two (2) J-bolts and lock nuts. Make sure that the J-bolts are installed with the threaded portion on the outside of the brush (Fig. 55). Torque lock nuts from **20 to 25 in-lb (2.3 to 2.8 N-m)**.

3. Assemble roller brush components using Figure 53 as a guide noting the following items:

A. Apply coating of grease to lips of grease seals in brush bearing housing before inserting brush shaft into housing.

B. If driven pulley (item 12) was removed from roller brush shaft, apply antiseize lubricant to splines of pulley bore and slide pulley onto shaft. Install and tighten flange nut until pulley is seated onto shaft and then torque flange nut from **27 to 33 ft-lb (37 to 44 N-m)**. Use a ½ wrench on roller brush shaft flats to prevent shaft from rotating when tightening nut.

C. Position excluder seals on brush shaft so that seals just touch bearing housings.

D. If driven pulley (item 12) was removed, check and adjust alignment of drive and driven pulleys (see Rear Roller Brush Drive System in this section).

4. Check that brush is parallel to rear roller with 0.060" (1.5 mm) clearance to light contact with rear roller (Fig. 62). If contact is incorrect, brush operation will be adversely affected.

5. Lubricate grease fittings on brush housings until grease purges past inboard seals. Wipe excess grease from seals and fittings.

6. Once all rear roller brush service is completed, plug the 48 VDC battery disconnect back in before operating the machine.

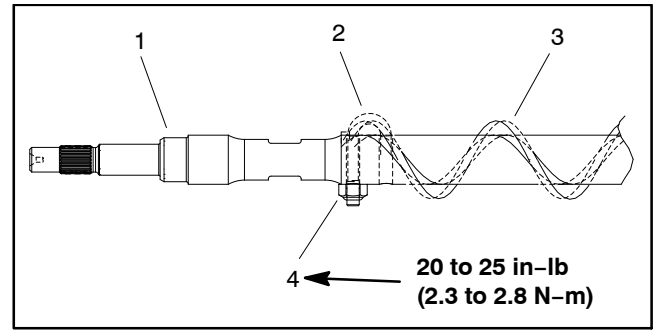

Figure 64

- | | |
|-----------------------|-----------------|
| 1. Roller brush shaft | 3. Roller brush |
| 2. J-bolt | 4. Lock nut |

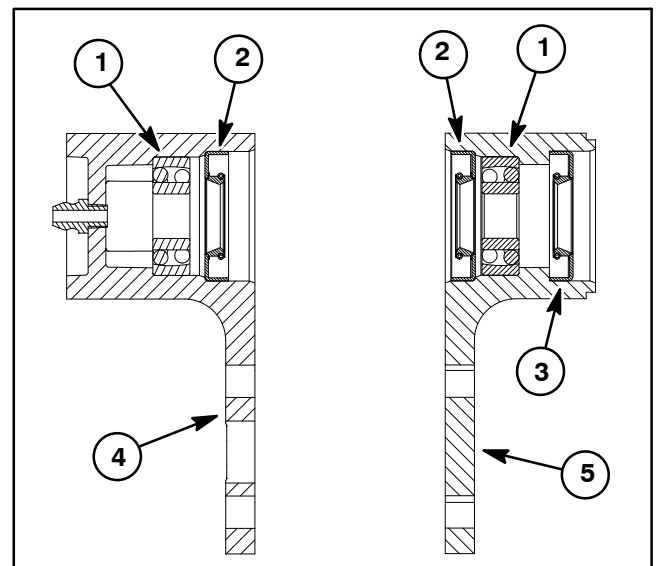

Figure 65

- | | |
|----------------------|-------------------------|
| 1. Bearing | 4. Housing (non-driven) |
| 2. Inner grease seal | 5. Housing (driven) |
| 3. Outer grease seal | |

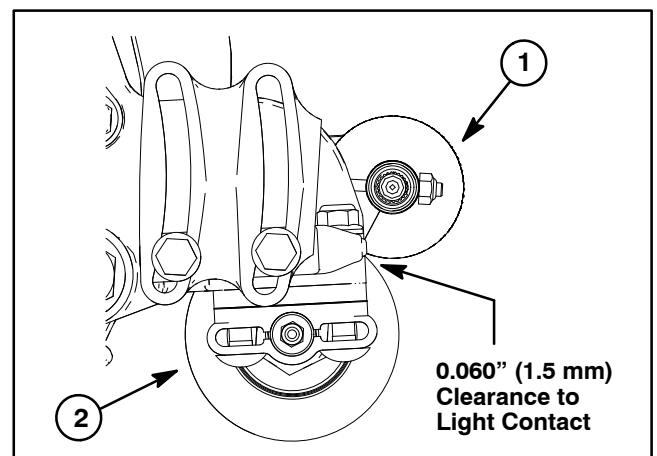

Figure 66

- | | |
|----------------------|----------------|
| 1. Rear roller brush | 2. Rear roller |
|----------------------|----------------|

Drive System Disassembly (Fig. 67)

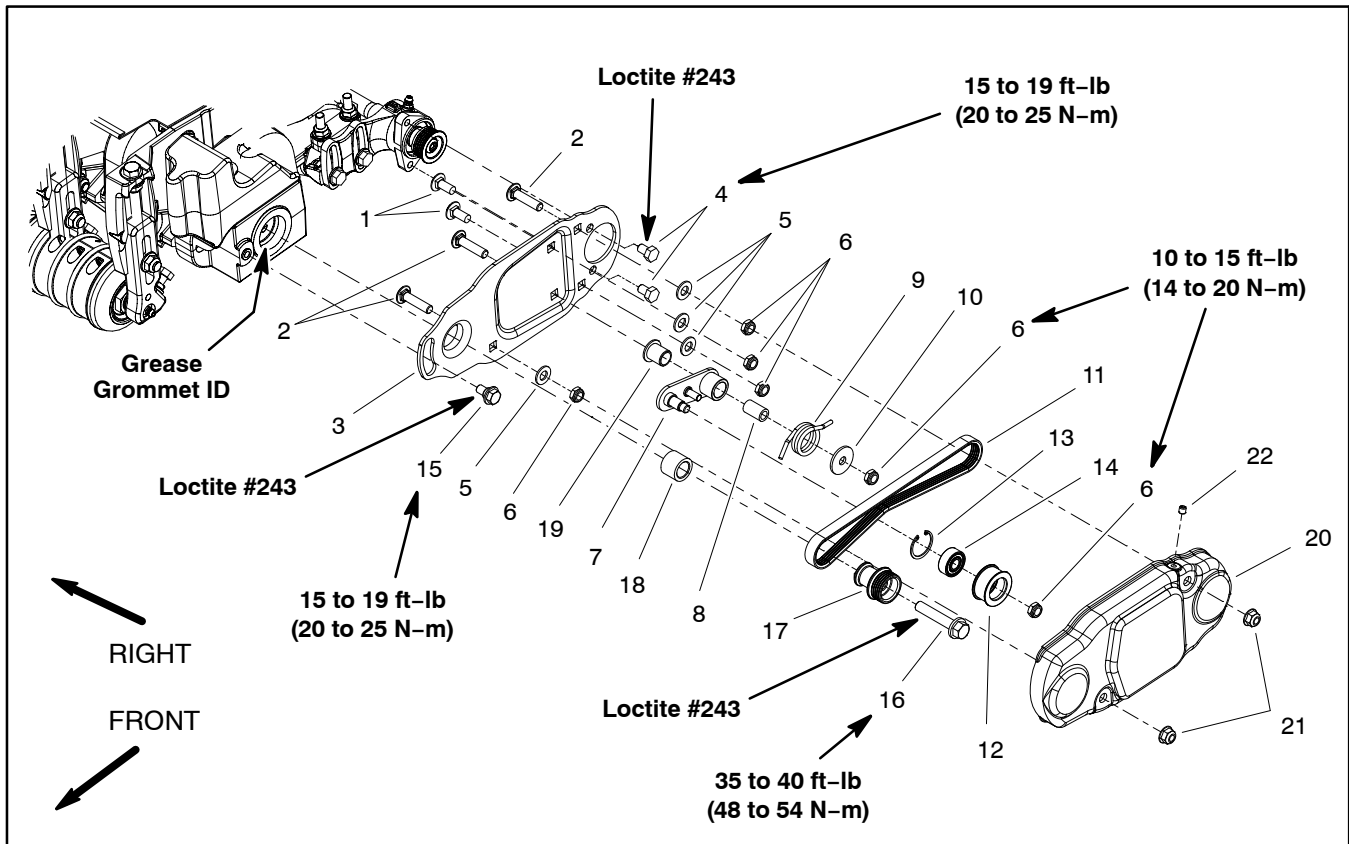

Figure 67

- | | | |
|----------------------------|--------------------|-----------------------------------|
| 1. Carriage screw (2 used) | 9. Idler spring | 16. Flange head screw |
| 2. Carriage screw (3 used) | 10. Pivot washer | 17. Drive pulley |
| 3. Brush plate | 11. Drive belt | 18. Spacer |
| 4. Cap screw (2 used) | 12. Idler pulley | 19. Flange bushing |
| 5. Flat washer (4 used) | 13. Retaining ring | 20. Cover |
| 6. Lock nut (6 used) | 14. Bearing | 21. Flange nut (2 used) |
| 7. Idler arm | 15. Shoulder screw | 22. Set screw (top of cover only) |
| 8. Idler spacer | | |

NOTE: Drive components for the rear roller brush are located on the opposite side of the cutting unit from the cutting reel motor. Figure 53 shows components used when the brush drive is on the left side of the cutting unit.

NOTE: The Installation Instructions for the rear roller brush kit has detailed information regarding assembly and adjustment. Use those Instructions along with this Service Manual when servicing the rear roller brush.

1. Position machine on a clean and level surface, lower cutting units, stop engine, engage parking brake and remove key from the ignition switch.
2. Remove cover (item 20) to access rear roller brush drive components.
3. Remove roller brush drive components as necessary using Figure 67 as a guide.

4. Remove roller brush drive shaft if needed:

A. Remove socket head screws that secure drive housing to cutting unit side plate and remove housing from cutting unit.

IMPORTANT: If rear roller brush drive is on left side of cutting unit, drive shaft has left hand threads and can be identified by a groove on the flange. If the rear roller brush drive is on right side of cutting unit, drive shaft has right hand threads and does not have a groove on the flange (Fig. 69).

B. Loosen and remove drive shaft from cutting reel.

Drive System Assembly (Fig. 67)

1. Install drive shaft if it was removed:

IMPORTANT: If rear roller brush drive is on left side of cutting unit, drive shaft has left hand threads and can be identified by a groove on the flange. If the rear roller brush drive is on right side of cutting unit, drive shaft has right hand threads and does not have a groove on the flange (Fig. 69).

A. Apply Loctite #243 (or equivalent) to threads of drive shaft. Thread drive shaft into cutting reel and torque from **85 to 95 ft-lb (115 to 128 N-m)**.

B. Make sure that O-ring is placed on inner flange of drive housing.

C. Position housing to cutting unit side plate and secure to cutting unit with two (2) socket head screws.

D. Make sure that grommet groove is correctly seated on flange in drive housing bore.

2. Assemble roller brush components using Figure 67 as a guide.

A. During assembly, apply Loctite #243 (or equivalent) to threads of fasteners and torque fasteners as shown in Figure 67.

B. Apply a light coating of grease to inner diameter of the grommet in drive bearing housing before installing brush plate.

C. Brush plate should be installed so that idler pulley assembly is toward the bottom of the plate. Also, the shoulder bolt (item 15) should not clamp the brush plate to the drive housing during assembly.

D. When installing drive pulley (item 17), make sure that tabs on pulley engage slot in drive shaft.

E. Idler arm (item 7) should be free to rotate after assembly to brush plate. Make sure that idler spring is installed so that it can rotate the idler arm and pulley and apply tension to the drive belt.

F. After drive belt installation, make sure that the ribs on the belt are properly seated in the grooves of both the drive and driven pulleys and that the belt is in the center of the idler pulley.

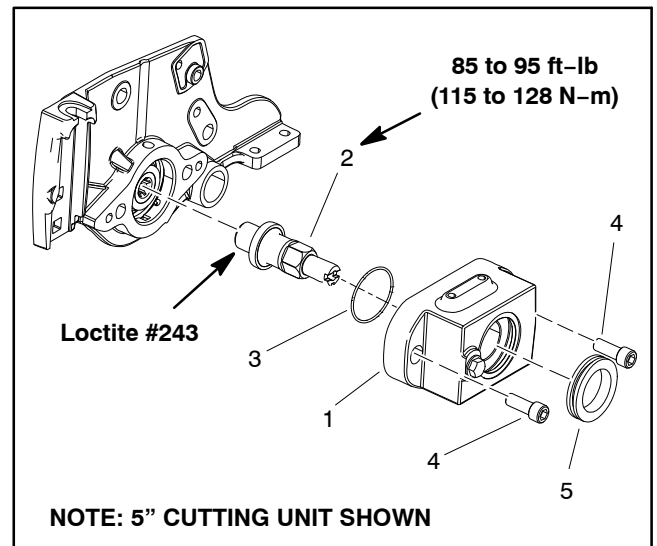

Figure 68

- | | |
|------------------|----------------------|
| 1. Drive housing | 4. Socket head screw |
| 2. Drive shaft | 5. Grommet |
| 3. O-ring | |

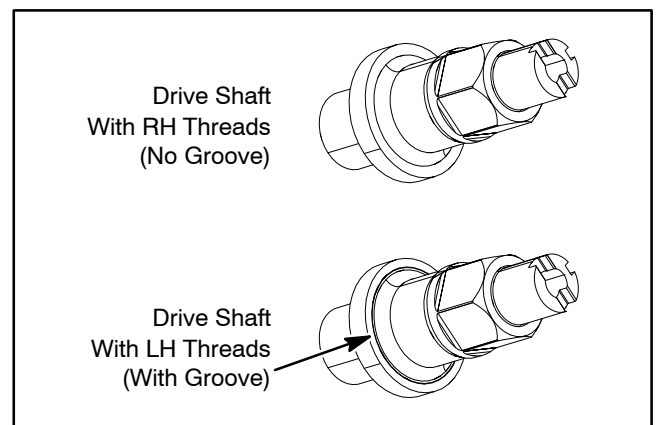

Figure 69

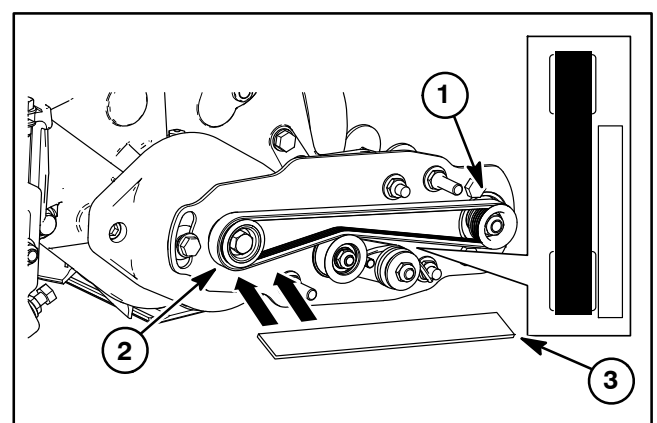

Figure 70

- | | |
|------------------|------------------|
| 1. Driven pulley | 3. Straight edge |
| 2. Drive pulley | |

DPA Cutting Units

3. After assembly (including drive belt installation), check alignment of pulleys with a straight edge placed along the outer face of the drive pulley (Fig. 59).

A. The outer faces of the drive and driven pulleys (not the idler pulley) should be in-line within 0.030" (0.76 mm).

B. If necessary to align pulleys, remove driven pulley from brush shaft and add or remove flat washer(s) until drive and driven pulleys are correctly aligned (Fig. 71).

C. If driven pulley was removed from roller brush shaft, apply antiseize lubricant to splines of pulley bore and slide pulley onto shaft. Install and tighten flange nut until pulley is seated onto shaft and then torque flange nut from **27 to 33 ft-lb (37 to 44 N-m)**. Use a 1/2 wrench on roller brush shaft flats to prevent shaft from rotating when tightening nut.

IMPORTANT: The roller brush shaft must not contact the cutting unit side plate. Also, heavy brush contact on the rear roller will cause premature brush wear.

4. Check that brush is parallel to rear roller with 0.060" (1.5 mm) clearance to light contact with rear roller. If contact is incorrect, brush operation will be adversely affected.

5. Install cover (item 20). There **should not** be a set screw installed in the bottom of the cover.

6. Lubricate grease fittings on brush housings until grease purges past inboard seals. Wipe excess grease from seals and fittings.

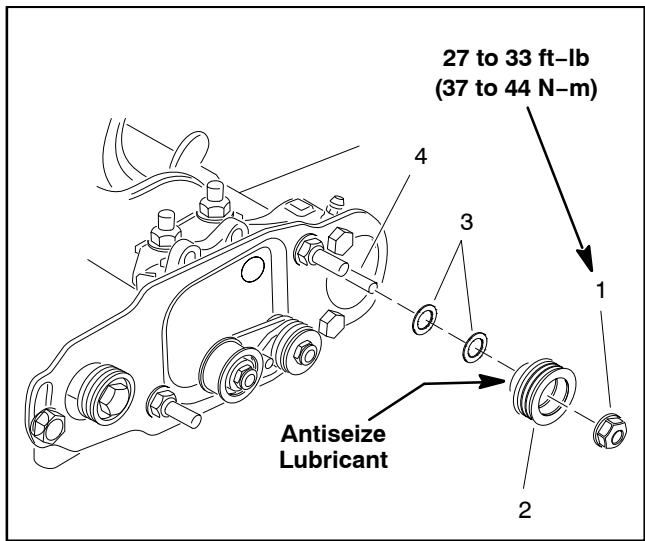

Figure 71

- | | |
|------------------|-----------------------|
| 1. Flange nut | 3. Flat washer |
| 2. Driven pulley | 4. Roller brush shaft |



Belt Driven Groomer (Optional)

Table of Contents

GROOMING PERFORMANCE	2
TROUBLESHOOTING	3
Groomer Reel Mechanical Problems	3
ADJUSTMENTS	4
Groomer Height/Depth Adjustment	4
SERVICE AND REPAIRS	5
Groomer Drive Belt Replacement	5
Groomer Plate Assembly	6
Groomer Reel	10
Groomer Reel Service	12
Groomer Pivot Hub	14
Height Adjuster Assembly	16

Grooming Performance

There are a number of factors that can affect the performance of grooming. These factors vary for different golf courses and from fairway to fairway. It is important to inspect the turf frequently and vary the grooming practice with turf needs.

IMPORTANT: Improper or overaggressive use of the groomer (e.g. too deep or too frequent grooming) may cause unnecessary stress on the turf leading to severe turf damage. Use the groomer carefully. READ AND UNDERSTAND THE GROOMER OPERATION INSTRUCTIONS BEFORE OPERATING OR TESTING GROOMER PERFORMANCE.

It is important to remember that factors affecting quality of cut also affect grooming performance.

Variables That Affect the Use and Performance of Groomers:

1. The growing season and weather conditions.
2. General turf conditions.
3. The frequency of grooming/cutting – number of cuttings per week and how many passes per cutting.
4. The height-of-cut.
5. The grooming depth.
6. The type of grass.
7. The amount of time that a groomer reel has been in use on a particular turf area.
8. The amount of traffic on the turf.
9. The overall turf management program – irrigation, fertilizing, weed control, coring, overseeding, sand dressing, disease control and pest control.
10. Stress periods for turf – high temperatures, high humidity, unusually high traffic.

Troubleshooting

Groomer Reel Mechanical Problems

Problem	Possible Causes	Correction
No rotation of the groomer reel.	<p>The groomer drive belt needs to be adjusted.</p> <p>Seized groomer reel or idler bearing(s) in groomer side plate(s).</p> <p>Broken or damaged idler spring.</p> <p>The groomer drive belt is worn, broken or damaged.</p> <p>Grooming depth is too deep.</p>	<p>Adjust groomer drive belt.</p> <p>Identify and replace faulty bearing(s).</p> <p>Replace spring.</p> <p>If the drive belt slips, it probably is out of adjustment or worn.</p> <p>Repair or replace drive belt if necessary. A broken or worn belt could be the result of improper belt routing or seized bearings in groomer assembly.</p> <p>Change grooming depth.</p>
The turf is damaged or has uneven grooming.	<p>The groomer reel blades are bent, damaged or missing.</p> <p>The groomer reel shaft is bent or damaged.</p> <p>Grooming depth is not equal on both ends of groomer reel.</p>	<p>Repair or replace blades if necessary.</p> <p>Replace groomer reel shaft.</p> <p>Adjust depth if necessary. Check and adjust cutting unit set up (level bedknife to reel, level rear roller to reel, set height-of-cut, etc.).</p>

Adjustments



CAUTION

Never work on the groomer with the engine running. Always stop the engine, remove the key from the ignition switch and wait for all machine movement to stop before working on the groomer.

NOTE: The Groomer Installation Instructions provide information regarding the installation, set-up and operation of the optional groomer on your Reelmaster machine. Refer to these instructions for additional information when servicing the groomer.

Groomer Height/Depth Adjustment

NOTE: Grooming is performed above the soil level. When adjusting groomer height/depth, groomer blades should never penetrate the soil.

1. Park machine on a clean and level surface, lower cutting units completely to the ground, stop engine, engage parking brake and remove key from the ignition switch.
2. Make sure rollers are clean and cutting unit is set to the desired height-of-cut (see Cutting Unit Operator's Manual).
3. Place the groomer reel in the grooming (lowered) position by rotating the raise/lower lever toward the front of the cutting unit (Fig. 1).

NOTE: Improper or over-aggressive use of the groomer (e.g. too deep or too frequent grooming) may cause unnecessary stress on the turf leading to severe turf damage. Use the groomer cautiously.

4. On one end of the groomer reel, measure the distance from the lowest tip of the groomer blade to the working surface. Turn groomer height adjuster to raise or lower the groomer blade tip to the desired height (Fig. 1).
5. Repeat step 4 on the opposite end of the groomer. Then, recheck setting on the first side of groomer. Height setting on both ends of groomer should be identical.

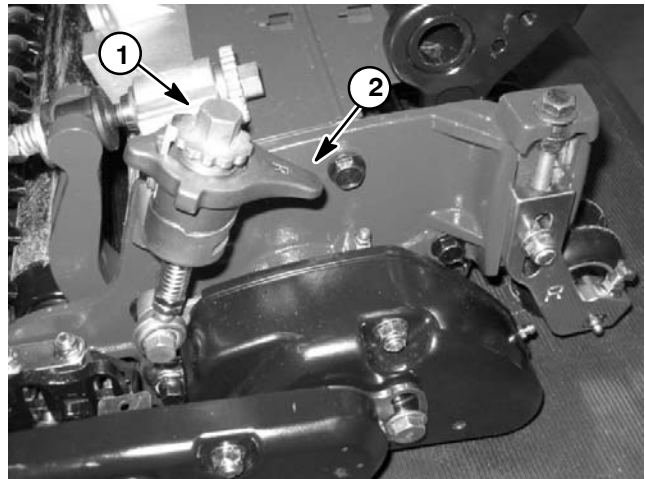

Figure 1

1. Groomer height adjuster 2. Raise/lower lever

Service and Repairs



CAUTION

Never work on the groomer with the engine running. Always stop the engine, remove the key from the ignition switch and wait for all machine movement to stop before working on the groomer.

NOTE: The Groomer Installation Instructions provide information regarding the installation, set-up and operation of the optional groomer on your Reelmaster machine. Refer to these instructions for additional information when servicing the groomer.

Groomer Drive Belt Replacement

The groomer drive belt should be inspected/replaced annually or after 750 hours of operation.

1. Park machine on a clean and level surface, lower cutting units completely to the ground, stop engine, engage parking brake and remove key from the ignition switch.

NOTE: If cutting unit is equipped with powered rear roller brush, removal of roller brush components will be necessary to replace groomer drive belt (see Roller Brush (Optional) in the Service and Repairs section of Chapter 7 – Cutting Units).

NOTE: When removing groomer cover, groomer weight does not have to be removed from cover.

2. Remove two (2) flange nuts that secure groomer cover, then remove cover (Fig. 2).

3. Remove groomer belt tension by pivoting idler plate and pulley using a wrench on pulley nut. Slip groomer drive belt off pulleys (Fig. 3). Carefully release idler plate and pulley.

4. Install new drive belt to drive pulley, idler pulley and driven pulley observing correct belt routing (Fig. 3). Make sure that groomer drive belt is above idler pulley after belt installation.

5. Install groomer cover and secure with two (2) flange nuts.

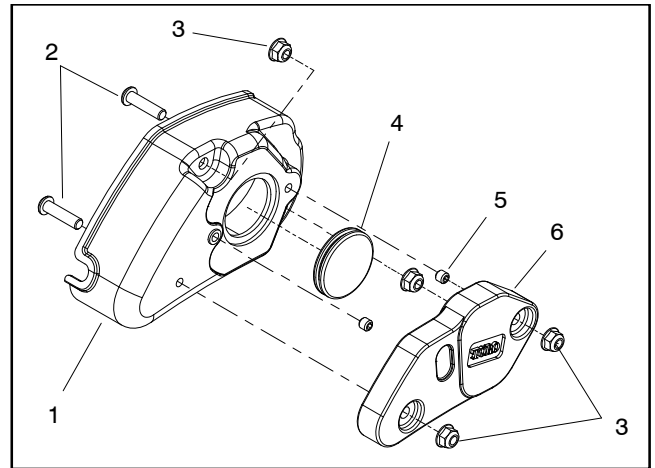

Figure 2

- | | |
|----------------------|-------------------|
| 1. Groomer cover | 4. Rubber grommet |
| 2. Socket head screw | 5. Set screw |
| 3. Flange nut | 6. Groomer weight |

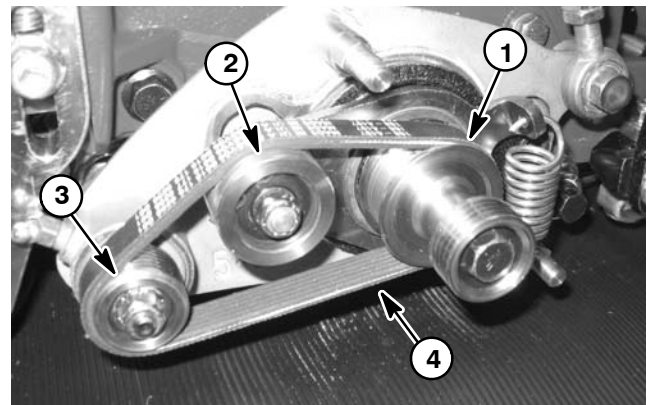

Figure 3

- | | |
|-----------------|-----------------------|
| 1. Drive pulley | 3. Driven pulley |
| 2. Idler pulley | 4. Groomer drive belt |

Belt Driven Groomer (Opt.)

Groomer Plate Assembly

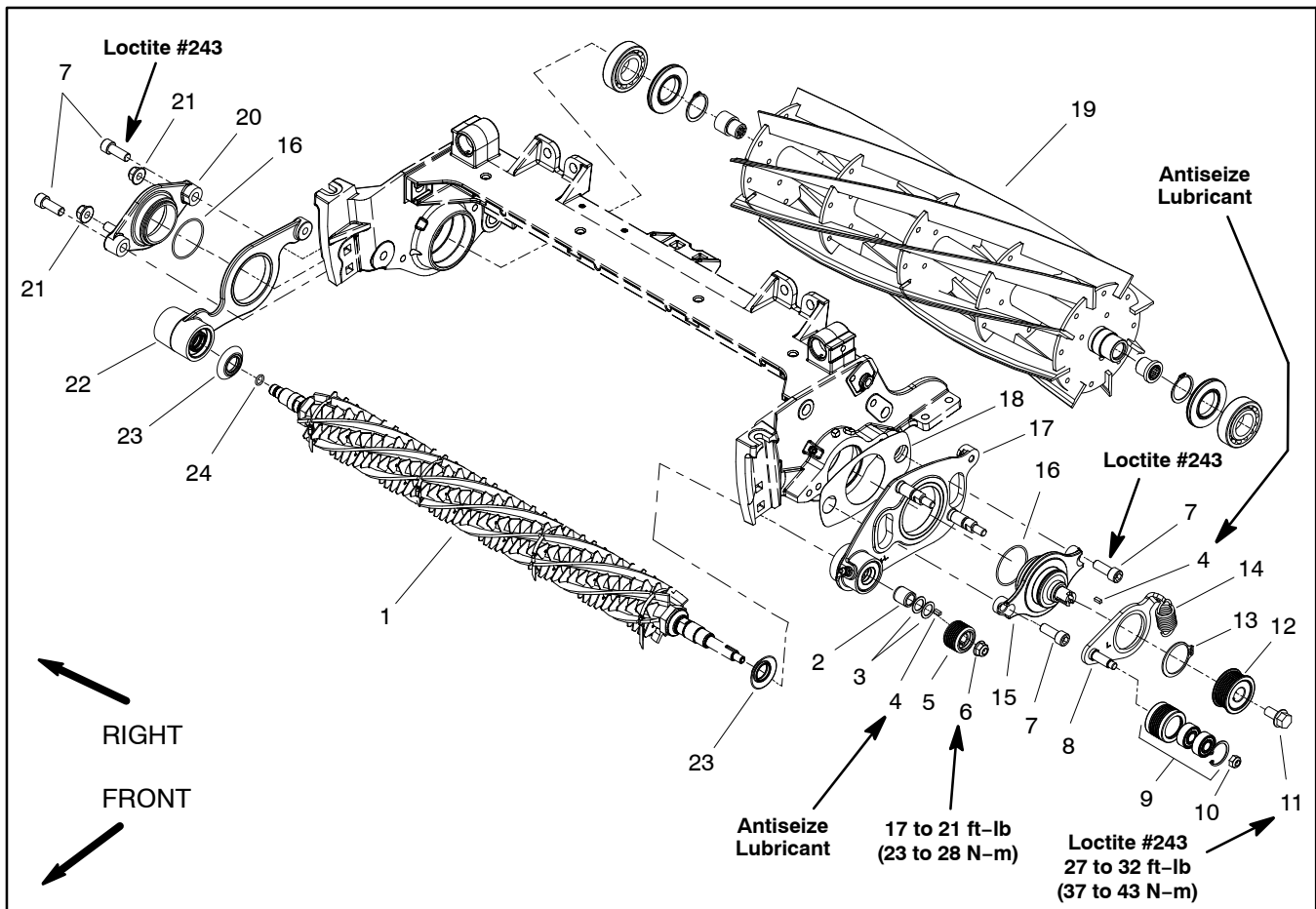

Figure 4

- | | | |
|-------------------------|--------------------------------|------------------------------------|
| 1. Groomer reel | 9. Idler pulley assembly | 17. Groomer plate (drive) |
| 2. Pulley spacer | 10. Lock nut | 18. Groomer shim |
| 3. Washer (as required) | 11. Flange head screw | 19. Cutting reel |
| 4. Square key | 12. Drive pulley | 20. Pivot hub assembly (non-drive) |
| 5. Driven pulley | 13. Retaining ring | 21. Flange nut |
| 6. Flange nut | 14. Extension spring | 22. Groomer plate (non-drive) |
| 7. Socket head screw | 15. Pivot hub assembly (drive) | 23. Excluder seal |
| 8. Idler plate | 16. O-ring | 24. O-ring |

NOTE: The groomer reel drive is located on the opposite side of the cutting unit from the cutting reel hydraulic motor. Figure 4 shows components used when the groomer reel drive is on the left side of the cutting unit.

Removal (Fig. 4)

1. Park machine on a clean and level surface, lower cutting units completely to the ground, stop engine, engage parking brake and remove key from the ignition switch.

NOTE: If cutting unit is equipped with powered rear roller brush, removal of roller brush components will be necessary to service groomer plate assemblies (see Roller Brush (Optional) in the Service and Repairs section of Chapter 7 – Cutting Units).

2. To remove groomer plate assembly from groomer drive side of cutting unit:

A. Remove groomer belt cover and groomer drive belt from groomer drive (see Groomer Belt Replacement in this section).

NOTE: To prevent cutting reel from turning when removing drive pulley, block reel with piece of wood.

B. Remove flange head screw (item 11) that retains drive pulley. Pull drive pulley from drive shaft. Locate and retrieve square key (item 4) from drive shaft.

NOTE: To prevent groomer shaft from turning when removing driven pulley, use wrench on shaft flats to hold groomer shaft.

C. Remove the flange nut (item 6) that secures driven pulley (item 5) to groomer shaft. Remove driven pulley from shaft. Locate and retrieve square key (item 4) that locates driven pulley on shaft.

D. Slide washer (item 3) and pulley spacer (item 2) from groomer shaft.

E. Remove shoulder bolt that secures quick-up ball joint rod to groomer plate (Fig. 10).

F. Disconnect extension spring (item 14) from stud on groomer plate.

G. Remove two (2) socket head screws (item 7) that secure groomer components to cutting unit side plate.

H. Remove pivot hub and idler plate assembly from cutting unit.

I. Support groomer shaft to prevent it from falling. Carefully slide drive side groomer plate from groomer shaft and cutting unit. Remove groomer shim.

3. To remove groomer plate assembly from groomer non-drive side of cutting unit:

A. Remove hydraulic reel motor from cutting unit (see Hydraulic Reel Motor Removal in the Service and Repairs section of Chapter 7 – Cutting Units).

B. Remove two (2) socket head screws (item 7) that secure groomer components to cutting unit side plate.

C. Remove pivot hub from cutting unit.

D. Support groomer shaft to prevent it from falling. Carefully slide non-drive side groomer plate from groomer shaft and cutting unit.

4. Inspect seals, bearings and bushing in groomer plates. Remove and discard damaged or worn components.

Installation (Fig. 4)

1. If seals, bearings or bushing was removed from groomer plates, install new components noting proper orientation as shown in Figure 5.

A. Pack bearings with grease before installation.

B. Press bearings into groomer plate so that bearings contact shoulder in groomer plate bore.

C. Install grease seals so that seal lips are positioned toward the groomer blade location. Seals should be flush with surface of groomer plate.

D. Press bushings into groomer plate until the bushing contacts the shoulder in the groomer plate bore.

E. If groomer studs (not shown) were removed from groomer plate (item 17), install new studs into groomer plate and torque from **14 to 18 ft-lb (19 to 24 N-m)**.

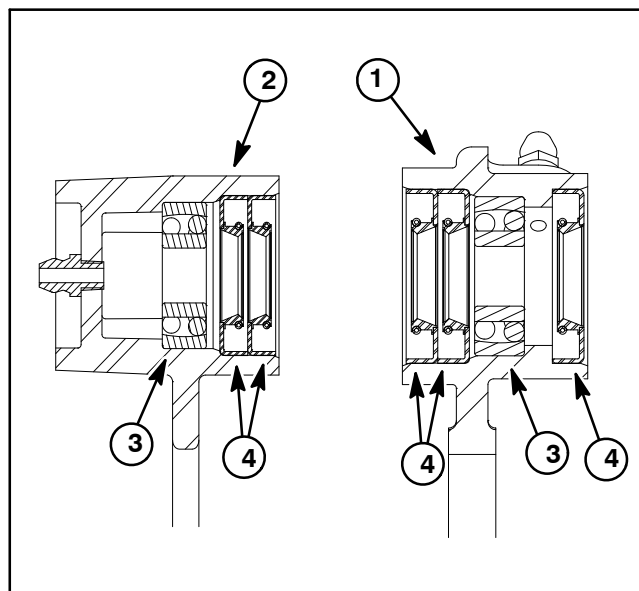

Figure 5

- | | |
|-----------------------------|----------------|
| 1. Drive side groomer plate | 3. Bearing |
| 2. Non-drive groomer plate | 4. Grease seal |

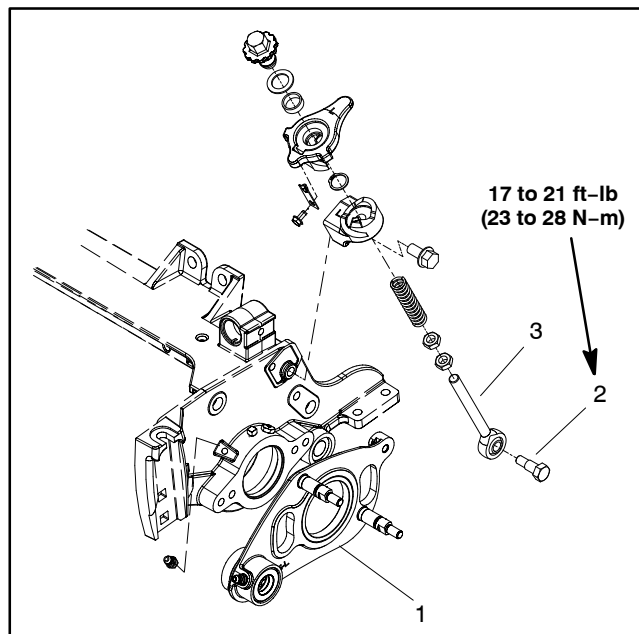

Figure 6

- | | |
|------------------|----------------------------|
| 1. Groomer plate | 3. Quick-up ball joint rod |
| 2. Shoulder bolt | |

Belt Driven Groomer (Opt.)

2. Install groomer plate assembly to groomer non-drive side of cutting unit:

A. Carefully position non-drive side groomer plate onto groomer shaft and slide to cutting unit.

B. Position pivot hub to cutting unit.

C. Secure groomer components to cutting unit side plate with two (2) socket head screws (item 7).

D. Install hydraulic reel motor to cutting unit (see Hydraulic Reel Motor Installation in the Service and Repairs section of Chapter 7 – Cutting Units).

3. Install groomer plate assembly to groomer drive side of cutting unit:

A. Position groomer shim to cutting unit side plate. Carefully position drive side groomer plate onto groomer shaft and slide to cutting unit.

B. Position pivot hub and idler plate assembly to cutting unit side plate and secure with two (2) socket head screws (item 7).

C. Connect extension spring (item 14) to stud on groomer plate. Make sure that spring is in the stud groove and that spring hook is positioned toward the drive pulley.

D. Secure quick-up ball joint rod to drive side groomer plate with shoulder bolt (Fig. 6). Torque shoulder bolt from **17 to 21 ft-lb (23 to 28 N-m)**.

E. Slide pulley spacer (item 2) and washer (item 3) onto groomer shaft.

F. Apply antiseize lubricant to square keys (item 4) that locate drive and driven pulleys. Position keys into shaft slots.

NOTE: To prevent cutting reel from turning when installing drive pulley, block cutting reel with piece of wood.

G. Apply Loctite #243 to threads of flange head screw that secures drive pulley to pivot hub shaft. Slide drive pulley onto shaft and secure with flange head screw. Torque screw from **27 to 32 ft-lb (37 to 43 N-m)**.

NOTE: To prevent groomer shaft from turning when installing driven pulley, use wrench on groomer shaft flats.

H. Slide driven pulley onto groomer shaft and secure with flange nut. Torque flange nut from **17 to 21 ft-lb (23 to 28 N-m)**.

I. Check pulley alignment by laying a straight edge along the outer face of the drive pulley (Fig. 7). Drive and driven pulleys should be in line within 0.030" (0.76 mm). If necessary, align pulleys by removing driven pulley and installing or removing washer(s) (item 3) between pulley and pulley spacer.

J. After pulleys are aligned, install groomer drive belt and groomer belt cover (see Groomer Belt Replacement in this section).

4. Check that excluder seals just touch groomer plate assembly. Reposition excluder seals on groomer shaft if necessary.

5. Check groomer reel height and mower height-of-cut settings. Adjust as needed.

6. Lubricate groomer bearings.

NOTE: After greasing groomer bearings, operate groomer for 30 seconds, stop machine and wipe excess grease from groomer shaft and seals.

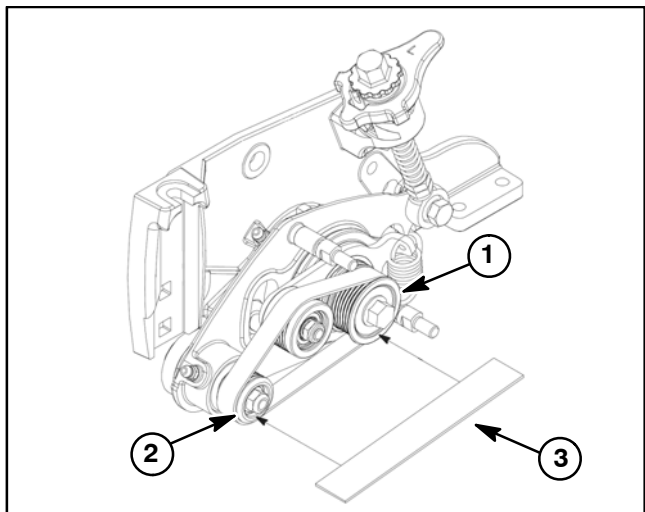

Figure 7

- 1. Drive pulley
- 2. Driven pulley
- 3. Straight edge

This page is intentionally blank.

Groomer Reel

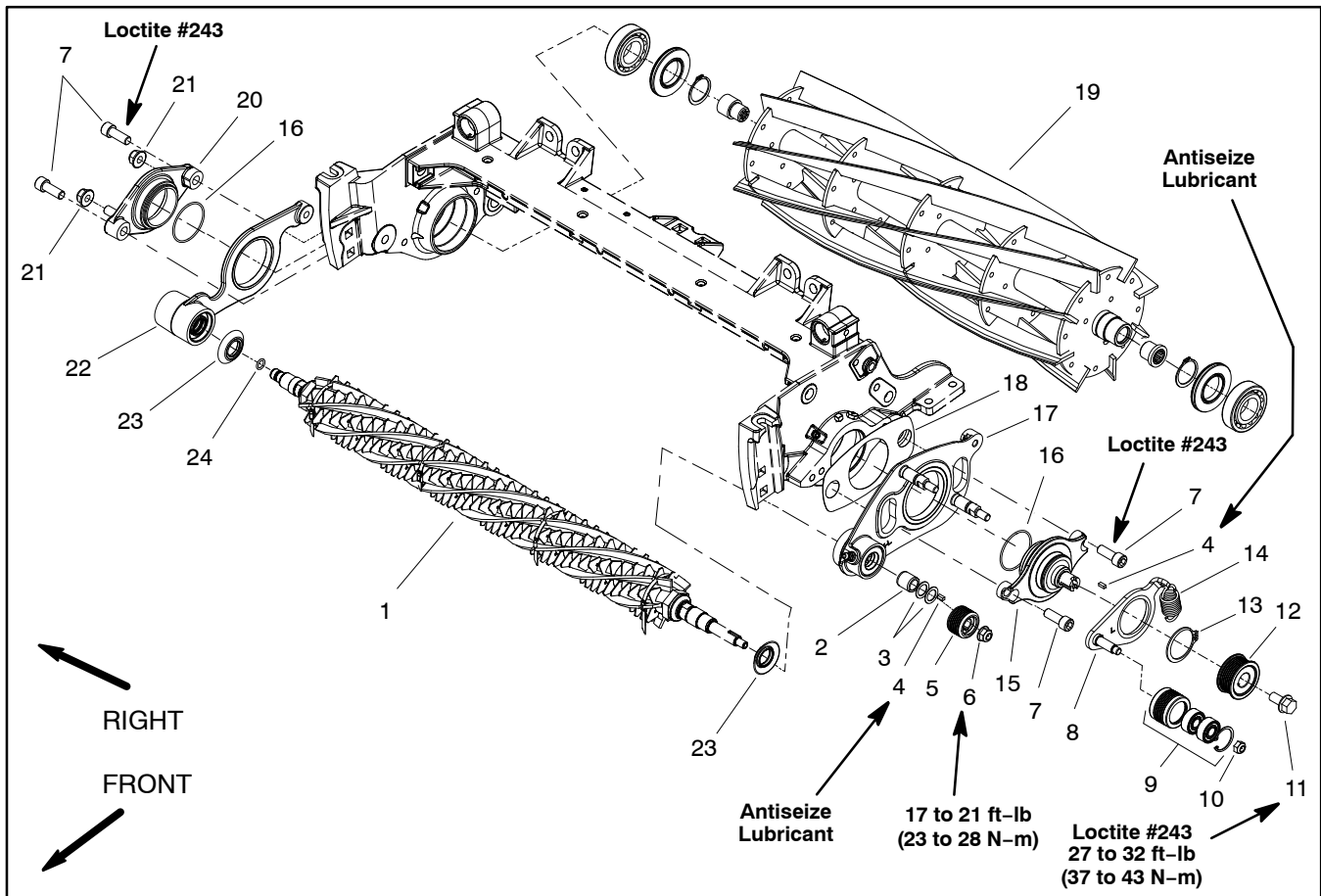

Figure 8

- | | | |
|----------------------|--------------------------------|------------------------------------|
| 1. Groomer reel | 9. Idler pulley assembly | 17. Groomer plate (drive) |
| 2. Pulley spacer | 10. Lock nut | 18. Groomer shim |
| 3. Washer | 11. Flange head screw | 19. Cutting reel |
| 4. Square key | 12. Drive pulley | 20. Pivot hub assembly (non-drive) |
| 5. Driven pulley | 13. Retaining ring | 21. Flange nut |
| 6. Flange nut | 14. Extension spring | 22. Groomer plate (non-drive) |
| 7. Socket head screw | 15. Pivot hub assembly (drive) | 23. Excluder seal |
| 8. Idler plate | 16. O-ring | 24. O-ring |

Remove the groomer reel to replace individual groomer blades or replace the shaft. The groomer blades can be reversed on the shaft to provide additional blade life.

NOTE: The groomer reel drive is located on the opposite side of the cutting unit from the reel hydraulic motor. Figure 8 shows the groomer reel drive on the left side of the cutting unit.

Removal (Fig. 8)

1. Park machine on a clean and level surface, lower cutting units completely to the ground, stop engine, engage parking brake and remove key from the ignition switch. If desired, remove cutting unit from machine (see Traction Unit Operator's Manual).

NOTE: If cutting unit is equipped with powered rear roller brush, removal of roller brush components will be necessary to remove groomer reel (see Roller Brush (Optional) in the Service and Repairs section of Chapter 7 – Cutting Units).

2. Remove groomer plate assembly from groomer drive side of cutting unit (see Groomer Plate Assembly Removal in this section).

3. Carefully pull the groomer reel from the non-drive side groomer plate assembly.

4. Inspect all seals, bushings and bearings in groomer plate assemblies for wear or damage. Replace components as needed (see Groomer Plate Assembly in this section).

Installation (Fig. 8)

1. Position cutting unit on a level surface. If cutting unit is attached to traction unit, make sure to stop engine, engage parking brake and remove key from the ignition switch.

2. Apply a light coating of grease to seal lips in groomer plate assemblies.

3. Make sure that excluder seals (item 23) and O-ring (item 24) are positioned on groomer shaft. The excluder seal lips should be toward the end of the groomer shaft. Apply a film of grease onto seal lip.

4. Carefully slide the groomer reel into the non-drive side groomer plate assembly taking care not to damage seals in groomer plate assembly.

5. Carefully install groomer plate assembly to groomer reel and groomer drive side of cutting unit (see Groomer Plate Assembly Installation in this section).

6. Check that excluder seals just touch groomer plate assembly (Fig. 10). Reposition excluder seals on groomer shaft if necessary.

7. Check groomer reel height and mower height-of-cut settings. Adjust as needed.

8. Lubricate groomer bearings.

NOTE: After greasing groomer bearings, operate groomer for 30 seconds, stop machine and wipe excess grease from groomer shaft and seals.

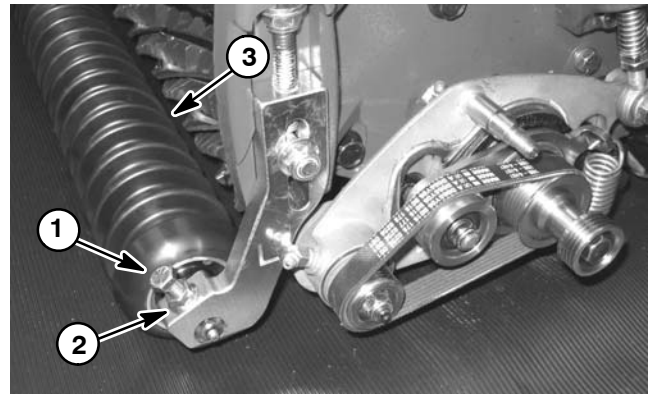

Figure 9

- 1. Cap screw
- 2. Flange nut
- 3. Front roller

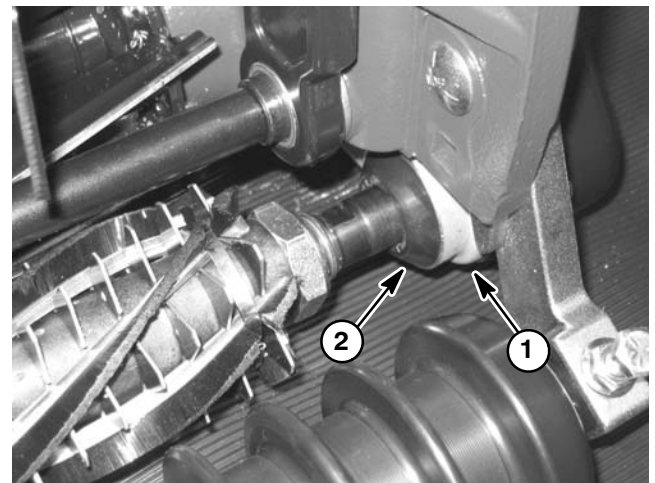

Figure 10

- 1. Groomer plate
- 2. Excluder seal

Groomer Reel Service

Inspect groomer reel blades frequently for damage and wear. Straighten bent blades with a pliers. Either replace worn blades or reverse the blades to put the sharpest blade edge forward (Fig. 11). Blades that are rounded to the midpoint of the blade tip must be reversed or replaced for best groomer performance.

Groomer shafts are either hex shaped or splined so two styles of groomer blades are available. The blade shown in Figure 11 is for the hex shaft and the blade shown in Figure 12 is for the splined shaft.

Disassembly (Fig. 13)

1. Park machine on a clean and level surface, lower cutting units completely to the ground, stop engine, engage parking brake and remove key from the ignition switch.
2. Remove groomer reel from cutting unit (see Groomer Reel Removal in this section).
3. Remove excluder seals from groomer reel.
4. If groomer reel is equipped with broomer kit (Fig. 14), remove straps and broomer brushes from reel.
5. Remove lock nut from either end of the shaft (Fig. 13).
6. Remove spacers and blades from groomer shaft. If needed, remove second lock nut from shaft.
7. If necessary, remove groomer shaft ends from groomer shaft.

Assembly (Fig. 13)

1. Install lock nut on drive end of groomer shaft. Place first spacer and then first blade on shaft.
2. Alternately install remaining spacers and blades making sure that all blades are separated by a spacer. Additionally, if groomer shaft has a hex shape, rotate location hole on each installed blade one flat of the shaft, in a counterclockwise direction.
3. When all blades have been installed, place final spacer on shaft and then thread second lock nut onto the shaft. Center blades on shaft with lock nuts.
4. Using wrench on shaft flats to prevent shaft from turning, torque second lock nut from **200 to 250 in-lb (23 to 28 N-m)**. After torquing lock nut, spacers should **not** be free to rotate and groomer blades should be centered on shaft.

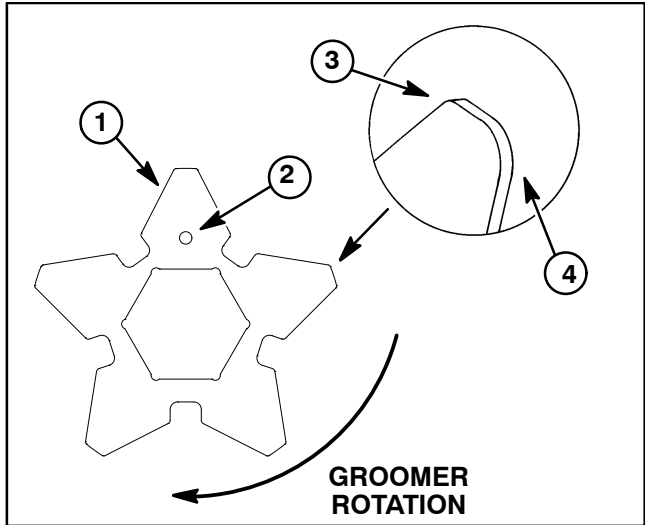

Figure 11

- | | |
|------------------|------------------------|
| 1. Groomer blade | 3. Sharp edge |
| 2. Location hole | 4. Dull (rounded) edge |

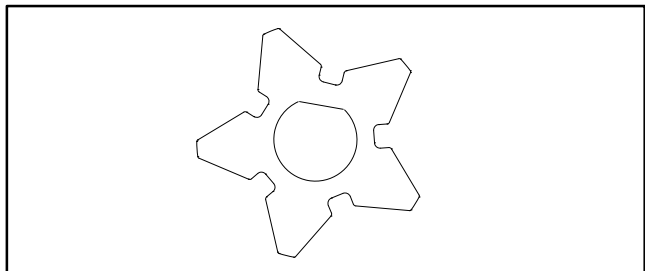

Figure 12

1. Groomer blade for splined shaft

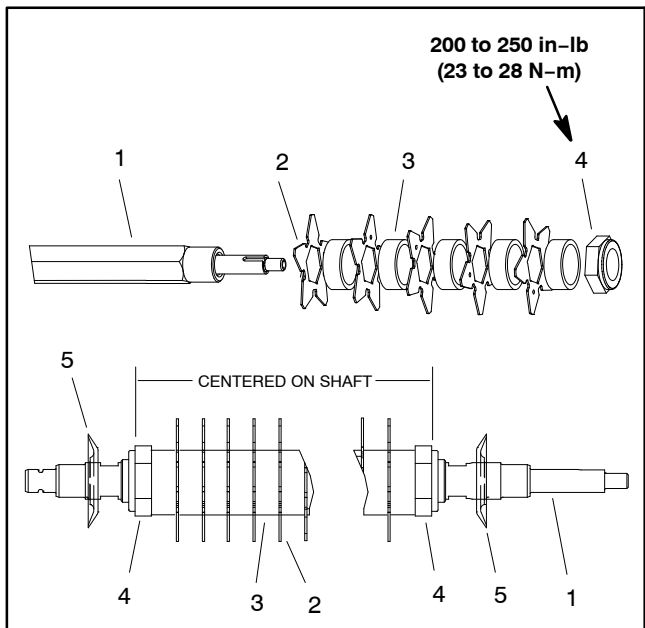

Figure 13

- | | |
|----------------------------|----------------------|
| 1. Groomer reel shaft | 4. Lock nut (2 used) |
| 2. Groomer blade (42 used) | 5. Excluder seal |
| 3. Spacer (43 used) | |

5. If groomer reel is equipped with broomer kit (Fig. 14), position broomer brushes to reel blades and secure with straps. Straps should be positioned between blades 1–2, 14–15, 28–29 and 41–42. Pull straps tight and cut off strap extension approximately 1/4" (6 mm) beyond retainer.

6. Place excluder seals on groomer shaft.

7. Install O-ring on non-drive end of groomer shaft.

8. Install groomer reel back on cutting unit (see Groomer Reel Installation in this section).

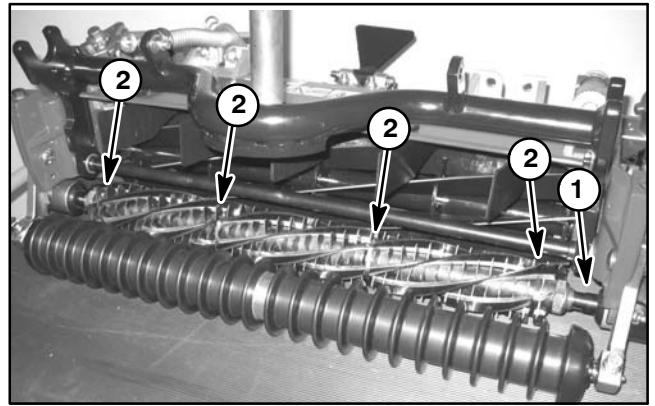

Figure 14

1. Groomer shaft

2. Broomer strap

Groomer Pivot Hub

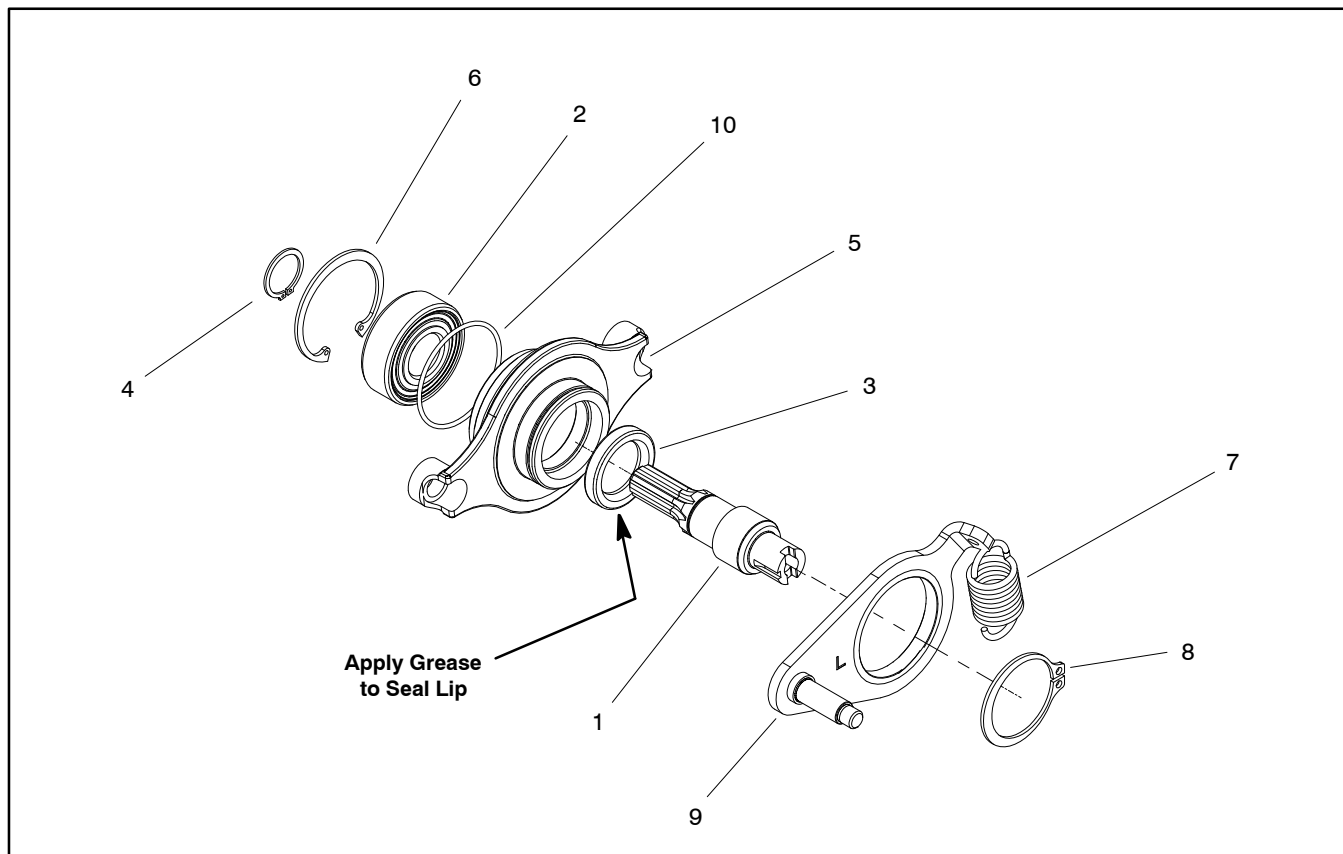

Figure 15

- | | | |
|------------------------|---------------------|-----------------------------------|
| 1. Groomer drive shaft | 5. Pivot hub | 8. Retaining ring |
| 2. Ball bearing | 6. Retaining ring | 9. Idler plate |
| 3. Grease seal | 7. Extension spring | 10. O-ring (7" cutting unit only) |
| 4. Retaining ring | | |

NOTE: The groomer reel drive is located on the opposite side of the cutting unit from the cutting reel hydraulic motor. Figure 15 shows components used when the groomer reel drive is on the left side of the cutting unit.

Disassembly (Fig. 15)

1. Remove pivot hub assembly (with idler plate) from cutting unit (see Groomer Plate Assembly Removal in this section).
2. Remove retaining ring (item 4) that secures idler plate to pivot hub. Slide idler plate from pivot hub.
3. Remove retaining ring (item 8) that retains ball bearing into pivot hub. Slide drive shaft and bearing out of hub.
4. Remove retaining ring (item 7) that retains bearing on drive shaft. Press ball bearing from shaft. Discard bearing.
5. Remove grease seal from pivot hub. Discard seal.
6. On 7" cutting units, remove and discard O-ring (item 10) from flange of pivot hub.
7. Clean all pivot hub components and inspect for wear or damage.

Assembly (Fig. 15)

1. Install bearing on drive shaft by pressing equally on the inner and outer bearing races. Install the bearing so that the bearing seal is closest to the shoulder on the shaft. Install retaining ring (item 7) onto shaft to retain bearing.
2. Install new grease seal into housing with the lip of the seal toward the outside of the housing. Apply grease to lip of seal.
3. Fill cavity between bearing location and grease seal 50% to 75% full with high temperature Mobil XHP-222 grease (or equivalent) (Fig. 16).
4. Carefully slide shaft and bearing fully into pivot hub bore taking care to not damage the grease seal. Install retaining ring (item 8) to secure bearing in pivot hub.
5. Install new O-ring (item 10) into groove in pivot hub flange.
6. Slide idler plate onto pivot hub and secure with retaining ring (item 4).
7. Install pivot hub and idler plate assembly to cutting unit (see Groomer Plate Assembly Installation in this section).

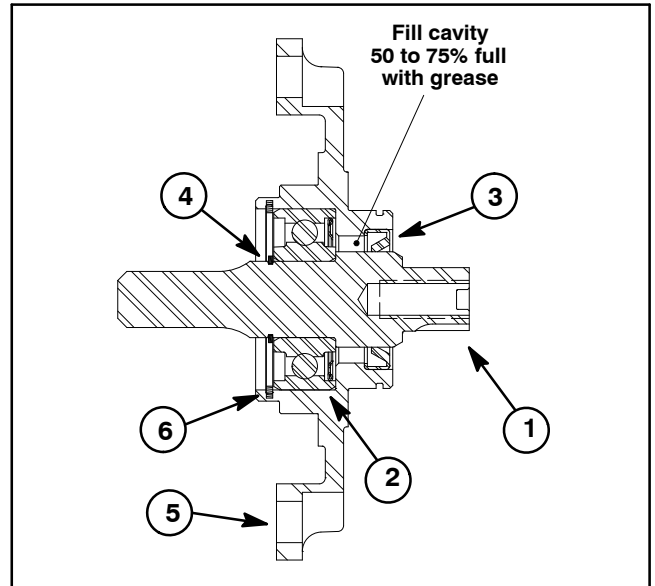

Figure 16

- | | |
|----------------|-------------------|
| 1. Drive shaft | 4. Retaining ring |
| 2. Bearing | 5. Pivot hub |
| 3. Oil seal | 6. Retaining ring |

Height Adjuster Assembly

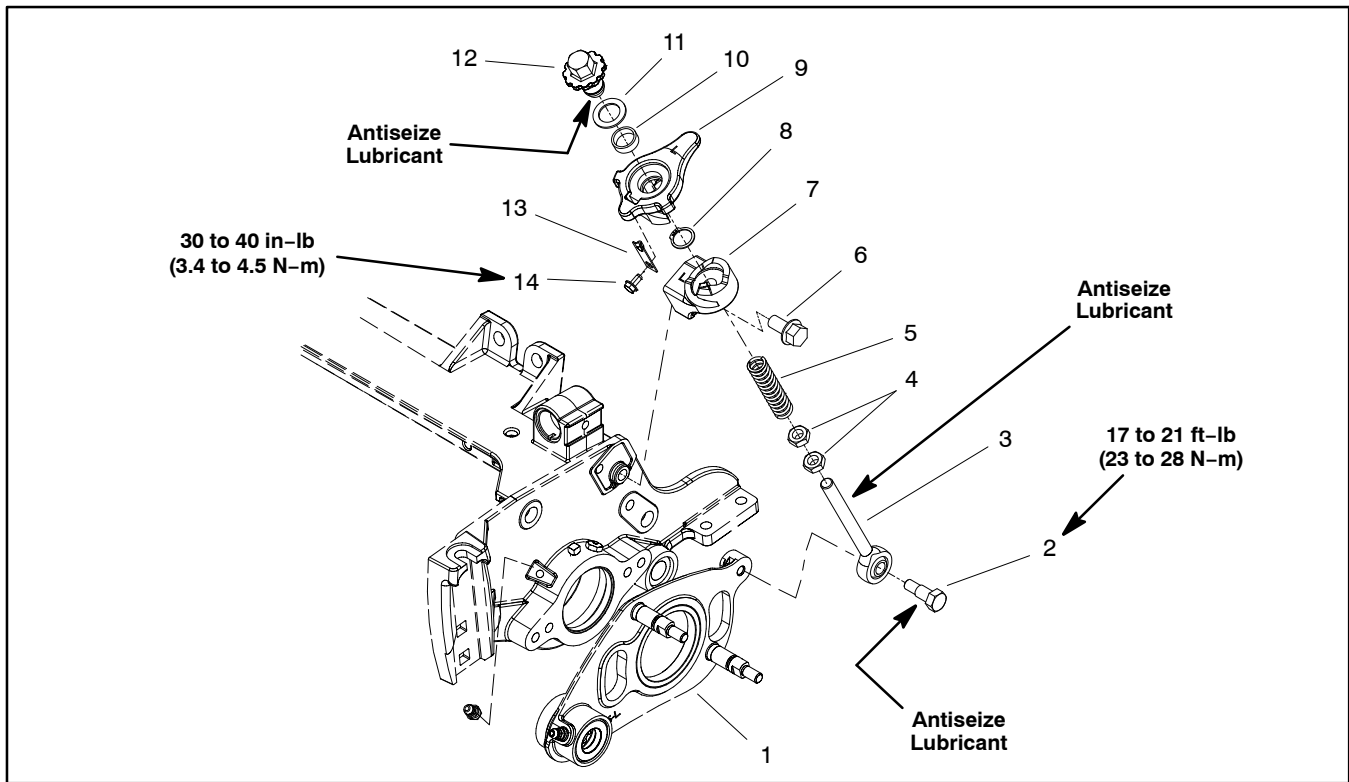

Figure 17

- | | | |
|-----------------------------------|-----------------------|-----------------------|
| 1. Groomer plate (LH drive shown) | 6. Flange head screw | 11. Flat washer |
| 2. Shoulder bolt | 7. Lower ramp | 12. Groomer adjuster |
| 3. Ball joint rod | 8. External snap ring | 13. Detent spring |
| 4. Jam nut | 9. Upper ramp | 14. Washer head screw |
| 5. Compression spring | 10. Bushing | |

NOTE: The groomer reel drive is located on the opposite side of the cutting unit from the cutting reel hydraulic motor. Figure 17 shows components used when the groomer reel drive is on the left side of the cutting unit.

Disassembly (Fig. 17)

1. Park machine on a clean and level surface, lower cutting units completely to the ground, stop engine, engage parking brake and remove key from the ignition switch.
2. Disassemble height adjuster using Figure 17 as a guide.
3. Clean all components and inspect for wear or damage. Replace all worn or damaged components.

Assembly (Fig. 17)

1. Assemble height adjuster using Figure 17 as a guide noting the following items:

A. If bushing (item 10) was removed from upper ramp, press new bushing into housing fully to the shoulder in the bore.

B. If jam nuts (item 4) were removed from ball joint rod, apply antiseize lubricant to threads of rod where jam nuts will be positioned. Install jam nuts so that distance from end of ball joint rod to top of upper nut is from 3.060" to 3.180" (7.8 to 8.0 cm).

C. Apply antiseize lubricant to threads of groomer adjuster (item 12) before installing it on threads of ball joint rod.

D. If detent spring (item 13) was removed, secure detent spring to upper ramp with washer head screw. Torque screw from **30 to 40 in-lb (3.4 to 4.5 N-m)**.

2. Secure ball joint rod to groomer plate with shoulder bolt (item 2). Torque shoulder bolt from **17 to 21 ft-lb (23 to 28 N-m)**.

3. Check groomer reel height and adjust as needed.

4. After groomer height has been adjusted, adjust location of jam nuts so compression spring length is 1.375" (3.5 cm) when the groomer handle is in the disengaged position (handle toward rear of cutting unit).



Universal Groomer (Optional)

Table of Contents

GROOMING PERFORMANCE	2
TROUBLESHOOTING	3
Groomer Reel Mechanical Problems	3
SERVICE AND REPAIRS	4
Gear Box Assembly	6
Idler Assembly	12
Groomer Reel	14
Groomer Reel Service	15
Grooming Brush (Optional)	17
Height Adjuster Assembly	18

Grooming Performance

There are a number of factors that can affect the performance of grooming. These factors vary for different golf courses and from fairway to fairway. It is important to inspect the turf frequently and vary the grooming practice with turf needs.

IMPORTANT: Improper or overaggressive use of the groomer (e.g. too deep or too frequent grooming) may cause unnecessary stress on the turf leading to severe turf damage. Use the groomer carefully. **READ AND UNDERSTAND THE GROOMER OPERATION INSTRUCTIONS BEFORE OPERATING OR TESTING GROOMER PERFORMANCE.**

It is important to remember that factors affecting quality of cut also affect grooming performance.

Variables That Affect the Use and Performance of Groomers:

1. The growing season and weather conditions.
2. General turf conditions.
3. The frequency of grooming/cutting – number of cuttings per week and how many passes per cutting.
4. The height-of-cut.
5. The grooming depth.
6. The type of grass.
7. The amount of time that a groomer reel has been in use on a particular turf area.
8. The amount of traffic on the turf.
9. The overall turf management program – irrigation, fertilizing, weed control, coring, over-seeding, sand dressing, disease control and pest control.
10. Stress periods for turf – high temperatures, high humidity, unusually high traffic.

Troubleshooting

Groomer Reel Mechanical Problems

Problem	Possible Causes	Correction
No rotation of the groomer reel.	The groomer drive is in Neutral. Damaged or seized groomer drive gears.	Engage groomer drive to Forward or Reverse. Repair groomer drive.
The turf is damaged or has uneven grooming.	The groomer reel blades are bent, damaged or missing. The groomer reel shaft is bent or damaged. Grooming depth is not equal on both ends of groomer reel.	Repair or replace blades if necessary. Replace groomer reel shaft. Adjust depth if necessary. Check and adjust cutting unit set up (level bedknife to reel, level rear roller to reel, set height-of-cut, etc.).

Service and Repairs

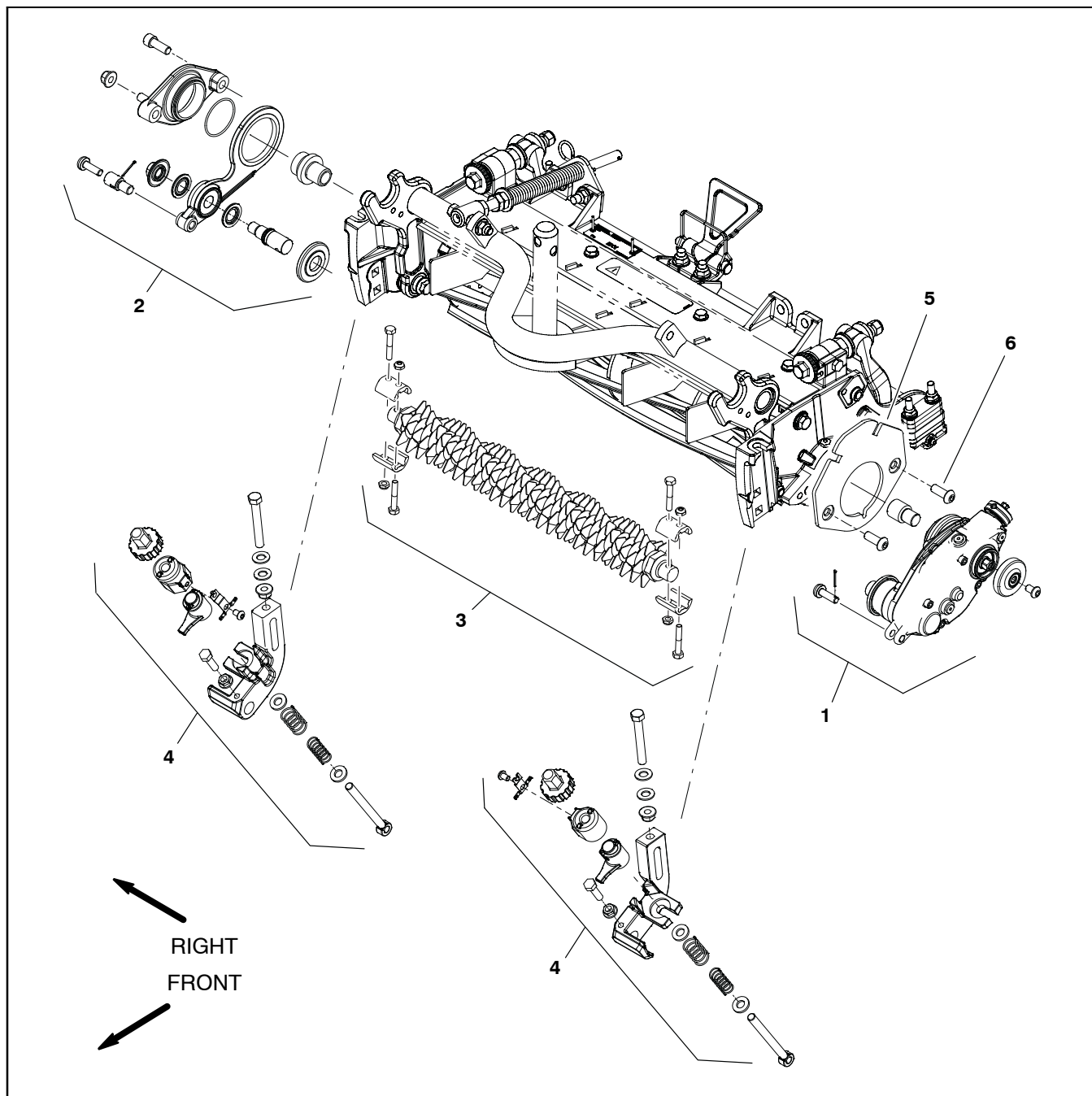

Figure 1

- | | | |
|----------------------|---------------------------------|--------------------------|
| 1. Gear box assembly | 3. Groomer reel | 5. Weight |
| 2. Idler assembly | 4. Height adjuster assembly (2) | 6. Button head screw (2) |



CAUTION

Never work on the groomer with the engine running. Always stop the engine, remove the key from the ignition switch and wait for all machine movement to stop before working on the groomer.

NOTE: The Groomer Operator's Manual provides information regarding the installation, set-up, operation and maintenance of the universal groomer on your Reelmaster machine. Refer to these instructions for additional information when servicing the groomer.

This page is intentionally left blank.

Gear Box Assembly

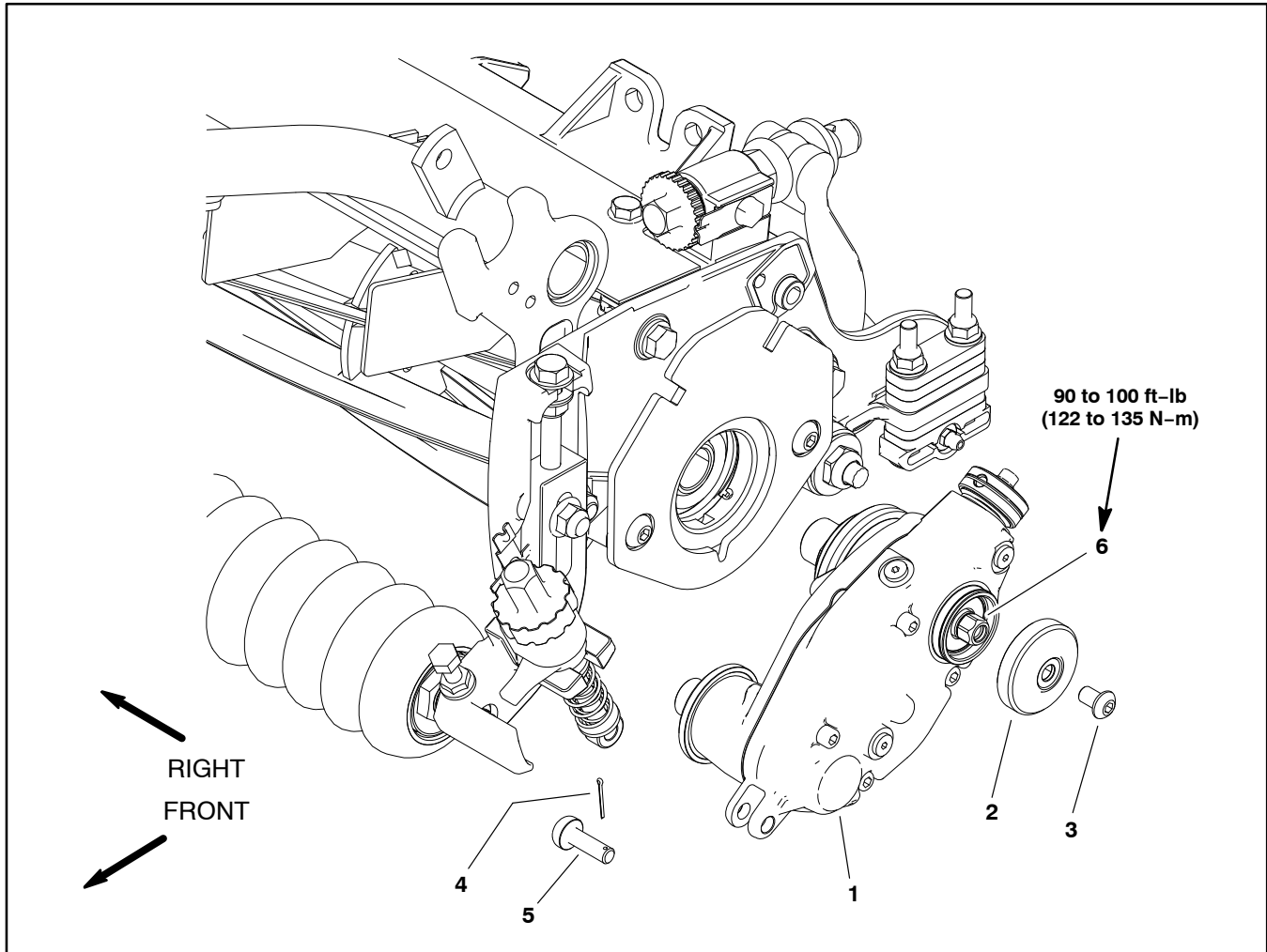

Figure 2

- | | | |
|-----------------------------------|----------------------|----------------|
| 1. Gear box assembly | 3. Button head screw | 5. Clevis pin |
| 2. Rear roller brush drive shield | 4. Cotter pin | 6. Input shaft |

NOTE: The groomer gear box assembly is located on the opposite side of the cutting unit from the cutting unit hydraulic motor.

Removal (Fig. 2)

1. Park machine on a clean and level surface, lower cutting units completely to the ground, stop engine, engage parking brake and remove key from the ignition switch.
2. Remove the groomer reel assembly (see Groomer reel in this chapter).

NOTE: If cutting unit is equipped with an optional powered rear roller brush, remove the rear roller brush cover, drive belt and drive housing assembly to service the groomer drive (see Roller Brush (Optional) in Chapter 7 – Cutting Units in this manual for additional information).



CAUTION

Contact with the reel or other cutting unit parts can result in personal injury. Use heavy gloves when handling the cutting reel.

3. Safely prevent reel from rotating by blocking the cutting reel with piece of wood near one of the reel spiders.

4. If installed, remove the rear roller brush drive shield from the gear box.

IMPORTANT: Groomer gear boxes installed on the left side of the cutting unit use a left hand thread. Turn the input shaft (rear roller brush drive shaft) clockwise to remove the gear box. Groomer gear boxes installed on the right side of the cutting unit use a right hand thread. Turn the input shaft counterclockwise to remove the gear box.

5. To detach the gear box from the cutting unit:

A. Turn the input shaft in the correct direction to loosen it from the reel.

B. Remove the cotter pin and clevis pin from the height adjustment rod at the front of the groomer gear box. Discard cotter pin.

C. Continue to unscrew the input shaft and remove the gear box from the cutting unit.

Disassembly (Fig. 3)

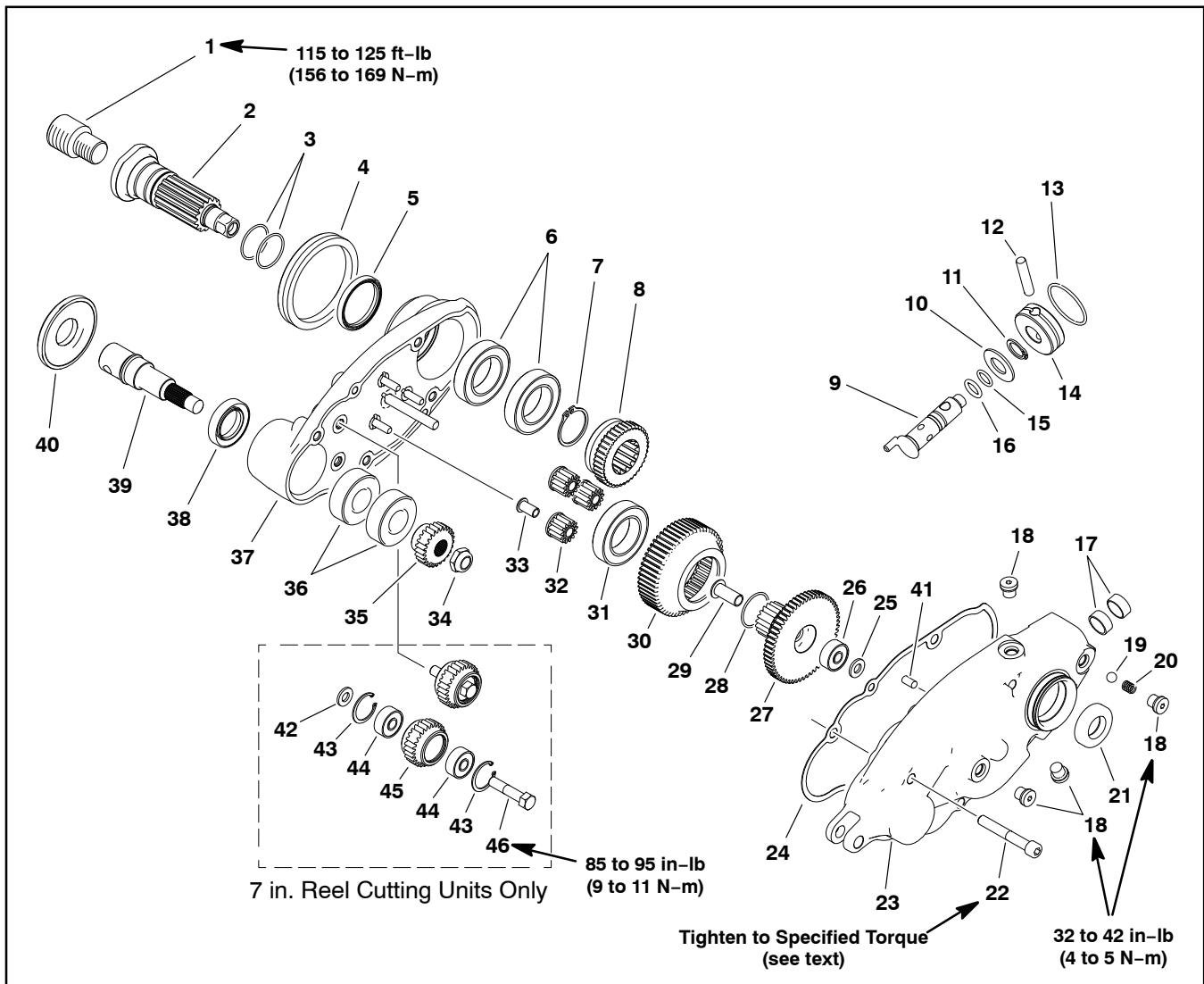

Figure 3

- | | | |
|---------------------|---------------------------|------------------------|
| 1. Threaded adapter | 17. Bushing (2) | 32. Planet gear (3) |
| 2. Input shaft | 18. Drain/fill plug (4) | 33. Bushing (3) |
| 3. O-Ring (2) | 19. Ball | 34. Lock nut |
| 4. V-Ring | 20. Detent spring | 35. Output gear |
| 5. Seal | 21. Seal | 36. Bearing (2) |
| 6. Bearing (2) | 22. Socket head screw (4) | 37. Housing |
| 7. Retaining ring | 23. Cover | 38. Seal |
| 8. Slider gear | 24. Gasket | 39. Output shaft |
| 9. Shifter shaft | 25. Thrust washer | 40. Shield |
| 10. Thrust washer | 26. Bearing | 41. Dowel pin (2) |
| 11. Retaining ring | 27. Sun gear | 42. Thrust washer (2) |
| 12. Dowel pin | 28. O-ring | 43. Retaining ring (2) |
| 13. O-ring | 29. Bushing | 44. Bearing (4) |
| 14. Knob | 30. Ring gear | 45. Idler gear (2) |
| 15. O-ring | 31. Bearing | 46. Cap screw (2) |
| 16. O-ring | | |

The gear box assemblies for cutting units with 5 in. reels and 7 in. reels are very similar. The gear box for cutting units with 7 in. reels have two (2) additional idler gear assemblies (Fig. 4).



CAUTION

Use the 1-3/8" flats on the input shaft to prevent the input shaft from rotating during adapter removal. DO NOT use the 1/2" hex on the input shaft to secure the shaft during adapter removal or input shaft damage may occur.

1. Remove input shaft adapter (item 1) if necessary.
2. Remove the drain/fill plug and drain the oil from the gear box.
3. Remove four (4) socket head cap screws (item 22) and separate the gear box cover and housing.
4. Remove and discard the cover gasket.
5. Slide the sun gear, ring gear and planet gears from the pins on the gear box housing.
6. Continue to disassemble the gear box as necessary.
7. Carefully clean any gasket material from gear box housing and cover.
8. Inspect V-ring, seals, bearings, gears and bushings in gear box assembly. Replace damaged or worn components as necessary.

Assembly (Fig. 3)

1. If sun gear, ring gear or gear box housing bearings are replaced, press bearings all the way to shoulder in part.
2. If flange bushings are replaced, ensure bushing flange is fully seated against part.
3. Ensure all retaining rings and O-rings are fully seated in ring groove.
4. Lubricate seal lips and O-rings before installing shafts.
5. If idler gear assemblies were removed (Gear box for 7 in. reel cutting units only) tighten idler gear cap screw from **85 to 95 in-lb (9 to 11 N-m)**.
6. Lubricate planet gear and sun gear pins in gear box housing with gear oil and install planet, ring and sun gears.

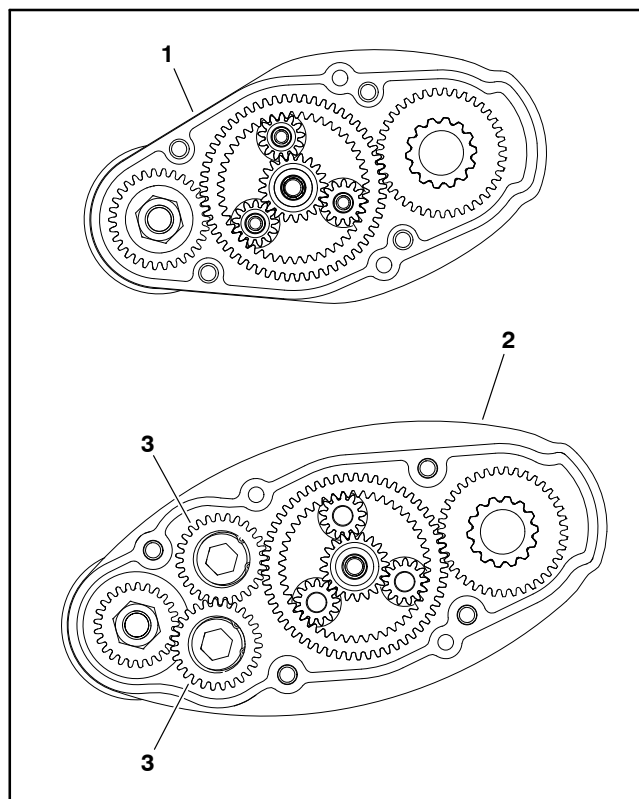

Figure 4

- | | |
|--|--|
| 1. Gear box assembly
(5 in. reel cutting units) | 2. Gear box assembly
(7 in. reel cutting units) |
| | 3. Idler gear (2) |

7. Clean gasket surface on gear box housing and cover with solvent and install new gasket.
8. Fit gear box cover over dowel pins and install four (4) socket head screws. Tighten screws from **15 to 40 in-lb (2 to 4 N-m)**. In an alternating cross pattern, tighten four (4) socket head screws from **75 to 85 in-lb (8 to 9 N-m)**.
9. Fill the gear box with 80W-90 gear oil and tighten drain/fill plug from **32 to 52 in-lb (4 to 5 N-m)**.

Gear box oil capacity for 5 in. reel cutting units = 1.7 oz. (50 cc)

Gear box oil capacity for 7 in. reel cutting units = 3 oz. (90 cc)



CAUTION

Use the 1-3/8" flats on the input shaft to prevent the input shaft from rotating during adapter installation. DO NOT use the 1/2" hex on the input shaft to secure the shaft during adapter installation or input shaft damage may occur.

10. If removed, install the threaded adapter in the input shaft. If reusing a previously installed threaded adapter, apply medium strength thread locker to the smaller (5/8-11) threads only. Tighten threaded adapter from **115-125 ft-lb (156-196 N-m)**.

11. Operate groomer gear box by hand to check for proper operation prior to installation.

Installation (Fig. 2)

1. Park machine on a clean and level surface, lower cutting units completely to the ground, stop engine, engage parking brake and remove key from the ignition switch.



CAUTION

Contact with the reel or other cutting unit parts can result in personal injury. Use heavy gloves when handling the cutting reel.

2. Safely prevent reel from rotating by blocking the cutting reel with piece of wood near one of the reel spiders.

IMPORTANT: Groomer gear boxes installed on the left side of the cutting unit use a left hand thread. Turn the input shaft (rear roller brush drive shaft) counterclockwise to install the gear box. Groomer gear boxes installed on the right side of the cutting unit use a right hand thread. Turn the input shaft clockwise to install the gear box.

3. To attach the gear box to the cutting unit:

A. Turn the input shaft in the correct direction until it is seated against the reel.

B. Use a new cotter pin and install the cotter pin and clevis pin securing the height adjustment rod to the front of the groomer gear box.

C. Tighten the input shaft from **90 to 100 ft-lb (122 to 153 N-m)**.

4. Install the rear roller brush drive shield if previously removed.

NOTE: If cutting unit is equipped with an optional powered rear roller brush, install the rear roller brush drive housing assembly, drive belt and cover (see Roller Brush (Optional) in Chapter 7 – Cutting Units in this manual for additional information).

5. Install the groomer reel assembly (see Groomer reel in this chapter).

This page is intentionally left blank.

Idler Assembly

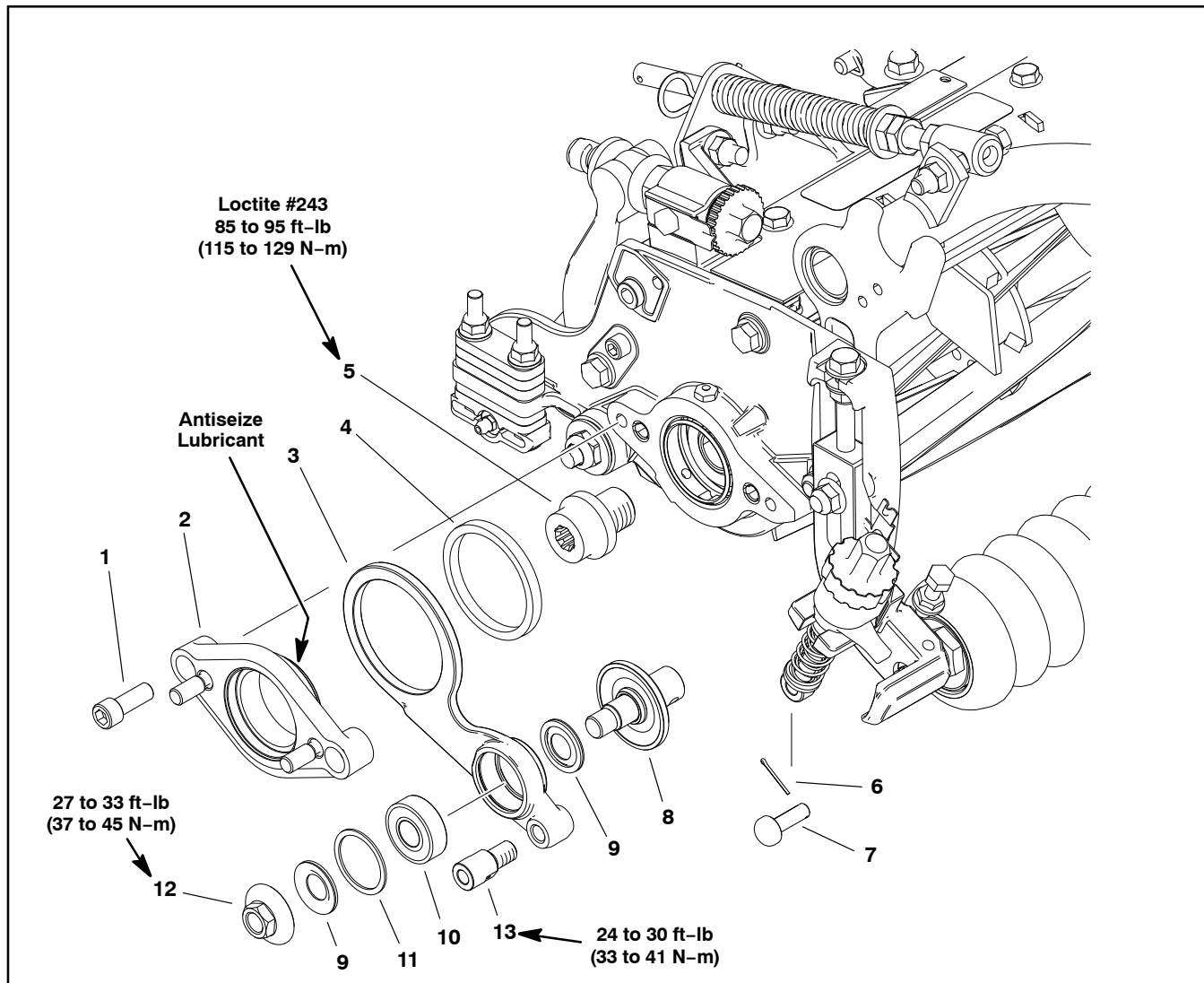

Figure 5

- | | | |
|--------------------------|--------------------------|--------------------|
| 1. Socket head screw (2) | 6. Cotter pin | 10. Bearing |
| 2. Pivot hub | 7. Clevis pin | 11. Retaining ring |
| 3. Idler arm | 8. Stub shaft and shield | 12. Flange nut |
| 4. Bushing | 9. Bearing shield (2) | 13. Collar |
| 5. Threaded insert | | |

NOTE: The groomer idler assembly is located on the same side of the cutting unit as the cutting unit hydraulic motor.

Removal (Fig. 5)

1. Park machine on a clean and level surface, lower cutting units completely to the ground, stop engine, engage parking brake and remove key from the ignition switch.

2. Remove hydraulic reel motor from cutting unit (see Hydraulic Reel Motor Removal in Chapter 7 – Cutting Units in this manual).

3. Remove the groomer reel assembly (see Groomer reel in this chapter).

4. Remove the cotter pin and clevis pin from the height adjustment rod at the front of the idler arm. Discard cotter pin.

5. Remove the socket head cap screws securing the pivot hub to the cutting unit and remove the pivot hub and idler assembly from the cutting unit.

6. Inspect shields, bearing and bushing in idler assembly. Remove and discard damaged or worn components.

Installation (Fig. 5)

1. If shields, bearing or bushing was removed from idler arm, install new components.

A. Press bushing into groomer plate until the bushing is centered in the idler arm bore.

B. Press bearing into idler arm so that bearing contact shoulder in idler arm bore and install bearing retaining ring.

C. Install bearing shields with flocked side of shield toward bearing.

D. Verify idler arm orientation (LH or RH cutting unit) and insert stub shaft through shields and bearing. Using through hole in shaft to prevent shaft from rotating, tighten flange nut from **27 to 33 ft-lb (37 to 45 N-m)**.

E. If collar was removed from idler arm, install collar and tighten from **24 to 30 ft-lb (33 to 41 N-m)**.

2. Apply antisieze lubricant to the outside diameter of the pivot hub (Fig. 6). Position idler arm over pivot hub.

3. Apply Loctite to two (2) socket head screws and secure pivot hub and idler arm to cutting unit side plate.

4. Use a new cotter pin and install the cotter pin and clevis pin securing the height adjustment rod to the front of the idler arm.

5. Install hydraulic reel motor to cutting unit (see Hydraulic Reel Motor Installation in Chapter 7 – Cutting Units in this manual).

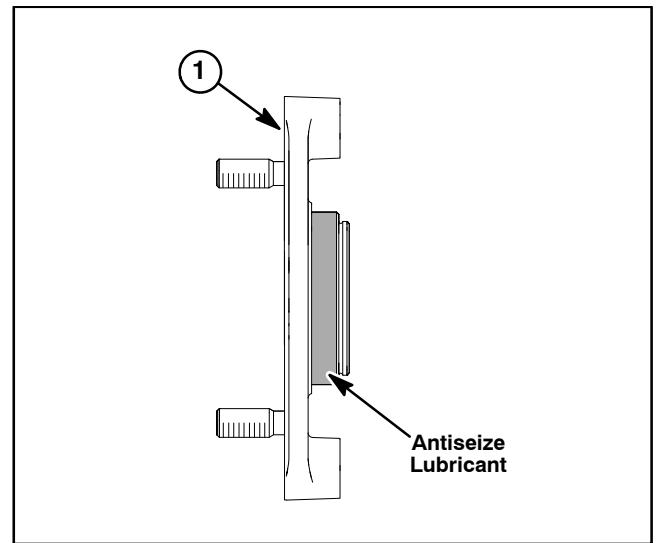

Figure 6

1. Pivot hub

Groomer Reel

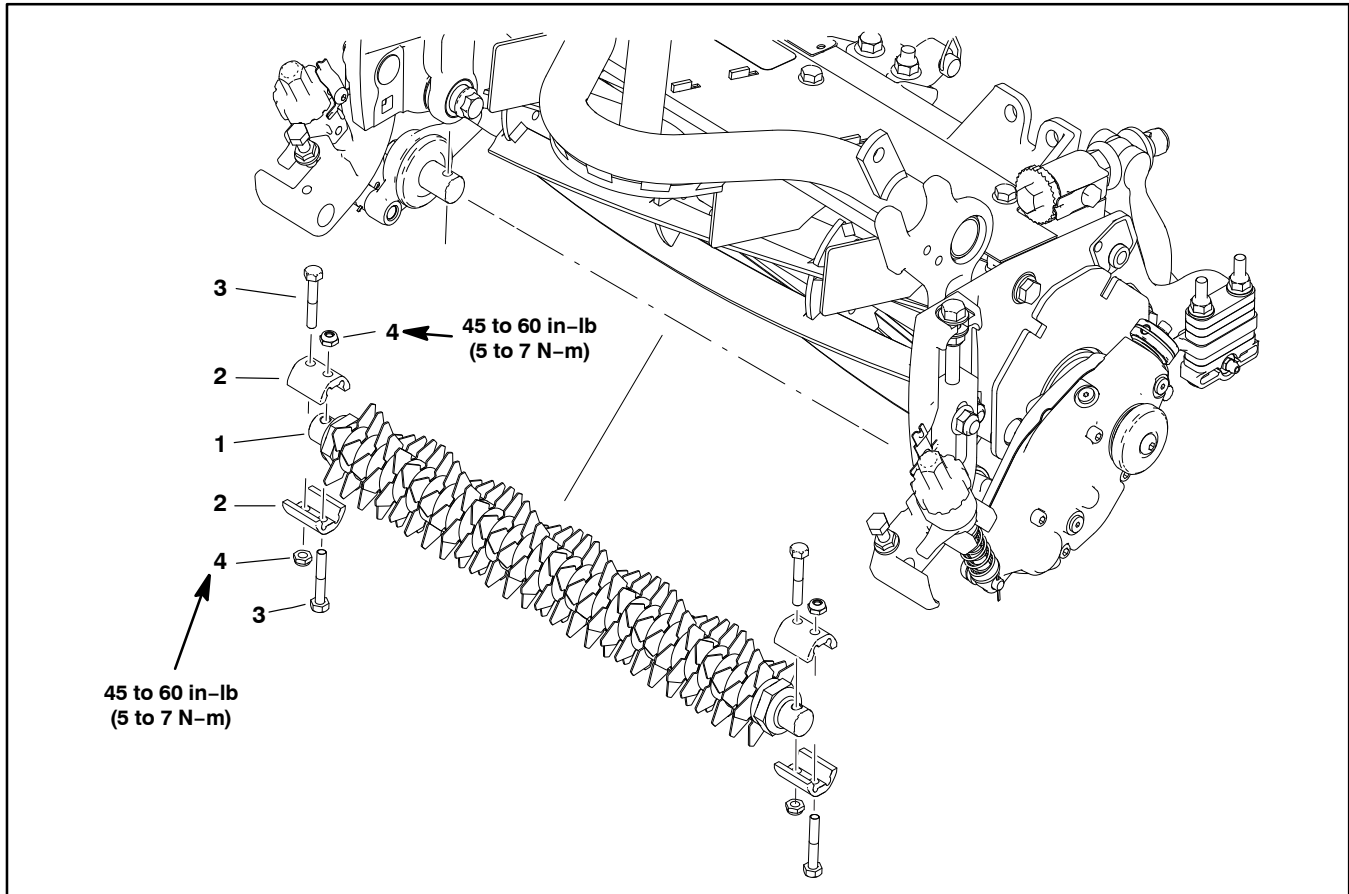

Figure 7

1. Groomer reel
2. Shaft clamp (4)

3. Cap screw (4)

4. Jam nut (4)

Remove the groomer reel to replace individual groomer blades or replace the shaft. The groomer reel can be reversed to provide additional blade life.

Removal (Fig. 7)

1. Park machine on a clean and level surface, lower cutting units completely to the ground, stop engine, engage parking brake and remove key from the ignition switch. If desired, remove cutting unit from machine (see Traction Unit Operator's Manual).



CAUTION

Contact with the reel or other cutting unit parts can result in personal injury. Use heavy gloves when handling the groomer reel.

2. Carefully remove the four (4) jam nuts, cap screws and shaft clamps securing the groomer reel to the output and stub shafts.

3. Lift the groomer reel from the cutting unit.

4. Inspect seal, shields, bushing and bearings for wear or damage. Replace components as needed (see Gear Box Assembly and Idler Assembly in this section).

Installation (Fig. 7)

1. Position cutting unit on a level surface. If cutting unit is attached to traction unit, make sure to stop engine, engage parking brake and remove key from the ignition switch.

2. Position the groomer reel between the groomer output and stub shafts.

3. Secure the groomer reel to the cutting unit with four (4) jam nuts, cap screws and shaft clamps. Tighten the cap screws to **46 to 60 in-lb (5 to 7 N-m)**.

4. Check groomer reel height and mower height-of-cut settings. Adjust as needed.

Groomer Reel Service

Inspect groomer reel blades frequently for damage and wear. Straighten bent blades. Either replace worn blades or reverse the individual blades to put the sharpest blade edge forward (Fig. 8). Blades that are rounded to the midpoint of the blade tip must be reversed or replaced for best groomer performance.

Disassembly (Fig. 9)

1. Park machine on a clean and level surface, lower cutting units completely to the ground, stop engine, engage parking brake and remove key from the ignition switch.
2. Remove groomer reel from cutting unit (see Groomer Reel Removal in this section).
3. If groomer reel is equipped with broomer kit, remove straps and broomer brushes from reel (Fig. 12).
4. Remove lock nut from either end of the shaft (Fig. 9).
5. Remove spacers and blades from groomer shaft. If needed, remove second lock nut from shaft.

Assembly (Fig. 9)

1. Install lock nut on drive end of groomer shaft. Place a 1/4" (6.3 mm) spacer on the groomer shaft followed by the first groomer blade.
2. Alternately install 1-1/4" (31.7 mm) spacers and blades making sure that all blades are separated by a spacer.
3. When all blades have been installed, place remaining 1/4" (6.3 mm) on shaft. Thread second lock nut onto the shaft. Center blades on shaft by adjusting lock nuts.
4. Using through holes in shaft to prevent shaft from rotating, tighten second lock nut from **31 to 35 in-lb (42 to 48 N-m)**. After tightening lock nut, spacers should not be free to rotate and groomer blades should be centered on shaft.

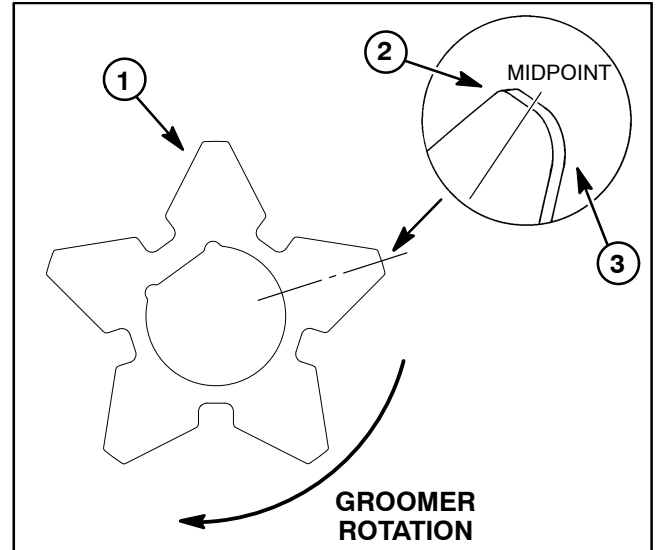

Figure 8

- | | |
|------------------|------------------------|
| 1. Groomer blade | 3. Dull (rounded) edge |
| 2. Sharp edge | |

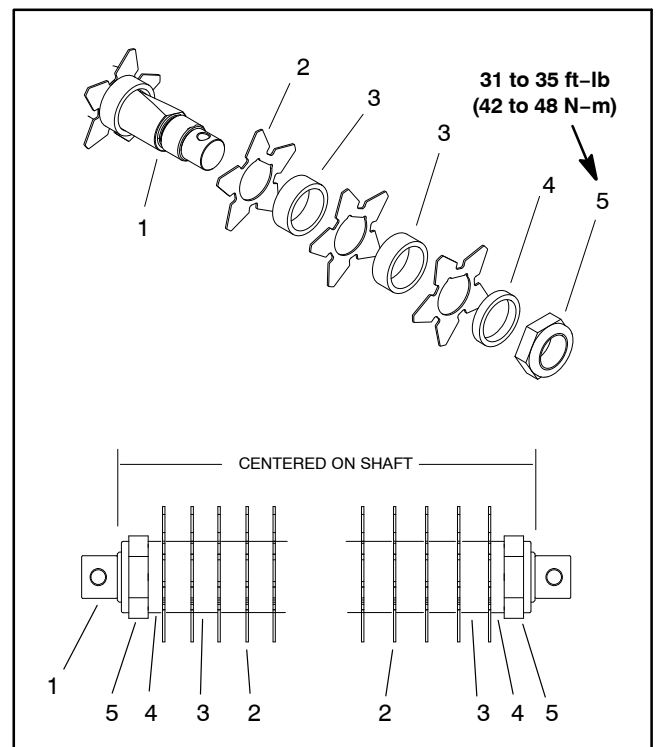

Figure 9

- | | |
|-----------------------|-----------------------------|
| 1. Groomer reel shaft | 3. 1-1/4" (31.7 mm) Spacer |
| 2. Groomer blade | (18 in. reel = 31) |
| (18 in. Reel = 32) | (22 in. Reel = 39) |
| (11 in. Reel = 40) | 4. 1/4" (6.3 mm) Spacer (2) |
| | 5. Lock nut (2) |

5. If groomer reel is equipped with broomer kit:

A. Loosen the groomer blade retaining nuts on each end of the groomer shaft.

B. Slide a brush into each groove around the full length of the groomer reel (Fig. 10). Make sure brushes are seated in groomer blade slots (Fig. 11)

IMPORTANT: The straps must be wrapped around the groomer blade and brush assembly in the correct direction.

C. Loosely wrap the straps around the groomer reel shaft and brushes as shown (Fig. 10). Straps should be positioned in the pre-cut notches of each brush and at the following locations on the broomer shaft:

18" reels – between blades 2–3, 11–12, 21–22 and 30–31.

22" reels – between blades 2–3, 14–15, 26–27 and 38–39.

Position the broomer brushes properly in the blade slots, and tighten the groomer blade-retaining nuts from **31 to 35 ft-lb (42 to 48 N-m)**.

D. While holding strap buckle in place, pull straps tight into the pre-cut notches of each brush.

E. Cut off strap extension approximately 1/4" (6 mm) beyond retainer and fold the excess strap over the buckle (Fig. 12).

6. Install O-ring on non-drive end of groomer shaft.

7. Install groomer reel back on cutting unit (see Groomer Reel Installation in this section).

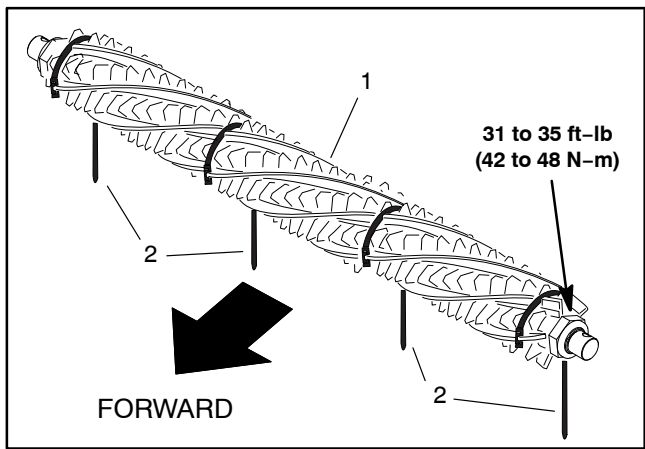

Figure 10

1. Groomer reel 2. Broomer strap (4)

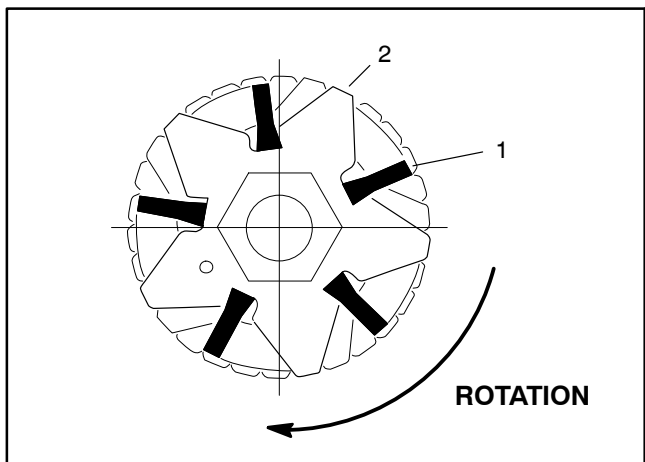

Figure 11

1. Brush 2. Blade

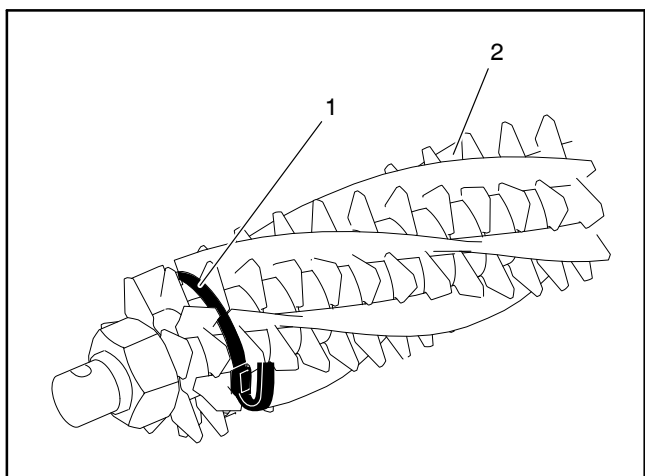

Figure 12

1. Strap 2. Brush

Grooming Brush (Optional) Service

The optional grooming brush is removed and installed from the groomer in the same manner as the groomer reel (see Groomer Reel in this chapter).

The grooming brush element or shaft can be serviced separately (Fig. 13).

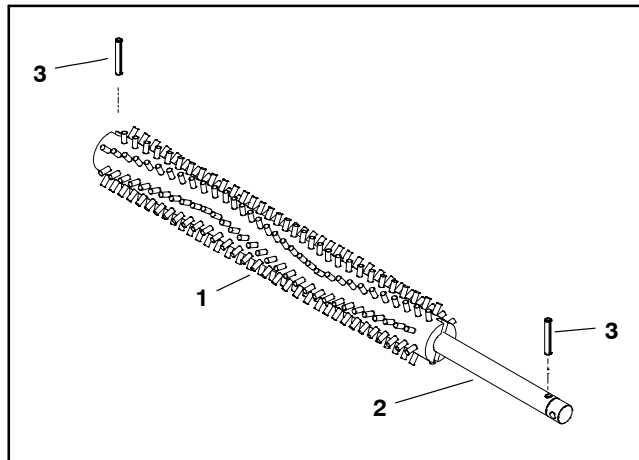

Figure 13

- 1. Brush element
- 2. Shaft
- 3. Roll pin (2)

Height Adjuster Assembly

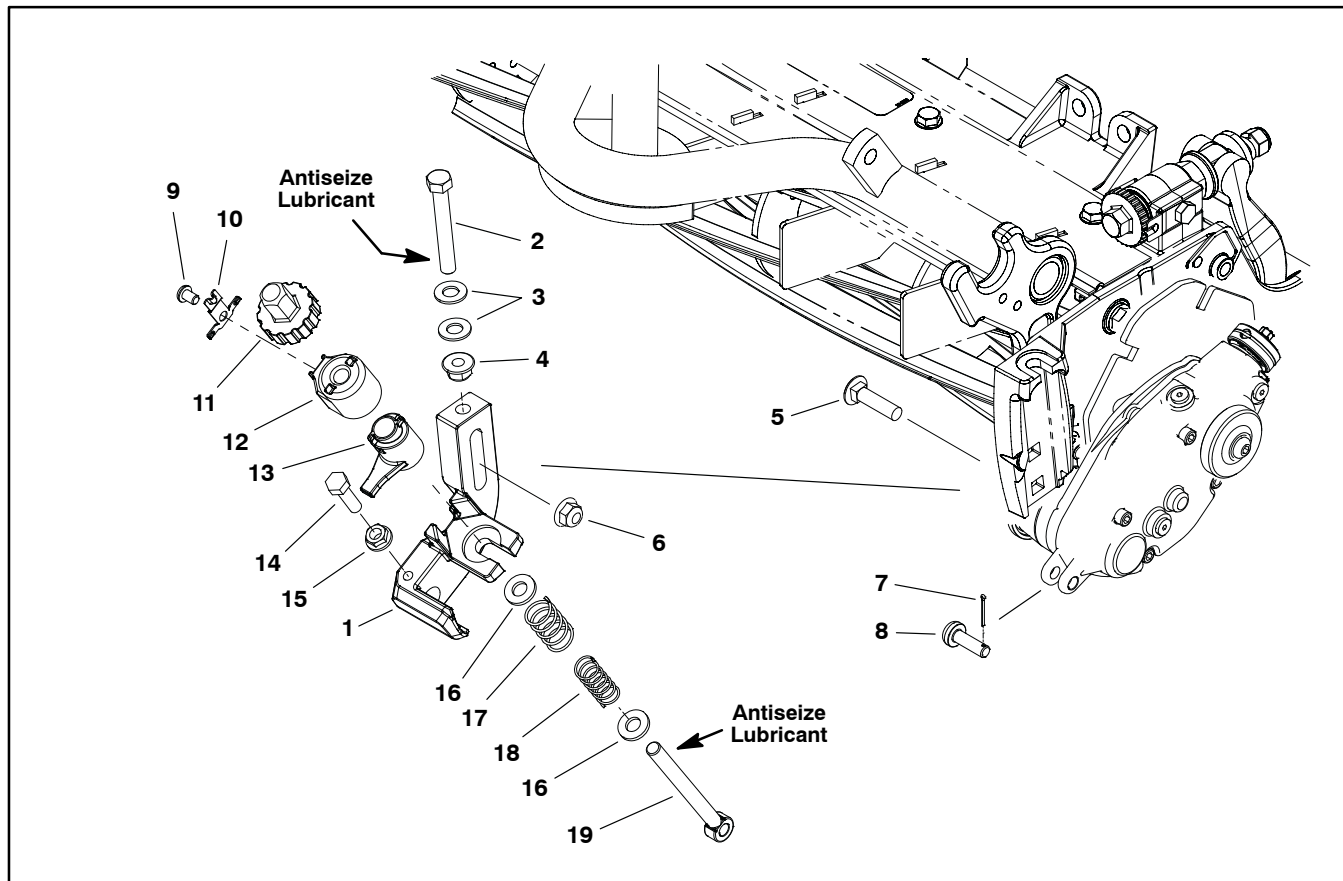

Figure 14

- | | | |
|---------------------------|----------------------------------|-------------------------------|
| 1. Height of cut bracket | 8. Clevis pin | 14. Pinch bolt (front roller) |
| 2. Height adjustment bolt | 9. Button head screw | 15. Lock nut |
| 3. Washer (2) | 10. Detent spring | 16. Washer (2) |
| 4. Lock nut | 11. Groomer height adjuster knob | 17. Outer spring |
| 5. Carriage bolt | 12. Quick up cover | 18. Inner spring |
| 6. Flange nut | 13. Quick up lever | 19. Height adjustment rod |
| 7. Cotter pin | | |

Disassembly (Fig. 14)

1. Park machine on a clean and level surface, lower cutting units completely to the ground, stop engine, engage parking brake and remove key from the ignition switch.
2. Remove the cotter pins and clevis pins securing the height adjustment rods to the groomer gear box and idler arm. Discard cotter pins.
3. Loosen the two (2) height adjustment bolt lock nuts.
4. Loosen the two (2) front roller pinch bolt lock nuts and cap screws.
5. Remove the flange nut and carriage bolt securing the height adjuster assembly to the cutting unit side plate and remove the front roller and height adjuster from the cutting unit.
6. Disassemble height adjuster assembly.
7. Clean all components and inspect for wear or damage. Replace all worn or damaged components.

Assembly (Fig. 14)

1. Apply antiseize lubricant to upper threads of adjustment rod and lower threads of height adjusters. Assemble height adjuster assembly as shown.
2. If both height adjusters were removed, fit one height adjuster assembly to the cutting unit side plate and secure with carriage bolt and flange nut. Do Not tighten the flange nut at this time. Ensure the height adjustment bolt and one (1) washer is above slot in side plate and one (1) washer and lock nut is below slot in side plate.
3. Position front roller between height adjuster assemblies and secure height adjuster assembly to cutting unit side plate with carriage bolt and flange nut. Do Not tighten the flange nut at this time. Ensure the height adjustment bolt and one (1) washer is above slot in side plate and one (1) washer and lock nut is below slot in side plate.
4. Use new cotter pins and install the cotter pins and clevis pins securing the height adjustment rods to the groomer gear box and idler arm.
5. Adjust the cutting unit height of cut (see Cutting Unit Operators Manual).
6. Check groomer reel height and adjust as needed.

This page is intentionally left blank.



Table of Contents

ELECTRICAL DRAWING DESIGNATIONS 2

HYDRAULIC SCHEMATICS

 Reelmaster 5210 and 5410 3

 Reelmaster 5510 and 5610 4

ELECTRICAL SCHEMATICS

 Reelmaster 5010 Series (Serial Number
 Below 310000000) 5

 Reelmaster 5010 Series (Serial Number
 Above 310000000) 6

ELECTRICAL CIRCUIT DIAGRAMS

 Glow Plug Circuits 7

 Crank Circuits 8

 Run (Transport) Circuits 9

 Run (Mow) Circuits 10

WIRE HARNESS DRAWINGS

 Main Wire Harness Drawing (Serial Number
 Below 310000000) 12

 Main Wire Harness Diagram (Serial Number
 Below 310000000) 13

 Main Wire Harness Drawing (Serial Number
 Above 310000000) 14

 Main Wire Harness Diagram (Serial Number
 Above 310000000) 15

 Seat Wire Harness Drawing (Serial Number
 Below 310000000) 16

 Seat Wire Harness Diagram (Serial Number
 Below 310000000) 17

 Seat Wire Harness Drawing (Serial Number
 Above 310000000) 18

 Seat Wire Harness Diagram (Serial Number
 Above 310000000) 19

 Engine Wire Harness Drawing 20

 Engine Wire Harness Diagram 21

TURF DEFENDER™ (OPTIONAL) ELECTRICAL
SCHEMATIC 22

Electrical Drawing Designations

NOTE: A splice used in a wire harness will be identified on the wire harness diagram by SP. The manufacturing number of the splice is also identified on the wire harness diagram (e.g. SP01 is splice number 1).

Wire Color

The following abbreviations are used for wire harness colors on the electrical schematics and wire harness drawings in this chapter.

<u>ABBREVIATION</u>	<u>COLOR</u>
BK	BLACK
BR or BN	BROWN
BU	BLUE
GN	GREEN
GY	GRAY
OR	ORANGE
PK	PINK
R or RD	RED
T	TAN
VIO	VIOLET
W or WH	WHITE
Y or YE	YELLOW

Numerous harness wires used on Toro machines include a line with an alternate color. These wires are identified with the wire color and line color with either a / or _ separating the color abbreviations listed above (e.g. R/BK is a red wire with a black line, OR_BK is an orange wire with a black line).

Wire Size

The individual wires of the electrical harness diagrams in this chapter identify both the wire color and the wire size.

Examples:

16 BK = 16 AWG (American Wire Gauge) wire that has a black insulator

050 R = 0.5 mm metric wire that has a red insulator (AWG equivalents for metric wire appear in the following table)

AWG EQUIVALENTS FOR METRIC WIRE		
DIAGRAM LABEL	METRIC SIZE	AWG EQUIVALENT
050	0.5 mm	20 GA
175	0.75 mm	18 GA
100	1.0 mm	16 GA
150	1.5 mm	14 GA

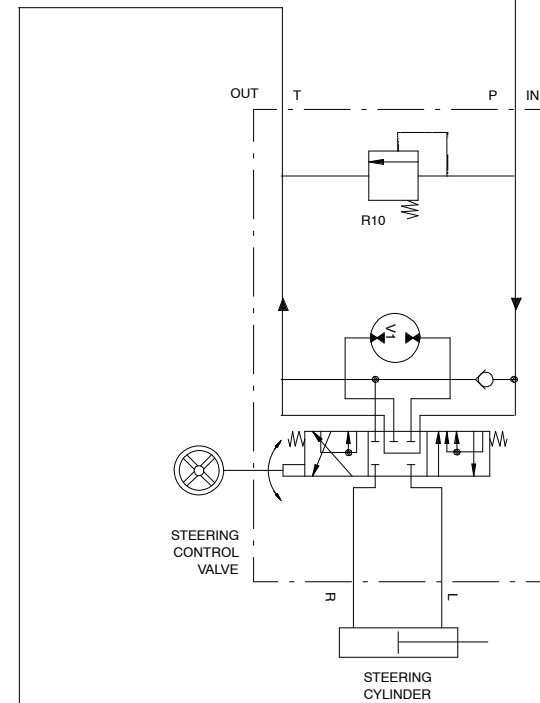
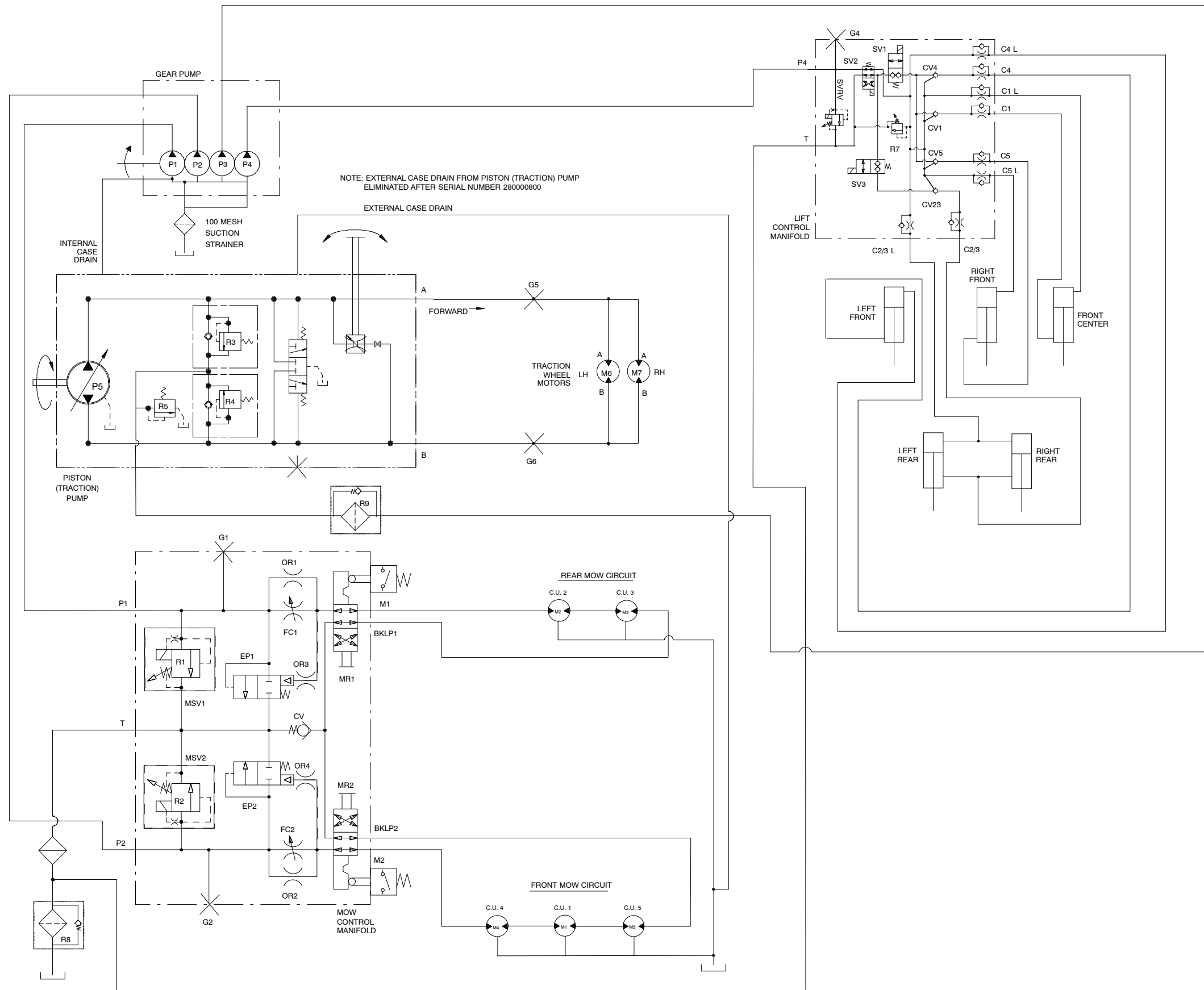

DISPLACEMENT, FLOW RATE, AND PRESSURE CHART

COMPONENT	DISPLACEMENT		PRESSURE		FLOW RATE *	
	in ³ /rev	cm ³ /rev	lbs/in ²	BARS	GPM	LPM
P1	.50	8.25			6.4	24.2
P2	.50	8.25			6.4	24.2
P3	.37	6.1			4.7	17.8
P4	.24	3.9			3.0	11.4
P5	2.14	35			27.2	103
M1	.73	12				
M2	.73	12				
M3	.73	12				
M4	.73	12				
M5	.73	12				
M6 (RM5210)	22.0	360				
M6 (RM5410)	24.7	405				
M7 (RM5210)	22.0	360				
M7 (RM5410)	24.7	405				
V1	6.1	100				
R1			2500	172		
R2			3500	241		
R3			3625	250		
R4			3625	250		
R5			200	14		
SVRV			2000	138		
R7			500	35		
R8			50	3.4		
R9			50	3.4		
R10			1000	70		

Reelmaster 5210 and 5410 Hydraulic Schematic

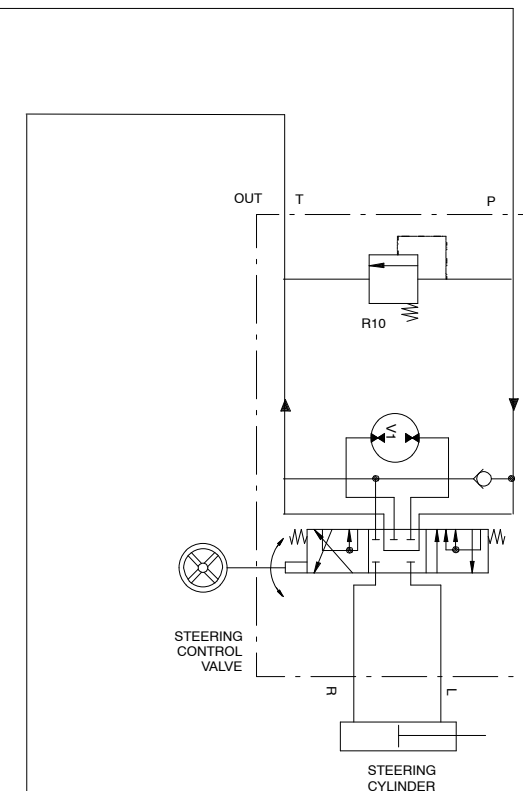
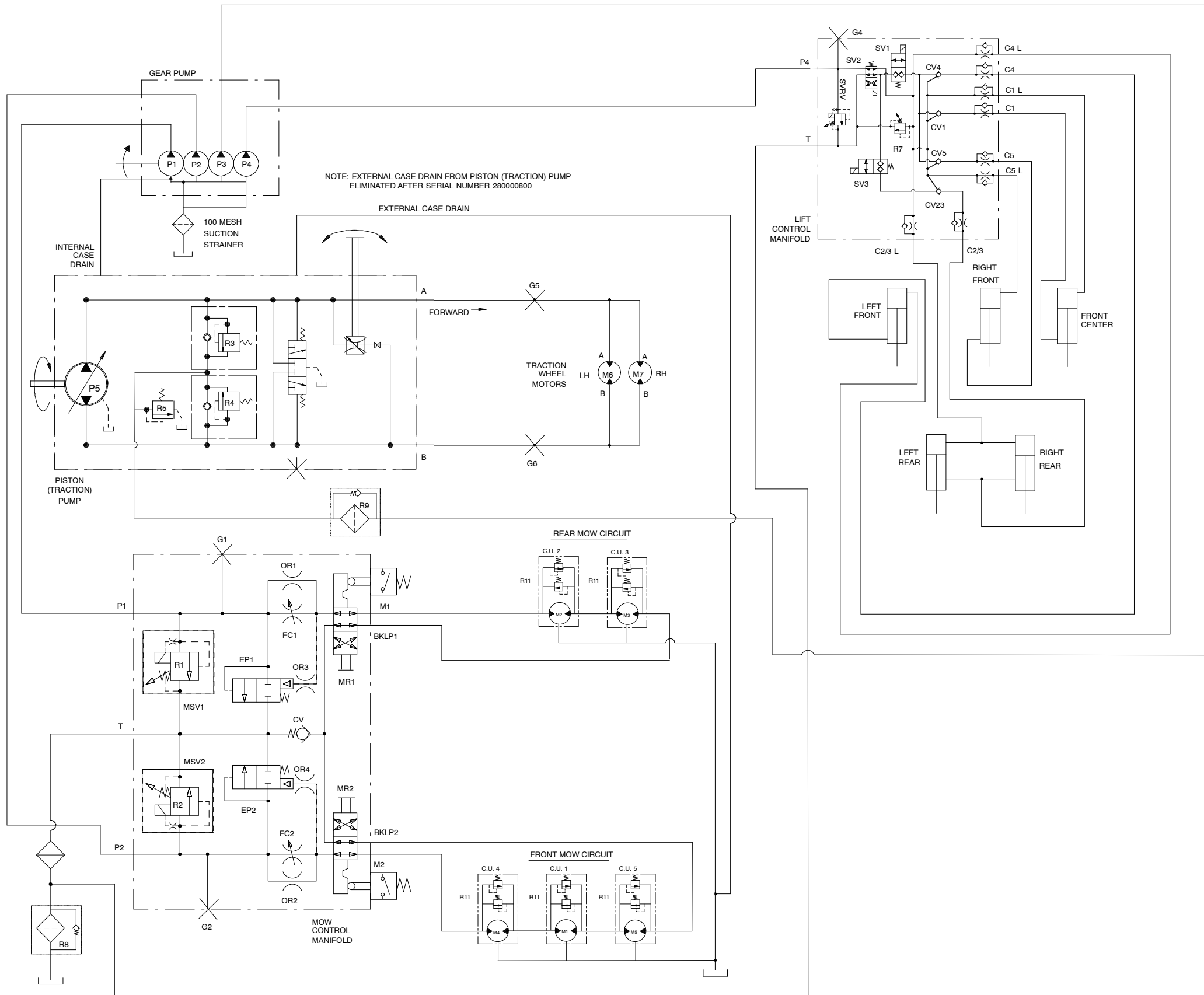

DISPLACEMENT, FLOW RATE, AND PRESSURE CHART

COMPONENT	DISPLACEMENT		PRESSURE		FLOW RATE *	
	in ³ /rev	cm ³ /rev	lbs/in ²	BARS	GPM	LPM
P1	.66	10.8			8.4	31.8
P2	.66	10.8			8.4	31.8
P3	.37	6.1			4.7	17.8
P4	.24	3.9			3.0	11.4
P5	2.14	35			27.2	103
M1	1.18	19.3				
M2	1.18	19.3				
M3	1.18	19.3				
M4	1.18	19.3				
M5	1.18	19.3				
M6	24.7	405				
M7	24.7	405				
V1	6.1	100				
R1			2500	172		
R2			3500	241		
R3			3625	250		
R4			3625	250		
R5			200	14		
SVRV			2000	138		
R7			500	35		
R8			50	3.4		
R9			50	3.4		
R10			1000	70		
R11			1500	103		

Reelmaster 5510 and 5610
Hydraulic Schematic

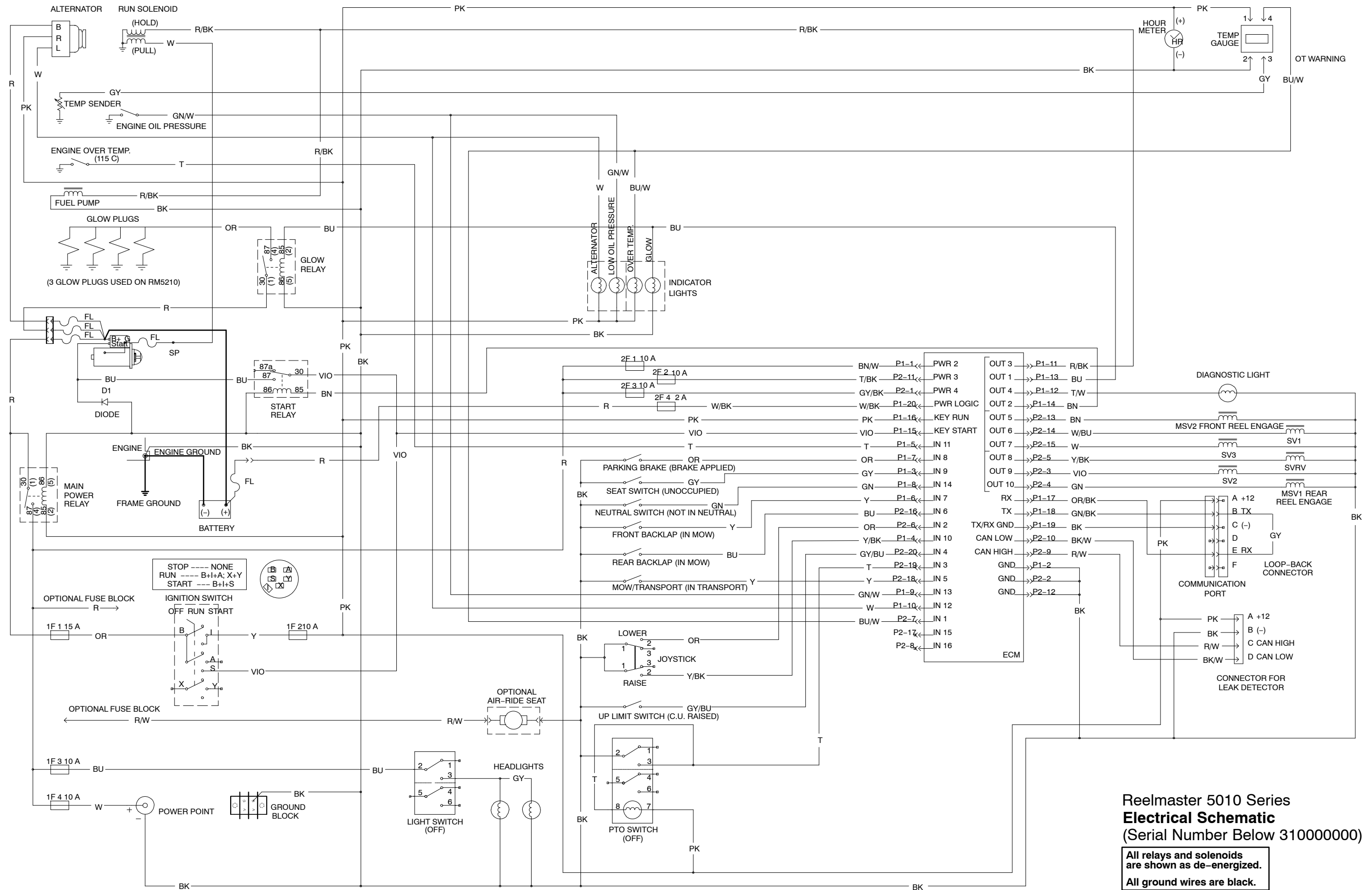

Reelmaster 5010 Series
Electrical Schematic
 (Serial Number Below 31000000)
 All relays and solenoids
 are shown as de-energized.
 All ground wires are black.

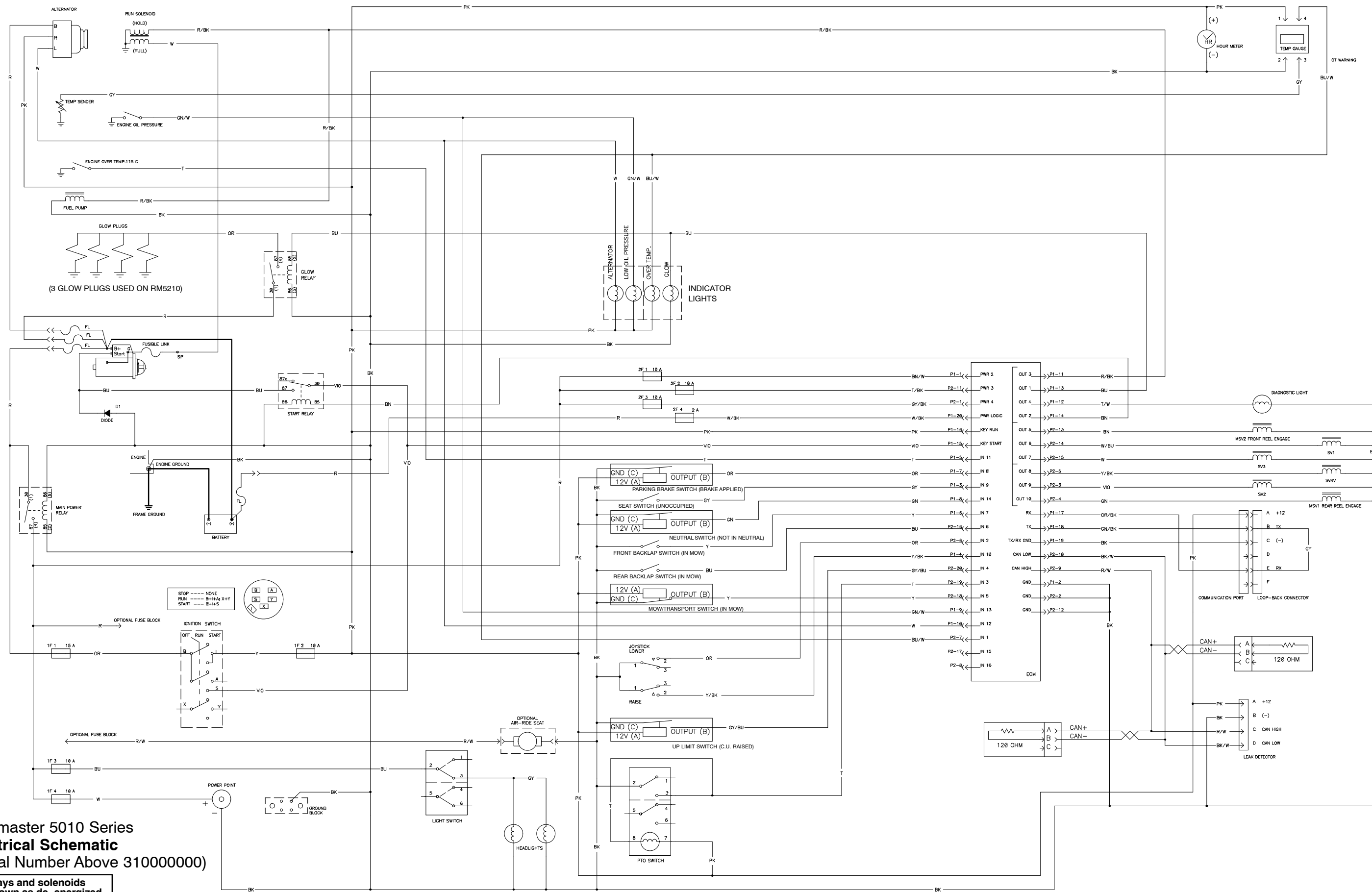

**Reelmaster 5010 Series
Electrical Schematic**
(Serial Number Above 31000000)

All relays and solenoids are shown as de-energized.
All ground wires are black.

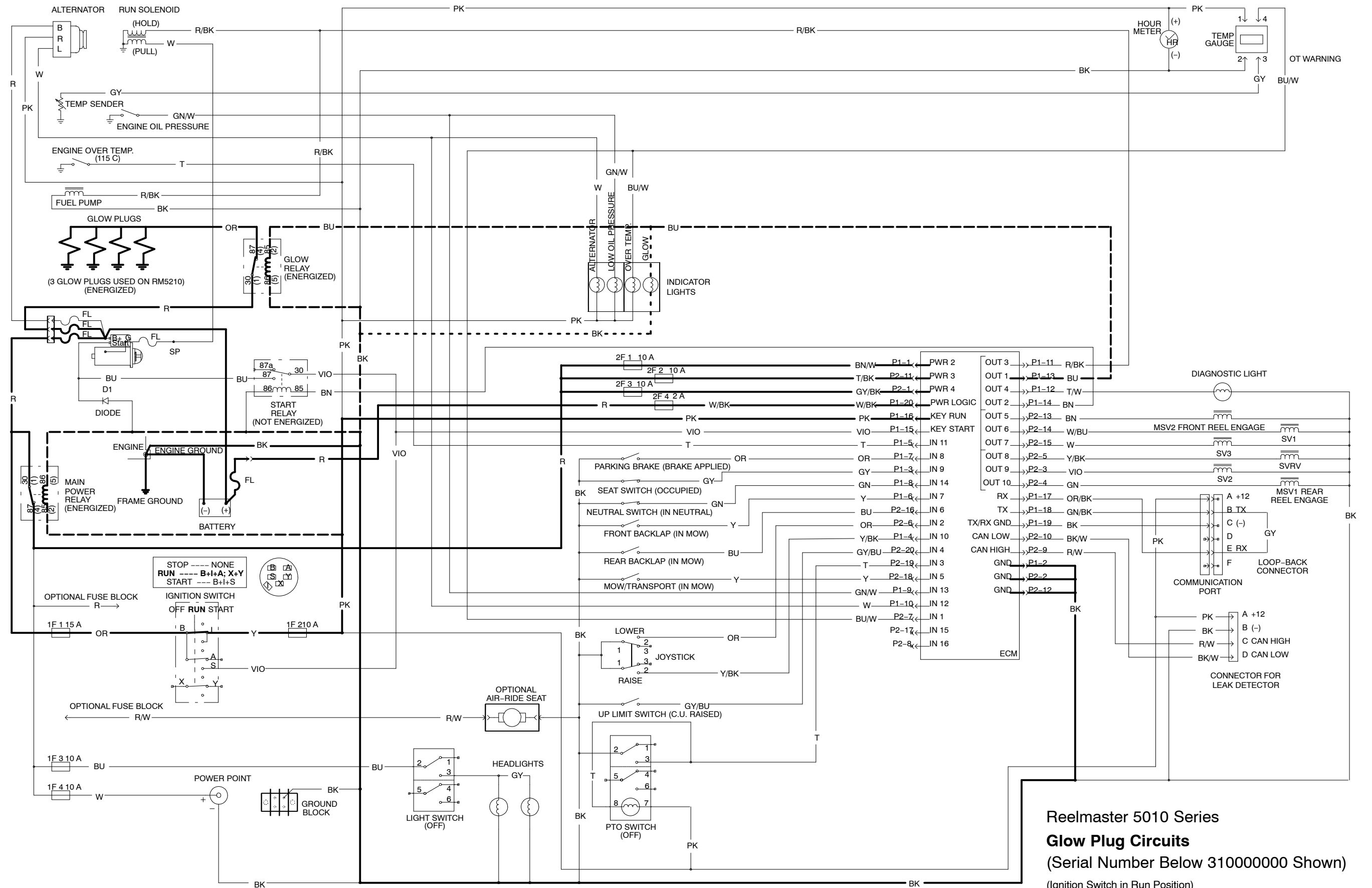

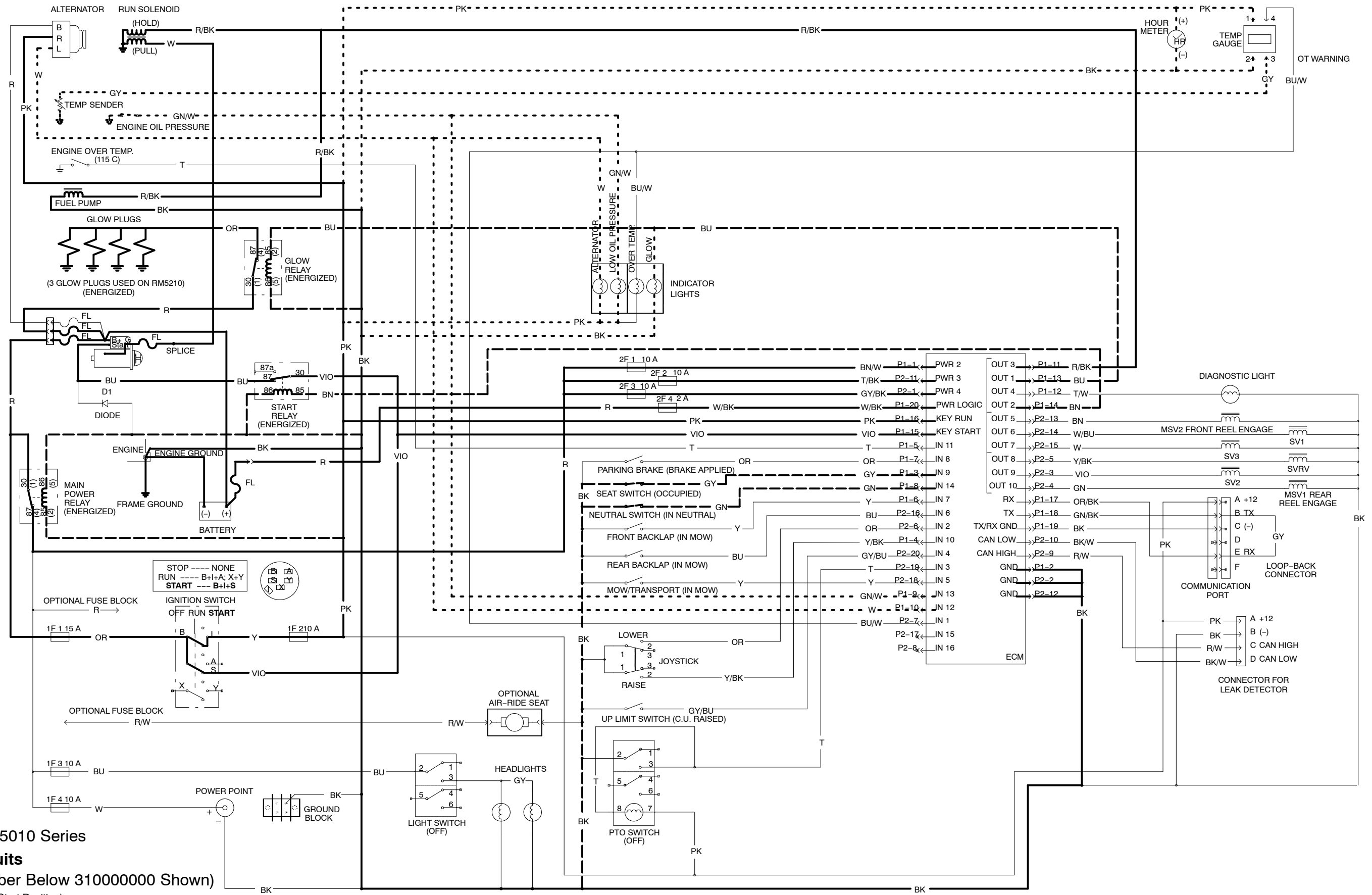

**Reelmaster 5010 Series
Crank Circuits**
(Serial Number Below 310000000 Shown)

(Ignition Switch in Start Position)

- Power Current
- - - Control Current
- Indicator/Gauge Current

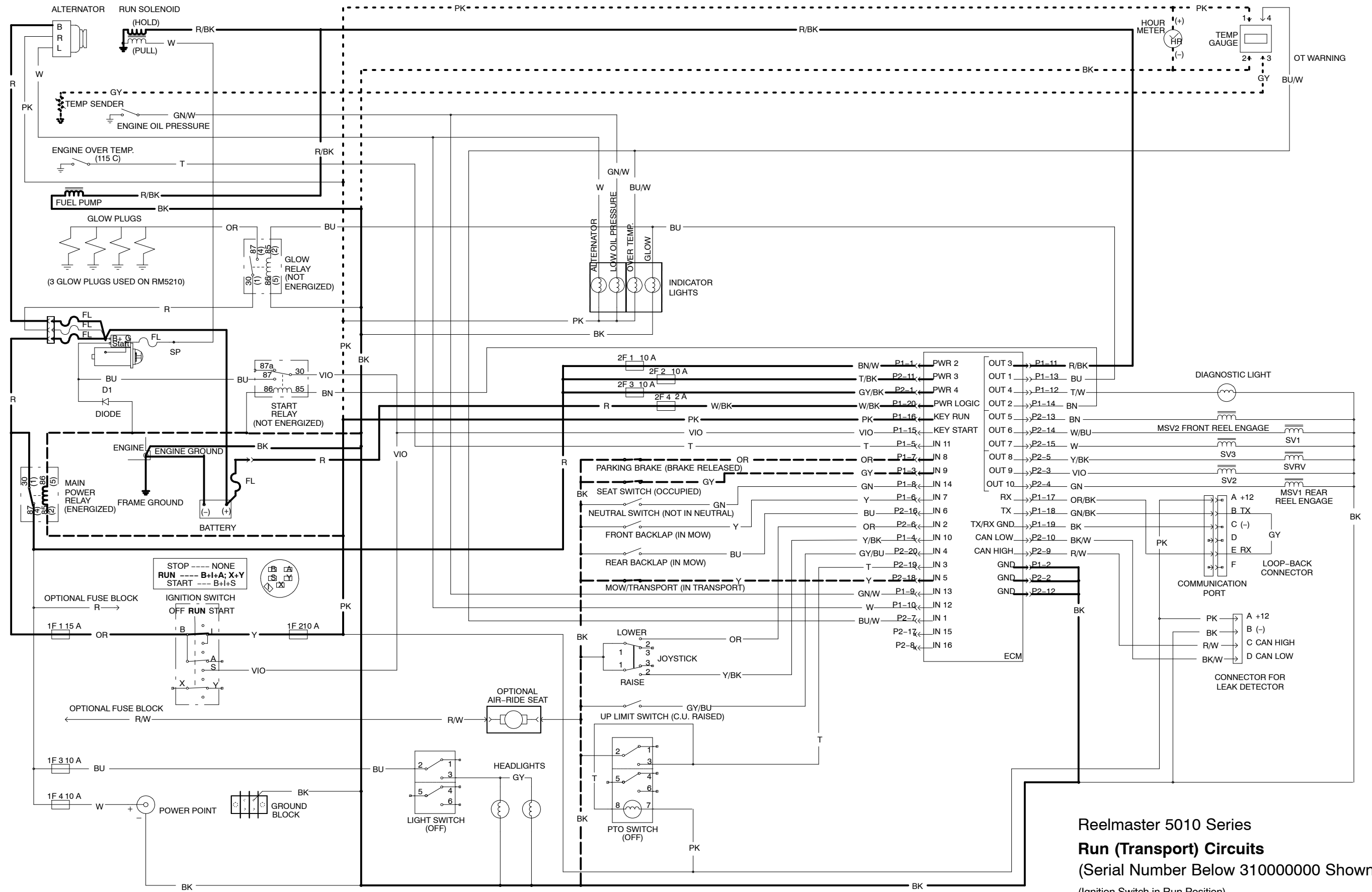

**Reelmaster 5010 Series
Run (Transport) Circuits
(Serial Number Below 31000000 Shown)**

(Ignition Switch in Run Position)

- Power Current
- - - Control Current
- · · · · Indicator/Gauge Current

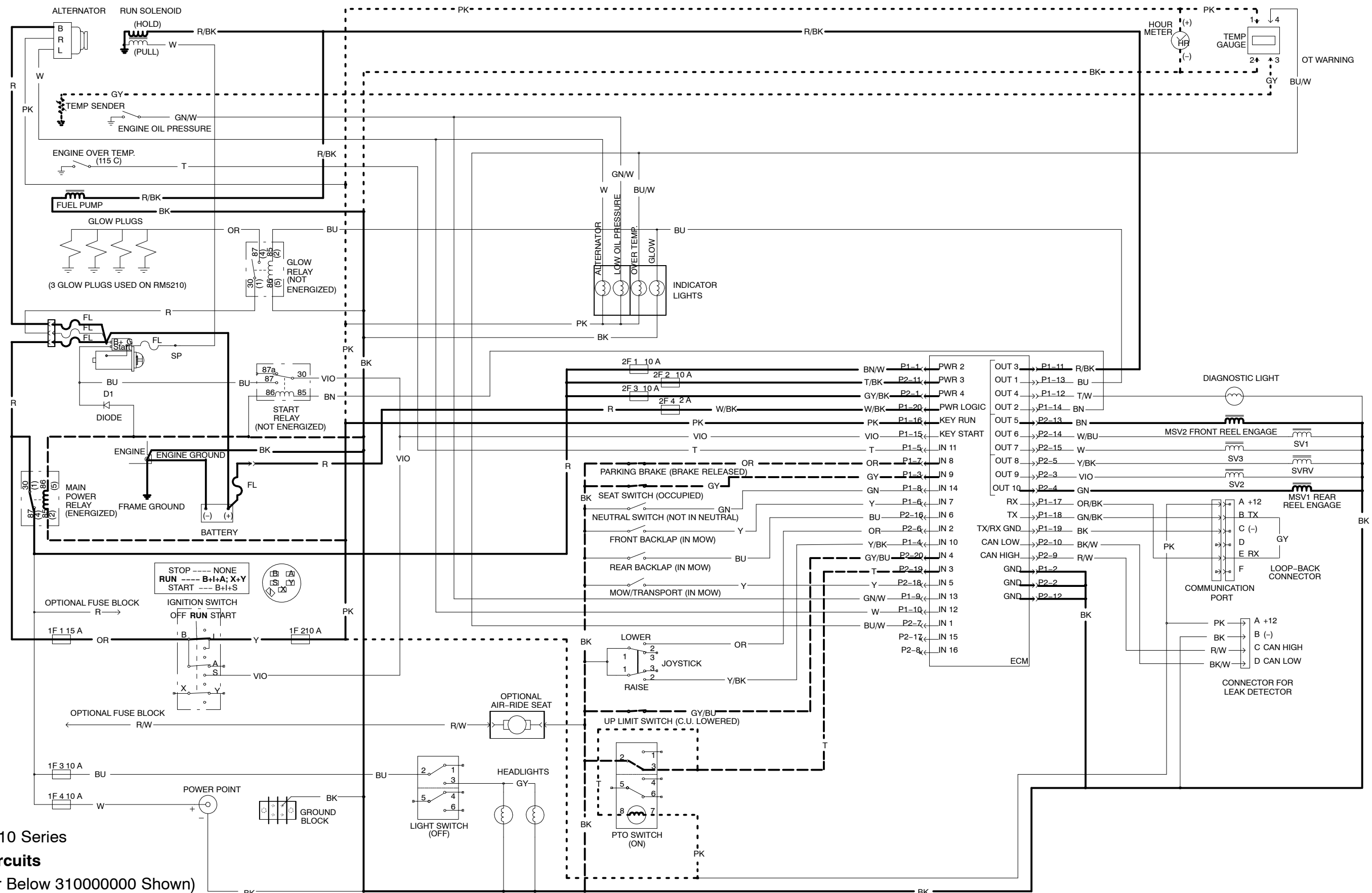

Reelmaster 5010 Series
Run (Mow) Circuits
 (Serial Number Below 310000000 Shown)

- (Ignition Switch in Run Position)
- Power Current
 - - - - - Control Current
 - Indicator/Gauge Current

This page is intentionally blank.

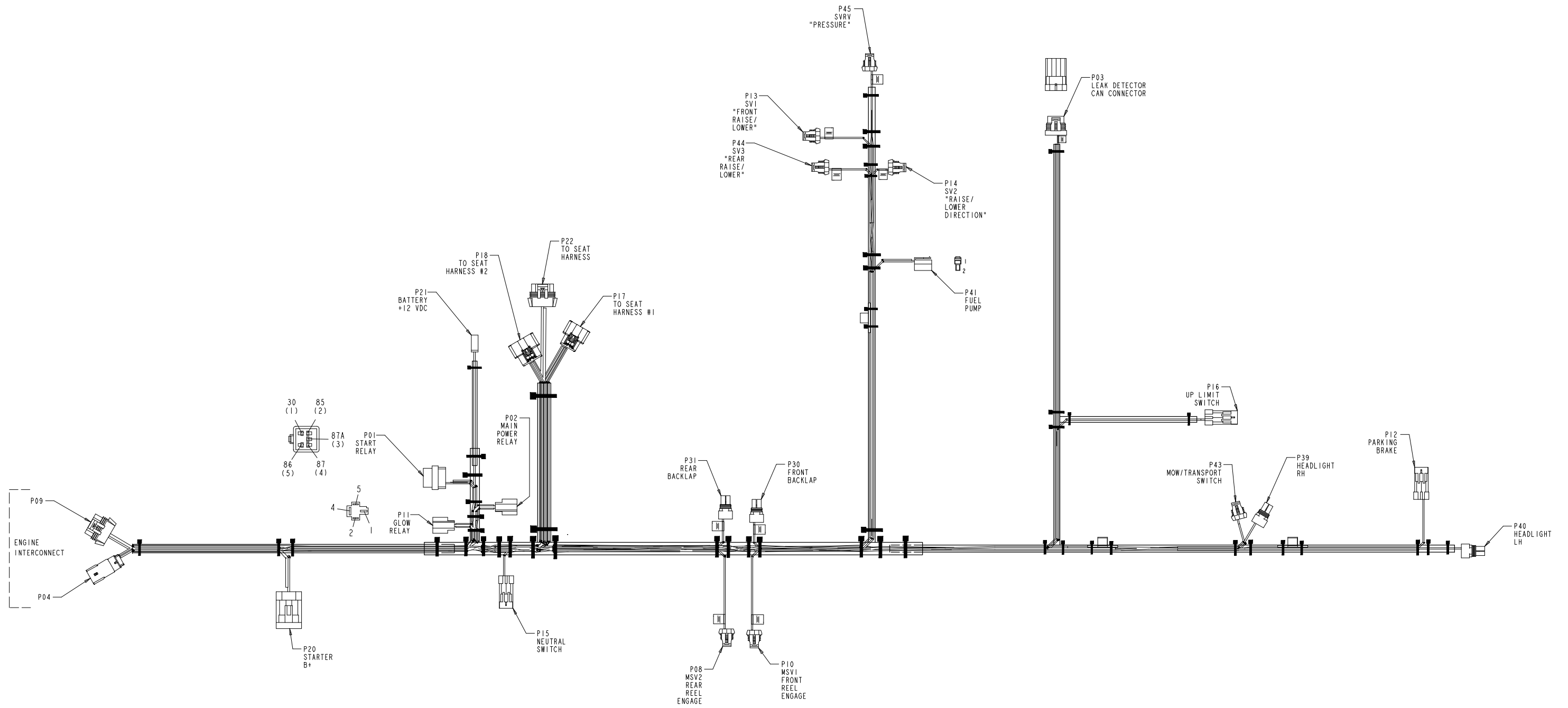

Reelmaster 5010 Series
Main Wire Harness Drawing
 (Serial Number Below 310000000)

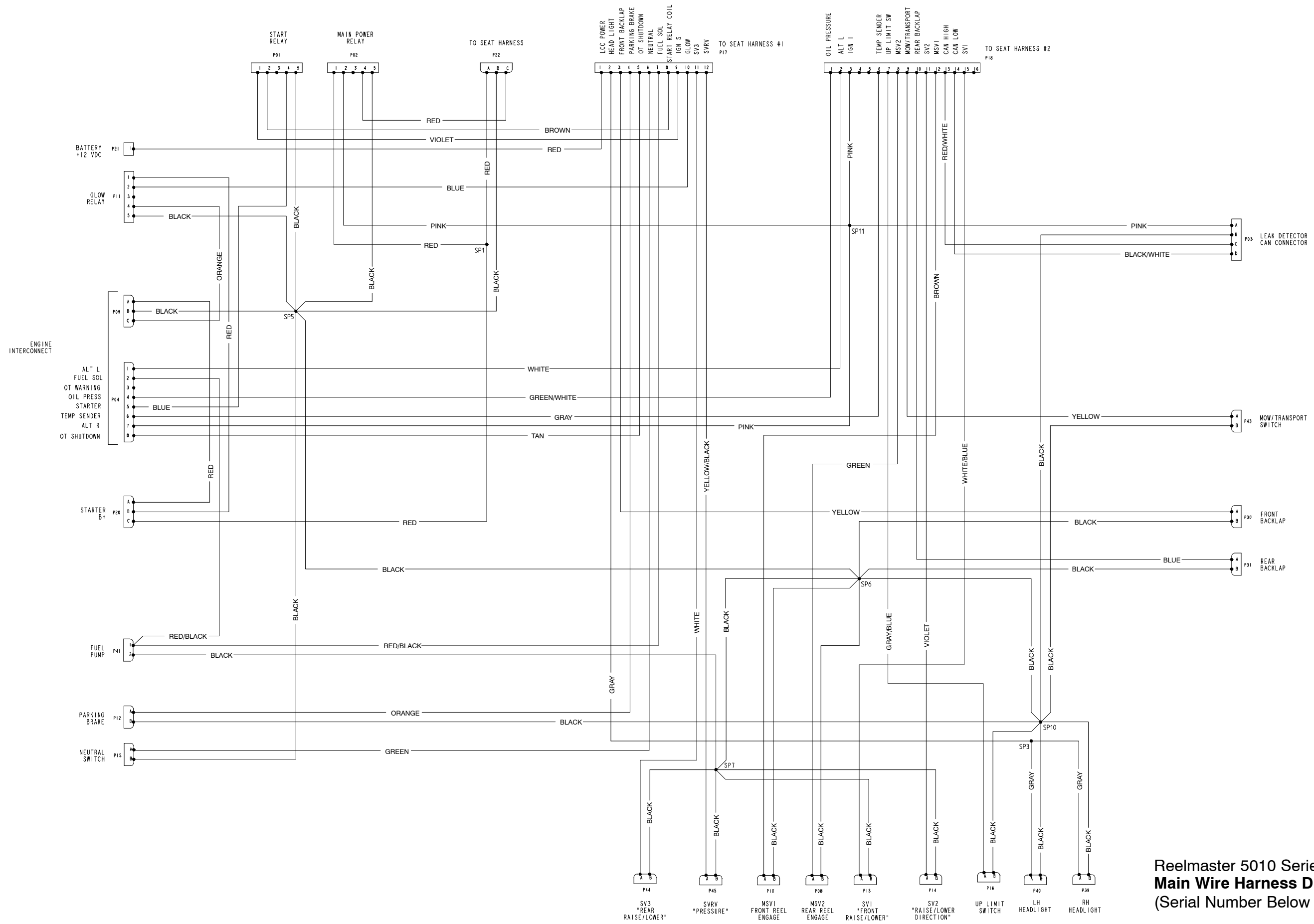

Reelmaster 5010 Series
Main Wire Harness Diagram
 (Serial Number Below 31000000)

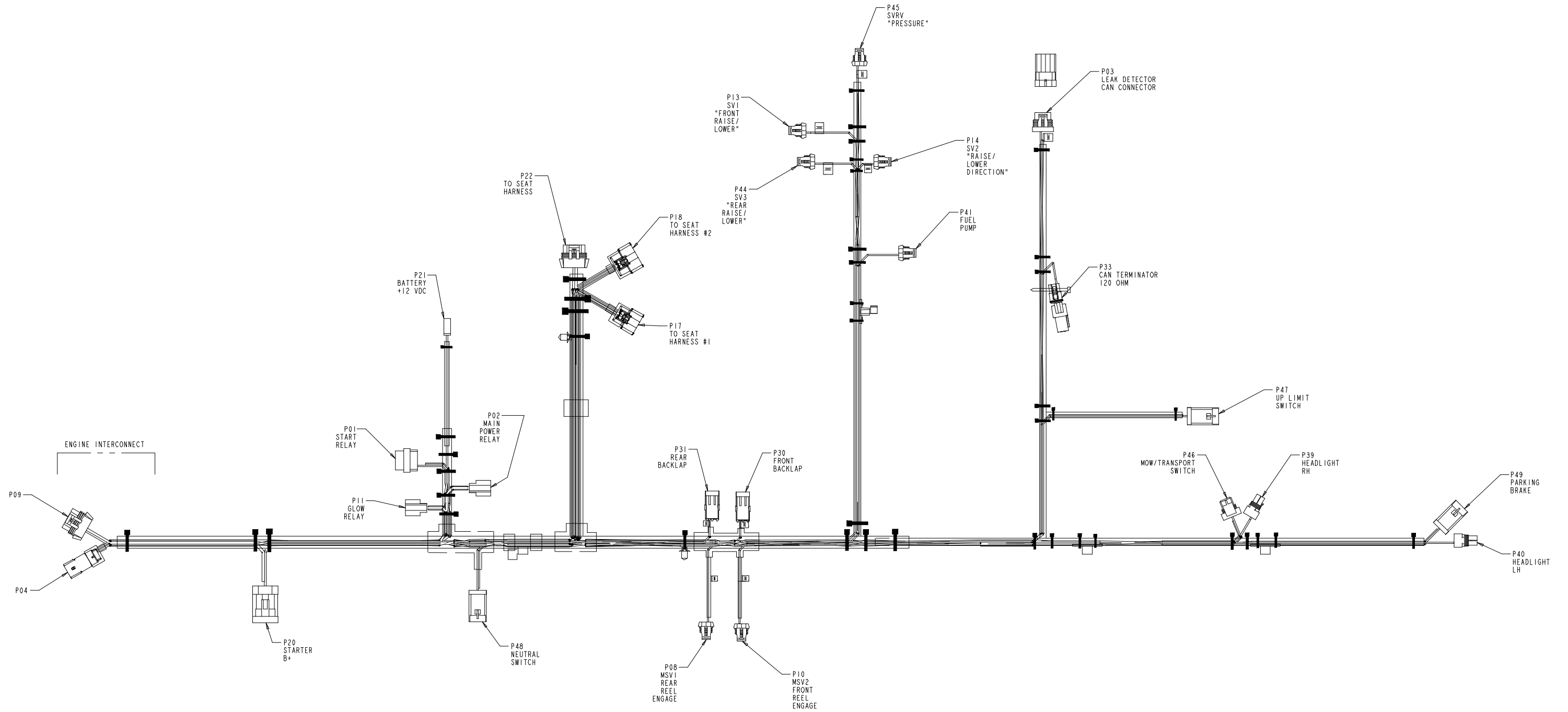

Reelmaster 5010 Series
Main Wire Harness Drawing
 (Serial Number Above 310000000)

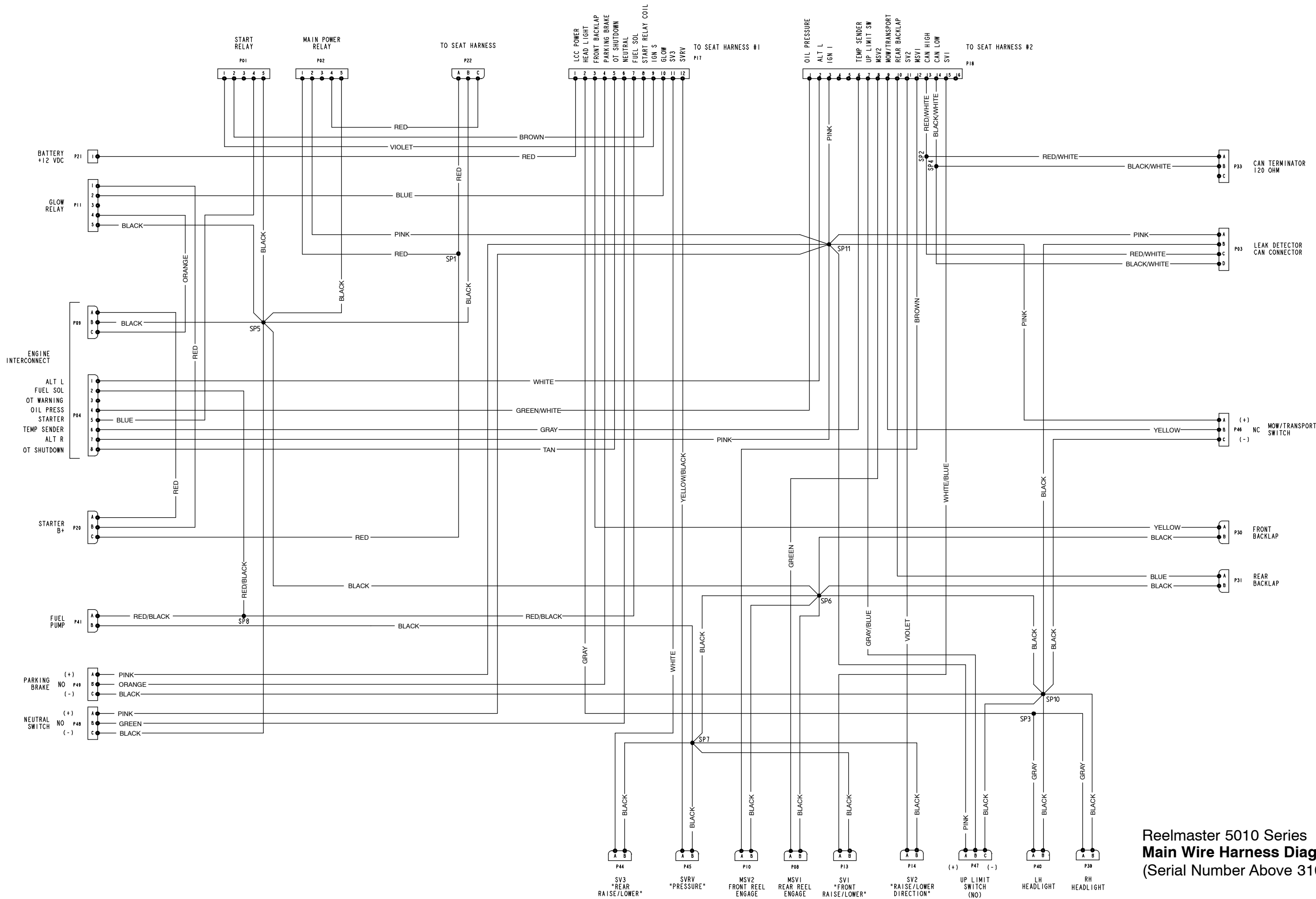

Reelmaster 5010 Series
Main Wire Harness Diagram
 (Serial Number Above 31000000)

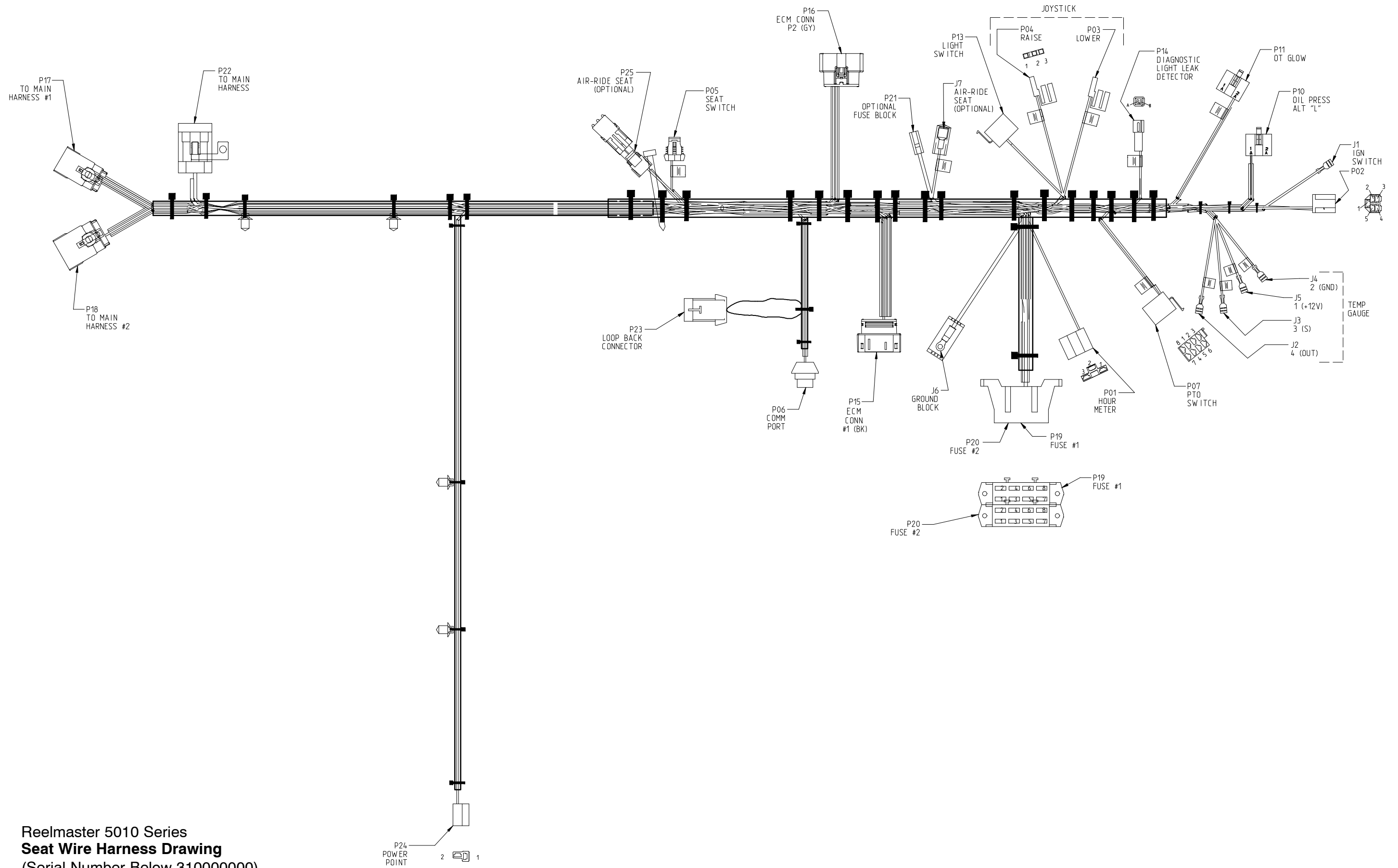

Reelmaster 5010 Series
Seat Wire Harness Drawing
 (Serial Number Below 310000000)

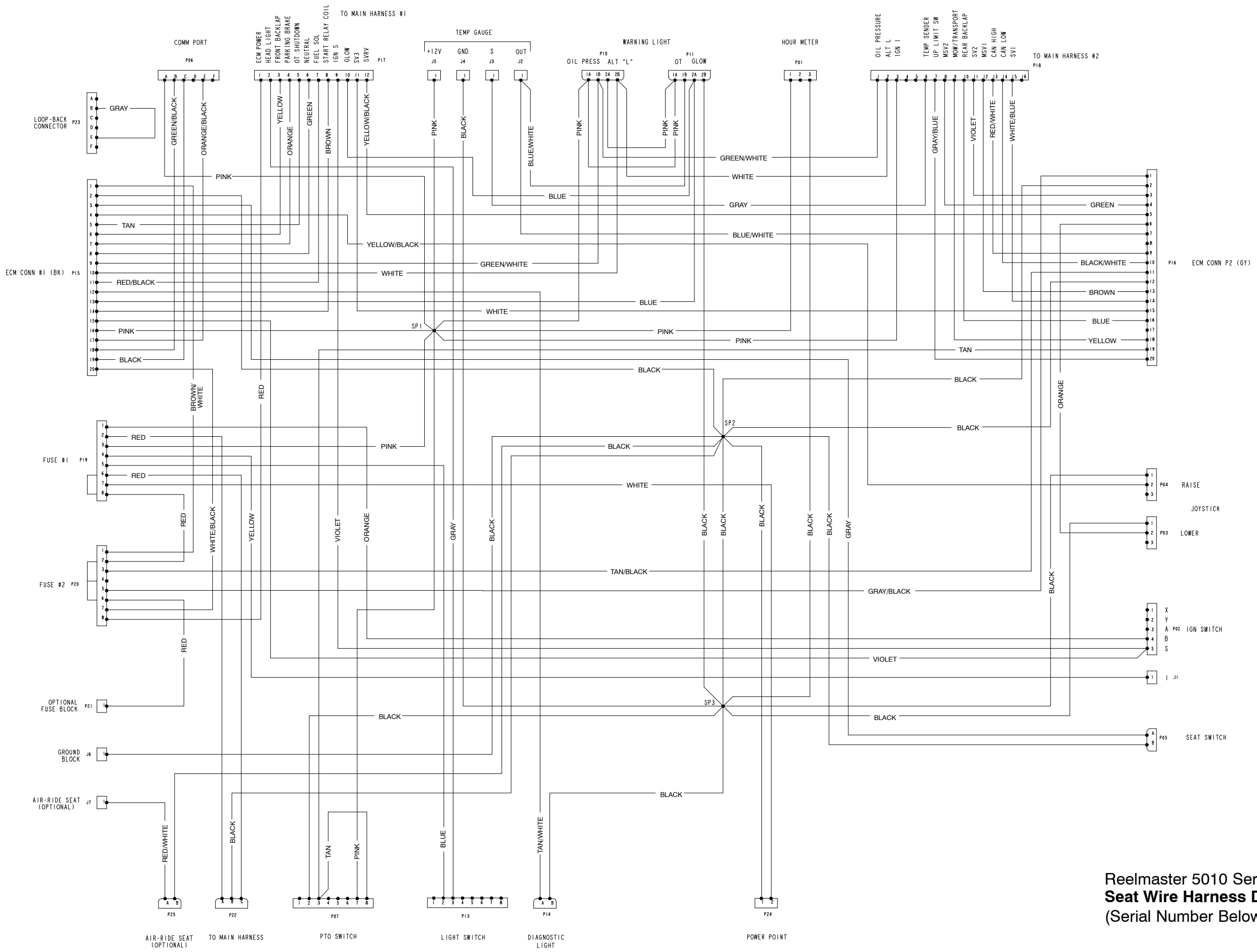

Reelmaster 5010 Series
Seat Wire Harness Diagram
 (Serial Number Below 31000000)

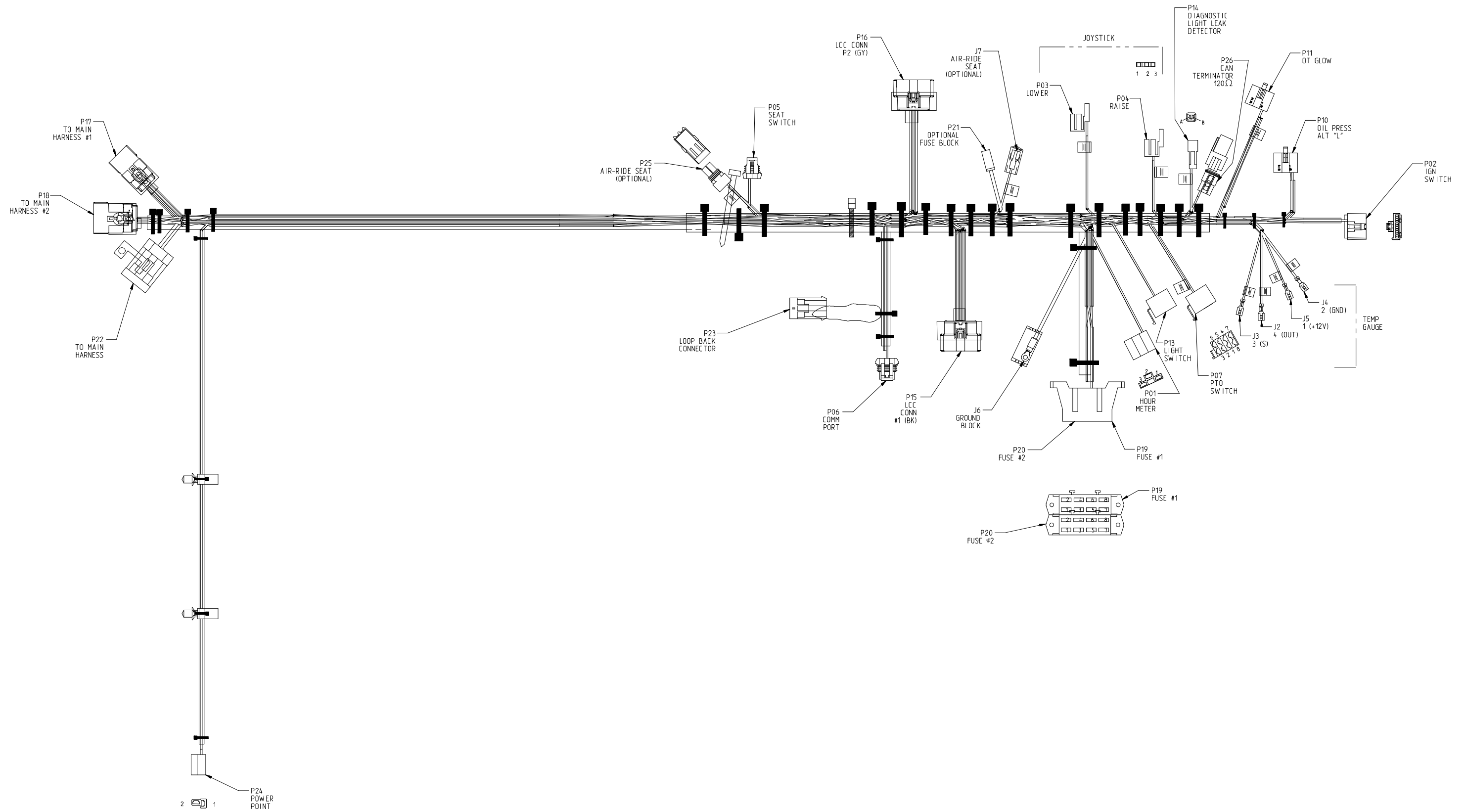

Reelmaster 5010 Series
Seat Wire Harness Drawing
 (Serial Number Above 310000000)

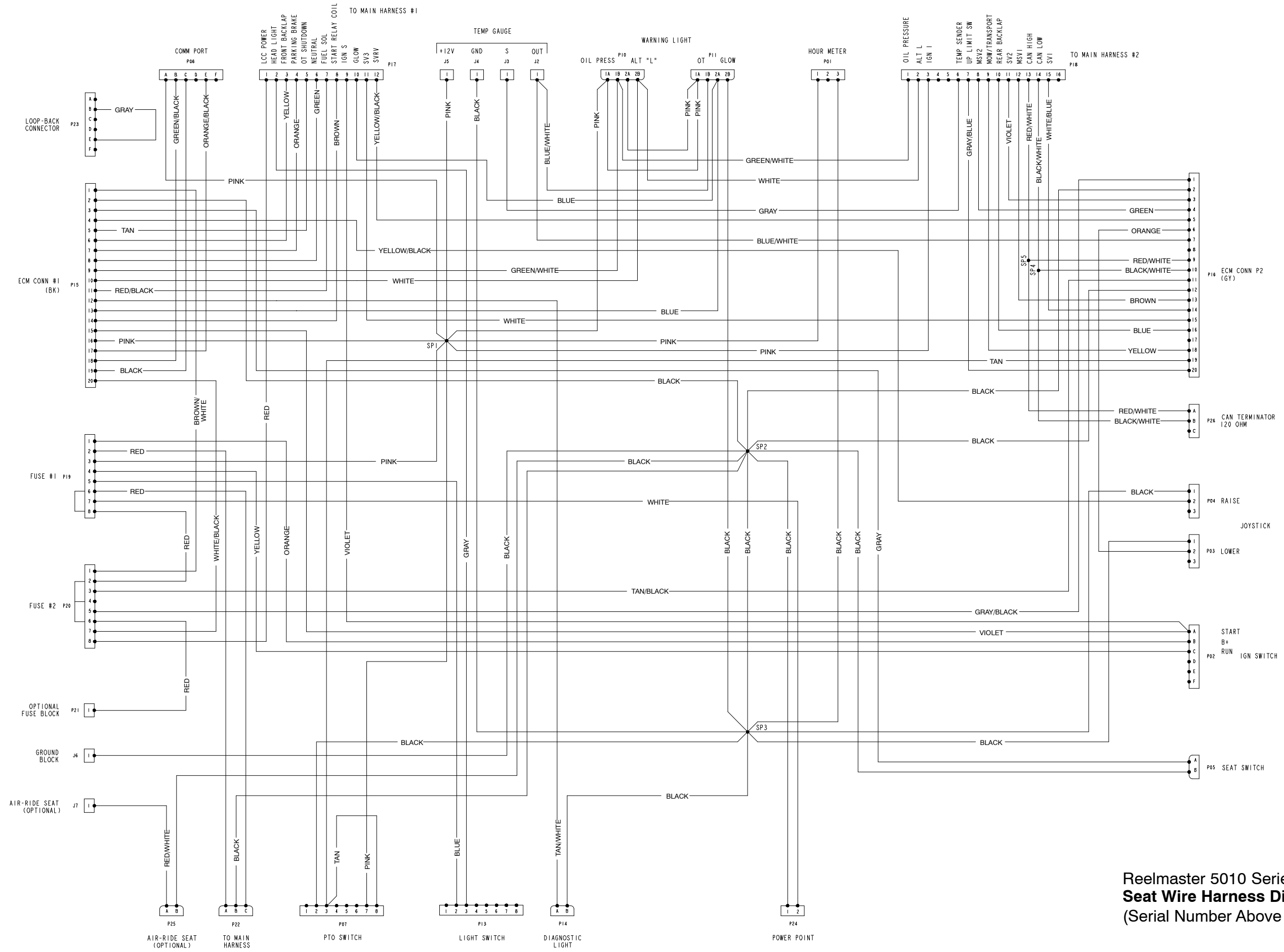

Reelmaster 5010 Series
 Seat Wire Harness Diagram
 (Serial Number Above 31000000)

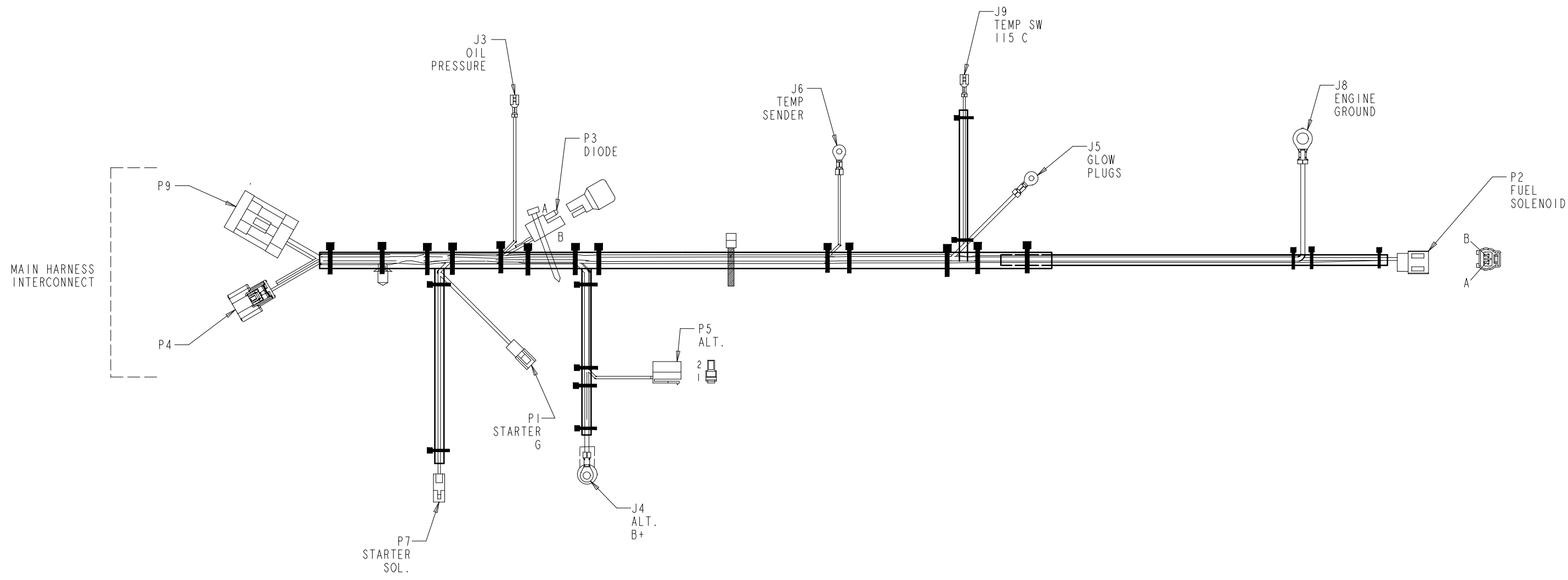

Reelmaster 5010 Series
Engine Wire Harness Drawing

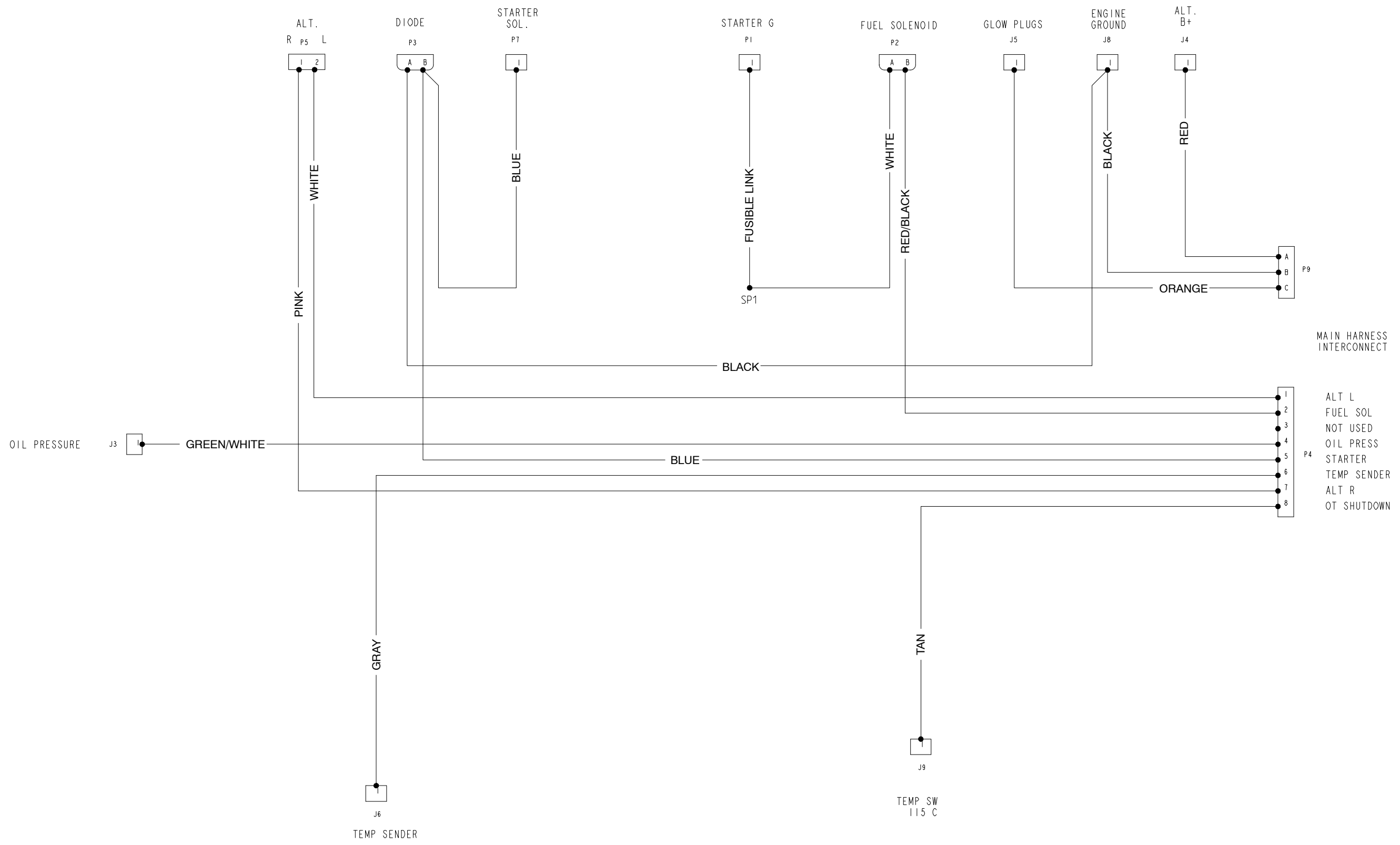

Reelmaster 5010 Series
Engine Wire Harness Diagram

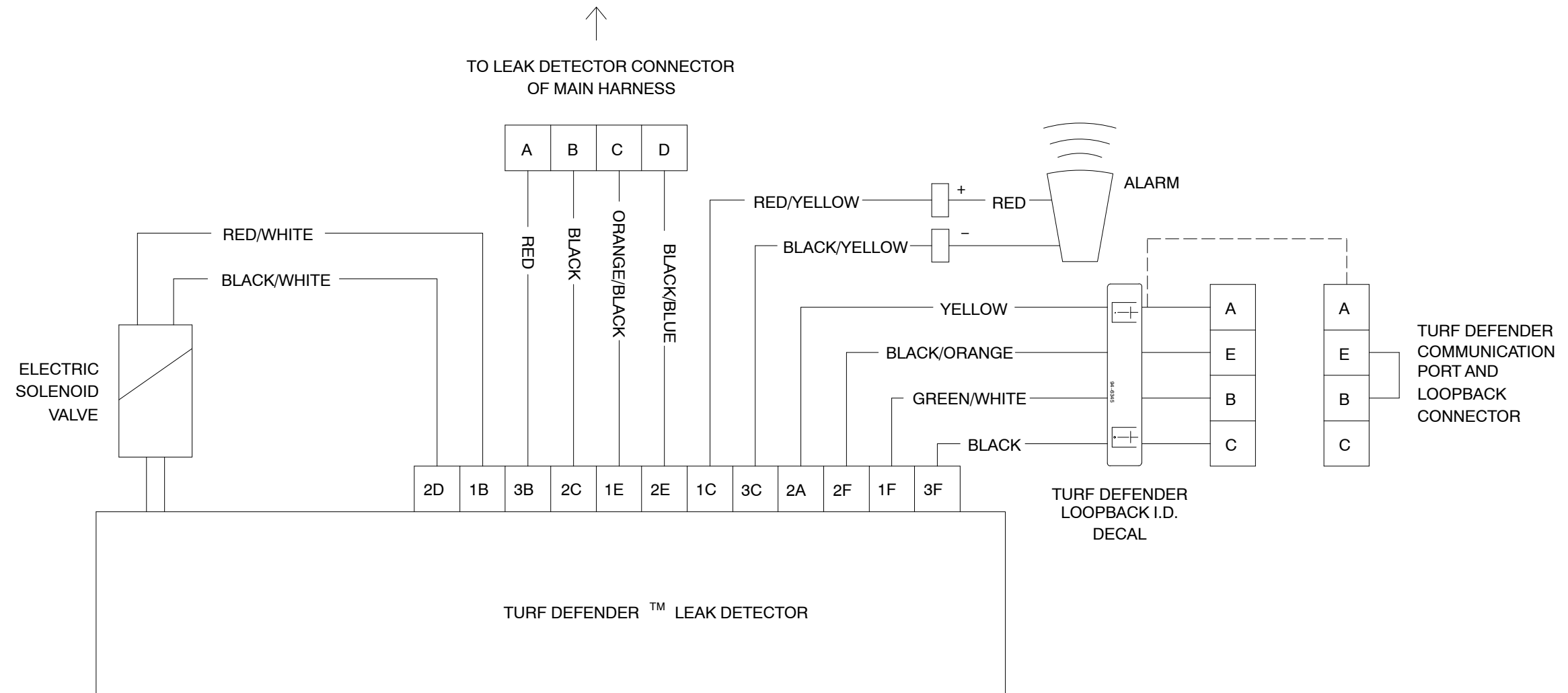

Reelmaster 5010 Series
TurfDefender™ (Optional)
 Electrical Schematic