



Count on it.

Operator's Manual

27in Rotary Cutting Unit

for Groundsmaster®

3500-D/3505-D/4500-D/4700-D Traction Units

Model No. 30834—Serial No. 290000001 and Up

This product complies with all relevant European directives, for details please see the separate product specific Declaration of Conformity (DOC) sheet.

Introduction

This rotary-blade lawn cutting deck is mounted to a ride-on machine and is intended to be used by professional, hired operators in commercial applications. It is primarily designed for cutting grass on well-maintained lawns in parks, sports fields, and on commercial grounds. It is not designed for cutting brush, mowing grass and other growth alongside highways, or for agricultural uses.

Read this information carefully to learn how to operate and maintain your product properly and to avoid injury and product damage. You are responsible for operating the product properly and safely.

You may contact Toro directly at www.Toro.com for product and accessory information, help finding a dealer, or to register your product.

Whenever you need service, genuine Toro parts, or additional information, contact an Authorized Service Dealer or Toro Customer Service and have the model and serial numbers of your product ready. The model and serial numbers are stamped on a plate on the rear of the cutting unit, under the cover. Write the numbers in the space provided.

| |
|-------------------------|
| Model No. _____ |
| Serial No. _____ |

This manual identifies potential hazards and has safety messages identified by the safety alert symbol (Figure 1), which signals a hazard that may cause serious injury or death if you do not follow the recommended precautions.



Figure 1

1. Safety alert symbol

This manual uses 2 other words to highlight information. **Important** calls attention to special mechanical information and **Note** emphasizes general information worthy of special attention.

Contents

| | |
|--|----|
| Introduction..... | 2 |
| Safety..... | 3 |
| Safety and Instructional Decals..... | 3 |
| Setup..... | 4 |
| Adjusting the Carrier Frame (Groundsmaster 3500 only)..... | 4 |
| Adjusting the Height-of-Cut..... | 4 |
| Adjusting the Roller Scraper (Optional)..... | 5 |
| Installing the Mulching Baffle (Optional)..... | 5 |
| Product Overview..... | 6 |
| Specifications..... | 6 |
| Dimensions and Weights (approx.)..... | 6 |
| Attachments/Accessories..... | 6 |
| Operation..... | 6 |
| Selecting a Blade..... | 6 |
| Operating Tips..... | 7 |
| Maintenance..... | 9 |
| Recommended Maintenance Schedule(s)..... | 9 |
| Using the Cutting Deck Service Latch (Groundsmaster 3500–D only)..... | 9 |
| Greasing the Bearings..... | 9 |
| Separating the Cutting Decks from the Traction Unit..... | 10 |
| Mounting the Cutting Decks to the Traction Unit..... | 10 |
| Servicing the Blade Plane..... | 10 |
| Removing the Cutter Blade..... | 11 |
| Inspecting and Sharpening the Blade..... | 12 |
| Checking the Blade Stopping Time..... | 13 |
| Servicing the Front Roller..... | 13 |
| Storage..... | 14 |

Safety

Safety and Instructional Decals



Safety decals and instructions are easily visible to the operator and are located near any area of potential danger. Replace any decal that is damaged or lost.

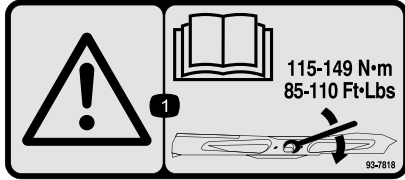

93-7818

1. Warning—read the *Operator's Manual* for instructions on torquing the blade bolt/nut to 115-149 N-m (85-110 ft-lb).

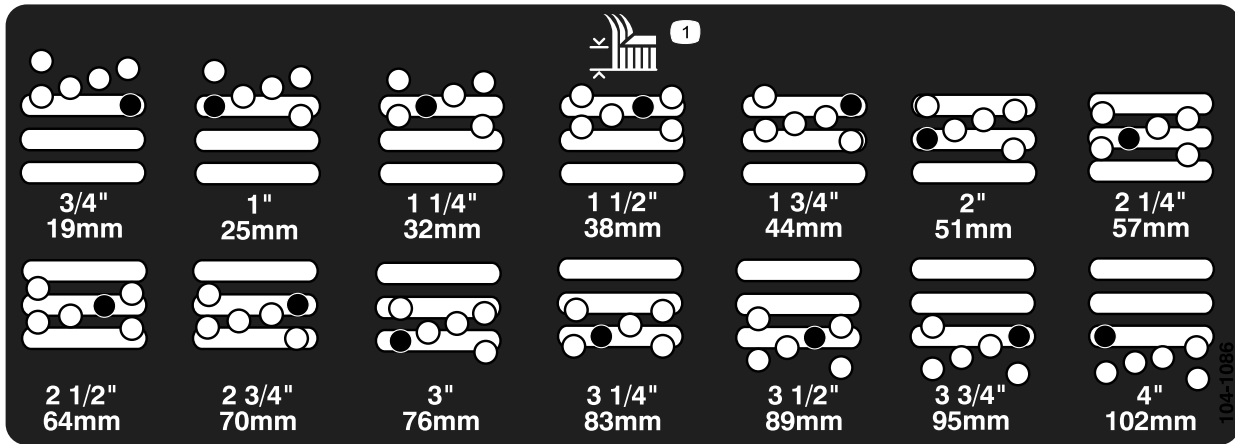

104-1086

1. Height of cut

Setup

Media and Additional Parts

| Description | Qty. | Use |
|-------------------|------|--|
| CE Decal | 1 | Apply to the cutting deck for CE compliance. |
| Operator's Manual | 1 | Read before operating. |
| Parts Catalog | 1 | Use to lookup parts. |

Adjusting the Carrier Frame (Groundsmaster 3500 only)

Adjusting the Front Cutting Decks

The front and rear cutting decks require different mounting positions. The front cutting deck has two mounting positions depending on what height-of-cut and degree of deck rotation you desire.

1. For heights of cut in the 3/4 to 3 inch (2 to 7.6 cm) range, mount the front carrier frames in the lower front mounting holes (Figure 2).

Note: This permits more up travel of the cutting decks relative to tractor when approaching quick uphill changes in terrain. It does however limit the clearance of the chamber to the carrier when cresting sharp knolls.

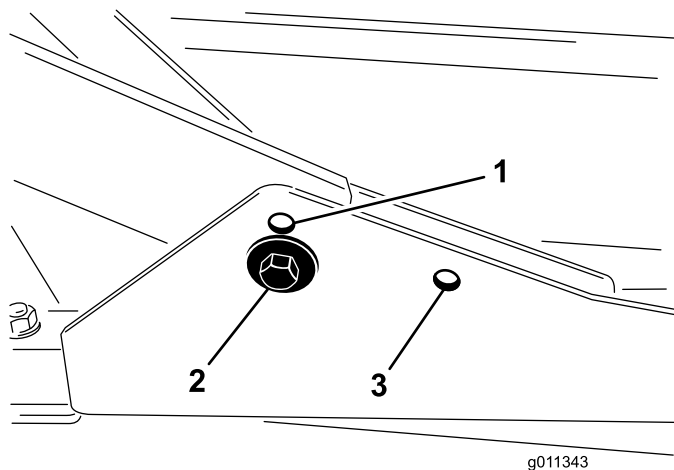

Figure 2

1. Front deck mounting hole (upper)
2. Front deck mounting hole (lower)
3. Rear deck mounting hole

Note: This increases the chamber to carrier clearance due to the higher position of the cutting chamber, but will cause the cutting deck to reach their maximum up travel sooner.

Adjusting the Rear Cutting Decks

The front and rear cutting decks require different mounting positions. The rear cutting deck has one mounting position for proper alignment with the sidewinder under frame.

For all heights of cut, mount the rear cutting deck in the rear mounting holes (Figure 2).

Adjusting the Height-of-Cut

Important: This cutting deck often cuts approximately 1/4 inch (6 mm) lower than a reel cutting unit with the same bench setting. It may be necessary to have these rotary cutting deck's bench set 1/4 inch (6 mm) above that of reels cutting in the same area.

Important: Access to the rear cutting units is greatly improved by removing the cutting unit from the tractor. If the unit is equipped with a Sidewinder®, sidewind the cutting units to the right, remove the rear cutting unit, and slide it out to the right side.

1. Lower the cutting deck to the ground, stop the engine, and remove the key from ignition switch.
2. Loosen the bolt securing each height-of-cut bracket to the height-of-cut plate (front and each side) (Figure 3).
3. Beginning with front adjustment, remove the bolt.

2. For heights of cut in the 2-1/2 to 4 inch (6.3 to 10 cm) range, mount the front carrier frames in the upper front mounting holes (Figure 2).

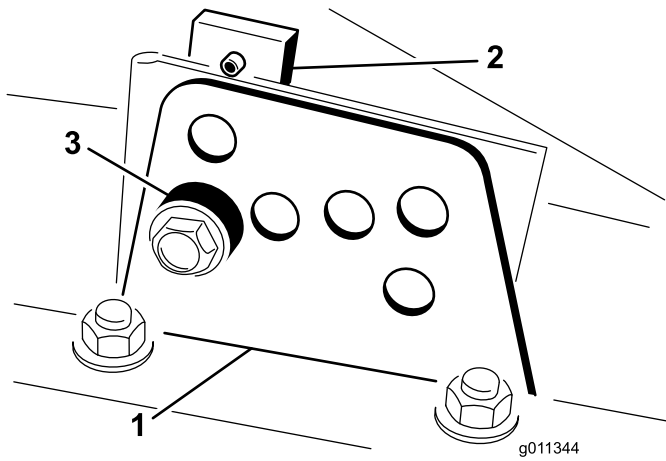

Figure 3

- 1. Height of cut bracket
- 2. Height of cut plate
- 3. Spacer

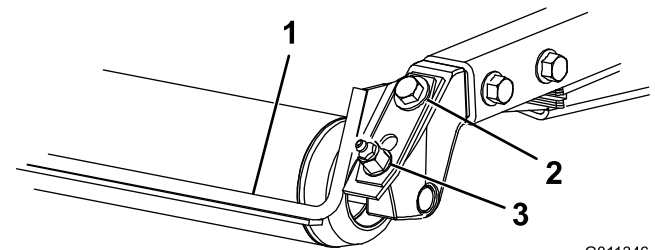

Figure 5

- 1. Roller spacer
- 2. Mounting screw
- 3. Grease fitting

4. While supporting the chamber, remove the spacer (Figure 3).
5. Move the chamber to the desired height-of-cut and install a spacer into the designated height-of-cut hole and slot (Figure 4).

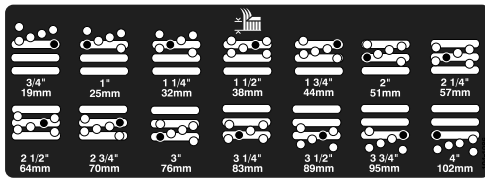

Figure 4

6. Position the tapped plate in line with the spacer.
7. Install the bolt finger tight.
8. Repeat steps 4–7 for each side adjustment.
9. Tighten all three bolts to 30 ft-lb (41 N-m). Always tighten the front bolt first.

Note: Adjustments of more than 1-1/2 inches (3.8 cm) may require temporary assembly to an intermediate height to prevent binding (e.g. changing from 1.25 to 2.75 inch (3.1 to 7 cm) height-of-cut).

Adjusting the Roller Scraper (Optional)

The optional rear roller scraper is designed to work best when there is an even gap of 0.020–0.040 inch (0.5 to 1 mm) between the scraper and roller.

1. Loosen the grease fitting and mounting screw (Figure 5).

2. Slide the scraper up or down until a gap of 0.020 to 0.040 inch (0.5 to 1 mm) is achieved between the rod and the roller.
3. Secure the grease fitting and screw to 30 ft-lb (41 N-m) in an alternating sequence.

Installing the Mulching Baffle (Optional)

1. Thoroughly clean debris from the mounting holes on the rear wall and left side wall of the chamber.
2. Install the mulching baffle in the rear opening and secure it with 5 flange head bolts (Figure 6).

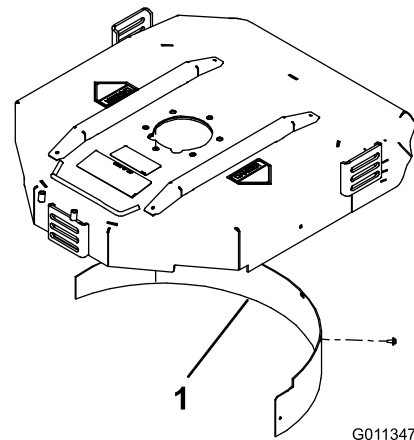

Figure 6

- 1. Mulching baffle

3. Verify that mulching baffle does not interfere with the tip of the blade and does not protrude inside the surface of the rear chamber wall.

⚠

Do not use the high lift blade with the mulching baffle. The blade could break, resulting in personal injury or death.

Product Overview

Specifications

Note: Specifications and design are subject to change without notice.

Dimensions and Weights (approx.)

| | |
|--------|---|
| Length | 34 inches (86.4 cm) |
| Width | 34 inches (86.4 cm) |
| Height | 9.6 inches (24.4 cm) to carrier mount 10–1/2 inches (26.7 cm) at 3/4 inch height of cut 13–3/4 inches (34.9 cm) at 4 inch height of cut |
| Weight | 195 pounds (88 kg) |

Attachments/Accessories

A selection of Toro approved attachments and accessories are available for use with the machine to enhance and expand its capabilities. Contact your Authorized Service Dealer or Distributor or go to www.Toro.com for a list of all approved attachments and accessories.

Operation

Note: Determine the left and right sides of the machine from the normal operating position.

Selecting a Blade

Standard Combination Sail

This blade was designed to provide excellent lift and dispersion in almost any condition. If more or less lift and discharge velocity is required, consider a different blade.

Attributes: Excellent lift and dispersion in most conditions.

Angled Sail

The blade generally performs best in lower heights of cut—3/4 to 2–1/2 inch (1.9 to 6.4 cm).

Attributes:

- Discharge remains more even at lower heights of cut.
- Discharge has less tendency to throw left and thus a cleaner look around bunkers and fairways.
- Lower power requirement at lower heights and dense turf.

High Lift Parallel Sail

The blade generally performs better in the higher heights of cut—2 to 4 inch (7 to 10 cm).

Attributes:

- More lift and higher discharge velocity.
- Sparse or limp turf is picked up significantly at higher heights of cut.
- Wet or sticky clippings are discharged more efficiently reducing congestion in the deck.
- Requires more horsepower to run.
- Tends to discharge further left and can tend to windrow at lower heights of cut.



Do not use the high lift blade with the mulching baffle. The blade could break, resulting in personal injury or death.

Atomic Blade

This blade was designed to provide excellent leaf mulching.

Attributes: Excellent leaf mulching

Operating Tips

Mow when the Grass is Dry

Mow either in the late morning to avoid the dew, which causes grass clumping, or in late afternoon to avoid the damage that can be caused by direct sunlight on the sensitive, freshly mowed grass.

Select the Proper Height-of-Cut Setting to Suit Conditions

Remove approximately one inch or no more than 1/3 of the grass blade when cutting. In exceptionally lush and dense grass you may have to raise your height-of-cut setting another notch.

Always Start Mowing with Sharp Blades

A sharp blade cuts cleanly and without tearing or shredding the grass blades like a dull blade. Tearing and shredding causes the grass to turn brown at the edges which impairs growth and increases susceptibility to diseases. Make sure blade is in good condition and a full sail is present.

Check Condition of Deck

Make sure that the cutting chambers are in good condition. Straighten any bends in the chamber components to ensure the correct blade tip/chamber clearance.

After Operating

To ensure optimum performance, clean the underside of mower housing. If you allow residue to build up in mower housing, cutting performance will decrease.

Choosing Accessories

| Optional Equipment Configuration | | | | |
|--|---|---|--|--|
| | Angle Sail Blade | High Lift Parallel Sail Blade <i>Do not use with the mulching baffle</i> | Mulching Baffle | Roller Scraper |
| Grass Cutting: 0.75 to 1.75 inch (1.9 to 4.4 cm) Height-of-Cut | Recommended in most applications | May work well in light or sparse turf | Has been shown to improve dispersion and after cut performance on northern grasses that are cut at least three times per week and less than 1/3 of the grass blade is removed. Do not use with the high lift parallel sail blade | Can be used any time that rollers build up with grass or large flat grass clumps of grass are seen. The scrapers may actually increase clumping in certain applications. |
| Grass Cutting: 2.00 to 2.50 inch (5 to 6.4 cm) Height-of-Cut | Recommended for thick or lush turf | Recommended for light or sparse turf | | |
| Grass Cutting: 2.75 to 4.00 inch (7 to 10 cm) Height-of-Cut | May work well in lush turf | Recommended in most applications | | |
| Leaf Mulching | Recommended for use with the mulching baffle | Not Allowed | Use with combination sail or angle sail blade only | |
| Pros | Even discharge at lower height of cut Cleaner look around bunkers and fairways Lower power requirements | More lift and higher discharge velocity Sparse or limp turf is picked up at high height of cut Wet or sticky clippings are discharged efficiently | May improve dispersion and appearance in certain grass cutting applications Very good for leaf mulching | Reduces roller buildup in certain applications |
| Cons | Does not lift the grass well in high height of cut applications Wet or sticky grass has a tendency to build up in the chamber, leading to poor quality of cut and higher power requirement | Requires more power to run in some applications Tends to windrow at lower height of cut in lush grass Do not use with the mulching baffle | Grass will build up in the chamber if attempting to remove too much grass with baffle in place | |

Maintenance

Note: Determine the left and right sides of the machine from the normal operating position.

Recommended Maintenance Schedule(s)

| Maintenance Service Interval | Maintenance Procedure |
|------------------------------|--|
| Before each use or daily | <ul style="list-style-type: none">• Check the blade stopping time. |
| Every 50 hours | <ul style="list-style-type: none">• Grease the bearings |



If you leave the key in the ignition switch, someone could accidentally start the engine and seriously injure you or other bystanders.

Remove the key from the ignition and disconnect the wire from the spark plug before you do any maintenance. Set the wire aside so that it does not accidentally contact the spark plug.

Using the Cutting Deck Service Latch (Groundsmaster 3500–D only)

When servicing the cutting decks, use the service latch to prevent injury.

1. Center the cutting deck sidewinder with the traction unit.
2. Raise the cutting decks to the transport position.
3. Set the parking brake and turn off the machine.
4. Release the latch rod (Figure 7) from front carrier frame retainer.

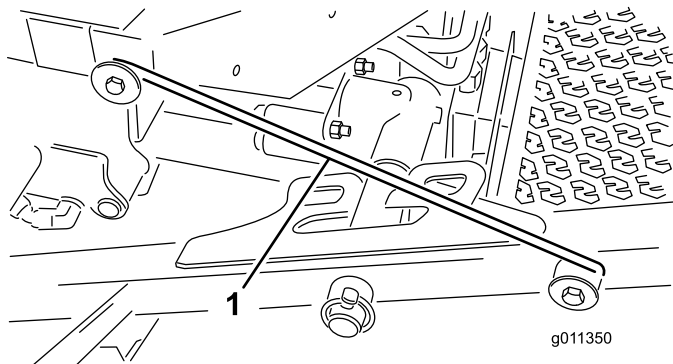

Figure 7

1. Service latch hook

5. Lift the outside of the front cutting decks and place the latch over the frame pin mounted on the front of the operator's platform (Figure 7).
6. Sit on the operator seat and start the traction unit.

7. Lower the cutting decks to the mow position.
8. Turn off the machine and remove the key.
9. Reverse this procedure to unlatch the cutting decks.

Greasing the Bearings

Service Interval: Every 50 hours

Each cutting deck has two grease fittings per spindle. Either fitting can be used, whichever is more accessible. If the machine is operated under normal conditions, lubricate blade spindle bearings (Figure 8) with No. 2 general purpose lithium base grease or molybdenum base grease, after every 50 hours of operation. Pump grease into the fitting until a small amount appears at bottom of the spindle housing (under the deck).

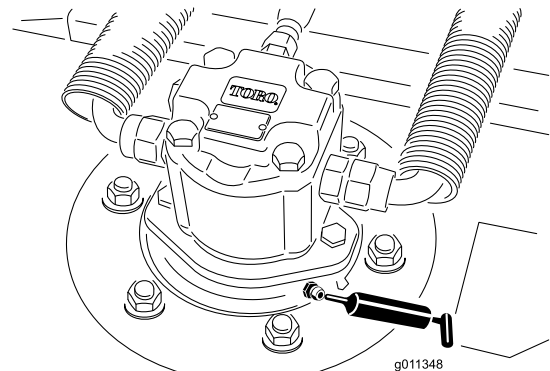

Figure 8

Each cutting deck has two grease fittings per rear roller. If the machine is operated under normal conditions, lubricate rear roller bearings (Figure 9) with No. 2 general purpose lithium base grease or molybdenum base grease, after every 50 hours of operation.

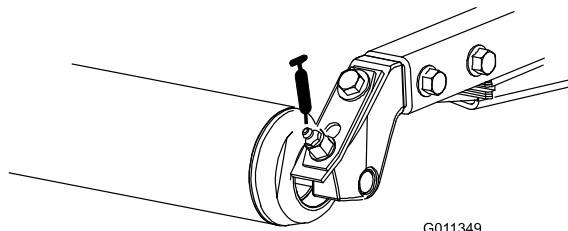

Figure 9

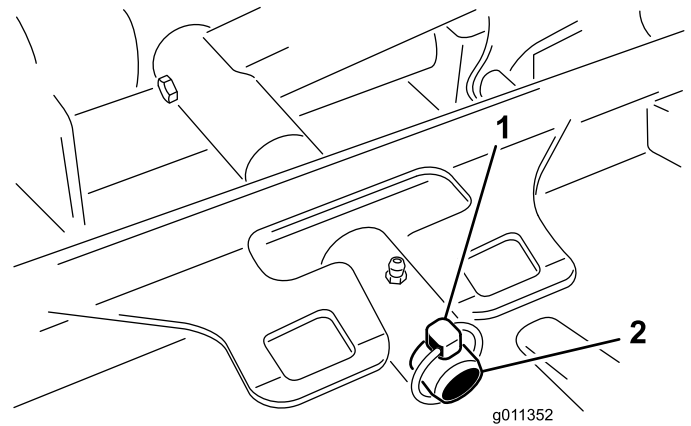

Figure 11

1. Lynch pin
2. Lift arm pivot pin

Important: Make sure the grease groove in each roller mount aligns with the grease hole in each end of the roller shaft. To help align the groove and hole, there is also an alignment mark on one end of the roller shaft.

Separating the Cutting Decks from the Traction Unit

1. Position the machine on a level surface, lower the cutting decks to the floor, shut the engine off, and engage the parking brake.
2. Disconnect and remove the hydraulic motor from the deck (Figure 10). Cover the top of the spindle to prevent contamination.

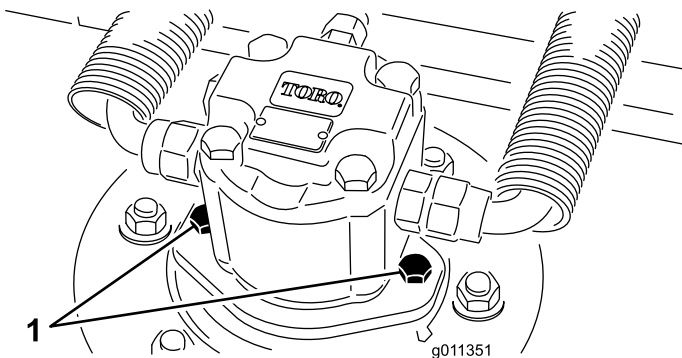

Figure 10

1. Motor mounting screws

3. Remove the lynch pin or retaining nut (GM 4700 only) securing the deck carrier frame to the lift arm pivot pin (Figure 11).

4. Roll the cutting deck away from the traction unit.

Mounting the Cutting Decks to the Traction Unit

1. Position machine on a level surface and shut engine off.
2. Move cutting deck into position in front of traction unit.
3. Slide deck carrier frame onto lift arm pivot pin. Secure with lynch pin or retaining nut (GM 4700 only) (Figure 11).
4. Install the hydraulic motor to the deck (Figure 10). Make sure that the O-ring is in position and not damaged.
5. Grease the spindle.

Servicing the Blade Plane

The rotary deck comes from the factory preset at 2.00 inch (5 cm) height-of-cut and blade rake of 0.310 inch (7.9 mm). The left-hand and right-hand heights are also preset to within ± 0.030 inch (0.7 mm) of the other.

The cutting deck is designed to withstand blade impacts without deformation of the chamber. If a solid object is struck, inspect the blade for damage and the blade plane for accuracy.

Inspecting the Blade Plane

1. Remove the hydraulic motor from the cutting deck and remove the cutting deck from the tractor.
2. Use a hoist (or minimum of two people) and place the cutting deck on a flat table.
3. Mark one end of the blade with a paint pen or marker. Use this end of the blade to check all heights.

- Position the cutting edge of the marked end of the blade at 12 o'clock (straight ahead in the direction of mowing) (Figure 12) and measure height from table to cutting edge of blade.

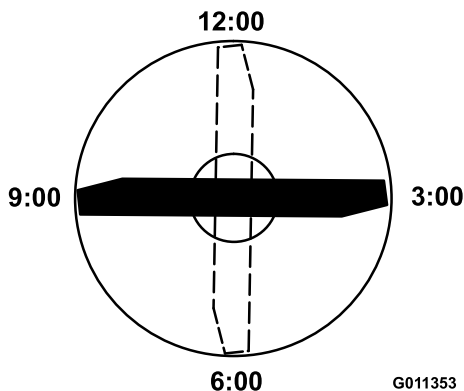

Figure 12

- Rotate the marked end of the blade to the 3 and 9 o'clock positions (Figure 12) and measure the heights.
- Compare the 12 o'clock measured height to the height-of-cut setting. It should be within 0.030 inch (0.7 mm). The 3 and 9 o'clock heights should be 0.150 ± 0.090 inch (3.8 ± 2.2 mm) higher than the 12 o'clock setting and within 0.090 inch (2.2 mm) of each other.

If any of these measurements are not within specification, proceed to Adjusting the Blade Plane.

Adjusting the Blade Plane

Start with the front adjustment (change one bracket at a time).

- Remove the height-of-cut bracket, (front, left, or right) from the deck frame (Figure 13).
- Adjust 0.060 inch (1.5 mm) shims and/or 0.030 inch (0.7 mm) shim between the deck frame and bracket to achieve the desired height setting (Figure 13).

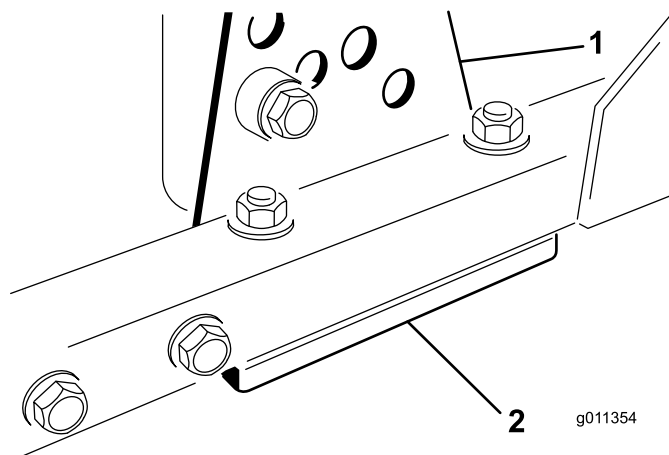

Figure 13

- Height of cut bracket
- Shims

- Install the height-of-cut bracket to the deck frame with the remaining shims assembled below the height-of-cut bracket.
- Secure the socket head bolt/spacer and flange nut.

Note: Socket head bolt/spacer are held together with Loctite to prevent the spacer from falling inside the deck frame.
- Verify the 12 o'clock height and adjust if needed.
- Determine if only one or both (right-hand and left-hand) height-of-cut brackets need to be adjusted. If the 3 or 9 o'clock side is 0.150 ± 0.090 inch (3.8 ± 2.2 mm) higher than the new front height then no adjustment is needed for that side. Adjust the other side to within ± 0.090 inch (2.2 mm) of the correct side.
- Adjust the right and/or left height-of-cut brackets by repeating steps 1 through 3.
- Secure the carriage bolts and flange nuts.
- Again, verify the 12, 3, and 9 o'clock heights.

Removing the Cutter Blade

The blade must be replaced if a solid object is hit, the blade is out of balance, or if the blade is bent. Always use genuine Toro replacement blades to be sure of safety and optimum performance. Never use replacement blades made by other manufacturers because they could be dangerous.

- Raise the cutting deck to the highest position, shut the engine off, and engage the parking brake. Block the cutting deck to prevent it from falling accidentally.
- Grasp the end of the blade using a rag or thickly padded glove. Remove the blade bolt, anti-scalp cup, and blade from the spindle shaft (Figure 14).

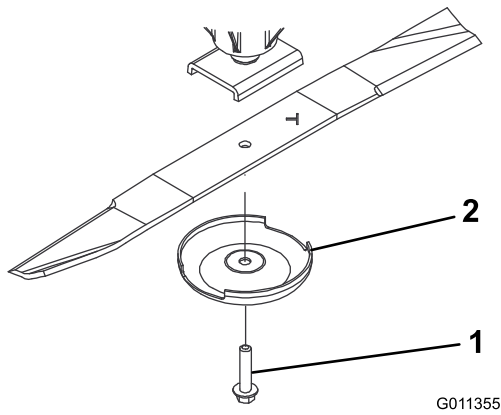

Figure 14

1. Blade bolt
2. Anti-scalp cup

3. Install the blade, sail facing toward the cutting deck, with the anti-scalp cup and blade bolt (Figure 14). Tighten blade bolt to 85–110 ft-lb (115–149 N-m).



A worn or damaged blade can break, and a piece of the blade could be thrown into the operator's or bystander's area, resulting in serious personal injury or death.

- Inspect the blade periodically for wear or damage.
- Never weld a broken or cracked blade.
- Always replace a worn or damaged blade.

Inspecting and Sharpening the Blade

1. Raise the cutting deck to the highest position, shut the engine off, and engage the parking brake. Block the cutting deck to prevent it from falling accidentally. On the Groundsmaster 3500, secure the cutting deck service latch.
2. Examine the cutting ends of the blade carefully, especially where the flat and curved parts of the blade meet (Figure 15). Since sand and abrasive material can wear away the metal that connects the flat and curved parts of the blade, check the blade before using the machine. If wear is noticed (Figure 15), replace the blade; refer to Removing the Cutter Blade.

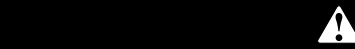

If the blade is allowed to wear, a slot will form between the sail and flat part of the blade (Figure 15). Eventually a piece of the blade may break off and be thrown from under the housing, possibly resulting in serious injury to yourself or bystanders.

- Inspect the blade periodically for wear or damage.
- Always replace a worn or damaged blade.

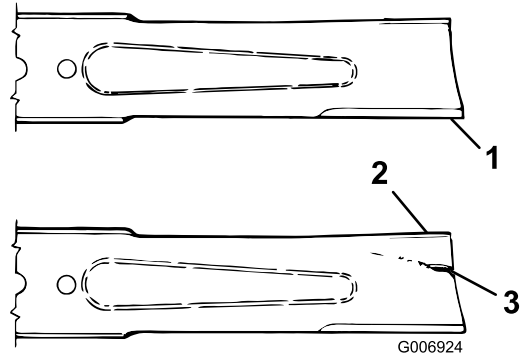

Figure 15

1. Cutting edge
2. Sail
3. Wear/slot/crack

3. Inspect the cutting edges of all blades. Sharpen the cutting edges if they are dull or nicked. Sharpen only the top of the cutting edge and maintain the original cutting angle to make sure of sharpness (Figure 16). The blade will remain balanced if the same amount of metal is removed from both cutting edges.



Figure 16

1. Sharpen at this angle only
4. To check the blade for being straight and parallel, lay the blade on a level surface and check its ends. The ends of the blade must be slightly lower than the center, and the cutting edge must be lower than the heel of the blade. This blade will produce good quality of cut and require minimal power from the engine. By contrast a blade that is higher at the ends than the center, or if cutting edge is higher than

the heel, the blade is bent or warped and must be replaced.

5. Install the blade, sail facing toward cutting deck, with the anti-scalp cup and blade bolt. Tighten the blade bolt to 85–110 ft-lb (115–149 N-m).

Checking the Blade Stopping Time

Service Interval: Before each use or daily

The blades of the cutting deck should come to a complete stop in approximately 5 seconds after you shut down the cutting deck engagement switch.

Note: Make sure the decks are lowered onto a clean section of turf or hard surface to avoid thrown dust and debris.

To verify this stopping time, have a second person stand back from the deck at least 20 feet (6 m) and watch the blades on one of the cutting decks. Have the operator shut the cutting decks down and record the time it takes for the blades to come to a complete stop. If this time is greater than 7 seconds, the braking valve needs adjustment. Call your Toro Distributor for assistance in making this adjustment.

Servicing the Front Roller

Inspect the front roller for wear, excess wobble, or binding. Service or replace the roller or components if any of these conditions exist.

Disassembling the Front Roller

1. Remove the roller mounting bolt (Figure 17).
2. Insert a punch through the end of the roller housing and drive the opposite bearing out by alternating taps to the opposite side of inner bearing race. There should be a 0.060 inch (1.5 mm) lip of inner race exposed.

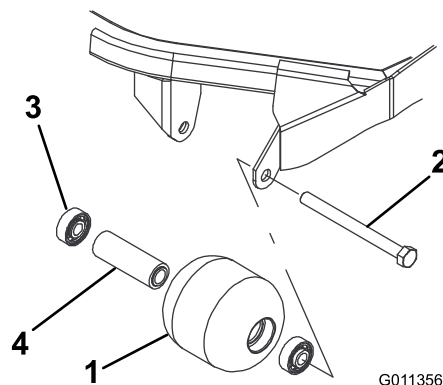

Figure 17

G011356

1. Front roller
2. mounting bolt
3. Bearing
4. Bearing spacer

3. Push the second bearing out in press.
4. Inspect the roller housing, bearings, and bearing spacer for damage (Figure 17). Replace damaged components and assemble.

Assembling the Front Roller

1. Press the first bearing into the roller housing (Figure 17). Press on the outer race only or equally on the inner and outer race.
2. Insert the spacer (Figure 17).
3. Press the second bearing into the roller housing (Figure 17) pressing equally on the inner and outer race until the inner race comes in contact with the spacer.
4. Install the roller assembly into the deck frame.

Important: Securing the roller assembly with a gap larger than 0.060 inch (1.5 mm) creates a side load on the bearing and can lead to premature bearing failure.

5. Verify that there is no more than a 0.060 inch gap between roller assembly and the roller mount brackets of the deck frame. If there is a gap over 0.060 inch, install enough 5/8 inch diameter washers to take up the slop.
6. Secure the mounting bolt to 80 ft-lb (108 N-m).

Storage

If the cutting deck is separated from the traction unit for any length of time, install a spindle plug in the top of the spindle to protect the spindle from dust and water.

Notes:



Toro General Commercial Products Warranty

A Two-Year Limited Warranty

Conditions and Products Covered

The Toro Company and its affiliate, Toro Warranty Company, pursuant to an agreement between them, jointly warrant your Toro Commercial Product ("Product") to be free from defects in materials or workmanship for two years or 1500 operational hours*, whichever occurs first. This warranty is applicable to all products with the exception of Aerators (refer to separate warranty statements for these products). Where a warrantable condition exists, we will repair the Product at no cost to you including diagnosis, labor, parts, and transportation. This warranty begins on the date the Product is delivered to the original retail purchaser.

* Product equipped with hour meter

Instructions for Obtaining Warranty Service

You are responsible for notifying the Commercial Products Distributor or Authorized Commercial Products Dealer from whom you purchased the Product as soon as you believe a warrantable condition exists. If you need help locating a Commercial Products Distributor or Authorized Dealer, or if you have questions regarding your warranty rights or responsibilities, you may contact us at:

Toro Commercial Products Service Department
Toro Warranty Company
8111 Lyndale Avenue South
Bloomington, MN 55420-1196
952-888-8801 or 800-952-2740
E-mail: commercial.warranty@toro.com

Owner Responsibilities

As the Product owner, you are responsible for required maintenance and adjustments stated in your *Operator's Manual*. Failure to perform required maintenance and adjustments can be grounds for disallowing a warranty claim.

Items and Conditions Not Covered

Not all product failures or malfunctions that occur during the warranty period are defects in materials or workmanship. This warranty does not cover the following:

- Product failures which result from the use of non-Toro replacement parts, or from installation and use of add-on, or modified non-Toro branded accessories and products. A separate warranty may be provided by the manufacturer of these items.
- Product failures which result from failure to perform recommended maintenance and/or adjustments. Failure to properly maintain your Toro product per the Recommended Maintenance listed in the *Operator's Manual* can result in claims for warranty being denied.
- Product failures which result from operating the Product in an abusive, negligent or reckless manner.
- Parts subject to consumption through use unless found to be defective. Examples of parts which are consumed, or used up, during normal Product operation include, but are not limited to, brake pads and linings, clutch linings, blades, reels, rollers and bearings (sealed or greasable), bed knives, aerator crankshaft and stomper arm bearings, tines, spark plugs, castor wheels and bearings, tires, filters, belts, and certain sprayer components such as diaphragms, nozzles, and check valves, etc.

- Failures caused by outside influence. Conditions considered to be outside influence include, but are not limited to, weather, storage practices, contamination, use of unapproved coolants, lubricants, additives, fertilizers, water, or chemicals, etc.
- Normal noise, vibration, wear and tear, and deterioration.
- Normal "wear and tear" includes, but is not limited to, damage to seats due to wear or abrasion, worn painted surfaces, scratched decals or windows, etc.

Parts

Parts scheduled for replacement as required maintenance are warranted for the period of time up to the scheduled replacement time for that part. Parts replaced under this warranty are covered for the duration of the original product warranty and become the property of Toro. Toro will make the final decision whether to repair any existing part or assembly or replace it. Toro may use remanufactured parts for warranty repairs.

Note Regarding Deep Cycle Battery Warranty:

Deep cycle batteries have a specified total number of kilowatt-hours they can deliver during their lifetime. Operating, recharging, and maintenance techniques can extend or reduce total battery life. As the batteries in this product are consumed, the amount of useful work between charging intervals will slowly decrease until the battery is completely worn out. Replacement of worn out batteries, due to normal consumption, is the responsibility of the product owner. Battery replacement may be required during the normal product warranty period at owner's expense.

Maintenance is at Owner's Expense

Engine tune-up, lubrication cleaning and polishing, replacement of filters, coolant, and completing recommended maintenance are some of the normal services Toro products require that are at the owner's expense.

General Conditions

Repair by an Authorized Toro Distributor or Dealer is your sole remedy under this warranty.

Neither The Toro Company nor Toro Warranty Company is liable for indirect, incidental or consequential damages in connection with the use of the Toro Products covered by this warranty, including any cost or expense of providing substitute equipment or service during reasonable periods of malfunction or non-use pending completion of repairs under this warranty. Except for the Emissions warranty referenced below, if applicable, there is no other express warranty. All implied warranties of merchantability and fitness for use are limited to the duration of this express warranty.

Some states do not allow exclusions of incidental or consequential damages, or limitations on how long an implied warranty lasts, so the above exclusions and limitations may not apply to you. This warranty gives you specific legal rights, and you may also have other rights which vary from state to state.

Note regarding engine warranty:

The Emissions Control System on your Product may be covered by a separate warranty meeting requirements established by the U.S. Environmental Protection Agency (EPA) and/or the California Air Resources Board (CARB). The hour limitations set forth above do not apply to the Emissions Control System Warranty. Refer to the Engine Emission Control Warranty Statement supplied with your product or contained in the engine manufacturer's documentation for details.

Countries Other than the United States or Canada

Customers who have purchased Toro products exported from the United States or Canada should contact their Toro Distributor (Dealer) to obtain guarantee policies for your country, province, or state. If for any reason you are dissatisfied with your Distributor's service or have difficulty obtaining guarantee information, contact the Toro importer.