



Pro Sweep 5200 Turf Sweeper

Model No. 07066 - 310000001 and up.

Parts Catalog

Ordering Replacement Parts

To order replacement parts, please supply the part number, the quantity, and the description of each part desired.

Understanding Reference Numbers

Each identified part in an illustration has a reference number. The reference number for a part also appears in the parts list, along with other information about the part.

This catalog uses two special reference number formats, one to indicate parts in a service assembly and another to indicate the quantity of a given part in an illustration.

Service Assembly Reference Numbers

Parts in service assemblies have reference numbers in the form a:b. The a represents the reference number of the entire service assembly and the b represents a sequential number unique to each part within the service assembly.

For example, a wheel assembly might be identified by reference number 6, the tire by 6:1, the valve by 6:2, and the wheel by 6:3. When you order the assembly identified by reference number 6, you receive all parts identified by reference numbers 6:1, 6:2, and 6:3. However, you may also order any part individually. Reference numbers of this type appear in illustrations and in part lists.

Reference Numbers Indicating Quantity

In an illustration, if a reference number indicates more than one part, the reference number has the form nX y. The n represents the quantity of the part, the X is the multiplication symbol, and the y represents the reference number.

For example, in an illustration, the reference number 2X 37 means that two of the parts identified by reference number 37 are indicated.

Contents

Description	Page	Description	Page
Main Frame and Axle Assembly 3	Hopper Assembly 13
Trailer Axle Assembly No. 107-1529 4	Hopper Lid and Baffle Assembly 14
Pitch Frame and Cylinder Assembly 5	Hose Assembly 15
Hydraulic Cylinder Assembly No. 107-1310 6	Hydraulic Manifold Block Assembly 16
Saddle Frame Assembly 7	Hydraulic Manifold Assembly No. 112-6752 17
Brush Housing Assembly 8	Tongue Assembly 18
Brush, Motor and Shield Assembly 9	Hydraulic Cylinder Assembly No. 115-8933 19
Hydraulic Motor Assembly No. 105-9455 10	Electrical Assembly 20
Brush Assembly No. 117-8310 11	Remote and Transmitter Assembly 21
Roller Assembly 12	Hydraulic Fitting Assembly 22
		Windrow Assembly 23

Part Description Abbreviations

Part descriptions in this catalog may include the following abbreviations.

AR. as required	HWHTF. hex washer head thread forming
ASM. assembly	HYD. hydraulic
BBC. blade brake clutch	LH. left hand
CARR. carriage	NI. nylon insert
CCW. counter clock wise	NPTF. national pipe thread fine
CW. clockwise	PFH. phillips flat head
DEG. degrees	PPH. phillips pan head
ECM. electronic control module	PPHTF. phillips pan head thread forming
EXT. external	PRH. phillips round head
FH. flat head	PTH. phillips truss head
GA. gauge	PTO. power-take-off
HD. heavy-duty	RH. right hand
HF. hex flange	ROPS. roll-over protection system
HH. hex head	SFH. slotted fillister head
HHF. hex head flange	SHH. slotted hex head
HHFTF. hex head flange thread forming	SHWH. slotted hex washer head
HJ. hex jam	SPH. slotted pan head
HLH. hex lag head	SQH. square head
HOC. height-of-cut	SRH. slotted round head
HSBH. hex socket button head	STD. standard
HSFH. hex socket flat head	TAP. self tapping
HSH. hex socket head	TTH. torx truss head
HWH. hex washer head	

Footnotes

❶ Not illustrated

❷ Not serviced separately

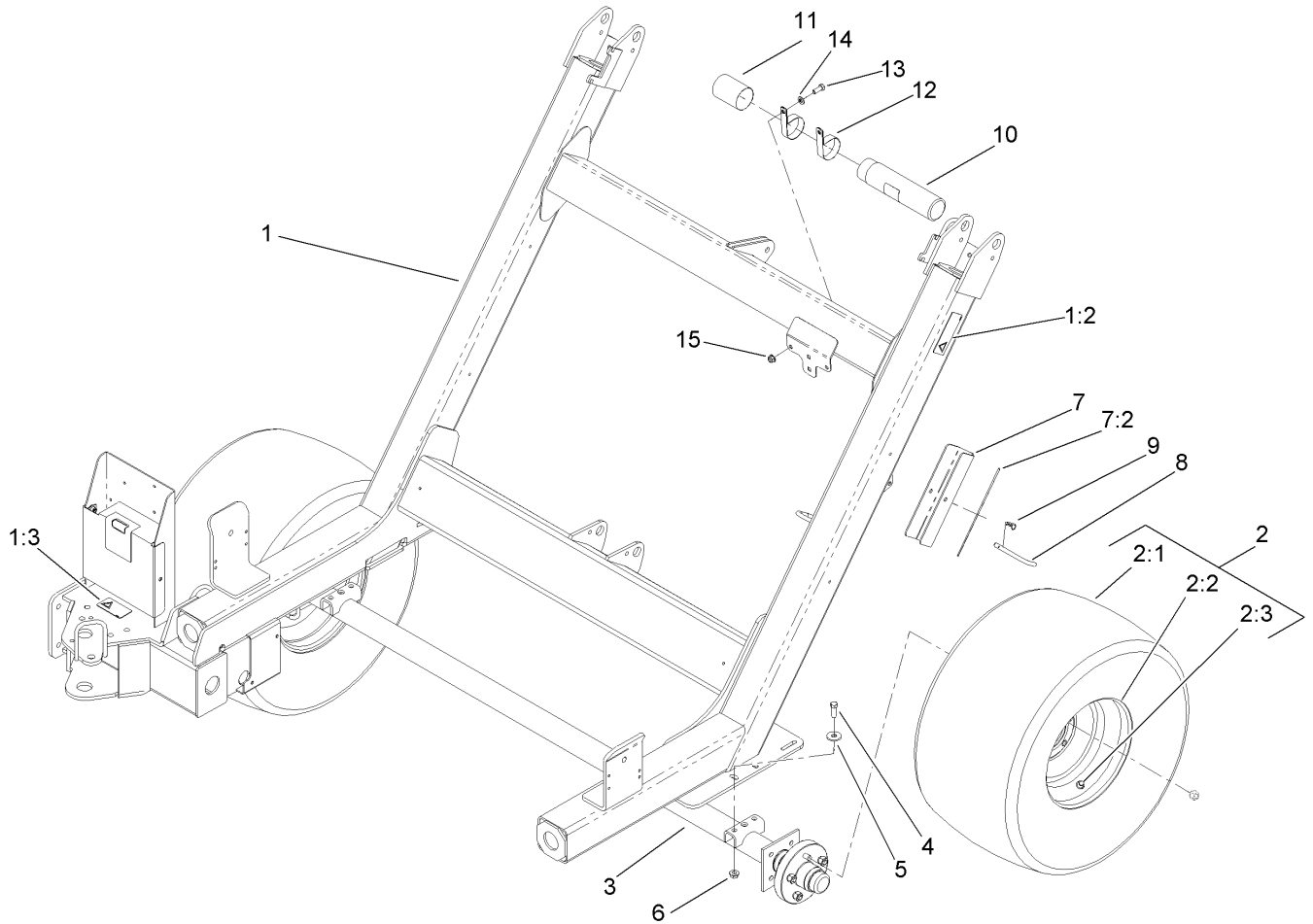

Main Frame and Axle Assembly

Ref	Part No.	Qty.	Description
1	115-8985	1	Frame-Main
1:1	108-0865	2	Decal-Pinchpoint
1:3	108-0866	1	Decal-Pinchpoint
2	112-6819	2	Tire And Wheel ASM
2:1	93-6152	1	Tire
2:2	112-6818	1	Wheel
2:3	232-24	1	Stem-Valve
3	107-1529	1	Trailer Axle ASM
4	324-5	4	Screw-HH
5	63-3340	4	Washer-Support
6	32128-42	4	Nut-HF
7	108-0777	1	Stop-Cylinder
7:2	93-9852	1	Decal-Warning
8	63-7880	1	Pin-Latch, Brake
9	3290-250	1	Pin-Hair
10	104-7050	1	Tube-Manual
11	104-7048	1	Cap-Housing
12	2412-133	2	R-Clamp
13	323-6	2	Screw-HH
14	3256-24	2	Washer-Flat
15	104-8301	2	Nut-Flange, NI

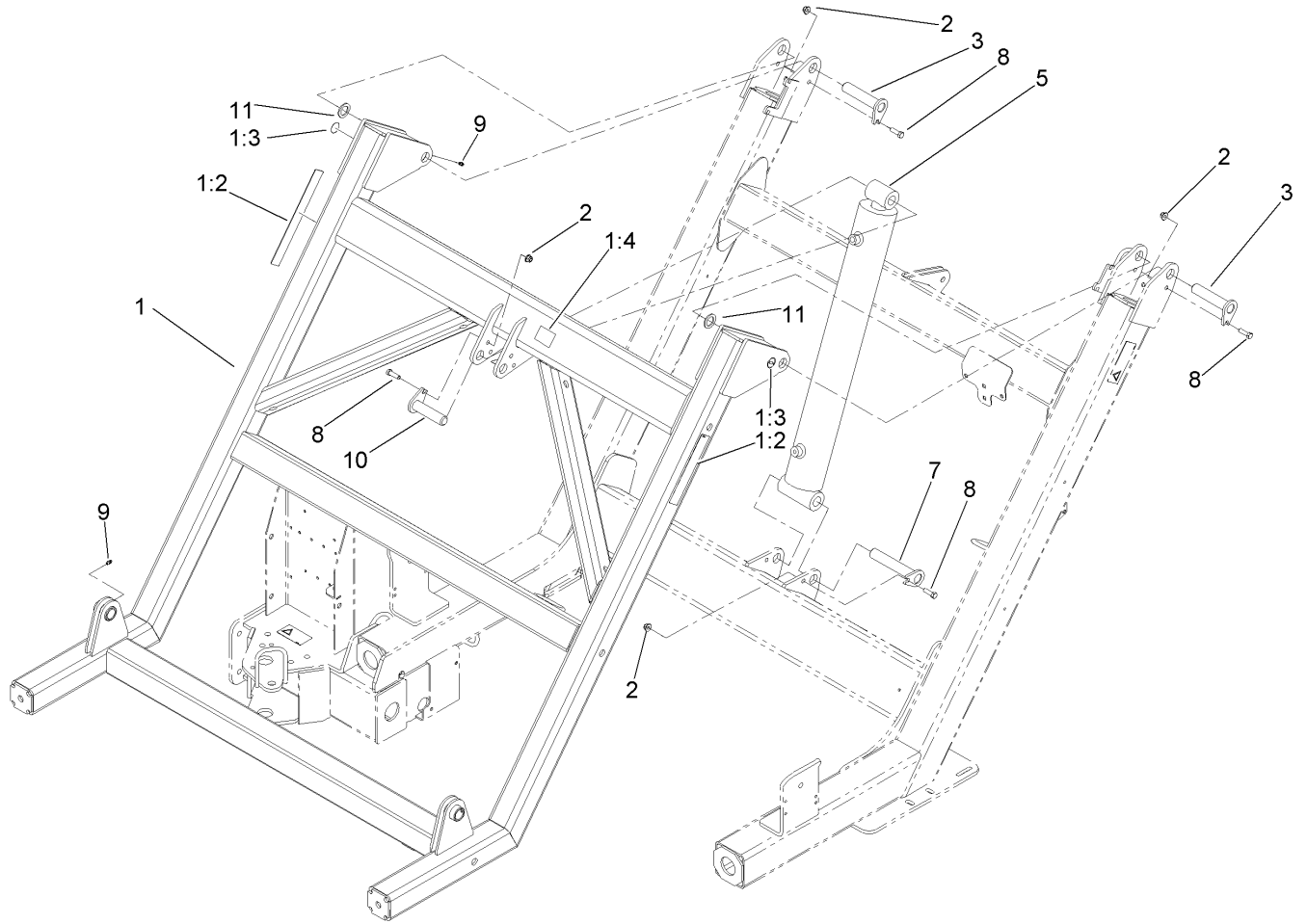

Pitch Frame and Cylinder Assembly

Ref	Part No.	Qty.	Description
1	108-0778	1	Frame-Pitch
1:2	108-0863	2	Decal-Caution, Bystanders (Ce)
1:3	58-6520	2	Decal-Grease
1:4	93-9899	1	Decal-Warning
2	104-8301	4	Nut-Flange, NI
3	107-1258	2	Pin-Flag
5	107-1310	1	Cylinder-HYD
7	108-0669	1	Pin-Flag
8	323-7	4	Screw-HH
9	302-5	4	Fitting-Grease
10	108-0826	1	Pin-Flag
11	92-7845	2	Spacer-Hardened

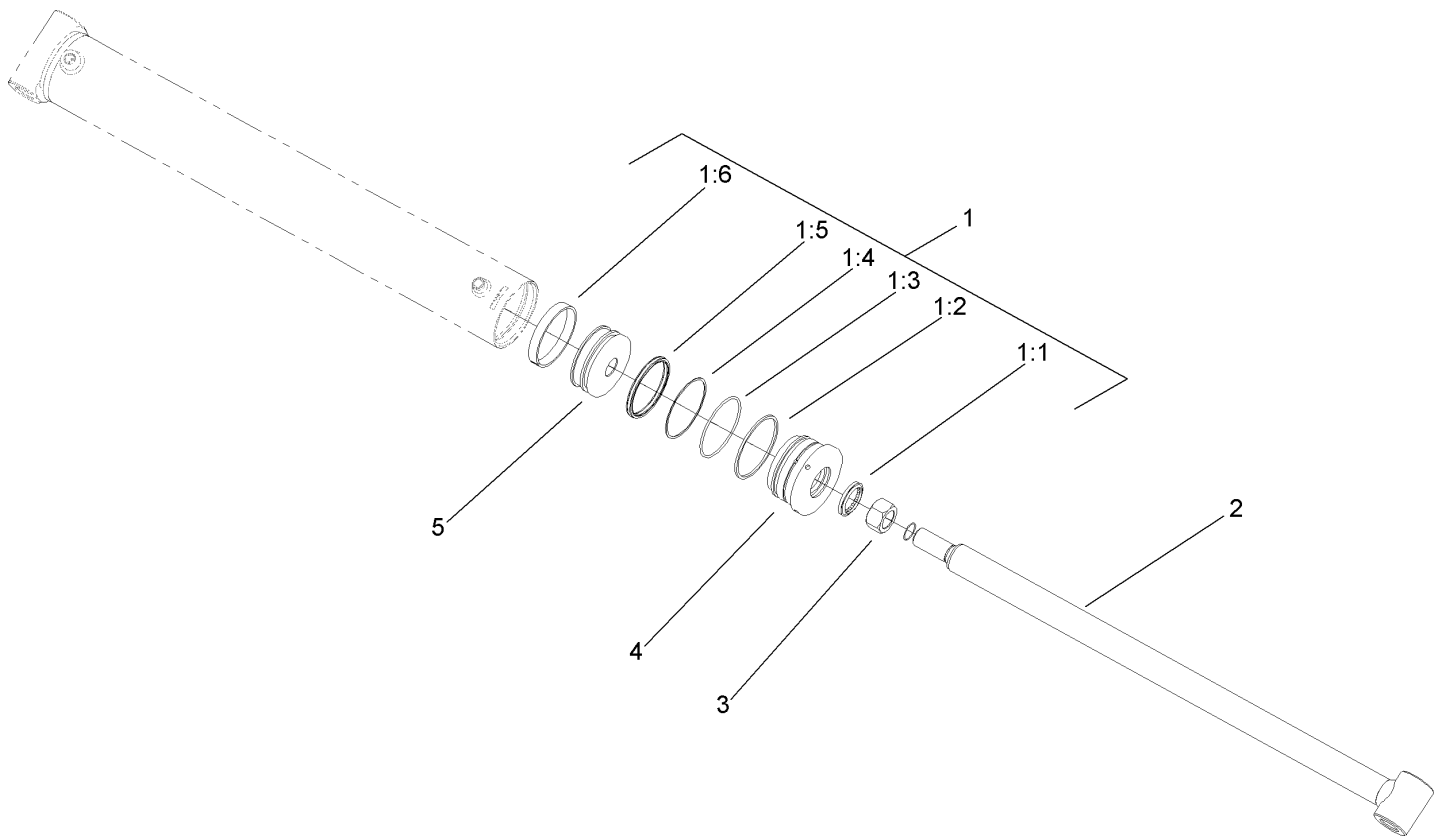

Hydraulic Cylinder Assembly No. 107-1310

Ref	Part No.	Qty.	Description
1	108-2439	1	Seal Kit
② 1:1		1	Wiper
② 1:2		1	O-Ring
② 1:3		1	O-Ring
② 1:4		1	Ring-Back Up
② 1:5		1	Seal
② 1:6		1	Ring-Wear
② 2		1	Rod ASM
② 3		1	Locknut
② 4		1	Head
② 5		1	Piston

--	--	--	--

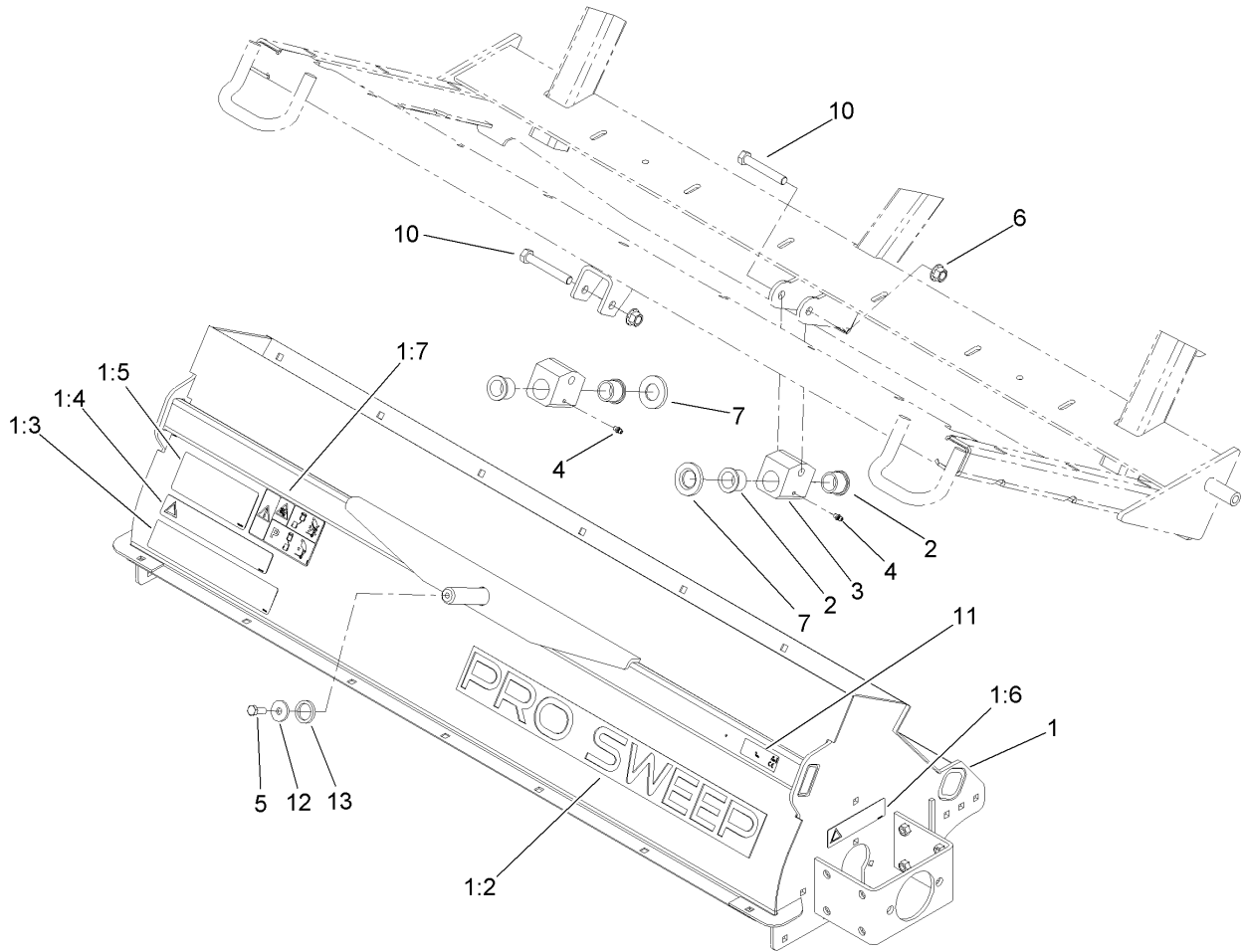

Brush Housing Assembly

Ref	Part No.	Qty.	Description
1	117-8309	1	Brush Housing ASM
1:2	117-8365	1	Decal
1:3	108-0868	1	Decal-Pinchpoint
1:4	108-0862	1	Decal-Warning, Shields
1:5	108-0873	1	Decal-Danger
1:6	108-0870	1	Decal-Warning, Shields
1:7	110-7999	1	Decal-Warning, Offset Lift
2	94-8949	4	Bushing-Flange
3	117-8307	2	Mount-Pivot
4	302-5	2	Fitting-Grease
5	323-6	1	Screw-HH
6	99-5107	2	Nut-Lock
7	117-8302	2	Washer
10	325-14	2	Screw-HH
11	112-6918	1	Decal-Regulatory
12	53-6380	1	Washer-Flat
13	115-5666	1	Spacer-Hardened

--	--	--	--

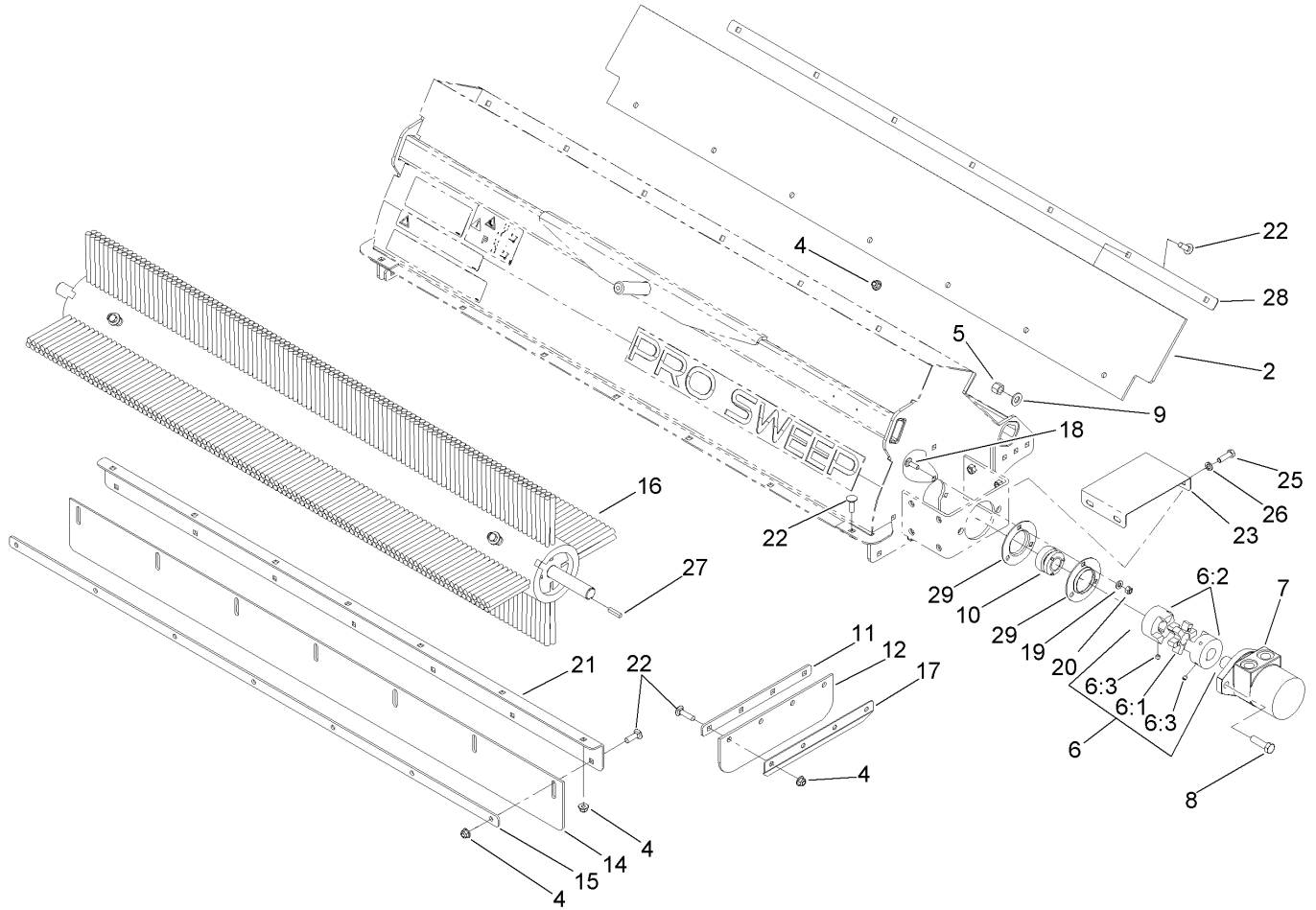

Brush, Motor and Shield Assembly

Ref	Part No.	Qty.	Description
2	108-0686	1	Shield-Rubber, Top
4	104-8301	29	Nut-Flange, NI
5	3296-23	2	Nut-Lock, NI
6	108-0760	1	Coupling-Jaw, Stock
6:1	108-0761	1	Spider-Coupling
6:2	108-0762	2	Coupling-Jaw
6:3	3246-2	4	Screw-Set, HSH
7	105-9455	1	Motor
8	325-7	2	Screw-HH
9	3256-26	2	Washer-Flat
10	115-8975	2	Bearing-Self-Aligning
11	108-0668-03	2	Plate-Skirt, Side
12	115-9093	2	Shield, Rubber-Side
14	115-9092	1	Shield, Rubber-Front
15	108-0667-03	1	Plate-Skirt, Front
16	117-8310	1	Brush ASM
17	107-1439-03	2	Plate-Angle
18	3230-2	6	Bolt-CARR
19	3256-23	6	Washer-Flat
20	3296-29	6	Nut-Lock, NI
21	107-1280-01	1	Angle-Front
22	3231-25	29	Screw-CARR
23	108-0781	2	Cover-Coupler
25	323-6	8	Screw-HH

Ref	Part No.	Qty.	Description
26	3253-21	8	Washer-Lock
27	13-2840	1	Key-Square
28	108-0844-03	1	Plate-Shield, Top
29	107-1474	4	Flange-3 Bolt

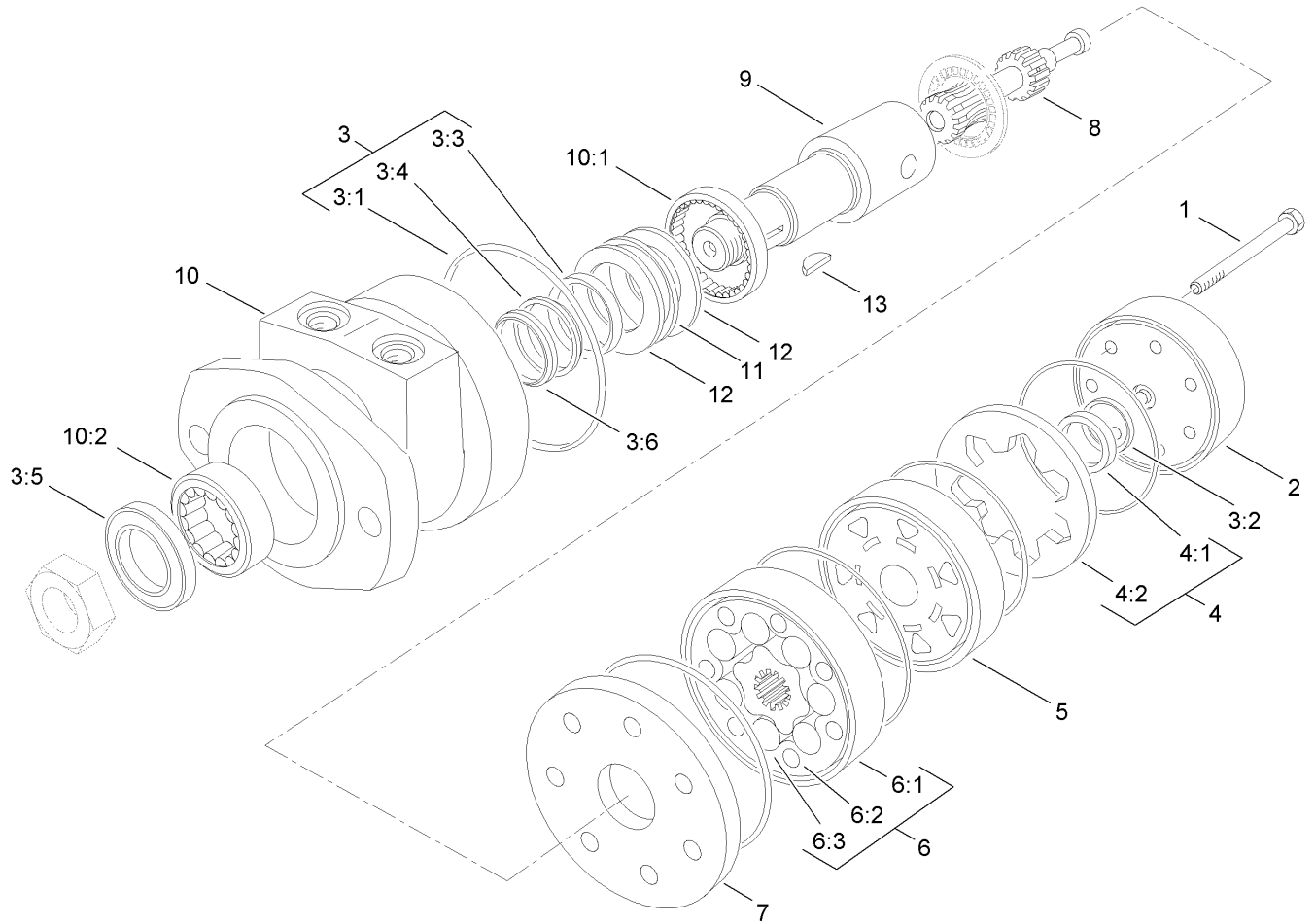

Hydraulic Motor Assembly No. 105-9455

Ref	Part No.	Qty.	Description
1	322-33	5	Screw-HH
2	106-1981	1	Cover-End
3	106-1989	1	Seal Kit
②3:1		6	Seal-Ring
②3:2		1	Seal-Commutator
②3:3		1	Seal-Dirt And Water
②3:4		1	Washer-Backup
②3:5		1	Seal-Shaft
①②3:6		1	Ring-Back Up
4	106-1982	1	Commutator ASM
②4:1		1	Commutator
②4:2		1	Ring-Commutator
5	106-1983	1	Manifold
6	106-1984	1	Rotor Set
②6:1		1	Stator
②6:2		7	Vane
②6:3		1	Rotor
7	106-1985	1	Plate-Wear
8	106-1986	1	Link-Drive
9	106-1987	1	Shaft-Coupling
10	106-1988	1	Housing ASM
②10:1		1	Bearing
②10:2		1	Bearing
②11		1	Bearing-Thrust

Ref	Part No.	Qty.	Description
②12		1	Washer-Thrust
13	106-1990	1	Key-Woodruff

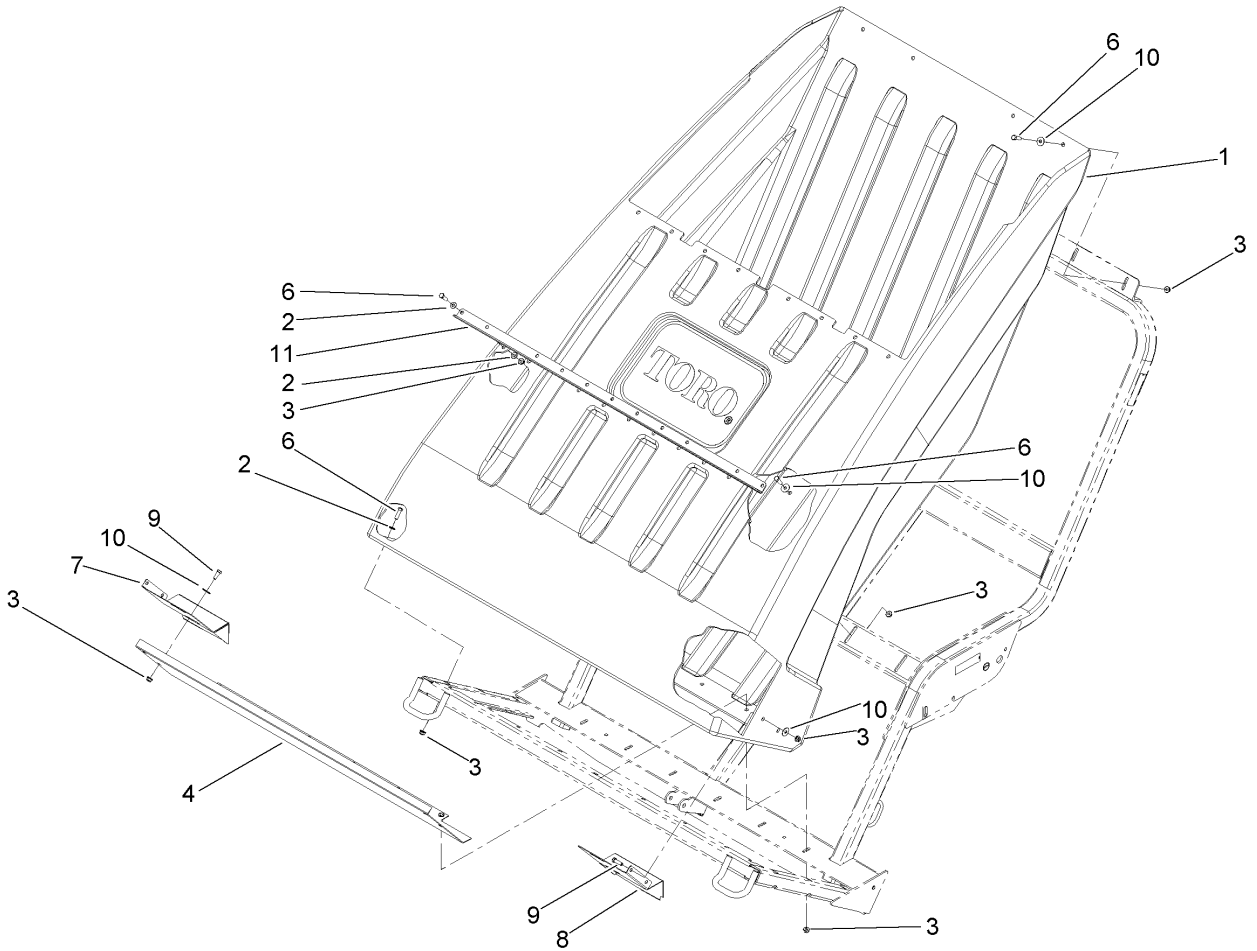

Hopper Assembly

Ref	Part No.	Qty.	Description
1	107-1272	1	Hopper-Dump
2	3256-24	24	Washer-Flat
3	104-8301	45	Nut-Flange, NI
4	107-1225-03	1	Baffle-Hopper
6	323-7	32	Screw-HH
7	107-1462-03	1	Plate-Side, Baffle LH
8	107-1442-03	1	Plate-Side, Baffle RH
9	323-6	8	Screw-HH
10	3256-35	24	Washer-Flat
11	115-9063-03	1	Support-Hopper

--	--	--	--

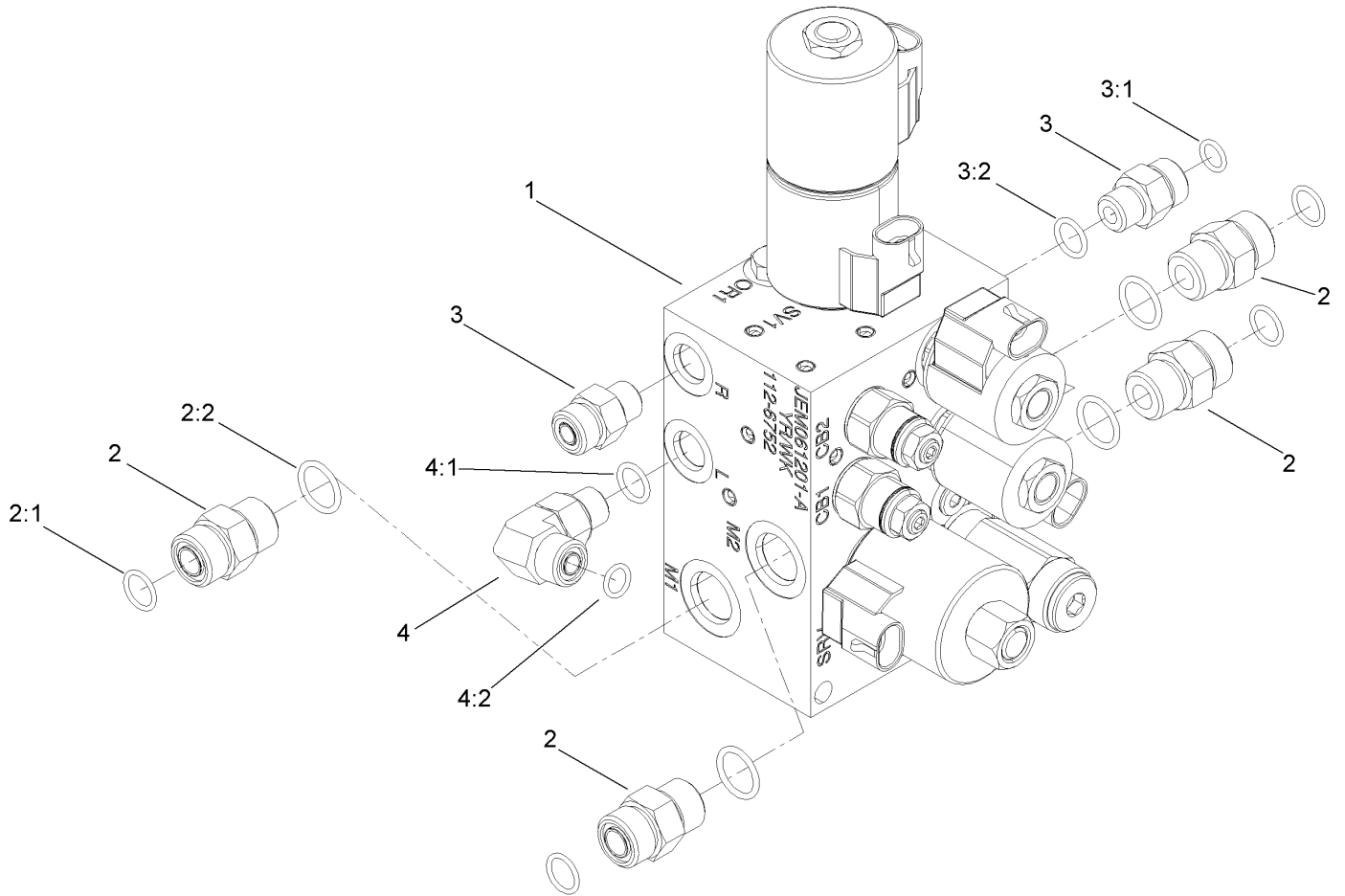

Hydraulic Manifold Block Assembly

Ref	Part No.	Qty.	Description
1	112-6752	1	Manifold-Hydraulic
2	340-4	4	Fitting-HYD, Straight
2:1	237-30	1	O-Ring
2:2	237-79	1	O-Ring
3	340-2	2	Fitting-HYD, Straight
3:1	237-22	1	O-Ring
3:2	237-42	1	O-Ring
4	340-77	1	Fitting-HYD, 90 DEG
4:1	237-22	1	O-Ring
4:2	237-42	1	O-Ring

--	--	--	--

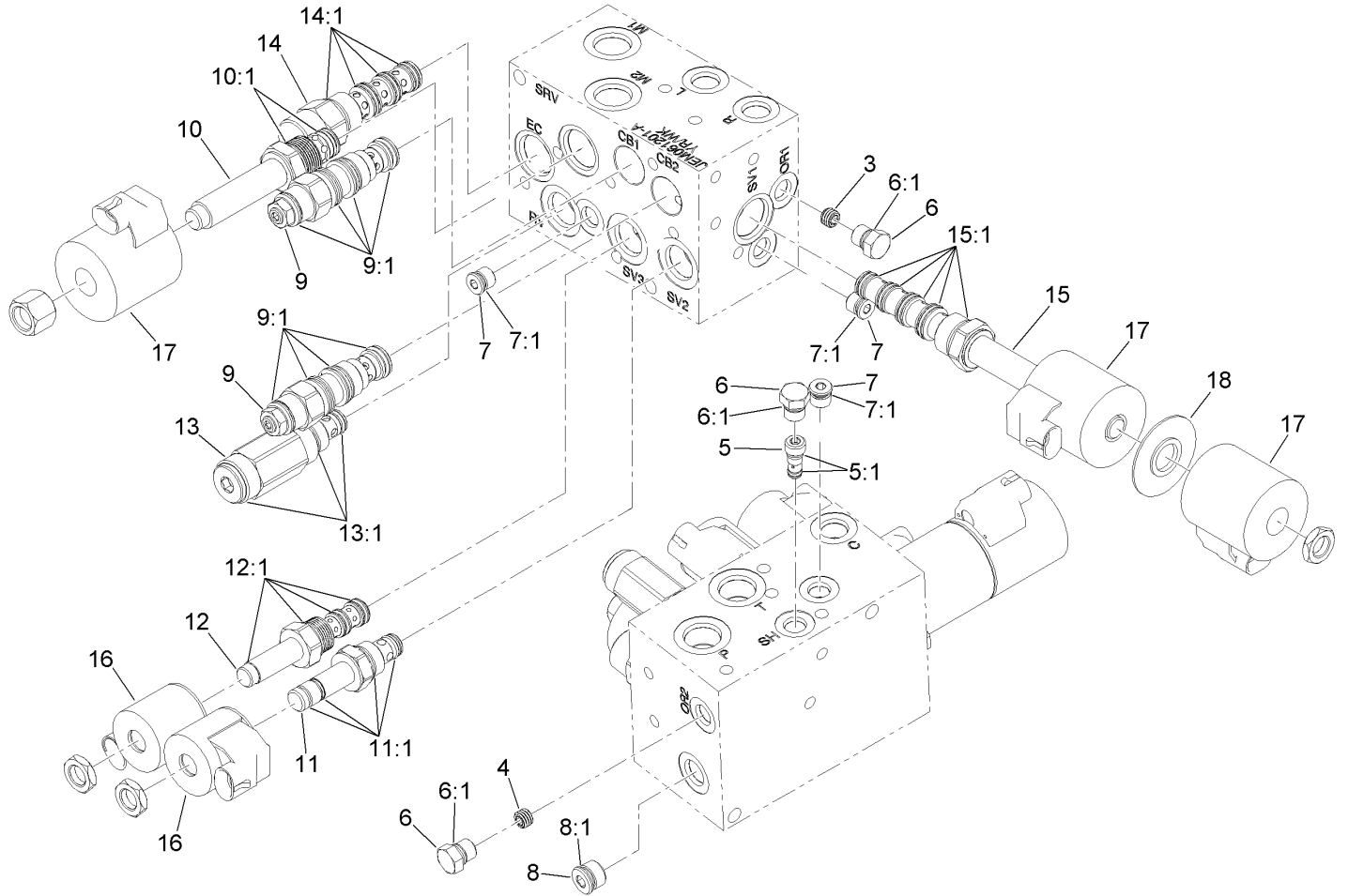

Hydraulic Manifold Assembly No. 112-6752

Ref	Part No.	Qty.	Description
3	107-7525	1	Plug-Orifice, .050
4	112-9202	1	Orifice-Flow, Control
5	117-8313	1	Shuttle-Load
5:1	117-7597	1	Seal Kit
6	117-0115	1	Plug-Hex, Zero Leak
6:1	237-78	1	O-Ring
7	353-990	1	Plug
7:1	237-78	1	O-Ring
8	106-1026	1	Plug-HYD
8:1	237-42	1	O-Ring
9	114-5082	2	Valve-Balance, Counter
9:1	114-5083	1	Seal Kit
10	110-8768	1	Valve-Relief, Solenoid
10:1	110-6316	1	Seal Kit
11	107-7516	1	Valve-Solenoid
11:1	105-9156	1	Seal Kit
12	106-1995	1	Valve-3 Way
12:1	110-8773	1	Seal Kit
13	117-8312	1	Valve-Relief
13:1	105-9156	1	Seal Kit
14	117-8314	1	Compensator-Pressure
14:1	110-8908	1	Seal Kit
15	117-8311	1	Valve-Solenoid
15:1	117-7596	1	Seal Kit

Ref	Part No.	Qty.	Description
16	105-9333	2	Coil-12Vdc
17	110-2630	3	Coil-12Vdc
18	117-8316	1	Spacer-E Coil

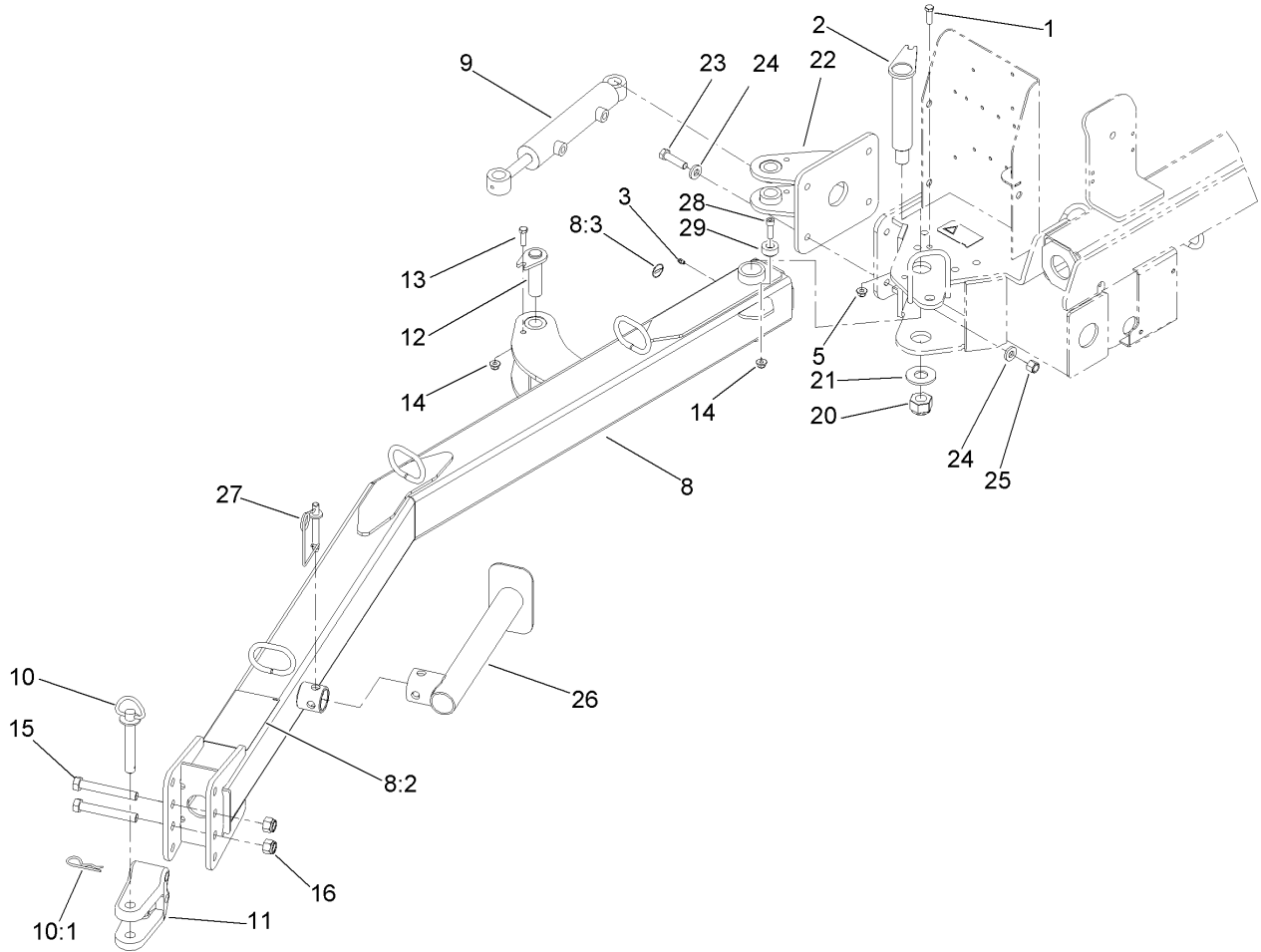

Tongue Assembly

Ref	Part No.	Qty.	Description
1	323-7	1	Screw-HH
2	115-2927	1	Pin ASM
3	302-5	1	Fitting-Grease
5	104-8301	1	Nut-Flange, NI
8	115-8991	1	Tongue-Hitch
8:2	108-0861	1	Decal-Danger, Sweeper
8:3	58-6520	1	Decal-Grease
9	115-8933	1	Hydraulic Cylinder ASM
10	13-6200	1	Pin-Hitch, Pointed
10:1	3290-343	1	Pin-Hair
11	47-3550	1	Hitch-Clevis
12	115-8934	2	Pin ASM
13	323-7	2	Screw-HH
14	104-8301	3	Nut-Flange, NI
15	327-23	2	Screw-HH
16	3296-53	2	Nut-Lock, NI
20	104-2024	1	Nut-Lock
21	112-4953	1	Washer-Plain
22	115-9010-01	1	Bracket ASM
23	325-8	4	Screw-HH
24	107-3395	4	Washer-Hardened
25	3296-23	4	Nut-Lock, NI
26	117-8325-01	1	Stand ASM
27	99-5610	1	Pin

Ref	Part No.	Qty.	Description
28	3274-1	1	Screw-HSH
29	117-8533	1	Plate-Sensing

