

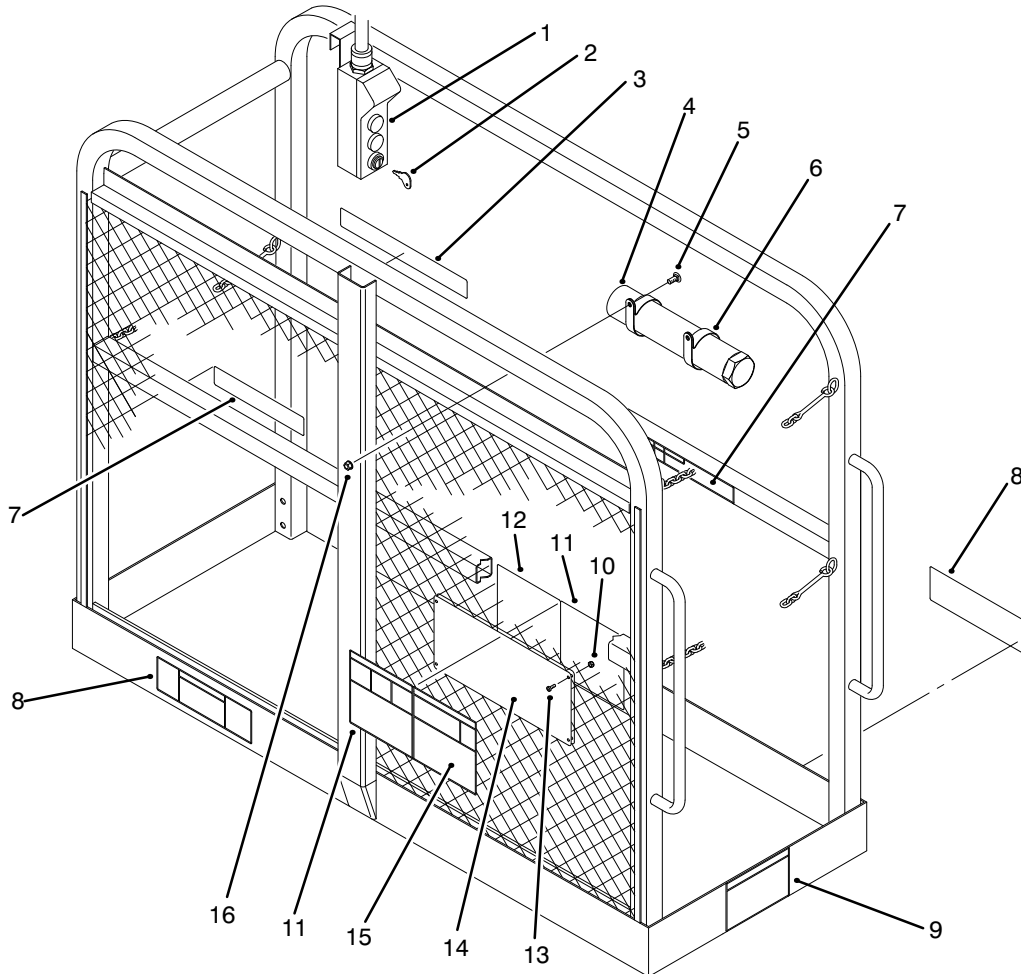

MODEL NO. 07344-40001 & UP

**PARTS
CATALOG**
**1/3 PLATFORM LIFT
FOR WORKMAN VEHICLE**

T-1937

DECK ASSEMBLY

Ref. No.	Part No.	Description	No. Used
1	93-3712	Push Button Sta. w/Cord	1
2	92-9145	Key & Switch	1
3	93-3705	Decal - Danger	1
4	74-0720	Tube - Manual	1
5	3230-18	Bolt - Carriage	2
6	2412-133	R-Clamp	2
7	93-3707	Decal - Danger	2
8	93-3706	Decal - Danger	2
9	93-3701	Decal - Danger	1

Ref. No.	Part No.	Description	No. Used
10	3296-2	Nut - Lock	4
11		Decal - Danger	2
12		Decal - Danger	1
13	3250-12	Screw - Pan Phillips Head	4
14	93-3738	Plate - Kit, Decals (Incl. Ref. #10-15)	1
15		Decal - Danger	1
16	32128-20	Nut - Flange Head	2

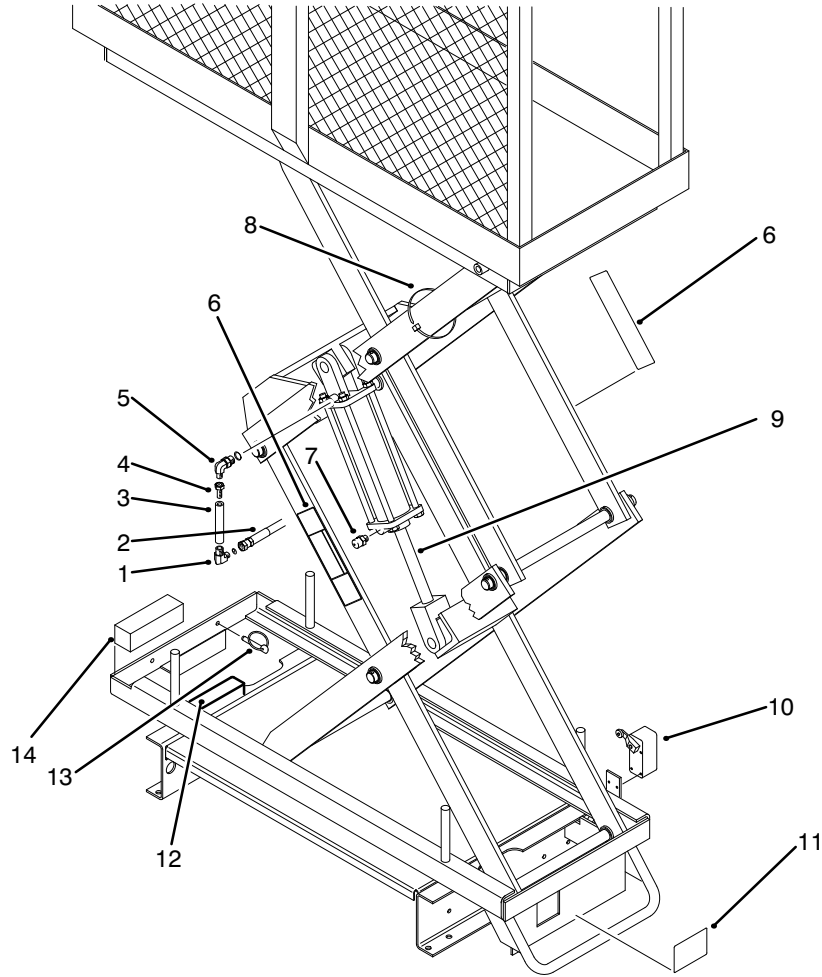

T-1938

ARM AND CYLINDER ASSEMBLY

Ref. No.	Part No.	Description	No. Used
1	93-3746	Adaptor - Fitting	1
2	93-3735	Assembly - Hose	1
3	93-3733	Control - Flow, Fixed	1
4	93-3747	Fitting - Reducer, Hex.	1
5	93-3749	Adaptor - Fitting	1
6	93-3706	Decal - Danger	2
7		Breather (w/Ref. #9)	1
8	250-5	Tie - Cable	7

Ref. No.	Part No.	Description	No. Used
9	93-3734	Cylinder - Hydraulic (Incl. Ref. #7)	1
10	93-3713	Limit Switch w/Lever	1
11	93-3711	Decal - Important	1
12	93-3708	Decal - Danger	1
13	93-3736	Pin - Quick Release	1
14		Block - Wood (1-1/2 x 1-7/8 x 7")	2

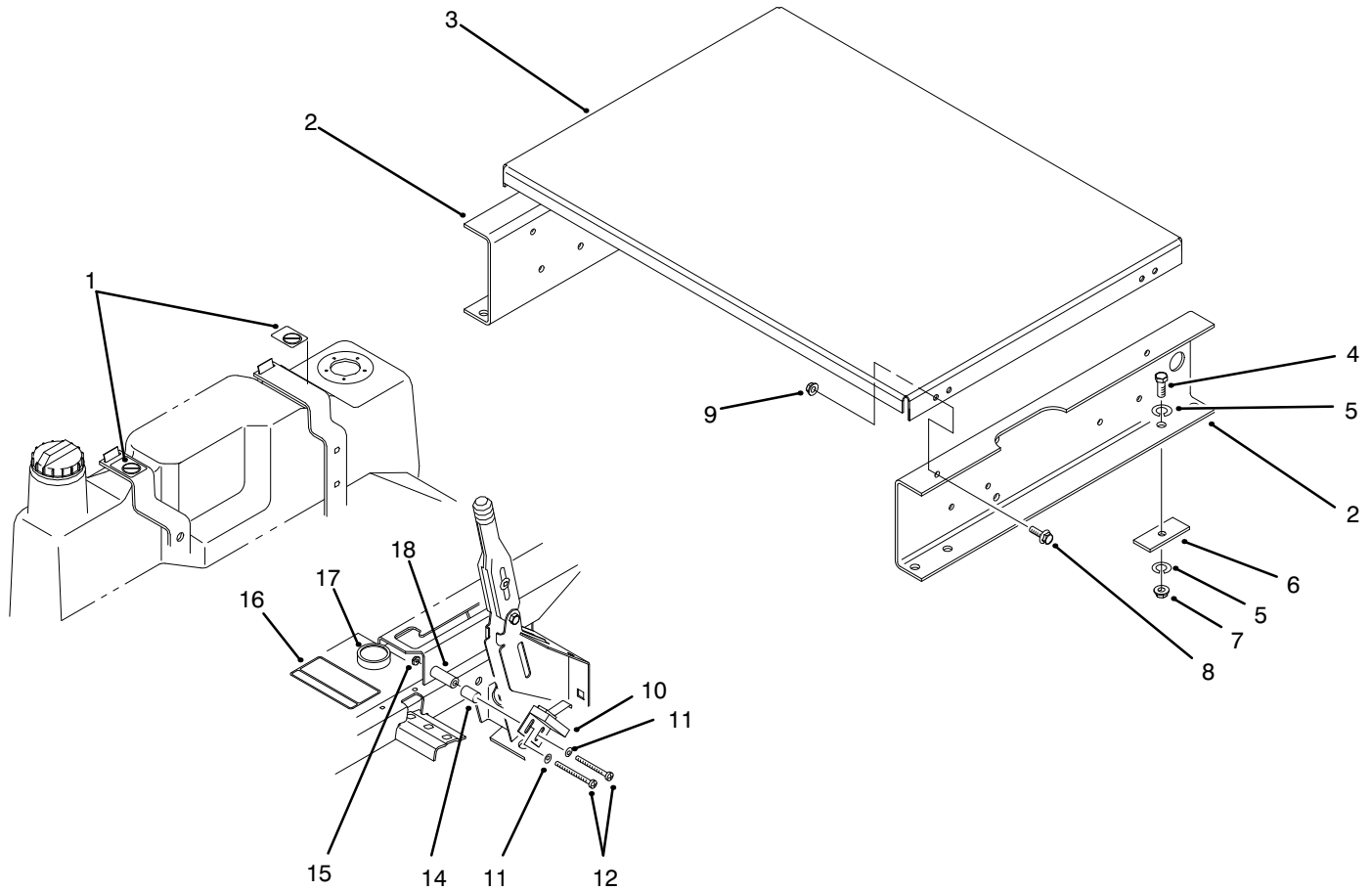

T-1939

BRAKE SWITCH AND COVER ASSEMBLY

Ref. No.	Part No.	Description	No. Used
1	93-3709	Decal - No Step	2
2		Channel - Base	2
3	93-3737	Cover - Base	1
4	323-6	Screw - Cap Hex. Head	4
5	3253-5	Washer - Lock	4
6		Plate - Reinforcing	2
7	32128-29	Nut - Flange Head	2
8	3234-29	Screw - Flange, Hex. Head	4
9	32128-35	Nut - Flange Head	4
10	93-3722	Switch - Brake, Parking	1

Ref. No.	Part No.	Description	No. Used
11	3256-77	Washer - Flat	2
12	32105-14	Screw - Pan Phillips Head	2
14		Spacer - Short	1
15	3296-12	Nut - Lock	2
16	93-3710	Decal - Warning	1
17	93-3726	Level - Circular w/Adhesive	1
18		Spacer - Long	1
*	93-3727	Kit - Brake, Parking (Incl. Ref. #10-15, & 18)	1
*	250-5	Tie - Cable	2

*Not Illustrated

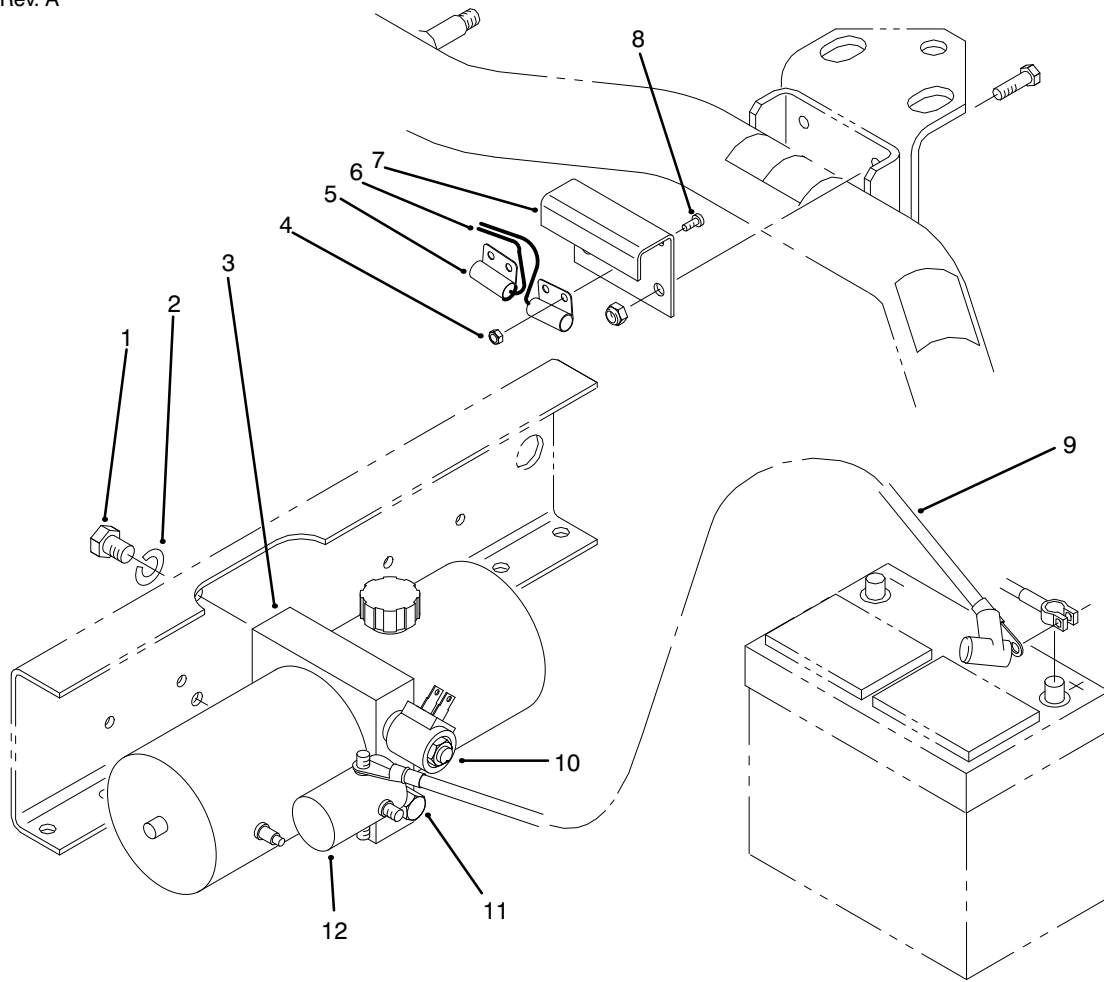

T-1940

POWER PACK ASSEMBLY

Ref. No.	Part No.	Description	No. Used
1	323-3	Screw - Cap Hex. Head	2
2	3253-5	Washer - Lock	2
3	93-3732	Power Unit - DC Hydraulic	1
4	3296-12	Nut - Lock	4
5	93-3724	Switch - Mercury	2
6	93-3723	Kit - Switch, Leveling (Incl. Ref. #4-11)	1
7		Bracket - Switch, Level	1
8	3250-12	Screw - Pan Phillips Head	4
9	93-3725	Cable - Positive, w/Boot	1

Ref. No.	Part No.	Description	No. Used
*	93-3745	Cable - Negative, Battery	1
10	92-9144	Valve - Solenoid W/O Ride	1
11	93-3748	Adaptor - Fitting	1
12	94-2864	Relay Switch Kit	1
*	93-3718	Kit - Wire Harness, Front	1
*	63-7590	Relay	1
*	93-3721	Relay	1
*	93-7315	Horn - Warning	1
*	250-5	Tie - Cable	3

*Not Illustrated

ELECTRICAL SCHEMATIC

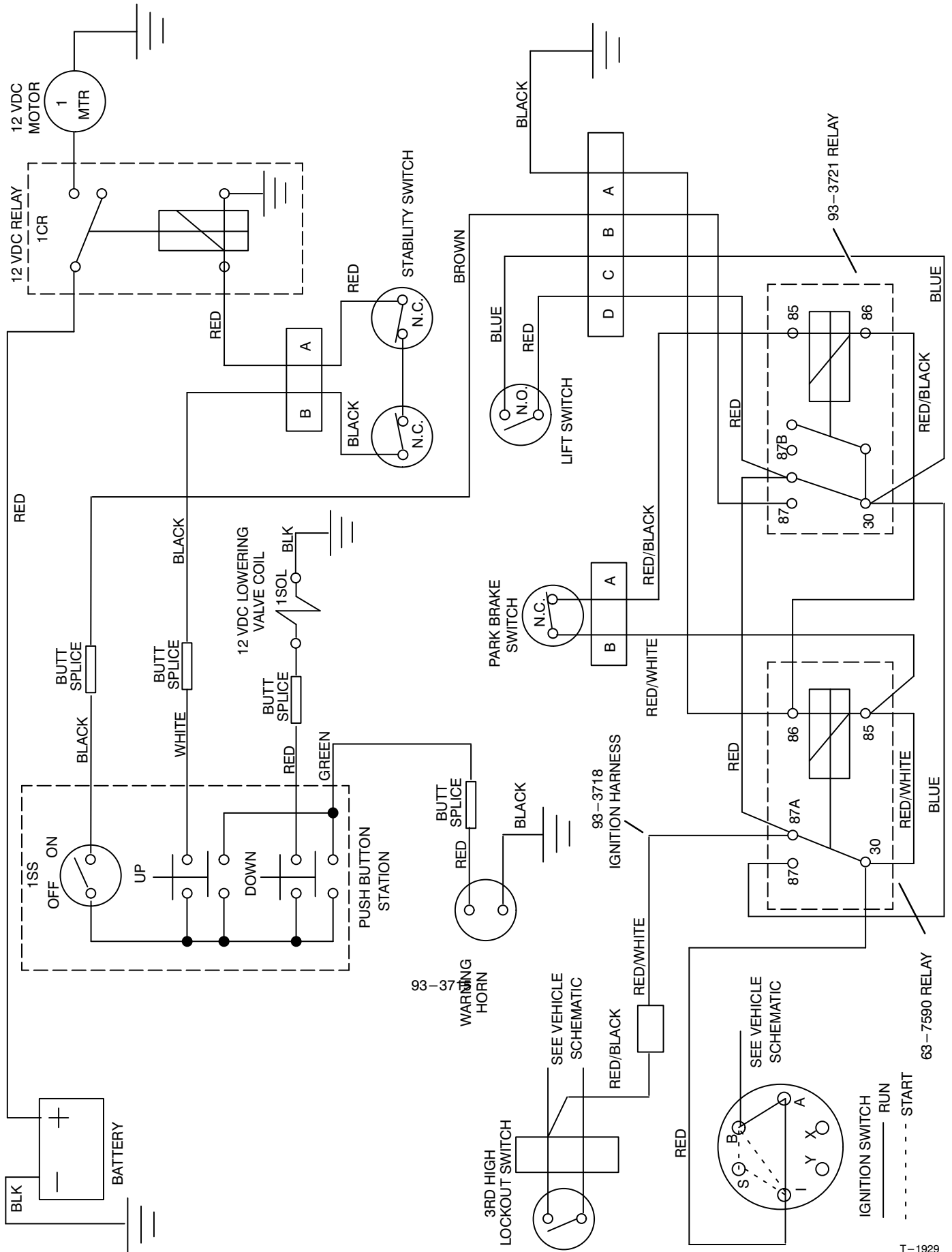

HYDRAULIC SCHEMATIC

