

Char-Lynn®
Hydraulic Motor

No. 7-124
July, 1999

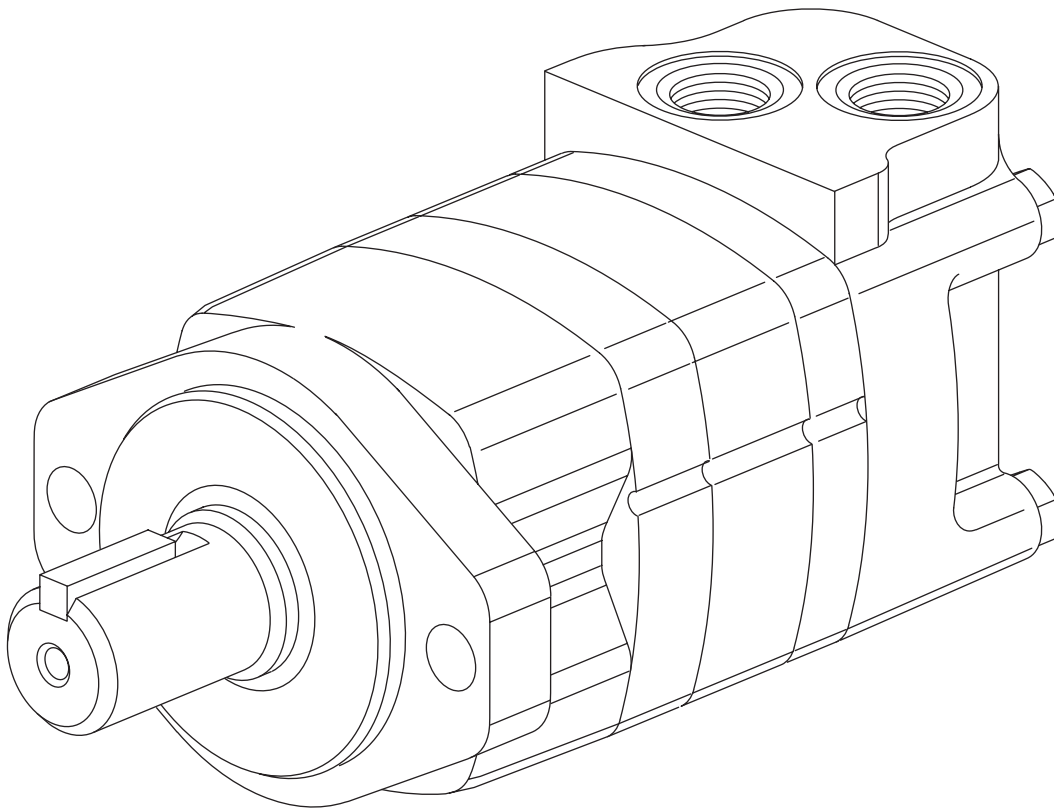

Repair Information



2000 Series
Disc Valve Geroler Motor

006

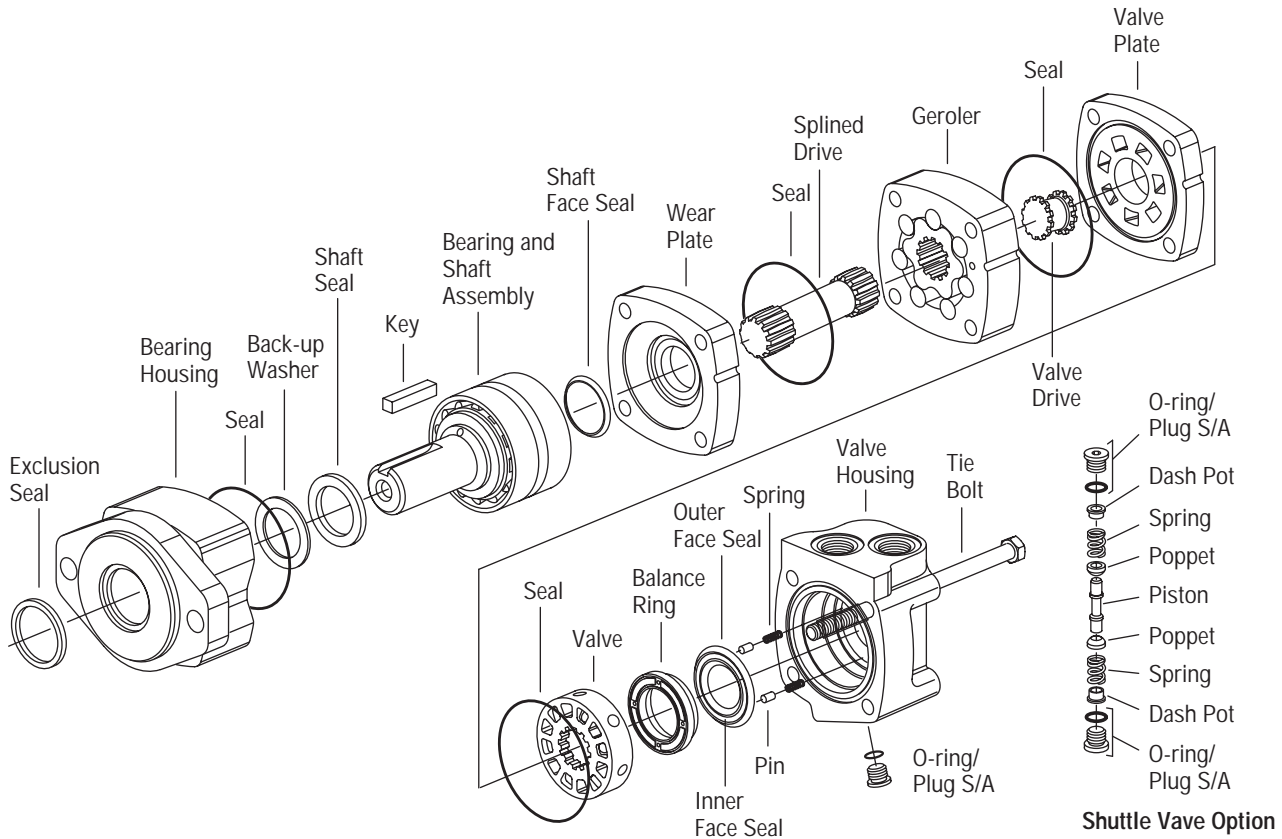

Tools required for disassembly and reassembly.

- Torque wrench 57Nm [500 lb-in] capacity
- 300-450 [12-16]* breaker bar
- 9/16 socket
- Small screwdriver 150-200 x 6,5 [6-8 x 1/4] blade
- 3/16 Allen wrench
- Press

* Unless indicated otherwise, measurements are given in mm [inches]

** Shaft seal installation tool (600496)

** Bullet (600465) for 1 diameter shafts

The following tools are not necessary for disassembly and reassembly, but are extremely helpful.

Alignment studs (2)

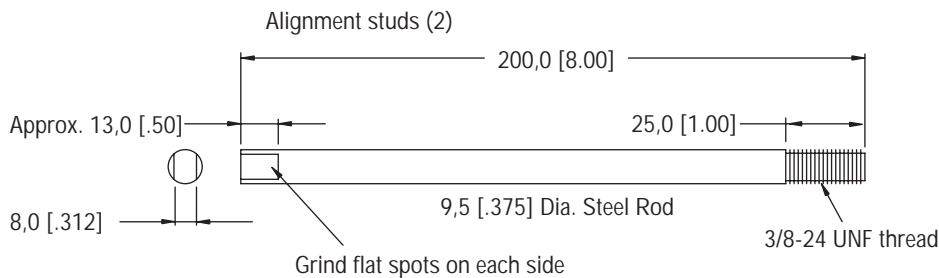

Disassembly

Cleanliness is extremely important when repairing a hydraulic motor. Work in a clean area. Before disconnecting the lines, clean the port area of the motor thoroughly. Use a wire brush to remove foreign material and debris from around the exterior joints of the motor. Check the shaft and key slot, remove all nicks, burrs or sharp edges that might damage the bearing housing seals when installing the shaft and bearing assembly. Before starting the disassembly procedures, drain the oil from inside the motor.

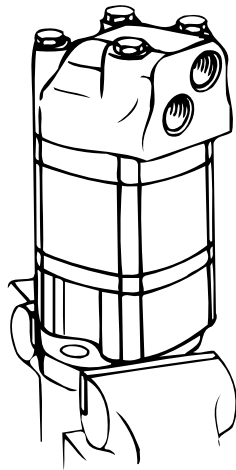

Figure 1

1 Place the motor in a vise with the output shaft down. Clamp across the mounting flange of the motor not the housing. Excessive clamping pressure will cause distortion. When clamping, use some protective device on the vise, such as special soft jaws, pieces of hard rubber or board.

Although not all drawings show the motor in a vise, we recommend that you keep the motor in the vise during disassembly and reassembly. Follow the clamping procedures explained throughout the manual.

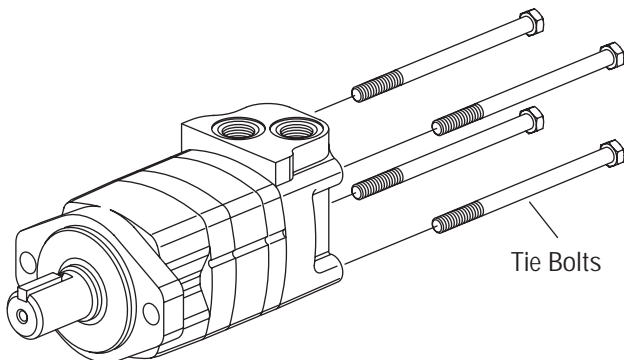

Figure 2

2 Remove 4 bolts from motor.

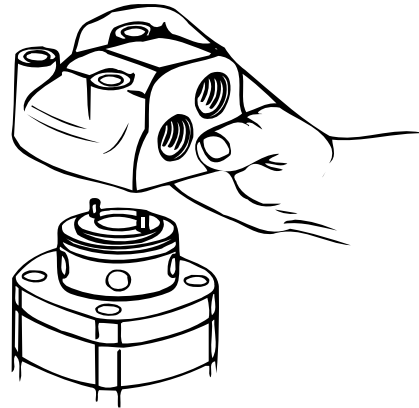

Figure 3

3 Lift valve housing straight up. If done carefully the pins, springs, balance ring assembly, and valve will remain on the valve plate.

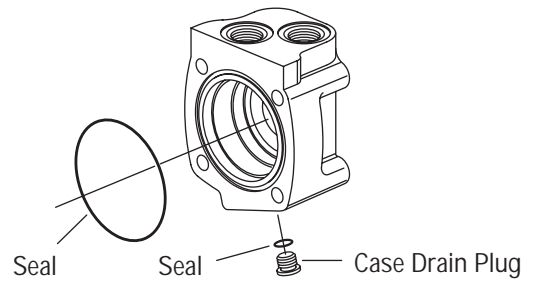

Figure 4

4 Carefully remove 76,0 [3.00] diameter seal from valve housing.

5 Remove case drain plug—with seal, from valve housing.

6 Remove 2 pins and 2 springs from balance ring assembly, see Figure 5.

Disassembly

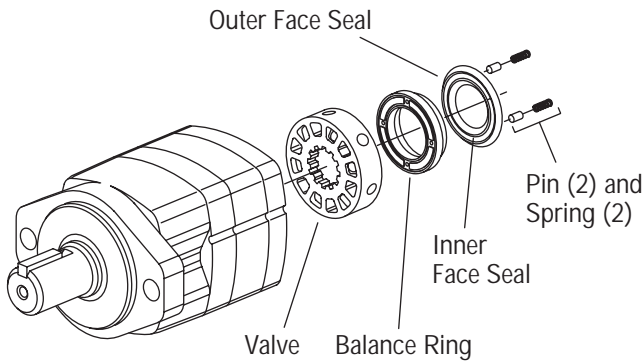

Figure 5

- 7 Remove balance ring assembly.
- 8 Remove inner and outer face seals from balance ring.
- 9 Remove the valve.

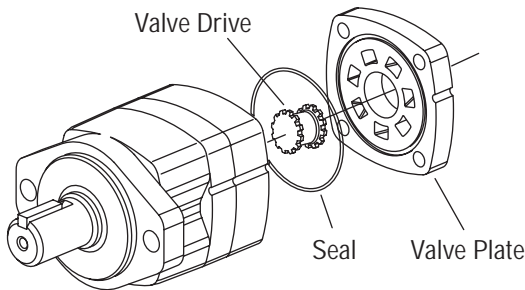

Figure 6

- 10 Remove the valve plate.
- 11 Remove the 76,0 [3.00] diameter seal from valve plate.
- 12 Remove the valve drive.

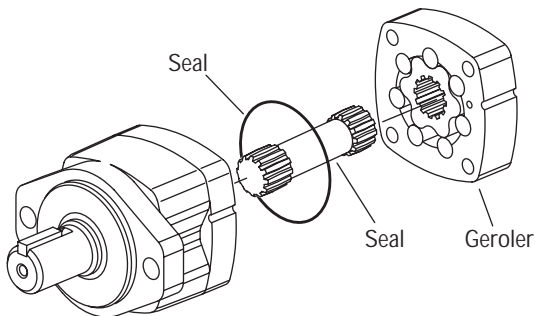

Figure 7

- 13 Remove the Geroler. Be sure to retain the rollers in the outer ring if they are loose.
- 14 Remove the drive.

- 15 Remove the 76,0 [3.00] diameter seal from wear plate, see Figure 7.

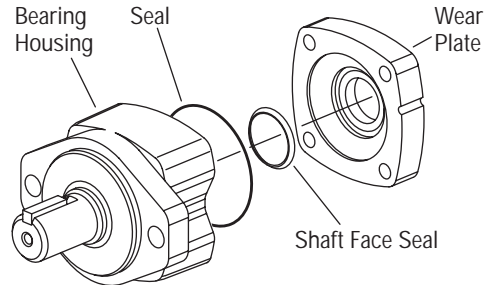

Figure 8

- 16 Remove the wear plate.
- 17 Remove the shaft face seal from the wear plate.
- 18 Remove the 76,0 [3.00] diameter seal from bearing housing.

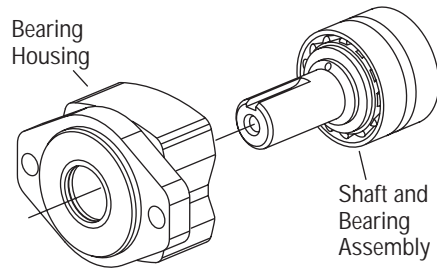

Figure 9

- 19 You may need a press to remove shaft and bearing assembly from bearing housing. (Key must be removed before removing shaft.)

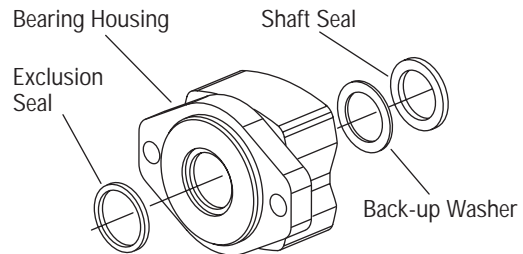

Figure 10

- 20 Use a small screwdriver to remove shaft seal, back-up washer and exclusion seal from bearing housing, see Figure 10. Do not damage bore of housing.

Note: Individual parts of shaft and bearing assembly are not sold separately. Replace as a unit.

Reassembly

Check all mating surfaces. Replace any parts that have scratches or burrs that could cause leakage. Clean all metal parts in clean solvent. Blow dry with air. Do not wipe dry with cloth or paper towel because lint or other matter can get in the hydraulic system and cause damage. Do not use a coarse grit or try to file or grind these parts. Check around the keyway and chamfered area of the shaft for burrs, nicks or sharp edges that can damage the seals when reassembling the bearing housing.

Note: Lubricate all seals (prior to installation) with petroleum jelly such as Vaseline. Use new seals when reassembling this motor. Refer to parts list (6-129) for proper seal kit number.

21 Use a press to install exclusion seal in outer bore of bearing housing. Lip of seal must face outward. See Figure 11. If a press is not available use a plastic or rubber hammer, being careful not to damage or cock seal in the bore.

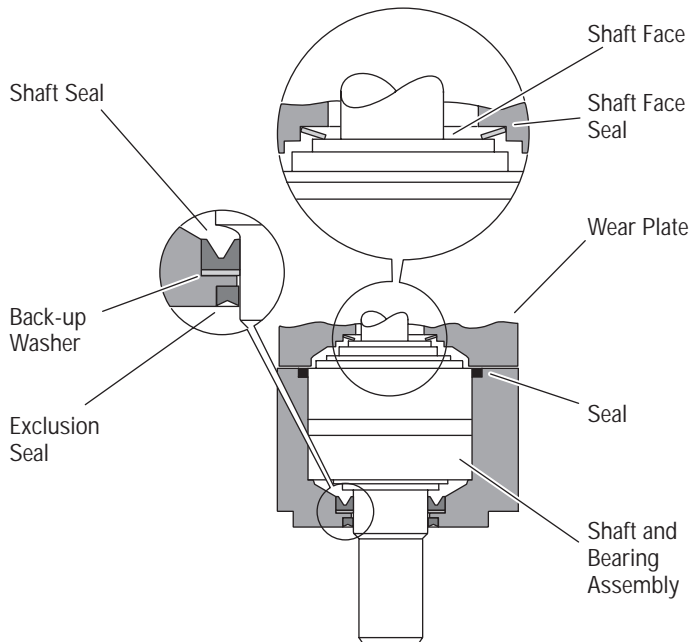

Figure 11

22 Place back-up washer into seal bore. Place shaft seal onto installation tool (600496) and press seal into seal bore of the housing.

23 Clamp housing in vise, see Figure 1.

24 Place protective bullet (see note below) over shaft. Apply petroleum jelly to inside diameter of dust and shaft seal. You may need a press to install shaft and bearing assembly. Do not distort shaft seal. Damage to this seal will cause leakage.

Note: Bullet (600465), for 1 inch dia. shafts, available— by special order. Use tape over other shafts to prevent cutting the seals.

25 Apply petroleum jelly to the 76,0 [3.00] diameter seal. Install seal into the bearing housing.

26 Alignment studs can be very helpful in reassembly of the motor. See special tool listing page 2. If you use studs, install 2 studs diagonally opposed in the bearing housing.

27 Install the shaft face seal in the wear plate as shown in Figure 11. Do not distort seal.

28 Install the wear plate, see Figure 11.

29 Apply a light film of petroleum jelly to the 76,0 [3.00] diameter seal and install seal in the wear plate.

30 Install the drive into the output shaft.

31 Align the notch on the outside of the Geroler with the notch on the wear plate. Install the Geroler against the wear plate. Be sure to retain the rollers in the outer ring if they are loose.

32 Install the valve drive in the Geroler.

Note: Installation at this time involves 3 steps in the timing of the motor. Timing determines the direction of rotation of the output shaft. Timing parts include:

1. Geroler
2. Valve Drive
3. Valve Plate
4. Valve

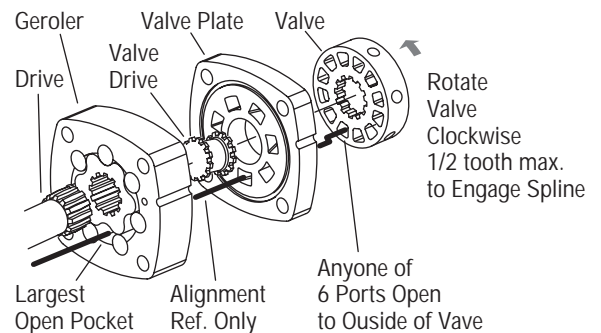

Figure 12 Timing Alignment

Timing Step # 1 — Locate the largest open pocket in the Geroler and mark it on the outside edge of the Geroler.

33 Apply a light film of petroleum jelly to the 76,0 [3.00] diameter seal. Install seal in groove of valve plate.

Reassembly

34 Align the notch on the outside of the valve plate with the notch on the Geroler as shown in Figure 12.

Timing Step # 2 — Locate the slot opening in the valve plate which is in line with the largest open pocket of the Geroler.

Timing Step # 3 — Locate any one of the side openings of the valve and align this opening with the open slot of the valve plate that is in line with the largest open pocket of the Geroler. Install the valve by rotating it clockwise until the spine teeth engage (1/2 spine tooth max.). This will provide the proper rotation when pressurized as shown in Figure 13.

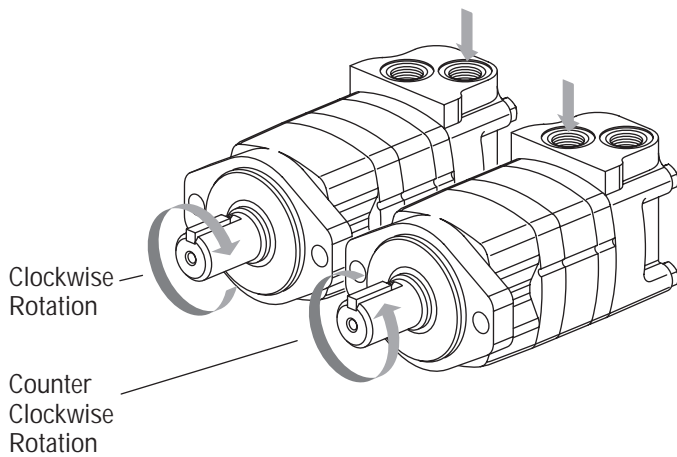

Figure 13

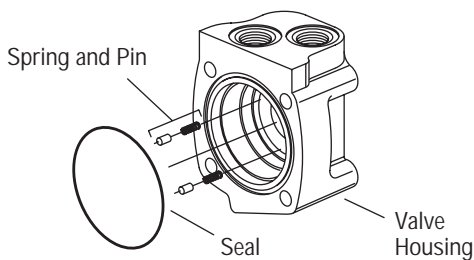

Figure 14

35 Install 2 springs and 2 pins in the holes located in the bore of the valve housing, as shown in Figure 14.

36 Apply a light film of petroleum jelly to the 76,0 [3.00] diameter seal. Install seal in the valve housing.

37 Apply petroleum jelly to inner and outer face seals. Install seals on balance ring as shown in Figure 15.

Important: Install face seals in the positions shown in Figure 15, or the motor will not operate properly. Do not force or bend the face seals. Any damage to these seals will affect the operation of the motor.

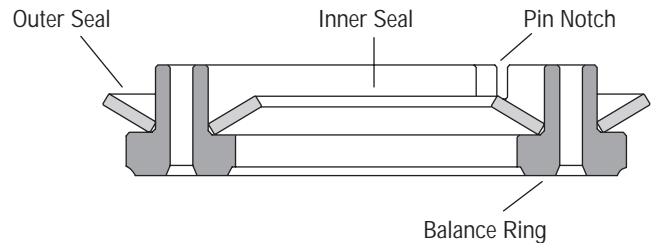

Figure 15

38 Align pin notches in balance ring with pins in bore of valve housing. Install balance ring assembly in valve housing.

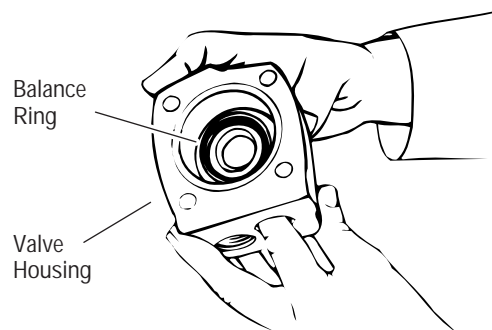

Figure 16

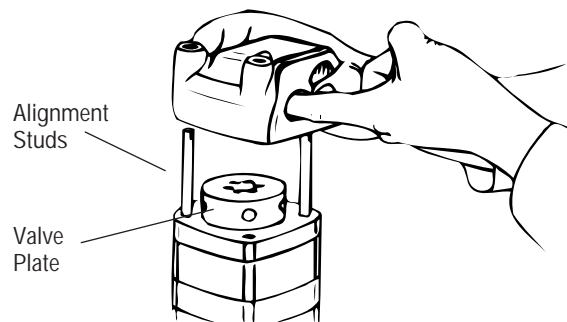

Figure 17

39 Insert your finger through port of valve housing. Apply pressure to side of balance ring as shown in Figure 16. Hold ring in position until valve housing is in place against valve plate (see Figure 17).

Note: After installing the valve housing on the valve plate check for proper placement. Push down on the valve housing. You should get a slight spring action.

Reassembly

40 Install tie bolts. If you use alignment Studs, install 2 bolts opposite the studs. Finger tighten the bolts. Remove the alignment studs and replace with the two remaining bolts. Torque all four bolts alternately to 50 Nm [450 lb-in].

41 Install seal on case drain plug then install in valve housing. Torque to 6 Nm [50 lb-in.]

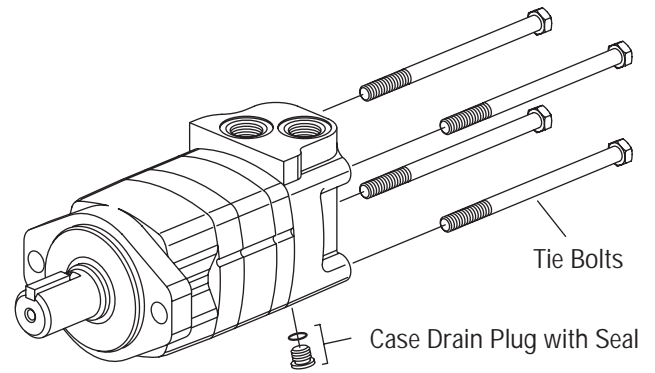

Figure 18

Wheel Motor

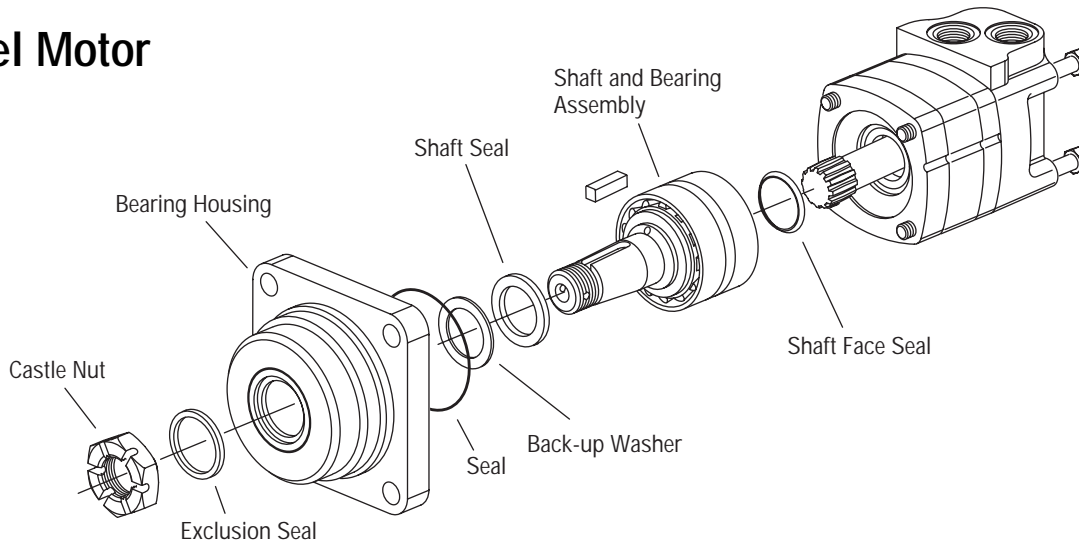

Figure 19

On wheel motors, a different bearing housing is used, see Figure 19. Other than this the parts are the same as the standard motor and the same disassembly and reassembly procedures apply.

Wheel Motor with Seal Guard

Installation of Seal Guard:

After completing assembly of the shaft and bearing assembly into the bearing housing, press the seal guard onto the shaft with a tool that will provide an even push over the seal. This tool must bottom out against the bearing housing and provide a 4,5 mm [.177 inch] stop for the seal guard.

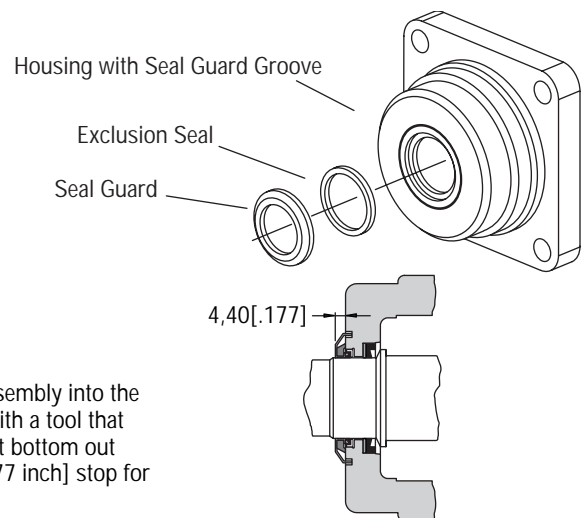

Bearingless Motor

This motor is the same as the standard motor without the shaft/bearing assembly, and bearing housing. The mounting flange replaces the bearing housing, see Figure 20. Follow same disassembly and reassembly procedures as rear section of standard motor.

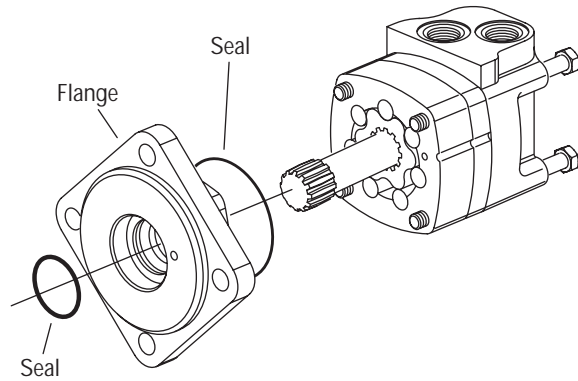

Figure 20

Disassembly Reassembly Shuttle Valve Option

Disassembly of shuttle valve option, this valve is located in the valve housing. Clean and inspect shuttle valve parts and reassemble with new seals, torque plugs to 8-11 Nm [75-100 lb-in].

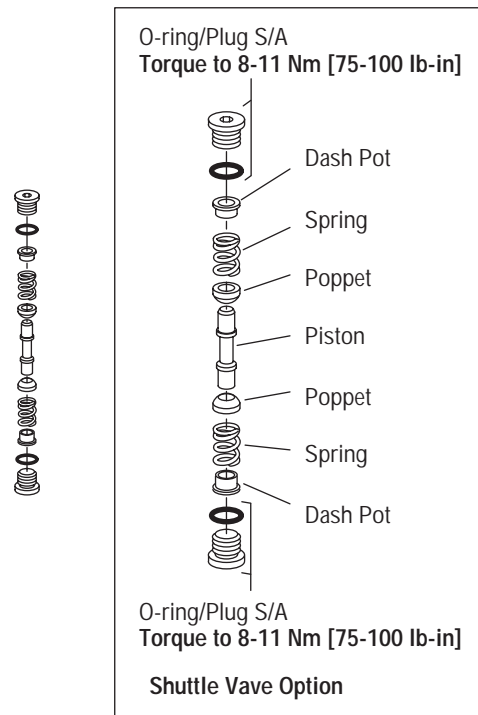
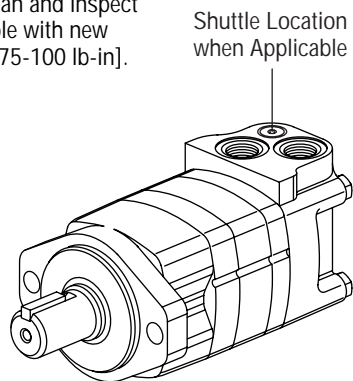

Figure 21

Reassembly — Speed Sensor

1 Rotate the motor shaft until a (gear/target) tooth is centered in the speed sensor port. If this is not done, the sensor may be damaged during the operation of the motor.

2 Make sure the lock nut and its threads are clean and dry for the proper torque. Position the lock nut against the alignment nut as shown in Figure 22.

3 Move the washer and the o-ring up against the speed sensor body threads as shown in Figure 22.

4 By hand, lightly thread the speed sensor body into the housing until the sensor touches against the motor (gear/target) tooth. **Do not force the sensor against the (gear/target) tooth, damage may occur.** Make sure the o-ring or the washer do not touch the housing — see Figure 23.

5 Turn the speed sensor body out one quarter turn (CCW) plus the additional amount (CCW) needed to make the alignment notches perpendicular to the motor shaft centerline ($90^\circ \pm 5$ degrees from the motor shaft centerline — Figure 24 and 25).

6 Maintain the speed sensor body alignment (Figure 25), and tighten the lock nut to 8,5-14 Nm [75-125 lb-in.] (torque values are for clean dry threads).

7 Check the speed sensor body for correct alignment (Figure 25), reinstall the sensor if it is not correct.

Speed Sensor Installation

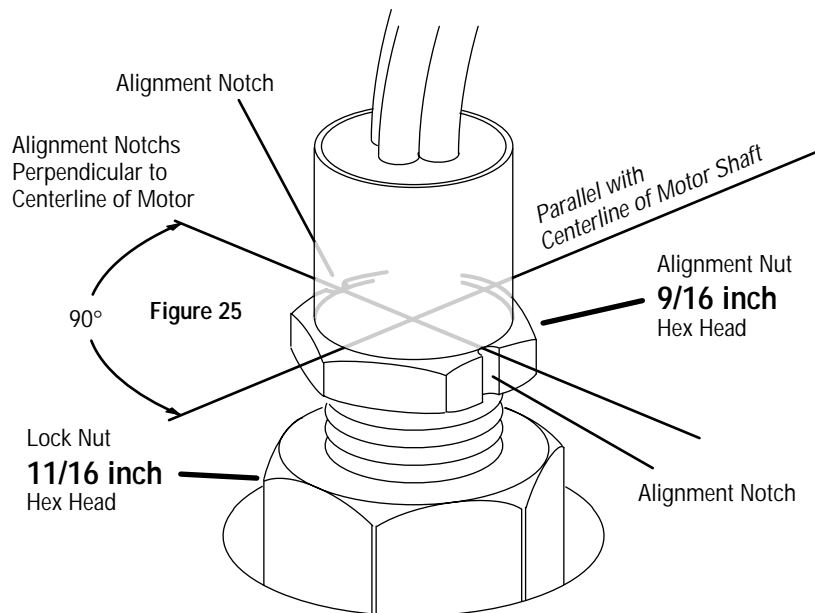
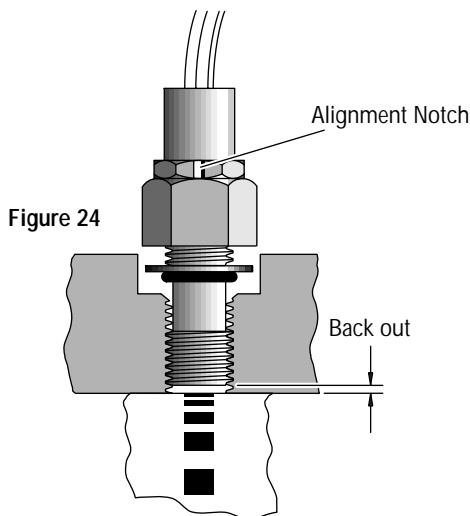
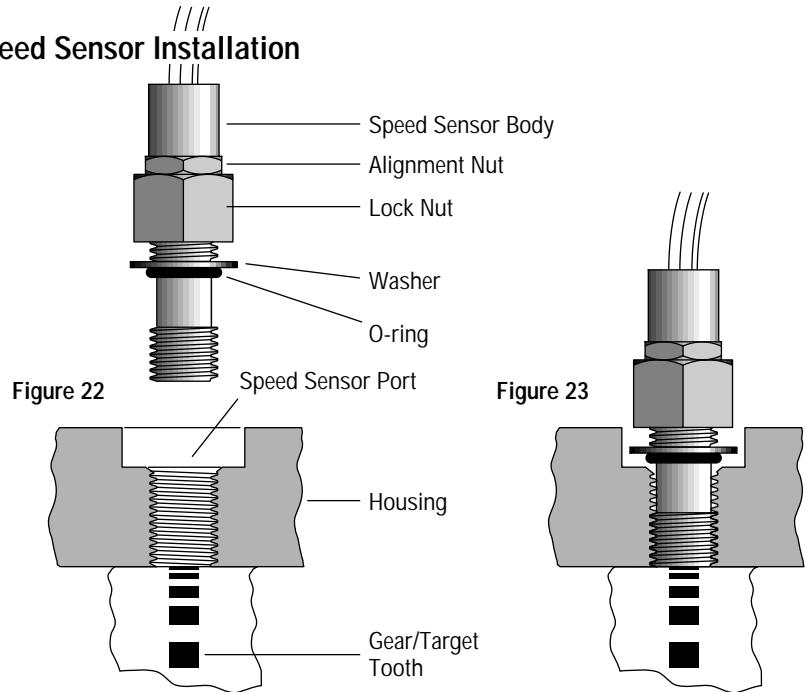

Product Identification

For Additional Literature Contact Eaton Corp. Hydraulics Division 15151 Highway 5 Eden Prairie, MN 55344.

- Specifications and performance data, Catalog No. 11-878
- Replacement part numbers and kit information — Parts Information No. 6-129

How to Order Replacement Parts

Each Order Must Include the Following:

1. Product Number
2. Date Code
3. Part Name
4. Part Number
5. Quantity of Parts

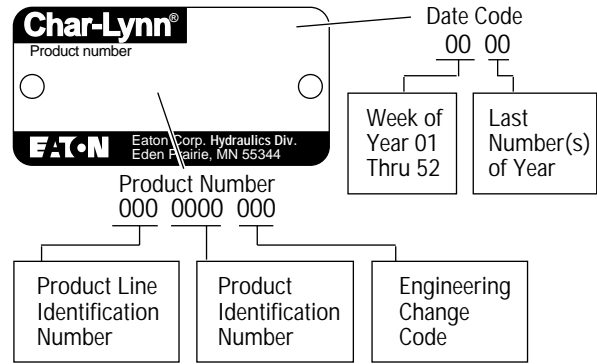

Product Numbers—2000 Series

Use digit prefix —104-, 105-, or 106- plus four digit number from charts for complete product number—Example 106-1039.

104-1007

Mounting	Shaft	Ports	Displacement cm ³ /r [in ³ /r] and Product Number								
			80 [4.9]	100 [6.2]	130 [8.0]	160 [9.6]	195 [11.9]	245 [14.9]	305 [18.7]	395 [24.0]	490 [29.8]
2 Bolt SAE A Flange	1 inch Straight	7/8-14 O-ring Staggered	104-1001	-1002	-1003	-1004	-1005	-1006	-1007	-1143	—
		1-1/16—12 O-ring 180° Apart	104-1037	-1038	-1039	-1040	-1041	-1042	-1043	-1044	—
	1-1/4 Inch Straight	7/8-14 O-ring Staggered	104-1022	-1023	-1024	-1025	-1026	-1027	-1028	-1228	-1420
		1-1/16—12 O-ring 180° Apart	104-1061	-1062	-1063	-1064	-1065	-1066	-1067	-1068	-1421
1-1/4 Inch 14 T Splined	7/8-14 O-ring Staggered	104-1029	-1030	-1031	-1032	-1033	-1034	-1035	-1229	-1422	
	1-1/16—12 O-ring 180° Apart	104-1087	-1088	-1089	-1090	-1091	-1092	-1093	-1094	-1423	
2 Bolt SAE B Flange	1-1/4 Inch Straight	7/8-14 O-ring Staggered	104-1200	-1201	-1202	-1203	-1204	-1205	-1206	-1207	—
	1-1/4 In. Involute SAE C Splined	7/8-14 O-ring Staggered	104-1208	-1209	-1210	-1211	-1212	-1213	-1214	-1215	—
	1 Inch SAE 6B Splined	7/8-14 O-ring Staggered	104-1193	-1194	-1195	-1196	-1197	-1198	-1199	—	—
	7/8 Inch SAE B Splined	7/8-14 O-ring Staggered	104-1216	-1217	-1218	-1219	-1220	—	—	—	—
Standard with 4 Bolt Square Flange	32 mm Straight	G 1/2 (BSP)	104-1384	-1385	-1386	-1387	-1388	-1389	-1390	-1391	—
	1-1/4 Inch 14 T Splined	G 1/2 (BSP)	104-1376	-1377	-1378	-1379	-1380	-1381	-1382	-1383	—
Wheel Motor	1-1/4 Inch Straight	7/8-14 O-ring Staggered	105- —	—	—	—	—	—	—	—	-1148
		1-1/16—12 O-ring 180° Apart	105- —	—	—	—	—	—	—	—	-1149
	32 mm Straight	G 1/2 (BSP)	105-1134	-1135	-1136	-1137	-1138	-1139	-1140	-1141	—
		7/8-14 O-ring Staggered	105-1001	-1002	-1003	-1004	-1005	-1006	-1007	-1060	-1152
	1-1/4 Inch Tapered	1-1/16—12 O-ring 180° Apart	105-1071	-1072	-1073	-1074	-1075	-1076	-1077	-1078	—
		7/8-14 O-ring Staggered	105-1029	-1030	-1031	-1032	-1033	-1034	-1035	-1096	—
1-1/4 Inch 14 T Splined	1-1/16—12 O-ring 180° Apart	105-1079	-1080	-1081	-1082	-1083	-1084	-1085	-1086	—	
	7/8-14 O-ring Staggered	106-1008	-1009	-1010	-1011	-1012	-1013	-1014	-1015	-1047	
Bearingless		G 1/2 (BSP)	106-1038	-1039	-1040	-1041	-1042	-1043	-1044	-1045	—

Eaton Corporation
Hydraulics Division
15151 Hwy. 5
Eden Prairie, MN 55344
Telephone: 612/937-7254
Fax: 612/937-7130

Sumitomo Eaton
Hydraulic Company Ltd.
Ooi-Cho Kameoka-Shi
621-0017 Kyoto
Japan
Telephone: [+81] 771-22-9601
Fax: [+81] 771-29-2020

Eaton Ltd.
Hydraulics Division
Glenrothes, Fife
Scotland, KY7 4NW
Telephone: [+44] (0)1592-771-771
Fax: [+44] (0)1592-773-184

Eaton Ltd.
7th Floor, Woo Duk Building
832-2 Yeoksam-Dong, Kangnam-Ku
Soeul 135-750
Korea
Telephone: [+82] 2-557-0595
Fax: [+82] 2-557-1634

Eaton B.V.
Boeing Avenue 11
1119 PC Schiphol-Rijk
The Netherlands
Telephone: [+31] (0)20-655 6776
Fax: [+31] (0)20-655 6800

Eaton Hydraulics (Shanghai) Co. Ltd.
388 Aidu Road, Waigaogiao FTZ
Pudong New Area
Shanghai 200137
Peoples Republic of China
Telephone: [+86] 21-5046 0758
Fax: [+86] 21-5046 0767

Sumitomo Eaton Hydraulic Co.
8 Temasek Blvd.
42-01 Suntec Tower Three
Singapore 03988
Telephone: [+65] 832-7727
Fax: [+65] 832-7733

Jining Eaton Hydraulic Co. Ltd.
6 Ji Da Road
Jining City
Shandong Province 272131
Peoples Republic of China
Telephone: [+86] 537-2221288
Fax: [+86] 537-2221557



Quality System Certified
Products in this catalog are manufactured
in an ISO-9001-certified site.