



WHEEL HORSE[®]

Lawn And Garden Tractor

36" TILLER

Model No. 79271- 5900001 & Up

Parts Catalog

ORDERING REPLACEMENT PARTS

To order replacement parts, please supply: the part number, the quantity, and the description of each part desired.

Part Description Abbreviations

Part descriptions in this catalog may include the following abbreviations.

Abbreviation	Meaning	Abbreviation	Meaning
AR	as required	HWHTF	hex washer head thread forming
ASM	assembly	INCL	includes
CARR	carriage	LH	left hand
DEG	degrees	PH	pan head
FH	flat head	PPH	Phillips pan head
GA	gauge	PTO	power take off
HF	hex flange	RH	right hand
HFV	hex flange washer	SFH	slotted fillister head
HH	hex head	SH	square head
HHF	hex head flange	SHWH	slotted hex washer head
HHST	hex head self tapping	SPH	slotted pan head
HJ	hex jam	STD	standard
HOC	height-of-cut	TAP	self tapping
HS	hex socket	TH	truss head
HSBH	hex socket button head	TTH	Torx truss head
HSFH	hex socket flat head	WH	wing head
HSH	hex socket head		
HWH	hex washer head		

Important Format Explanations

This catalog uses special formats to convey information in illustrations and parts lists. Specifically, one format is used in conjunction with service assemblies and another with quantities associated with reference numbers.

Service Assemblies

Parts within service assemblies have reference numbers in the form *X:Y*. *X* is the reference number of the service assembly and *Y* is a sequential number unique to each part within the service assembly.

For example, a wheel assembly might be identified by reference number 6, the tire by 6:1, the valve by 6:2, and the wheel by 6:3. When you order the assembly identified by reference number 6, you receive all parts identified by reference numbers 6:1, 6:2, and 6:3. However, you may also order any part individually.

Reference numbers of this type appear in part lists and as callouts in illustrations.

Reference Numbers with Quantities

Illustrations may have a quantity in parentheses next to a reference number, in the form *X (Y)*. *X* is the reference number. *Y* in parentheses is the quantity of the part identified by the reference number.

For example, the illustration callout 4 (2) indicates that two parts are used in that instance.

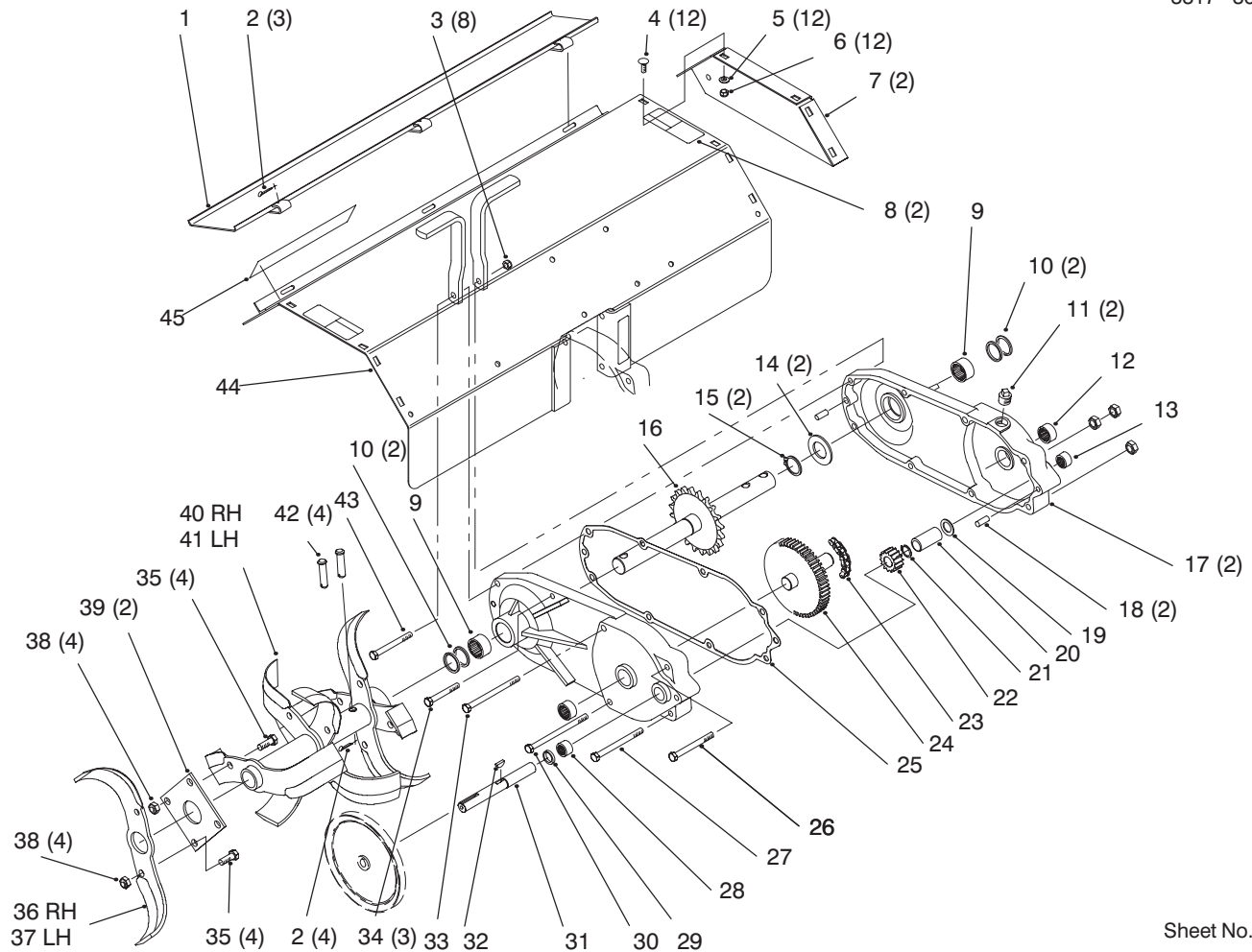

Sheet No.: 2

Guard, Shield, Gear Case & Tines

Ref. No.	Part No.	Description	No. Used
1	93-1609-01	Panel	1
2	3272-11	Pin-Cotter	7
3	3296-39	Nut-Lock	8
4	3230-1	Screw-CARR	12
5	3256-23	Washer-Flat	12
6	3296-29	Nut-Lock	12
7	93-1605-01	Cover-End	2
8	92-7112	Decal-Danger	2
9	6838	Bearing-Needle	2
10	103118	Seal-Oil	4
11	281-3	Plug-Pipe	2
12	1532	Bearing-Needle	2
13	1529	Bearing-Needle	1
14	106011	Washer-Flat	2
15	32120-33	Ring-Retaining	2
16	106009	Shaft And Sprocket ASM	1
17	93-1600-01	Gearcase-Half	2
18	32121-41	Pin-Roll	2
19	1535	Washer-Thrust	1
20	83-3340	Tube-Spacer	1
21	32120-72	Ring-Retaining	1
22	3528	Gear-Pinion	1
23	6848	Chain-Sprocket	1

Ref. No.	Part No.	Description	No. Used
24	106007	Shaft And Sprocket ASM	1
25	83-3330	Gasket-Transmission	1
26	323-42	Screw-HH	1
27	323-23	Screw-HH	1
28	1540	Bearing-Needle	1
29	100441	Seal-Oil	1
30	323-25	Screw-HH	1
31	104387	Shaft-Input	1
32	3257-5	Key-Woodruff	1
33	323-21	Screw-HH	1
34	323-13	Screw-HH	3
35	324-4	Screw-HH	8
36	92-1653-03	Tine-RH	1
37	93-1604-03	Tine-LH	1
38	3296-48	Nut-Lock	8
39	93-1601-03	Plate-Mounting	2
40	93-1602-03	Tine-RH	1
41	93-1603-03	Tine-LH	1
42	9208	Pin-Clevis	4
43	323-15	Screw-HH	1
44	92-6514-01	Shield W/ Safety Decal	1
45	92-8748	Decal-Attachment	1

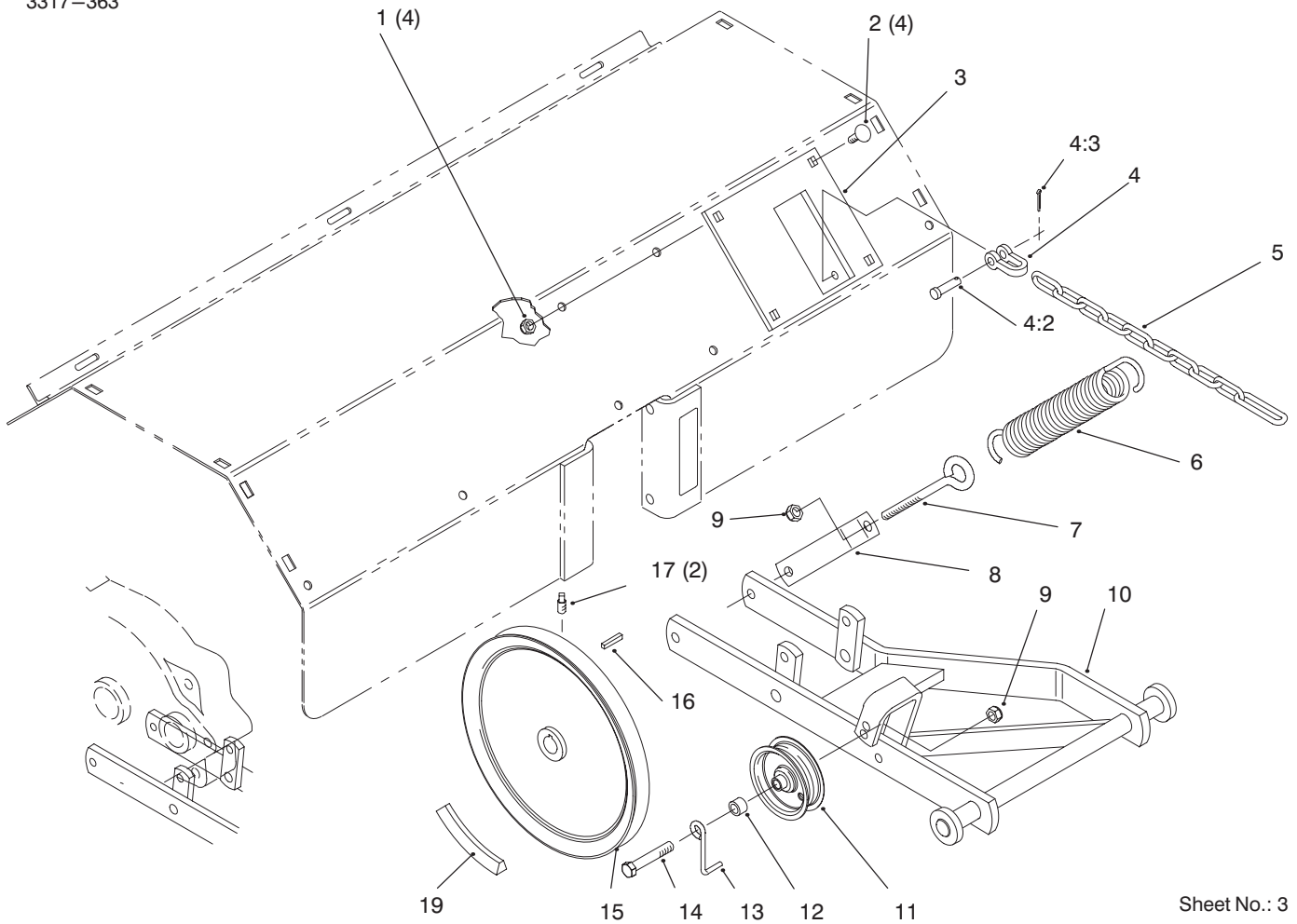

Sheet No.: 3

Hitch, Drive & Idler Pulleys

Ref. No.	Part No.	Description	No. Used
1	3296-29	Nut-Lock	4
2	3230-1	Screw-CARR	4
3	93-1608-01	Plate	1
4	79-2280	Clevis Pins Assembly	1
4:2	105821	Pin - Clevis	1
4:3	3272-6	Pin - Cotter	1
5	92-7074	Chain-Lift	1
6	4629	Spring-Extension	1
7	100653	Eyebolt	1
8	93-1606-01	Bracket-Spring	1

Ref. No.	Part No.	Description	No. Used
9	3296-39	Nut-Lock	2
10	93-1607-01	Hitch	1
11	92-7104	Pulley-Idler	1
12	93-3658	Spacer	1
13	79-0400	Guide-Belt	1
14	323-11	Screw	1
15	93-0345	Pulley	1
16	1005	Key-Square	1
17	3242-2	Screw Set-SH	2
19	93-1628	Decal-Belt Routing	1

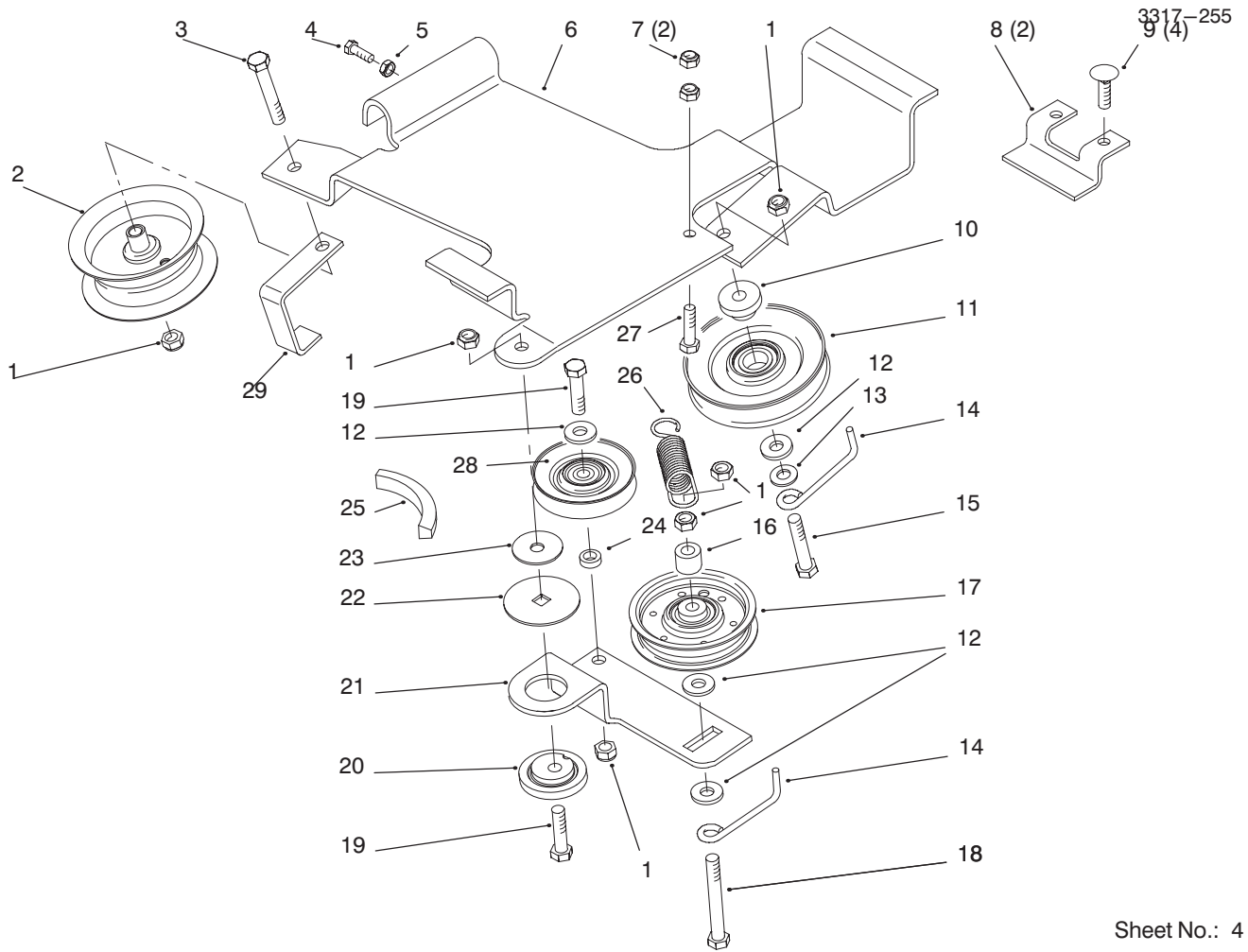

Sheet No.: 4

Mid Hitch Idler Asm

Ref. No.	Part No.	Description	No. Used
1	3296-39	Nut-Lock	6
2	49-6980	Pulley-Idler	1
3	323-11	Screw	1
4	3235-20	Screw	1
5	3218-1	Nut-Jam	1
6	92-7033-03	Rack-Tiller Drive	1
7	3296-29	Nut-Lock	2
8	93-1388-03	Bracket-Rack Mounting	2
9	3230-2	Screw-CARR	4
10	83-2950	Spacer	1
11	92-7103	Pulley-Idler	1
12	9202414	Washer-Flat	4
13	3256-24	Washer-Flat	1
14	79-0390	Guide-Belt	2
15	323-10	Screw-HH	1

Ref. No.	Part No.	Description	No. Used
16	108326-03	Spacer-Pivot	1
17	92-7101	Pulley-Flat	1
18	323-14	Screw	1
19	323-8	Screw-HH	2
20	111418	Bushing	1
21	78-6771	Arm-Idler	1
22	111419	Washer-Bearing	1
23	9202494	Wash-Fender	1
24	93-3658	Spacer	1
25	92-7075	Belt-V	1
26	92-7149	Spring-Ext	1
27	322-6	Screw-HH	1
28	92-7102	Pulley-Idler	1
29	92-7022-03	Guide-Belt	1

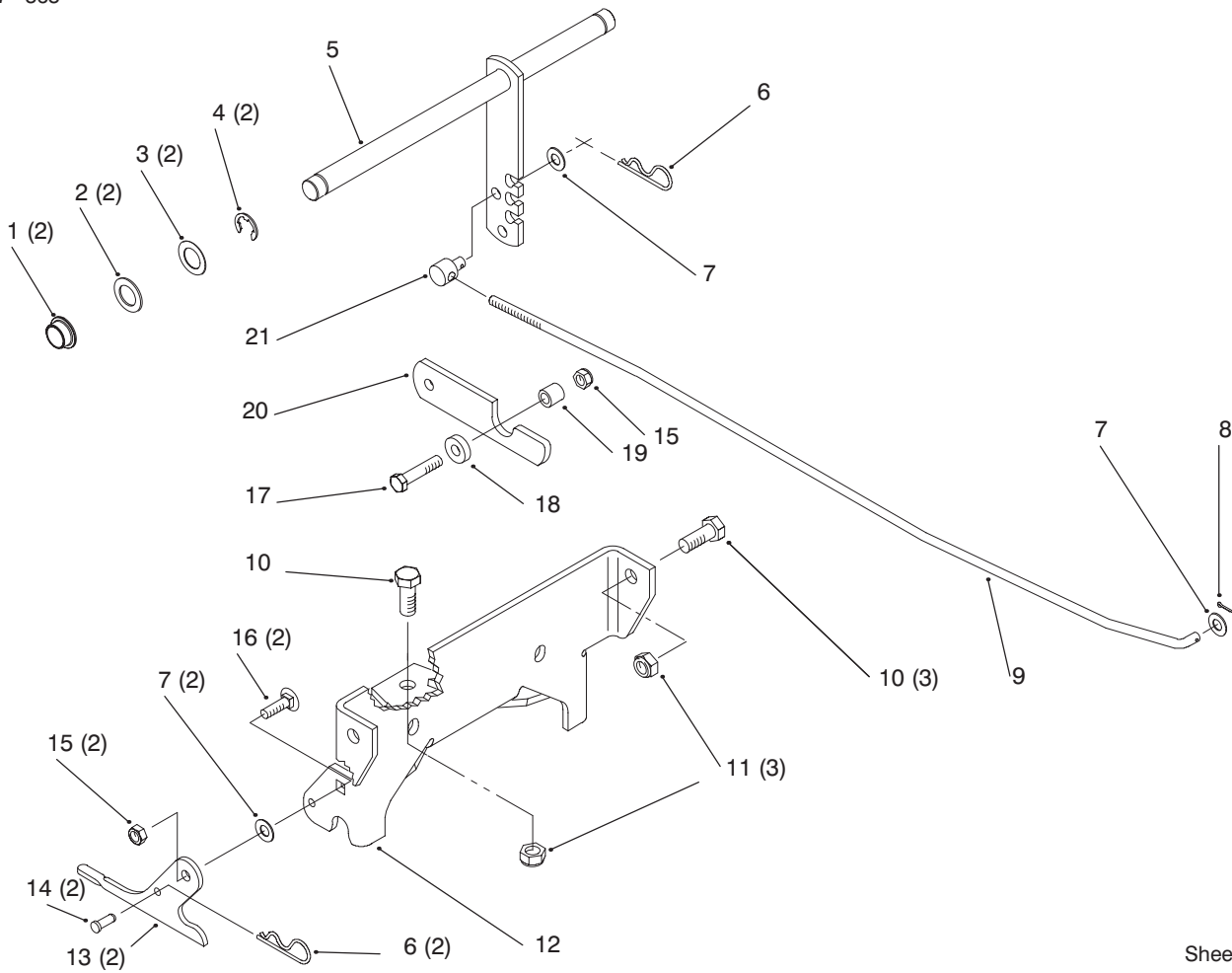

Sheet No.: 5

Rear Axle Mount Hitch

Ref. No.	Part No.	Description	No. Used
1	108519	Bushing	2
2	1278	Washer-Shim	2
3	5210	Washer-Shim	2
4	5618	Ring-Retaining	2
5	92-7064-03	Lever	1
6	9335044	Hairpin	3
7	3256-24	Washer-Flat	4
8	3272-6	Pin-Cotter	1
9	92-7069	Rod-Lift	1
10	325-5	Screw-HH	3
11	3296-23	Nut-Lock	3

Ref. No.	Part No.	Description	No. Used
12	93-1389-03	Bracket-Mtg	1
13	104657	Handle-Latch	2
14	9321204	Pin-Clevis	2
15	3296-39	Nut-Lock	3
16	3231-2	Screw-CARR	2
17	323-9	Screw-HH	1
18	9202204	Washer	1
19	105474	Spacer	1
20	92-7023-03	Catch-Spring	1
21	104524	Trunnion	1

TORO PART NUMBER INDEX

3317-363

Part No.	Description	Pg. No.	Ref. No.	Qty.	Part No.	Description	Pg. No.	Ref. No.	Qty.
1005	Key-Square	2	16	1	93-1388-03	Bracket-Rack Mounting	3	8	2
1278	Washer-Shim	4	2	2	93-1389-03	Bracket-Mtg	4	12	1
1529	Bearing-Needle	1	13	1	93-1600-01	Gearcase-Half	1	17	2
1532	Bearing-Needle	1	12	2	93-1601-03	Plate-Mounting	1	39	2
1535	Washer-Thrust	1	19	1	93-1602-03	Tine-RH	1	40	1
1540	Bearing-Needle	1	28	1	93-1603-03	Tine-LH	1	41	1
3528	Gear-Pinion	1	22	1	93-1604-01	Tine-LH	1	37	1
4629	Spring-Extension	2	6	1	93-1605-01	Cover-End	1	7	2
5210	Washer-Shim	4	3	2	93-1606-01	Bracket-Spring	2	8	1
5618	Ring-Retaining	4	4	2	93-1607-01	Hitch	2	10	1
6838	Bearing-Needle	1	9	2	93-1608-01	Plate	2	3	1
6848	Chain-Sprocket	1	23	1	93-1609-01	Panel	1	1	1
9208	Pin-Clevis	1	42	4	93-1628	Decal-Belt Routing	2	19	1
100441	Seal-Oil	1	29	1	93-3658	Spacer	2	12	1
100653	Eyebolt	2	7	1	93-3658	Spacer	3	24	1
103118	Seal-Oil	1	10	4	108326	Spacer-Pivot	3	16	1
104387	Shaft-Input	1	31	1	281-3	Plug-Pipe	1	11	2
104524	Trunnion	4	21	1	322-6	Screw-HH	3	27	1
104657	Handle-Latch	4	13	2	323-8	Screw-HH	3	19	2
105474	Spacer	4	19	1	323-9	Screw-HH	4	17	1
106007	Shaft And Sprocket ASM	1	24	1	323-10	Screw-HH	3	15	1
106009	Shaft And Sprocket ASM	1	16	1	323-11	Screw	3	3	1
106011	Washer-Flat	1	14	2	323-11	Screw	2	14	1
111418	Bushing	3	20	1	323-13	Screw-HH	1	34	3
111419	Washer-Bearing	3	22	1	323-14	Screw	3	18	1
9202204	Washer	4	18	1	323-15	Screw-HH	1	43	1
9202414	Washer-Flat	3	12	4	323-21	Screw-HH	1	33	1
9202494	Wash-Fender	3	23	1	323-23	Screw-HH	1	27	1
9321204	Pin-Clevis	4	14	2	323-25	Screw-HH	1	30	1
9335044	Hairpin	4	6	3	323-42	Screw-HH	1	26	1
108519	Bushing	4	1	2	324-4	Screw-HH	1	35	8
49-6980	Pulley-Idler	3	2	1	325-5	Screw-HH	4	10	3
78-6771	Arm-Idler	3	21	1	3218-1	Nut-Jam	3	5	1
79-0390	Guide-Belt	3	14	2	3230-1	Screw-CARR	2	2	4
79-0300	Guide-Belt	2	13	1	3230-1	Screw-CARR	1	4	12
79-2280	Clevis W/ Pins	2	4	1	3230-2	Screw-CARR	3	9	4
83-2950	Spacer	3	10	1	3231-2	Screw-CARR	4	16	2
83-3330	Gasket-Transmission	1	25	1	3235-20	Screw	3	4	1
83-3340	Tube-Spacer	1	20	1	3242-2	Screw Set-SH	2	17	2
92-1653-03	Tine-RH	1	36	1	3256-23	Washer-Flat	1	5	12
92-6514-01	Shield W/ Safety Decal	1	44	1	3256-24	Washer-Flat	4	7	4
92-7022-03	Guide-Belt	3	29	1	3256-24	Washer-Flat	3	13	1
92-7023-03	Catch-Spring	4	20	1	3257-5	Key-Woodruff	1	32	1
92-7033-03	Rack-Tiller Drive	3	6	1	3272-6	Pin-Cotter	4	8	1
92-7064-03	Lever	4	5	1	3272-11	Pin-Cotter	1	2	7
92-7069	Rod-Lift	4	9	1	3296-23	Nut-Lock	4	11	3
92-7074	Chain-Lift	2	5	1	3296-29	Nut-Lock	1	6	12
92-7075	Belt-V	3	25	1	3296-29	Nut-Lock	3	7	2
92-7101	Pulley-Flat	3	17	1	3296-39	Nut-Lock	1	3	8
92-7102	Pulley-Idler	3	28	1	3296-39	Nut-Lock	2	9	2
92-7103	Pulley-Idler	3	11	1	3296-39	Nut-Lock	4	15	3
92-7104	Pulley-Idler	2	11	1	3296-48	Nut-Lock	1	38	8
92-7112	Decal-Danger	1	8	2	32120-33	Ring-Retaining	1	15	2
92-7149	Spring-Ext	3	26	1	32120-72	Ring-Retaining	1	21	1
92-8748	Decal-Attachment	1	45	1	32121-41	Pin-Roll	1	18	2
93-0345	Pulley	2	15	1					

*Not Illustrated

