



Count on it.

Operator's Manual

Wheel Horse XL 440H Lawn Tractor

Model No. 71253—Serial No. 31000001 and Up

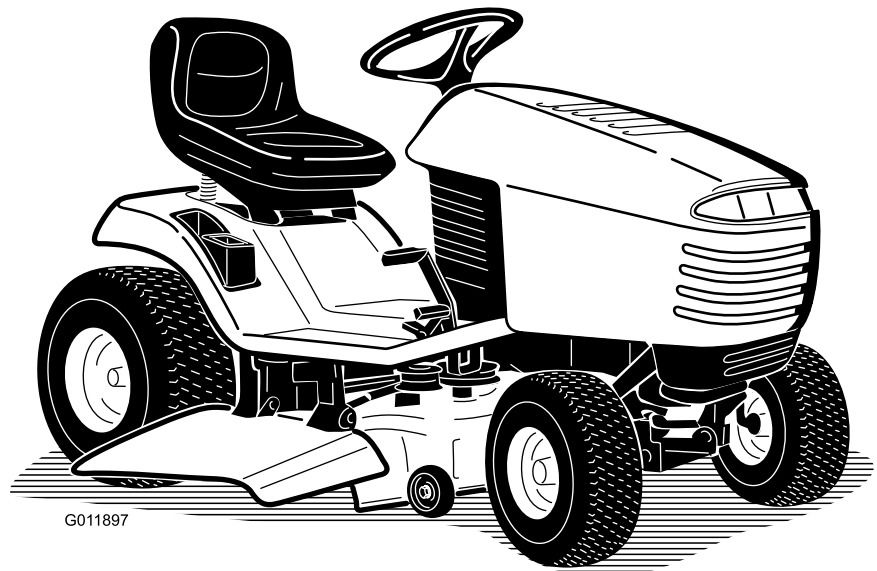

G011897



This product complies with all relevant European directives. For details, see the separate product specific Declaration of Conformity (DOC) sheet.



Figure 2

Introduction

This rotary-blade, riding lawn mower is intended to be used by residential homeowners. It is designed primarily for cutting grass on well-maintained lawns on residential properties. It is not designed for cutting brush or for agricultural uses.

Read this information carefully to learn how to operate and maintain your product properly and to avoid injury and product damage. You are responsible for operating the product properly and safely.

You may contact Toro directly at www.Toro.com for product and accessory information, help finding a dealer, or to register your product.

Whenever you need service, genuine Toro parts, or additional information, contact an Authorized Service Dealer or Toro Customer Service and have the model and serial numbers of your product ready. Figure 1 identifies the location of the model and serial numbers on the product. Write the numbers in the space provided.

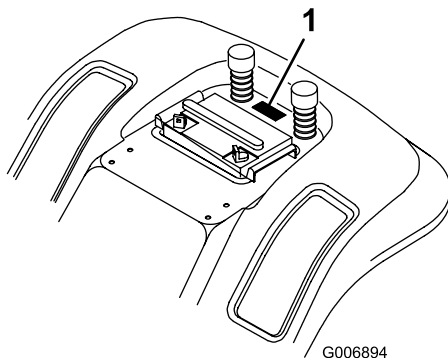

Figure 1

1. Model and serial number location

| |
|-------------------------|
| Model No. _____ |
| Serial No. _____ |

This manual identifies potential hazards and has safety messages identified by the safety alert symbol (Figure 2), which signals a hazard that may cause serious injury or death if you do not follow the recommended precautions.

1. Safety alert symbol

This manual uses 2 words to highlight information. **Important** calls attention to special mechanical information and **Note** emphasizes general information worthy of special attention.

Contents

| | |
|---|----|
| Introduction..... | 2 |
| Safety | 3 |
| Safe Operation Practices for Ride-on (Riding) | |
| Rotary Lawn Mowers..... | 3 |
| Toro Riding Mower Safety | 5 |
| Sound Pressure..... | 5 |
| Sound Power | 5 |
| Vibration..... | 5 |
| Slope Indicator..... | 6 |
| Safety and Instructional Decals | 7 |
| Product Overview | 9 |
| Controls | 9 |
| Specifications | 9 |
| Operation..... | 10 |
| Gasoline and Oil | 10 |
| Using the Parking Brake..... | 11 |
| Positioning the Seat | 11 |
| Operating the Headlights..... | 11 |
| Operating the Blade Control (PTO) | 12 |
| Setting the Height-of-Cut | 12 |
| Starting the Engine..... | 12 |
| Stopping the Engine | 13 |
| Using the Safety Interlock System | 13 |
| Testing the Safety Interlock System | 14 |
| Pushing the Tractor Manually | 14 |
| Driving Forward or Backward..... | 15 |
| Stopping the Tractor..... | 15 |
| Operating Tips | 15 |
| Maintenance..... | 17 |
| Recommended Maintenance Schedule(s) | 17 |
| Lubrication..... | 18 |
| Greasing and Lubricating the Tractor | 18 |
| Engine Maintenance..... | 18 |
| Servicing the Engine Oil..... | 18 |
| Servicing the Air Cleaner | 19 |
| Servicing the Spark Plug | 20 |
| Fuel System Maintenance | 21 |
| Draining the Fuel Tank | 21 |
| Replacing the Fuel Filter | 22 |

| | |
|---|----|
| Electrical System Maintenance..... | 22 |
| Servicing the Battery..... | 22 |
| Servicing the Fuse | 24 |
| Drive System Maintenance | 25 |
| Servicing the Transaxle Fluid | 25 |
| Cooling System Maintenance..... | 25 |
| Cleaning the Cooling System..... | 25 |
| Brake Maintenance | 26 |
| Servicing the Parking Brake | 26 |
| | 27 |
| Checking the Tire Pressure | 27 |
| Servicing the Headlights | 27 |
| Cleaning..... | 28 |
| Washing the Underside of the Mower..... | 28 |
| Storage..... | 29 |
| Troubleshooting..... | 30 |
| Schematics | 32 |

Safety

Safe Operation Practices for Ride-on (Riding) Rotary Lawn Mowers

Read and understand the contents of this manual before operating the tractor.

The following instructions are from the CEN standard EN 836:1997.

This product is capable of amputating hands and feet and of throwing objects. Always follow all safety instructions to avoid serious injury or death.

Training

- Read the instructions carefully. Be familiar with the controls and the proper use of the equipment.
- Never allow children or people unfamiliar with these instructions to use the lawnmower. Local regulations can restrict the age of the operator.
- Never mow while people, especially children, or pets are nearby.
- Keep in mind that the operator or user is responsible for accidents or hazards occurring to other people or their property.
- Do not carry passengers.
- All drivers should seek and obtain professional and practical instruction. Such instruction should emphasize:
 - the need for care and concentration when working with ride-on machines;
 - control of a ride-on machine sliding on a slope will not be regained by the application of the brake. The main reasons for loss of control are:
 - ◇ insufficient wheel grip;
 - ◇ being driven too fast;
 - ◇ inadequate braking;
 - ◇ the type of machine is unsuitable for its task;
 - ◇ lack of awareness of the effect of ground conditions, especially slopes;
 - ◇ incorrect hitching and load distribution.

Preparation

- While mowing, always wear substantial footwear and long trousers. Do not operate the equipment when barefoot or wearing open sandals.

- Thoroughly inspect the area where the equipment is to be used and remove all objects which may be thrown by the machine.
- **Warning**—Fuel is highly flammable.
 - Store fuel in containers specifically designed for this purpose.
 - Refuel outdoors only and do not smoke while refuelling.
 - Add fuel before starting the engine. Never remove the cap of the fuel tank or add fuel while the engine is running or when the engine is hot.
 - If fuel is spilled, do not attempt to start the engine but move the machine away from the area of spillage and avoid creating any source of ignition until fuel vapors have dissipated.
 - Replace all fuel tanks and container caps securely.
- Replace faulty silencers.
- Before using, always visually inspect to see that the blades, blade bolts and cutter assembly are not worn or damaged. Replace worn or damaged blades and bolts in sets to preserve balance.
- On multi-bladed machines, take care as rotating one blade can cause other blades to rotate.
- Use care when pulling loads or using heavy equipment.
 - Use only approved drawbar hitch points.
 - Limit loads to those you can safely control.
 - Do not turn sharply. Use care when reversing.
 - Use counterweight(s) or wheel weights when suggested in the instruction handbook.
- Lightning can cause severe injury or death. If you see lightning or hear thunder in the area, do not operate the machine; seek shelter.
- Watch out for traffic when crossing or near roadways.
- Stop the blades rotating before crossing surfaces other than grass.
- When using any attachments, never direct discharge of material toward bystanders nor allow anyone near the machine while in operation.
- Never operate the machine with damaged guards or without safety protective devices in place.
- Do not change the engine governor settings or overspeed the engine. Operating the engine at excessive speed can increase the hazard of personal injury.
- Before leaving the operator's position:
 - disengage the power take-off and lower the attachments;
 - change into neutral and set the parking brake;
 - stop the engine and remove the key.

Operation

- Do not operate the engine in a confined space where dangerous carbon monoxide fumes can collect.
- Mow only in daylight or in good artificial light.
- Before attempting to start the engine, disengage all blade attachment clutches and shift into neutral.
- Do not use on slopes of more than
 - 10° when mowing on side hills;
 - 15° when mowing uphill;
 - 15° when mowing downhill.
- Remember there is no such thing as a safe slope. Travel on grass slopes requires particular care. To guard against overturning:
 - do not stop or start suddenly when going up or downhill;
 - engage clutch slowly, always keep machine in gear, especially when travelling downhill;
 - machine speeds should be kept low on slopes and during tight turns;
 - stay alert for humps and hollows and other hidden hazards;
 - never mow across the face of the slope, unless the lawn mower is designed for this purpose.
- Disengage drive to attachments, stop the engine, and disconnect the spark plug wire(s) or remove the ignition key
 - before clearing blockages or unclogging chute;
 - before checking, cleaning or working on the lawn mower;
 - after striking a foreign object. Inspect the lawn mower for damage and make repairs before restarting and operating the equipment;
 - if the machine starts to vibrate abnormally (check immediately).
- Disengage drive to attachments when transporting or not in use.
- Stop the engine and disengage drive to attachment
 - before refuelling;
 - before removing the grass catcher;

- before making height adjustment unless adjustment can be made from the operator's position.
- Reduce the throttle setting during engine run-out and, if the engine is provided with a shut-off valve, turn the fuel off at the conclusion of mowing.

Maintenance and Storage

- Keep all nuts, bolts and screws tight to be sure the equipment is in safe working condition.
- Never store the equipment with fuel in the tank inside a building where fumes can reach an open flame or spark.
- Allow the engine to cool before storing in any enclosure.
- To reduce the fire hazard, keep the engine, silencer, battery compartment and fuel storage area free of grass, leaves, or excessive grease.
- Check the grass catcher frequently for wear or deterioration.
- Replace worn or damaged parts for safety.
- If the fuel tank has to be drained, this should be done outdoors.
- On multi-bladed machines, take care as rotating one blade can cause other blades to rotate.
- When machine is to be parked, stored or left unattended, lower the cutting means unless a positive mechanical lock is used.

Toro Riding Mower Safety

The following paragraph contains safety information specific to Toro products that is not included in the CEN standard.

Use only Toro-approved attachments. The warranty may be voided if you use the tractor with unapproved attachments.

Sound Pressure

This unit has a sound pressure level at the operator's ear of 91 dBA, which includes an Uncertainty Value (K) of 1 dBA. The sound pressure level was determined according to the procedures outlined in EN 836.

Sound Power

This unit has a guaranteed sound power level of 100 dBA, which includes an Uncertainty Value (K) of 1 dBA. The sound power level was determined according to the procedures outlined in ISO 11094.

Vibration

This unit does not exceed hand/arm vibration levels of 4.7 m/s^2 for the left hand and 6.7 m/s^2 for the right hand, each including an Uncertainty Value (K) of 2.7 m/s^2 . The measured values were determined according to the procedures outlined in EN 836.

This unit does not exceed hand/arm vibration levels of 0.94 m/s^2 for the whole body, including an Uncertainty Value (K) of 0.47 m/s^2 . The measured value was determined according to the procedures outlined in EN 836.

Slope Indicator

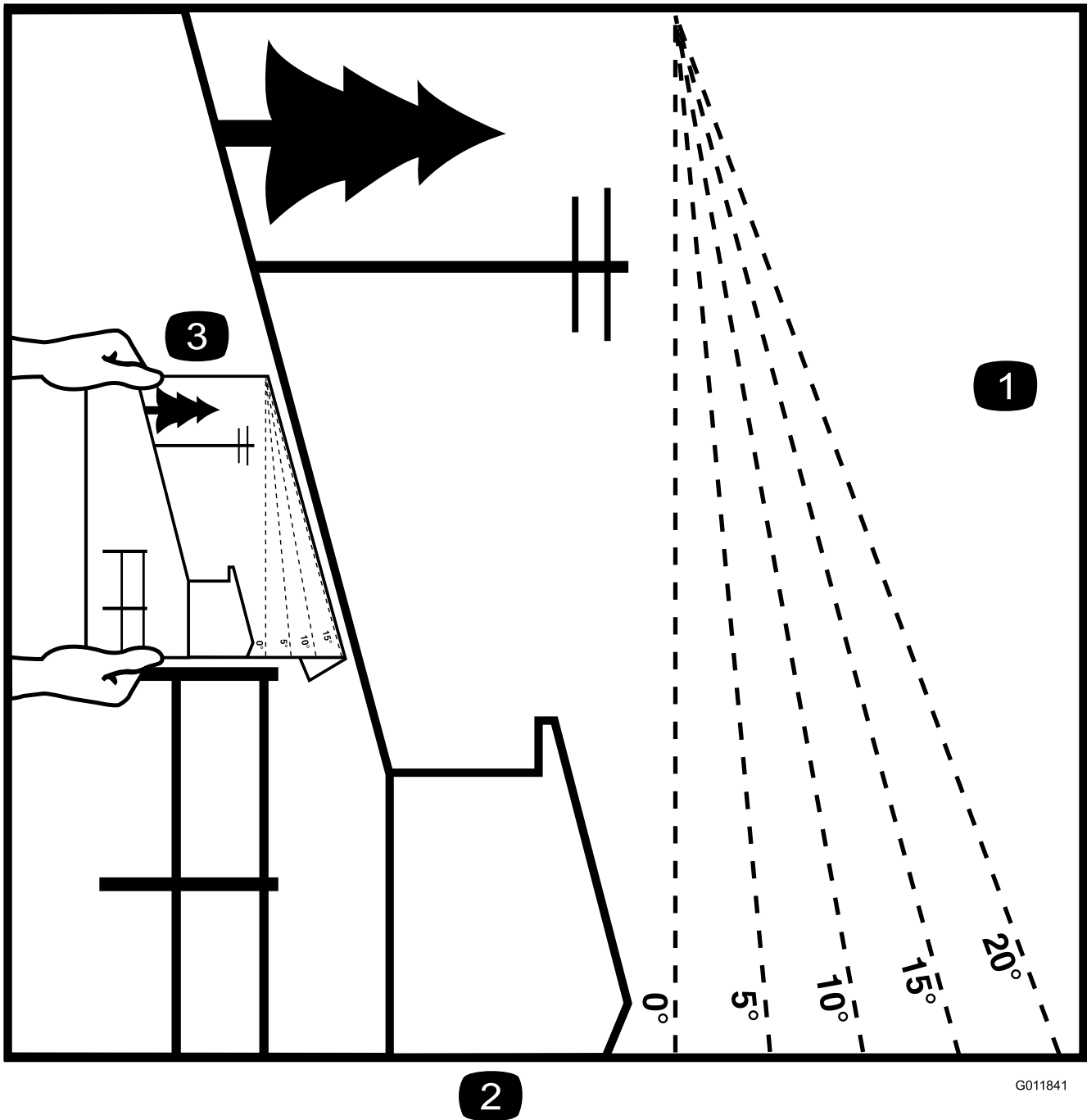

2

G011841

Figure 3

This page may be copied for personal use.

1. The maximum slope you can safely operate the machine on is **15 degrees**. Use the slope chart to determine the degree of slope of hills before operating. **Do not operate this machine on a slope greater than 15 degrees**. Fold along the appropriate line to match the recommended slope.
2. Align this edge with a vertical surface, a tree, building, fence pole, etc.
3. Example of how to compare slope with folded edge.

Safety and Instructional Decals



Safety decals and instructions are easily visible to the operator and are located near any area of potential danger. Replace any decal that is damaged or lost.

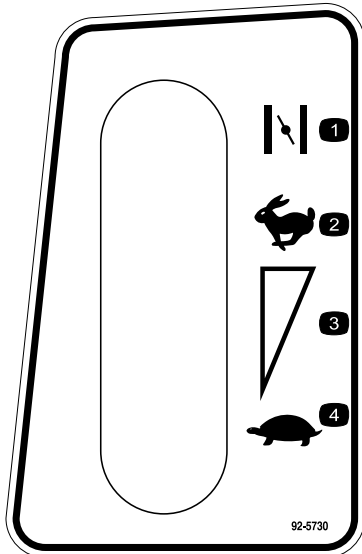

92-5730

- | | |
|----------|--------------------------------|
| 1. Choke | 3. Continuous variable setting |
| 2. Fast | 4. Slow |

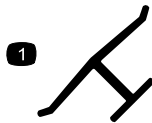

Manufacturer's Mark

1. Indicates the blade is identified as a part from the original machine manufacturer.

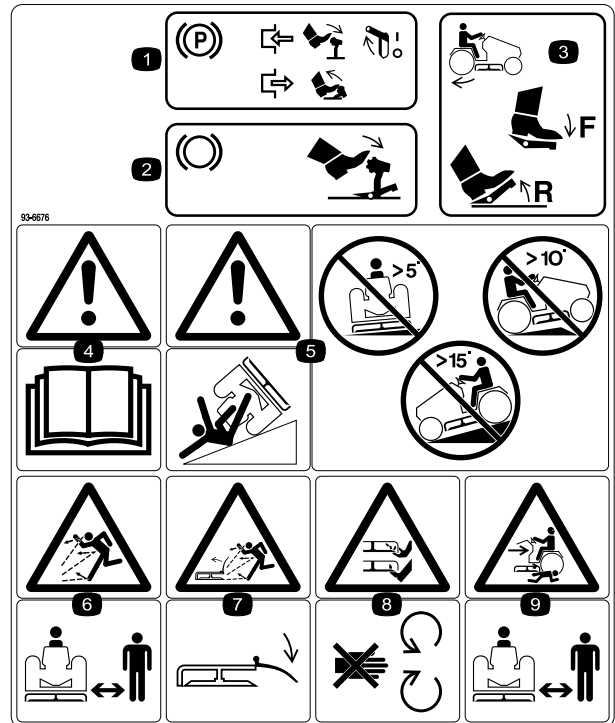

93-6676

1. Parking brake—to engage, press the brake/clutch pedal and lift the parking brake lever; to disengage press and release the brake/clutch pedal.
2. Brake and clutch—to engage, press the brake/clutch pedal.
3. Traction drive—to drive forward, press the top of the traction control pedal forward and down; to drive in reverse, press the bottom of the traction control pedal rearward and down.
4. Warning—read the *Operator's Manual*.
5. Warning—to avoid tipping the tractor, do not drive across slopes greater than 5 degrees, up slopes greater than 10 degrees, or down slopes greater than 15 degrees.
6. Thrown object hazard-keep bystanders a safe distance from the machine.
7. Thrown object hazard, mower—keep the deflector in place.
8. Cutting/dismemberment hazard of hand or foot, mower blade—stay away from moving parts.
9. Crushing/dismemberment of a bystander—keep bystanders a safe distance from the machine.

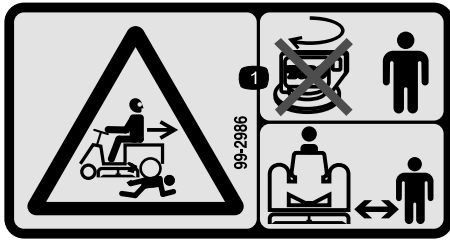

99-2986

1. Crushing/dismemberment hazard of bystanders—do not turn the key while children are present; keep children a safe distance from the machine.

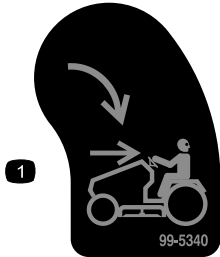

99-5340

1. KeyChoice—turn to enable reverse mowing.

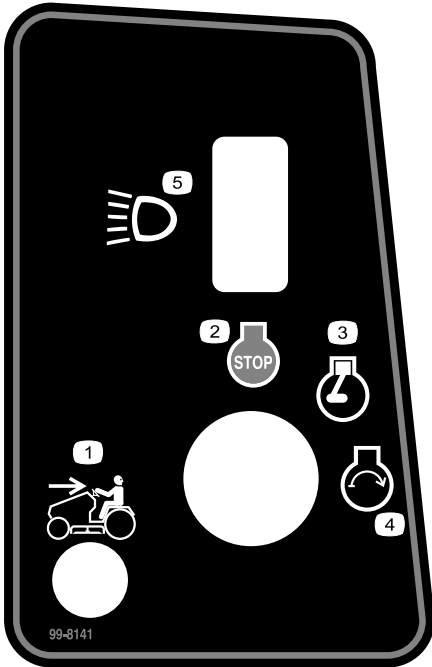

99-8141

- | | |
|------------------------------|-----------------|
| 1. Mowing in reverse enabled | 4. Engine—Start |
| 2. Engine—Stop | 5. Headlights |
| 3. Engine—Run | |

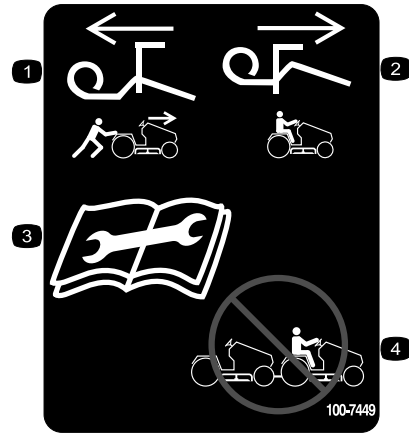

100-7449

- | | |
|--|--|
| 1. Pull the lever out to push the machine. | 3. Read the instructions before servicing or performing maintenance. |
| 2. Push the lever in to ride on the machine. | 4. Do not tow the machine. |

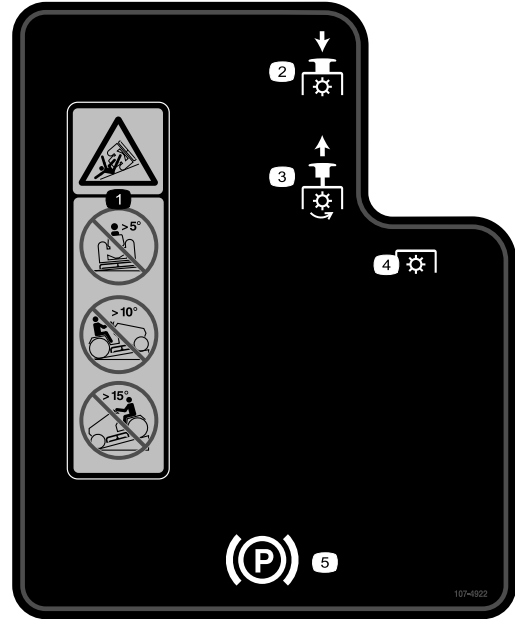

107-4922

1. Warning—to avoid tipping the tractor, do not drive across slopes greater than 5 degrees, up slopes greater than 10 degrees, or down slopes greater than 15 degrees.
2. Disengage
3. Engage
4. Power take-off (PTO)
5. Parking brake



Battery Symbols

Some or all of these symbols are on your battery

- | | |
|--|--|
| 1. Explosion hazard | 6. Keep bystanders a safe distance from the battery. |
| 2. No fire, open flame, or smoking. | 7. Wear eye protection; explosive gases can cause blindness and other injuries |
| 3. Caustic liquid/chemical burn hazard | 8. Battery acid can cause blindness or severe burns. |
| 4. Wear eye protection | 9. Flush eyes immediately with water and get medical help fast. |
| 5. Read the <i>Operator's Manual</i> . | 10. Contains lead; do not discard. |

Product Overview

Controls

Become familiar with the controls (Figure 4) before you start the engine and operate the tractor.

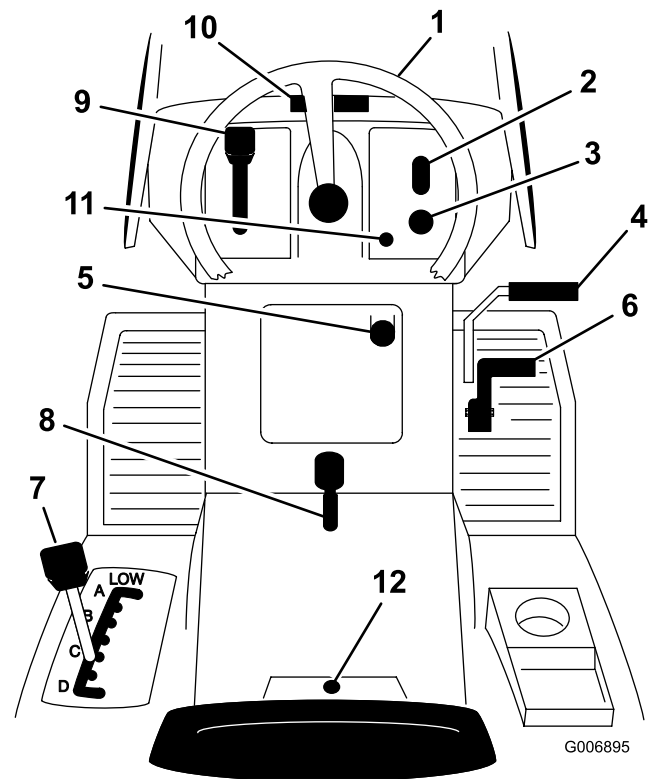

Figure 4

- | | |
|---------------------------|--------------------------------|
| 1. Steering wheel | 7. Height-of-cut lever |
| 2. Light switch—on/off | 8. Parking brake lever |
| 3. Ignition switch | 9. Throttle lever |
| 4. Clutch/brake pedal | 10. Hood opening |
| 5. Blade control (PTO) | 11. Operating-in-reverse light |
| 6. Traction control pedal | 12. KeyChoice® switch |

Specifications

| Model | Weight | Length | Width | Height |
|-------|--------------------|-------------------|-------------------|-------------------|
| 71253 | 370 lb (168 kg) | 68 in (173 cm) | 55 in (140 cm) | 42 in (107 cm) |

Operation

Note: Determine the left and right sides of the machine from the normal operating position.

Gasoline and Oil

Recommended Gasoline

Use unleaded regular gasoline suitable for automotive use (85 pump octane minimum). You may use leaded regular gasoline if unleaded regular is not available.

Important: Never use methanol, gasoline containing methanol, or gasohol containing more than 10% ethanol because the fuel system could be damaged. Do not mix oil with gasoline.



In certain conditions, gasoline is extremely flammable and highly explosive. A fire or explosion from gasoline can burn you and others and can damage property.

- Fill the fuel tank outdoors in an open area when the engine is cold. Wipe up any gasoline that spills.
- Do not fill the fuel tank completely full. Add gasoline to the fuel tank until the level is 1/4 to 1/2 inch (6 to 13 mm) below the bottom of the filler neck. This empty space in the tank allows the gasoline to expand.
- Never smoke when handling gasoline, and stay away from an open flame or where a spark may ignite the gasoline fumes.
- Store gasoline in an approved container and keep it out of the reach of children.
- Never buy more than a 30-day supply of gasoline.
- Always place gasoline containers on the ground away from your vehicle before filling.
- Do not fill gasoline containers inside a vehicle or on a truck or trailer bed because interior carpets or plastic truck bed liners may insulate the container and slow the loss of any static charge.
- When practical, remove gas-powered equipment from the truck or trailer and refuel the equipment with its wheels on the ground.
- If this is not possible, refuel such equipment on a truck or trailer from a portable container, not from a gasoline dispenser nozzle.
- If you must use a gasoline dispenser, keep the nozzle in contact with the rim of the fuel tank or container opening at all times until fueling is complete.

Using Stabilizer/Conditioner

Use a fuel stabilizer/conditioner in the tractor to provide the following benefits:

- It keeps gasoline fresh during storage for up to 90 days. For longer storage, drain the fuel tank.

- It cleans the engine while it runs.
- It eliminates gum-like varnish buildup in the fuel system, which causes hard starting.

Important: Do not use fuel additives containing methanol or ethanol.

Add the correct amount of fuel stabilizer/conditioner to the gasoline.

Note: A fuel stabilizer/conditioner is most effective when it is mixed with fresh gasoline. To minimize the chance of varnish deposits in the fuel system, use a fuel stabilizer/conditioner at all times.

Filling the Fuel Tank

1. Set the parking brake.
2. Stop the engine, remove the key, and wait for all moving parts to stop before leaving the operating position.
3. Clean around the fuel tank cap and remove the cap.
4. Add unleaded regular gasoline to the fuel tank until the level is 1/4 to 1/2 inch (6 to 13 mm) below the bottom of the filler neck. Do not fill the fuel tank completely full.

Note: This space in the tank allows gasoline to expand.

5. Install the fuel tank cap securely.
6. Wipe up any gasoline that spills.

Checking the Engine Oil Level

Service Interval: Before each use or daily

Before you start the engine and use the tractor, check the oil level in the engine crankcase; refer to Checking the Oil Level.

Using the Parking Brake

Always set the parking brake whenever you stop the tractor or leave it unattended.

Setting the Parking Brake

1. Push the brake pedal (Figure 5) down and hold it.

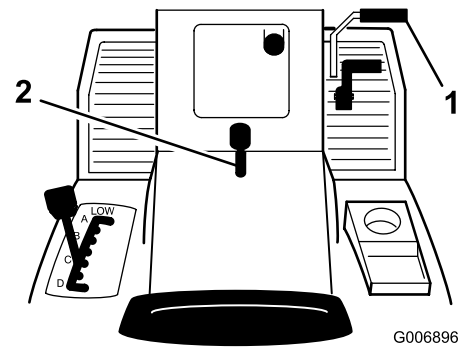

Figure 5

1. Brake pedal
2. Parking brake lever

2. Lift the parking brake lever (Figure 5) up and gradually take your foot off of the brake pedal.

Note: The brake pedal should stay in the depressed (locked) position.

Releasing the Parking Brake

1. Push down on the brake pedal (Figure 5).

Note: The parking brake lever should release.

2. Gradually release the brake pedal.

Positioning the Seat

The seat can move forward and backward. Position the seat where you have the best control of the tractor and are most comfortable.

1. Raise the seat and loosen the adjustment knobs (Figure 6).

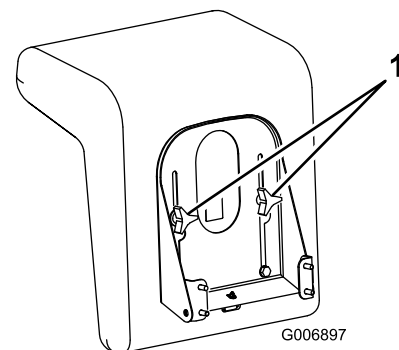

Figure 6

1. Adjustment knobs

2. Move the seat to the desired position and tighten the knobs.

Operating the Headlights

A dash-mounted On/Off switch (Figure 4) controls the headlights. The lights only shine while the engine is running and the switch is On.

Operating the Blade Control (PTO)

The blade control (PTO) engages and disengages power to the electric clutch.

Engaging the Power Take Off (PTO)

1. Press the clutch/brake pedal to stop the tractor.
2. Pull the blade control (PTO) to on (Figure 7).

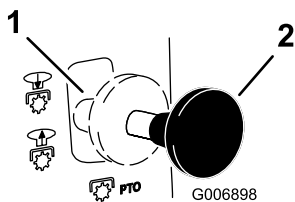

Figure 7

1. Off—disengaged
2. On—engaged

Disengaging the Blade Control (PTO)

1. Press the clutch/brake pedal to stop the tractor.
2. Push the blade control (PTO) to off (Figure 7).

Setting the Height-of-Cut

Use the height-of-cut lever to raise and lower the mower to the desired cutting height. You can set the height-of-cut to one of seven positions from approximately 1-1/2 to 4-1/2 inches (38 to 116 mm).

1. Park the machine on a level surface.
2. Disengage the blade control (PTO).
3. Set the parking brake.
4. Stop the engine, remove the key, and wait for all moving parts to stop before leaving the operating position.
5. Pull on the height-of-cut lever on the tractor and move it to the desired position (Figure 8).

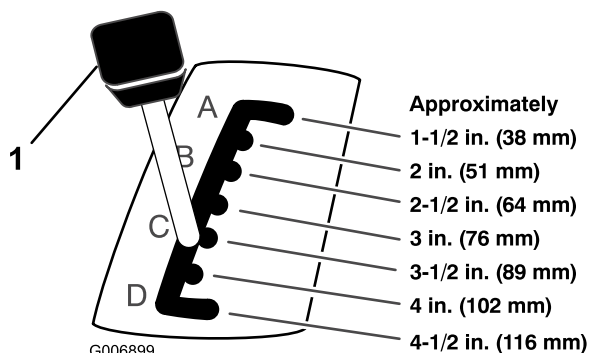

Figure 8

1. Height-of-cut lever

Starting the Engine

1. Sit down on the seat.
2. Set the parking brake; refer to Setting the Parking Brake.

Note: The engine does not start unless you set the parking brake or fully depress the brake pedal.

3. Push the blade control (PTO) to off (Figure 7).
4. Shift the throttle lever to Choke (Figure 9).

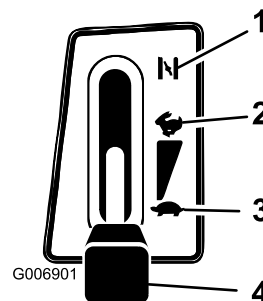

Figure 9

1. Choke
2. Fast
3. Slow
4. Throttle lever

Note: An engine that has been running and is warm may not require step 4.

5. Turn the ignition key clockwise and hold it in the Start position (Figure 10). When the engine starts, release the key.

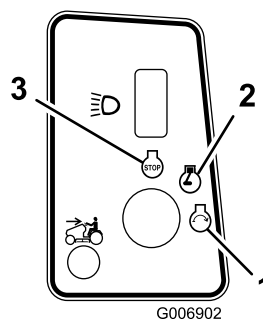

Figure 10

1. Start
2. On
3. Off

Important: If the engine does not start after 30 seconds of continuous cranking, turn the ignition key to Off and let the starter motor cool; refer to Troubleshooting.

6. After the engine starts, slowly shift the throttle lever to Fast (Figure 9). If the engine stalls or hesitates, shift the throttle lever back to Choke for a few seconds and then shift the throttle lever to Fast. Repeat this step as required.

Stopping the Engine

1. Shift the throttle lever to Fast (Figure 9).
2. Turn the ignition key to Off, wait for all moving parts to stop, and remove the key before leaving the operating position. (Figure 10).

Using the Safety Interlock System

Service Interval: Before each use or daily



If the safety interlock switches are disconnected or damaged, the tractor could operate unexpectedly, causing personal injury.

- Do not tamper with the interlock switches.
- Check the operation of the interlock switches daily and replace any damaged switches before operating the tractor.

Understanding the Safety Interlock System

The safety interlock system is designed to prevent the engine from starting unless:

- You are sitting on the seat.
- The brake pedal is depressed.
- The blade control (PTO) is in the Disengage position.

The safety interlock system is designed to stop the engine if you do the following:

- You rise from the seat when the brake pedal is released.
- You rise from the seat while the blade control (PTO) is in the Engage position.
- You shift into reverse while the blade control (PTO) is in the Engage position.

Setting the KeyChoice Switch to Operate in Reverse

An interlock feature on the tractor prevents the power take-off (PTO) from operating when you back up the tractor. If you shift the traction control switch into Reverse with the blade control (PTO) engaged (i.e., with the mower blades or other attachment running),

the engine will stop. **Do not mow in reverse unless it is absolutely necessary.**

If you need to use the blade control (PTO) while backing up, turn off the interlock feature using the KeyChoice switch located near the seat bracket (Figure 11).

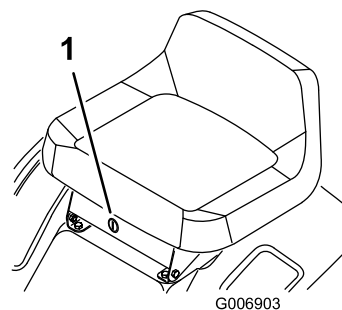

Figure 11

1. KeyChoice switch



You could back over a child or bystander while the mower blades or other attachment is engaged and cause serious injury or death.

- Do not mow in reverse unless it is absolutely necessary.
- Do not insert the KeyChoice key unless it is absolutely necessary.
- Always look backward and down before backing up.
- Use the KeyChoice switch only if you are certain no children or other bystanders will enter the mowing area.
- Be very observant after deactivating the interlock because the sound of the engine may prevent you from noticing that a child or bystander has entered the work area.
- Always remove both the ignition and KeyChoice keys and put them in a safe place out of the reach of children or unauthorized users when leaving the tractor unattended.

1. Engage the blade control (PTO).
2. Insert the KeyChoice key into the switch (Figure 11).
3. Turn the KeyChoice key.

Note: A red light on the front console (Figure 12) turns on, indicating that the interlock is disabled.

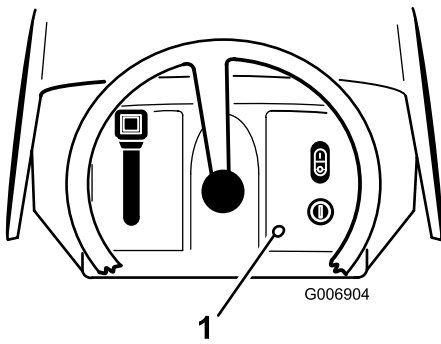

Figure 12

1. Operating-in-reverse light

4. Shift the traction control switch into Reverse and complete your task.
5. Disengage the blade control (PTO) to activate the interlock.
6. Remove the KeyChoice key and put it in a safe place out of the reach of children.

Testing the Safety Interlock System



If safety interlock switches are disconnected or damaged, the tractor could operate unexpectedly, causing personal injury.

- Do not tamper with the interlock switches.
- Check the operation of the interlock switches daily and replace any damaged switches before operating the tractor.
- Replace switches every 2 years regardless of whether they are operating properly or not.

Test the safety system before you use the tractor each time. If the safety interlock system does not operate as described below, have an Authorized Service Dealer repair the safety interlock system immediately. While sitting in the seat, perform the following checks:

1. Set the parking brake. Shift the blade control (PTO) to Engage, and turn the ignition key to Start: The engine should not crank.
2. Shift the blade control (PTO) to Disengage and release the parking brake. Turn the ignition key to Start: The engine should not crank.
3. With the ground speed in Neutral, set the parking brake, shift the blade control (PTO) to Disengage, and start the engine. While the engine is running,

release the parking brake and rise slightly from the seat: The engine should stop.

4. Shift the blade control (PTO) to Disengage, move the traction control pedal to Neutral, set the parking brake, and start the engine. While the engine is running, shift the blade control (PTO) switch to Engage and move the traction control pedal to Reverse: The engine should stop.
5. Shift the blade control (PTO) to Disengage, move the traction control pedal to Neutral, and set the parking brake. Start the engine, shift the blade control (PTO) switch to Engage, and turn the KeyChoice key and release it: The operating-in-reverse warning light should illuminate.
6. Shift the blade control (PTO) to Disengage: The operating-in-reverse warning light should turn off.

Pushing the Tractor Manually

Important: Always push the tractor manually. Never tow the tractor because you may damage the transaxle.

To Push the Tractor

1. Disengage the blade control (PTO).
2. Stop the engine, remove the key, and wait for all moving parts to stop before leaving the operating position.
3. Pull the drive control out to the Push position.

Note: This disengages the drive system and allows the wheels to turn freely (Figure 13).

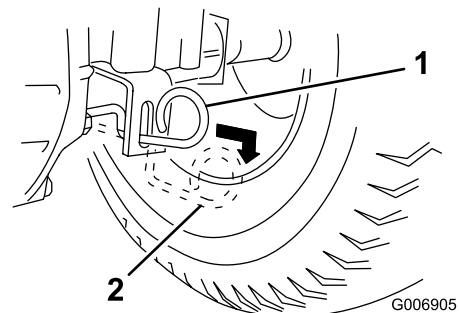

Figure 13

1. Operate position
2. Push position

To Operate the Tractor

Push the drive control into the Operate position. This engages the drive system (Figure 13).

Note: The tractor will not drive unless the drive control is in the Operate position.

Driving Forward or Backward

The throttle control regulates the engine speed as measured in RPM (revolutions per minute). Shift the throttle control lever into the Fast position for best performance.

To go forward or backward:

1. Release the parking brake; refer to Releasing the Parking Brake.
2. Place your foot on the traction control pedal and slowly press on the top of the traction control pedal to move forward or on the bottom of the pedal to move backward (Figure 14).

Note: The farther you move the traction control pedal in either direction, the faster the tractor will move in that direction.

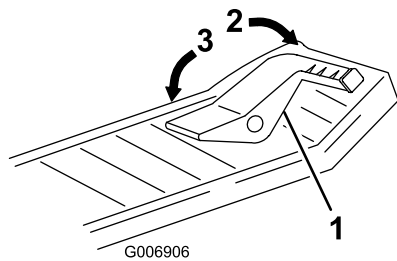

Figure 14

1. Traction control pedal
2. Forward
3. Backward

Note: To slow down, release the pressure on the traction control pedal.

Important: To avoid transmission damage, always release the parking brake before moving the traction control pedal.

Note: To reverse the tractor with the blade control (PTO) engaged, deactivate the operating-in-reverse interlock using the KeyChoice switch located in front of and below the seat.

Stopping the Tractor

1. Release the traction control pedal.
2. Disengage the blade control (PTO).
3. Turn the ignition key to Off to stop the engine.
4. Set the parking brake if you leave the tractor unattended; refer to Setting the Parking Brake.
5. Remove the ignition key from the switch.



Children or bystanders may be injured if they move or attempt to operate the tractor while it is unattended.

Always remove the ignition and KeyChoice keys and set the parking brake when leaving the tractor unattended, even if just for a few minutes.

Operating Tips

- For the best performance, operate the engine at the maximum speed. The mower requires air to thoroughly cut grass clippings, so do not set the height-of-cut too low or completely surround the mower in uncut grass. Always leave one side of the mower free from uncut grass to allow the air to be drawn into the mower.
- Cut the grass slightly longer than normal to ensure that the cutting height of the mower does not scalp any uneven ground. When cutting grass longer than 6 inch (15 cm) tall, cut the lawn twice to ensure an acceptable appearance.
- It is best to cut only about 1/3 of the grass blade. Do not cut more than that unless the grass is sparse or it is late fall when grass grows more slowly.
- Alternate the mowing direction to keep the grass standing straight. This also helps disperse clippings and enhances decomposition and fertilization.
- Grass grows at different rates at different times of the season. To maintain the same cutting height, which is a good practice, mow more often in early spring. As the grass growth rate slows in mid summer, mow less frequently.
- To improve the quality of cut, use a slower ground speed. For best operation on average lawns, operate the engine at full throttle while controlling the ground speed. You should operate the tractor between 2 to 3.5 mph (3.2 to 5.6 km/h) while mowing.
- If the grass is longer than normal, or if it contains a high degree of moisture, raise the cutting height higher than usual, cut the grass at that setting, and then cut the grass again at the lower, normal setting.
- If you must stop the tractor while mowing, you may leave a clump of grass clippings on your lawn. To avoid this, do the following:
 - Engage the blade and move to a previously cut area.

- Disperse the clippings evenly by raising the mower 1 or 2 height-of-cut settings while driving forward with the blade engaged.
- Use the washout port to clean clippings and dirt from the underside of the mower after each use. If grass and dirt build up inside the mower, the cutting quality will eventually become unsatisfactory.
- Maintain a sharp blade throughout the season. A sharp blade cuts grass cleanly without tearing or shredding the grass blades. Tearing and shredding the grass turns it brown at the edges, which slows its growth and increases the chance of disease. Every 30 days, check the blade for sharpness and file down any nicks.

Maintenance

Note: Determine the left and right sides of the machine from the normal operating position.

Recommended Maintenance Schedule(s)

| Maintenance Service Interval | Maintenance Procedure |
|------------------------------|--|
| After the first 5 hours | <ul style="list-style-type: none"> • Change the engine oil. |
| Before each use or daily | <ul style="list-style-type: none"> • Check the engine oil level. • Check the safety system. • Check the oil level. • Check the battery electrolyte. • Check the parking brake. • Wash the underside of the mower. |
| Every 25 hours | <ul style="list-style-type: none"> • Grease and lubricate the tractor. More often in dusty or dirty conditions. • Clean the air cleaner foam element. • Service the spark plug. • Check the tire pressure. |
| Every 50 hours | <ul style="list-style-type: none"> • Change the engine oil. Change it more often under a heavy load or in high temperatures. |
| Every 100 hours | <ul style="list-style-type: none"> • Change the oil filter. • Replace the air cleaner paper element. • Replace the spark plug. • Replace the fuel filter. • Service the transaxle fluid. • Clean the cooling system. |
| Before storage | <ul style="list-style-type: none"> • Drain the fuel tank. • Perform all the maintenance procedures listed above. • Paint any chipped surfaces. • Check the tire pressure. • Check the safety system. • Check the brakes. • Check the spark plug. • Check the battery electrolyte. • Charge the battery and disconnect the cables. • Check the belt(s) for wear and cracks. |

Important: Refer to your engine operator's manual for additional maintenance procedures.



If you leave the key in the ignition switch, someone could accidentally start the engine and seriously injure you or other bystanders.

Remove the key from the ignition and disconnect the wire from the spark plug before you do any maintenance. Set the wire aside so that it does not accidentally contact the spark plug.

Lubrication

Greasing and Lubricating the Tractor

Service Interval: Every 25 hours—Grease and lubricate the tractor. More often in dusty or dirty conditions.

How to Grease the Tractor

1. Disengage the blade control (PTO).
2. Set the parking brake.
3. Stop the engine, remove the key, and wait for all moving parts to stop before leaving the operating position.
4. Clean the grease fittings with a rag.

Note: Ensure that you scrape any paint off the front of the fittings.

5. Connect a grease gun to each fitting and pump grease into it.
6. Wipe up any excess grease.

Where to Add Grease

Lubricate the front wheels and steering spindles until grease begins to ooze out of the bearings (Figure 15).

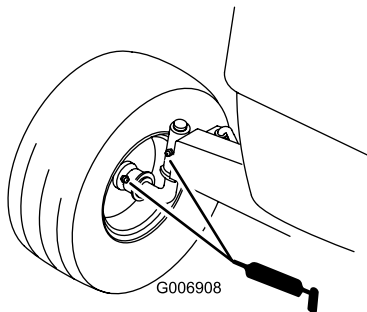

Figure 15

Engine Maintenance

Servicing the Engine Oil

Oil Type: Detergent oil (API service SF, SG, SH, SJ, or higher)

Crankcase Capacity: 48 oz. or 1-1/2 qt. (1400 cc or 1.4 l) when the filter is not changed; 56 oz. or 1-3/4 qt. (1700 cc or 1.7 l) when the filter is changed.

Viscosity: See the table below.

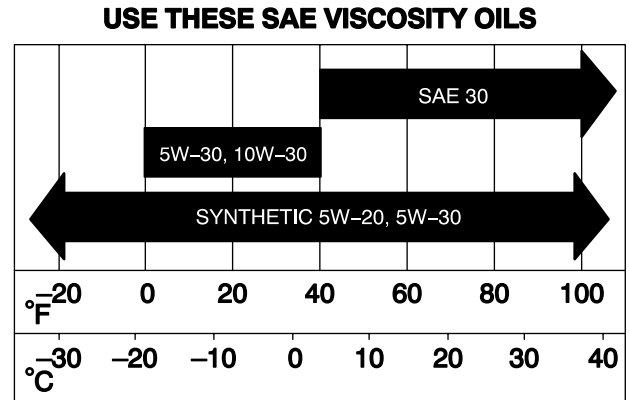

Figure 16

Checking the Oil Level

Service Interval: Before each use or daily

1. Park the tractor on a level surface.
2. Disengage the blade control (PTO).
3. Set the parking brake.
4. Stop the engine, wait for all moving parts to stop, and remove the key before leaving the operating position.
5. Open the hood.
6. Clean around the oil dipstick (Figure 17) so that dirt cannot fall into the fill hole and damage the engine.

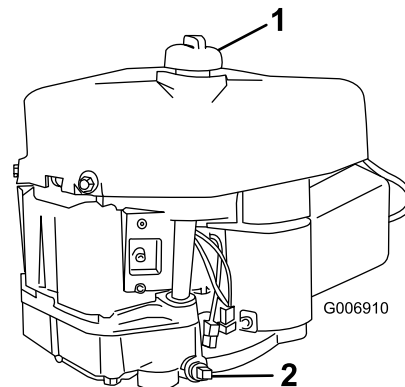

Figure 17

1. Oil dipstick/fill hole
2. Oil drain plug

- Unscrew the oil dipstick and wipe the metal end clean (Figure 18).

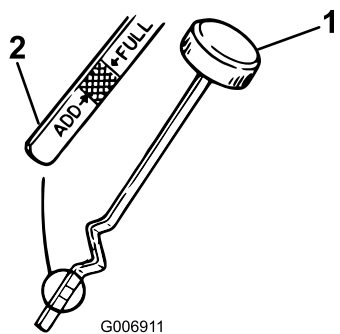

Figure 18

- Oil dipstick
- Metal end

- Screw the oil dipstick fully onto the fill hole.
- Unscrew the dipstick again and look at the metal end. If the oil level is low, slowly pour only enough oil into the fill hole to raise the level to the Full mark on the dipstick.

Important: Do not overfill the crankcase with oil and run the engine; the engine damage may result.

Changing the Oil

Service Interval: After the first 5 hours

Every 50 hours Change it more often under a heavy load or in high temperatures.

- Start the engine and let it run for 5 minutes.

Note: This warms the oil so that it will drain more easily.
- Park the tractor so that the left side is slightly lower than the right side to ensure that the oil drains completely.
- Disengage the blade control (PTO).
- Set the parking brake.
- Stop the engine, wait for all moving parts to stop, and remove the key before leaving the operating position.
- Open the hood.
- Place a drain pan below the oil drain plug and remove it (Figure 17).
- When the oil has drained completely, install the oil drain plug.

Note: Dispose of the used oil at a certified recycling center.

- Change the oil filter, if necessary. Refer to Changing the Oil Filter.
- Slowly pour approximately 80% of the specified amount of oil into the fill hole (Figure 17). Check the oil level; refer to 4 and 5 of Checking the Oil Level.

Changing the Oil Filter

Service Interval: Every 100 hours

Note: Change the oil filter more frequently when the operating conditions are extremely dusty or sandy.

- Drain the oil from the engine; refer to Changing and Draining the Oil.
- Remove the old oil filter and wipe the filter adapter (Figure 19) gasket surface.

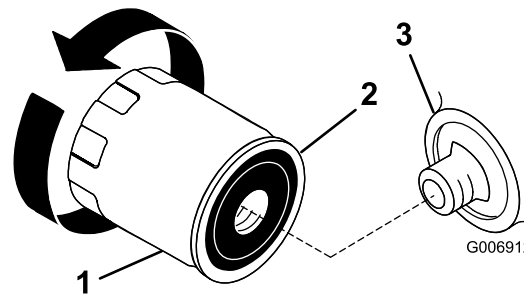

Figure 19

- Oil filter
- Gasket
- Filter adapter

- Apply a thin coat of new oil to the rubber gasket on the new oil filter (Figure 19).
- Install the new oil filter to the filter adapter.
- Turn the oil filter clockwise until the rubber gasket contacts the filter adapter, then tighten the oil filter an additional 1/2 to 3/4 turn (Figure 19).
- Slowly pour about 80% of the specified amount of oil into the fill hole (Figure 17). Check the oil level; refer to 7 and 8 of Checking the Oil Level.
- Close the hood.

Servicing the Air Cleaner

Service Interval: Every 25 hours—Clean the air cleaner foam element.

Every 100 hours—Replace the air cleaner paper element.

Note: Service the air cleaner more frequently if the operating conditions are extremely dusty or sandy.

Removing the Foam and Paper Elements

- Disengage the blade control (PTO).

2. Set the parking brake.
3. Stop the engine, wait for all moving parts to stop, and remove the key before leaving the operating position.
4. Open the hood.
5. Clean around the air cleaner to prevent dirt from getting into the engine and causing damage.
6. Pull up on the air cleaner cover handle and rotate it toward the engine (Figure 20).

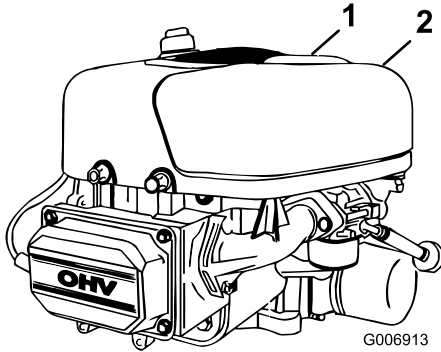

Figure 20

1. Air cleaner cover
2. Air cleaner cover handle

Note: Remove the air cleaner cover.

7. Carefully slide the paper element and the foam element from the blower housing (Figure 21).

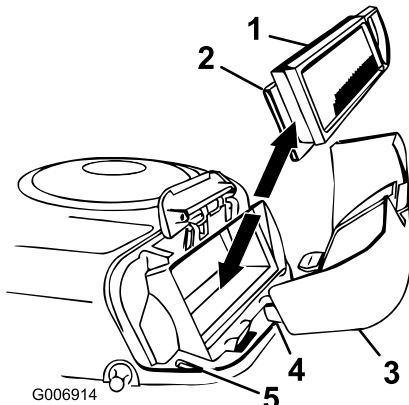

Figure 21

1. Paper element
2. Foam element
3. Air cleaner cover
4. Tab
5. Slot

Cleaning the Foam and Paper Elements

Foam Element:

1. Wash the foam element in liquid soap and warm water. When the element is clean, rinse it thoroughly.
2. Dry the element by squeezing it in a clean cloth. **Do not oil the element.**

Important: Replace the foam element if it is torn or worn.

Paper Element:

1. Lightly tap the element on a flat surface to remove dust and dirt.
2. Carefully clean the rubber seal on the paper element to prevent debris from entering the engine.
3. Inspect the element for tears, an oily film, and damage to the rubber seal.

Important: Never clean the paper element with pressurized air or liquids such as solvents, gasoline, or kerosene. Replace the paper element if it is damaged or cannot be cleaned thoroughly.

Installing the Foam and Paper Elements

Important: To prevent engine damage, always operate the engine with the complete foam and paper air cleaner assembly installed.

1. Place the foam element and paper element into the blower housing.

Note: Make sure that the rubber seal is flat against the air cleaner base.

2. Align the tabs on the air cleaner cover with the slots of the blower housing (Figure 21).
3. Hook the handle onto the cover and press down on the handle to lock the cover in place.
4. Close the hood.

Servicing the Spark Plug

Service Interval: Every 25 hours—Service the spark plug.

Every 100 hours—Replace the spark plug.

Use a **Champion QC12YC** or equivalent spark plug. Make sure that the air gap between the center and side electrodes is 0.030 inch (0.76 mm) before installing the spark plug. Use a spark plug wrench for removing and installing the spark plug and a gapping tool/feeler gauge to check and adjust the air gap.

Removing the Spark Plug

1. Disengage the blade control (PTO).
2. Set the parking brake.
3. Stop the engine, wait for all moving parts to stop, and remove the key before leaving the operating position.
4. Open the hood.
5. Disconnect the wire from the spark plug (Figure 22).

Fuel System Maintenance

Draining the Fuel Tank

Service Interval: Before storage

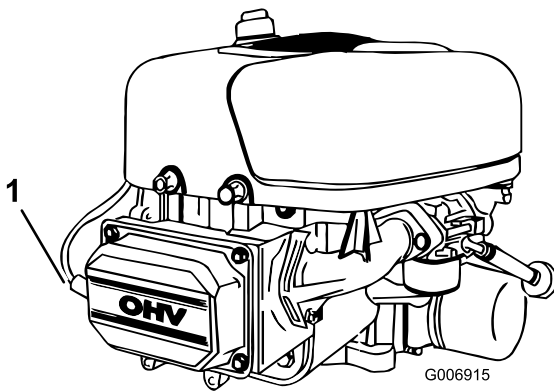

Figure 22

1. Spark-plug wire

6. Clean around the spark plug to prevent dirt from falling into the engine and potentially causing damage.
7. Remove the spark plug and metal washer.

Checking the Spark Plug

1. Look at the center of the spark plug (Figure 23). If you see light brown or gray on the insulator, the engine is operating properly. A black coating on the insulator usually means the air cleaner is dirty.

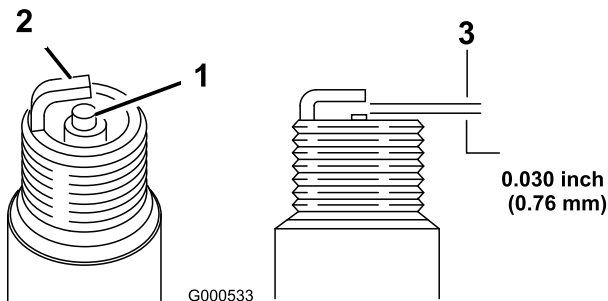

Figure 23

1. Center electrode insulator
2. Side electrode
3. Air gap (not to scale)

Important: Never clean the spark plug. Always replace the spark plug when it has a black coating, worn electrodes, an oily film, or cracks.

2. Check the gap between the center and side electrodes (Figure 23). Bend the side electrode if the gap is not correct.

Installing the Spark Plug

1. Install the spark plug and metal washer.

Note: Ensure that the air gap is set correctly.

2. Tighten the spark plug to 15 ft-lb (20 N·m).
3. Connect the wire to the spark plug (Figure 22).
4. Close the hood.



In certain conditions, gasoline is extremely flammable and highly explosive. A fire or explosion from gasoline can burn you and others and can damage property.

- Drain gasoline from the fuel tank when the engine is cold. Do this outdoors in an open area. Wipe up any gasoline that spills.
- Never smoke when draining gasoline, and stay away from an open flame or where a spark may ignite the gasoline fumes.

1. Park the tractor so that the left front side is slightly lower than the right side to ensure that the fuel tank drains completely.
2. Disengage the blade control (PTO).
3. Set the parking brake.
4. Stop the engine, wait for all moving parts to stop, and remove the key before leaving the operating position.
5. Open the hood and locate the fuel filter (Figure 24).

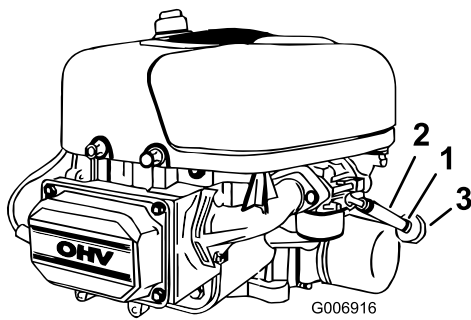

Figure 24

1. Hose clamp
2. Fuel line
3. Fuel filter

6. Squeeze the ends of the hose clamp together and slide it up the fuel line toward the fuel tank (Figure 24).
7. Pull the fuel line off of the fuel filter (Figure 24) and allow gasoline to drain into a fuel container or a drain pan.

Note: Now is the best time to install a new fuel filter because the fuel tank is empty.

8. Install the fuel line onto the fuel filter.
9. Slide the hose clamp close to the fuel filter to secure both the fuel line and the fuel filter.

Replacing the Fuel Filter

Service Interval: Every 100 hours—Replace the fuel filter.

The best time to replace the fuel filter (Figure 24) is when the fuel tank is empty. Never install a dirty fuel filter after it has been removed from the fuel line.

1. Disengage the blade control (PTO) and set the parking brake.
2. Stop the engine, wait for all moving parts to stop, and remove the key before leaving the operating position.
3. Open the hood.
4. Squeeze the ends of the hose clamps together and slide them away from the fuel filter (Figure 24).
5. Remove the fuel filter from the fuel lines.
6. Install a new fuel filter and move the hose clamps close to the fuel filter.
7. Close the hood.

Electrical System Maintenance

Servicing the Battery

Always keep the battery clean and fully charged. Use a paper towel to clean the battery and battery box. If the battery terminals are corroded, clean them with a solution of 4 parts water and 1 part baking soda. Apply a light coating of grease to the battery terminals to prevent corrosion.

Battery voltage and amperage: 12 volts, 155 cold-cranking amps

Removing the Battery



Battery terminals or metal tools could short against metal tractor components, causing sparks. Sparks can cause the battery gasses to explode, resulting in personal injury.

- When removing or installing the battery, do not allow the battery terminals to touch any metal parts of the tractor.
- Do not allow metal tools to short between the battery terminals and metal parts of the tractor.

1. Disengage the blade control (PTO) and set the parking brake.
2. Stop the engine, remove the key, and wait for all moving parts to stop before leaving the operating position.
3. Tip the seat forward to see the battery.
4. Disconnect the negative (black) ground cable from the battery post (Figure 25).

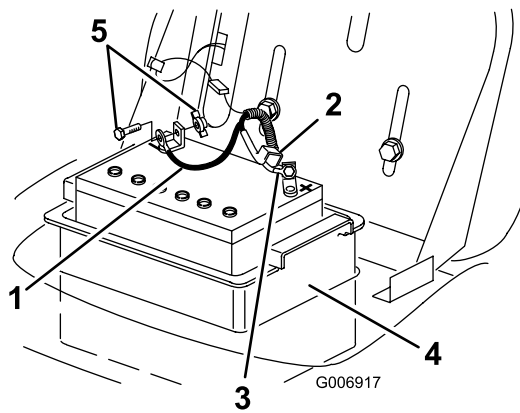

Figure 25

- | | |
|---------------------------|----------------------|
| 1. Negative cable (black) | 4. Battery box |
| 2. Rubber cover | 5. Bolt and wing nut |
| 3. Positive cable (red) | |

2. Look at the side of the battery. The electrolyte must be up to the Upper line (Figure 26).

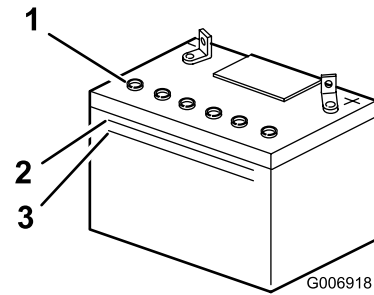

Figure 26

- | | |
|---------------|---------------|
| 1. Vent caps | 3. Lower line |
| 2. Upper line | |

Note: Do not allow the electrolyte to fall below the Lower line (Figure 26).

3. If the electrolyte is low, add the required amount of distilled water; refer to Adding Water to the Battery.



Incorrectly routing the battery cable could damage the tractor and cables, causing sparks. Sparks can cause the battery gasses to explode, resulting in personal injury.

- Always *disconnect* the negative (black) battery cable before disconnecting the positive (red) cable.
- Always *connect* the positive (red) battery cable before connecting the negative (black) cable.

5. Slide the rubber cover up the positive (red) cable. Disconnect the positive (red) cable from the battery post (Figure 25).
6. Remove the battery box and battery from the chassis (Figure 25).

Installing the Battery

1. Put the battery into the battery box and install it into the chassis (Figure 25).
2. Using the bolt and wing nut, connect the positive (red) cable to the positive (+) battery post (Figure 25).
3. Slide the rubber cover over the battery post.
4. Using the bolt and the wing nut, connect the negative (black) cable to the negative (-) battery post (Figure 25).

Checking the Electrolyte Level

Service Interval: Before each use or daily

1. Tip the seat forward to see the battery.



Battery electrolyte contains sulfuric acid, a deadly poison that can severely burn you and others.

- Do not drink electrolyte and avoid contact with skin, eyes, or clothing. Wear safety glasses to shield your eyes and rubber gloves to protect your hands.
- Fill the battery where clean water is always available for flushing the skin.

Adding Water to the Battery

The best time to add distilled water to the battery is just before you operate the tractor. This lets the water mix thoroughly with the electrolyte solution.

1. Remove the battery from the tractor; refer to Removing the Battery.
2. Clean the top of the battery with a paper towel.

Important: Never fill the battery with distilled water while the battery is installed in the tractor. You could spill electrolyte on other parts and cause corrosion.

3. Remove the vent caps from the battery (Figure 26).
4. Slowly pour distilled water into each battery cell until the electrolyte level is up to the Upper line (Figure 26) on the battery case.

Important: Do not overfill the battery because electrolyte (sulfuric acid) can cause severe corrosion and damage to the chassis.

5. Wait 5 to 10 minutes after filling the battery cells. Add distilled water, if necessary, until the electrolyte level is up to the Upper line (Figure 26) on the battery case.
6. Install the battery vent caps.

Charging the Battery



Charging the battery produces gasses that can explode.

Never smoke near the battery. Keep sparks and flames away from battery.

Important: Always keep the battery fully charged (1.260 specific gravity), especially when the temperature is below 32°F (0°C) to prevent battery damage.

1. Remove the battery from the chassis; refer to Removing the Battery.
2. Check the electrolyte level; refer to Checking the Electrolyte Level.
3. Make sure that the vent caps are installed in the battery, and charge it for 1 hour at 25 to 30 amps or 6 hours at 4 to 6 amps. **Do not overcharge the battery.**
4. When the battery is fully charged, unplug the charger from the electrical outlet.
5. Disconnect the charger leads from the battery posts (Figure 27).

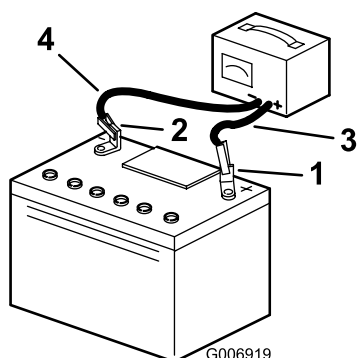

Figure 27

- | | |
|--------------------------|---------------------------|
| 1. Positive battery post | 3. Red (+) charger lead |
| 2. Negative battery post | 4. Black (-) charger lead |

Note: Do not run the tractor with the battery disconnected; electrical damage may occur.

Servicing the Fuse

The electrical system is protected by 10 amp, blade-type fuses.

1. Pull up on the fuse (Figure 28) to remove it from the socket.

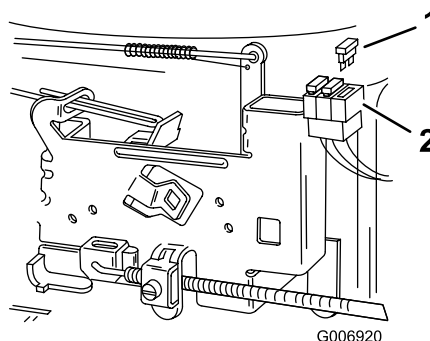

Figure 28

- | | |
|---------|-----------|
| 1. Fuse | 2. Socket |
|---------|-----------|

2. Insert the fuse into socket and push down on the fuse to install it.

6. Install the battery in the tractor and connect the battery cables; refer to Installing the Battery.

Drive System Maintenance

Servicing the Transaxle Fluid

Service Interval: Every 100 hours—Service the transaxle fluid.

Always keep the fluid level at the full level when the transaxle is cold.

Note: The transaxle is factory sealed and does not require oil changes.

Fluid Type: SAE 20W-50 engine oil (API service SH/CD is recommended)

Checking the Fluid Level

1. Park the tractor on a level surface.
2. Disengage the blade control (PTO) and set the parking brake.
3. Stop the engine, remove the key, and wait for all moving parts to stop before leaving the operating position.
4. Clean around the fill plug (Figure 29) so that dirt cannot fall into the reservoir if you need to add fluid.

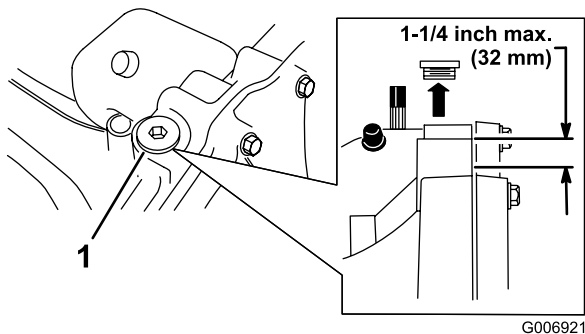

Figure 29

1. Fill plug

5. Remove the fill plug and check the fluid level.

Note: The level should be a maximum of 1-1/4 inch (32 mm) below the top of the fill port (Figure 29). Add fluid if necessary.

6. Install the fill plug.

Cooling System Maintenance

Cleaning the Cooling System

Service Interval: Every 100 hours

Use a dry brush to clean grass and accumulated debris from the engine daily.

Important: To prevent contaminating the fuel system, do not use water to clean the engine.

Brake Maintenance

Servicing the Parking Brake

Service Interval: Before each use or daily

The parking brake is on the right side of the rear axle, inside the rear tire (Figure 30). If the parking brake does not hold securely, adjust it.

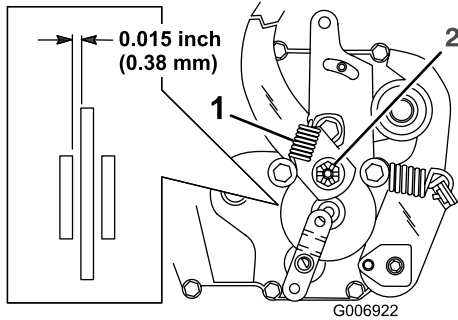

Figure 30

1. Brake arm spring 2. Brake adjusting nut

6. Install a new cotter pin and attach the brake arm spring.
7. Check the parking brake operation again; refer to Checking the Parking Brake.

Important: With the parking brake released, the rear wheels must rotate freely when you push the tractor. If you cannot achieve the .015 inch (0.38 mm) clearance and free wheel rotation, contact an Authorized Service Dealer immediately.

Checking the Parking Brake

1. Park the tractor on a level surface.
2. Disengage the blade control (PTO) and set the parking brake.
3. Stop the engine, remove the key, and wait for all moving parts to stop before leaving the operating position.
4. Move the drive control wire to the Push position; refer to Pushing the Tractor Manually.
5. If the rear wheels lock and skid when you push the tractor forward, you do not need to adjust the parking brake. Adjust the parking brake if the wheels turn and do not lock; refer to Adjusting the Parking Brake.

Adjusting the Parking Brake

1. Check the parking brake before you adjust it; refer to Checking the Brake.
2. Remove the brake arm spring (Figure 30).
3. Remove the cotter pin that secures the brake adjusting nut and slightly loosen the nut (Figure 30).
4. Insert a 0.015 inch (0.38 mm) feeler gauge between the brake disc and brake puck (Figure 30).
5. Tighten the nut until you feel a slight resistance on the feeler gauge when you slide it in and out.

Checking the Tire Pressure

Service Interval: Every 25 hours

Maintain the air pressure in the front and rear tires at 20 psi (138 kPa). Check the pressure at the valve stem (Figure 31) after every 25 operating hours or yearly, whichever occurs first. Check the tires when they are cold to get the most accurate pressure reading.

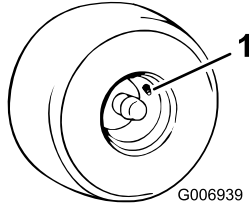

Figure 31

1. Valve stem

Servicing the Headlights

The headlights use an 1156, automotive-type bulb.

Removing the Bulb

1. Open the hood.
2. Disconnect the wire connectors from both of the bulb holder terminals.
3. Rotate the bulb holder 1/4 turn counterclockwise and remove it from the reflector (Figure 32).

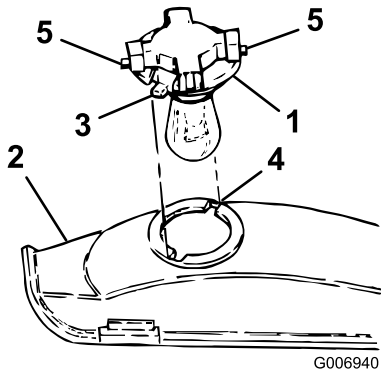

Figure 32

1. Bulb holder
2. Reflector
3. Tabs
4. Slots
5. Terminals

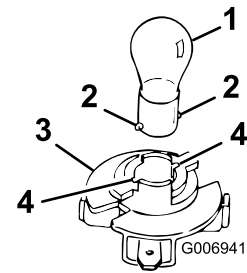

Figure 33

1. Bulb
2. Metal pins
3. Bulb holder
4. Slots

Installing the Bulb

1. Align the metal pins on the side of the bulb base with the slots in the bulb holder.
2. Insert the base into the holder (Figure 33).
3. Push and rotate the bulb clockwise until it stops.
4. Align the tabs on the bulb holder (Figure 32) with the slots in the reflector, insert the bulb holder into the reflector, and rotate it 1/4 turn clockwise until it stops.
5. Connect the wire connectors to the terminals on the bulb holder.

4. Insert and rotate the bulb counterclockwise until it stops (approx. 1/4 turn), and remove the bulb from the bulb holder (Figure 33).

Cleaning

Washing the Underside of the Mower

Service Interval: Before each use or daily

Wash the underside of the mower to prevent grass buildup for improved mulch action and clipping dispersal.

1. Park the tractor on a level surface.
2. Disengage the blade control (PTO) and set the parking brake.
3. Stop the engine, remove the key, and wait for all moving parts to stop before leaving the operating position.
4. Attach the coupling (not included) to the mower washout fitting and turn the water on high (Figure 34).

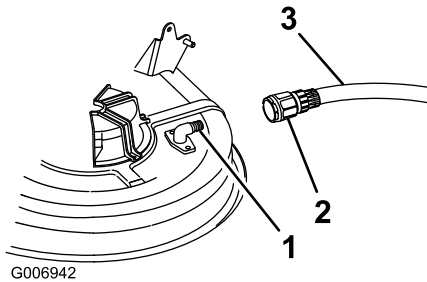

Figure 34

- | | |
|----------------------------|---------|
| 1. Washout fitting | 3. Hose |
| 2. Coupling (not included) | |

Note: Spread petroleum jelly on the washout fitting o-ring to make the coupling slide on easier and protect the o-ring.

5. Lower the mower to the lowest height of cut.
6. Sit on the seat and start the engine.
7. Engage the blade control (PTO) and let the mower run for 1 to 3 minutes.
8. Disengage the blade control (PTO).
9. Stop the engine, remove the key, and wait for all moving parts to stop before leaving the operating position.
10. Remove the ignition key.
11. Turn the water off and remove the coupling from the washout fitting and hose.
12. Run the mower again for 1 to 3 minutes to remove the excess water.



A broken or missing washout fitting could expose you and others to thrown objects or to blade contact. Contact with the blade or thrown debris contact may cause injury or death.

- **Replace broken or missing washout fitting immediately, before using the mower again.**
- **Plug any holes in the mower with bolts and locknuts.**
- **Never put your hands or feet under the mower or through openings in the mower.**

Storage

1. Disengage the blade control (PTO) and set the parking brake.
2. Stop the engine, remove the key, and wait for all moving parts to stop before leaving the operating position.
3. Remove grass clippings, dirt, and grime from the external parts of the entire tractor, especially the engine. Clean dirt and chaff from the outside of the engine cylinder head fins and blower housing.

Important: You can wash the tractor with a mild detergent and water. Do not use a pressure washer to wash the tractor. Pressure washing may damage the electrical system or wash away necessary grease at friction points. Avoid using water excessively, especially near the control panel, lights, engine, and battery.

4. Check the parking brake; refer to Checking the Parking Brake.
5. Service the air cleaner; refer to Servicing the Air Cleaner.
6. Grease the chassis; refer to Greasing and Lubricating the Tractor.
7. Change the crankcase oil and filter; refer to Servicing the Engine Oil.
8. Check the tire pressure; refer to Checking the Tire Pressure.
9. When storing the tractor for over 30 days, prepare it as follows:
 - A. Add a petroleum based stabilizer/conditioner to fuel in the tank according to the instructions from stabilizer manufacture. Do not use an alcohol based stabilizer (ethanol or methanol).

Note: A fuel stabilizer/conditioner is most effective when mixed with fresh gasoline and used at all times.

- B. Run engine for 5 minutes to distribute conditioned fuel through the fuel system.
- C. Stop the engine, allow it to cool, and drain the fuel tank; refer to Draining the Fuel Tank.
- D. Start the engine and run it until it stops.
- E. Choke or prime the engine.
- F. Start and run the engine until it will not start again.
- G. Recycle the old fuel according to local codes.

Important: Do not store stabilizer/conditioned gasoline over 90 days.

10. Remove and inspect the spark plug; refer to Servicing the Spark Plug. With the spark plug removed from the engine, pour 2 tablespoons of engine oil into the spark plug hole. Use the electric starter to crank the engine and distribute the oil inside the cylinder. Install the spark plug, but do not connect the wire to the spark plug.
11. Disconnect the negative battery cable. Clean the battery and battery terminals. Check the electrolyte level and charge it fully; refer to Servicing the Battery. Leave the negative battery cable disconnected from the battery during storage.

Important: The battery must be fully charged to prevent it from freezing and being damaged at temperatures below 32°F (0°C). A fully charged battery can be stored during the winter without recharging.

12. Check and tighten all bolts, nuts, and screws. Repair or replace any part that is worn or damaged.
13. Paint all scratched or bare metal surfaces with paint available from an Authorized Service Dealer.
14. Store the tractor in a clean, dry garage or storage area. Remove the ignition and KeyChoice keys from the tractor and keep them in a memorable place. Cover the tractor to protect it and keep it clean.

Troubleshooting

| Problem | Possible Cause | Corrective Action |
|---|--|---|
| The starter does not crank. | <ol style="list-style-type: none"> 1. The blade control (PTO) is engaged. 2. The parking brake is not on. 3. The battery is dead. 4. The electrical connections are corroded or loose. 5. A fuse is blown. 6. A relay or switch is damaged. | <ol style="list-style-type: none"> 1. Disengage the blade control (PTO). 2. Set the parking brake. 3. Charge the battery. 4. Check the electrical connections for good contact. 5. Replace the fuse. 6. Contact an Authorized Service Dealer. |
| The engine will not start, starts hard, or fails to keep running. | <ol style="list-style-type: none"> 1. The operator is not seated. 2. The fuel tank is empty. 3. The air cleaner is dirty. 4. The spark plug wire is loose or disconnected. 5. The spark plug is pitted, fouled, or the gap is incorrect. 6. The choke is not closing. 7. There is dirt in the fuel filter. 8. The idle speed is too low or the mixture is incorrect. 9. Dirt, water, or stale fuel is in the fuel system. | <ol style="list-style-type: none"> 1. Sit on the seat. 2. Fill the fuel tank with gasoline. 3. Clean or replace the air cleaner element. 4. Connect the wire to spark plug. 5. Install a new, correctly gapped spark plug. 6. Adjust the throttle cable. 7. Replace the fuel filter. 8. Contact an Authorized Service Dealer. 9. Contact an Authorized Service Dealer. |
| The engine loses power. | <ol style="list-style-type: none"> 1. The engine load is excessive. 2. The air cleaner is dirty. 3. The oil level in the crankcase is low. 4. The cooling fins and air passages under the engine blower housing are plugged. 5. The spark plug is pitted, fouled, or the gap is incorrect. 6. The vent hole in the fuel cap is plugged. 7. There is dirt in fuel filter. 8. Dirt, water, or stale fuel is in the fuel system. | <ol style="list-style-type: none"> 1. Reduce the ground speed. 2. Clean the air cleaner element. 3. Add oil to the crankcase. 4. Remove the obstruction from the cooling fins and air passages. 5. Install a new, correctly gapped spark plug. 6. Clean or replace the fuel cap. 7. Replace the fuel filter. 8. Contact an Authorized Service Dealer. |
| The engine overheats. | <ol style="list-style-type: none"> 1. The engine load is excessive. 2. The oil level in the crankcase is low. 3. The cooling fins and air passages under the engine blower housing are plugged. | <ol style="list-style-type: none"> 1. Reduce the ground speed. 2. Add oil to the crankcase. 3. Remove the obstruction from the cooling fins and air passages. |
| There is an abnormal vibration. | <ol style="list-style-type: none"> 1. The blades are bent or unbalanced. 2. The blade mounting bolt is loose. 3. The engine mounting bolts are loose. 4. There is a loose engine pulley, idler pulley, or blade pulley. 5. The engine pulley is damaged. | <ol style="list-style-type: none"> 1. Install new blades. 2. Tighten the blade mounting bolt. 3. Tighten the engine mounting bolts. 4. Tighten the appropriate pulley. 5. Contact an Authorized Service Dealer. |
| The blades do not rotate. | <ol style="list-style-type: none"> 1. The blade drive belt is worn, loose, or broken. 2. The blade drive belt is off of the pulley. | <ol style="list-style-type: none"> 1. Install a new blade drive belt. 2. Install the blade drive belt and check the idler pulley and belt guides for the correct position. |

| Problem | Possible Cause | Corrective Action |
|--------------------------------|--|--|
| The tractor does not drive. | <ol style="list-style-type: none"> 1. The drive control is in the Push position. 2. The traction belt is worn, loose, or broken. 3. The traction belt is off of the pulley. | <ol style="list-style-type: none"> 1. Move the drive control to the Operate position. 2. Contact an Authorized Service Dealer. 3. Contact an Authorized Service Dealer. |
| The mower is cutting unevenly. | <ol style="list-style-type: none"> 1. The tire pressure is incorrect. 2. The mower is not level. 3. The underside of the mower is dirty. | <ol style="list-style-type: none"> 1. Set the tire pressure. 2. Level the mower from side-to-side and front-to-rear. 3. Clean the underside of the mower. |

Schematics

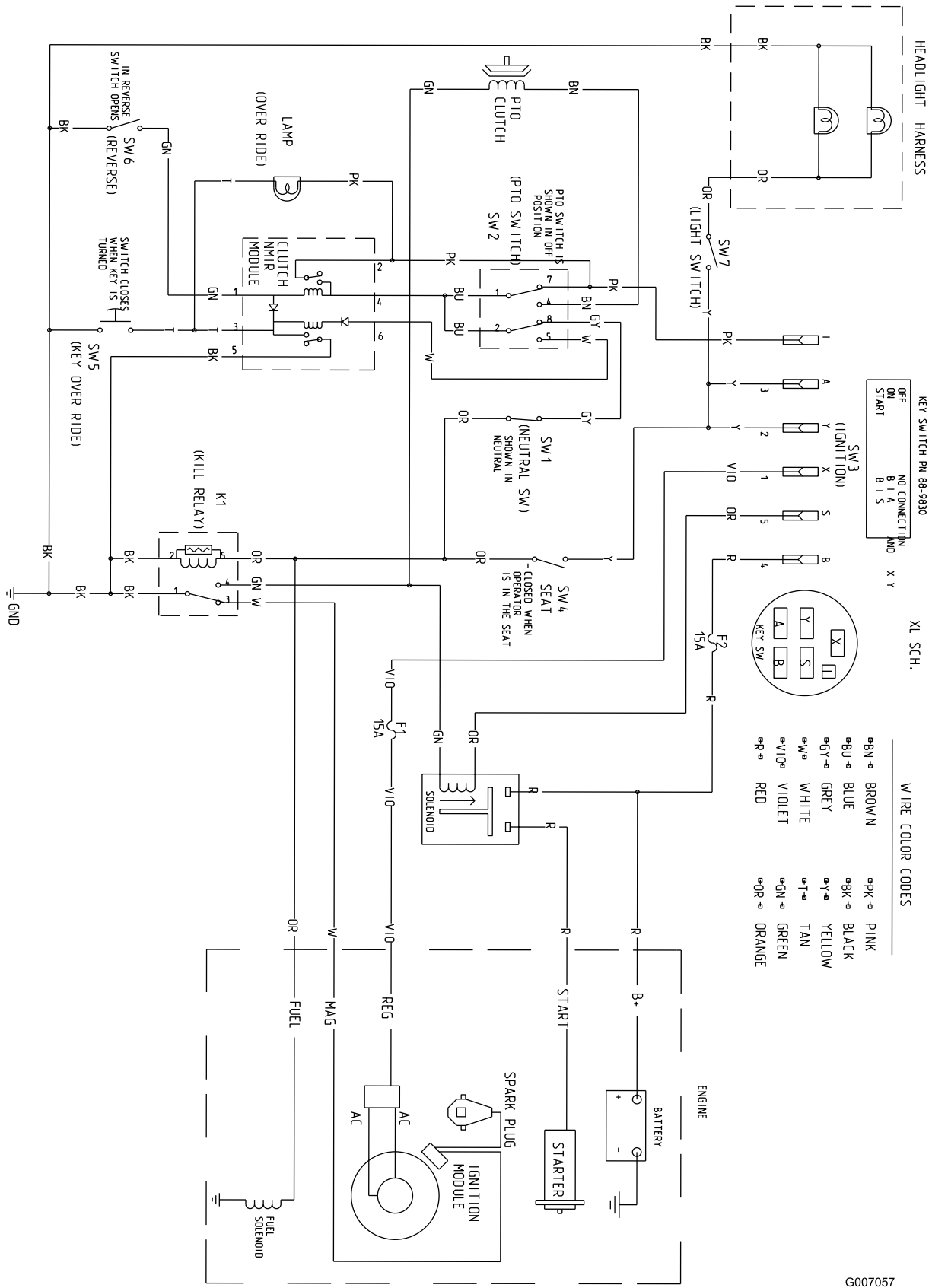

Wiring Diagram (Rev. A)

G007057

Notes:

Notes:

International Distributor List

| Distributor: | Country: | Phone Number: |
|-------------------------------------|----------------------|----------------------|
| Atlantis Su ve Sulama Sistemleri Lt | Turkey | 90 216 344 86 74 |
| Balama Prima Engineering Equip | Hong Kong | 852 2155 2163 |
| B-Ray Corporation | Korea | 82 32 551 2076 |
| Casco Sales Company | Puerto Rico | 787 788 8383 |
| Ceres S.A | Costa Rica | 506 239 1138 |
| CSSC Turf Equipment (pvt) Ltd | Sri Lanka | 94 11 2746100 |
| Cyril Johnston & Co | Northern Ireland | 44 2890 813 121 |
| Equivier | Mexico | 52 55 539 95444 |
| Femco S.A. | Guatemala | 502 442 3277 |
| G.Y.K. Company ltd. | Japan | 81 726 325 861 |
| Geomechaniki of Athens | Greece | 30 10 935 0054 |
| Guandong Golden Star | China | 86 20 876 51338 |
| Hako Ground and Garden | Sweden | 46 35 10 0000 |
| Hako Ground and Garden | Norway | 47 22 90 7760 |
| Hayter Limited (U.K.) | United Kingdom | 44 1279 723 444 |
| Hydroturf Int. Co Dubai | United Arab Emirates | 97 14 347 9479 |
| Hydroturf Egypt LLC | Egypt | 202 519 4308 |
| Ibea S.p.A. | Italy | 39 0331 853611 |
| Irriamc | Portugal | 351 21 238 8260 |
| Irrigation Products Int'l Pvt Ltd | India | 86 22 83960789 |
| Jean Heybroek b.v. | Netherlands | 31 30 639 4611 |
| Lely (U.K.) Limited | United Kingdom | 44 1480 226 800 |
| Maquiver S.A. | Colombia | 57 1 236 4079 |
| Maruyama Mfg. Co. Inc. | Japan | 81 3 3252 2285 |
| Metra Kft | Hungary | 36 1 326 3880 |
| Mountfield a.s. | Czech Republic | 420 255 704 220 |
| Munditol S.A. | Argentina | 54 11 4 821 9999 |
| Oslinger Turf Equipment SA | Ecuador | 593 4 239 6970 |
| Oy Hako Ground and Garden Ab | Finland | 358 987 00733 |
| Parkland Products Ltd | New Zealand | 64 3 34 93760 |
| Prochaska & Cie | Austria | 43 1 278 5100 |
| RT Cohen 2004 Ltd | Israel | 972 986 17979 |
| Riversa | Spain | 34 9 52 83 7500 |
| Roth Motorgerate GmBh & Co | Germany | 49 7144 2050 |
| Sc Svend Carlsen A/S | Denmark | 45 66 109 200 |
| Solvvert S.A.S | France | 33 1 30 81 77 00 |
| Spypros Stavrinides Limited | Cyprus | 357 22 434131 |
| Surge Systems India Limited | India | 91 1 292299901 |
| T-Markt Logistics Ltd | Hungary | 36 26 525 500 |
| Toro Australia | Australia | 61 3 9580 7355 |
| Toro Europe BVBA | Belgium | 32 14 562 960 |



The Toro Warranty

Conditions and Products Covered

The Toro® Company and its affiliate, Toro Warranty Company, pursuant to an agreement between them, jointly promises to the original purchaser* to repair any Toro Product used for normal residential purposes* if defective in materials or workmanship. The following time periods apply from the date of original purchase:

| Products | Warranty Period |
|-----------------------------|-------------------------|
| Walk Power Mowers | 2-year limited warranty |
| Rear Engine Riders | 2-year limited warranty |
| Lawn & Garden Tractors | 2-year limited warranty |
| Electric Hand Held Products | 2-year limited warranty |
| Snowthrowers | 2-year limited warranty |
| Consumer Zero Turn | 2-year limited warranty |

* "Original purchaser" means use the person who originally purchased Toro products.

* "Normal residential purposes" means use of the product on the same lot as your home. Use at more than one location is considered commercial use, and the commercial use warranty would apply.

Limited Warranty for Commercial Use

Toro Consumer Products and attachments used for commercial, institutional, or rental use are warranted against defects in materials or workmanship for the following time periods from the date of original purchase:

| Products | Warranty Period |
|-----------------------------|-----------------|
| Walk Power Mowers | 90 day warranty |
| Rear Engine Riders | 90 day warranty |
| Lawn & Garden Tractors | 90 day warranty |
| Electric Hand Held Products | 90 day warranty |
| Snowthrowers | 90 day warranty |
| Consumer Zero Turn | 45 day warranty |

Instructions for Obtaining Warranty Service

If you think that your Toro Product contains a defect in materials or workmanship, follow this procedure:

1. Contact your seller to arrange service of the product. If for any reason it is impossible for you to contact your seller, you may contact any Toro Authorized Distributor to arrange service.
2. Bring the product and your proof of purchase (sales receipt) to your seller or the Service Dealer.

If for any reason you are dissatisfied with the Service Dealer's analysis or with the assistance provided, contact the Toro importer or contact us at:

Customer Care Department, Consumer Division
Toro Warranty Company
8111 Lyndale Avenue South
Bloomington, MN 55420-1196
Manager: Technical Product Support: 001-952-887-8248

See attached Distributor List

Owner Responsibilities

You must maintain your Toro Product by following the maintenance procedures described in the operator's manual. Such routine maintenance, whether performed by a dealer or by you, is at your expense.

Items and Conditions Not Covered

This express warranty does not cover:

- Cost of regular maintenance service or parts, such as filters, fuel, lubricants, tune-up parts, blade sharpening, brake and clutch adjustments.
- Any product or part which has been altered or misused or required replacement or repair due to normal wear, accidents, or lack of proper maintenance.
- Repairs necessary due to improper fuel, contaminants in the fuel system, or failure to properly prepare the fuel system prior to any period of non-use over three months.
- Engine and transmission. These are covered by the appropriate manufacturer's guarantees with separate terms and conditions.

All repairs covered by this warranty must be performed by an Authorized Toro Service Dealer using Toro approved replacement parts.

General Conditions

The purchaser is covered by the national laws of each country. The rights to which the purchaser is entitled with the support of these laws are not restricted by this warranty.