



Count on it.

Parts Catalog

**Z Master® G3 Riding Mower
with 60in TURBO FORCE® Side Discharge
Mower**

Model No. 74935—Serial No. 310000001 and Up

Ordering Replacement Parts

To order replacement parts, please supply the part number, the quantity, and the description of each part desired.

Understanding Reference Numbers

Each identified part in an illustration has a reference number. The reference number for a part also appears in the parts list, along with other information about the part.

This catalog uses two special reference number formats, one to indicate parts in a service assembly and another to indicate the quantity of a given part in an illustration.

Service Assembly Reference Numbers

Parts in service assemblies have reference numbers in the form a:b. The a represents the reference number of the entire service assembly and the b represents a sequential number unique to each part within the service assembly.

For example, a wheel assembly might be identified by reference number 6, the tire by 6:1, the valve by 6:2, and the wheel by 6:3. When you order the assembly identified by reference number 6, you receive all parts identified by reference numbers 6:1, 6:2, and 6:3. However, you may also order any part individually. Reference numbers of this type appear in illustration and in parts lists.

Reference Numbers Indicating Quantity

In an illustration, if a reference number indicates more than one part, the reference number has the form nX y. The n represents the quantity of the part, the X is the multiplication symbol, and the y represents the reference number.

For example, in an illustration, the reference number 2X 37 means that two of the parts identified by reference number 37 are indicated.

List of Abbreviations

AR: as required
ASM: assembly
BBC: blade brake clutch
CARR: carriage
CCW: counter clock wise
CW: clockwise
DEG: degrees
ECM: electronic control module
EXT: external
FH: flat head
GA: gauge
HD: heavy-duty
HF: hex flange
HH: hex head
HHF: hex head flange
HHFTF: hex head flange thread forming
HJ: hex jam
HLH: hex lag head
HOC: height-of-cut

HSBH: hex socket button head
HSFH: hex socket flat head
HSH: hex socket head
HWH: hex washer head
HWHTF: hex washer head thread forming
HYD: hydraulic
LH: left hand
NI: nylon insert
NPTF: national pipe thread fine
PFH: phillips flat head
PPH: phillips pan head
PPHTF: phillips pan head thread forming
PRH: phillips round head
PTH: phillips truss head
PTO: power-take-off
RH: right hand
ROPS: roll-over protection system
RRB: rear roller brush

SFH: slotted fillister head
SHH: slotted hex head
SHWH: slotted hex washer head
SPH: slotted pan head
SQH: square head
SRH: slotted round head
STD: standard
TAP: self tapping
TTH: torx truss head

Contents

Front Frame and Caster Wheel Assembly	4
Roll-Over Protection System Assembly No. 116-0231	5
Caster Wheel and Fork Assembly	6
Hydro Mounting and Belt Assembly	7
Pump Idler Assembly No. 116-1255	8
LH Hydro Assembly No. 116-1382	9
LH Hydro Assembly No. 116-1382	10
Rear Wheel and Park Brake Assembly	11
Brake Handle Assembly No. 116-1878	12
Fuel System Assembly	13
Fuel Tank Assembly No. 109-9357	14
Seat Mounting Assembly	15
Seat Assembly No. 116-0035	16
Motion Control Assembly	17
Fender, Console and Control Assembly	18
LH Console Assembly No. 115-7401	19
RH Console Assembly No. 115-7400	20
Electrical System Assembly	21
Deck Lift Assembly	22
Height-of-Cut Assembly No. 109-7438	23
Engine, Clutch and Muffler Assembly	24
Deck Assembly	25
Deck Decal Assembly No. 112-4180	27
Idler Assembly	28
Spindle Assembly No. 117-6159	29
Rubber Deflector Assembly No. 108-2792	30
Lever Assembly No. 107-1664	31
Attachments and Accessories	32

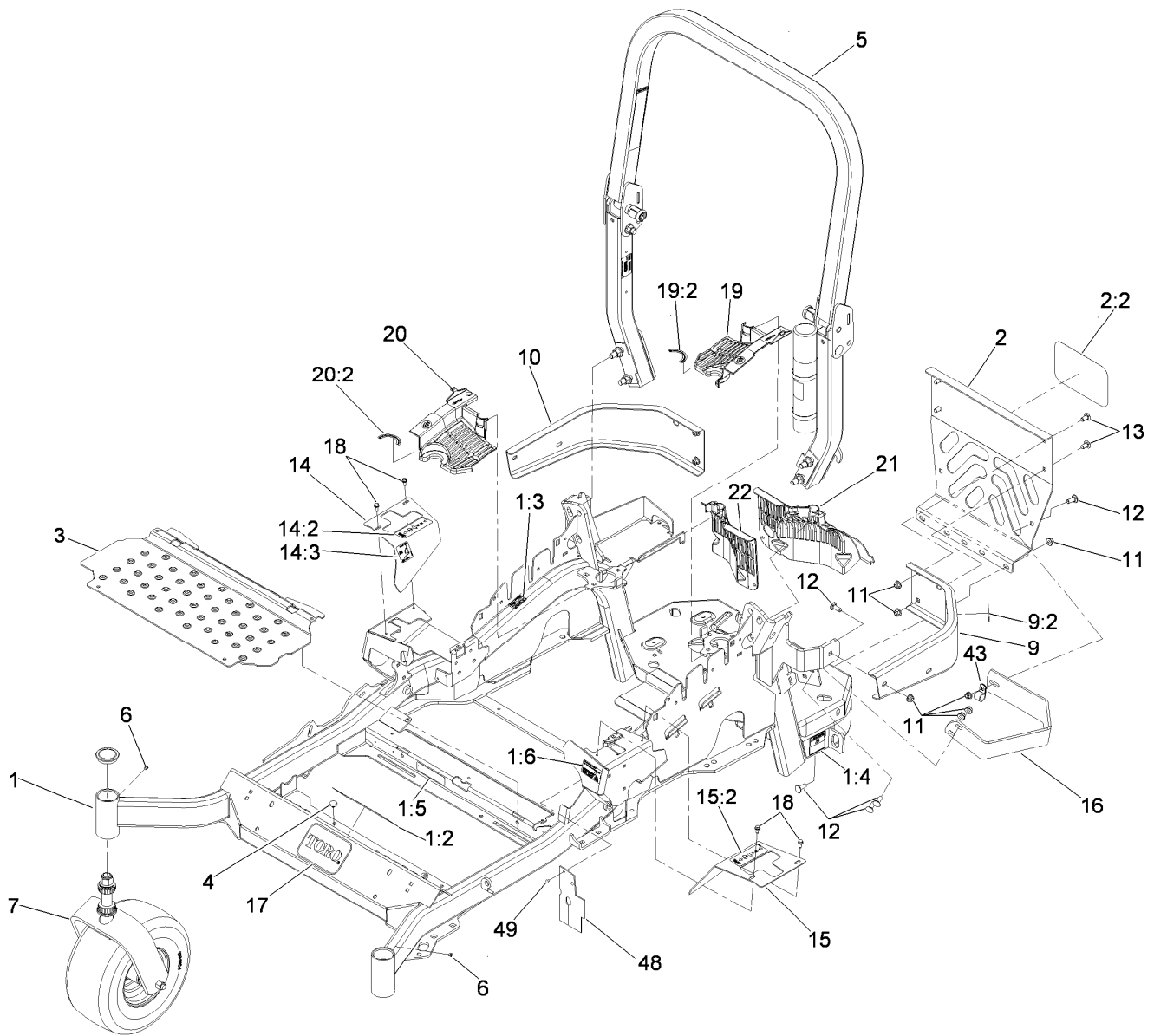

Front Frame and Caster Wheel Assembly

Ref.	Part Number	Qty.	Description	Ref.	Part Number	Qty.	Description
1	116-2126	1	Main Frane ASM	14	116-0579	1	RH Motion Control Cover ASM
1:2	107-2112	1	Decal-Warning	14:2	109-7232	1	Decal-Motion Control
1:3	103-2076	2	Decal-Caution	14:3	109-7929	1	Decal-Park Brake
1:4	116-0205	2	Decal-Belt Drive	15	116-0580	1	LH Motion Control Cover ASM
1:5	117-2718	1	Decal-Arrester, Spark	15:2	109-7232	1	Decal-Motion Control
1:6	116-1654	1	Decal Fuel Fill	16	116-0043-03	1	Guard-Muffler
2	115-7410	1	Rear Guard ASM	17	68-3640	1	Decal
2:2	67-7320	1	Decal	18	32144-10	4	Screw-HWH
3	116-0024-01	1	Floorpan	19	116-0170	1	LH Hydro Guard ASM
4	1-513658	2	Bumper	19:2	116-0157	1	Decal-Hydro Oil
5	116-0231	1	ROPS ASM	20	116-0171	1	RH Hydro Guard ASM
6	1-811010	2	Plug	20:2	116-0157	1	Decal-Hydro Oil
7		2	Caster Wheel ASM ●	21	109-9057	1	Guard-Hydro, Rear LH
9	116-0180	1	LH Bumper ASM	22	109-9058	1	Guard-Hydro, Rear RH
9:2	103-2076	1	Decal-Caution	43	1-633396	1	Clip-Loom
10	116-0057-03	1	Bumper-RH	48	116-2362	1	Deflector, Air Flow
11	104-8301	11	Nut-Flange, NI	49	1-803035	2	Rivet-Pop
12	3231-22	7	Screw-CARR				
13	3231-21	4	Screw-CARR				

● Not serviced separately

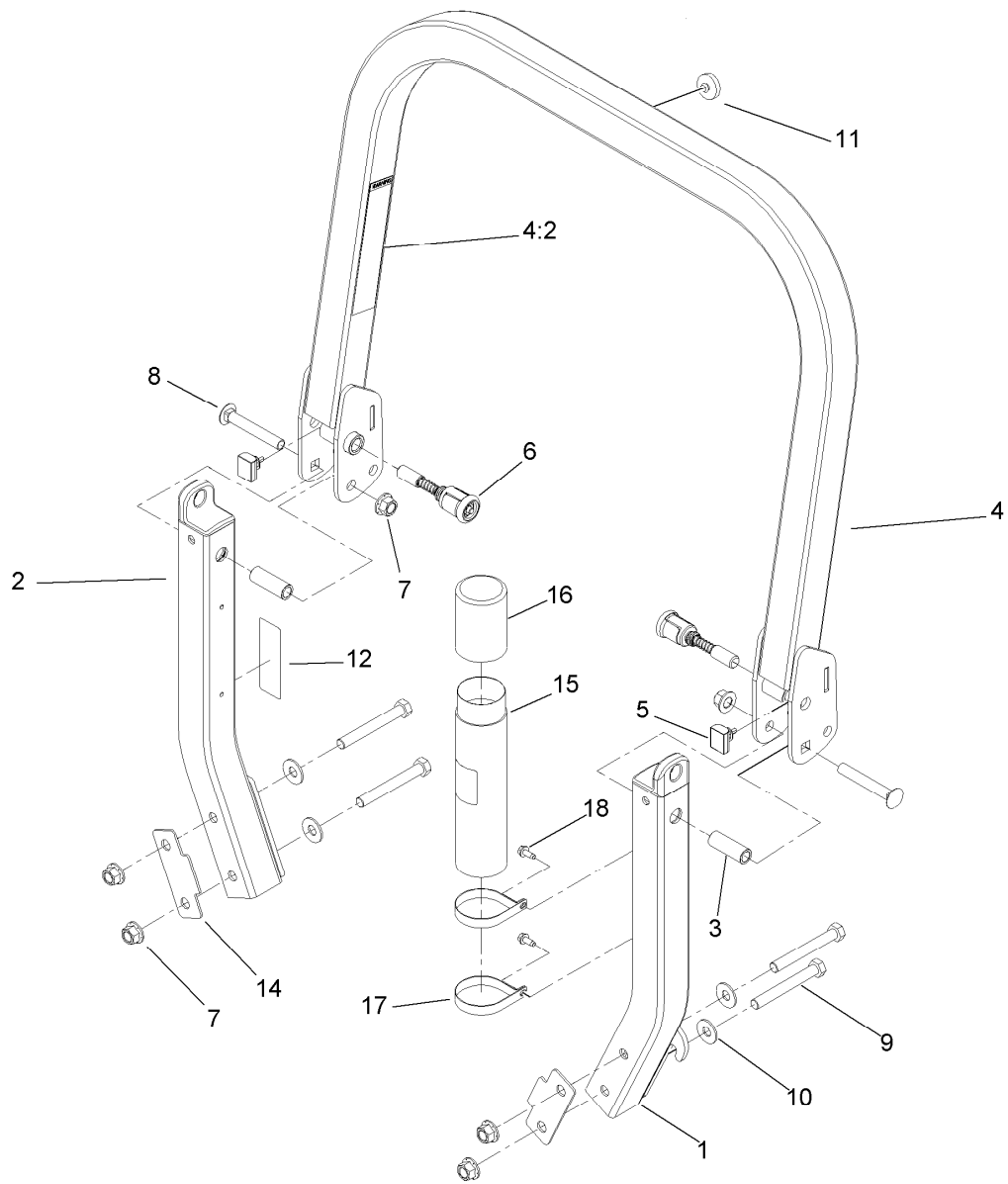

Roll-Over Protection System Assembly No. 116-0231

Ref.	Part Number	Qty.	Description	Ref.	Part Number	Qty.	Description
1		1	Leg-ROPS, LH ●	9	325-17	4	Screw-HH
2		1	Leg-ROPS, RH ●	10	109-9505	4	Washer-Spring
3	109-6653	2	Spacer	11	109-9233	1	Bumper-Push-In, Rubber
4		1	Upper ROPS ASM ●	12	116-0090	1	Decal-Caution
4:2	107-2102	1	Decal-Warning, Folding ROPS	14	116-0960	2	Spacer
5	109-5337	2	Bumper-ROPS	15	104-7050	1	Tube-Manual
6	116-0104	2	Spring Pin ASM	16	104-7048	1	Cap-Housing
7	99-5107	6	Nut-Lock	17	107-1865	2	R-Clamp
8	3233-10	2	Screw-CARR	18	32144-10	2	Screw-HWH

● Not serviced separately

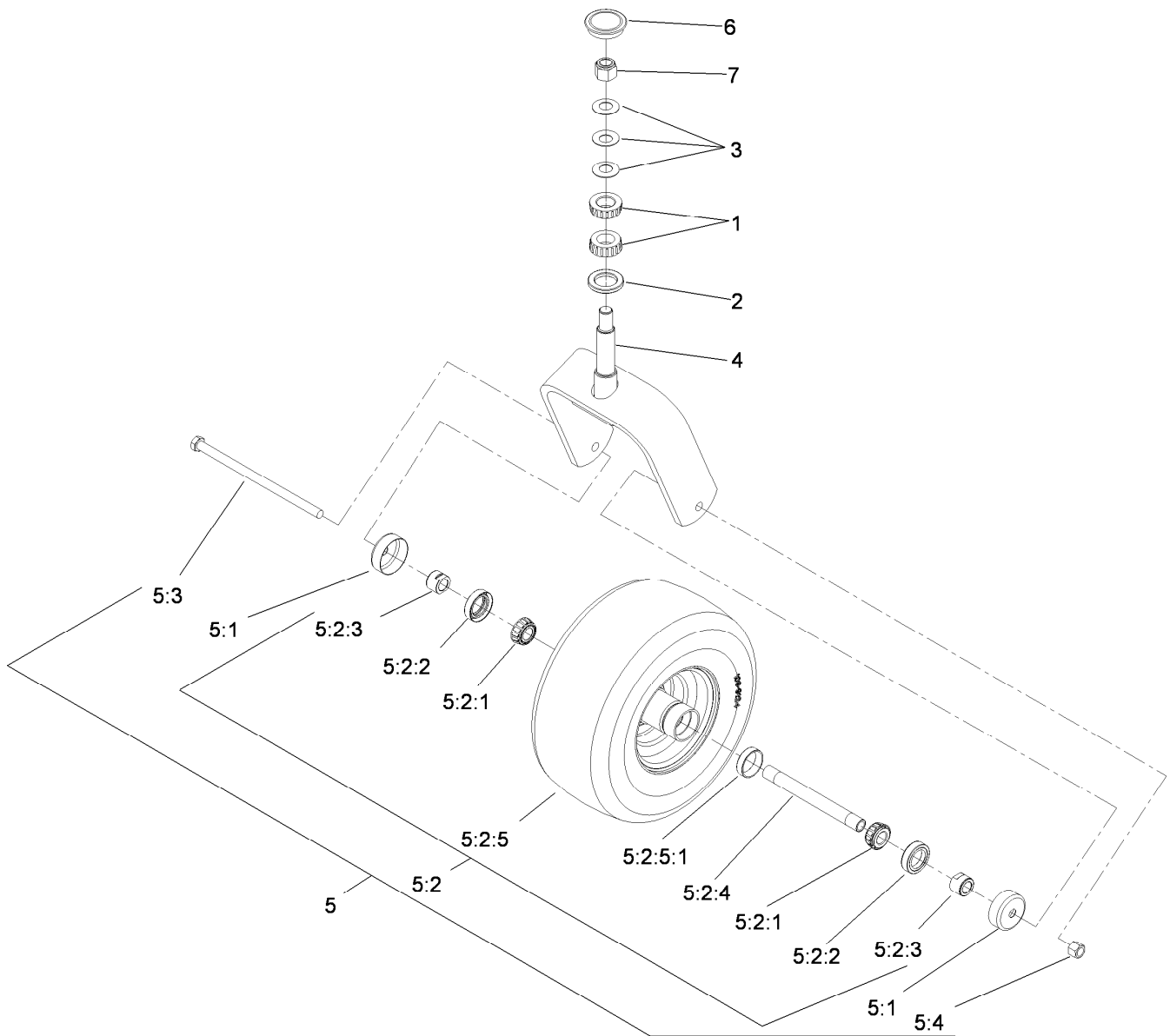

Caster Wheel and Fork Assembly

<i>Ref.</i>	<i>Part Number</i>	<i>Qty.</i>	<i>Description</i>
1	1-543509	2	Bearing-Roller, Tapered
2	1-543511	1	Seal-Grease
3	1-633508	3	Washer-Bellville
4	103-1474-01	1	Caster-Fork
5	109-9127	1	Wheel And Tire ASM
5:1	103-2768	2	Guard-Seal
5:2		1	Wheel And Tire ASM ●
5:2:1	1-633585	2	Bearing-Cone, Taper
5:2:2	103-0063	2	Seal-Caster

<i>Ref.</i>	<i>Part Number</i>	<i>Qty.</i>	<i>Description</i>
5:2:3	103-3051	2	Spacer-Nut
5:2:4	103-5156	1	Axle-Caster
5:2:5	109-9124	1	Wheel And Tire ASM
5:2:5:1	1-633584	1	Bearing-Cup
5:3	325-39	1	Screw-HH
5:4	3296-23	1	Nut-Lock, NI
6	103-4882	1	Cap-Grease
7	3296-51	1	Nut-Lock, NI

● Not serviced separately

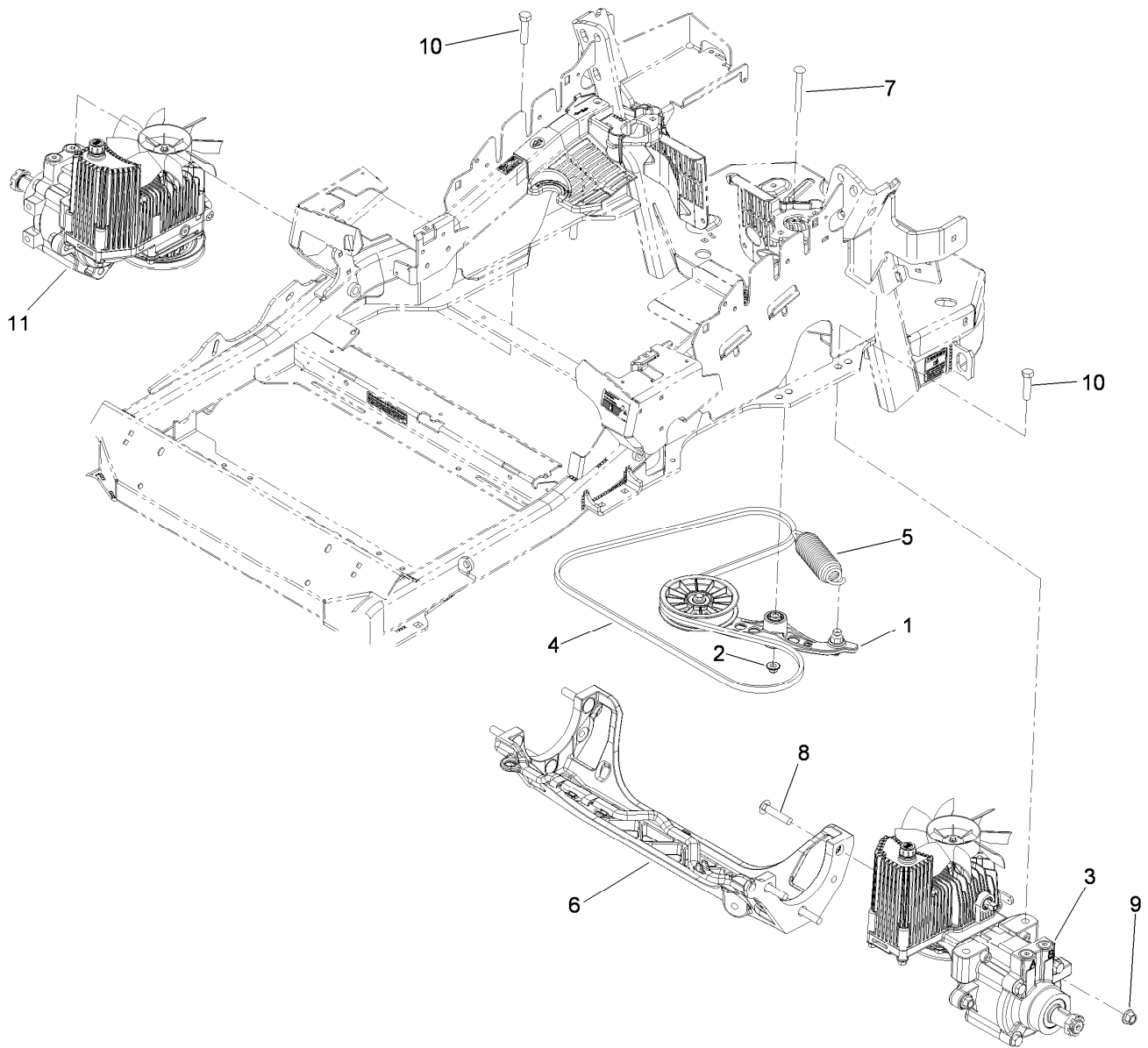

Hydro Mounting and Belt Assembly

Ref.	Part Number	Qty.	Description
1	116-1255	1	Pump Idler ASM
2	109-6658	1	Nut-Flange, NI (Split)
3	116-1382	1	LH Hydro ASM (16Cc W/Shock)
4	109-3388	1	Belt
5	116-0133	1	Extension-Spring
6	109-9375	1	Cradle-Hydro, Machined
7	3231-41	1	Bolt-Carriage
8	3233-34	6	Screw-CARR
9	99-5107	6	Nut-Lock
10	325-8	4	Screw-HH
11	116-1383	1	RH Hydro ASM (16Cc W/Shock)
99	114-4713	1	Hypr-Oil 500 (Quart) ●
99	114-4714	1	Hypr-Oil 500 (Gallon) ●
99	114-4715	1	Hypr-Oil 500-5 (5 Gallon) ●
99	117-0390	1	Filter-Hydro ●

● Not illustrated



Pump Idler Assembly No. 116-1255

Ref.	Part Number	Qty.	Description
1		1	Arm-Pump, Idler ●
2	43-0940	1	Spacer-Hub, Blower
3	103-3504	2	Bearing-Spherical
4	103-3505	1	Seal-Double Lip
5	103-3506	1	Seal-Single Lip
6	109-6658	1	Nut-Flange, NI (Split)
7	106-7159	2	O-Ring
8	323-8	1	Screw-HH
9	32120-10	2	Ring-Snap
10	302-19	1	Fitting-Grease
11	109-8076	1	Pulley-Idler
12	109-7399	1	Pin-Anchor, Spring

● Not serviced separately

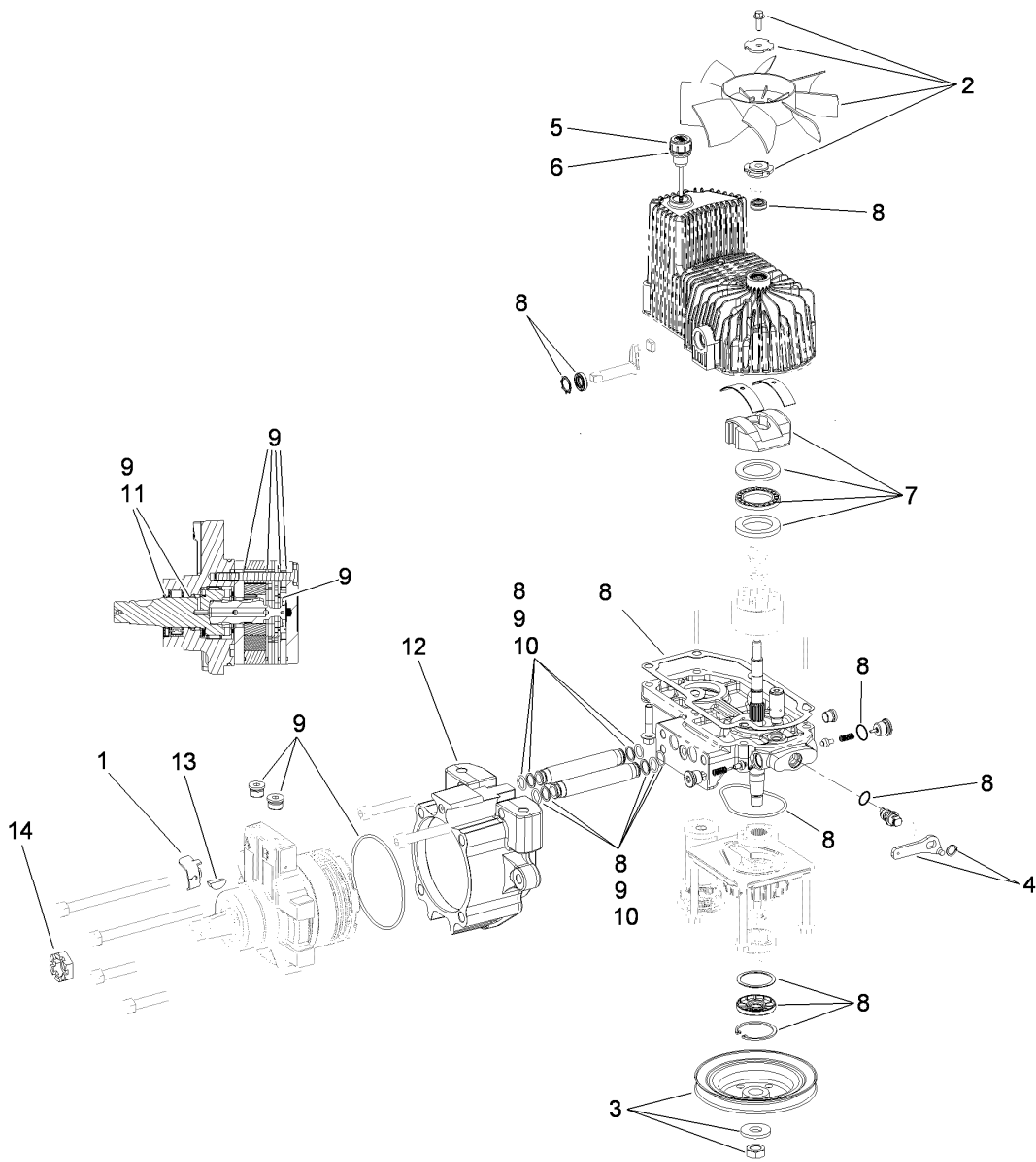

LH Hydro Assembly No. 116-1382

Ref.	Part Number	Qty.	Description
1	116-1758	1	Bracket-Anchor, Cable
2	116-0233	1	Fan Kit
3	116-0234	1	Pulley Kit
4	116-0235	1	Handle-Bypass Valve, Hydro
5	116-0236	1	Dipstick-Hydro W/Gasket
6	116-0237	1	Gasket-Dipstick, Hydro
7	116-1367	1	Swash Block Kit
8	116-1368	1	Pump Seal Kit
9	116-1369	1	Motor Seal Kit
10	116-1370	1	Tube Seal Kit
11	116-1371	1	Output Shaft Seal Kit
12	116-1372	1	Cup-Nose
13	3257-42	1	Key-Woodruff
14	1-809036	1	Nut-HH
99	116-1373	1	Flow Test Kit ●

● Not illustrated

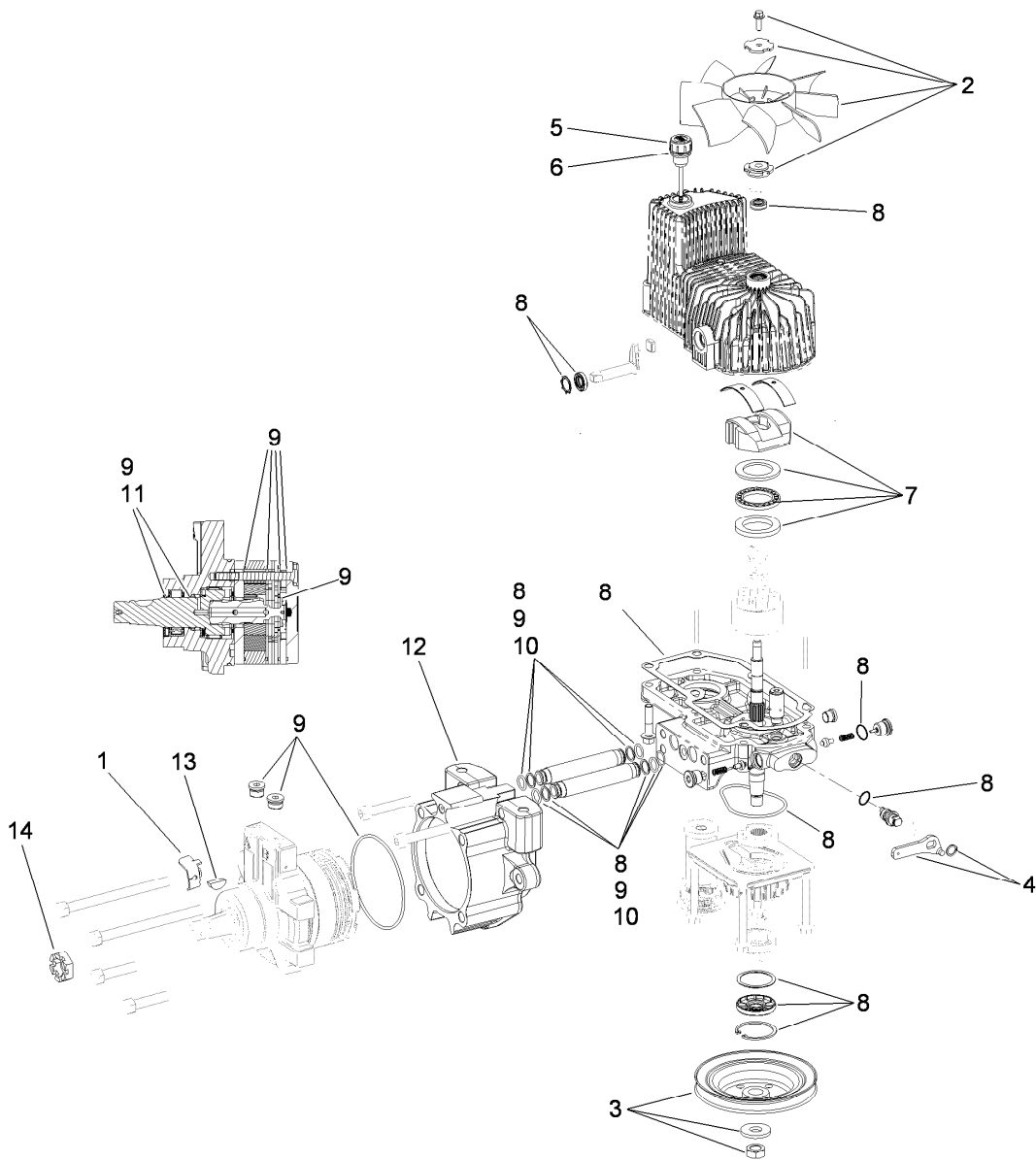

LH Hydro Assembly No. 116-1382

Ref.	Part Number	Qty.	Description
1	116-1758	1	Bracket-Anchor, Cable
2	116-0233	1	Fan Kit
3	116-0234	1	Pulley Kit
4	116-0235	1	Handle-Bypass Valve, Hydro
5	116-0236	1	Dipstick-Hydro W/Gasket
6	116-0237	1	Gasket-Dipstick, Hydro
7	116-1367	1	Swash Block Kit
8	116-1368	1	Pump Seal Kit
9	116-1369	1	Motor Seal Kit
10	116-1370	1	Tube Seal Kit
11	116-1371	1	Output Shaft Seal Kit
12	116-1372	1	Cup-Nose
13	3257-42	1	Key-Woodruff
14	1-809036	1	Nut-HH
99	116-1373	1	Flow Test Kit ●

● Not illustrated

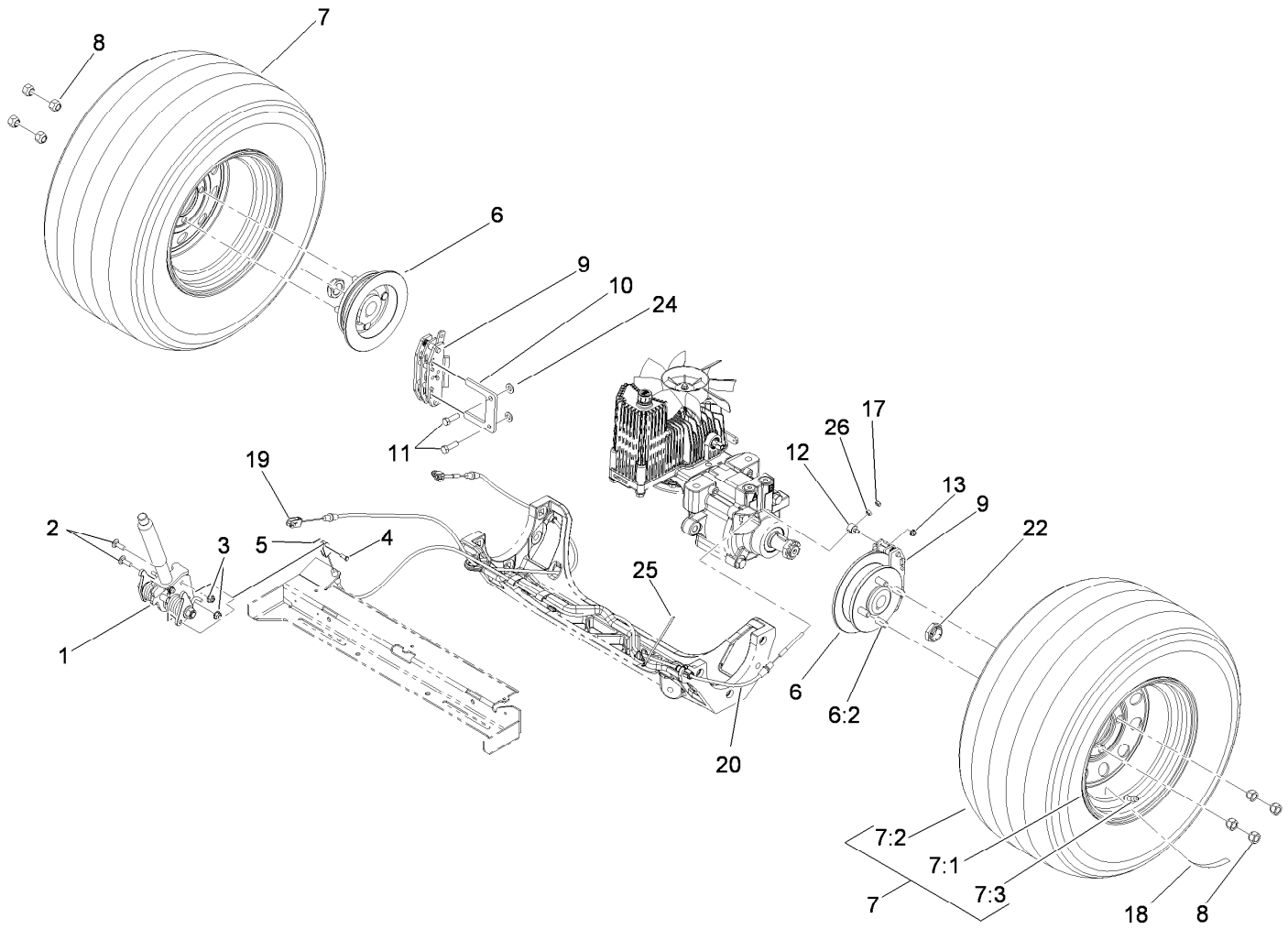

Rear Wheel and Park Brake Assembly

Ref.	Part Number	Qty.	Description	Ref.	Part Number	Qty.	Description
1	116-1878	1	Brake Handle ASM	10	109-0958	2	Plate-Mount, Brake
2	3230-2	2	Bolt-CARR	11	92-5727	4	Screw-Lock, Patch
3	104-8300	2	Nut-Flange, NI	12	112-8379	2	Swivel
4	60-1730	2	Pin-Clevis	13	104-7201	2	Nut-HF
5	3272-1	2	Pin-Cotter	17	3296-13	2	Nut-Lock NI
6	117-6163	2	Wheel Hub And Stud ASM	18	116-0165	2	Decal-Hub, Wheel
6:2	1-633926	4	Stud-Wheel	19	115-3584	1	Cable
7	109-3248	2	Wheel And Tire ASM	20	115-3585	1	Cable
7:1	109-2871	1	Rim ASM	22	1-809036	2	Nut-HH
7:2	103-2744	1	Tire	24	3256-24	4	Washer-Flat
7:3	232-27	1	Stem-Valve	25	116-0940	1	Tie-Cable
8	242-50	8	Nut-Lug	26	3219-1	2	Nut-Hex
9	109-2889	2	Caliper-Brake				



Brake Handle Assembly No. 116-1878

<i>Ref.</i>	<i>Part Number</i>	<i>Qty.</i>	<i>Description</i>	<i>Ref.</i>	<i>Part Number</i>	<i>Qty.</i>	<i>Description</i>
1	99-5107	1	Nut-Lock	10	115-3581	1	Rod-Release, Brake
2	117-0380	1	Spacer	11	115-3592	1	Grip
3	115-3580	1	Arm-Brake, LH	12	112-8387	1	Bolt-Shoulder
4	117-0376	1	Spring-Torsion, RH	13	117-0375	1	Spring-Torsion, LH
5	115-3574	1	Plate-Latch	14	115-3579	1	Arm-Brake, RH
6	104-7201	1	Nut-HF	15	117-0379	1	Bolt-Shoulder
7	116-1876-03	1	Brake Handle ASM	16	3256-26	1	Washer-Flat
8	114-1207	1	Washer-Special	17	115-2750	1	Knob
9	114-8187	1	Spring-Compression				

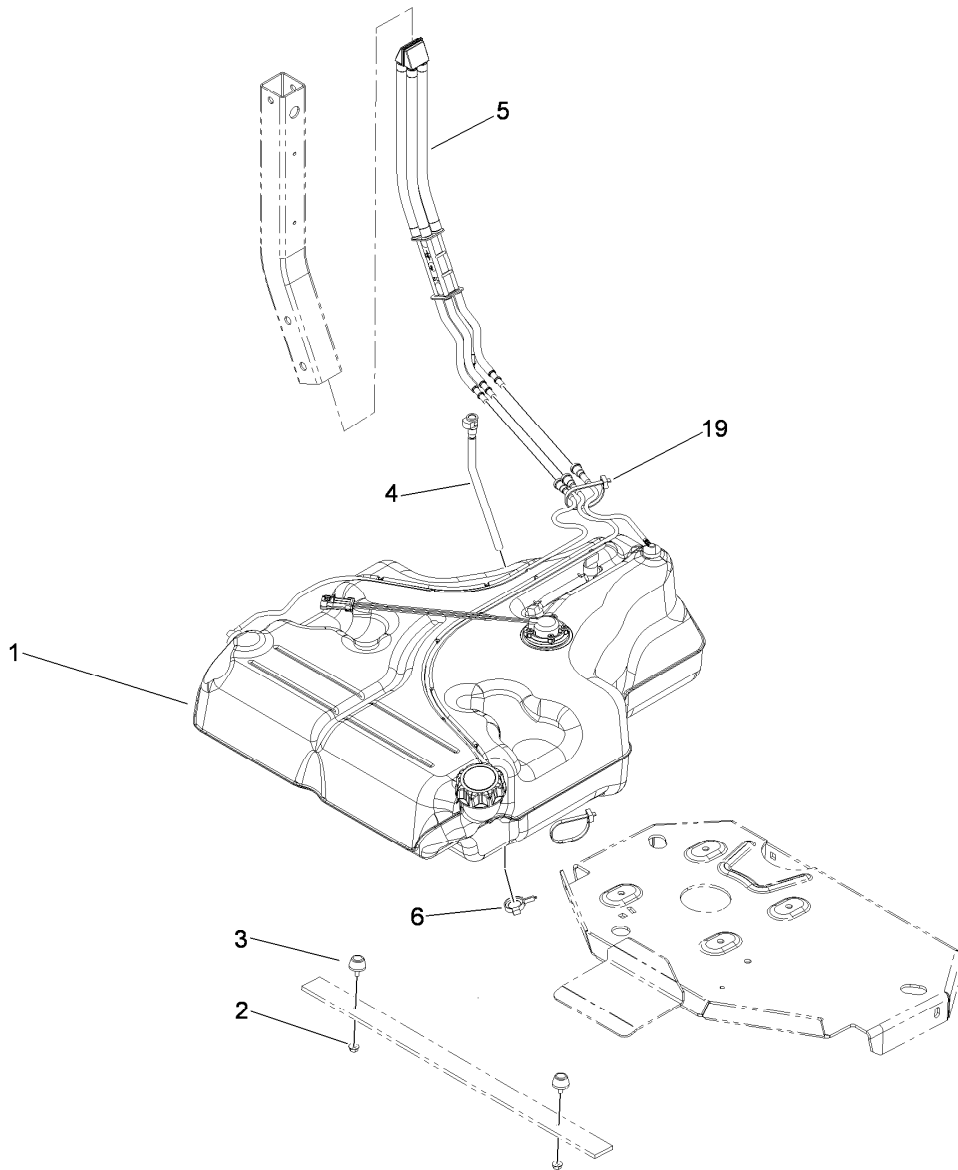

Fuel System Assembly

<i>Ref.</i>	<i>Part Number</i>	<i>Qty.</i>	<i>Description</i>
1	109-9357	1	Fuel Tank ASM
2	32128-33	2	Nut-HF
3	109-2365	2	Bumper-Rubber (W/Stud)
4	109-9450	1	Tube-Vent, Fuel Drain
5	109-9491	1	Fuel Manifold Vent ASM
6	105-1853	1	Clamp-Hose
19	1-303335	1	Tie-Plastic

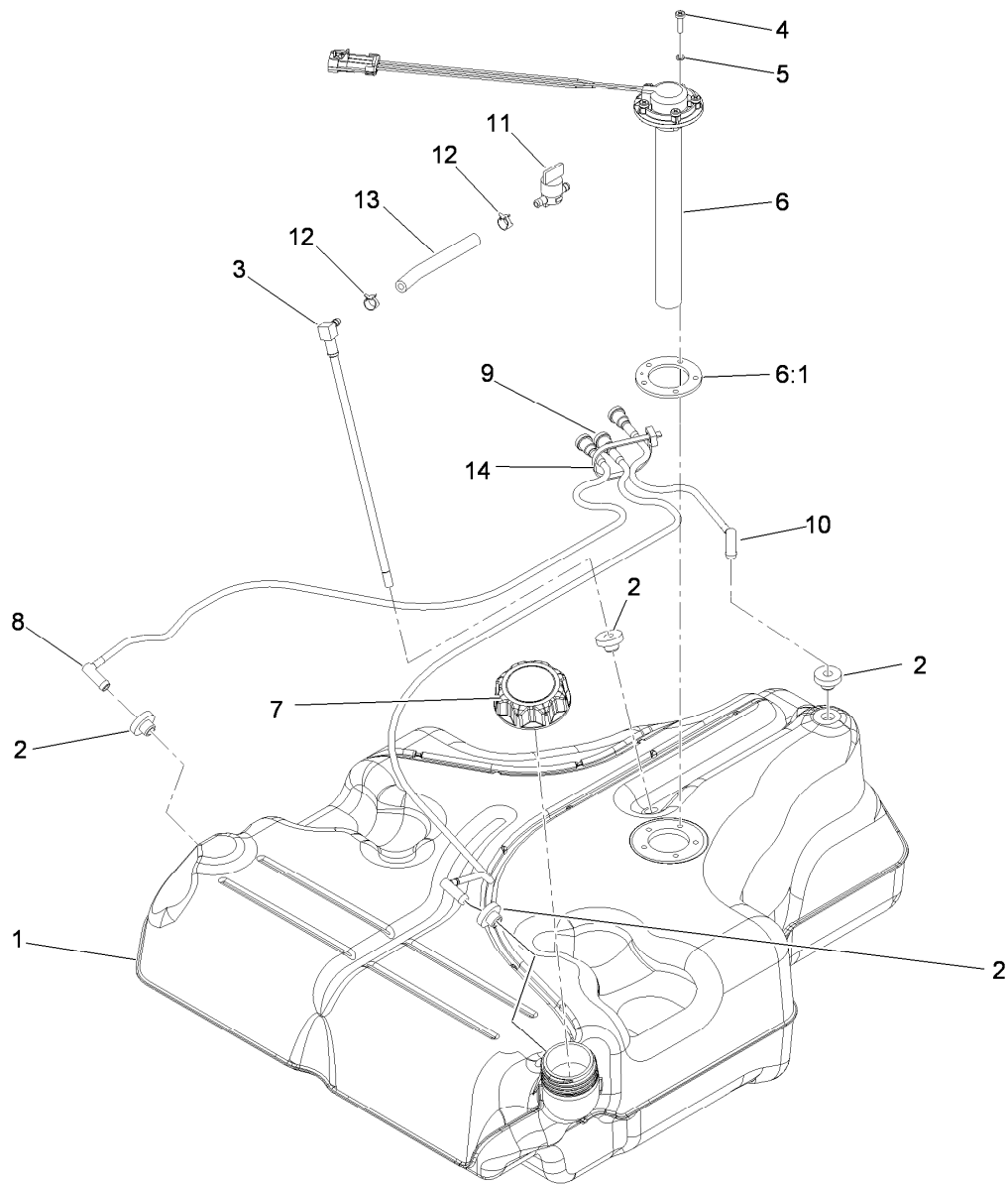

Fuel Tank Assembly No. 109-9357

Ref.	Part Number	Qty.	Description
1		1	Tank-Fuel, Belly ●
2	46-6560	4	Bushing
3	116-2459	1	Fuel Line Kit (With Grommet)
4	9107944	5	Screw-Pan
5	3253-17	5	Washer-Lock
6	116-0003	1	Sender-Fuel Level
6:1	109-9620	1	Gasket-Sender, Fuel
7	109-9619	1	Cap-Fuel
8	116-2460	1	RH Vent Line Kit (With Grommet)
9	116-2461	1	LH Vent Line Kit (With Grommet)
10	116-2462	1	Rear Vent Line Kit (With Grommet)
11	1-603770	1	Valve-Fuel
12	2412-98	2	Clamp
13	109-0650	1	Hose-Fuel
14	1-303335	1	Tie-Plastic

● Not serviced separately

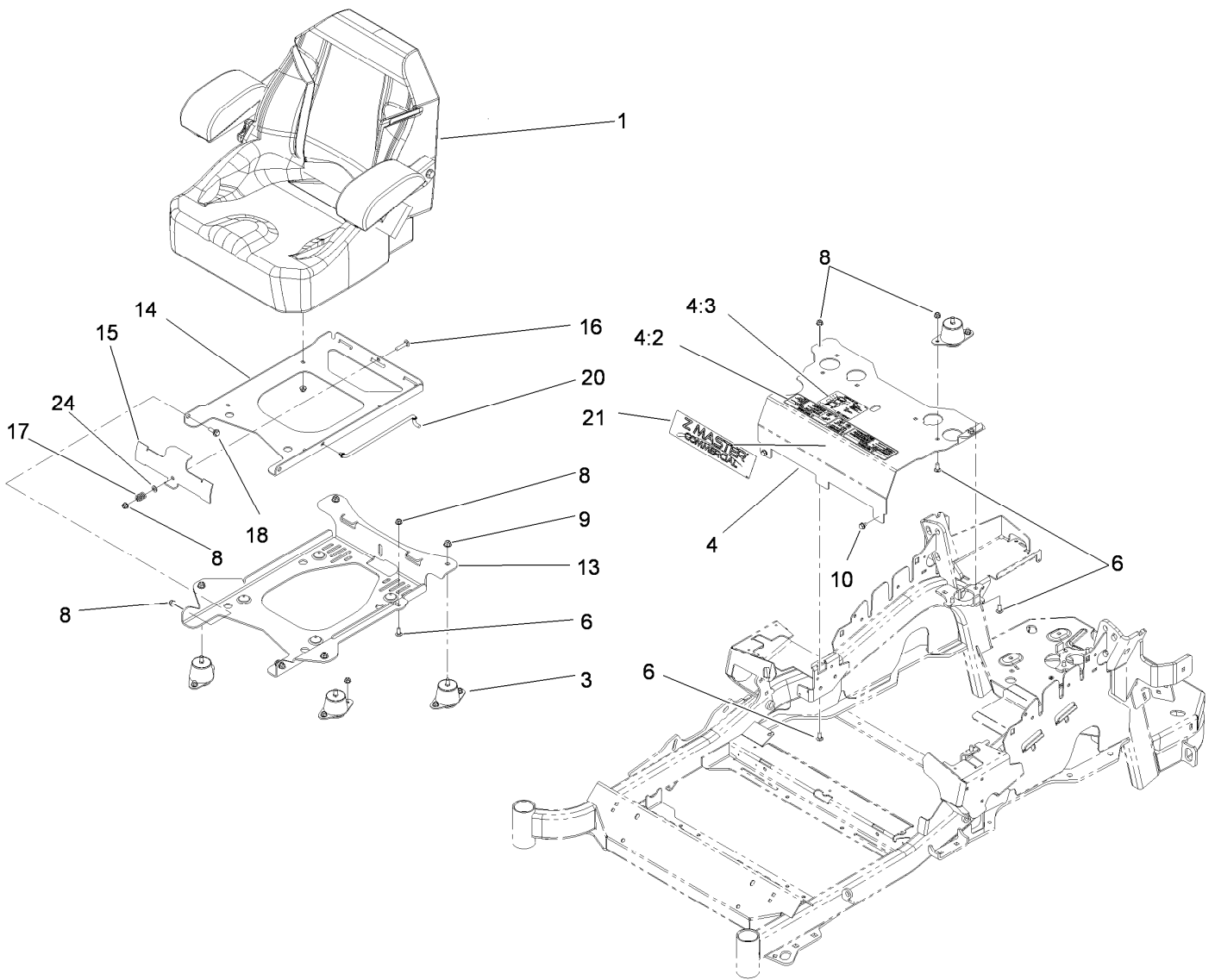

Seat Mounting Assembly

Ref.	Part Number	Qty.	Description	Ref.	Part Number	Qty.	Description
1	116-0035	1	Seat-Standard	13	116-0181-03	1	Plate-Support, Seat Tilt
3	109-9034	4	Isolator-Seat	14	116-0179-03	1	Plate-Frame, Seat Tilt
4	109-9036	1	Mount-Seat	15	109-9881-03	1	Plate-Latch, Seat
4:2	109-7069	1	Decal-Console	16	3230-4	1	Screw-CARR
4:3	116-0211	1	Decal-Service Aid	17	107-3017	1	Spring-Compression
6	3230-23	11	Screw-CARR	18	116-1297	2	Screw, Shoulder
8	104-8300	18	Nut-Flange, NI	20	116-0070	1	Rod-Prop
9	104-8301	4	Nut-Flange, NI	21	114-5878	1	Decal-Dash
10	9266934	2	Screw	24	3256-23	1	Washer-Flat

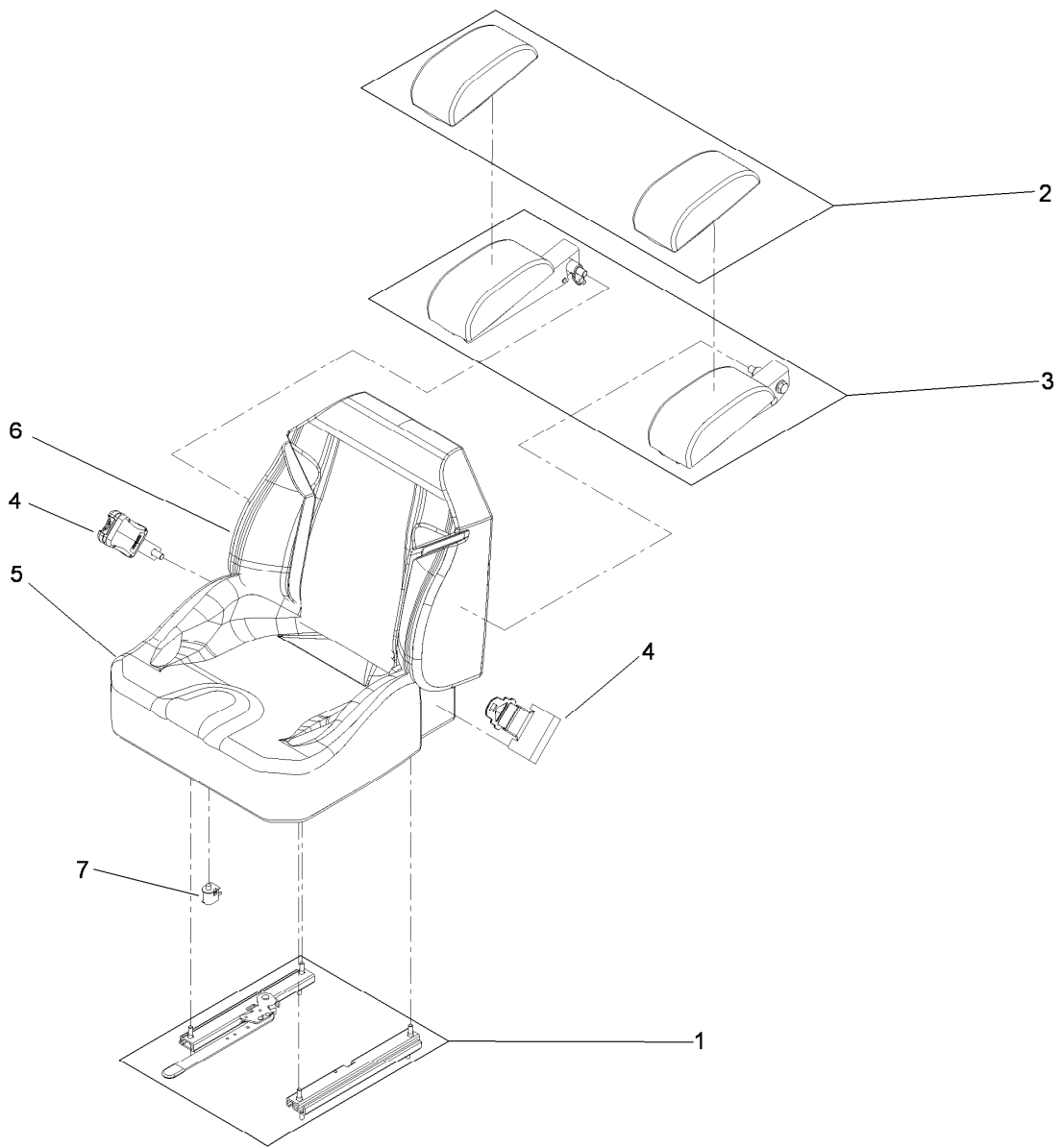

Seat Assembly No. 116-0035

<i>Ref.</i>	<i>Part Number</i>	<i>Qty.</i>	<i>Description</i>
1	109-9801	1	Seat Track Set
2	109-9802	1	Arm Rest Pad Set
3	109-9803	1	Arm Rest Set
4	109-9805	1	Seat Belt Kit
5	109-9806	1	Cover-Cushion
6	109-9808	1	Cover-Back
7	82-2190	1	Switch-Bail

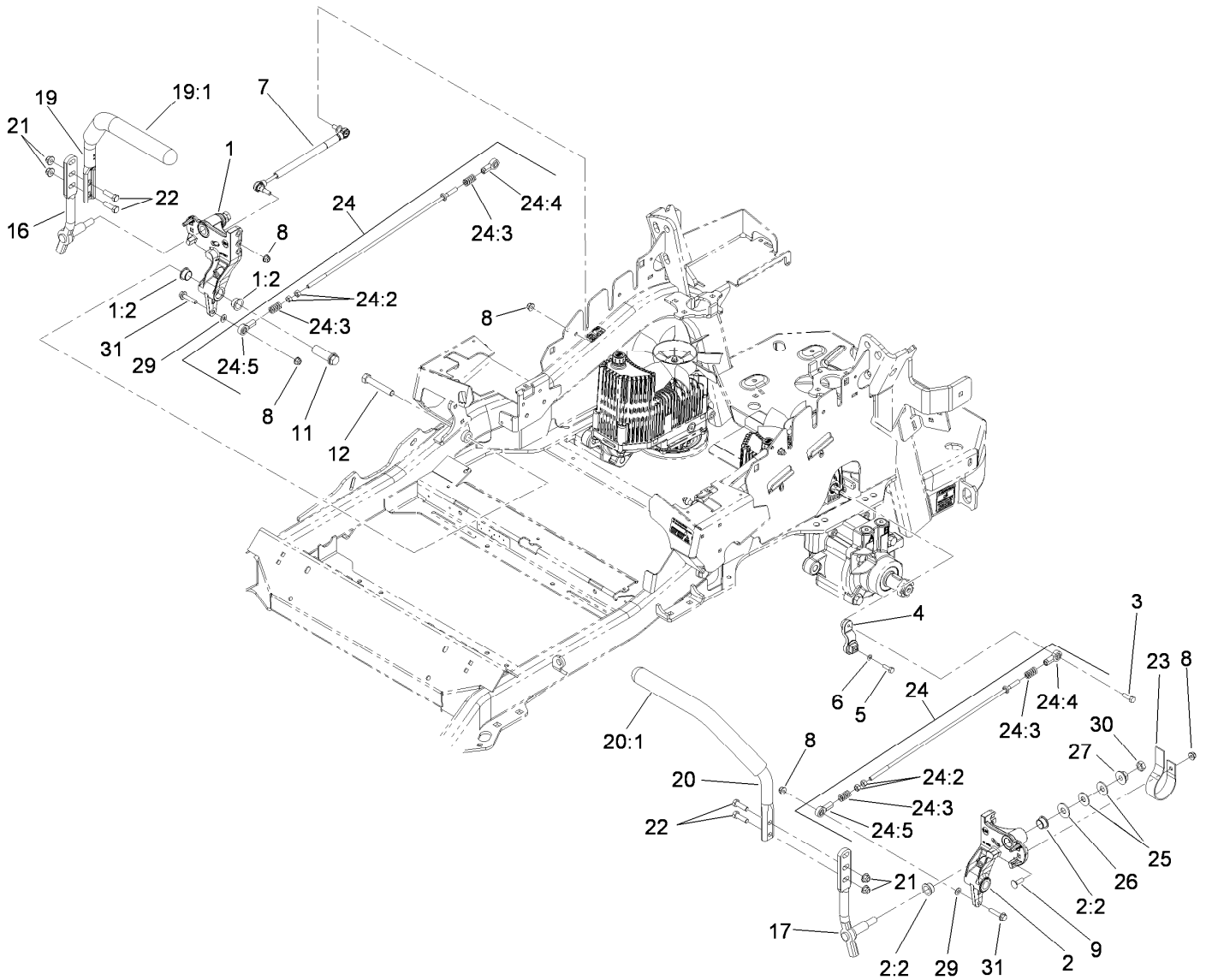

Motion Control Assembly

Ref.	Part Number	Qty.	Description	Ref.	Part Number	Qty.	Description
1	116-0880	1	RH Motion Control And Bushing ASM	19:1	106-9987	1	Grip-Control, Motion
1:2	109-8054	4	Bushing-Flange	20	109-6592	1	LH Steering Handle ASM
2	116-0881	1	LH Motion Control And Bushing ASM	20:1	106-9987	1	Grip-Control, Motion
2:2	109-8054	4	Bushing-Flange	21	104-8301	4	Nut-Flange, NI
3	116-0648	2	Screw-Thread Locking	22	323-7	4	Screw-HH
4	109-4581	2	Arm-Control, Pump	23	109-5575	2	Spring-Leaf
5	9080046	2	Screw-HH	24	109-8106	2	Front Pump Linkage ASM
6	1-303435	2	Washer-Spring	24:2	3219-2	2	Nut-Hex
7	116-0027	2	Damper-Control, Motion	24:3	1-323245	2	Spring-Compression
8	104-8300	8	Nut-Flange, NI	24:4	1-633152	1	Balljoint-LH
9	3230-2	2	Bolt-CARR	24:5	1-543017	1	Balljoint-RH
11	109-5891	2	Hub-Threaded	25	109-9505	4	Washer-Spring
12	325-12	2	Screw-HH	26	3256-6	2	Washer-Flat
16	116-0039	1	Lever-Control Motion, RH	27	32128-56	2	Nut-HF
17	116-0040	1	Lever-Control Motion, LH	29	3256-23	2	Washer-Flat
19	109-6591	1	RH Steering Handle ASM	30	3218-5	2	Nut-Jam
				31	115-1794	2	Screw-HHF

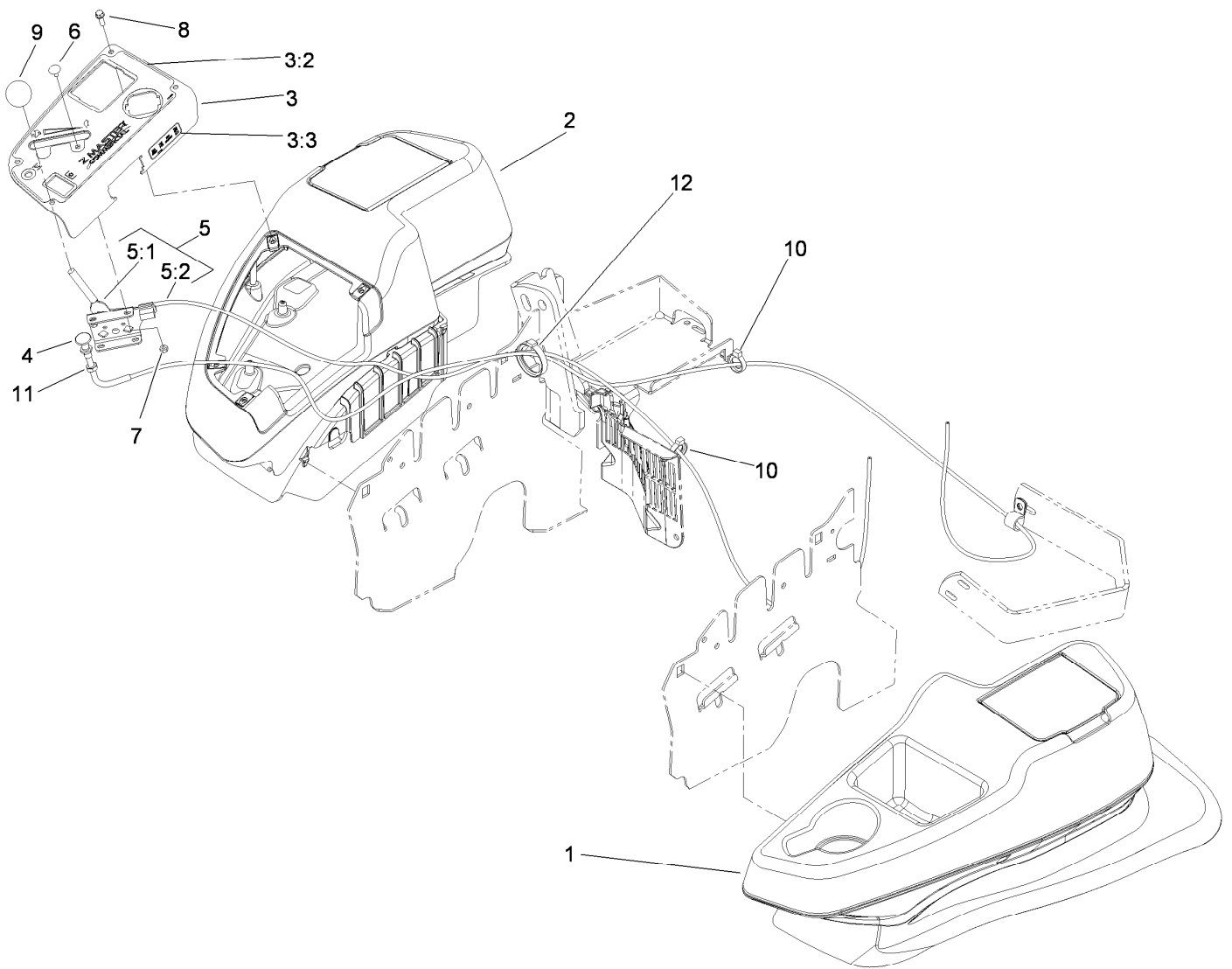

Fender, Console and Control Assembly

<i>Ref.</i>	<i>Part Number</i>	<i>Qty.</i>	<i>Description</i>	<i>Ref.</i>	<i>Part Number</i>	<i>Qty.</i>	<i>Description</i>
1	115-7401	1	LH Wide Fender/Console ASM	5:1	112-2334	1	Lever-Throttle
2	115-7400	1	RH Wide Fender/Console ASM	5:2	115-3866	1	Cable-Throttle
3	114-9836	1	Control Panel ASM	6	1-807513	2	Bolt-CARR
3:2	114-9834	1	Decal-Panel, Control	7	3296-2	2	Nut-Lock, NI
3:3	114-4466	1	Decal-Fuses	8	32105-15	4	Screw
4	115-2754	1	Control-Choke ASM	9	1-603175	1	Knob-Ball
5	115-2751	1	Control-Throttle ASM	10	105-1853	3	Clamp-Hose
				11	3220-3	1	Nut-HJ
				12	117-7817	1	Clamp-Harness

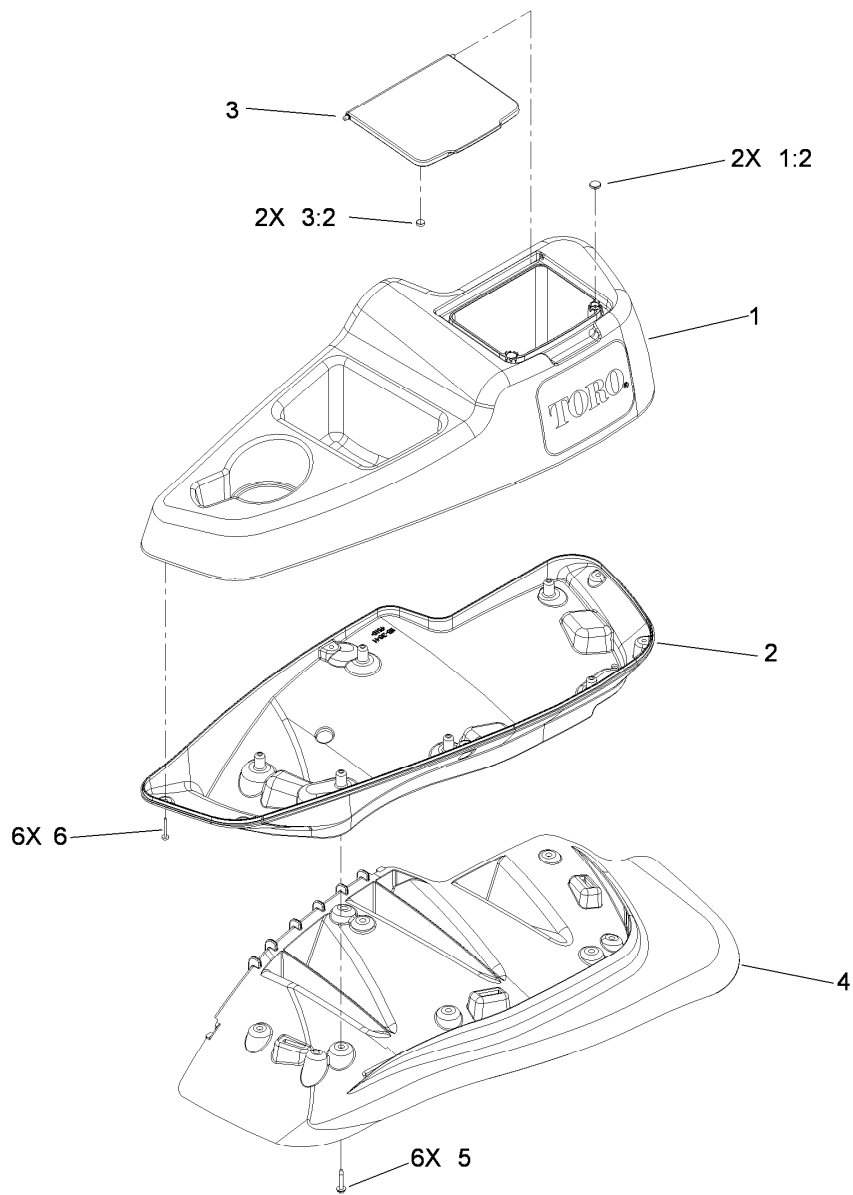

LH Console Assembly No. 115-7401

<i>Ref.</i>	<i>Part Number</i>	<i>Qty.</i>	<i>Description</i>
1	114-1539	1	LH Wide Console Top ASM
1:2	117-0883	2	Puck
2	115-3641	1	Console-Lwr, LH Wide
3	114-1537	1	Wide Lid ASM
3:2	114-5896	2	Magnet
4	109-9085	1	Fender-Wide, LH
5	32144-89	6	Screw-Thread Forming
6	117-0347	6	Screw-Fillister Head

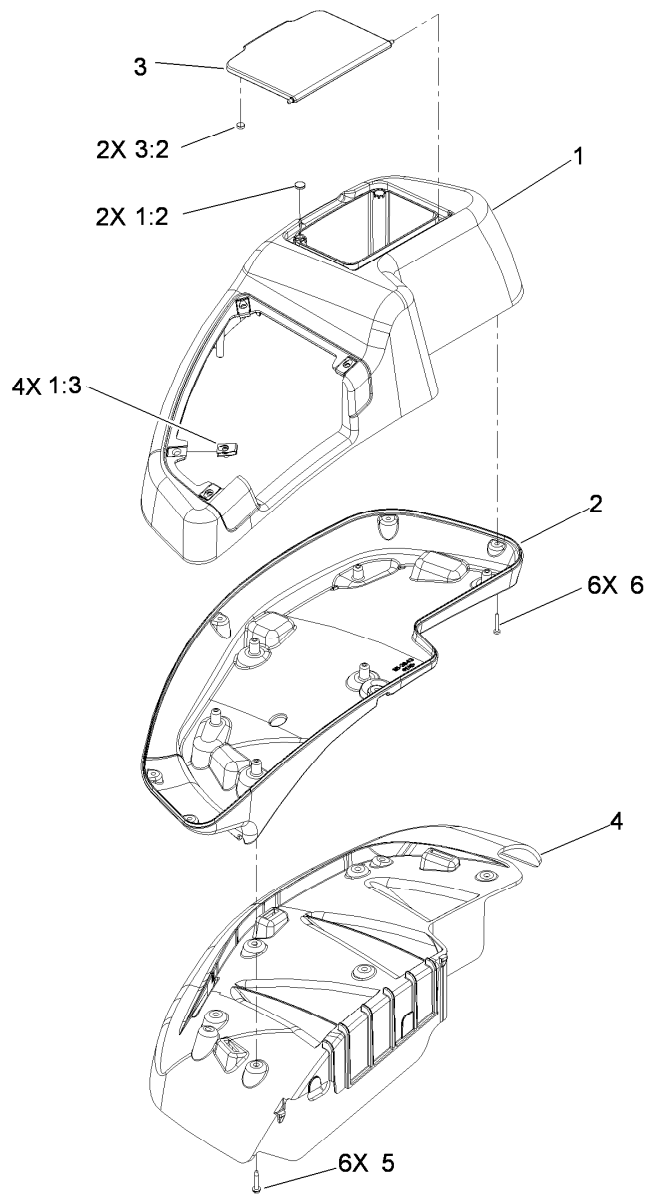

RH Console Assembly No. 115-7400

<i>Ref.</i>	<i>Part Number</i>	<i>Qty.</i>	<i>Description</i>
1	114-1538	1	RH Wide Top Console ASM
1:2	117-0883	2	Puck
1:3	107069	4	Clip
2	115-3643	1	Console-Lwr, RH Wide
3	114-1537	1	Wide Lid ASM
3:2	114-5896	2	Magnet
4	109-9083	1	Fender-Wide, RH
5	32144-89	6	Screw-Thread Forming
6	117-0347	6	Screw-Fillister Head

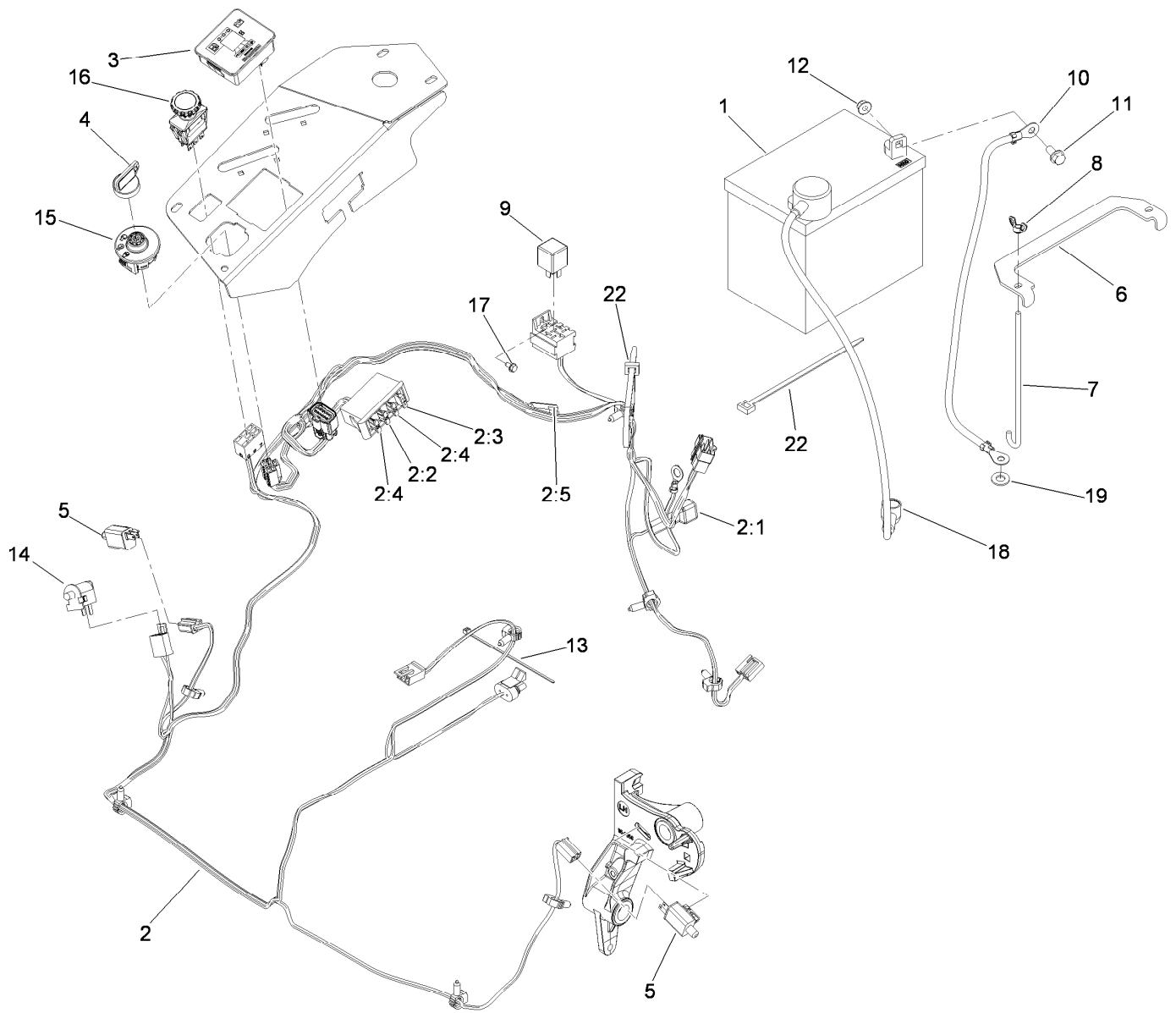

Electrical System Assembly

<i>Ref.</i>	<i>Part Number</i>	<i>Qty.</i>	<i>Description</i>
1	104-2492	1	Battery
2	115-2796	1	Harness-Wire, Main
2:1	103-3895	1	Diode-Tvs
2:2	218-578	1	Fuse-10 Amp
2:3	109355	1	Fuse-15 Amp
2:4	109102	2	Fuse-25 Amp
2:5	116-0053	1	Cap-Plug
3	116-1355	1	Fuel/Hour Meter ASM
4	63-8360	1	Key-Ignition
5	110-6765	2	Switch-Single Pole No
6	116-0042-03	1	Strap-Tie Down, Battery
7	1-633651	2	Bolt-Holddown
8	1-543792	2	Wingnut

<i>Ref.</i>	<i>Part Number</i>	<i>Qty.</i>	<i>Description</i>
9	1-643275	1	Relay
10	114-1218	1	Cable-Battery, Negative
11	3234-5	2	Screw-HHF
12	104-8300	2	Nut-Flange, NI
13	1-303287	3	Tie-Plastic
14	82-2190	1	Switch-Bail
15	117-2221	1	Switch-Ignition
16	116-0124	1	Switch-PTO, 10A
17	104-2065	1	Screw-HWH
18	115-3864	1	Cable-Battery, Positive
19	3256-24	1	Washer-Flat
22	1-303335	1	Tie-Plastic

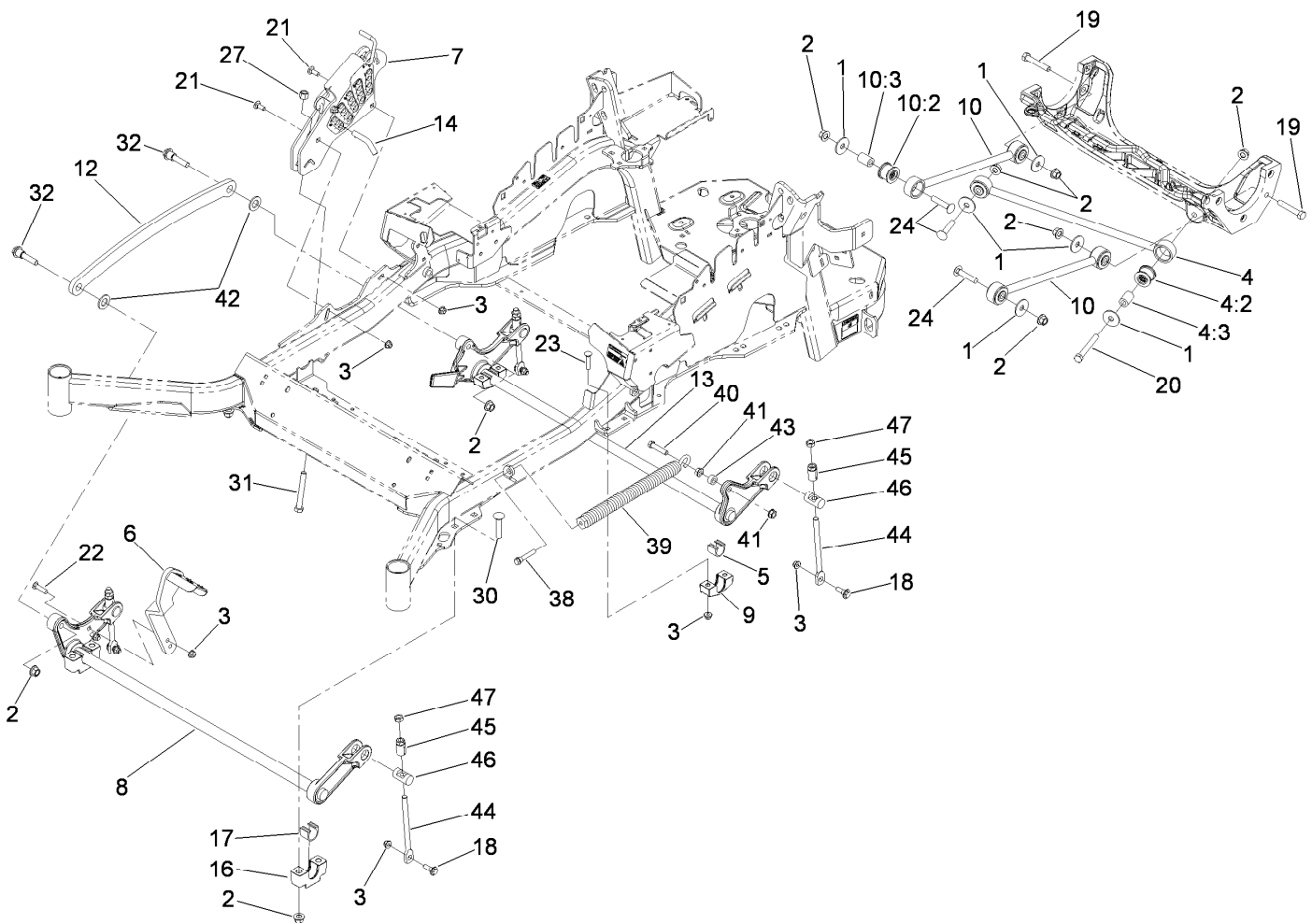

Deck Lift Assembly

Ref.	Part Number	Qty.	Description	Ref.	Part Number	Qty.	Description
1	86-1990	6	Washer	17	109-9410	2	Bearing-Shaft Front, Cross
2	99-5107	12	Nut-Lock	18	109-9840	4	Screw-Shoulder, HHF
3	104-8301	12	Nut-Flange, NI	19	325-12	2	Screw-HH
4	109-5013	1	Panhard Rod ASM	20	325-17	1	Screw-HH
4:2	109-5009	2	Bushing-Suspension, Rubber	21	3231-2	2	Screw-CARR
4:3	109-5010	2	Spacer	22	3231-4	2	Screw-CARR
5	109-7173	2	Bearing-Cross, Rear Shaft	23	3231-5	4	Screw-CARR
6	116-1919-01	1	Lever-Foot	24	3233-34	3	Screw-CARR
7	109-7438	1	HOC ASM	27	3296-23	1	Nut-Lock, NI
8	116-1771-03	1	Deck Lift-Front	30	3233-37	4	Screw-CARR, Short Neck
9	116-0818-03	2	Support-Bearing, Cross Shaft Rear	31	116-0559	1	Bolt-TAP
10	109-7952	2	Deck Strut ASM	32	116-2022	2	Screw-HHF, Shoulder
10:2	109-5009	2	Bushing-Suspension, Rubber	38	92-7674	1	Bolt-Shoulder
10:3	109-5010	2	Spacer	39	116-0000	1	Extension Spring ASM
12	116-0797-03	1	Link-Lift, Deck	40	109-9065	1	Screw-HH
13	116-2645-03	1	Lift-Deck, Rear	41	32128-37	2	Nut-HF
14	109-8757	1	Pin-HOC	42	3256-28	2	Washer-Flat
16	109-9409	2	Support-Cross Shaft, Bearing Front	43	116-2695	1	Spacer
				44	109-8007	4	Link-Adjuster, Deck Lift
				45	109-7840	4	Adjuster-Lift, Deck
				46	109-8353	4	Trunnion
				47	3218-5	4	Nut-Jam

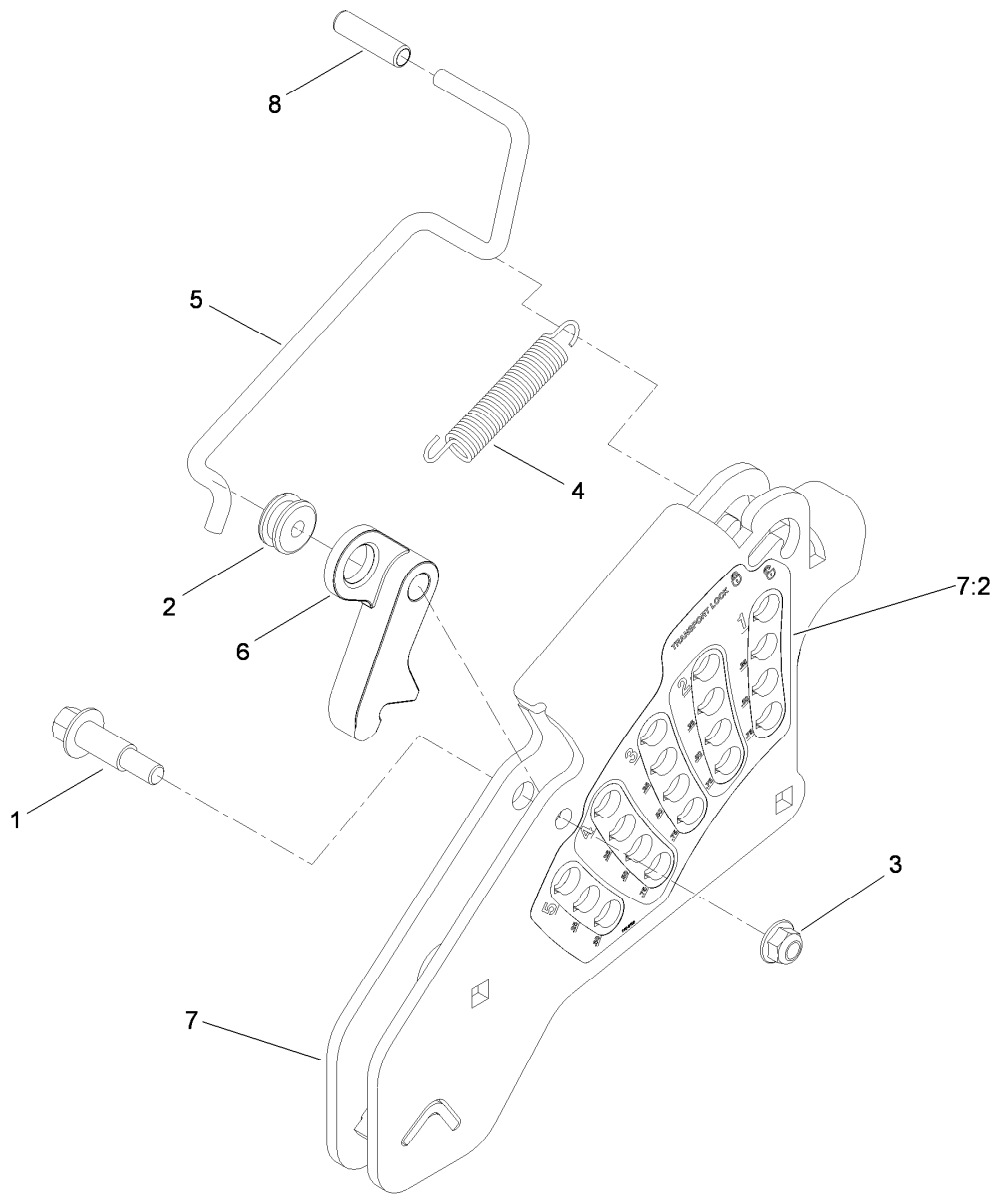

Height-of-Cut Assembly No. 109-7438

<i>Ref.</i>	<i>Part Number</i>	<i>Qty.</i>	<i>Description</i>
1	62-1330	1	Bolt-Shoulder
2	109-7130	1	Grommet
3	104-8301	1	Nut-Flange, NI
4	109-7124	1	Spring-Extension
5	109-7128	1	Rod-Lock, Transport
6	116-0118	1	Pawl-Transport, HOC
7	109-7335	1	HOC Plate ASM
7:2	116-0752	1	Decal-HOC
8	109-8250	1	Grip-Lever

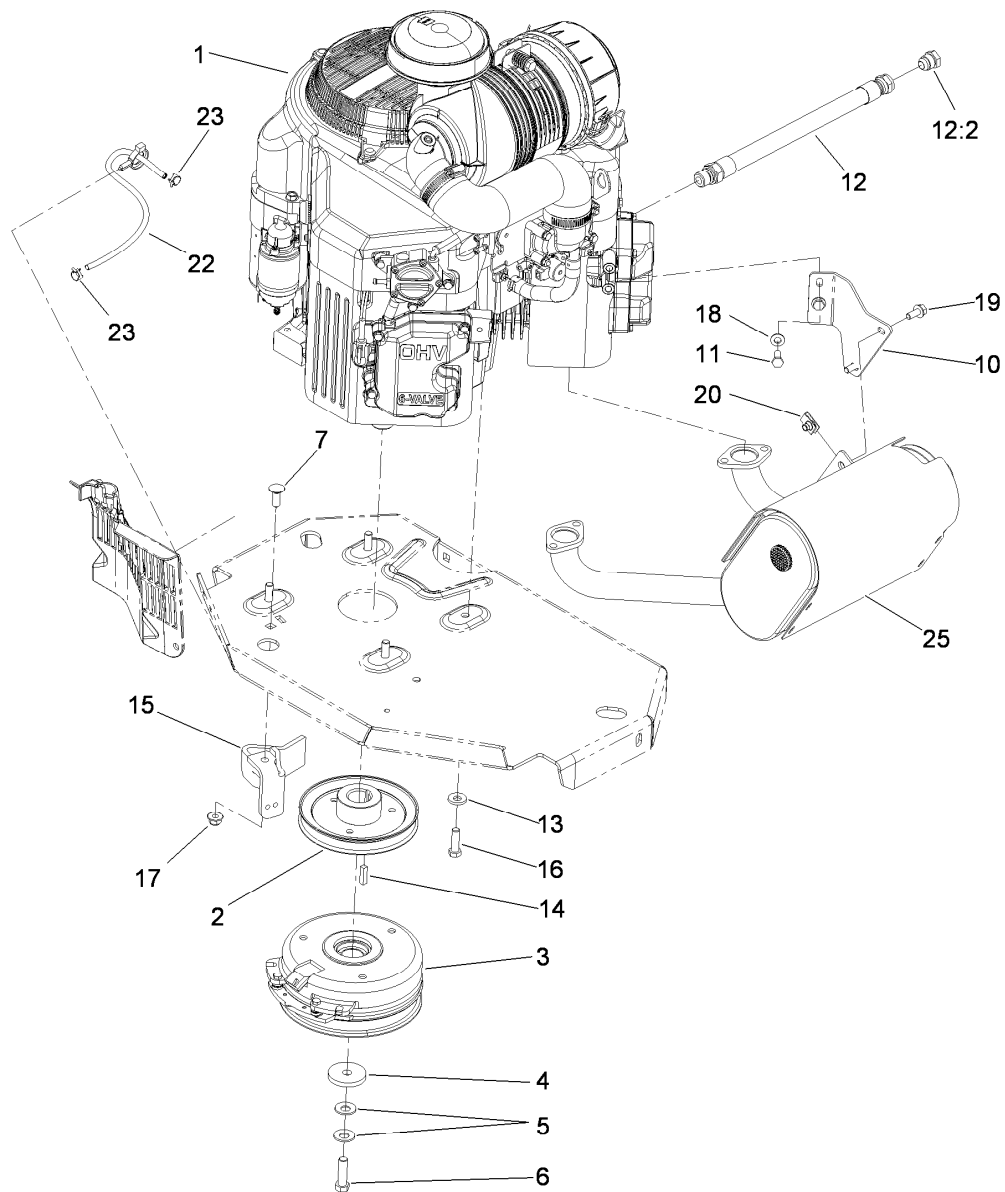

Engine, Clutch and Muffler Assembly

Ref.	Part Number	Qty.	Description	Ref.	Part Number	Qty.	Description
1		1	Engine-Kawasaki, Fx921V-As04 ●■	13	98-5975	4	Washer-Belleville
2	109-9905	1	Sheave	14	1-807259	1	Key
3	116-1621	1	Clutch Kit	15	116-2612-01	1	Clutch-Anchor
4	109-6919	1	Washer-Clutch	16	323-7	4	Screw-HH
5	1-603610	2	Washer-Spring	17	104-8301	1	Nut-Flange, NI
6	109-9761	1	Screw-HH W/Loctite	18	1-303334	2	Washer-Spring
7	3231-22	1	Screw-CARR	19	3234-5	2	Screw-HHF
10	116-1587	1	Bracket-Muffler	20	94-2413	2	U-Nut
11	33114-020	2	Screw-HH	22	109-0296	1	Hose-Fuel
12	109-4490	1	Oil Drain Hose ASM	23	2412-98	2	Clamp
12:2	109-1012	1	Plug	25	116-1707	1	Muffler

● Not serviced separately

■ Obtain parts from www.kawpowerepc.com

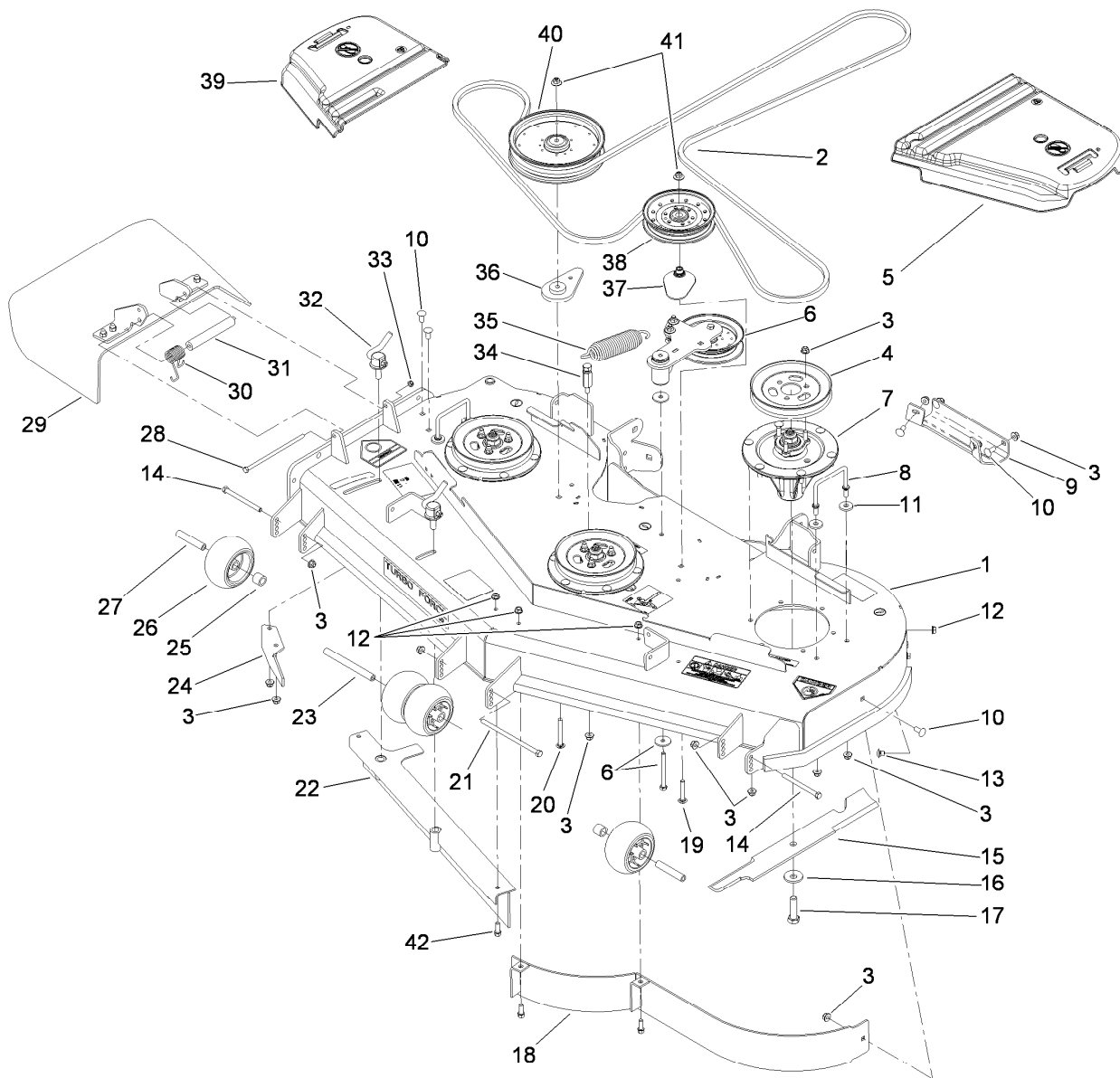

Deck Assembly

Ref.	Part Number	Qty.	Description	Ref.	Part Number	Qty.	Description
1	112-4180	1	Deck Decal ASM	20	3231-42	1	Screw-CARR
2	114-5858	1	Belt-V	21	108-5388	1	Screw-HH
3	104-8301	42	Nut-Flange, NI	22	105-7669-01	1	Baffle ASM
4	105-7734	3	Pulley	23	98-5967	1	Spacer-Wheel
5	109-6938	1	Cover-Belt, LH	24	106-3216-01	1	Baffle-Discharge
6		1	Idler Arm ASM ●	25	98-7913	2	Tube-Spacer
7	117-6159	3	Spindle ASM	26	1-603299	4	Roller-Scalp, Anti
8	109-6982	2	Wireform-Cover	27	98-7912	2	Tube-Spanner
9	105-8792-01	1	Plate-Skid	28	322-50	1	Screw-HH
10	3231-27	7	Screw-CARR	29	108-2792	1	Rubber Deflector ASM
11	1-373034	4	Washer	30	108-4052	1	Spring-Torsion
12	3290-357	6	Nut-HHF, Whiz	31	105-4622	1	Spacer
13	108-5387	3	Screw-CARR	32	107-1664	2	Lever ASM
14	323-23	2	Screw-HH	33	3296-47	1	Nut-Lock, NI
15	105-7718-03	3	Blade-Hi Flow	34	114-5867	1	Anchor-Spring, Tall
16	103-0865	3	Washer-Blade Bolt, Heavy	35	116-0133	1	Extension-Spring
17	51-4060	3	Screw-Blade	36	109-9416	1	Spacer-Idler
18	114-5842-01	1	Baffle ASM	37	109-2872	1	Spacer-Pulley
19	3231-40	1	Bolt-CARR	38	114-5895	1	Pulley-Idler, Flat

● Not serviced separately

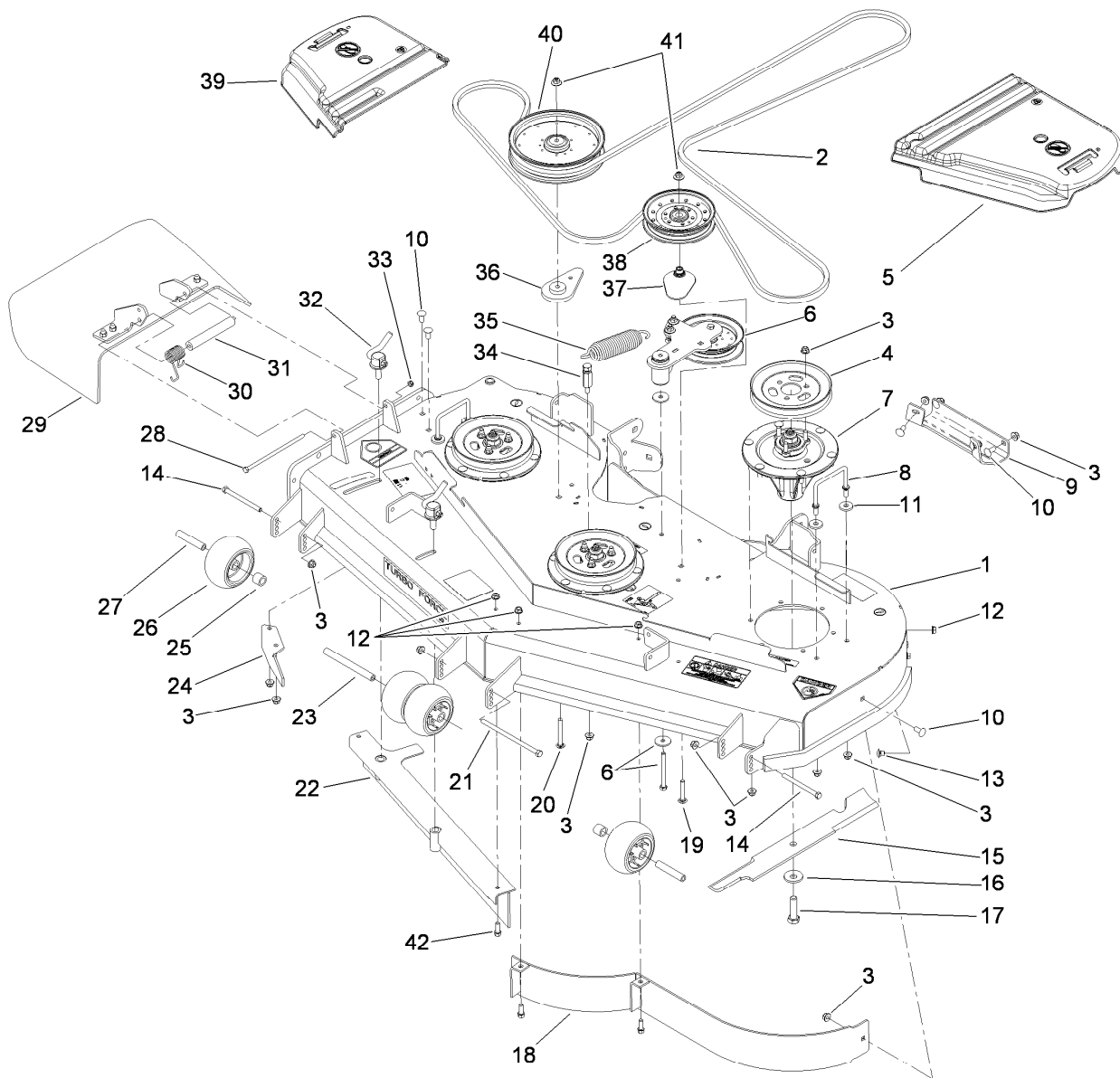

Deck Assembly (continued)

<i>Ref.</i>	<i>Part Number</i>	<i>Qty.</i>	<i>Description</i>	<i>Ref.</i>	<i>Part Number</i>	<i>Qty.</i>	<i>Description</i>
39	116-0094	1	Cover-Belt, RH	41	109-6658	2	Nut-Flange, NI (Split)
40	109-8590	1	Pulley-Idler	42	92-1624	3	Screw-HWH

● Not serviced separately

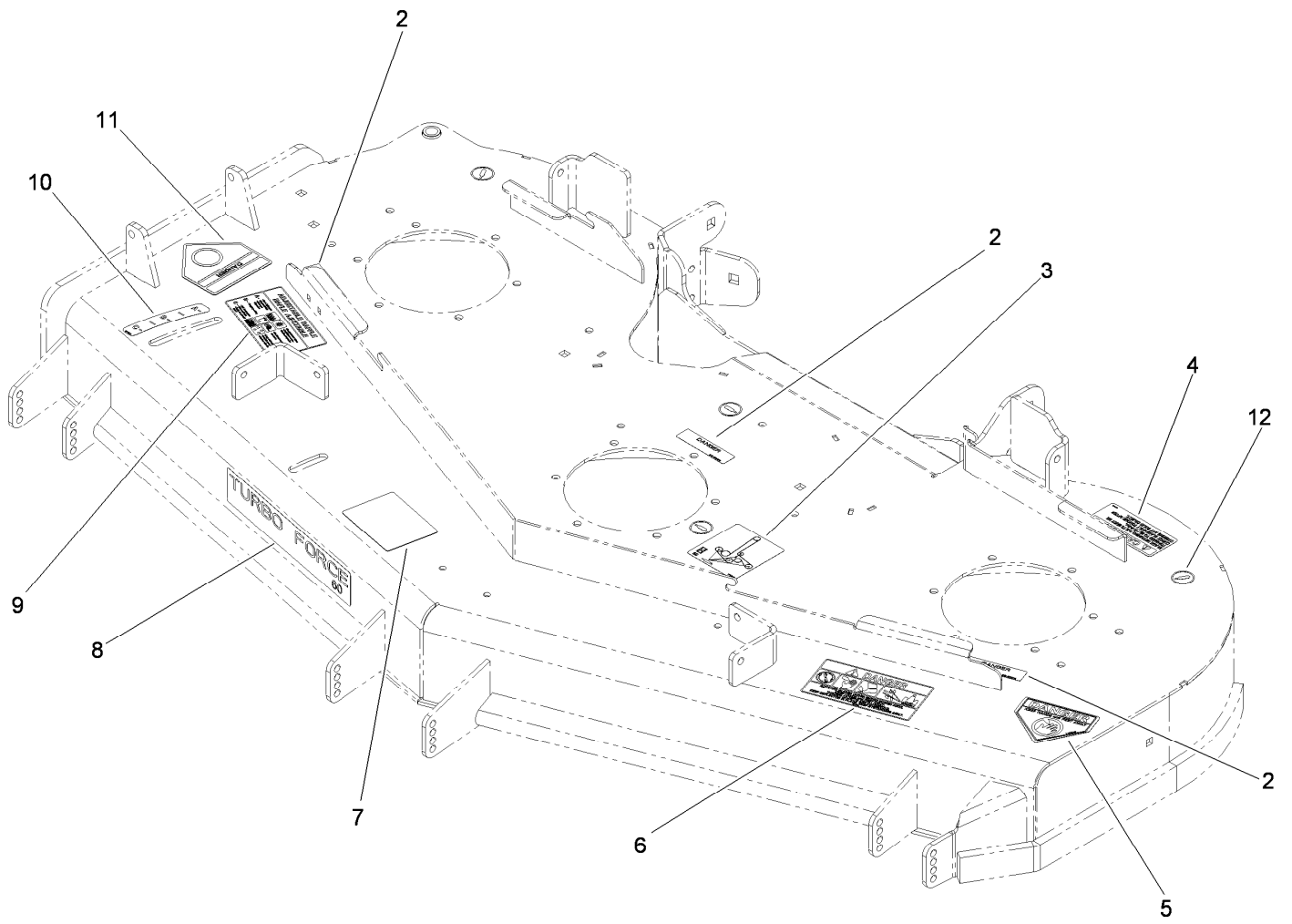

Deck Decal Assembly No. 112-4180

<i>Ref.</i>	<i>Part Number</i>	<i>Qty.</i>	<i>Description</i>
2	98-5954	3	Decal-Cover, Missing
3	115-7445	1	Decal-Routing, Deck Belt
4	68-8340	1	Decal-Torque
5	1-403005	1	Decal-Danger
6	66-1340	1	Decal-Danger, Thrown Object
7	105-7798	1	Decal-Scalp, Anti
8	107-1619	1	Decal
9	110-2068	1	Decal-Adjustment, Baffle
10	110-2067	1	Decal-Setting, Baffle
11	54-9220	1	Decal-Danger
12	58-6520	4	Decal-Grease

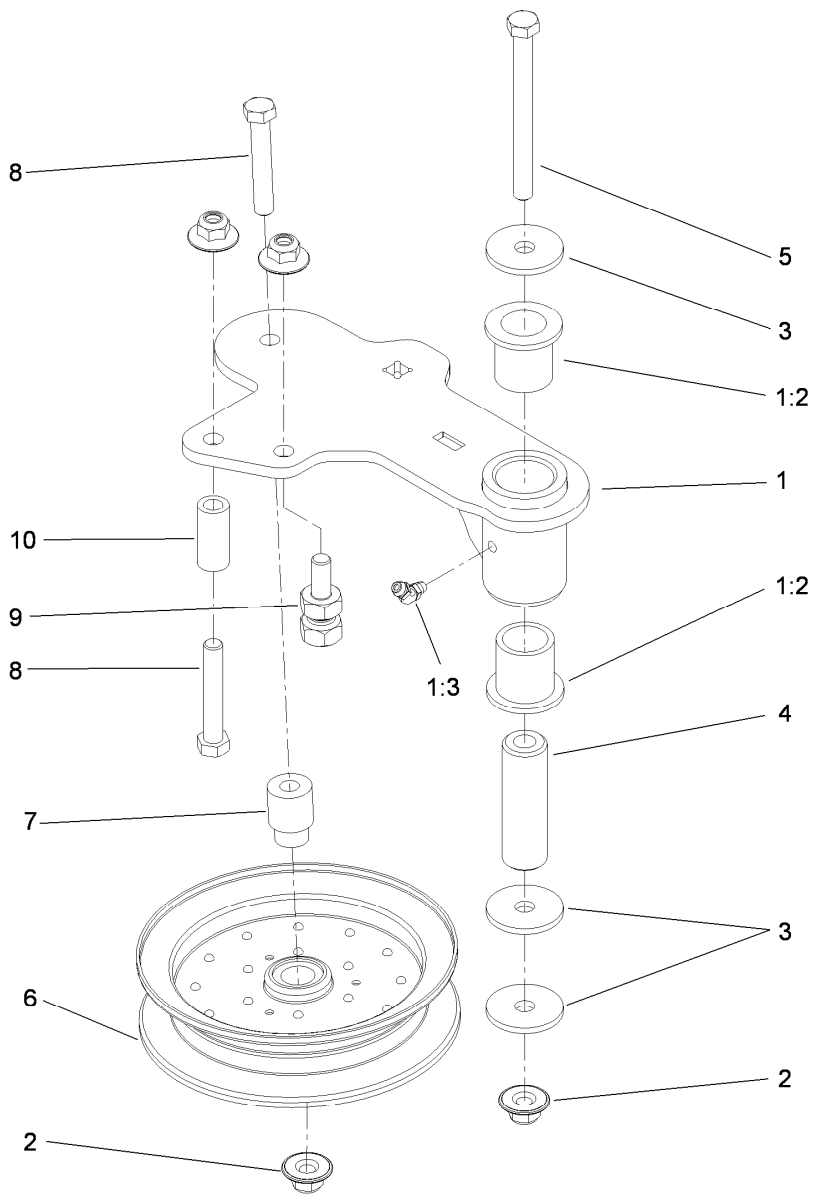

Idler Assembly

Ref.	Part Number	Qty.	Description
1	114-5870	1	Idler Arm ASM
1:2	1-303514	2	Bearing-Flanged
1:3	1481	1	Fitting-Grease
2	109-6658	4	Nut-Flange, NI (Split)
3	1-213069	3	Washer
4	114-5848	1	Spacer-Plain
5	98-5961	1	Screw-HH
6	103-8743	1	Pulley-Idler, Flanged
7	112-4212	1	Mount-Pulley
8	323-11	2	Screw-HH
9	114-5866	1	Anchor-Spring, Short
10	104-0151	1	Spacer

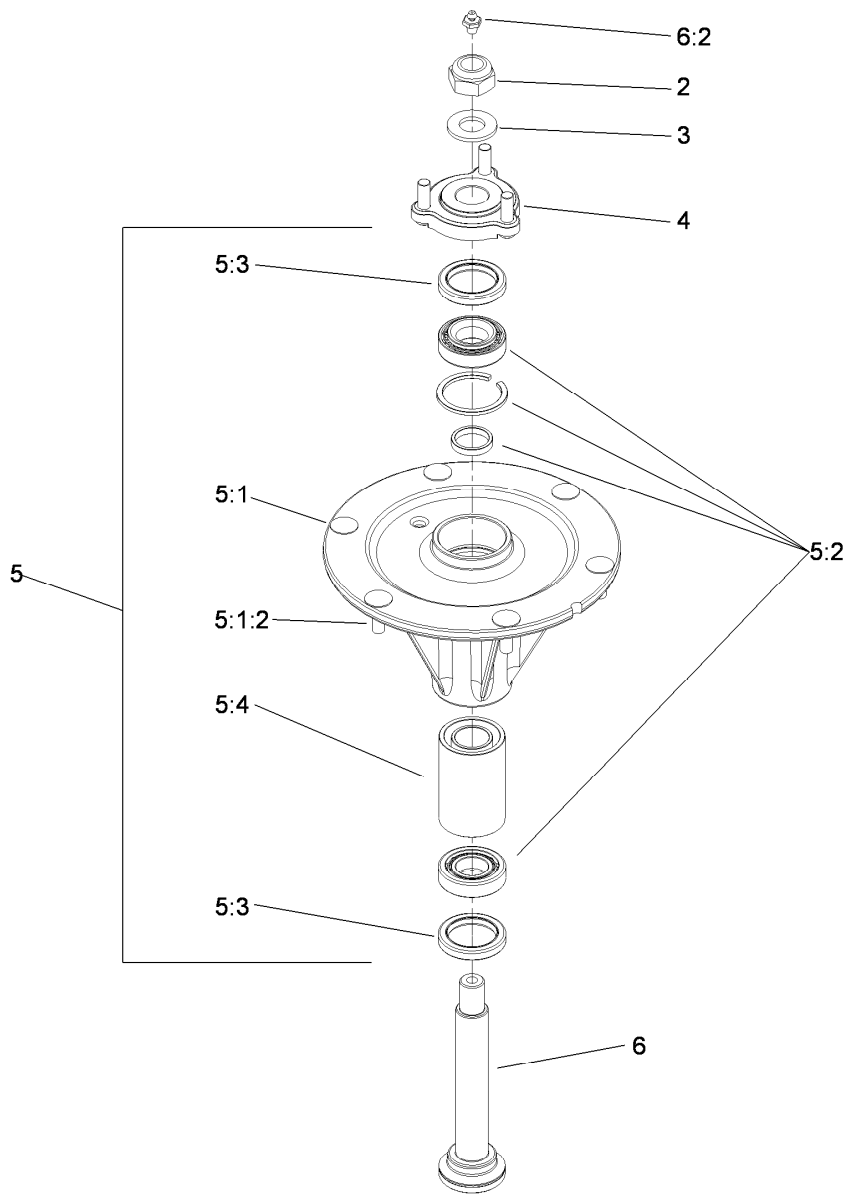

Spindle Assembly No. 117-6159

Ref.	Part Number	Qty.	Description
2	3296-67	1	Nut-Lock NI
3	92-5836	1	Washer
4	117-6172	1	Spindle Hub ASM W/Studs
5	117-6156	1	Spindle Housing And Tapered Bearings ASM
5:1		1	Trb Spindle Housing ASM W/Studs ●
5:1:2	114-8195	6	Bolt-Ribbed Neck
5:2	114-8163	1	Bearing ASM
5:3	253-133	2	Seal-Oil
5:4	117-6185	1	Spacer Set
6	119-1851	1	Spindle Shaft And Zerk ASM
6:2	302-2	1	Fitting-Grease

● Not serviced separately

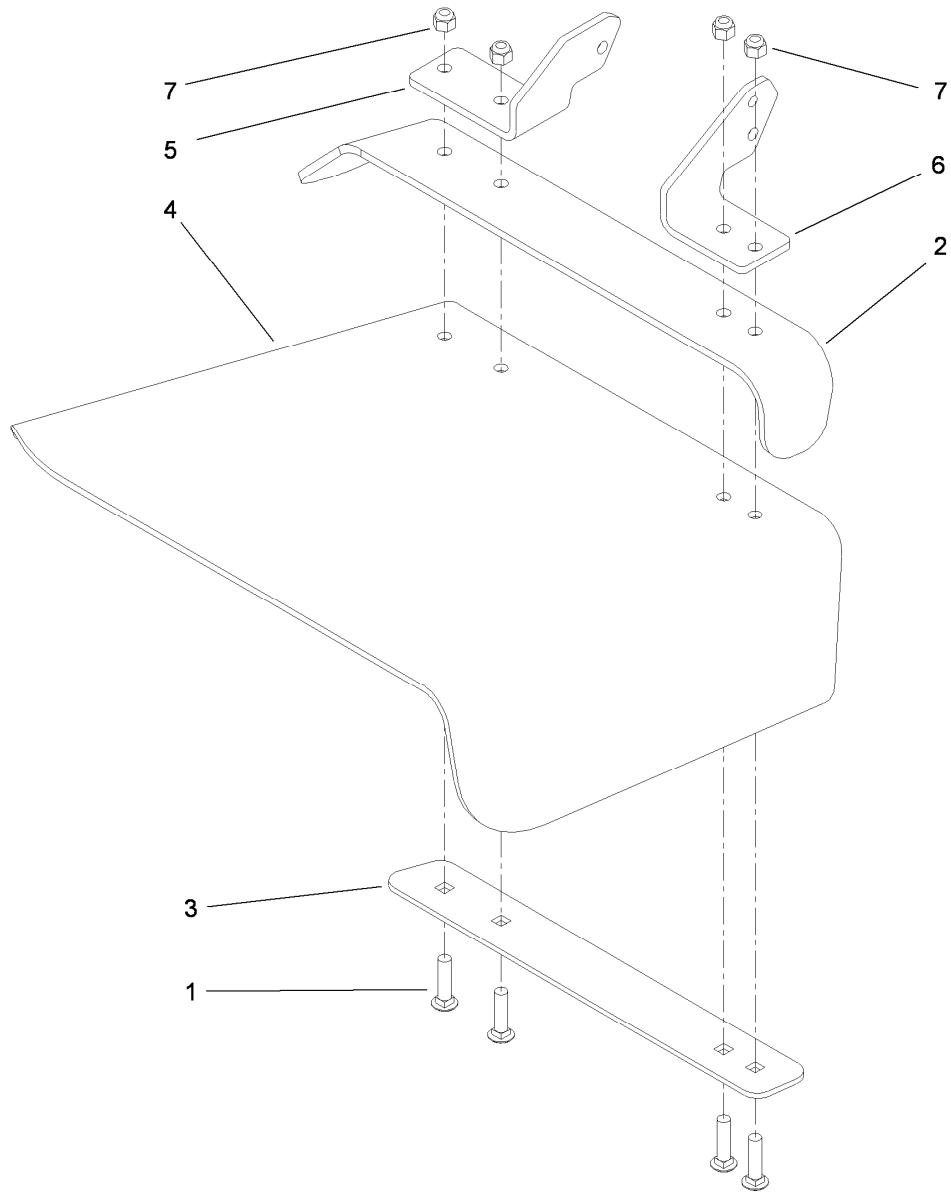

Rubber Deflector Assembly No. 108-2792

<i>Ref.</i>	<i>Part Number</i>	<i>Qty.</i>	<i>Description</i>
1	3231-4	4	Screw-CARR
2	106-3246-01	1	Deflector
3	106-3248-03	1	Strap-Discharge
4	108-5029	1	Deflector-Rubber
5	108-4059-01	1	Plate-Hinge, Rear
6	106-3253-01	1	Plate-Hinge, Front
7	3296-39	4	Nut-Lock, NI

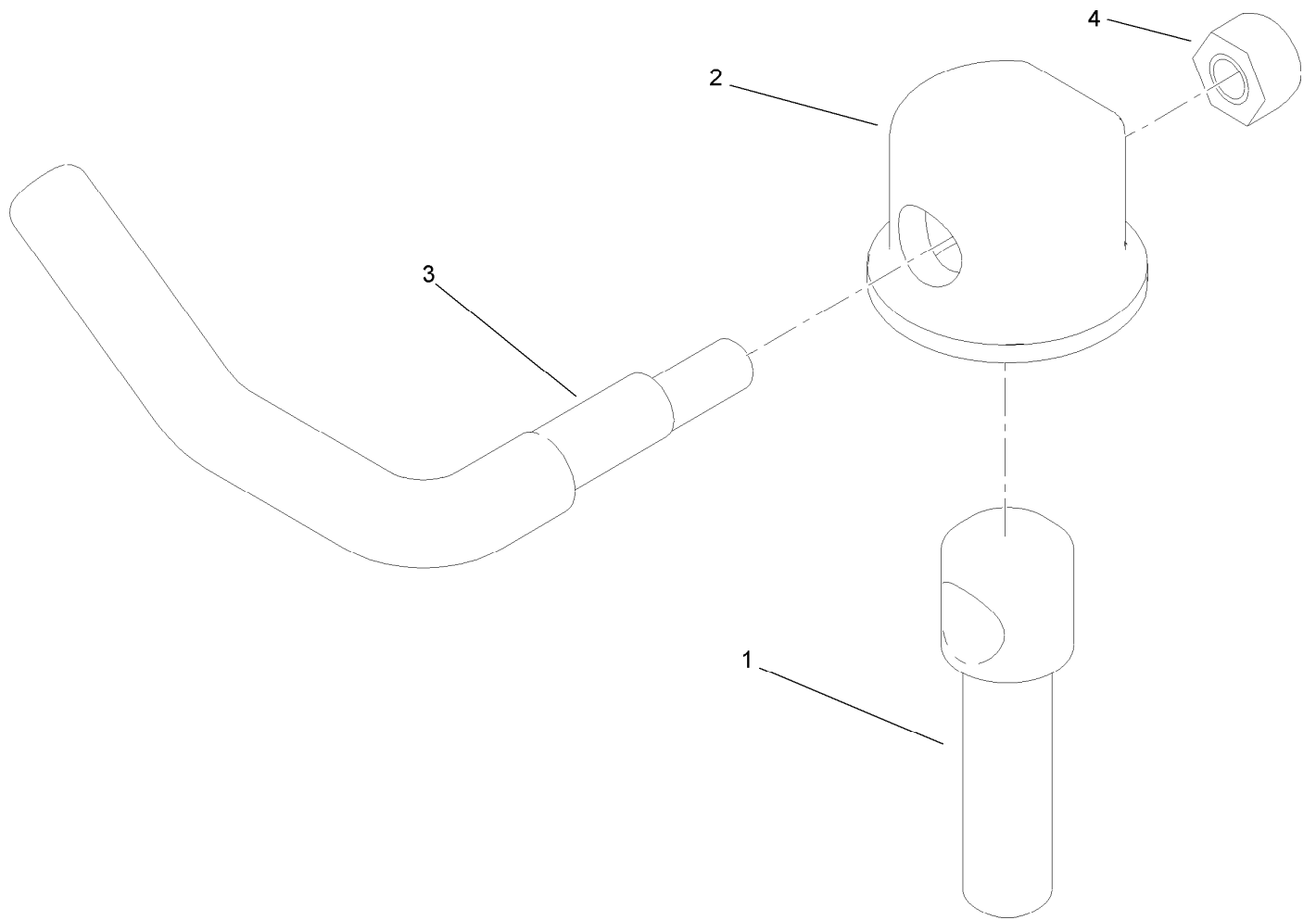

Lever Assembly No. 107-1664

<i>Ref.</i>	<i>Part Number</i>	<i>Qty.</i>	<i>Description</i>
1	106-3239	1	Screw-Lock
2	107-1644	1	Cap-Lock
3	106-3241	1	Lever-Lock
4	3296-29	1	Nut-Lock, NI

Attachments and Accessories

For 74935 Z Master G3 Riding Mower, with 60in TURBO FORCE Side Discharge Mower

Product Name	Model/Part
Blade-Mid Flow, 20.5 Inch.....	105-7715-03
Blade-Lo Flow, 20.5 Inch	105-7716-03
Blade-Hi Flow, 20.5 Inch	105-7718-03
Blade-Recycler, 20.5 Inch.....	105-7777-03
Blade-Atomic, 20.5 Inch.....	105-8777-03
6 Pack Blade, 20.5 Inch Hi-Flow	108-1114
6 Pack-Blade, 20.5 Inch Atomic.....	108-1115
6 Pack Blade, 20.5 Inch Mid-Flow.....	108-1123
6 Pack-Blade, 20.5 Inch Lo Flow	108-1128
Hitch Kit	109-9487
6 Pack-Blade, 20.5 Inch Recycler	110-0405
Hypr-oil 500 (quart).....	114-4713
Hypr-oil 500 (gallon)	114-4714
Hypr-oil 500-5 (5 Gallon).....	114-4715
Bimini Folding Shade Assembly	115-4510
Recycler Kit	115-7468
Roller Striper Kit.....	115-7470
Light Kit.....	116-1154
Z Stand Kit.....	117-0350
Operator-Controlled Discharge Chute Kit	117-3600
Deluxe Suspension Seat Kit	117-6174
Blower and Drive Kit	78553
E-Z Vac Triple Bagging System	78563
E-Z Vac DFS Collection System	78567
Trash Holder Kit.....	TC26

Notes:

Notes:

Notes:



Count on it.