

For:thomakf

Printed on:Mon, Oct 11, 2004 08:43:58

Document:3317-647

Last saved on:Mon, Oct 11, 2004 08:43:55



MODEL NO. 51324-59000001 & UP

PARTS CATALOG

12" ELECTRIC TRIMMER

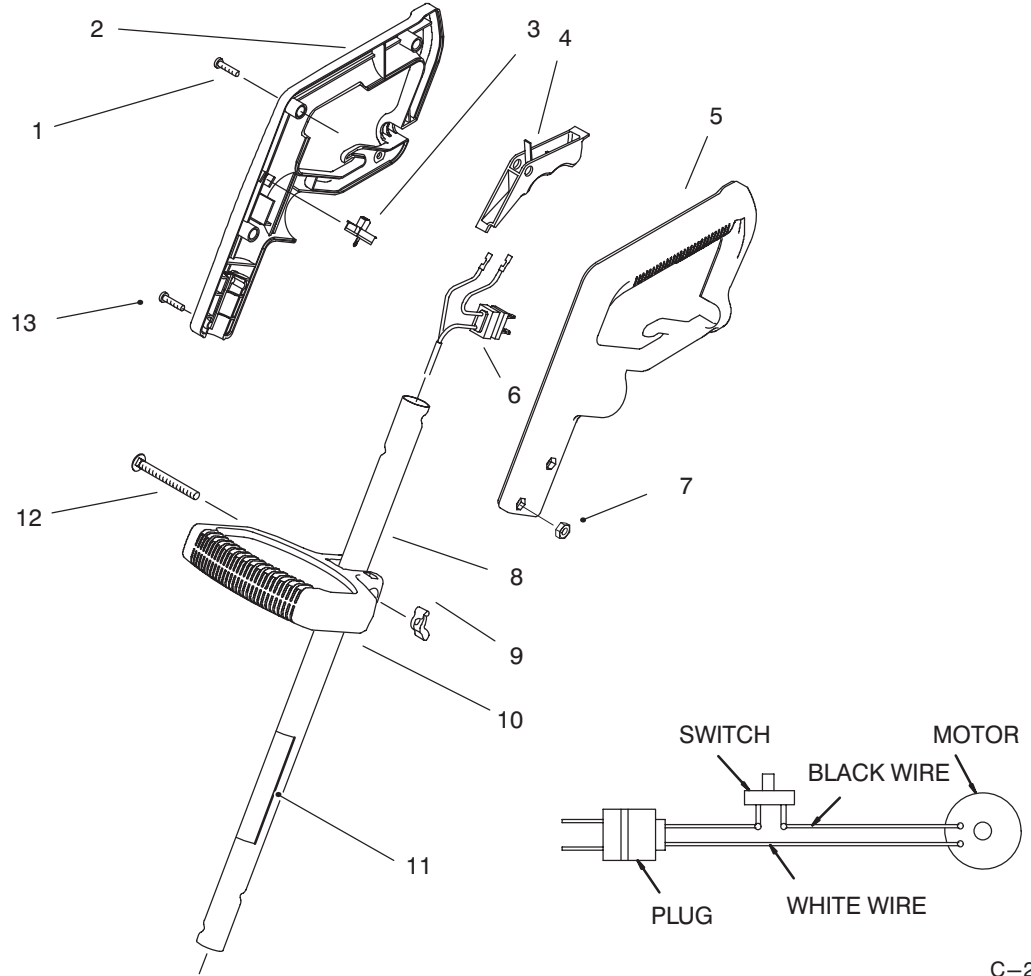

C-2331

HANDLE ASSEMBLY

Ref. No.	Part No.	Description	No. Used
1	94-4496	Screw - Pan Hd Tapping	4
2	73-8150	Grip - Hand R.H.	1
3	73-5600	Switch - Single Speed	1
4	73-8170	Trigger	1
5	73-8160	Grip - Hand L.H.	1
6	73-8380	Harness - Wire	1
7	3217-44	Nut - Lock	2

Ref. No.	Part No.	Description	No. Used
8	73-9130	Tube Assembly (Incl. Ref. #11)	1
9	32103-30	Nut - Wing	1
10	73-8310	Handle - Mid	1
11	93-4463	Decal - Safety	1
12	73-8740	Screw - Carriage	1
13	3250-52	Screw - Pan Hd.	2

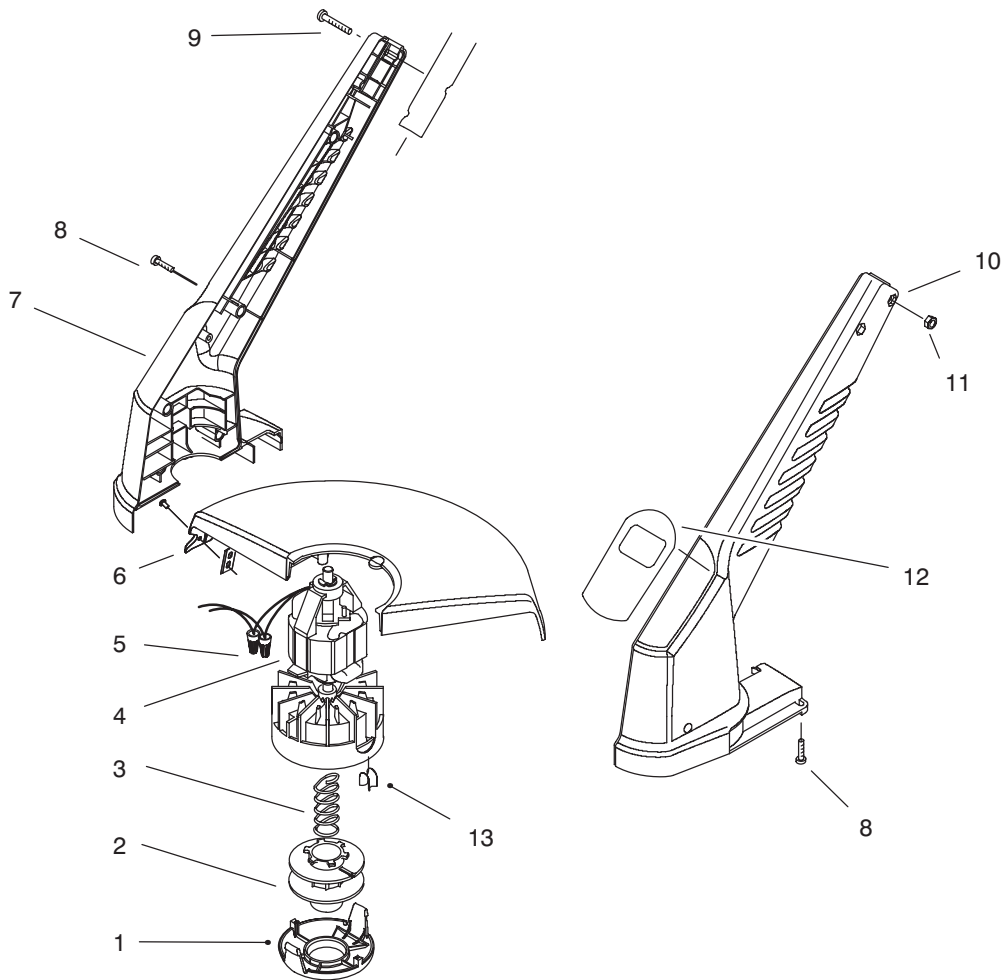

C-2330

MOTOR & HOUSING ASSEMBLY

Ref. No.	Part No.	Description	No. Used
1	73-8200	Cap	1
2	73-8190	Spool	1
3	73-8220	Spring	1
4	73-9051	Motor Assembly (Incl. Ref. #13)	1
5	73-6570	Connector - Wire Nut	2
6	73-9091	Shield - 12"	1
7	73-8130	Housing R.H.	1
8	94-4496	Screw - Pan Hd. Tapping	7

Ref. No.	Part No.	Description	No. Used
9	3250-52	Screw - Pan Hd.	2
10	73-8140	Housing L.H.	1
11	3217-44	Nut - Hex	2
12	73-8471	Decal - 12" Trimmer	1
13	73-8210	Eyelet	1
*	73-8510	Spool & Line Assembly (Incl. Ref. # 2) (Parts)	1
*	88175	Spool & Line Assembly (Whole Goods)	1

*Not Illustrated