

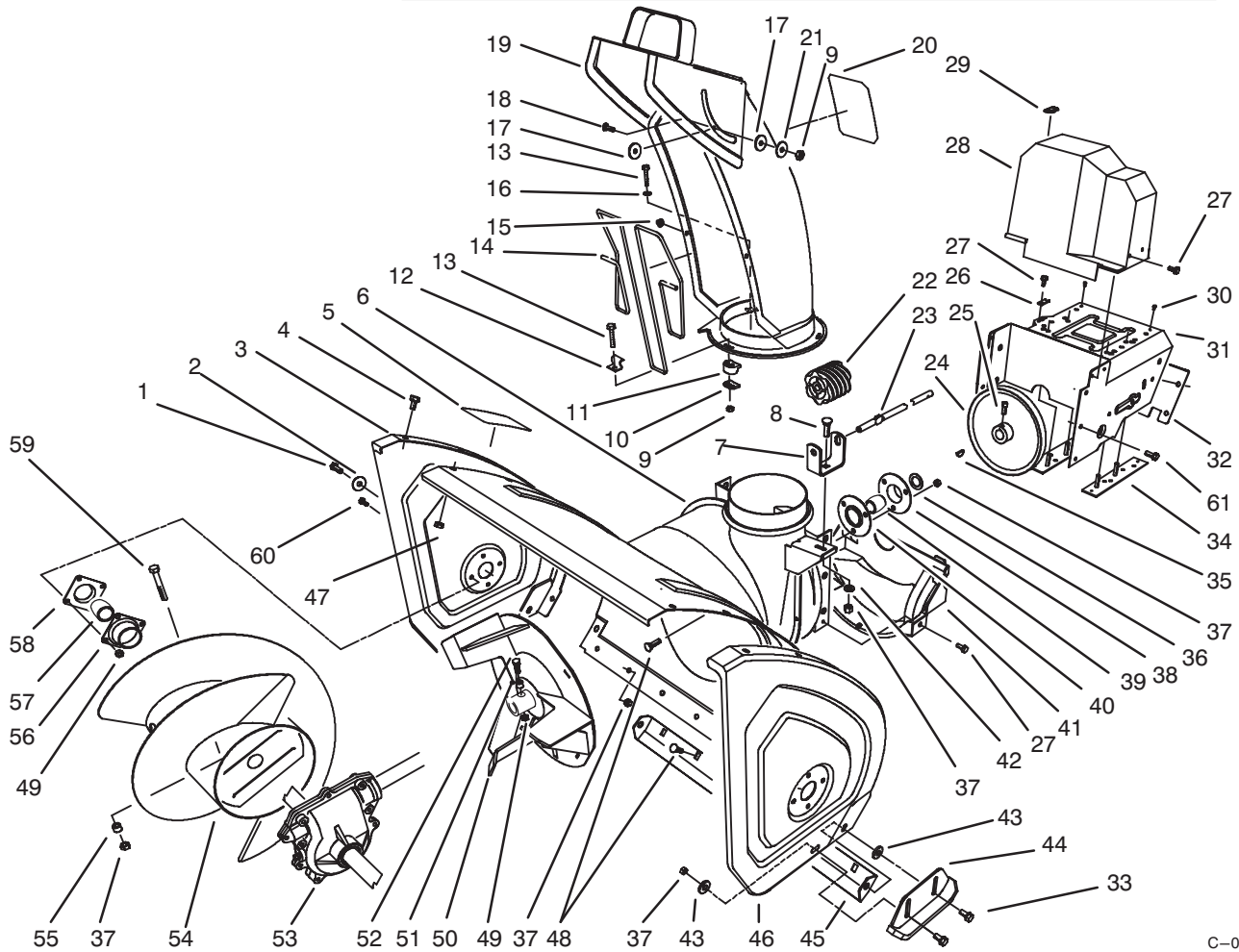

MODEL NO. 38556-690001 & UP

PARTS CATALOG

1028 SNOWTHROWER



C-0045

HOUSING & CHUTE ASSEMBLY

Ref. No.	Part No.	Description	No. Used
1	323-6	Screw - Hex. Hd.	2
2	3-0750	Washer - Retaining	2
3	66-7821	Plate - Side R.H.	1
4	3234-28	Screw - Hex. Flange Hd.	12
5	53-7670	Decal - Danger Auger	1
6	62-0721	Housing - 28"	1
7	63-2180	Bracket - Gear	1
8	3230-2	Bolt - Carriage	1
9	3296-2	Nut - Lock	4
10	63-2670	Plate - Chute Retainer	3
11	62-1430	Retainer - Chute	3
12	63-3130	Clip - Chute Guard	1
13	3274-13	Screw - Machine	3
14	63-3020	Guard - Chute	1
15	3290-326	Nut - Push	2
16	3256-14	Washer - Flat	3

Ref. No.	Part No.	Description	No. Used
17	63-2900	Washer - Plastic	2
18	32122-32	Screw	1
19	62-0840	Chute Assembly	1
20	63-3740	Decal - Danger Chute	1
21	3256-61	Washer - Flat	1
22	62-0820	Gear - Worm	1
23	62-1720	Rod - Chute Gear	1
24	62-1300	Pulley - Impeller	1
25	3242-4	Screw - Set Sq. Hd.	2
26	63-2300	Retainer - Cable	1
27	32144-4	Screw - Hex. Flange Hd.	6
28	63-2080	Cover - Belt (Upper)	1
29	63-3290	Cover - Cable	1
30	3269-23	Rivet	4
31	66-6980	Frame - Engine	1
32	62-1440	Cover - Engine Frame	1

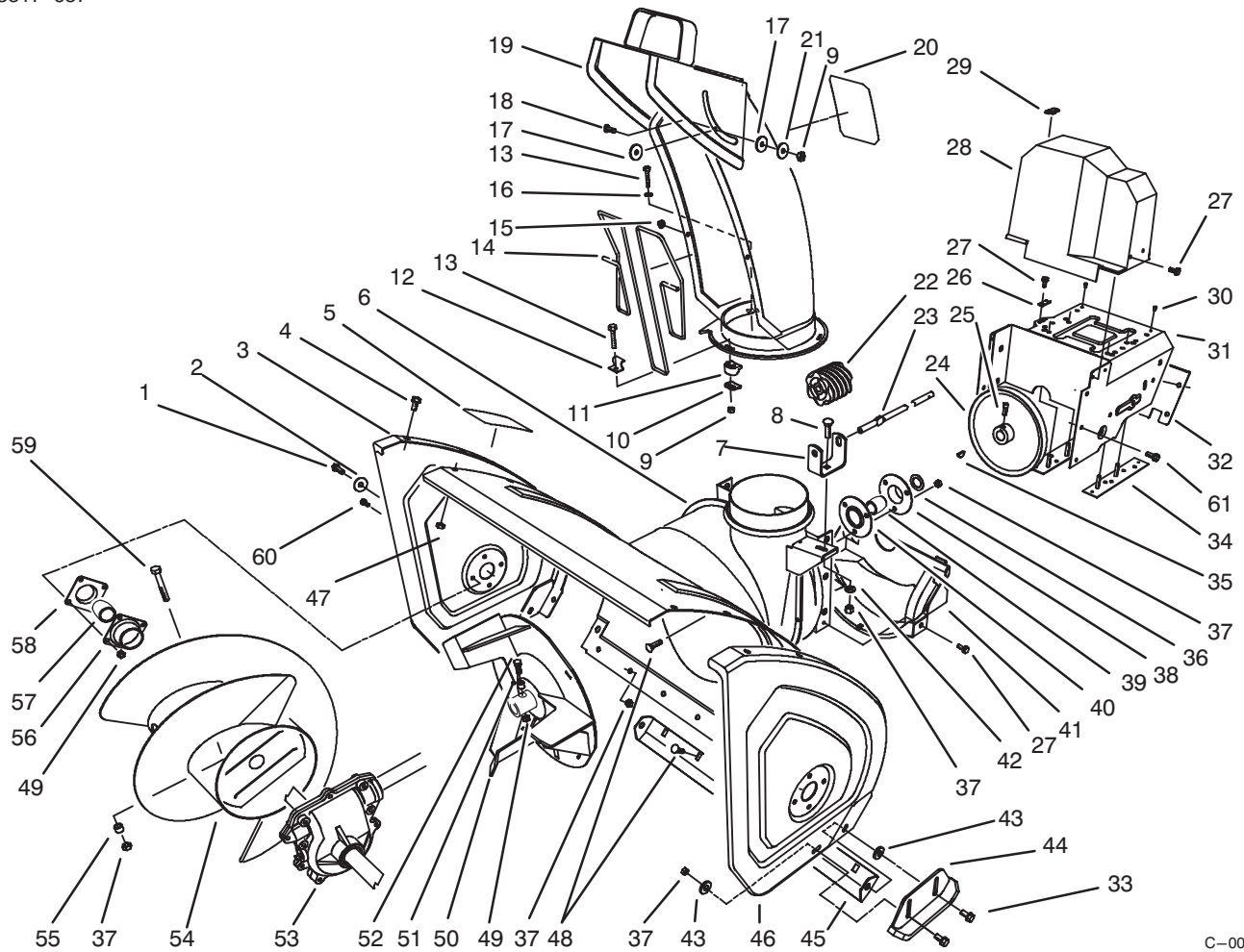

C-0045

HOUSING ASSEMBLY (Continued)

Ref. No.	Part No.	Description	No. Used
33	3234-5	Screw - Hex. Washer Hd.	4
34	68-4110	Plate - Engine Stud L.H.	1
*	68-4100	Plate - Engine Stud R.H.	1
35	3257-23	Key - Woodruff	1
36	252-80	Washer - Thrust	1
37	3296-29	Nut - Lock	12
38		Flange - Bearing (Rear)	1
39	63-3450	Bearing - Impeller	1
40		Flange - Bearing (Front)	1
41	68-8410	Cover - Belt (Lower)	1
42	3256-23	Washer - Flat	1
43	52-2861	Washer	4
44	74-1440	Skid Assembly	2
45	66-7761	Blade - Scraper	1
46	66-7831	Plate - Side L.H.	1
47	3296-47	Nut - Lock	12
48	3230-23	Screw - Carriage	10

Ref. No.	Part No.	Description	No. Used
49	3296-42	Nut - Lock	10
50	66-7920	Impeller	1
51	66-8010	Spacer	2
52	321-44	Screw - Hex. Hd.	2
53	74-1561	Auger Gearbox Assembly	1
54	68-7451	Auger - R.H.	1
*	68-7461	Auger - L.H.	1
55	25-5090	Spacer - Auger Hub	2
56	20-0990	Flange - Bearing (Inner)	2
57	20-0980	Bearing - Auger	2
58	20-1000	Flange - Bearing (Outer)	2
59	322-12	Bolt - Auger	2
60	321-3	Screw - Hex. Hd.	8
61	3234-3	Screw	6
*	12-8789	Impeller Bearing Assembly (Incl. Ref. #38-40)	1
*	12-8949	Loose Parts	1

*Not Illustrated

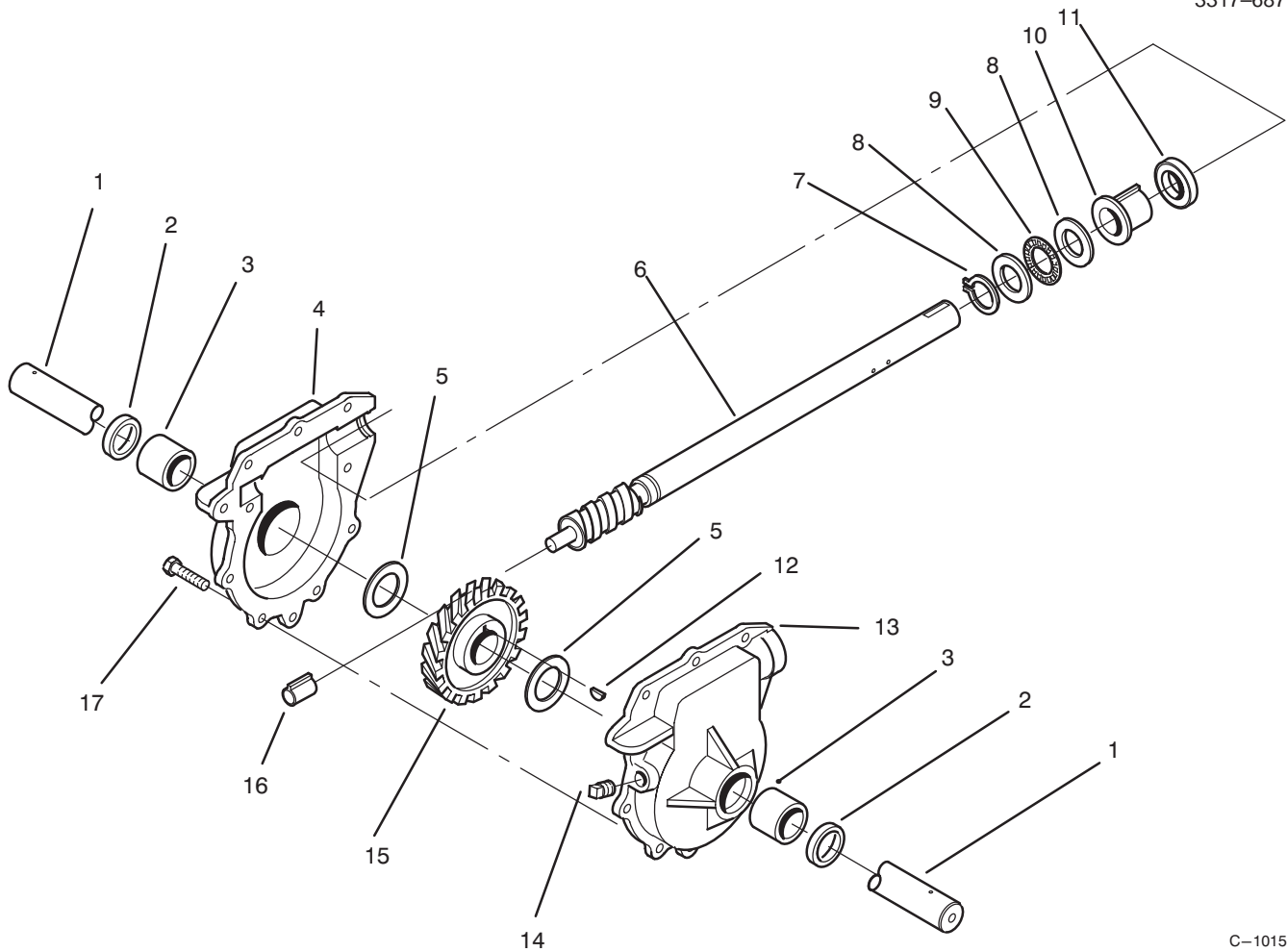

C-1015

28" AUGER GEARCASE ASSEMBLY NO. 74-1561

Ref. No.	Part No.	Description	No. Used
1	62-1531	Shaft - Auger (28")	1
2	7-0045	Seal - Oil	2
3	256-237	Bushing - Sleeve	2
4	74-1580	Gearcase Assembly - R.H. (Incl. Ref. # 2-3)	1
5	252-71	Bearing - Thrust	2
6	66-7811	Shaft - Impeller	1
7	32151-33	Ring - Snap	1
8	252-78	Washer - Thrust	2
9	252-76	Bearing - Thrust	1

Ref. No.	Part No.	Description	No. Used
10	37-6560	Bushing - Input	1
11	253-149	Seal - Input	1
12	3257-10	Key - Woodruff	1
13	74-1570	Gearcase Assembly - L.H. (Incl. Ref. # 2-3)	1
14	281-1	Plug - Pipe Sq. Hd.	1
15	62-0120	Gear - Helical	1
16	62-1150	Bushing - Worm	1
17	32144-110	Screw - Hex. Washer Hd.	9
*	505-129	Sealant - 100g Tube	1

*Not Illustrated

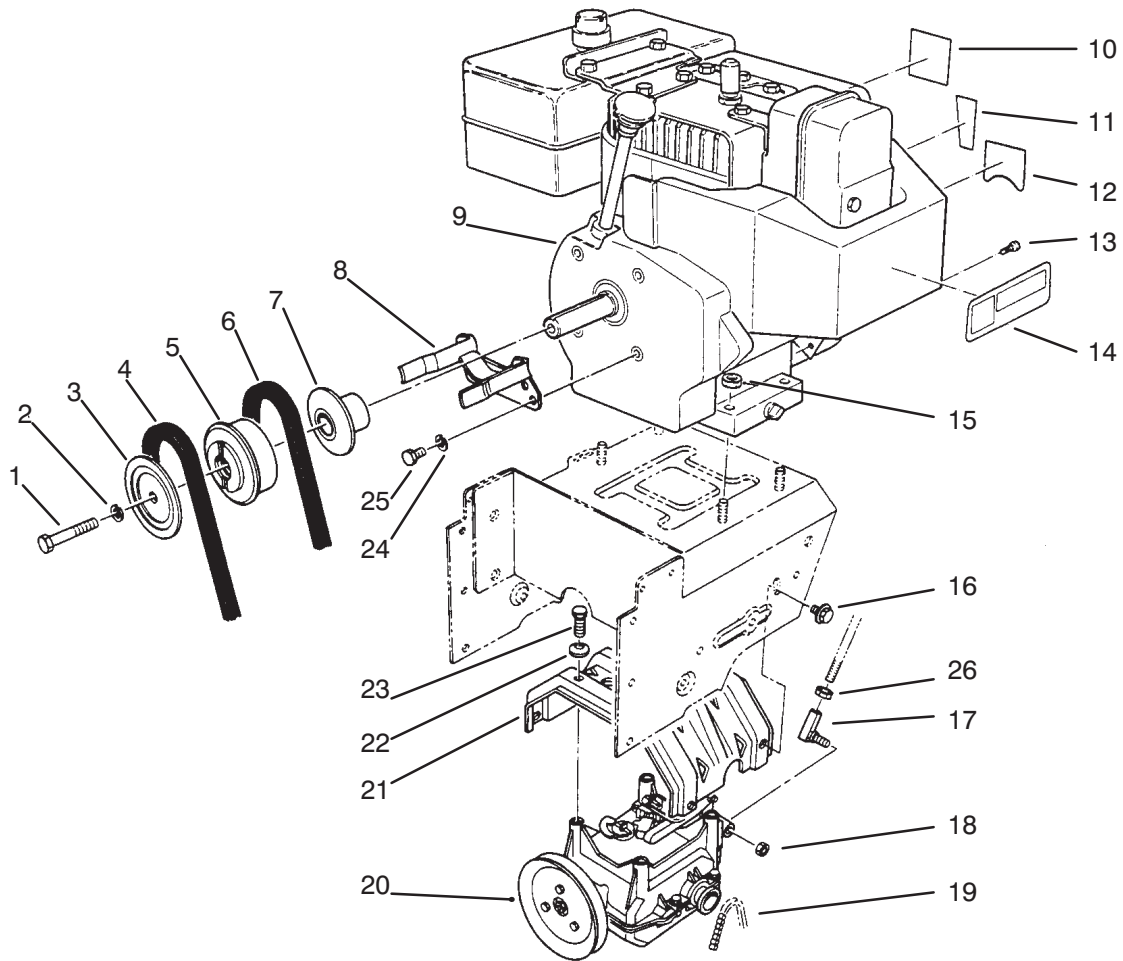

C-0048

ENGINE ASSEMBLY

Ref. No.	Part No.	Description	No. Used
1	3212-8	Screw - Hex. Hd.	1
2	3253-6	Washer - Lock	1
3	62-0940	Sheave Half - Impeller	1
4	63-2962	Belt - Impeller	1
5	62-0930	Hub - Sheave	1
6	63-2951	Belt - Traction	1
7	62-0920	Sheave Half - Traction	1
8	68-7510	Guide - Belt	1
†9		Engine - Tecumseh Model HMSK100-159227U	1
10	62-5760	Decal - Primer	1
11	63-3190	Decal - Throttle	1
12	63-2400	Decal - Choke	1
13	32144-4	Screw	1

Ref. No.	Part No.	Description	No. Used
14	94-2560	Decal - Hot Surface	1
15	32128-20	Nut - Lock	4
16	3234-7	Screw - Hex. Flange Hd.	4
17	63-2640	Joint - Ball	1
18	3296-39	Nut - Lock	1
19	63-2930	Chain - Drive	1
20	66-8030	Transmission Assembly	1
21	63-2990	Frame - Transmission	1
22	3290-461	Washer - Belleville	4
23	11-0590	Screw - Hex. Hd.	4
24	3253-4	Washer - Lock	2
25	3210-1	Screw - Hex. Hd.	2
26	3220-3	Nut - Jam	1

†Obtain from your local Tecumseh Dealer.

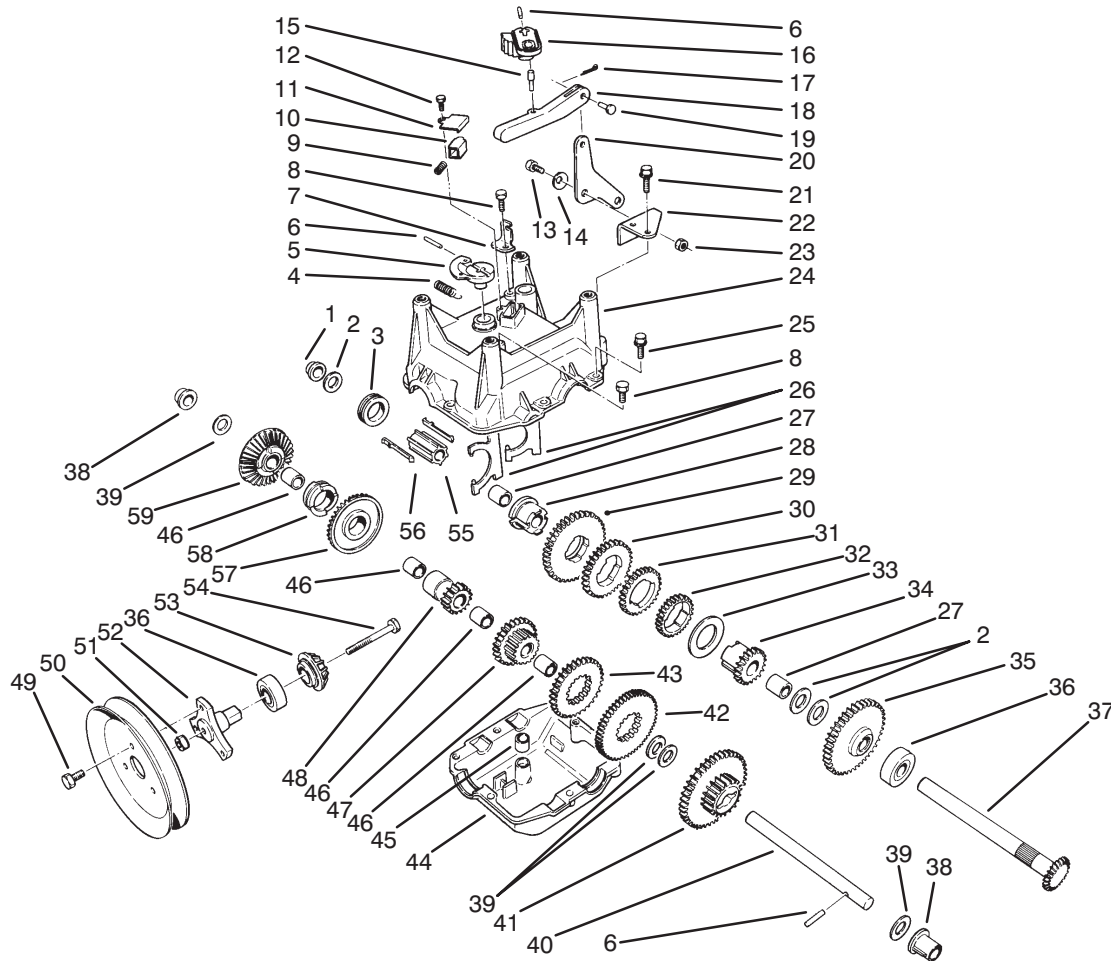

C-0052

TRANSMISSION ASSEMBLY NO. 66-8030

Ref. No.	Part No.	Description	No. Used
1	62-1180	Bushing - Output (Flange)	1
2	252-59	Washer - Thrust	3
3	62-0430	Collar - Shift (Speed)	1
4	63-2920	Spring - Extension (F/R Return)	1
5	62-0880	Lever - Direction Shift	1
6	32121-106	Pin - Coil	3
7	62-1740	Bracket - Cable	1
8	32144-4	Screw - Self Tapping	2
9	63-2890	Spring - Compression (Detent)	1
10	62-1020	Button - Detent	1
11	62-1690	Cover - Detent	1
12	32104-71	Screw - Pan Hd.	1
13	63-3410	Bolt - Shoulder	1
14	3290-477	Washer - Curved	1
15	63-2190	Pin - Gearshift Link	1
16	62-0870	Lever - Gear Shift	1
17	3272-1	Pin - Cotter	1
18	62-0860	Link - Gearshift	1
19	283-3	Pin - Clevis	1
20	63-2600	Bellcrank	1
21	32104-95	Screw - Hex. Washer Hd.	2

Ref. No.	Part No.	Description	No. Used
22	62-1190	Bracket - Bellcrank	1
23	3296-42	Nut - Lock	1
24	62-0490	Gear Case - Upper	1
25	32144-86	Screw - Hex Washer Hd.	6
26	62-1040	Yoke-Shift	2
27	62-1350	Bushing - Output	2
28	62-0320	Sleeve	1
29	62-0240	Gear - 45T	1
30	62-0220	Gear - 34T	1
31	62-0200	Gear - 27T	1
32	62-0250	Gear - 29T	1
33	63-2280	Washer - Thrust	1
34	62-0340	Sleeve - Gear 19T	1
35	62-0370	Gear - 41T	1
36	38-7820	Bearing - Ball	2
37	62-1080	Shaft - Output	1
38	62-1170	Bushing - Flange	2
39	257-10	Washer - Thrust	4
40	62-0330	Shaft - Intermediate	1
41	62-0360	Gear - Compound 19T/41T	1
42	62-0260	Gear - 51T	1
43	62-0210	Gear - 33T	1
44	62-0480	Gear Case - Lower	1

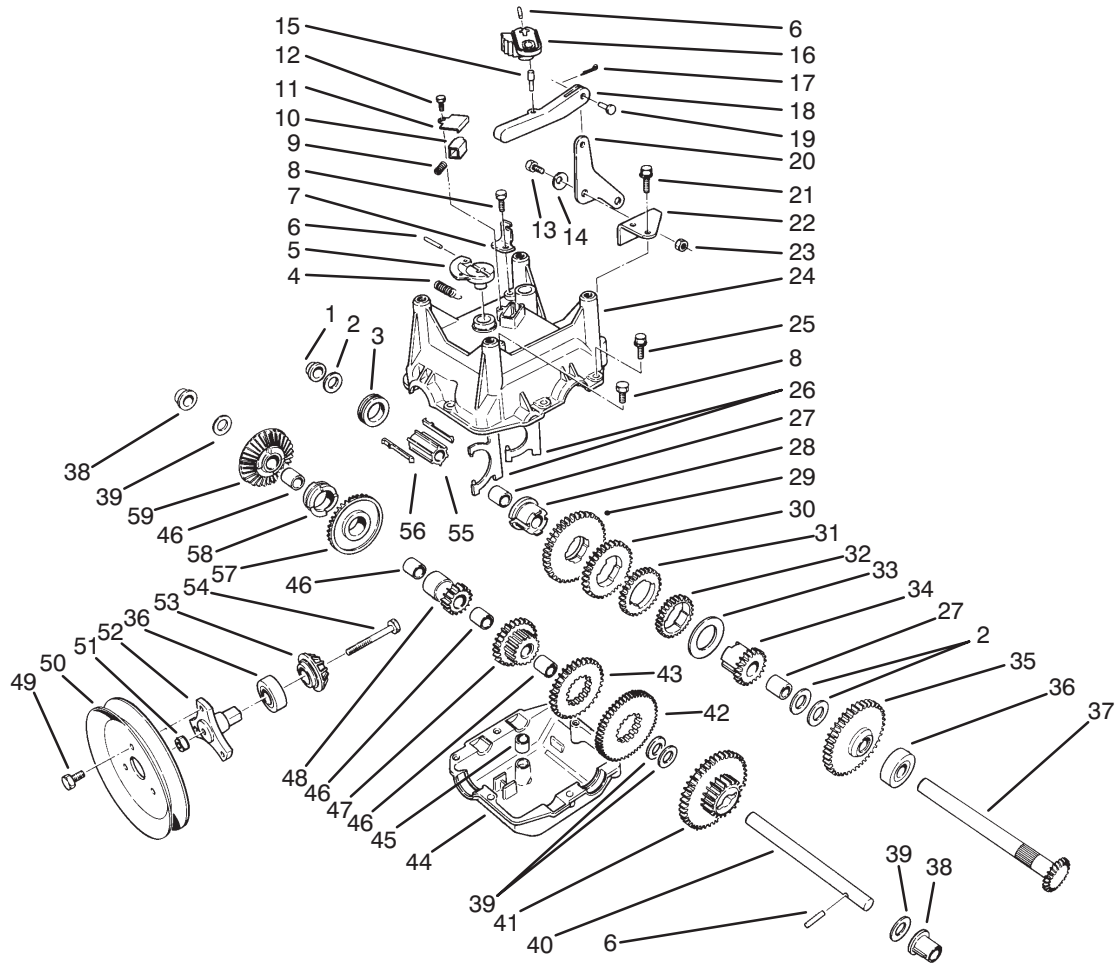

C-0052

TRANSMISSION ASSEMBLY NO. 66-8030 (Continued)

Ref. No.	Part No.	Description	No. Used
45	29-9570	Bushing - Yoke	1
46	62-1160	Bushing - Intermediate	4
47	68-4310	Gear - 26T	1
48	62-0500	Gear - 15T	1
49	12-3270	Screw	3
50	62-1310	Pulley - Traction	1
51	32128-32	Nut - Flange Lock	1
52	62-0380	Hub - Pulley	1
53	62-0350	Pinion - Bevel 19T	1

Ref. No.	Part No.	Description	No. Used
54	321-15	Screw - Hex. Hd.	1
55	68-4320	Sleeve - Shift	1
56	62-0310	Key - Shift	2
57	67-5870	Gear - Bevel 36T	1
58	67-5880	Collar - Shift	1
59	13-3559	Gear - Bevel Reverse 36T (Incl. Ref. #46)	1
*	505-101	Grease - 14.5 oz. Cartridge	1

*Not Illustrated

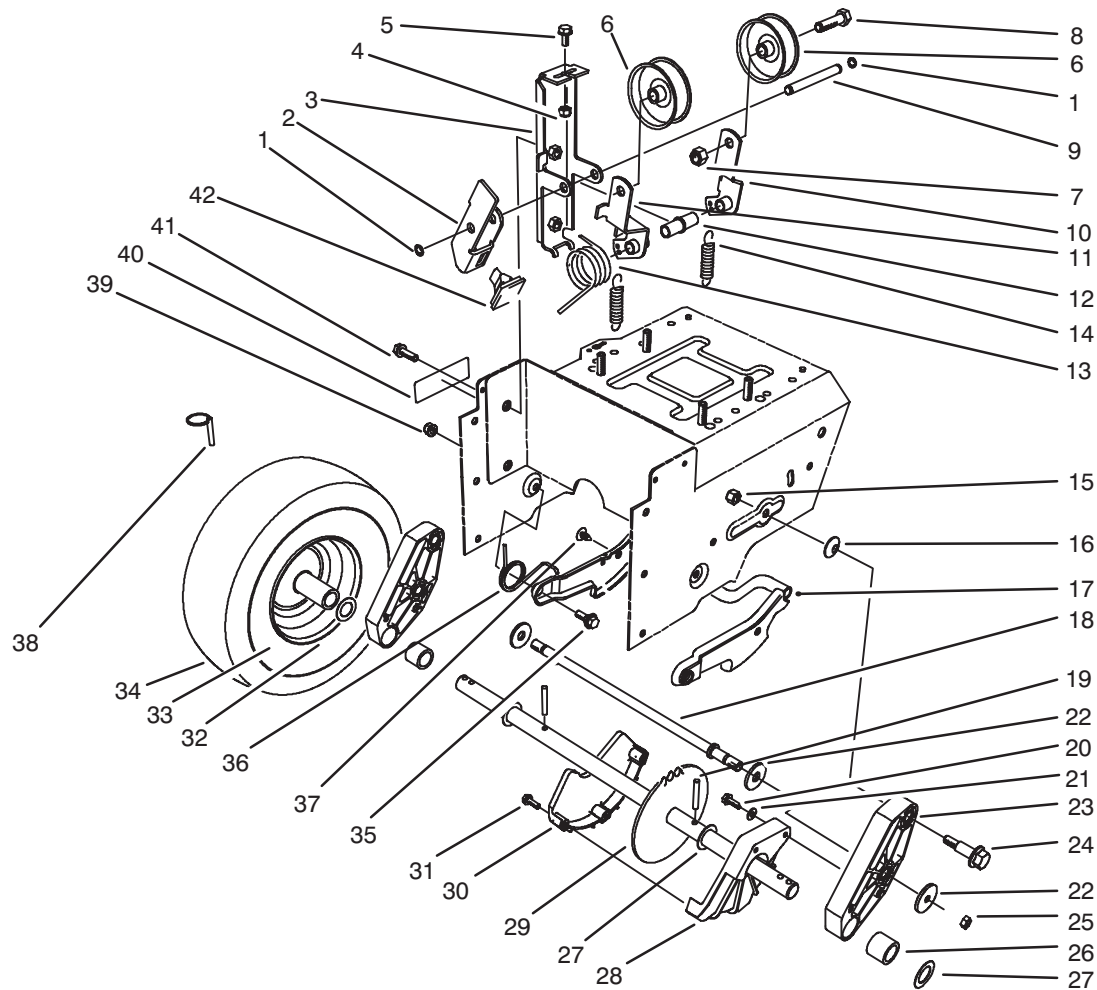

C-0053

TRACTION DRIVE ASSEMBLY

Ref. No.	Part No.	Description	No. Used	Ref. No.	Part No.	Description	No. Used
1	32120-46	Ring - Retaining	2	23	66-7740	Pivot Arm Assembly (Incl. Ref. # 26)	2
2	63-2820	Arm - Brake	1	24	62-1330	Bolt - Shoulder	2
3	63-2850	Bracket - Idler Arm	1	25	3296-23	Nut - Lock	2
4	3296-42	Nut - Lock	1	26	63-2250	Bushing - Axle	2
5	3234-13	Screw - Hex. Hd.	1	27	252-80	Washer - Thrust	4
6	3-4244	Pulley - Idler	2	28	62-1010	Guard - Chain L.H.	1
7	3296-59	Nut - Lock	2	29	63-2112	Axle Assembly	1
8	323-7	Screw - Hex. Hd.	2	30	62-1000	Guard - Chain R.H.	1
9	62-0970	Pin - Idler	1	31	32104-121	Screw - Hex. Flange Hd.	3
10	93-8045	Arm - Traction Idler	1	32	241-127	Rim - Wheel	2
11	93-8046	Arm - Impeller Idler	1	33	232-48	Tube - Inner	2
12	3256-38	Bushing - Idler	1	34	231-123	Tire	2
13	63-2881	Spring - Torsion	1	35	5-2490	Bolt - Shoulder	2
14	63-2870	Spring - Extension	2	36	63-2740	Spring - Torsion	1
15	3296-39	Nut - Lock	2	37	3290-476	Fastener - Panel	1
16	3290-461	Washer - Belleville	2	38	3290-243	Pin - Klik	2
17	62-0470	Latch - Arm	1	39	3296-47	Nut - Lock	2
18	66-7720	Rod - Latch	1	40	66-6860	Decal - Warning	1
19	32121-9	Pin - Roll	2	41	3234-7	Screw - Hex. Flange Hd.	2
20	32144-4	Screw - Hex. Flange Hd.	2	42	66-8060	Pad - Brake	1
21	3256-1	Washer - Flat	2				
22	63-3340	Washer	4				

*Not Illustrated

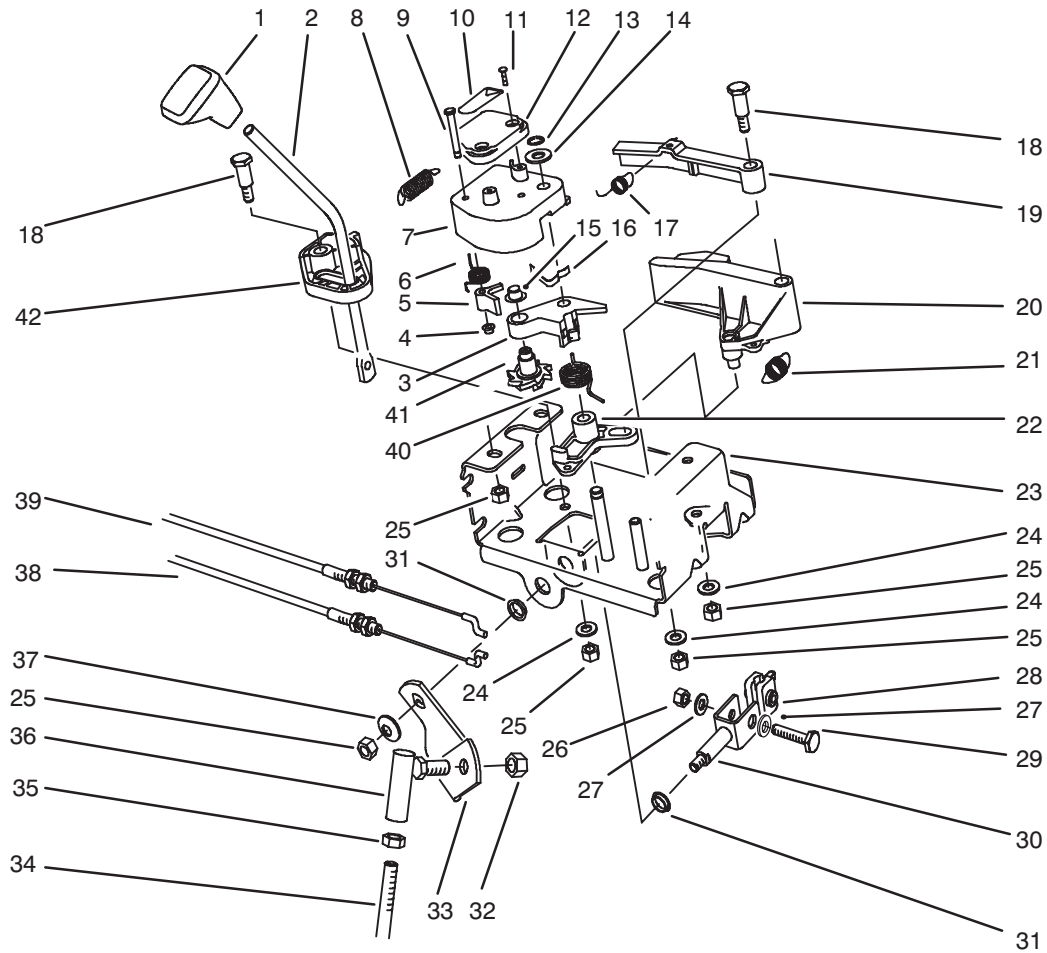

C-0054

TRACTION LINKAGE ASSEMBLY

Ref. No.	Part No.	Description	No. Used
1	62-1290	Knob - Shift	1
2	67-9240	Rod - Shift (Upper)	1
3	62-1110	Lever - Index Wheel	1
4	3290-422	Nut - Push	1
5	62-0180	Tang - Index	1
6	62-1650	Spring - Torsion	1
7	62-1100	Lever - Latch	1
8	63-2220	Spring - Extension	1
9	63-2610	Pin - Tang	1
10	63-2480	Decal - #2	1
11	32104-118	Screw - Pan Hd.	2
12	62-1140	Cover - Latch	1
13	32120-46	Ring - Retaining	1
14	257-9	Washer - Thrust	1
15	3290-320	Nut - Push	1
16	62-1710	Spring - Flat	1
17	63-2240	Spring - Extension	1
18	63-2650	Screw - Shoulder	2
19	62-1700	Lever - Lockout	1
20	62-1130	Lever - Reverse	1
21	63-2230	Spring - Extension	1

Ref. No.	Part No.	Description	No. Used
22	62-1120	Lever - Reverse	1
23	63-2150	Frame - Control	1
24	3256-23	Washer - Flat	3
25	3296-29	Nut - Lock	7
26	3296-42	Nut - Lock	1
27	3256-1	Washer - Flat	2
28	67-9250	Retainer - Shift Rod	1
29	321-9	Screw - Hex. Hd.	1
30	66-7730	Clevis	1
31	256-296	Bushing - Nylon	2
32	3296-39	Nut - Lock	1
33	63-2630	Bracket - Shift	1
34	63-2830	Rod - Shift (Lower)	1
35	3220-3	Nut - Jam	1
36	63-2640	Joint - Ball	1
37	3290-456	Washer - Belleville	1
38	63-2210	Cable - Gearbox	1
39	63-2200	Cable - Latch	1
40	63-2270	Spring - Torsion	1
41	62-0170	Wheel - Index	1
42	62-1470	Base - Lockout	1

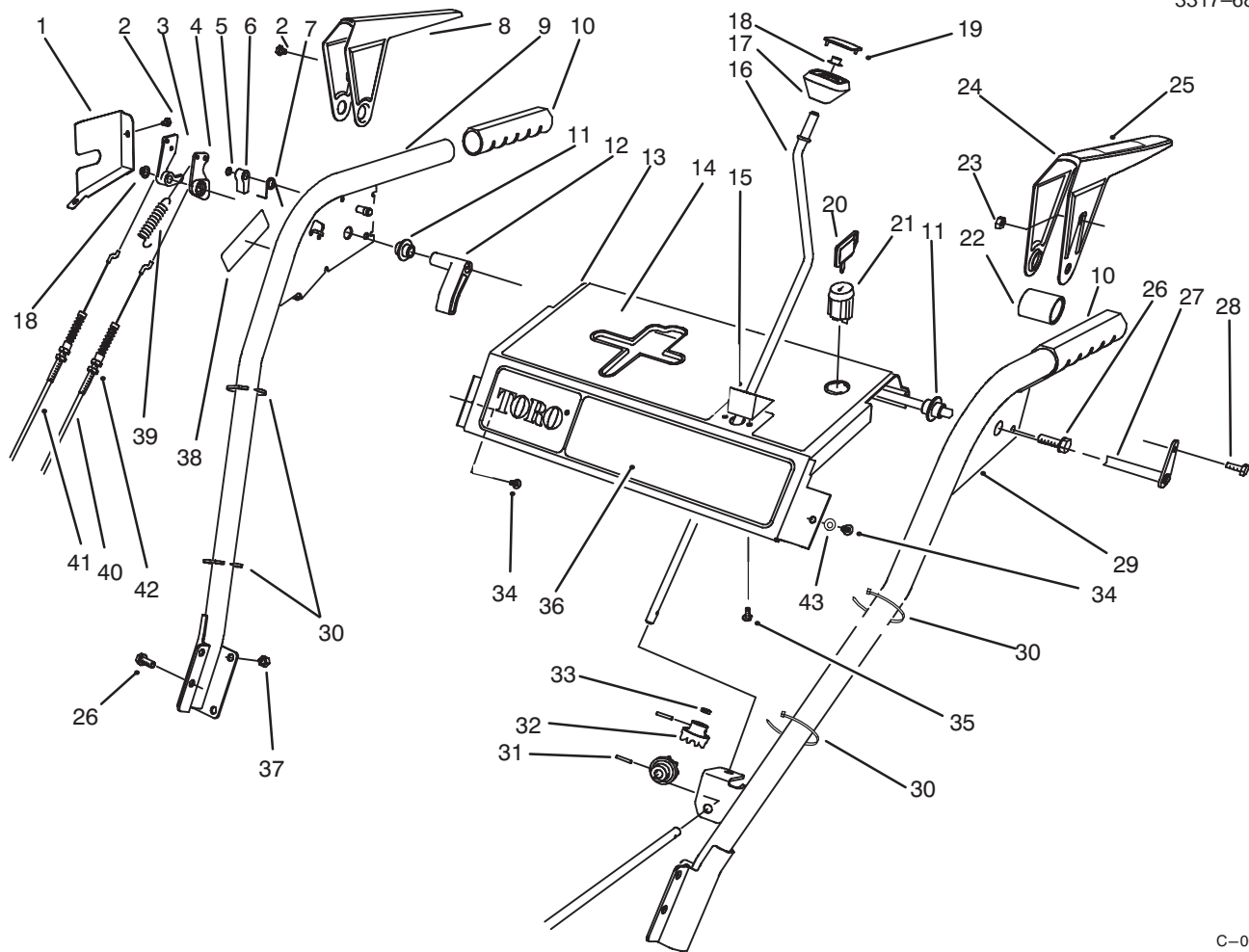

C-0055A

HANDLE ASSEMBLY

Ref. No.	Part No.	Description	No. Used
1	63-2170	Cover - Lever Lock	1
2	2210-250	Screw	3
3	62-0300	Tang - Locking	1
4	62-0290	Cam - Release	1
5	32151-66	Ring - Retaining	1
6	62-0280	Latch - Lock	1
7	63-2910	Spring - Torsion	1
8	62-1050	Lever - Impeller	1
9	62-1381	Handle - R.H.	1
10	66-7850	Handlegrip	2
11	62-1070	Bushing - Lever	2
12	62-1640	Lever - Trip	1
13	66-8100	Panel - Control	1
14	66-6850	Decal - Panel Top	1
15	62-1490	Plate - Guide	1
16	63-2160	Rod - Chute Crank	1
17	62-1320	Knob - Chute Control	1
18	3290-320	Nut - Push	2
19	62-1520	Cover - Knob	1
20	63-8360	Key - Switch	1
21	40-5940	Switch - On/Off	1
22	63-3380	Spacer - Traction Lever	1

Ref. No.	Part No.	Description	No. Used
23	3296-2	Nut - Lock	1
24	62-1060	Lever - Traction	1
25	63-3050	Decal - Lever	1
26	3234-7	Screw - Hex. Flange Hd.	6
27	63-2030	Rod - Cross	1
28	3290-359	Screw	1
29	66-8091	Handle - L.H.	1
30	3290-378	Tie - Cable	4
31	32121-50	Pin - Roll	2
32	62-1460	Gear - Universal	2
33	62-1230	Washer - Rubber	1
34	32104-76	Screw - Self Tapping	2
35	32104-118	Screw - Pan Hd.	2
36	88-0590	Decal - Panel Front	1
37	3296-47	Nut - Lock	4
38	66-6860	Decal - Warning	1
39	88-0810	Spring - Extension	1
40	63-2710	Cable - Traction	1
41	63-2700	Cable - Impeller	1
42	3296-42	Nut	4
43	3256-14	Washer - Flat	2
*	63-3420	Harness - Wire	1

*Not Illustrated

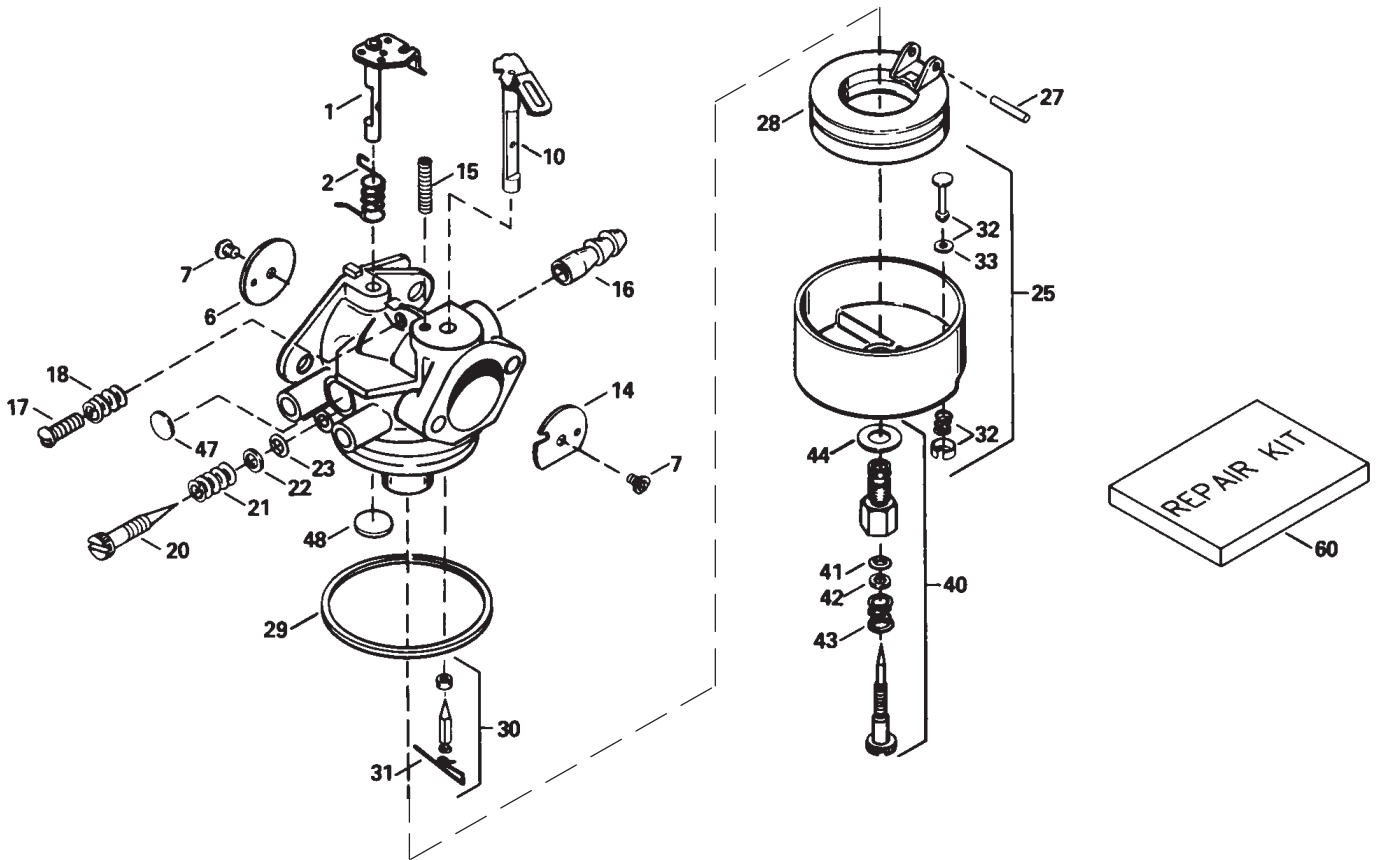

C-1704

CARBURETOR NO. 632370A

Ref. No.	Part No.	Description	No. Used
1	631776A	Throttle Shaft & Lever Assy.	1
2	631970	Throttle Return Spring	1
6	631778	Throttle Shutter	1
7	650506	Screw – Throttle & Choke Shutter	4
10	632112	Choke Shaft & Lever Assy	1
14	632174	Choke Shutter	1
15	630735	Choke Positioning Spring	1
16	632164	Fitting – Fuel	1
17	650417	Screw – Idle Speed	1
18	630766	Spring – Tension	1
20	632281	Screw – Idle Mixture	1
21	630766	Spring – Idle Mixture Screw	1
22	630739	Washer – Idle Screw	1
23	630740	O–Ring – Idle Screw	1
25	631951	Float Bowl (Incl. Ref.# 32 & 33)	1
27	631024	Shaft – Float	1
28	632019	Float	1
29	631028	O–Ring, Float Bowl to Body	1

Ref. No.	Part No.	Description	No. Used
30	631021	Inlet Needle, Seat & Spring Clip (Incl Ref.# 31)	1
31	631022	Spring Clip	1
32	27136A	Bowl Drain Assy. (Incl Ref.# 33)	1
33	27554	Drain Plunger – Gasket	1
40	632239	High Speed Mixture Screw Assembly	1
41	630740	O–Ring – High Speed Mixture Screw	1
42	630739	Washer, High Speed Mixture Screw	1
43	630738	Spring – Tension	1
44	27110	Washer – Bowl Nut	1
47	630748	Welch Plug – Idle Mixing	1
48	631027	Welch Plug – Vent	1
60	632347	Repair Kit (Incl. Ref. # 23, 27, 29–30, 41, 44, & 47–48)	1

TECUMSEH ENGINE MODEL HMSK100-159227U

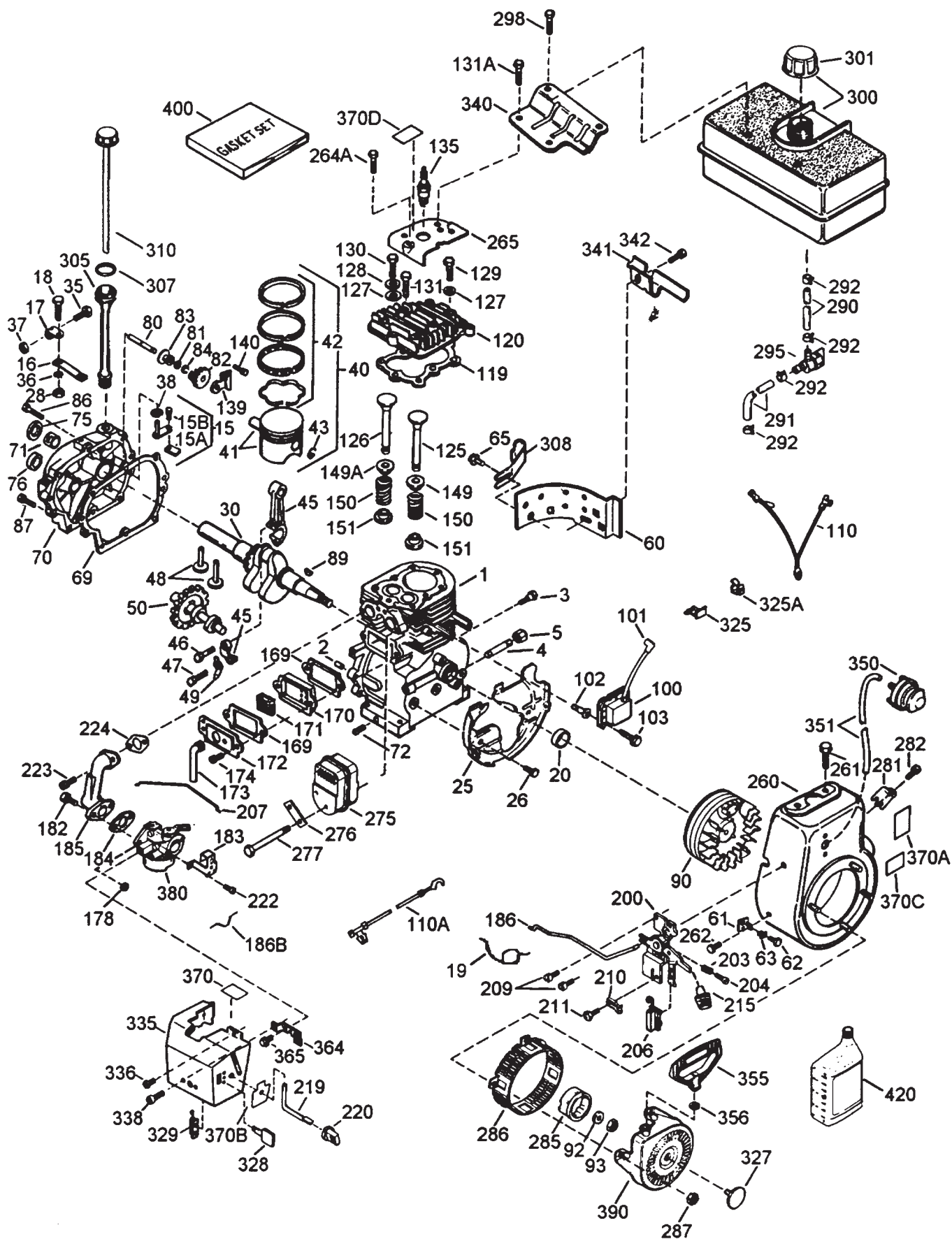

TECUMSEH ENGINE MODEL HMSK100-159227U

Ref. No.	Part No.	Description	No. Used	Ref. No.	Part No.	Description	No. Used
1	35371	Cylinder (Incl. ref.#2 & 20)	1	63	28545	Grommet - Plastic	1
2	27652	Pin - Dowel	2	65	650128	Screw - Hex Head Sems	1
3	650820	Screw - Hex Hd. Shoulder	2	*69	35262A	Gasket - Cylinder Cover	1
4	XXXXX	Nipple - Pipe	1	70	35376	Cover Assembly, Cylinder (Incl. ref.#71, 75 & 80)	1
5	30969	Cap - Oil Drain	1	71	35377	Bushing - Cylinder Cover	1
15	30699C	Rod Assembly - Governor (Incl. ref.#15A & 15B)	1	75	35319	Seal - Oil	1
15A	30700	Yoke - Governor	1	80	31845	Shaft - Governor	1
15B	650494	Screw - Fil. Hd. Sems	1	81	30590A	Washer - Flat	1
16	33454	Lever - Governor	1	82	35378	Gear - Governor (Incl. ref.#81)	1
17	29916	Clamp - Governor Lever	1	83	30588A	Spool - Governor	1
18	650548	Screw - Hex Washer Hd.	1	84	29193	Ring - Retaining	1
19	34663	Spring - Speed Control	1	86	650833	Screw, Hex Washer Powerlok	7
20	35319	Seal - Oil	1	87	650832	Screw, Hex Washer Powerlok	1
25	36460	Baffle - Blower Housing	1	89	32589	Key - Flywheel	1
26	650561	Screw - Hex Washer Hd.	2	90	611093	Flywheel (w/Ring Gear)	1
28	30322	Locknut	1	92	650880	Washer - Lock	1
30	35571A	Crankshaft	1	93	650881	Nut - Flywheel	1
35	29826	Screw - Hex Washer Hd.	1	100	35135	Solid State Assembly	1
36	29918	Washer - Ext. Tooth Lock	1	101	610118	Cover - Spark Plug	1
37	29216	Nut & Lockwasher - Keps	1	102	650872	Stud - Solid State Mounting	2
38	29642	Ring - Retaining	1	103	651007	Screw, Torx Hex Washer Sems	1
40	35776	Piston, Pin & Ring Assy. Std. (Includes ref.#41, 42 & 43)	1	110	35253	Wire - Ground	1
	35777	Piston, Pin & Ring Assy. .010 oversize (Includes ref.#41, 42 & 43)	1	*119	36451	Gasket - Cylinder Head	1
	35778	Piston, Pin & Ring Assy. .020 oversize (Includes ref.#41, 42 & 43)	1	120	36449	Head - Cylinder	1
41	35773	Piston & Pin Assembly Standard (Includes ref.#43)	1	125	27878A	Valve - Exhaust, Standard (Incl. ref.# 151)	1
	35774	Piston & Pin Assembly .010 oversize (Incl. ref.#43)	1		27880A	Valve - Exhaust 1/32" oversize (Incl. ref.# 151)	1
	35775	Piston & Pin Assembly .020 oversize (Incl. ref.#43)	1	126	34035	Valve - Intake, Standard (Incl. ref.# 151)	1
42	35779	Ring Set, Piston (Standard)	1		34036	Valve - Intake 1/32" oversize (Incl. ref.# 151)	1
	35780	Ring Set, Piston (.010 oversize)	1	127	650691	Washer - Flat	5
	35781	Ring Set, Piston (.020 oversize)	1	128	650690	Washer - Belleville	3
43	35772	Retaining Ring, Piston Pin	2	129	650727	Screw - Special	2
45	35681	Rod Assembly - Connecting (Incl. ref.#46, 47 & 49)	1	130	6021A	Screw - Hex Flange Hd.	4
46	650908	Bolt, Connecting Rod	1	131	650694A	Screw - Hex Flange Hd.	3
47	650882	Bolt, Connecting Rod	1	131A	650713	Screw - Hex Hd.	2
48	34034	Lifter - Valve	2	135	35395	Spark Plug (RJ-19LM Resistor)	1
49	35374	Dipper - Oil	1	139	33369	Bracket - Governor Gear	1
50	35375	Camshaft (Mechanical Compression Release)	1	140	650836	Screw - Hex Washer Hd.	2
60	33273A	Extension - Blower Housing	1	149	27882	Cap - Upper Valve Spring	1
61	34126	Bracket - Grommet Mounting	1	149A	35862	Seal Assy. - Intake Valve	1
62	650760	Screw - Pan Hd. Taptite	1	150	27881	Spring - Valve	2
				151	32581	Cap - Lower Valve Spring	2
				*169	27896A	Gasket - Breather	2
				170	28423	Body - Breather	1
				171	28424	Element - Breather	1
				172	28425	Cover - Breather	1

* Included in Gasket Set 36452 (Ref.# 400).

TECUMSEH ENGINE MODEL HMSK100-159227U

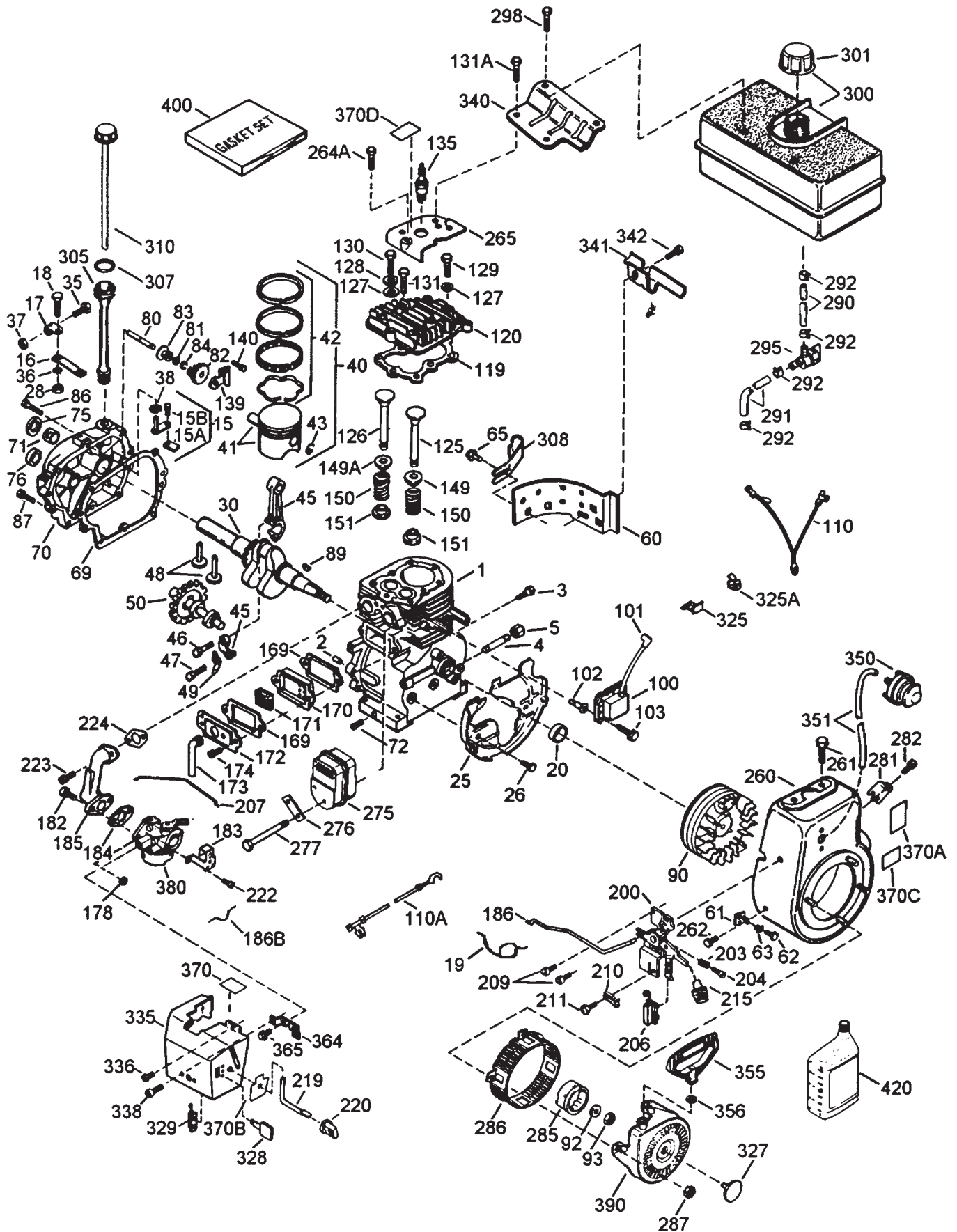

TECUMSEH ENGINE MODEL HMSK100-159227U (Continued)

Ref. No.	Part No.	Description	No. Used	Ref. No.	Part No.	Description	No. Used
173	35350	Tube – Breather	1	290	29774	Line – Fuel (8-1/4")	1
174	650128	Screw – Hex Hd. Sems	2	291	30705	Line – Fuel (16")	1
178	29752	Nut & Lockwasher	2	292	26460	Clamp – Fuel Line	4
182	30088A	Screw – Fil. Hd. Sems	2	295	35857	Valve – Fuel Shut-Off	1
183	34587	Bracket – Choke	1	298	650665	Screw – Hex Washer Hd.	2
*184	33263	Gasket – Intake Pipe	1	300	34156A	Tank Assembly, Fuel (Incl. Ref.# 292 & 301)	1
185	33877	Pipe – Intake	1	301	36246	Cap – Fuel Tank	1
186	34667	Link – Governor	1	305	35554	Tube – Oil Fill	1
186B	36652	Spring – Choke	1	306	35499	O-Ring	1
200	34677	Bracket Assy. – Control (Incl. Ref.# 203, 204 & 206)	1	308	35540	Clip – Fill Tube	1
203	31342	Spring – Compression	1	310	36205	Dipstick – Oil	1
204	650549	Screw – Fil Hd.	1	314	650873	Screw – Hex Hd. Sems	1
206	610973	Terminal Assembly	1	316	611111	Coil Assy., Alternator (18 Watt)	1
207	33878	Link – Governor to Throttle	1	323	611118	Terminal	1
209	650821	Screw – Hex Washer Hd.	2	325	29443	Clip – Spring	1
215	35440	Knob – Control	1	327	35392	Plug – Starter	1
219	34586	Rod – Choke	1	335	35057A	Cover – Carburetor	1
220	35438	Knob – Choke	1	336	650765	Screw – Hex Washer Hd.	1
222	28820	Screw – Fil. Hd. Sems	2	338	28942	Screw – Hex Washer Sems	2
223	650378	Screw – Torx Fil Hd. Sems	2	340	34155	Bracket – Fuel Tank	1
*224	27915A	Gasket – Carburetor	1	341	34154	Plate – Fuel Tank Mounting	1
260	35447A	Housing – Blower	1	342	650561	Screw – Hex Washer Hd.	1
261	650788	Screw – Hex Hd.	2	350	570682	Primer Assembly	1
262	29747B	Screw – Hex Hd. Sems	2	351	32180C	Line – Primer	1
264A	650802	Cover – Cylinder Head	1	355	590574	Starter Handle – Mitten Grip	1
265	33272B	Cover – Cylinder Head	1	364	33377	Bracket – Carburetor Cover Mounting	1
275	35056	Muffler	1	365	650767	Screw – Hex Washer Hd.	2
276	31588	Plate – Lock	1	380	632370A	Carburetor (Incl. Ref.# 184)	1
277	651002	Screw – Flange Hex Hd.	2	390	590672	Starter – Rewind	1
281	33013	Cover – Starter Hole	1	400	36452	Gasket Set (Incl. items marked *)	1
282	650760	Screw – Pan Hd. Taptite	1	421	730226	SAE 5W30 4-Cycle Oil (Qt.)	1
285	35985B	Hub – Starter	1				
286	35446	Screen – Starter	1				
287	29752	Nut & Lockwasher	4				

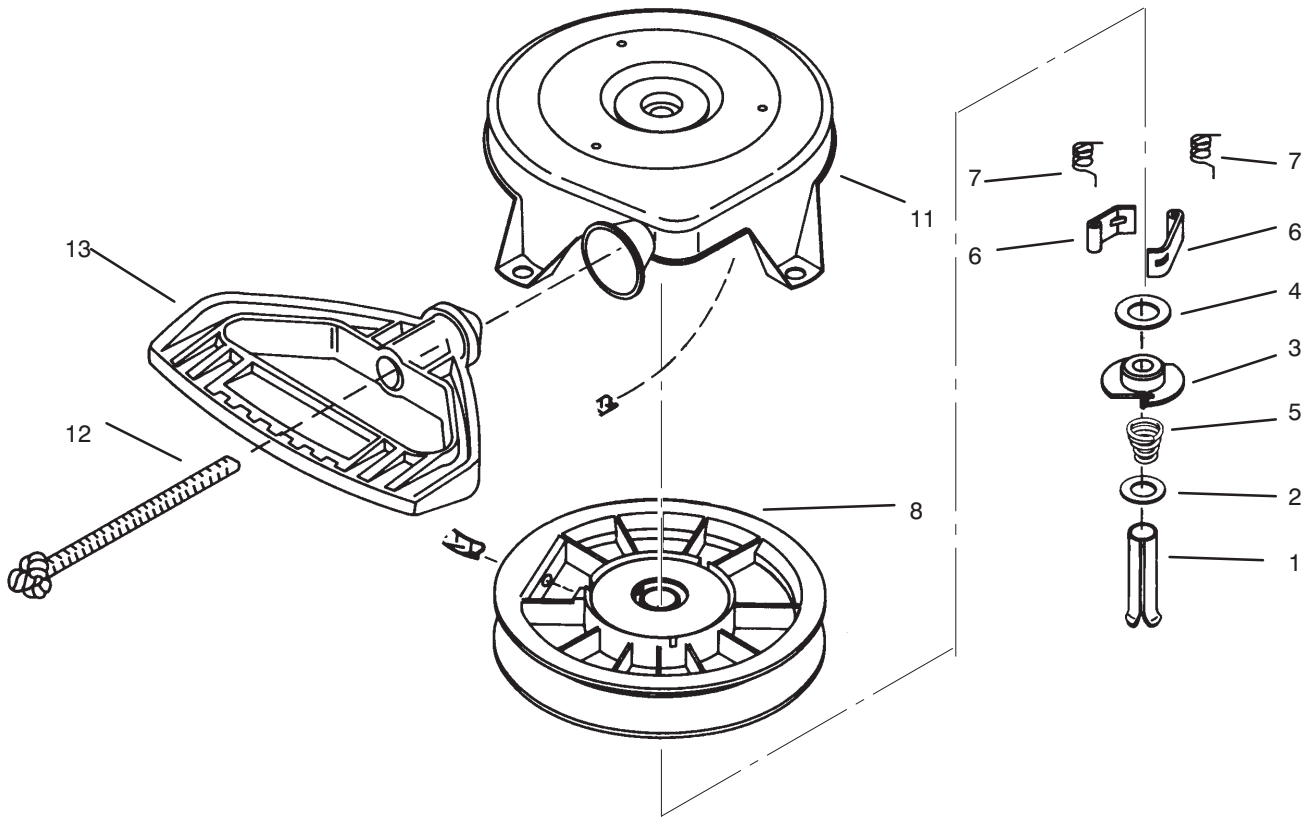

C-1706

REWIND STARTER NO. 590672

Ref. No.	Part No.	Description	No. Used	Ref. No.	Part No.	Description	No. Used
1	590599A	Pin – Spring (Incl. Ref. # 4)	1	8	590682	Pulley & Rewind Spring Assy.	1
2	590600	Washer	1	11	590684	Housing Assy. – Starter	1
3	590679	Retainer	1	12	590456	Rope – Starter (11/64" Dia. & 114" Long)	1
4	590601	Washer	1	13	590574	Handle – Mitten Grip (Not included with Starter)	1
5	590678	Spring – Brake	1				
6	590680	Dog – Starter	2				
7	590412	Spring – Dog	2				

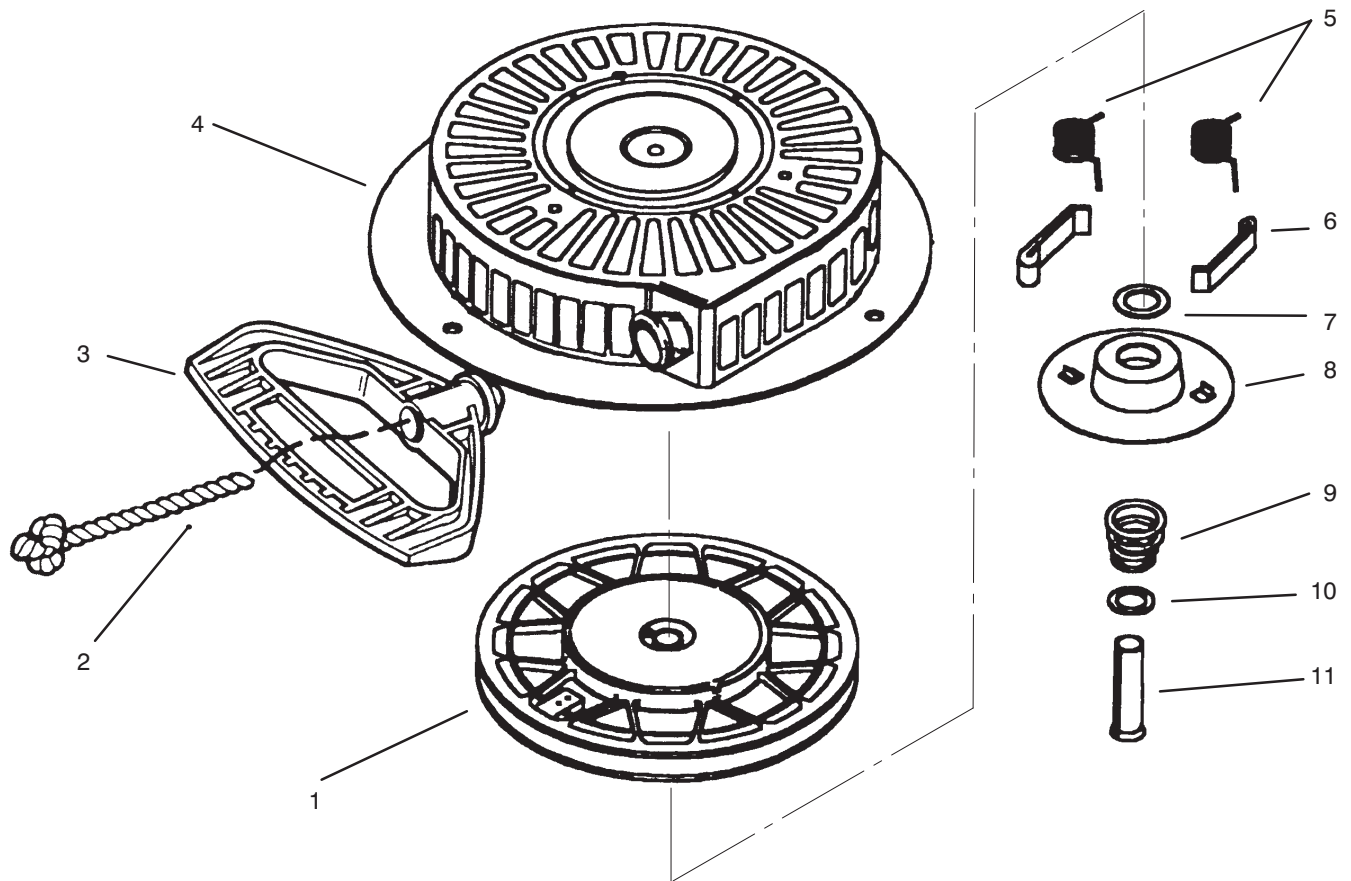

C-

REWIND STARTER TECUMSEH NO. 590733(Optional)

Ref. No.	Part No.	Description	No. Used
1	590709	Pulley & Rewind Spring Assembly	1
2	590535	Rope – Starter	1
‡3	590574	Handle – Mitten Grip	1
4	590534	Starter Housing Asm	1
5	590699	Spring – Dog	2
6	590698	Dog – Starter	2

Ref. No.	Part No.	Description	No. Used
7	590601	Washer	1
8	590676	Retainer	1
9	590697	Spring – Brake	1
10	590600	Washer	1
11	590599A	Pin – Spring (Incl. Ref. #7)	1

‡Not Included in Starter Assembly.

TORO PART NUMBER INDEX

Part No.	Description	Pg. No.	Ref. No.	Qty.	Part No.	Description	Pg. No.	Ref. No.	Qty.
3-0750	Washer - Retaining	1	2	2	62-1100	Lever - Latch	8	7	1
3-4244	Pulley - Idler	7	6	2	62-1110	Lever - Index Wheel	8	3	1
5-2490	Bolt - Shoulder	7	35	2	62-1120	Lever - Reverse	8	22	1
7-0045	Seal - Oil	3	2	2	62-1130	Lever - Reverse	8	20	1
11-0590	Screw - Hex. Hd.	4	23	4	62-1140	Cover - Latch	8	12	1
12-3270	Screw	6	49	3	62-1150	Bushing - Worm	3	16	1
12-8789	Impeller Bearing Assembly	2	*	1	62-1160	Bushing - Intermediate	6	46	4
12-8949	Loose Parts	2	*	1	62-1170	Bushing - Flange	5	38	2
13-3559	Gear - Bevel Reverse 36T	6	59	1	62-1180	Bushing - Output (Flange)	5	1	1
20-0980	Bearing - Auger	2	57	2	62-1190	Bracket - Bellcrank	5	22	1
20-0990	Flange - Bearing (Inner)	2	56	2	62-1230	Washer - Rubber	9	33	1
20-1000	Flange - Bearing (Outer)	2	58	2	62-1290	Knob - Shift	8	1	1
25-5090	Spacer - Auger Hub	2	55	2	62-1300	Pulley - Impeller	1	24	1
29-9570	Bushing - Yoke	6	45	1	62-1310	Pulley - Traction	6	50	1
37-6560	Bushing - Input	3	10	1	62-1320	Knob - Chute Control	9	17	1
38-7820	Bearing - Ball	5	36	2	62-1330	Bolt - Shoulder	7	24	2
40-5940	Switch - On/Off	9	21	1	62-1350	Bushing - Output	5	27	2
52-2861	Washer	2	43	4	62-1381	Handle - R.H.	9	9	1
53-7670	Decal - Danger Auger	1	5	1	62-1430	Retainer - Chute	1	11	3
62-0120	Gear - Helical	3	15	1	62-1440	Cover - Engine Frame	1	32	1
62-0170	Wheel - Index	8	41	1	62-1460	Gear - Universal	9	32	2
62-0180	Tang - Index	8	5	1	62-1470	Base - Lockout	8	42	1
62-0200	Gear - 27T	5	31	1	62-1490	Plate - Guide	9	15	1
62-0210	Gear - 33T	5	43	1	62-1520	Cover - Knob	9	19	1
62-0220	Gear - 34T	5	30	1	62-1531	Shaft - Auger (28")	3	1	1
62-0240	Gear - 45T	5	29	1	62-1640	Lever - Trip	9	12	1
62-0250	Gear - 29T	5	32	1	62-1650	Spring - Torsion	8	6	1
62-0260	Gear - 51T	5	42	1	62-1690	Cover - Detent	5	11	1
62-0280	Latch - Lock	9	6	1	62-1700	Lever - Lockout	8	19	1
62-0290	Cam - Release	9	4	1	62-1710	Spring - Flat	8	16	1
62-0300	Tang - Locking	9	3	1	62-1720	Rod - Chute Gear	1	23	1
62-0310	Key - Shift	6	56	2	62-1740	Bracket - Cable	5	7	1
62-0320	Sleeve	5	28	1	62-5760	Decal - Primer	4	10	1
62-0330	Shaft - Intermediate	5	40	1	63-2030	Rod - Cross	9	27	1
62-0340	Sleeve - Gear 19T	5	34	1	63-2080	Cover - Belt (Upper)	1	28	1
62-0350	Pinion - Bevel 19T	6	53	1	63-2112	Axle Assembly	7	29	1
62-0360	Gear - Compound 19T/41T	5	41	1	63-2150	Frame - Control	8	23	1
62-0370	Gear - 41T	5	35	1	63-2160	Rod - Chute Crank	9	16	1
62-0380	Hub - Pulley	6	52	1	63-2170	Cover - Lever Lock	9	1	1
62-0430	Collar - Shift (Speed)	5	3	1	63-2180	Bracket - Gear	1	7	1
62-0470	Latch - Arm	7	17	1	63-2190	Pin - Gearshift Link	5	15	1
62-0480	Gear Case - Lower	5	44	1	63-2200	Cable - Latch	8	39	1
62-0490	Gear Case - Upper	5	24	1	63-2210	Cable - Gearbox	8	38	1
62-0500	Gear - 15T	6	48	1	63-2220	Spring - Extension	8	8	1
62-0721	Housing - 28"	1	6	1	63-2230	Spring - Extension	8	21	1
3234-5	Screw - Hex. Washer Hd.	2	33	4	63-2240	Spring - Extension	8	17	1
62-0820	Gear - Worm	1	22	1	63-2250	Bushing - Axle	7	26	2
62-0840	Chute Assembly	1	19	1	63-2270	Spring - Torsion	8	40	1
62-0860	Link - Gearshift	5	18	1	63-2280	Washer - Thrust	5	33	1
62-0870	Lever - Gear Shift	5	16	1	63-2300	Retainer - Cable	1	26	1
62-0880	Lever - Direction Shift	5	5	1	63-2400	Decal - Choke	4	12	1
62-0920	Sheave Half - Traction	4	7	1	63-2480	Decal - #2	8	10	1
62-0930	Hub - Sheave	4	5	1	63-2600	Bellcrank	5	20	1
62-0940	Sheave Half - Impeller	4	3	1	63-2610	Pin - Tang	8	9	1
62-0970	Pin - Idler	7	9	1	63-2630	Bracket - Shift	8	33	1
62-1000	Guard - Chain R.H.	7	30	1	63-2640	Joint - Ball	8	36	1
62-1010	Guard - Chain L.H.	7	28	1	63-2640	Joint - Ball	4	17	1
62-1020	Button - Detent	5	10	1	63-2650	Screw - Shoulder	8	18	2
62-1040	Yoke - Shift	5	26	2	63-2670	Plate - Chute Retainer	1	10	3
62-1050	Lever - Impeller	9	8	1	63-2700	Cable - Impeller	9	41	1
62-1060	Lever - Traction	9	24	1	63-2710	Cable - Traction	9	40	1
62-1070	Bushing - Lever	9	11	2	63-2740	Spring - Torsion	7	36	1
62-1080	Shaft - Output	5	37	1	63-2820	Arm - Brake	7	2	1

*Not Illustrated

TORO PART NUMBER INDEX (Cont.)

Part No.	Description	Pg. No.	Ref. No.	Qty.	Part No.	Description	Pg. No.	Ref. No.	Qty.
63-2830	Rod - Shift (Lower)	8	34	1	2210-250	Screw	9	2	3
63-2850	Bracket - Idler Arm	7	3	1	231-123	Tire	7	34	2
63-2870	Spring - Extension	7	14	2	232-48	Tube - Inner	7	33	2
63-2881	Spring - Torsion	7	13	1	241-127	Rim - Wheel	7	32	2
63-2890	Spring - Compression	5	9	1	252-59	Washer - Thrust	5	2	3
63-2900	Washer - Plastic	1	17	2	252-71	Bearing - Thrust	3	5	2
63-2910	Spring - Torsion	9	7	1	252-76	Bearing - Thrust	3	9	1
63-2920	Spring - Extension	5	4	1	252-78	Washer - Thrust	3	8	2
63-2930	Chain - Drive	4	19	1	252-80	Washer - Thrust	7	27	4
63-2951	Belt - Traction	4	6	1	252-80	Washer - Thrust	2	36	1
63-2962	Belt - Impeller	4	4	1	253-149	Seal - Input	3	11	1
63-2990	Frame - Transmission	4	21	1	256-237	Bushing - Sleeve	3	3	2
63-3020	Guard - Chute	1	14	1	256-296	Bushing - Nyliner	8	31	2
63-3050	Decal - Lever	9	25	1	257-9	Washer - Thrust	8	14	1
63-3130	Clip - Chute Guard	1	12	1	257-10	Washer - Thrust	5	39	4
63-3190	Decal - Throttle	4	11	1	281-1	Plug - Pipe Sq. Hd.	3	14	1
63-3290	Cover - Cable	1	29	1	283-3	Pin - Clevis	5	19	1
63-3340	Washer	7	22	4	321-3	Screw - Hex. Hd.	2	60	8
63-3380	Spacer - Traction Lever	9	22	1	321-9	Screw - Hex. Hd.	8	29	1
63-3410	Bolt - Shoulder	5	13	1	321-15	Screw - Hex. Hd.	6	54	1
63-3420	Harness - Wire	9	*	1	321-44	Screw - Hex. Hd.	2	52	2
63-3450	Bearing - Impeller	2	39	1	322-12	Bolt - Auger	2	59	2
63-3740	Decal - Danger Chute	1	20	1	323-6	Screw - Hex. Hd.	1	1	2
63-8360	Key - Switch	9	20	1	323-7	Screw - Hex. Hd.	7	8	2
66-6850	Decal - Panel Top	9	14	1	3210-1	Screw - Hex. Hd.	4	25	2
66-6860	Decal - Warning	9	38	1	3212-8	Screw - Hex. Hd.	4	1	1
66-6860	Decal - Warning	7	40	1	3220-3	Nut - Jam	4	26	1
66-6980	Frame - Engine	1	31	1	3220-3	Nut - Jam	8	35	1
66-7720	Rod - Latch	7	18	1	3230-2	Bolt - Carriage	1	8	1
66-7730	Clevis	8	30	1	3230-23	Screw - Carriage	2	48	10
66-7740	Pivot Arm Assembly	7	23	2	3234-4	Screw - Hex. Washer Hd.	2	61	6
66-7761	Blade - Scraper	2	45	1	3234-5	Screw - Hex. Washer Hd.	2	33	4
66-7811	Shaft - Impeller	3	6	1	3234-7	Screw - Hex. Flange Hd.	4	16	4
66-7821	Plate - Side R.H.	1	3	1	3234-7	Screw - Hex. Flange Hd.	9	26	6
66-7831	Plate - Side L.H.	2	46	1	3234-7	Screw - Hex. Flange Hd.	7	41	2
66-7850	Handgrip	9	10	2	3234-13	Screw - Hex. Hd.	7	5	1
66-7920	Impeller	2	50	1	3234-28	Screw - Hex. Flange Hd.	1	4	12
66-8010	Spacer	2	51	2	3242-4	Screw - Set Sq. Hd.	1	25	2
66-8030	Transmission Assembly	4	20	1	3253-4	Washer - Lock	4	24	2
66-8060	Pad - Brake	7	42	1	3253-6	Washer - Lock	4	2	1
66-8091	Handle - L.H.	9	29	1	3256-1	Washer - Flat	7	21	2
66-8100	Panel - Control	9	13	1	3256-1	Washer - Flat	8	27	2
67-5870	Gear - Bevel 36T	6	57	1	3256-14	Washer - Flat	1	16	3
67-5880	Collar - Shift	6	58	1	3256-14	Washer - Flat	9	43	2
67-9240	Rod - Shift (Upper)	8	2	1	3256-23	Washer - Flat	8	24	3
67-9250	Retainer - Shift Rod	8	28	1	3256-23	Washer - Flat	2	42	1
68-4100	Plate - Engine Stud R.H.	2	*	1	3256-38	Bushing - Idler	7	12	1
68-4110	Plate - Engine Stud L.H.	2	34	1	3256-61	Washer - Flat	1	21	1
68-4310	Gear - 26T	6	47	1	3257-10	Key - Woodruff	3	12	1
68-4320	Sleeve - Shift	6	55	1	3257-23	Key - Woodruff	2	35	1
68-7451	Auger - R.H.	2	54	1	3269-23	Rivet	1	30	4
68-7461	Auger - L.H.	2	*	1	3272-1	Pin - Cotter	5	17	1
68-7510	Guide - Belt	4	8	1	3274-13	Screw - Machine	1	13	3
68-8410	Cover - Belt (Lower)	2	41	1	3290-243	Pin - Klik	7	38	2
74-1440	Skid Assembly	2	44	2	3290-320	Nut - Push	8	15	1
74-1561	Auger Gearbox Assembly	2	53	1	3290-320	Nut - Push	9	18	2
74-1570	Gearcase Assembly - L.H.	3	13	1	3290-326	Nut - Push	1	15	2
74-1580	Gearcase Assembly - R.H.	3	4	1	3290-359	Screw	9	28	1
88-0590	Decal - Panel Front	9	36	1	3290-378	Tie - Cable	9	30	4
88-0810	Spring - Extension	9	39	1	3290-422	Nut - Push	8	4	1
93-8045	Arm - Traction Idler	7	10	1	3290-456	Washer - Belleville	8	37	1
93-8046	Arm - Impeller Idler	7	11	1	3290-461	Washer - Belleville	7	16	2
94-2560	Decal - Hot Surface	4	14	1	3290-461	Washer - Belleville	4	22	4

*Not Illustrated

TORO PART NUMBER INDEX (Cont.)

3317-687

Part No.	Description	Pg. No.	Ref. No.	Qty.	Part No.	Description	Pg. No.	Ref. No.	Qty.
3290-476	Fastener - Panel	7	37	1	32104-118	Screw - Pan Hd.	8	11	2
3290-477	Washer - Curved	5	14	1	32104-118	Screw - Pan Hd.	9	35	2
3296-2	Nut - Lock	1	9	4	32104-121	Screw - Hex. Flange Hd.	7	31	3
3296-2	Nut - Lock	9	23	1	32120-46	Ring - Retaining	7	1	2
3296-23	Nut - Lock	7	25	2	32120-46	Ring - Retaining	8	13	1
3296-29	Nut - Lock	8	25	7	32121-9	Pin - Roll	7	19	2
3296-29	Nut - Lock	2	37	12	32121-50	Pin - Roll	9	31	2
3296-39	Nut - Lock	7	15	2	32121-106	Pin - Coil	5	6	3
3296-39	Nut - Lock	4	18	1	32122-32	Screw	1	18	1
3296-39	Nut - Lock	8	32	1	32128-20	Nut - Lock	4	15	4
3296-42	Nut - Lock	9	42	4	32128-32	Nut - Flange Lock	6	51	1
3296-42	Nut - Lock	7	4	1	32144-4	Screw	4	13	1
3296-42	Nut - Lock	5	23	1	32144-4	Screw - Hex. Flange Hd.	1	27	6
3296-42	Nut - Lock	8	26	1	32144-4	Screw - Hex. Flange Hd.	7	20	2
3296-42	Nut - Lock	2	49	10	32144-4	Screw - Self Tapping	5	8	2
3296-47	Nut - Lock	9	37	4	32144-86	Screw - Hex Washer Hd.	5	25	6
3296-47	Nut - Lock	7	39	2	32144-110	Screw - Hex. Washer Hd.	3	17	9
3296-47	Nut - Lock	2	47	12	32151-33	Ring - Snap	3	7	1
3296-59	Nut - Lock	7	7	2	32151-66	Ring - Retaining	9	5	1
32104-71	Screw - Pan Hd.	5	12	1	505-101	Grease - 14.5 oz.	6	*	1
32104-76	Screw - Self Tapping	9	34	2	505-129	Sealant - 100g Tube	3	*	1
32104-95	Screw - Hex. Washer Hd.	5	21	2					

Accessories

Description	Model / Parts No.	Description	Model / Parts No.
Tire Chains Kit	63-3040	Snow Cab	68-9500
Weight Kit	74-1190	Differential Kit	38038
Drift Breaker	66-7970	110V Starter Kit	37-4810

*Not Illustrated

