

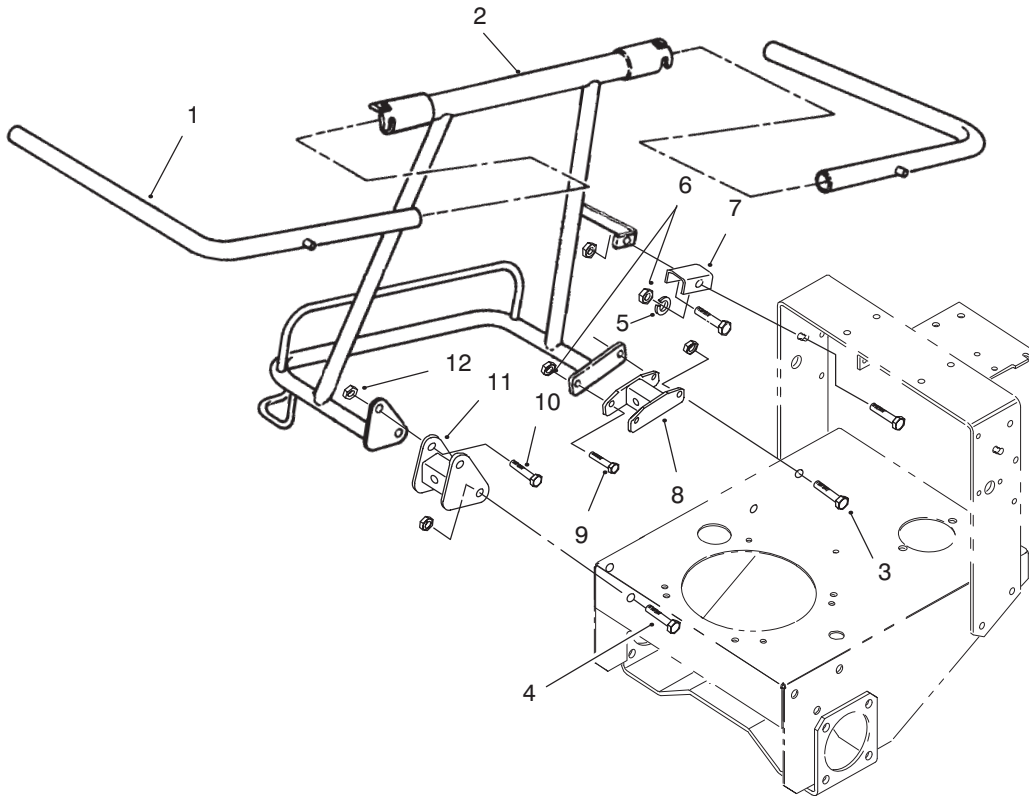

MODEL NO. 30124-690001 & UP

**PARTS  
CATALOG**

**32" BAGGING KIT  
PROLINE MID-SIZE TRACTION UNIT**



T-0003

**FRAME ASSEMBLY**

Ref. No.	Part No.	Description	No. Used
1	67-6640	Frame - Bagger	2
2	74-1040	Support - Bagger	1
3	323-7	Screw - Hex Hd. Cap	2
4	3234-32	Screw - Hex Hd. Flange	2
5	3256-24	Washer - Flat	1
6	3296-39	Nut - Lock	2
7	93-4371	Bracket	1
8	93-4369	Adapter	1

Ref. No.	Part No.	Description	No. Used
9	323-4	Screw	2
10	325-5	Screw	2
11	93-4370	Adapter	1
12	3296-23	Nut - Lock	2
*13	68-3560	Elbow - Exhaust	1
*14	2412-111	Clamp	1
	93-4372	Kit - Adapter, 32" Bagger (Incl. Ref. 6-14)	

\* Not Illustrated

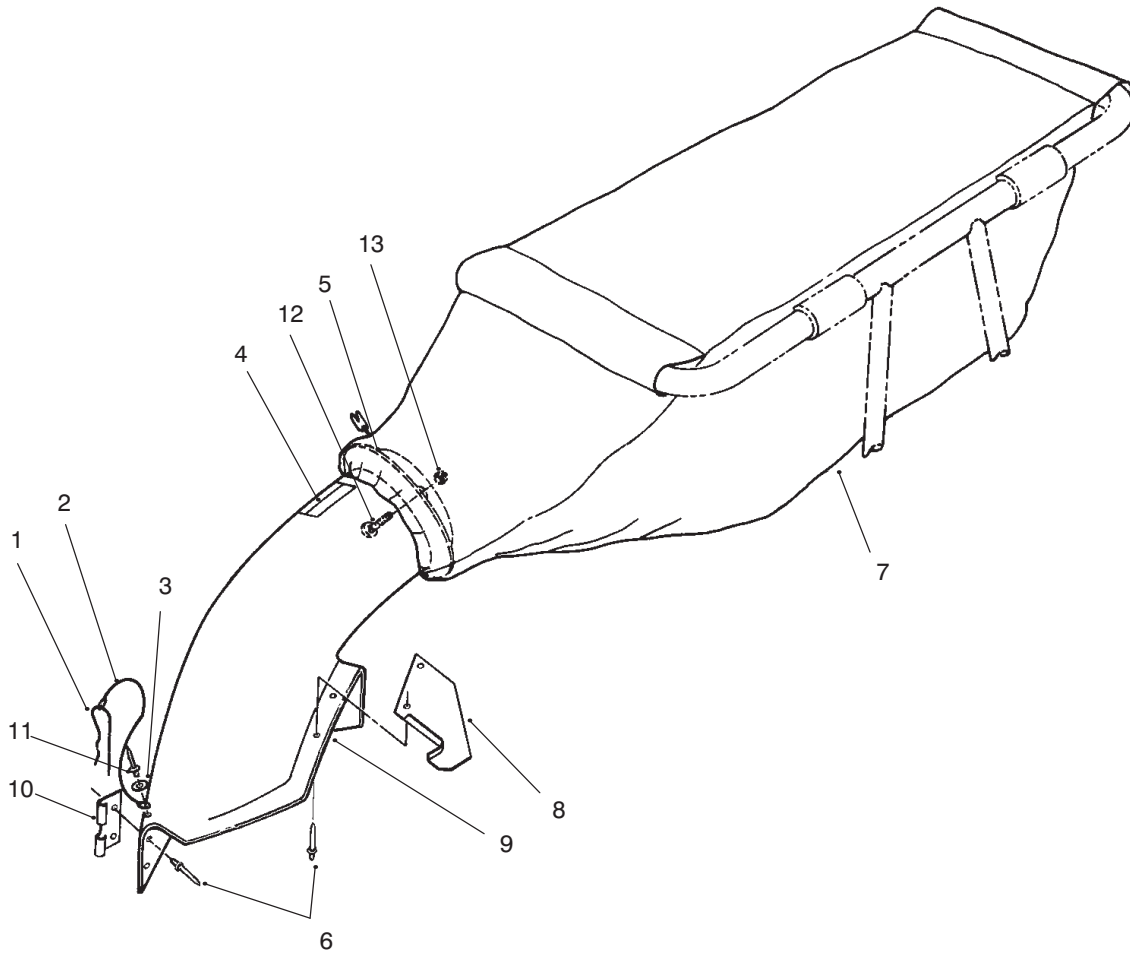

T-0004

## CHUTE & BAG ASSEMBLY

Ref. No.	Part No.	Description	No. Used
1	28-8130	Pin - Chute Locking	1
2	28-8070	Lanyard	1
3	3256-49	Washer - Flat	1
4	93-1122	Decal - Danger	1
5	67-6690	Ring - Bagger	1
6	3290-412	Rivet - Pop	4
7	67-6580	Bag Assembly	1
8	33-2090	Bracket - Chute Support	1

Ref. No.	Part No.	Description	No. Used
9	67-6800	Chute Assembly (Incl. Ref. #1-6, & 8, 10-13)	1
10	28-8050	Bracket - Chute Mount	1
11	3290-282	Rivet - Pop	1
12	3229-11	Screw - Hex Hd. Cap	4
13	3296-42	Nut - Lock	4

\*Not Illustrated