



Count on it.

Parts Catalog

Workman® MDX Utility Vehicle

Model No. 07273TC—Serial No. 31000001 and Up

Ordering Replacement Parts

To order replacement parts, please supply the part number, the quantity, and the description of each part desired.

Understanding Reference Numbers

Each identified part in an illustration has a reference number. The reference number for a part also appears in the parts list, along with other information about the part.

This catalog uses two special reference number formats, one to indicate parts in a service assembly and another to indicate the quantity of a given part in an illustration.

Service Assembly Reference Numbers

Parts in service assemblies have reference numbers in the form a:b. The a represents the reference number of the entire service assembly and the b represents a sequential number unique to each part within the service assembly.

For example, a wheel assembly might be identified by reference number 6, the tire by 6:1, the valve by 6:2, and the wheel by 6:3. When you order the assembly identified by reference number 6, you receive all parts identified by reference numbers 6:1, 6:2, and 6:3. However, you may also order any part individually. Reference numbers of this type appear in illustration and in parts lists.

Reference Numbers Indicating Quantity

In an illustration, if a reference number indicates more than one part, the reference number has the form nX y. The n represents the quantity of the part, the X is the multiplication symbol, and the y represents the reference number.

For example, in an illustration, the reference number 2X 37 means that two of the parts identified by reference number 37 are indicated.

List of Abbreviations

AR: as required

ASM: assembly

BBC: blade brake clutch

CARR: carriage

CCW: counter clock wise

CW: clockwise

DEG: degrees

ECM: electronic control module

EXT: external

FH: flat head

GA: gauge

HD: heavy-duty

HF: hex flange

HH: hex head

HHF: hex head flange

HHFTF: hex head flange thread forming

HJ: hex jam

HLH: hex lag head

HOC: height-of-cut

HSBH: hex socket button head

HSFH: hex socket flat head

HSH: hex socket head

HWH: hex washer head

HWHTF: hex washer head thread forming

HYD: hydraulic

LH: left hand

NI: nylon insert

NPTF: national pipe thread fine

PFH: phillips flat head

PPH: phillips pan head

PPHTF: phillips pan head thread forming

PRH: phillips round head

PTH: phillips truss head

PTO: power-take-off

RH: right hand

ROPS: roll-over protection system

RRB: rear roller brush

SFH: slotted fillister head

SHH: slotted hex head

SHWH: slotted hex washer head

SPH: slotted pan head

SQH: square head

SRH: slotted round head

STD: standard

TAP: self tapping

TTH: torx truss head

Contents

Dash Assembly	4
Pedal Box Assembly	6
Shifter Assembly	7
Front Frame Assembly	8
Seat Base Assembly	9
Front Tire, Spindle and Tie Rod Assembly	10
Engine and Clutch Assembly	11
Primary Clutch Assembly No. 119-0800	13
Starter Generator Assembly No. 99-7108	14
Rear Tire and Transaxle Assembly	15
Transaxle Assembly No. 119-0760	16
LH Rear Brake Assembly No. 114-8332	18
RH Rear Brake Assembly No. 114-8331	19
Secondary Clutch Assembly No. 119-0803	20
Oil Filter and Air Cleaner Assembly	21
Air Cleaner Assembly No. 99-7120	22
Upper Steering Assembly	23
Steering Box Assembly No. 112-3130	24
Box and Tailgate Installation Assembly	25
Box and Tailgate Assembly	26
Hood and Fender Assembly	27
Frame Assembly	28
Master Cylinder and Brake Line Assembly	29
Master Cylinder Assembly No. 104-6782	30
Attachments and Accessories	31

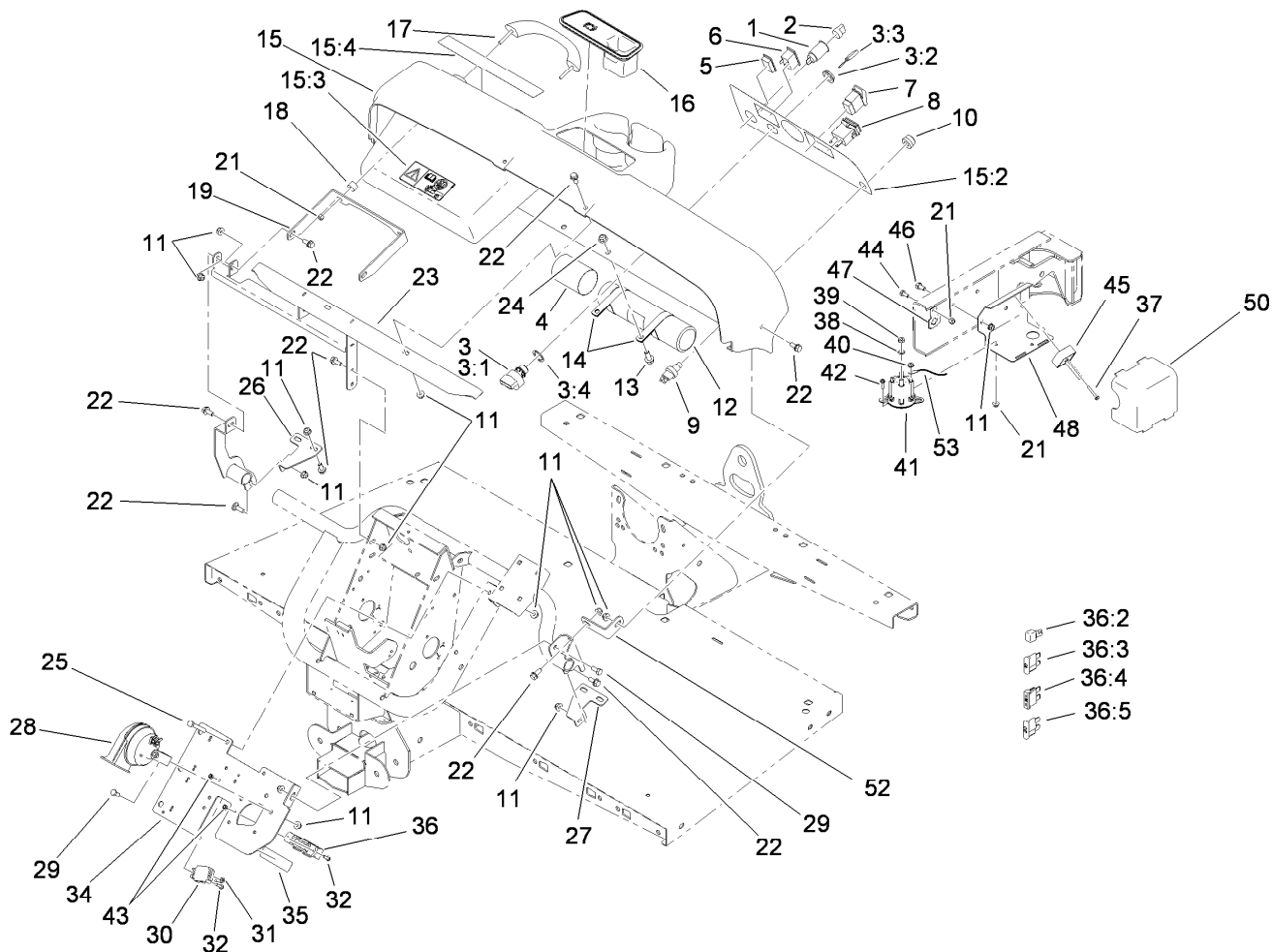

Dash Assembly

Ref.	Part Number	Qty.	Description	Ref.	Part Number	Qty.	Description
1	99-7411	1	Point-Power	19	112-3391-03	1	Bracket-Grip, Handle
2	99-7416	1	Cap	21	104-7201	5	Nut-HF
3	112-3323	1	Ignition Switch ASM	22	110-5053	15	Screw-Flange
3:1		1	Switch-Ignition ●	23	115-7651-03	1	Dash Support ASM
3:2	108-8660	1	Nut-Mounting	24	104-8301	2	Nut-Flange, NI
3:3	99-7418	1	Key-Ignition	25	322-11	2	Screw-HH
3:4	108-8659	1	Washer-Backup	26	114-8304	1	Bracket-Dash Mount, RH
4	104-7048	1	Cap-Housing	27	114-8312	1	Bracket-Dash Mount, LH
5	99-7420	1	Plug-Hole	28	110-2594	1	Horn ASM
6	99-7410	1	Indicator-Light, Low-Oil Pressure	29	322-3	2	Screw-HH
7	95-8999	1	Switch	30	42862	1	Block-Terminal, Ground
8	94-4208	1	Hourmeter	31	42863	1	Strip-Jumper
9	112-3324	1	Switch-Horn	32	32105-13	4	Screw-HWH
10	112-3313	1	Cap And Nut ASM	34	112-3376-03	1	Plate-Mount, Electrical
11	104-8300	21	Nut-Flange, NI	35	112-3325	1	Decal-Block, Fuse
12	104-7050	1	Tube-Manual	36	115-8137	1	Harness-Wire, Main
13	3234-11	2	Screw-HHF	36:2	100-4918	1	Diode
14	2412-133	2	R-Clamp	36:3	218-578	1	Fuse-10 Amp
15	114-8310	1	Dash ASM	36:4	109355	1	Fuse-15 Amp
15:2	117-5001	1	Decal-Control Panel	36:5	109101	1	Fuse-20 Amp
15:3	104-6581	1	Decal-Danger	37	100-4352	1	Screw-HWH
15:4	115-2412	1	Decal-No Storage	38	3255-8	2	Washer-Lock
16	104-6930	1	Plug-Rubber	39	3220-2	2	Nut-Jam
17	112-3320	1	Handle-Grip	40	32149-8	2	Nut-Keps
18	114-8301	2	Spacer	41	114-3315	1	Solenoid-12 Vdc
				42	3234-33	2	Screw-HHF

● Not serviced separately

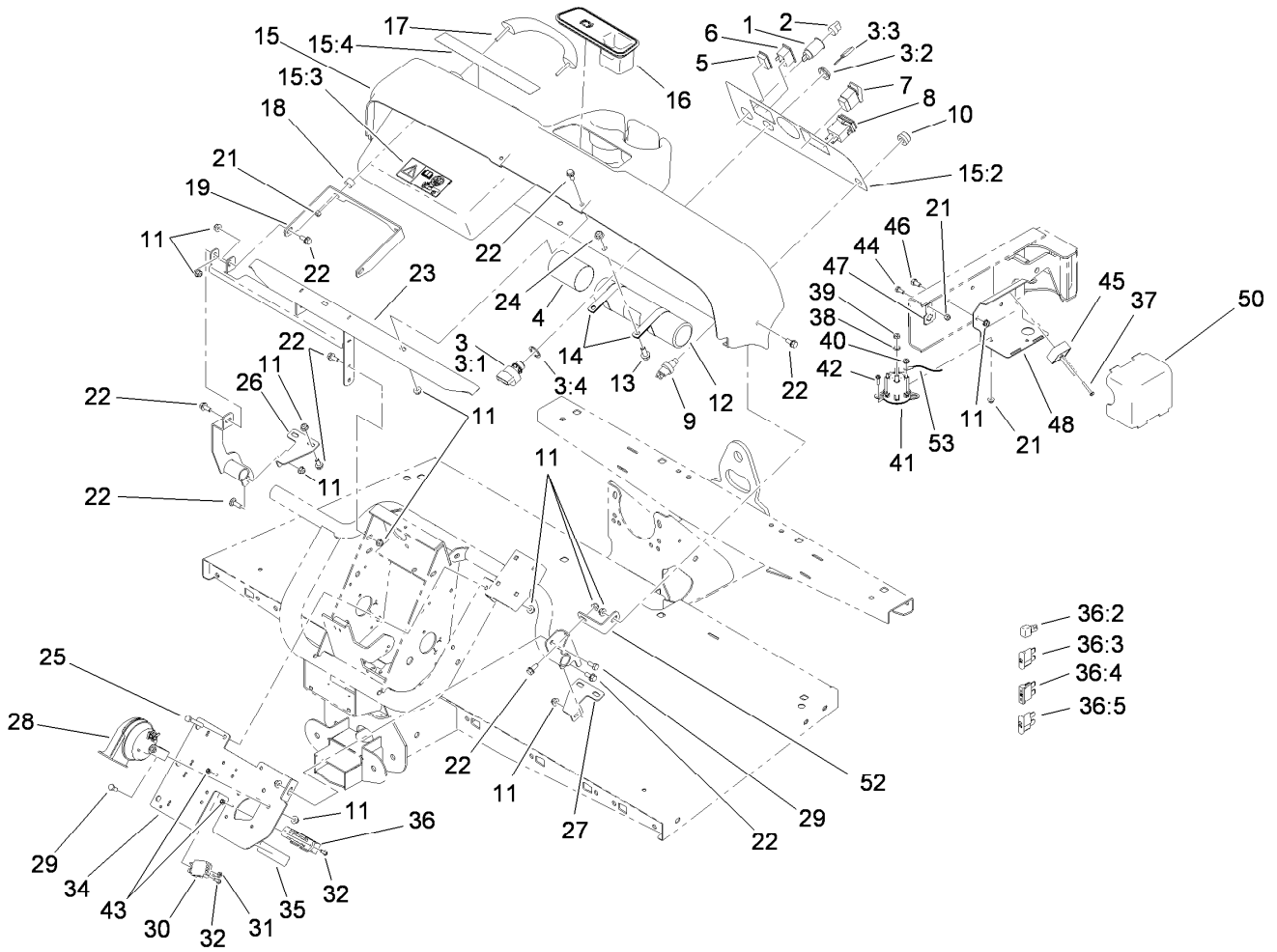

Dash Assembly (continued)

<i>Ref.</i>	<i>Part Number</i>	<i>Qty.</i>	<i>Description</i>	<i>Ref.</i>	<i>Part Number</i>	<i>Qty.</i>	<i>Description</i>
43	3296-2	4	Nut-Lock, NI	48	119-0752-03	1	Mount-Component
44	321-3	1	Screw-HH	50	112-3027	1	Cover-Controller
45	104-6927	1	Regulator	52	114-8305	1	Angle-Mount, Dash (LH)
46	322-2	2	Screw-HH	53	112-3537	1	Cable-Battery, Positive
47	114-5502	1	Clip-Fuse				

● Not serviced separately

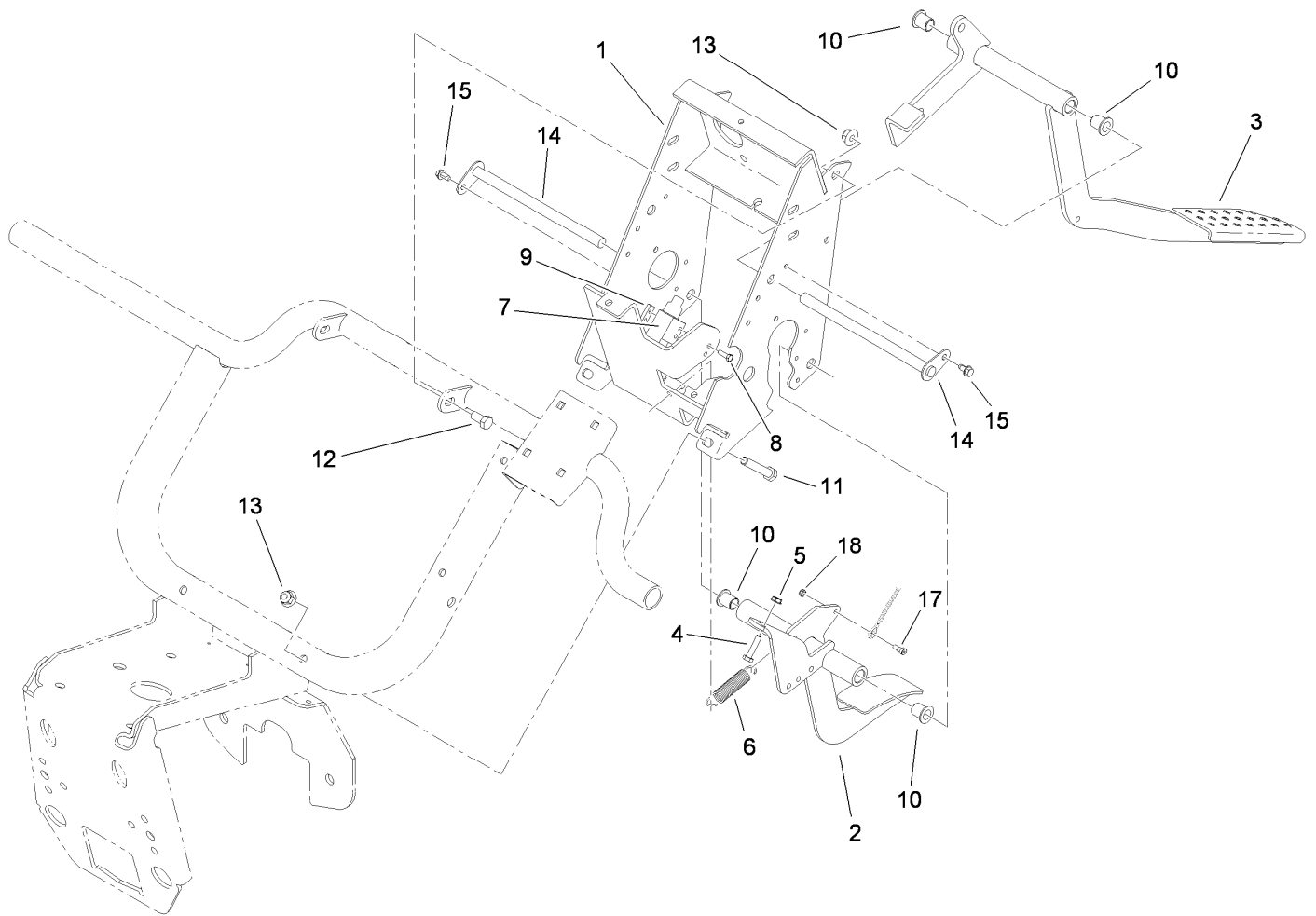

Pedal Box Assembly

<i>Ref.</i>	<i>Part Number</i>	<i>Qty.</i>	<i>Description</i>	<i>Ref.</i>	<i>Part Number</i>	<i>Qty.</i>	<i>Description</i>
1	119-0748-03	1	Pedal Support Frame ASM	10	256-155	4	Bushing-Flange
2	115-7630-03	1	Throttle Pedal ASM	11	323-11	2	Screw-HH
3	112-3314-03	1	Brake Pedal ASM	12	323-4	2	Screw-HH
4	321-7	2	Screw-HH	13	104-8301	4	Nut-Flange, NI
5	32149-2	2	Nut-Keps	14	104-7164	2	Pivot-Pedal
6	104-6415	1	Spring-Return, Pedal	15	12-3270	2	Screw
7	99-7407	1	Switch	17	115-7632	1	Bolt-Shoulder
8	3290-134	2	Screw	18	3296-47	1	Nut-Lock, NI
9	1-633181	1	Plate-Tapped				

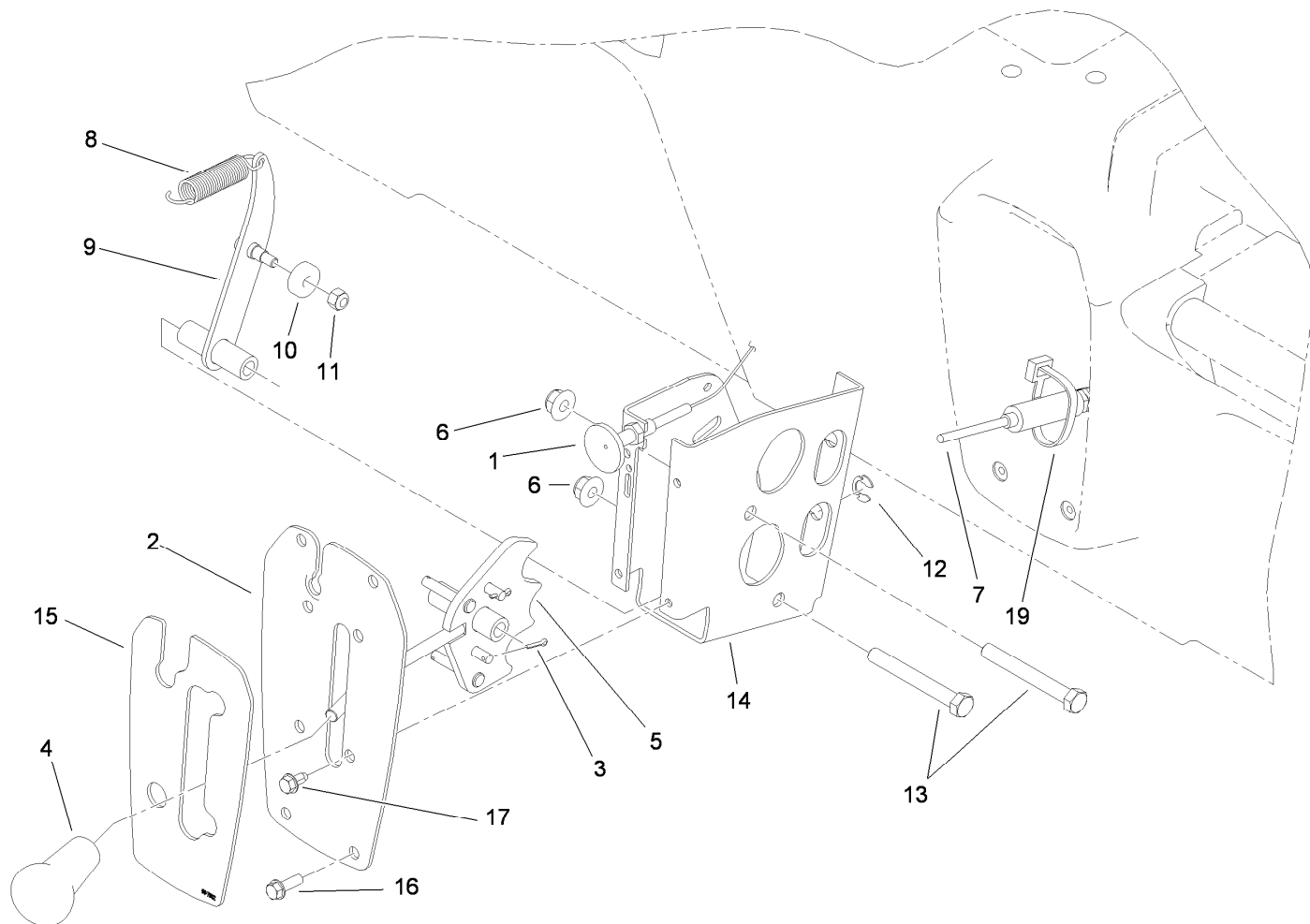

Shifter Assembly

<i>Ref.</i>	<i>Part Number</i>	<i>Qty.</i>	<i>Description</i>	<i>Ref.</i>	<i>Part Number</i>	<i>Qty.</i>	<i>Description</i>
1	99-7111	1	Cable-Choke	10	251-307	1	Bearing-Ball
2	99-7887-03	1	Plate-Shifter	11	3296-42	1	Nut-Lock, NI
3	3272-5	2	Pin-Cotter	12	32151-101	2	E-Ring
4	99-7981	1	Knob-Grip, Soft	13	323-14	2	Screw-HH
5	114-2719	1	Plate-Detent	14	108-3141-03	1	Bracket-Shift
6	104-8301	2	Nut-Flange, NI	15	99-7952	1	Decal-Shifter
7	115-7679	2	Tension Cable Control ASM	16	32105-15	4	Screw
8	104-6415	1	Spring-Return, Pedal	17	12-3270	4	Screw
9	108-3138	1	Arm-Detent	19	3290-378	1	Tie-Cable

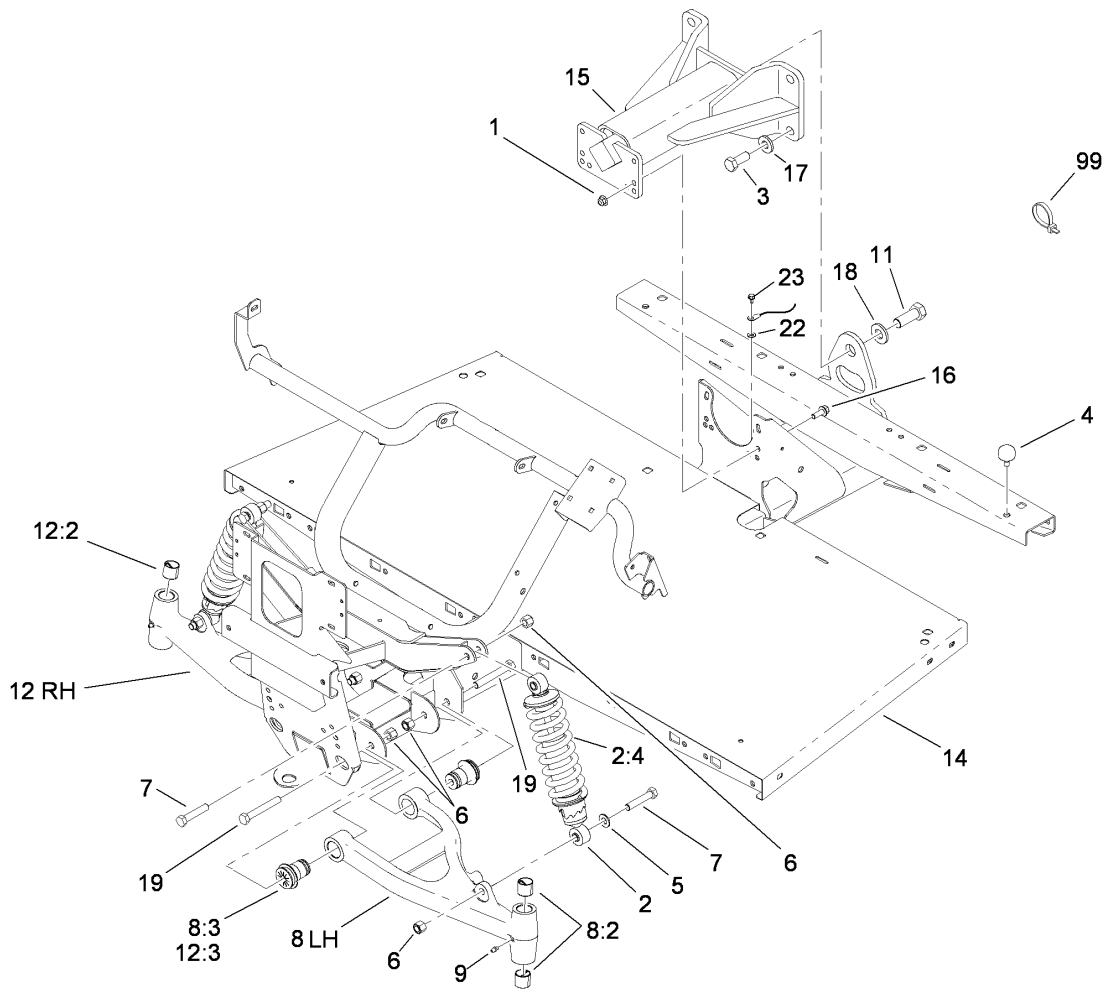

Front Frame Assembly

<i>Ref.</i>	<i>Part Number</i>	<i>Qty.</i>	<i>Description</i>
1	104-8301	4	Nut-Flange, NI
2	112-2975	2	Shock/Spring ASM
2:4	112-3383	1	Spring
3	327-4	4	Screw-HH
4	87-2440	1	Bumper-Rubber
5	51-3500	2	Washer
6	3296-23	8	Nut-Lock, NI
7	325-10	4	Screw-HH
8	114-8313	1	LH A-Arm ASM
8:2	3-0348	2	Bushing
8:3	87-1450	2	Bushing-Flange
9	302-5	2	Fitting-Grease
11	328-24	1	Screw-HH

<i>Ref.</i>	<i>Part Number</i>	<i>Qty.</i>	<i>Description</i>
12	114-8314	1	RH A-Arm ASM
12:2	3-0348	2	Bushing
12:3	87-1450	2	Bushing-Flange
14	112-3340-03	1	Front Frame ASM
15	99-7700	1	Pivot Yoke ASM
16	3234-11	4	Screw-HHF
17	99-7667	4	Washer-Flat
18	87-3060	1	Washer-Hardened
19	325-14	4	Screw-HH
22	3254-16	1	Washer-Lock/Int
23	12-3270	1	Screw
99	3290-379	12	Tie-Cable

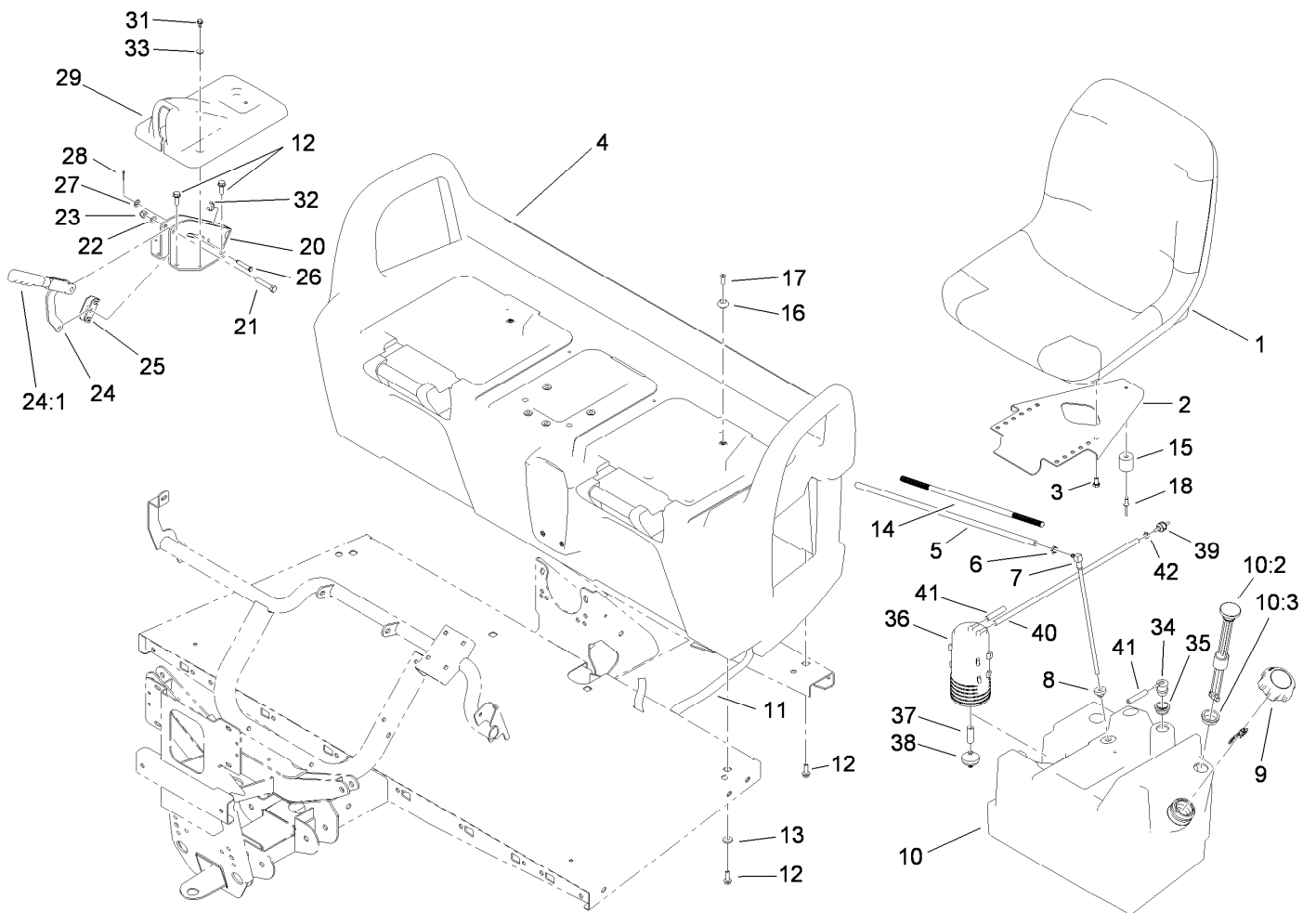

Seat Base Assembly

<i>Ref.</i>	<i>Part Number</i>	<i>Qty.</i>	<i>Description</i>	<i>Ref.</i>	<i>Part Number</i>	<i>Qty.</i>	<i>Description</i>
1	112-2923	2	Seat ASM	22	3290-477	1	Washer-Curved
2	99-7829	2	Bracket-Seat	23	3296-39	1	Nut-Lock, NI
3	33114-016	8	Screw-HH	24	104-6842	1	Lever-Brake, Park
4	104-6847	1	Seat Base ASM	24:1	106-7972	1	Grip-Handle
5	110-4103	1	Hose-Fuel	25	87-3480	1	Bracket-Equalizer, Cable
6	2412-98	1	Clamp	26	94-3829	1	Pin-Clevis
7	99-7264	1	Pipe-Stand	27	3256-23	1	Washer-Flat
8	46-6560	1	Bushing	28	3272-6	1	Pin-Cotter
9	115-7788	1	Cap-Fuel	29	104-7014	1	Cover-Brake, Parking
10	119-0784	1	Fuel Tank ASM	31	12-3270	2	Screw
10:2	99-7262	1	Gauge-Fuel	32	32120-47	1	Ring-Retaining, External
10:3	95-8972	1	Grommet	33	3256-1	2	Washer-Flat
11	3339-175	1	Strapping-Web, 48 Inch	34	114-0285	1	Valve-Rollover
12	3234-17	12	Screw-HHF	35	114-0284	1	Grommet-Valve, Rollover
13	88-7200	8	Washer-Flat	36	117-1221	1	Canister-Carbon, 800Cc
14	112-3337	1	Conduit-Line, Fuel	37	106-5317	1	Hose-Fuel
15	99-7830	2	Rubber Receptical ASM	38	115-7854	1	Filter-Fuel, Inline
16	99-7833	2	Post-Holding	39	115-7868	1	Valve-Check, Vacuum
17	32108-5	2	Screw-FH	40	110-8751	1	Hose-Fuel
18	3290-412	2	Rivet	41	110-8751	1	Hose-Fuel
20	104-6844-03	1	Support-Brake, Park	42	2412-136	1	Clamp-Hose
21	323-10	1	Screw-HH				

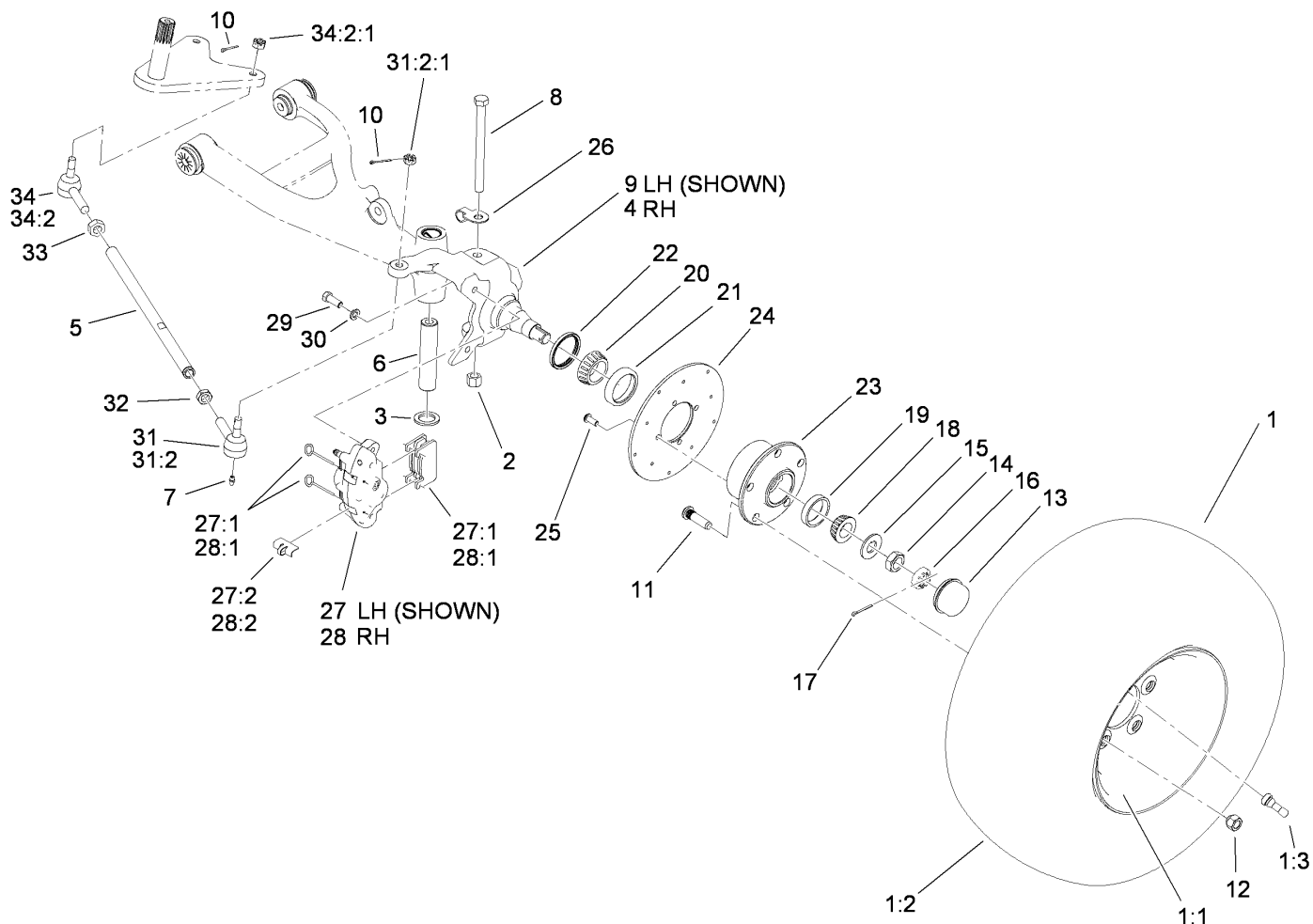

Front Tire, Spindle and Tie Rod Assembly

Ref.	Part Number	Qty.	Description	Ref.	Part Number	Qty.	Description
1	104-7290	2	Tire And Wheel ASM	21	254-107	2	Cup-Bearing, Tapered
1:1	104-7288	1	Wheel	22	108-7019	2	Seal-Shaft
1:2	104-7289	1	Tire	23	104-6809	2	Hub
1:3	232-27	1	Stem-Valve	24	104-6891	2	Rotor
2	3296-23	2	Nut-Lock, NI	25	3274-55	8	Screw-HSBH
3	256-115	2	Washer-Thrust	26	112-3311	2	Clip-Hose
4	112-3167	1	Spindle-RH	27	112-3150	1	Caliper-LH
5	115-7654	2	Tie Rod	27:1	107-0708	1	Friction Pad And Pin Kit
6	99-7499	2	Sleeve-Kingpin	27:2	112-3152	1	Spring-Rattle, Anti
7	302-5	4	Fitting-Grease	28	112-3151	1	Caliper-RH
8	325-20	2	Screw-HH	28:1	107-0708	1	Friction Pad And Pin Kit
9	112-3166	1	Spindle-LH	28:2	112-3152	1	Spring-Rattle, Anti
10	3272-7	4	Pin-Cotter	29	323-6	4	Screw-HH
11	10-6830	10	Stud-Type, Drive	30	3253-21	4	Washer-Lock
12	242-50	10	Nut-Lug	31	112771-03	2	LH Ball Joint ASM
13	241-119	2	Cap-Dust	31:2		1	Joint-Ball, LH ●
14	3220-7	2	Nut-Jam	31:2:1	915031	1	Nut
15	93-0309	2	Washer-Tab	32	3218-21	2	Nut-Jam
16	93-0307	2	Nut-Lock, Retainer	33	3220-11	2	Nut-Jam
17	3272-12	2	Pin-Cotter	34	112772-03	2	RH Ball Joint ASM
18	254-94	2	Bearing-Cone, Tapered	34:2		1	Joint-Ball, RH ●
19	254-72	2	Bearing-Cup, Tapered	34:2:1	915031	1	Nut
20	254-106	2	Cone-Bearing, Tapered				

● Not serviced separately

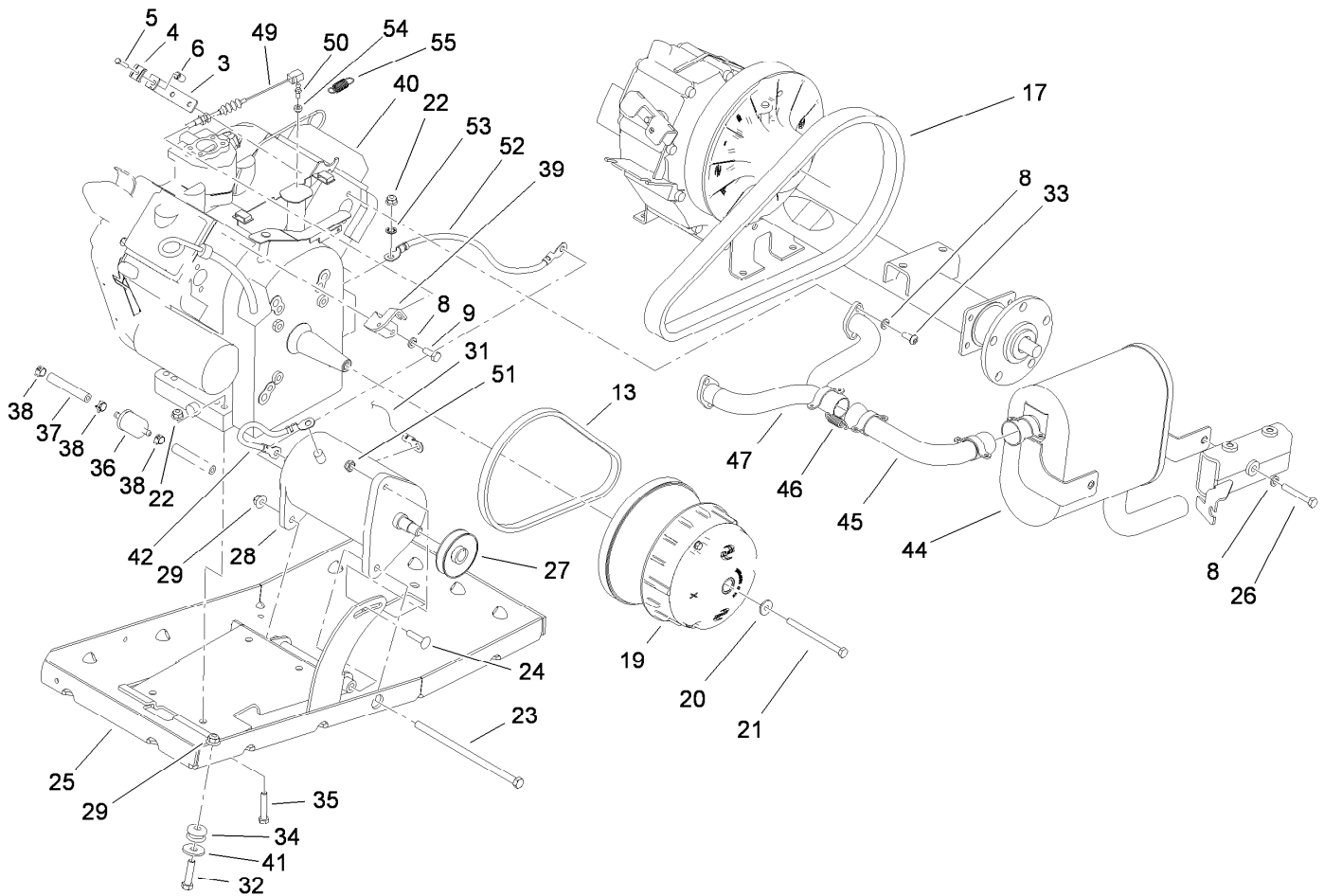

Engine and Clutch Assembly

Ref.	Part Number	Qty.	Description	Ref.	Part Number	Qty.	Description
3	107-0319	1	Bracket-Cable	31	115-8109	1	Harness-Wire, Engine
4	81-1690	1	Clamp-Cable	32	323-8	2	Screw-HH
5	3290-432	1	Screw-HH	33	3274-96	4	Screw-HSBH
6	32148-14	1	Insert-Threaded	34	63-9750	2	Mount
8	3253-4	8	Washer-Lock	35	322-9	4	Screw-HH
9	66-3160	2	Screw-Cap	36	94-2690	1	Filter-Fuel
13	112-2911	1	Belt-Starter	37	114-3765	1	Hose-Fuel
17	119-0711	1	Belt-Variable	38	2412-98	3	Clamp
19	119-0800	1	Clutch-Primary	39	115-2393	1	Bracket-Cable
20	119-0724	1	Washer-Flange	40	117-2714	1	Engine-Briggs & Stratton, 295440-0153-G2 ●
21	119-0722	1	Screw-HH	41	2844	2	Washer
22	104-8300	4	Nut-Flange, NI	42	99-7403	1	Cable-Negative
23	323-30	1	Screw-HH	44	119-0746	1	Muffler
24	112-6950	1	Screw-CARR	45	119-0717	1	Pipe-Exhaust
25	119-0709-03	1	Engine Tray ASM	46	104-6478	4	Spring-Coupler, Exhaust
26	322-11	2	Screw-HH	47	104-6476	1	Manifold-Engine
27	99-7130	1	Pulley-Starter	49	115-7612	1	Cable-Accelerator
28	99-7108	1	Starter Generator ASM	50	99-7847	1	Ball-Stud
29	104-8301	3	Nut-Flange, NI				

● Obtain parts from www.briggsandstratton.com

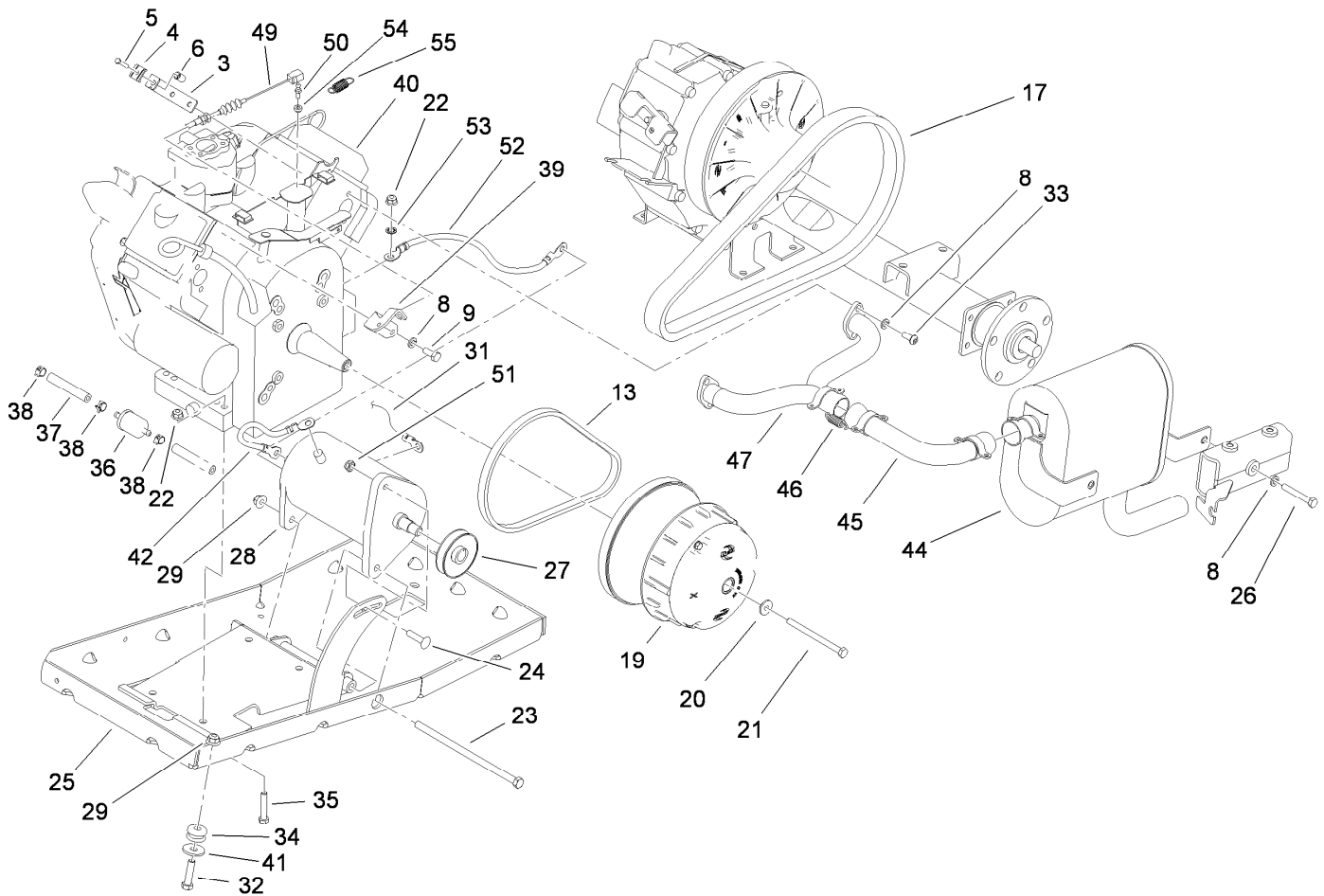

Engine and Clutch Assembly (continued)

<i>Ref.</i>	<i>Part Number</i>	<i>Qty.</i>	<i>Description</i>	<i>Ref.</i>	<i>Part Number</i>	<i>Qty.</i>	<i>Description</i>
51	3296-69	1	Nut-Lock NI	54	110-2619	1	Keeper-Spring
52	94-2777	1	Wire-Ground	55	71-5470	1	Spring-Brake
53	3254-2	1	Washer-Lock, Internal				

● Obtain parts from www.briggsandstratton.com

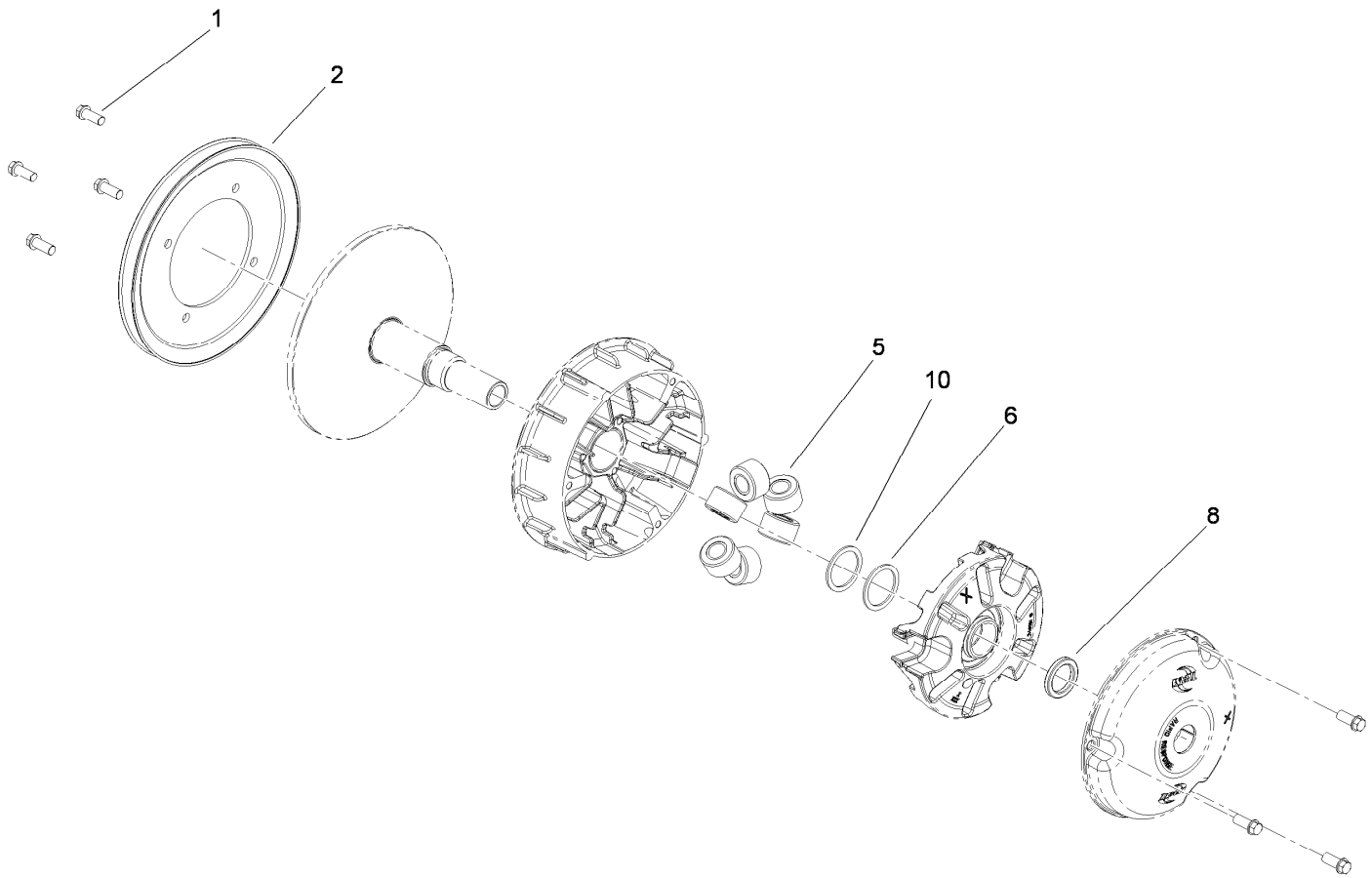

Primary Clutch Assembly No. 119-0800

<i>Ref.</i>	<i>Part Number</i>	<i>Qty.</i>	<i>Description</i>
1	49-2040	7	Screw-HWHTF
2	119-0813	1	Pulley-Primary
5	119-0804	6	Weight-Roller (47Gm)
6	119-0812	1	Shim-Spider
8	119-0806	1	Shim-Limiter (.250)
10	119-0815	1	Shim-Spider

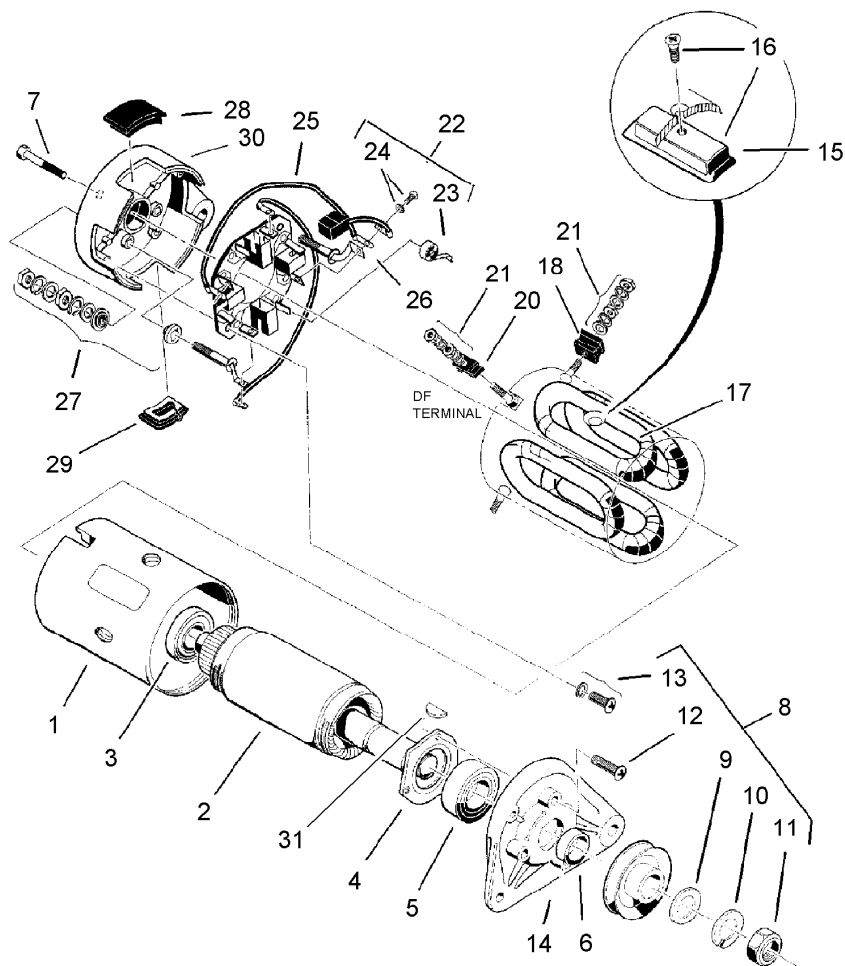

Starter Generator Assembly No. 99-7108

Ref.	Part Number	Qty.	Description	Ref.	Part Number	Qty.	Description
1		1	Yoke ●	16	104-1221	1	Set-Pole And Screw
2	104-1210	1	Armature Kit	17	104-1222	1	Field Stator Coil ASM
3	104-1211	1	Bearing-Ball, Rear	18		2	F Mold ●
4	104-1212	1	Retainer	20		1	Df Mold ●
5	104-1213	1	Bearing-Ball, Front	21	104-1224	1	Nut And Washer Set
6	104-1214	1	Spacer	22	104-1225	1	Brush Holder Kit
7	104-1215	2	Bolt	23	104-1226	4	Spring-Brush
8		1	Nut And Screw Set ●	24	104-1227	1	Brush And Screw Set
9	104-1216	1	Washer-Plain	25		2	Brush Connector ASM ●
10	104-1217	1	Washer-Spring	26		2	A Terminal ASM ●
11	104-1218	1	Nut-Hex	27	104-1228	2	Screw And Mold ASM
12		3	Screw-Flange ●	28		1	Cover Set ●
13	104-1219	2	Set-Screw	29		1	Cover B ●
14	104-1220	1	Bracket-Front	30		1	Bracket-Rear ●
15		4	Pole ●	31	3257-3	1	Key-Woodruff

● Not serviced separately

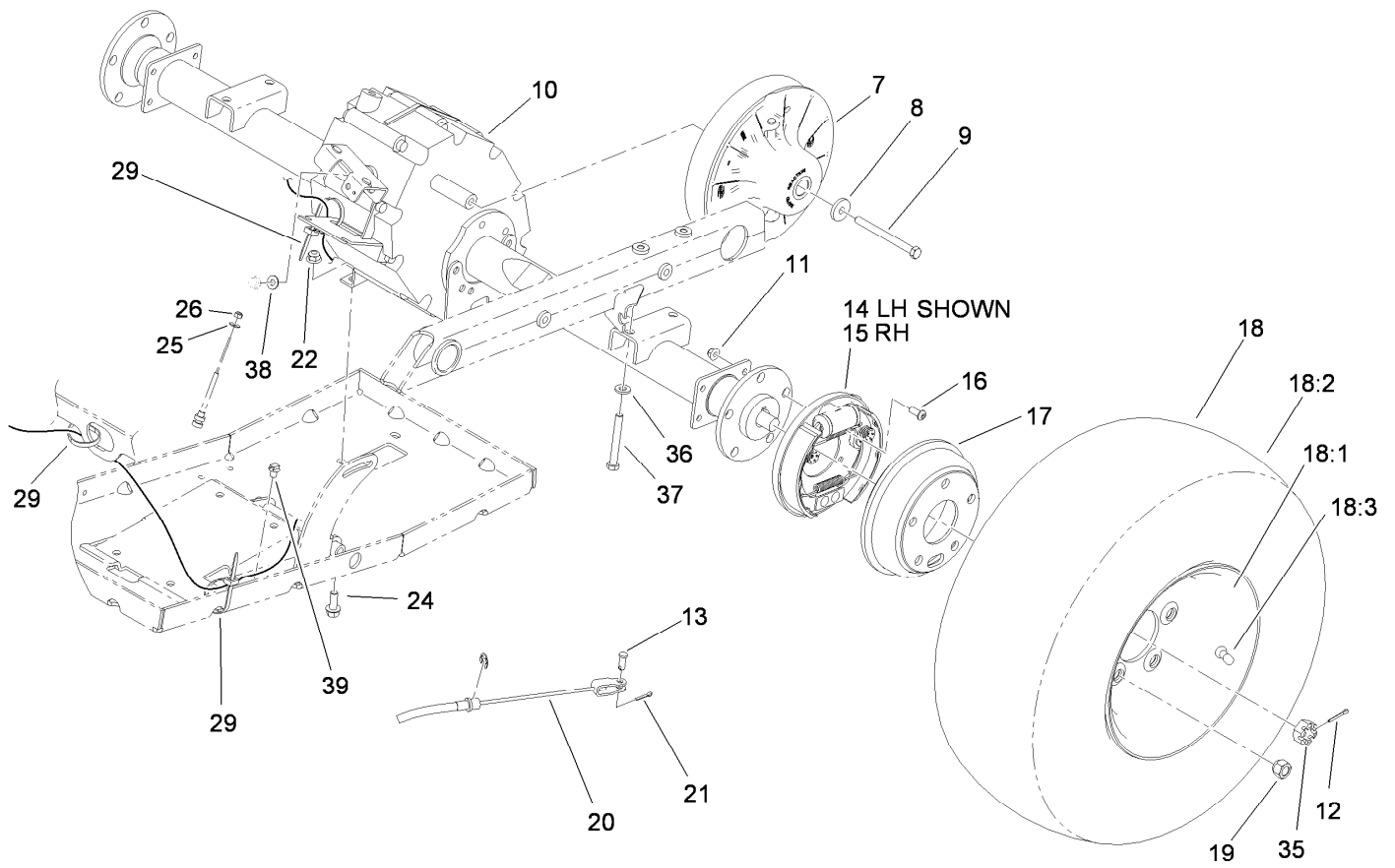

Rear Tire and Transaxle Assembly

Ref.	Part Number	Qty.	Description	Ref.	Part Number	Qty.	Description
7	119-0803	1	Clutch-Secondary	18:3	232-27	1	Stem-Valve
8	104-6563	1	Washer-Stepped	19	242-50	10	Nut-Lug
9	119-0723	1	Screw-HH, Lock	20	112-3309	2	Cable-Brake
10	119-0760	1	Transaxle	21	3272-10	2	Pin-Cotter
11	104-8300	8	Nut-Flange, NI	22	104-8301	4	Nut-Flange, NI
12	3272-12	2	Pin-Cotter	24	3234-11	4	Screw-HHF
13	283-62	2	Pin-Clevis	25	3256-49	2	Washer-Flat
14	114-8332	1	LH Brake ASM	26	3296-2	2	Nut-Lock, NI
15	114-8331	1	RH Brake ASM	29	3290-378	3	Tie-Cable
16	3274-55	8	Screw-HSBH	35	104-1656	2	Nut-Castle
17	104-6500	2	Drum-Brake	36	100-4852	4	Washer-Hardened
18	104-7282	2	Tire And Wheel ASM	37	323-14	4	Screw-HH
18:1	104-7279	1	Wheel	38	87-8640	1	Washer-Flat
18:2	104-7281	1	Tire	39	32180-030	1	Clip-Harness

Transaxle Assembly No. 119-0760

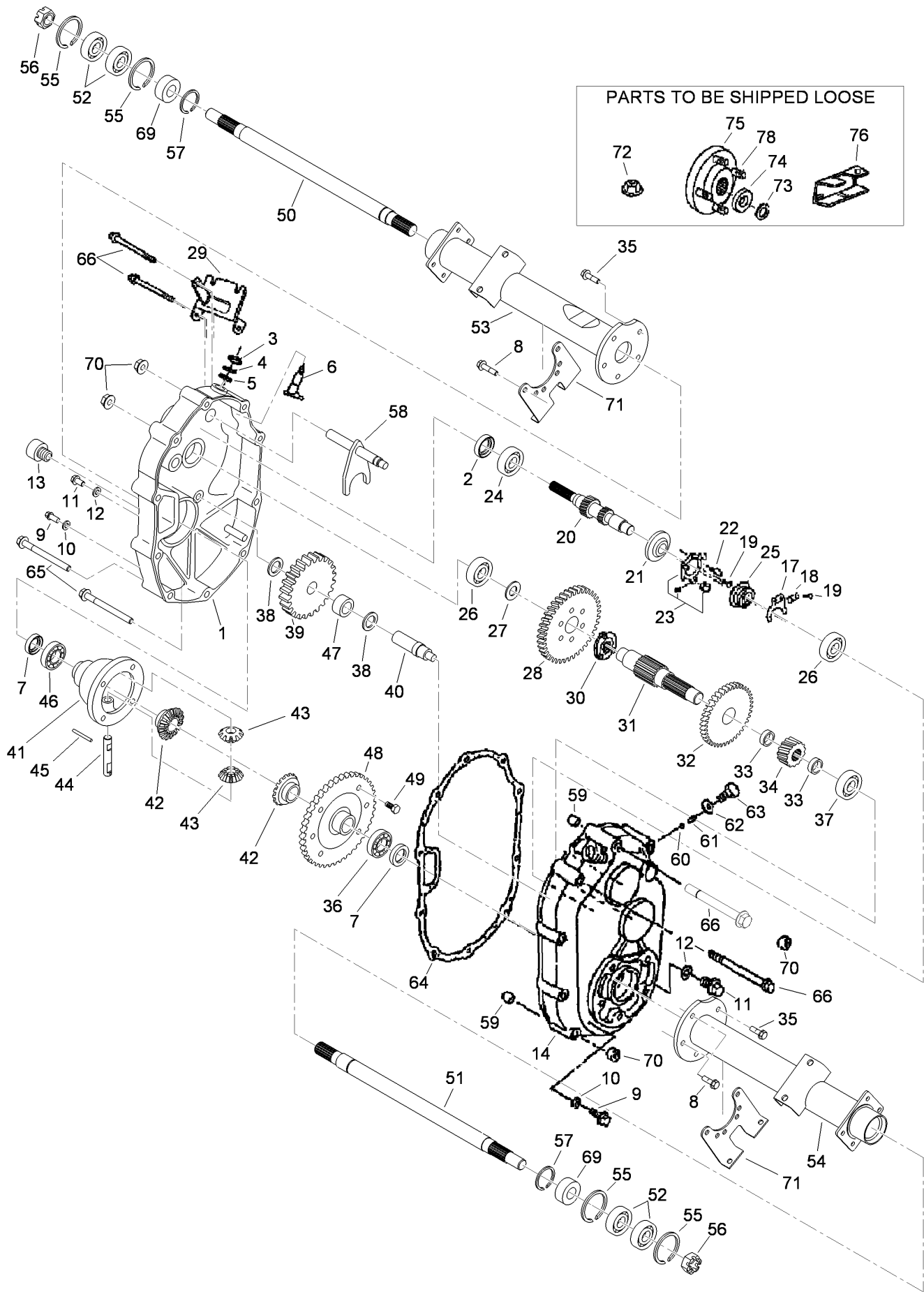

Transaxle Assembly No. 119-0760 (continued)

<i>Ref.</i>	<i>Part Number</i>	<i>Qty.</i>	<i>Description</i>	<i>Ref.</i>	<i>Part Number</i>	<i>Qty.</i>	<i>Description</i>
1	104-1601	1	Case-LH, Complete	40	104-1640	1	Shaft-Counter
2	104-1602	1	Seal-Oil	41	104-1641	1	Case-Differential
3	104-1603	1	Seal-Oil	42	104-1642	2	Gear-Side, Differential
4	104-1604	1	Ring-Snap	43	104-1643	2	Pinion-Differential
5	104-1605	1	Spacer	44	104-1644	1	Shaft-Differential
6	104-1606	1	Shaft-Selector	45	104-1645	1	Pin
7	104-1607	2	Seal-Oil	46	104-1646	1	Bearing-Ball
8	104-1608	4	Bolt-Flange	47	104-1647	1	Bearing-Needle
9	104-1609	2	Plug-Check, Oil	48	104-1648	1	Gear
10	104-1610	2	Gasket	49	104-1649	6	Bolt
11	104-1611	2	Plug-Drain, Oil	50	104-1650	1	Shaft-Axle, LH
12	104-1612	2	Gasket	51	104-1651	1	Shaft-Axle, RH
13	104-1613	1	Plug-Filler, Oil	52	104-1652	4	Bearing-Ball
14	104-1614	1	Case-Complete, RH	53	104-1653	1	Case-Axle, LH
17	104-1617	1	Fork-Governor	54	104-1654	1	Case-Axle, RH
18	104-1618	1	Stopper	55	104-1655	4	Ring-Snap
19	104-1619	4	Screw And Washer ASM	56	104-1656	2	Nut-Castle
20	104-7002	1	Shaft-Input, Complete	57	104-1657	2	Ring-Snap
21	104-1621	1	Base-Governor	58	104-6870	1	Shaft-Shift, Complete
22	104-1622	1	Pin-Lock	59	104-1659	2	Knock-Pipe
23	104-1623	1	Unit-Plate, Governor	60	104-1660	1	Ball-Steel
24	104-1624	1	Bearing-Ball	61	104-1661	1	Spring
25	104-1625	1	Sleeve-Governor	62	104-1662	1	Gasket
26	104-1626	2	Bearing-Ball	63	104-1663	1	Bolt
27	104-1627	1	Spacer	64	104-1664	1	Gasket
28	104-1628	1	Gear	65	104-1665	6	Bolt-Flange
29	104-1629	1	Bracket-Wire, Change	66	104-1666	4	Bolt-Flange
30	104-1630	1	Clutch-Pin	69	104-6867	2	Collar
31	104-1631	1	Shaft-Center	70	33004-00	10	Nut-HF
32	104-1632	1	Gear	71	104-1671	2	Bracket-Axle
33	104-1633	2	Collar	72	104-1672	1	Nut-Lock
34	104-1634	1	Gear	73	104-1673	2	Washer-Spring
35	104-1635	6	Bolt-Flange	74	104-1674	2	Washer
36	104-1636	1	Bearing-Ball	75	104-1675	2	Hub
37	104-1637	1	Bearing-Ball	76	104-6860	1	Lever-Select
38	104-1638	2	Spacer	78	104-8649	10	Stud
39	104-1639	1	Gear				

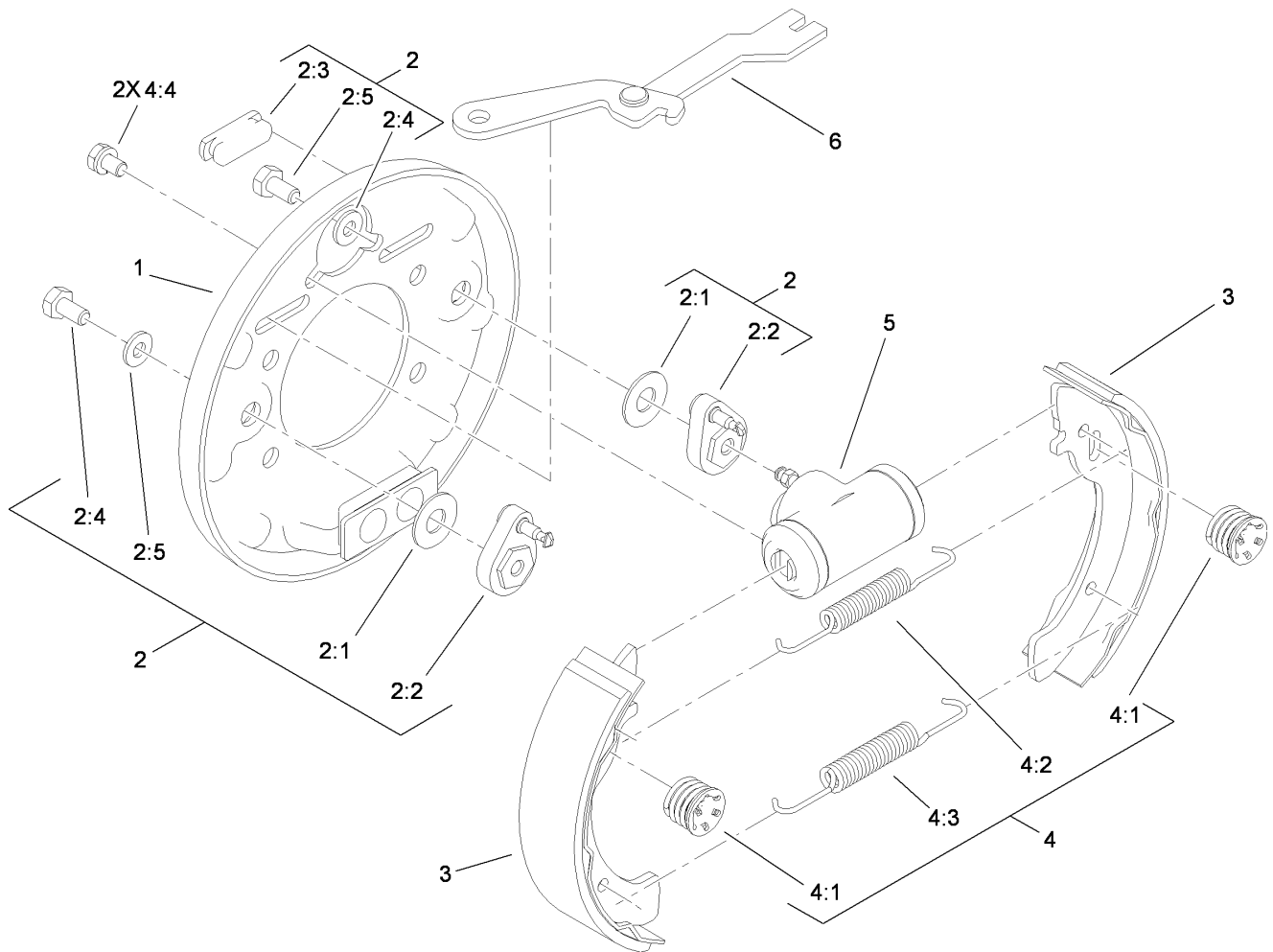

LH Rear Brake Assembly No. 114-8332

Ref.	Part Number	Qty.	Description
1	100-8586	1	Backing Plate ASM
2	104-6820	1	Adjuster Kit
2:1	100-8585	2	Washer-Bellville
2:2	100-8588	2	Adjuster Lever ASM
2:3	100-8584	2	Cover-Dust
2:4		2	Washer ●
2:5		2	Bolt ●
3	104-6818	4	Shoe And Lining Kit
4	104-6819	1	Hardware Kit
4:1	100-8583	2	Shoe Hold Down Spring ASM
4:2	100-8581	2	Spring-Upper
4:3	100-8582	2	Spring-Lower
4:4		2	Bolt And Washer ●
5	114-8333	1	Wheel Cylinder ASM
6	104-6825	1	LH Park Brake Lever ASM

● Not serviced separately

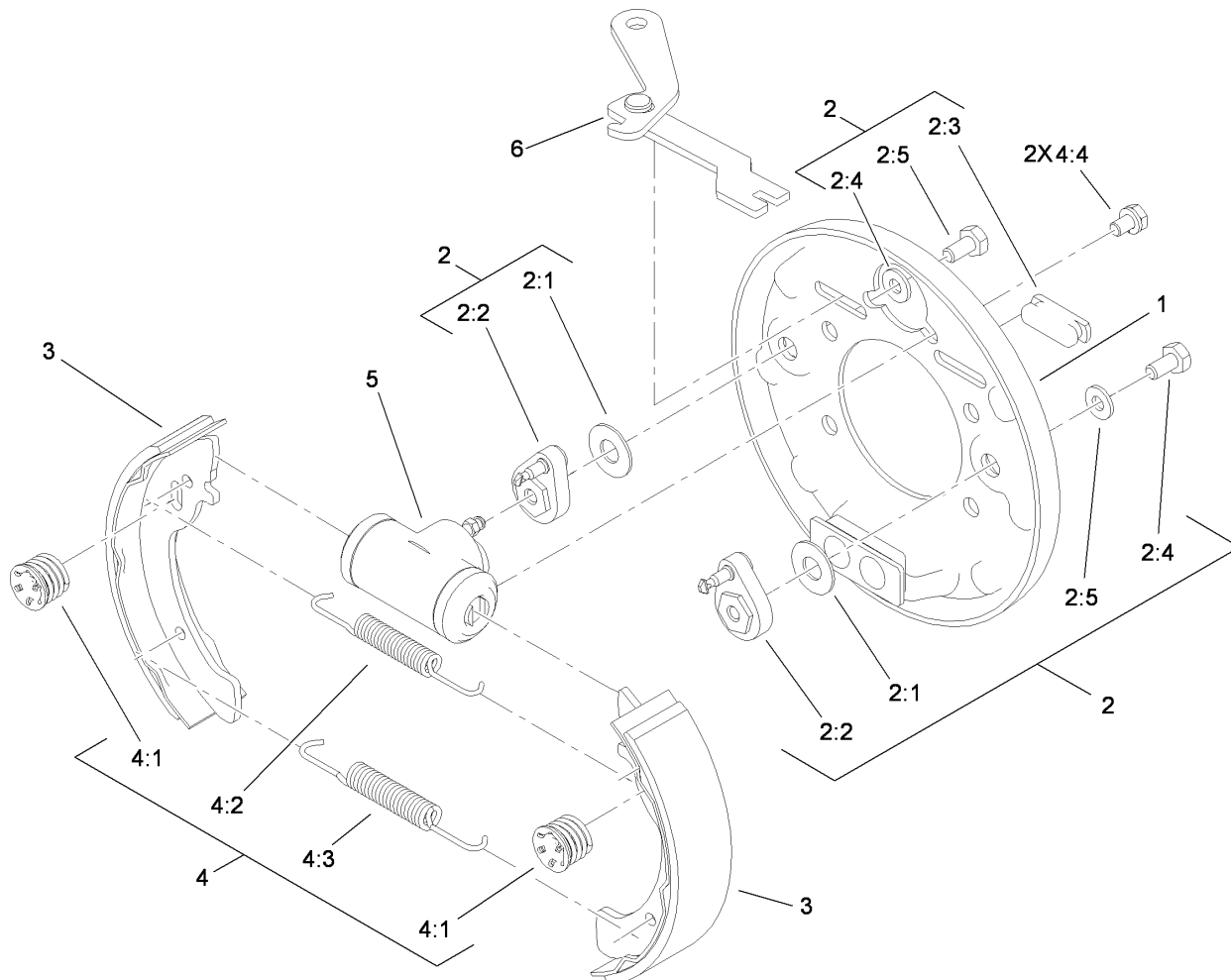

RH Rear Brake Assembly No. 114-8331

Ref.	Part Number	Qty.	Description
1	100-8586	1	Backing Plate ASM
2	104-6820	1	Adjuster Kit
2:1	100-8585	2	Washer-Bellville
2:2	100-8588	2	Adjuster Lever ASM
2:3	100-8584	2	Cover-Dust
2:4		2	Washer ●
2:5		2	Bolt ●
3	104-6818	4	Shoe And Lining Kit
4	104-6819	1	Hardware Kit
4:1	100-8583	2	Shoe Hold Down Spring ASM
4:2	100-8581	2	Spring-Upper
4:3	100-8582	2	Spring-Lower
4:4		2	Bolt And Washer ●
5	114-8333	1	Wheel Cylinder ASM
6	104-6826	1	RH Park Brake Lever ASM

● Not serviced separately

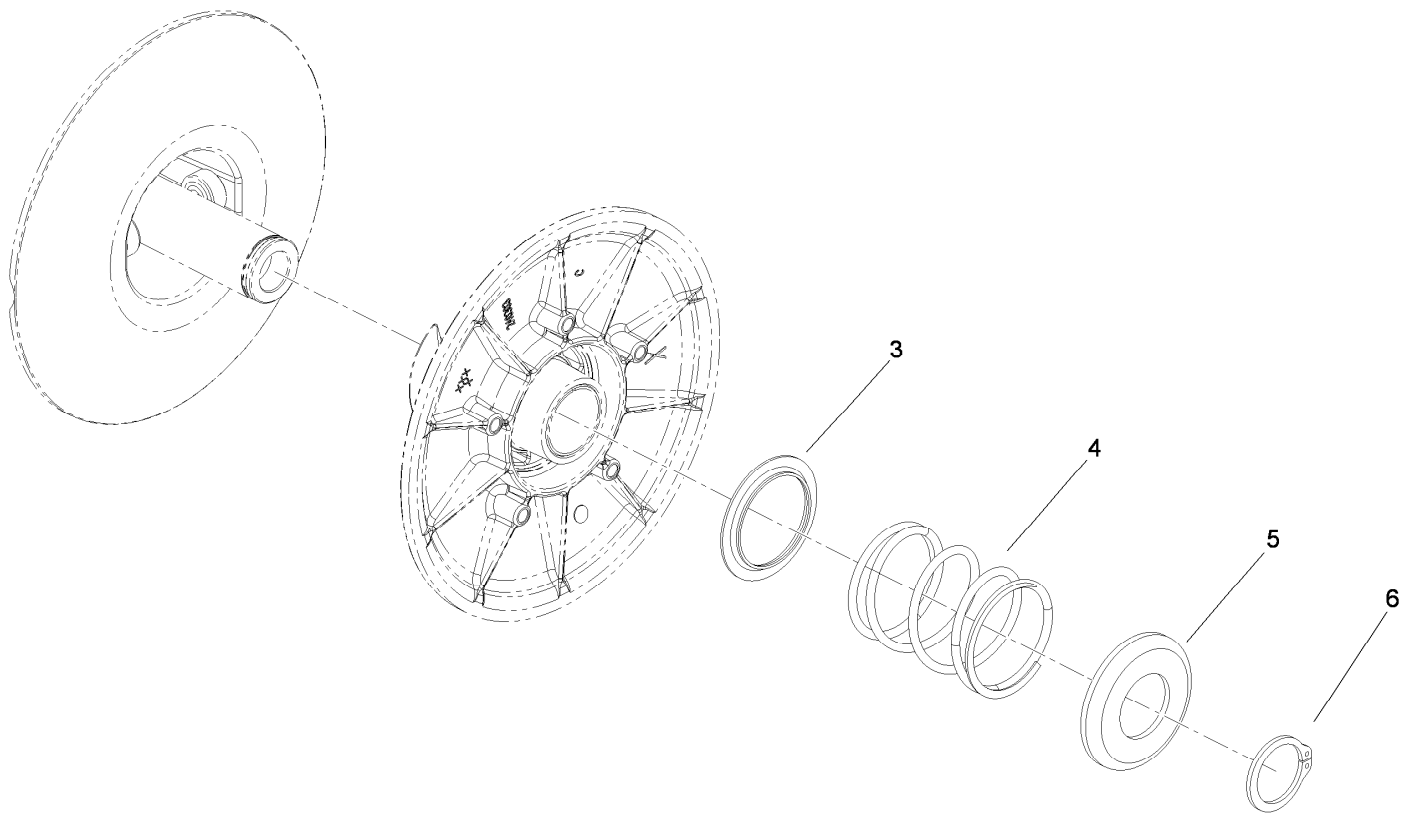

Secondary Clutch Assembly No. 119-0803

<i>Ref.</i>	<i>Part Number</i>	<i>Qty.</i>	<i>Description</i>
3	119-0809	1	Cup-Spring Retainer, Inner
4	119-0808	1	Spring-Secondary (Black/Blue)
5	119-0810	1	Cup-Spring Retainer, Outer
6	119-0811	1	Ring-Retaining

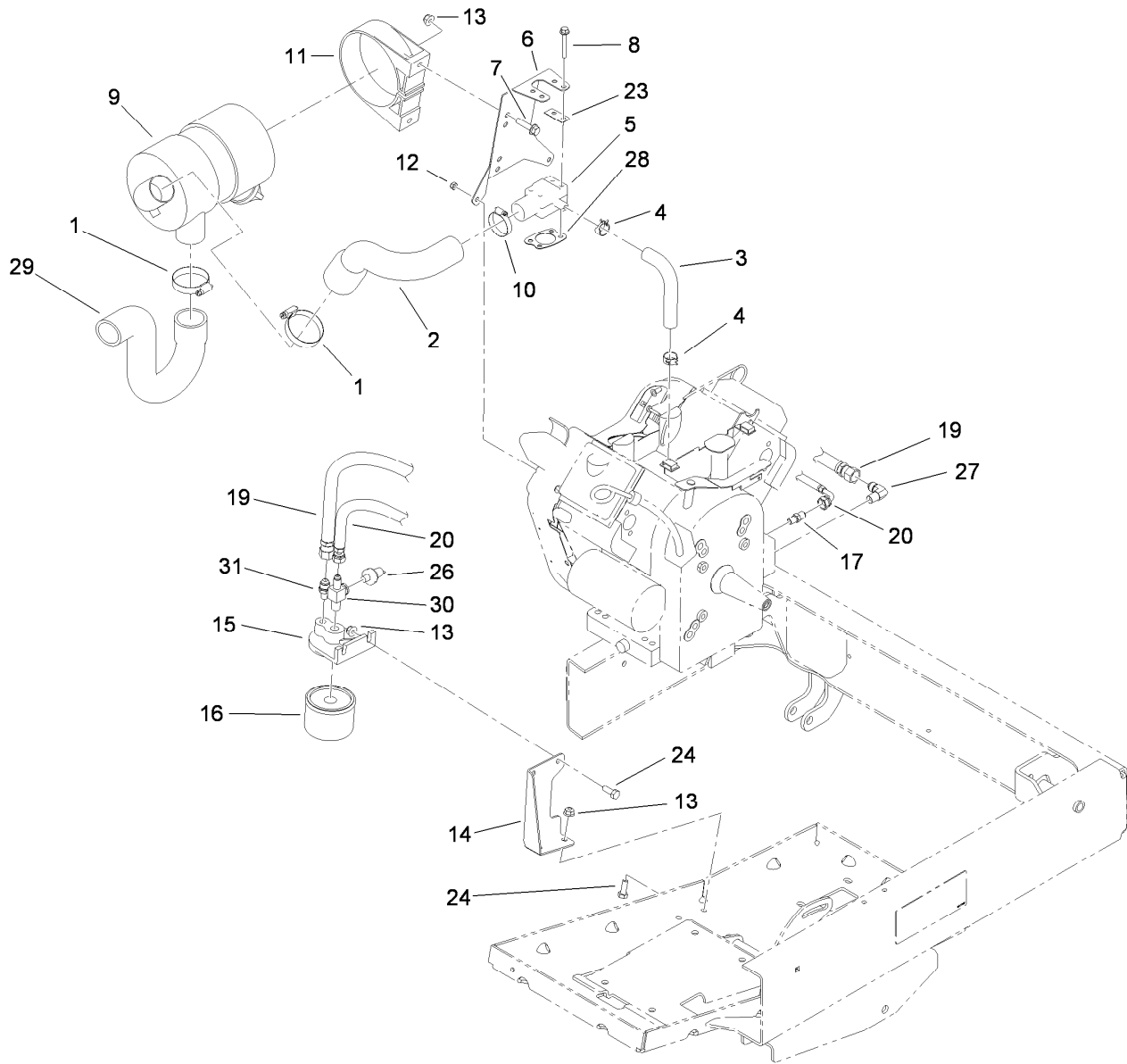

Oil Filter and Air Cleaner Assembly

Ref.	Part Number	Qty.	Description
1	2412-130	2	Clamp-Hose
2	112-3227	1	Hose-Intake
3	112-6461	1	Hose-Adapter, Carboretor
4	2412-143	2	Clamp-Hose
5	108-2829	1	Adaptor-Carburetor
6	119-0862-03	1	Bracket-Cleaner, Air
7	3234-36	2	Screw-HHF
8	33103-045	4	Screw-HHF
9	99-7120	1	Air Cleaner ASM
10	2412-3	1	Clamp-Hose
11	95-5806	1	Bracket-Mounting
12	33023-00	2	Nut-Lock
13	104-8300	6	Nut-Flange, NI
14	112-3240-03	1	Bracket-Filter, Oil

Ref.	Part Number	Qty.	Description
15	115-2314	1	Adapter-Filter, Oil
16	107-7817	1	Filter-Oil
17	112-3282	1	Fitting-Straight
19	119-0831	1	HYD Hose ASM
20	119-0832	1	HYD Hose ASM
23	108-8427	2	Gasket-Carburetor
24	322-4	4	Screw-HH
26	115-2316	1	Switch-Pressure
27	115-2317	1	Fitting-Elbow
28	110-8158	1	Gasket-Adaptor
29	115-7623	1	Hose-Intake
30	119-0826	1	Fitting-Tee
31	119-0833	1	Fitting-Straight

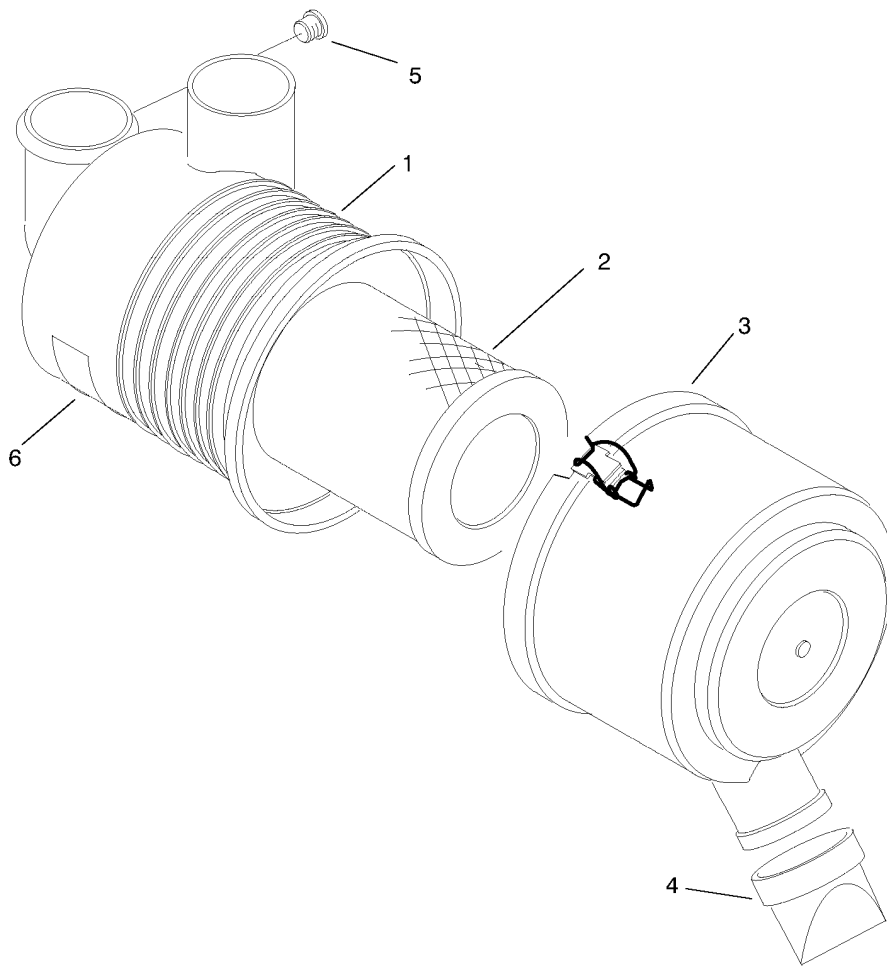

Air Cleaner Assembly No. 99-7120

<i>Ref.</i>	<i>Part Number</i>	<i>Qty.</i>	<i>Description</i>
1		1	Body ●
2	108-3811	1	Filter-Air
3	94-3652	1	Cover ASM
4	87-9400	1	Valve-Vacuator
5		1	Plug ●
6		1	Marking ●

● Not serviced separately

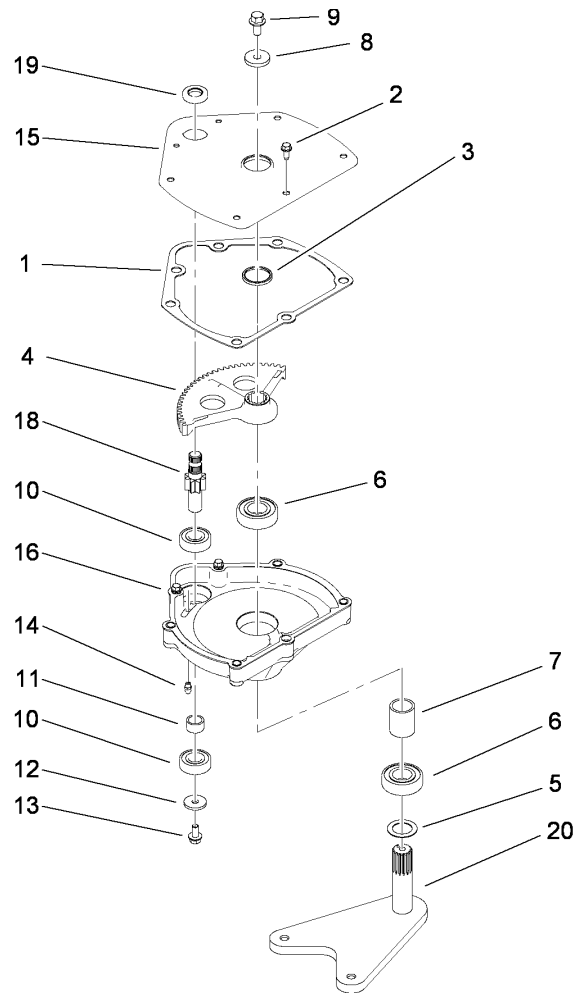

Steering Box Assembly No. 112-3130

<i>Ref.</i>	<i>Part Number</i>	<i>Qty.</i>	<i>Description</i>
1	94-2135	1	Gasket
2	32144-10	3	Screw-HWH
3	103118	1	Seal
4	99-7843	1	Sector-Gear
5	3256-42	1	Washer-Flat
6	251-82	2	Bearing-Ball
7	112-2917	1	Spacer
8	104-6563	1	Washer-Stepped
9	104-7156	1	Screw-HHF
10	38-7820	2	Bearing-Ball
11	94-2217	1	Spacer-Shaft, Input
12	1-613235	1	Washer
13	98-3498	1	Screw-HH
14	302-5	1	Fitting-Grease
15	112-2918-03	1	Cover-Housing, Steering
16	114-8309	1	Housing-Steering
18	115-7726	1	Gear-Pinion
19	99-7657	1	Seal-Oil
20	112-3096-03	1	Pitman Arm ASM

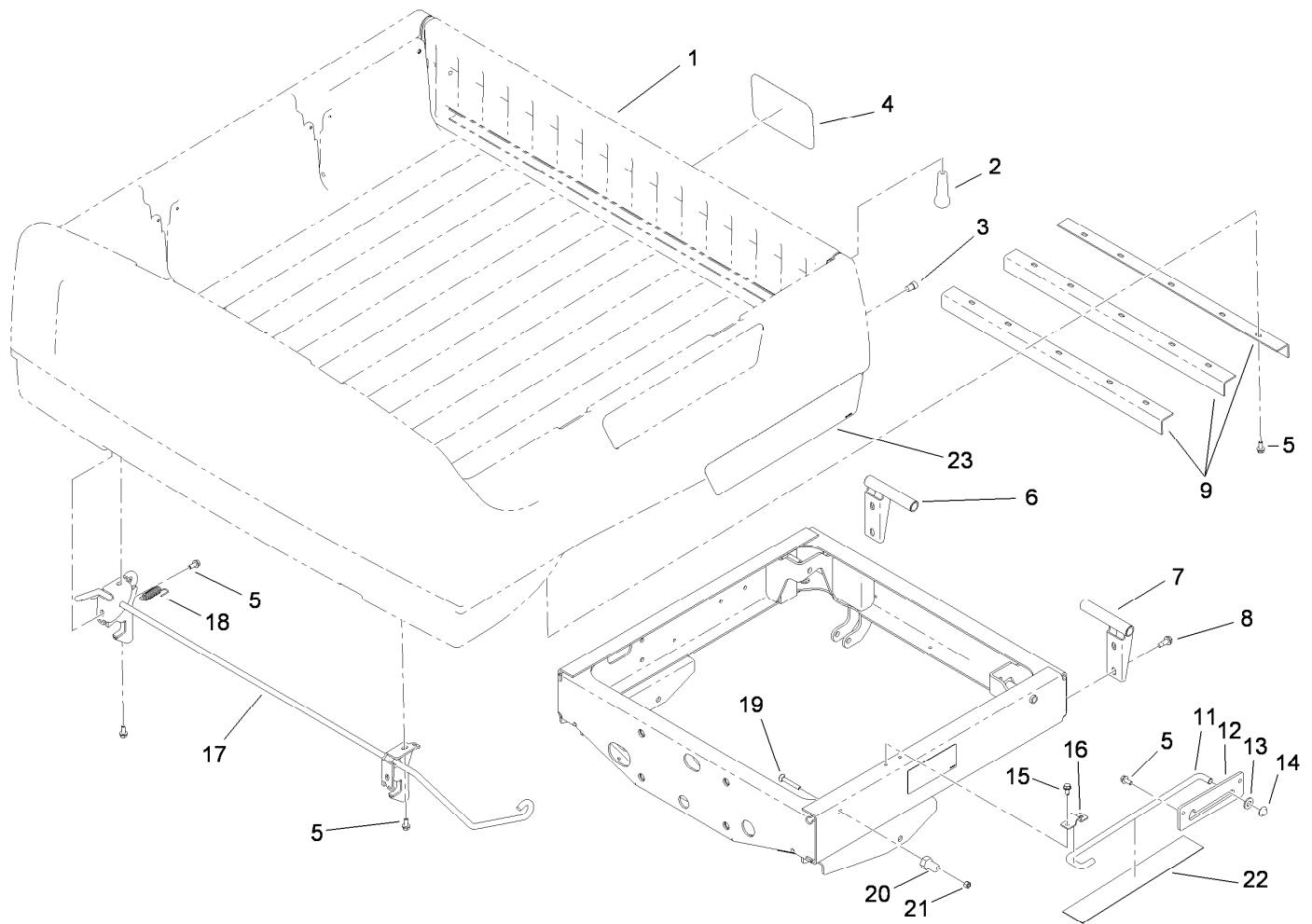

Box and Tailgate Installation Assembly

<i>Ref.</i>	<i>Part Number</i>	<i>Qty.</i>	<i>Description</i>	<i>Ref.</i>	<i>Part Number</i>	<i>Qty.</i>	<i>Description</i>
1		1	Box And Tailgate ASM ●	13	3256-26	1	Washer-Flat
2	99-7984	2	Knob-Soft Grip, Push-On	14	32112-14	1	Nut-Push
3	115-7986	2	Bumper-Rubber	15	32104-32	2	Screw-HWH
4	104-7213	1	Decal	16	99-7896	1	Bracket-U, Prop Rod
5	3234-5	19	Screw-HHF	17	115-2385	1	Rod-Latch
6	99-7309-03	1	RH Pivot Bracket ASM	18	5-7290	2	Spring-Tension
7	99-7308-03	1	LH Pivot Bracket ASM	19	3230-7	2	Screw-CARR
8	105-6245	4	Screw-Tapping	20	104-7248	2	Pin-Latch
9	99-7864-03	3	Brace-Box	21	3296-29	2	Nut-Lock, NI
11	99-7895	1	Rod-Prop	22	104-6859	1	Shield-Heat
12	99-7894	1	Bracket-Rod, Prop	23	115-2414	2	Decal

● Not serviced separately

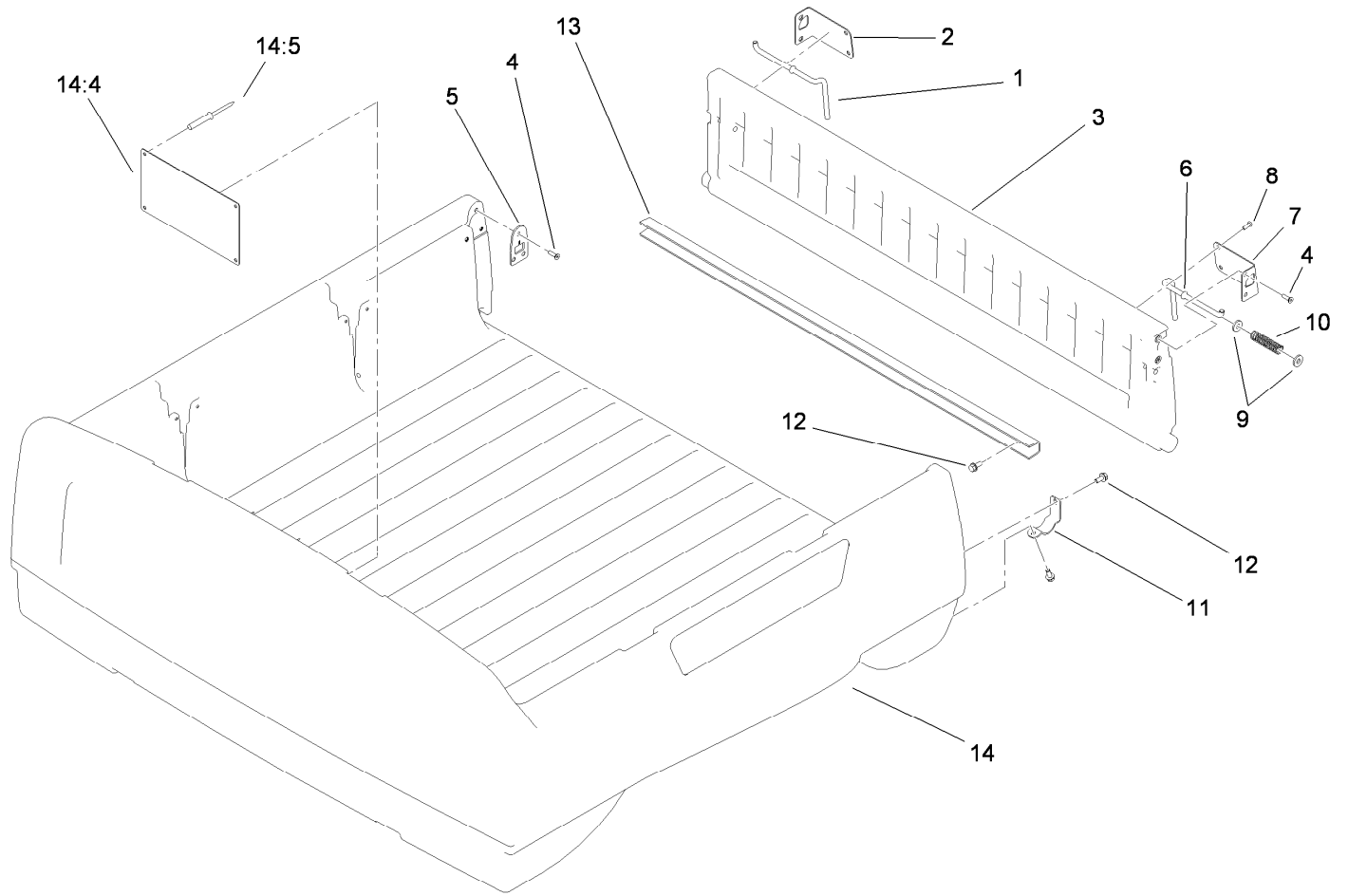

Box and Tailgate Assembly

<i>Ref.</i>	<i>Part Number</i>	<i>Qty.</i>	<i>Description</i>	<i>Ref.</i>	<i>Part Number</i>	<i>Qty.</i>	<i>Description</i>
1	99-7860	1	Rod-Latch, Right	9	99-7861	4	Washer-Latch
2	99-7858	1	Bracket-Tailgate Latch, Right	10	61-8880	2	Spring
3	115-7640	1	Tailgate ASM	11	99-7286	2	Bracket-Pivot, Tailgate
4	99-7334	10	Screw	12	3234-5	10	Screw-HHF
5	114-2749	2	Striker Plate	13	99-7867	1	Channel-Tailgate
6	99-7859	1	Rod-Latch, Left	14	115-7638	1	Box ASM
7	99-7857	1	Bracket-Tailgate Latch, Left	14:4	99-7954	1	Decal-No Riders
8	99-7335	4	Screw	14:5	3290-415	4	Rivet

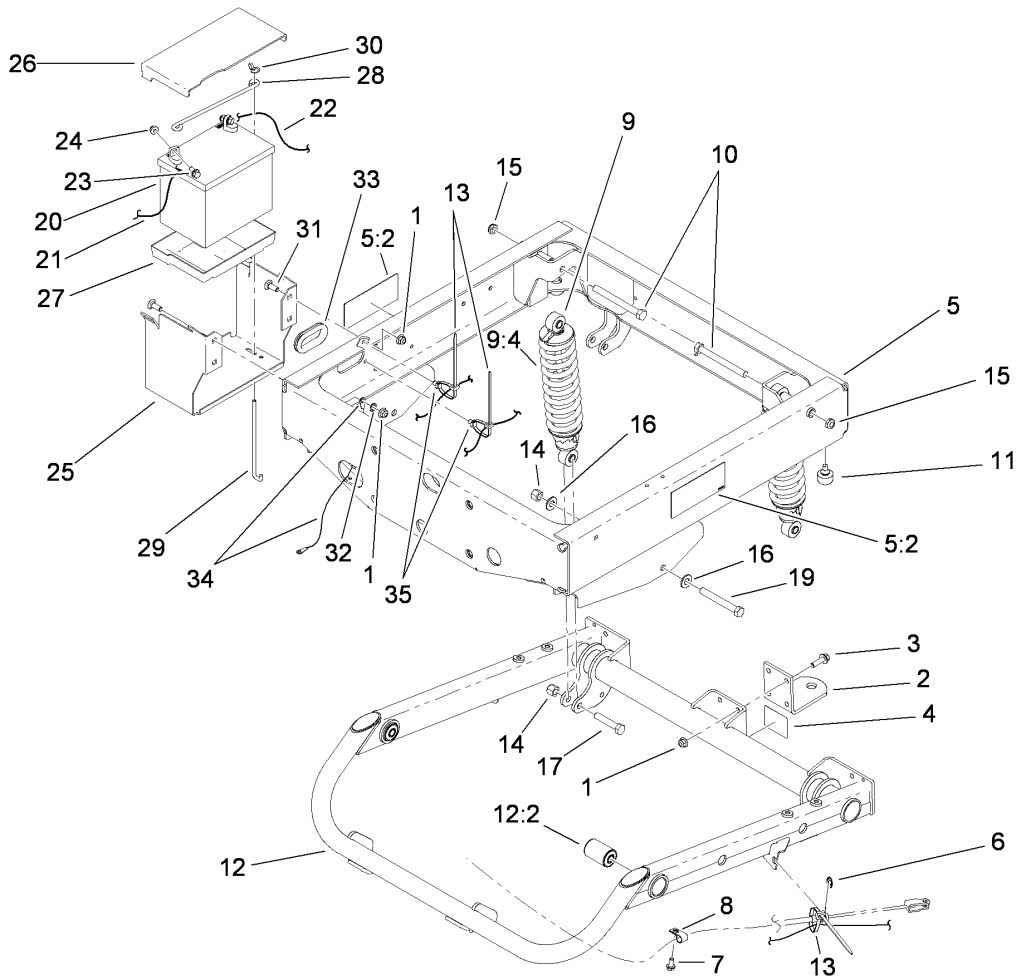

Frame Assembly

Ref.	Part Number	Qty.	Description	Ref.	Part Number	Qty.	Description
1	104-8301	8	Nut-Flange, NI	16	87-7270	4	Washer-Thrust
2	99-7654-03	1	Hitch-Duty, Light	17	325-10	2	Screw-HH
3	3234-24	4	Screw-HHF	19	325-17	2	Screw-HH
4	99-7350	1	Decal-Rating, Hitch (Light Duty)	20	104-8162	1	Battery
5	114-8307	1	Rear Frame Service ASM	21	115-8107	1	Cable-Battery, Negative
5:2	99-7345	2	Decal-Warning	22	114-9404	1	Cable-Battery, Positive
6	32120-47	2	Ring-Retaining, External	23	3234-5	2	Screw-HHF
7	32144-4	2	Screw-HWH	24	104-8300	2	Nut-Flange, NI
8	2412-89	2	Clamp	25	115-2302-03	1	Base-Battery
9	112-3168	2	Rear Shock/Spring ASM	26	115-2394	1	Cover-Battery
9:4	112-3386	1	Spring	27	106948	1	Tray-Battery
10	325-19	2	Screw-HH	28	100-6434	1	Rod-Hold Down, Battery
11	87-2440	2	Bumper-Rubber	29	100-6435	2	Post-Battery
12	115-7614	1	Swing Arm ASM	30	32103-22	2	Nut-Wing
12:2	112-3377	2	Bushing-Arm, Control	31	3231-22	4	Screw-CARR
13	3290-378	4	Tie-Cable	32	3254-6	1	Washer-Lock, Internal
14	3296-23	4	Nut-Lock, NI	33	240-12	1	Grommet
15	3296-45	2	Nut-Lock, NI	34	115-8108	1	Cable-Battery, Negative
				35	32180-030	2	Clip-Harness

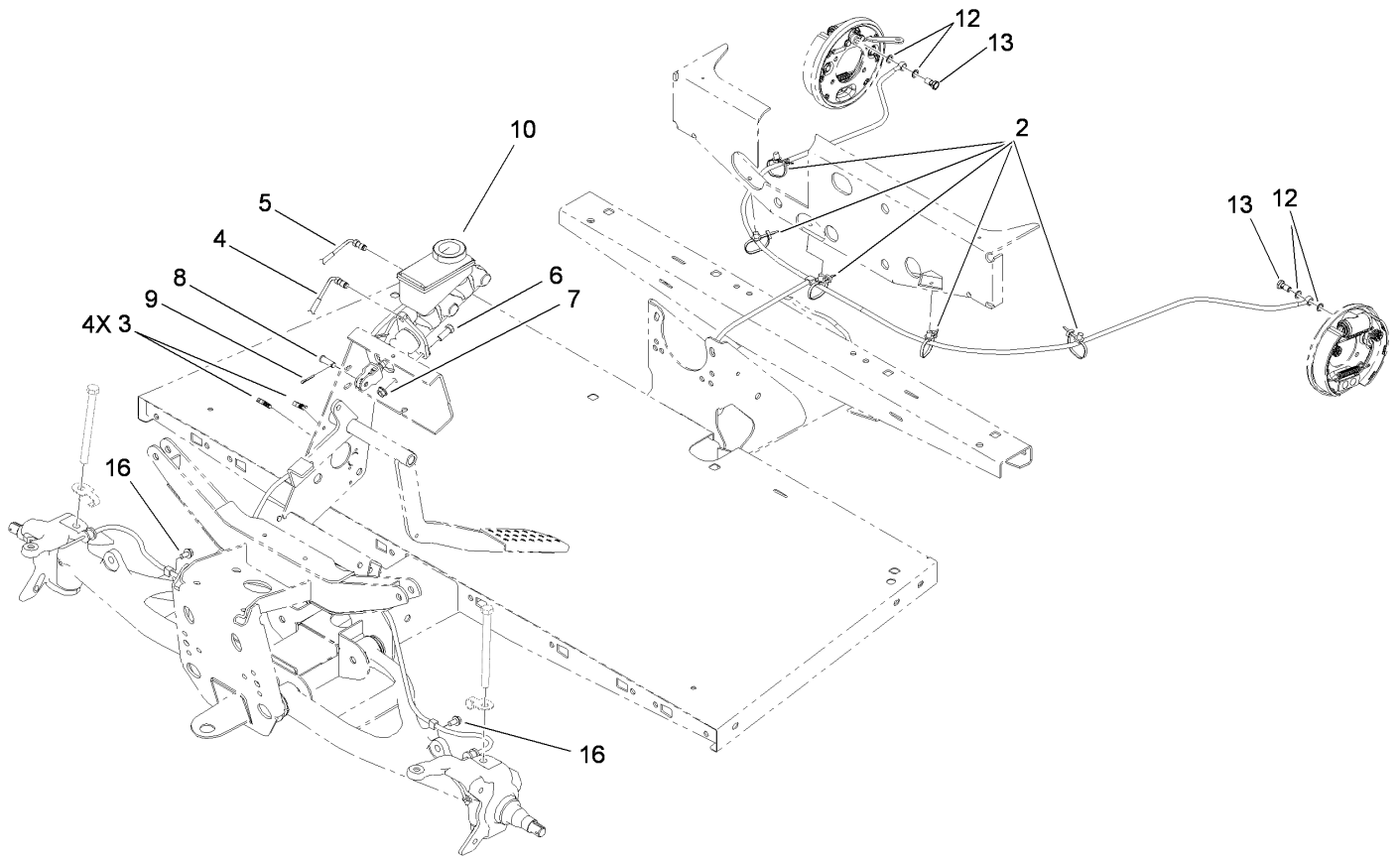

Master Cylinder and Brake Line Assembly

<i>Ref.</i>	<i>Part Number</i>	<i>Qty.</i>	<i>Description</i>
2	32180-030	5	Clip-Harness
3	114-8324	4	Clip-Line, Brake
4	112-2925	1	Front Brake Line ASM
5	112-2926	1	Rear Brake Line ASM
6	323-6	2	Screw-HH
7	3290-357	2	Nut-HHF, Whiz
8	283-2	1	Pin-Clevis
9	3272-10	1	Pin-Cotter
10	104-6782	1	Cylinder-Master
12	115-2341	4	Washer-Banjo
13	115-2340	2	Bolt-Banjo
16	32104-82	2	Screw-HHF

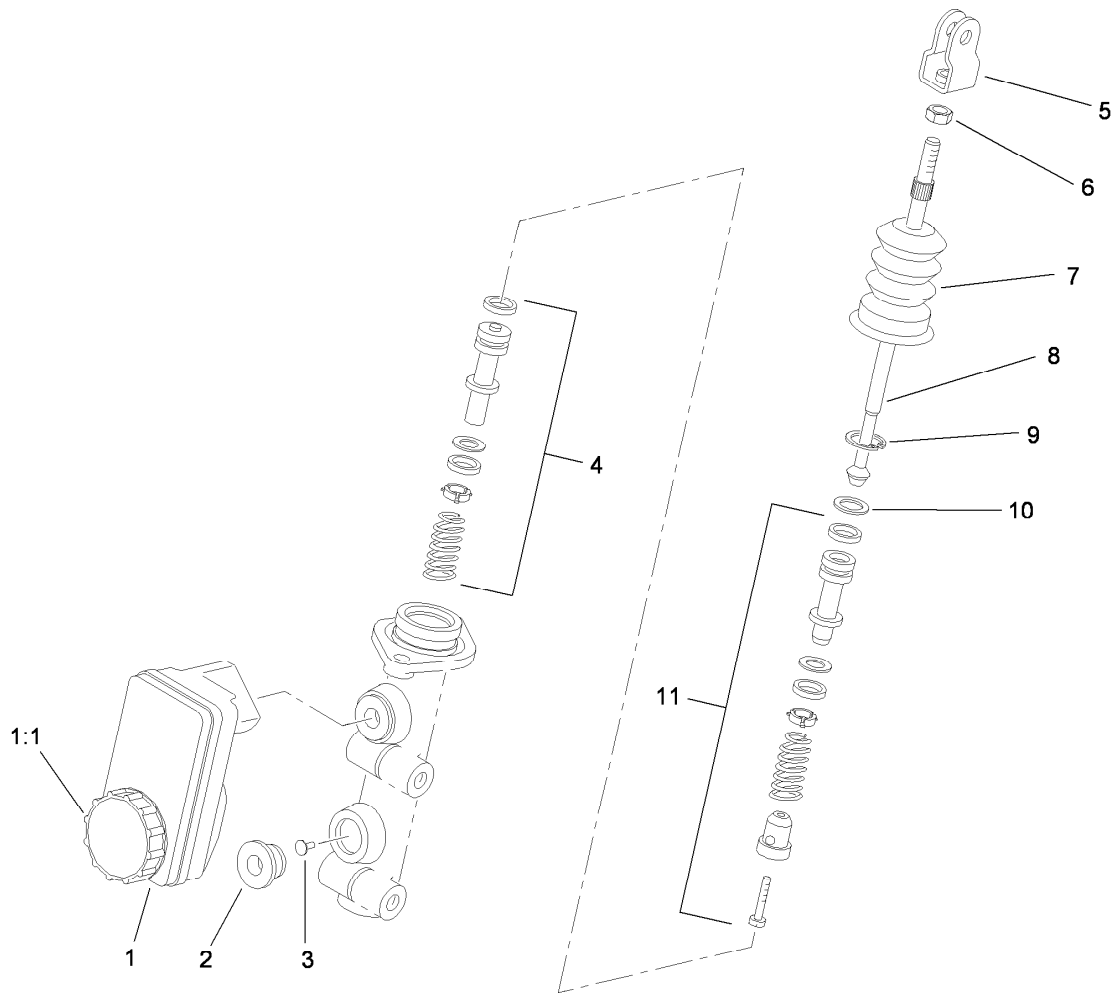

Master Cylinder Assembly No. 104-6782

<i>Ref.</i>	<i>Part Number</i>	<i>Qty.</i>	<i>Description</i>
1	104-6845	1	Reservoir ASM
1:1	92-4112	1	Cap ASM
2	93-8971	2	Seal-Port, Flange
3	92-4103	1	Pin-Stop
4	92-4102	1	Secondary Piston ASM
5	92-4110	1	Clevis
6	21-0360	1	Nut-Hex
7	94-5209	1	Cover-Dust
8	94-5210	1	Rod-Push
9	92-4109	1	Ring-Snap
10	92-4108	1	Retainer-Washer
11	92-4101	1	Primary Piston ASM

Attachments and Accessories

For 07273TC Workman MDX Utility Vehicle

Product Name	Model/Part
Roll-Over Protection System	07276
Receiver Hitch Kit	07278
Stake Side Kit	07290
Portable Refreshment Center	07298
Canopy Kit	07324
Solid Windshield Kit	07325
Folding Windshield Kit	07326
Snow Plow	07327
Hard Cab	07328
Heavy-Duty Bumper Kit	07329
Rear Lift Kit	07334
Electric Bed Lift Kit	07335
Vinyl Enclosure	07337
Heavy-Duty Brushguard and Bumper Kit	07338
Sliding Window Door Kit	07352
Fixed Window Door Kit	07353
Wheel-5 Bolt	104-6889
Tire-AT 489, 24x10.5-10	104-7061
Tire-AT 489, 22x9.5-10	104-7062
Brake and Signal Light Kit	115-7749
Lift Wire Harness Kit	115-7823
Backup Alarm Kit	115-7824
Replacement Front Spring Kit	117-4847
Tire And Wheel Asm	119-0751



Count on it.