



Count on it.

Operator's Manual

Workman® 200 Spray System

Heavy-Duty Workman® Vehicles

Model No. 41235—Serial No. 31000001 and Up

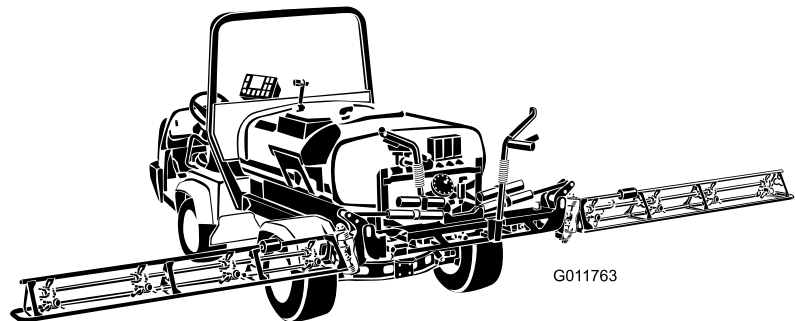

G011763

The installation of the Workman® 200 Spray System requires the installation of one or more interdependent kits. Contact your Authorized Toro Dealer for more information.



The Workman® 200 Spray System is a dedicated turf spray modification for Workman® vehicles and is intended to be used by professional, hired operators in commercial applications. It is primarily designed for spraying on well-maintained lawns in parks, golf courses, sports fields, and on commercial grounds.

This product complies with all relevant European directives, for details please see the separate product specific Declaration of Conformity (DOC) sheet.

Introduction

Read this manual carefully to learn how to operate and maintain your product properly. The information in this manual can help you and others avoid injury and product damage. Although Toro designs and produces safe products, you are responsible for operating the product properly and safely. You may contact Toro directly at www.Toro.com for product and accessory information, help finding a dealer, or to register your product.

Whenever you need service, genuine Toro parts, or additional information, contact an Authorized Service Dealer or Toro Customer Service and have the model and serial numbers of your product ready. Figure 1 illustrates the location of the model and serial numbers on the product.

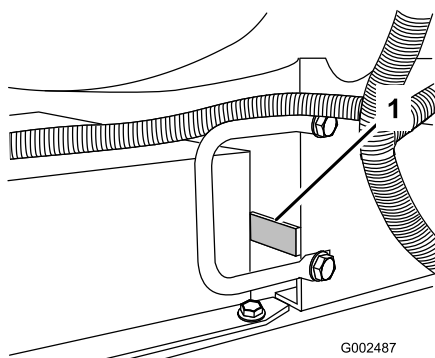

Figure 1

1. Location of the model and serial numbers

Model No. _____
Serial No. _____

This manual identifies potential hazards and has safety messages identified by the safety alert symbol (Figure 2), which signals a hazard that may cause serious injury or death if you do not follow the recommended precautions.



Figure 2

1. Safety alert symbol.

This manual uses two other words to highlight information. **Important** calls attention to special mechanical information and **Note** emphasizes general information worthy of special attention.

Contents

Introduction.....	2
Safety	3
Safe Operating Practices	3
Chemical Safety	4
Before Operating	4
While Operating.....	5
Maintenance.....	6
Safety and Instructional Decals	8
Setup.....	11
1 Removing Existing Bed.....	12
2 Preparing the Workman®	13
3 Installing the Vehicle Speed Sensor(for Workman® 3000, 4000 series only)	13
4 Installing the Power Take-Off (PTO) Kit(for Workman® 3000, 4000 series only).....	14
5 Installing the Electrical Harness	14
6 Installing the Control Box Mount	17
7 Installing the Attachment Hold-down Brackets	18
8 Installing the Radiator Cover(for Workman® 3000, 4000 series only)	19
9 Installing the Tank Skid.....	19
10 Installing the Control Box	21
11 Installing the Boom Assembly	22
12 Installing Boom Hoses.....	24
13 Installing the Nozzles.....	25
14 Completing the Setup: Learning more about your product.	25
Product Overview	26
Controls	26
Specifications	30
Operation.....	31
Think Safety First.....	31
Adjusting the Booms to Level.....	31
Operating the Sprayer.....	31
Filling the Spray Tank	32
Operating the Booms	32
Spraying	33

Safety

Improper use or maintenance by the operator or owner can result in injury. To reduce the potential for injury, comply with these safety instructions and always pay attention to the safety alert symbol, which means CAUTION, WARNING, or DANGER-“personal safety instruction.” Failure to comply with the instruction may result in personal injury or death.

Safe Operating Practices

▲ WARNING

The Workman® equipped with a spray system is an off-highway vehicle only and is not designed, equipped, or manufactured for use on public streets, roads, or highways.

The Workman® was designed and tested to offer safe service when operated and maintained properly. Although hazard control and accident prevention partially are dependent upon the design and configuration of the machine, these factors are also dependent upon the awareness, concern, and proper training of the personnel involved in the operation, maintenance and storage of the machine. Improper use or maintenance of the machine can result in injury or death.

This is a specialized utility vehicle designed for off-road use only. Its ride and handling will have a different feel than what drivers experience with passenger cars or trucks. So take time to become familiar with your Workman.

Not all of the attachments that adapt to the Workman are covered in this manual. See the specific *Operator’s Manual* provided with attachment for additional safety instructions. **READ THESE MANUALS.**

TO REDUCE THE POTENTIAL FOR INJURY OR DEATH, COMPLY WITH THE FOLLOWING SAFETY INSTRUCTIONS.

Supervisor’s Responsibilities

- Make sure that operators are thoroughly trained and familiar with the *Operator’s Manual*, Training Material, Engine Manual, and all labels on the Workman vehicle.
- Be sure to establish your own special procedures and work rules for unusual operating conditions (e.g. slopes too steep for vehicle operation). Use the 3rd

Spraying Tips	33
Cleaning the Sprayer	33
Calibrating the Spray Pro Monitor.....	35
Calibrating the Boom Bypass Valves.....	37
Pump	37
Maintenance.....	39
Recommended Maintenance Schedule(s)	39
Daily Maintenance Checklist.....	39
Notation for Areas of Concern	40
Premaintenance Procedures.....	40
Accessing the Machine	40
Lubrication.....	42
Greasing the Sprayer System	42
Greasing the Boom Hinges.....	42
Greasing the Actuator Rod Bearings	42
Electrical System Maintenance.....	44
Fuses.....	44
Spray System Maintenance.....	44
Inspecting the Hoses	44
Pump Maintenance.....	44
Adjusting the Boom Actuator	45
Emergency Manual Operation of the Boom	
Actuators	45
Inspecting the Nylon Pivot Bushings.....	45
Cleaning.....	46
Cleaning the Flowmeter.....	46
Cleaning the Suction Strainer	46
Storage.....	47
Removing the Sprayer.....	47
Troubleshooting.....	49
Schematics	51

High Lockout switch if high speed could result in a safety or vehicle abuse situation.

Chemical Safety

▲ WARNING

Chemical substances used in the spray system may be hazardous and toxic to you, bystanders, animals, plants, soils or other property.

- **Carefully read and follow the chemical warning labels and Material Safety Data Sheets (MSDS) for all chemicals used and protect yourself according to the chemical manufacturer's recommendations. For example, use appropriate Personal Protective Equipment (PPE) including face and eye protection, gloves, or other equipment to guard against personal contact with the chemical.**
- **Keep in mind that there may be more than one chemical used and information on each should be assessed.**
- ***Refuse to operate or work on the sprayer if this information is not available!***
- **Before working on a spray system make sure the system has been triple rinsed and neutralized according to the recommendations of the chemical manufacturer(s).**
- **Verify there is an adequate supply of clean water and soap nearby, and immediately wash off any chemicals that contact you.**
- Obtain proper training before using or handling chemicals.
- Use the correct chemical for the job.
- Follow the chemical manufacturer's instructions for the safe application of the chemical.
- Handle chemicals in a well ventilated area.
- Wear goggles and other protective equipment as instructed by the chemical manufacturer. Ensure that as little skin as possible is exposed while using chemicals.
- Have clean water available especially when filling the spray tank.
- Do not eat, drink, or smoke while working with chemicals.
- Always wash your hands and other exposed areas as soon as possible after finishing the work.
- Properly dispose of unused chemicals and chemical containers as instructed by the chemical manufacturer and your local codes.

- Chemicals and fumes in the tanks are dangerous; never enter the tank or place your head over or in the opening.
- Follow all local/state/federal requirements for the spraying of chemicals.

Before Operating

- Operate the machine only after reading and understanding the contents of this manual.
- **Never** allow children to operate the sprayer.
- **Never** operate the sprayer without first reading and understanding the *Operator's Manual*. Only trained and authorized persons should operate this sprayer. Make sure that all operators are physically and mentally capable of operating the sprayer.
- This vehicle is designed to carry **only you**, the operator, and **one passenger** in the seat provided by the manufacturer. **Never** carry any other passengers on the vehicle.
- **Never** operate the sprayer when under the influence of drugs or alcohol. Even prescription drugs and cold medicines can cause drowsiness.
- Do not drive the sprayer when you are tired. Be sure to take occasional breaks. It is very important that you stay alert at all times.
- Become familiar with the controls and know how to stop the engine quickly.
- Keep all shields, safety devices, and decals in place. If a shield, safety device, or decal is malfunctioning, illegible, or damaged, repair or replace it before operating the machine.
- Always wear substantial shoes. Do not operate the machine while wearing sandals, tennis shoes, or sneakers. Do not wear loose fitting clothing or jewelry which could get caught in moving parts and cause personal injury.
- Wearing safety glasses, safety shoes, long pants, and a helmet is advisable and required by some local safety and insurance regulations.
- Keep everyone, especially children and pets, away from the areas of operation.
- Be extremely careful when operating around people. Always be aware of where bystanders might be and keep them away from the work area.
- Before operating the vehicle, always check all parts of the vehicle and any attachments. If something is wrong, **stop using the vehicle**. Make sure problem is corrected before vehicle or attachment is operated again.

- Since gasoline is highly flammable, handle it carefully.
 - Use an approved gasoline container.
 - Do not remove the cap from the fuel tank when the engine is hot or running.
 - Do not smoke while handling gasoline.
 - Fill the fuel tank outdoors, and fill it to about 1 inch (25 mm) below the top of the tank (the bottom of the filler neck). Do not overfill it.
 - Wipe up any spilled gasoline.
- Use only an approved non-metal, portable fuel container. Static electric discharge can ignite gasoline vapors in a ungrounded fuel container. Remove the fuel container from the bed of the vehicle and place on the ground away from the vehicle before filling. Keep nozzle in contact with container while filling.
- Check the safety interlock system daily for proper operation. If a switch should malfunction, replace the switch before operating machine.
- Using the machine demands attention. Failure to operate vehicle safely may result in an accident, tip over of vehicle and serious injury or death. Drive carefully. To prevent tipping or loss of control:
 - Use extreme caution, reduce speed and maintain a safe distance around sand traps, ditches, creeks, ramps, and any unfamiliar areas or other hazards.
 - Watch for holes or other hidden hazards.
 - Use caution when operating vehicle on a steep slope. Normally travel straight up and down slopes. Reduce speed when making sharp turns or when turning on hillsides. Avoid turning on hillsides whenever possible.
 - Use extra caution when operating vehicle on wet surfaces, at higher speeds or with a full load. Stopping time will increase with a full load. Shift into a lower gear before starting up or down a hill.
 - Avoid sudden stops and starts. Do not go from reverse to forward or forward to reverse without first coming to a complete stop.
 - Do not attempt sharp turns or abrupt maneuvers or other unsafe driving actions that may cause a loss of vehicle control.
 - Do not pass another vehicle traveling in the same direction at intersections, blind spots, or at other dangerous locations.
 - When draining, do not let anyone stand behind vehicle and do not drain liquid on any one's feet.
 - Keep all bystanders away. Before backing up, look to the rear and assure no one is behind. Back up slowly.
 - Watch out for traffic when near or crossing roads. Always yield the right of way to pedestrians and other vehicles. This vehicle is not designed for use on streets or highways. Always signal your turns or stop early enough so other persons know what you plan to do. Obey all traffic rules and regulations.
 - Never operate vehicle in or near an area where there is dust or fumes in the air which are explosive. The electrical and exhaust systems of the vehicle can produce sparks capable of igniting explosive materials.
 - If ever unsure about safe operation, **stop work** and ask your supervisor.

While Operating

⚠ WARNING

Engine exhaust contains carbon monoxide, which is an odorless, deadly poison that can kill you.

Do not run engine indoors or in an enclosed area.

- Operator and passenger should remain seated whenever the vehicle is in motion. Operator should keep both hands on steering wheel, whenever possible and passenger should use hand holds provided. Keep arms and legs within the vehicle body at all times. Never carry passengers in the box or on attachments. Remember your passenger may not be expecting you to brake or turn and may not be ready.
- Always watch out for and avoid low overhangs such as tree limbs, door jambs, and over-head walkways. Make sure there is enough room over head to easily clear the vehicle, sprayer booms and your head.
- When starting the engine:
 - Sit on operator's seat and ensure parking brake is engaged.
 - Disengage PTO (if so equipped) and return hand throttle lever to Off position (if so equipped).
 - Move shift lever to Neutral and depress clutch pedal.
 - Keep foot off accelerator pedal.
 - Turn ignition key to Start.
- Do not use a cab on a Workman vehicle equipped with a spray system. The cab is not pressurized and will not provide adequate ventilation when used with

a sprayer. The cab will also overload the vehicle when the spray system tank is full.

- Do not touch engine, transaxle, muffler or muffler manifold while engine is running or soon after it has stopped because these areas may be hot enough to cause burns.
- If the machine ever vibrates abnormally, stop immediately, turn engine off, wait for all motion to stop and inspect for damage. Repair all damage before resuming operation.
- Before getting off the seat:
 - Stop movement of the machine.
 - Shut engine off and wait for all movement to stop.
 - Set parking brake.
 - Remove key from ignition.

Note: Block wheels if machine is on an incline.

- Lightning can cause severe injury or death. If lightning is seen or thunder is heard in the area, do not operate the machine; seek shelter.

Braking

- Slow down before you approach an obstacle. This gives you extra time to stop or turn away. Hitting an obstacle can damage the vehicle and its contents. More important, it can injure you and your passenger.
- Gross Vehicle Weight (GVW) has a major impact on your ability to stop and/or turn. Heavy loads and attachments make a vehicle harder to stop or turn. The heavier the load, the longer it takes to stop.
- Turf and pavement are slick when they are wet. It can take 2 to 4 times as long to stop on wet surfaces as on dry surfaces. If you drive through standing water deep enough to get the brakes wet, they will not work well until they are dry. After driving through water, you should test the brakes to make sure they work properly. If they do not, drive slowly while putting light pressure on the brake pedal. This will dry the brakes out.

Operating on Hills and Rough Terrain

Operating the vehicle on a hill may cause tipping or rolling of the vehicle, or the engine may stall and you could lose headway on the hill. This could result in personal injury.

- Do not accelerate quickly or slam on the brakes when backing down a hill, especially with a load.
- Never drive across a steep hill; always drive straight up or down or go around the hill.

- If the engine stalls or you begin to lose headway while climbing a hill, gradually apply the brakes and slowly back straight down the hill.
- Turning while traveling up or down hills can be dangerous. If you have to turn while on a hill, do it slowly and cautiously. Never make sharp or fast turns.
- Heavy loads affect stability. Reduce the weight of the load and your speed when operating on hills.
- Avoid stopping on hills, especially with a load. Stopping while going down a hill will take longer than stopping on level ground. If the sprayer must be stopped, avoid sudden speed changes, which may initiate tipping or rolling of the sprayer. Do not slam on the brakes when rolling backward, as this may cause the sprayer to overturn.
- Reduce speed and load when operating on rough terrain, uneven ground, and near curbs, holes, and other sudden changes in terrain. Loads may shift, causing the sprayer to become unstable.

Loading

The weight of the cargo can change the Workman center of gravity and handling. To avoid loss of control and personal injury, follow these guidelines:

- Reduce the weight of the load when operating on hills and rough terrain to avoid tipping or overturning of the vehicle.
- Liquid loads can shift. This shifting happens most often while turning, going up or down hills, suddenly changing speeds, or while driving over rough surfaces. Shifting loads can cause the vehicle to tip over.
- When operating with a heavy load, reduce your speed and allow for sufficient braking distance. Do not suddenly apply the brakes. Use extra caution on slopes.
- Be aware that heavy loads increase your stopping distance and reduce your ability to turn quickly without tipping over.

Maintenance

- Only permit qualified and authorized personnel to maintain, repair, adjust, or inspect the vehicle.
- Before servicing or making adjustments to the machine, stop the engine, set the parking brake, and remove the key from the ignition to prevent someone from accidentally starting the engine.
- Empty the tank before tilting or removing sprayer from vehicle and before storage.

- Never work under a sprayer without using tank support prop rod.
- Make sure all hydraulic line connectors are tight, and all hydraulic hoses and lines are in good condition before applying pressure to the system.
- Keep body and hands away from pin hole leaks that can eject hydraulic fluid under high pressure. Use paper or cardboard, not hands, to search for leaks.

▲ DANGER

Hydraulic fluid escaping under pressure can have sufficient force to penetrate skin and do serious damage.

If fluid is injected into the skin it must be surgically removed within a few hours by a doctor familiar with this form of injury or gangrene may result.

- Before disconnecting or performing any work on the hydraulic system, all pressure in system must be relieved by stopping engine, cycling dump valve from raise to lower and/or lowering the tank and attachments. If the tank must be in the raised position, secure it with the safety support.
- To make sure entire machine is in good condition, keep all nuts, bolts and screws properly tightened.
- To reduce potential fire hazard, keep the engine area free of excessive grease, grass, leaves and accumulation of dirt.
- If the engine must be running to perform a maintenance adjustment, keep hands, feet, clothing, and any parts of the body away from the engine and any moving parts. Keep everyone away.
- Do not overspeed engine by changing governor settings. Maximum engine speed is 3650 rpm. To assure safety and accuracy, have an Authorized TORO Distributor check maximum engine speed with a tachometer.
- If major repairs are ever needed or assistance is required, contact an Authorized Toro Distributor.
- To be sure of optimum performance and safety, always purchase genuine Toro replacement parts and accessories. Replacement parts and accessories made by other manufacturers could be dangerous. Altering this vehicle in any manner may affect the vehicle's operation, performance, durability or its use may result in injury or death. Such use could void the product warranty of The Toro® Company.
- This vehicle should not be modified without The Toro® Company's authorization. Direct

any inquiries to The Toro® Company, Commercial Division, Vehicle Engineering Dept., 300 West 82nd St., Bloomington, Minnesota 55420-1196. USA

- Refer to your vehicle's *Operator's Manual* for other maintenance.

Safety and Instructional Decals



Safety decals and instructions are easily visible to the operator and are located near any area of potential danger. Replace any decal that is damaged or lost.

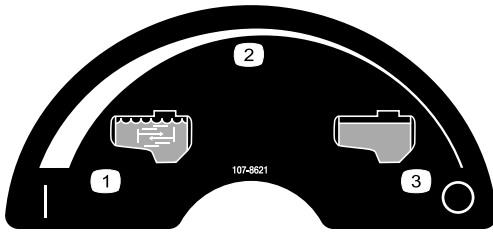

107-8621

1. Agitation on
2. Continuous variable setting
3. Agitation off

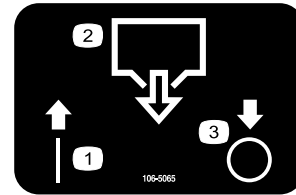

106-5065

1. On
2. Tank drain
3. Off



106-5016

1. Warning—read the *Operator's Manual*.
2. Electric shock hazard, overhead power lines—stay away from overhead power lines.
3. Crushing hazard, boom—keep bystanders a safe distance from the machine.

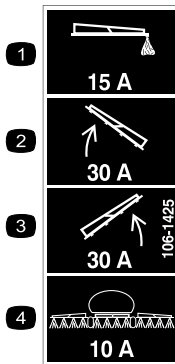

106-1425

1. 15 amp fuse, foam marker
2. 30 amp fuse, left boom actuator
3. 15 amp fuse, right boom actuator
4. 10 amp fuse, spray system actuator



93-6687

1. Do not step here.

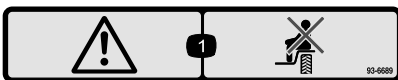

93-6689

1. Danger—do not sit on the plastic shroud.

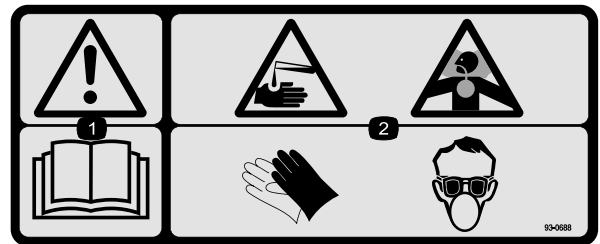

93-0688

1. Warning—read the *Operator's Manual*.
2. Caustic liquid/chemical burn and toxic gas inhalation hazards—wear hand, skin, eye, and respiratory protection.

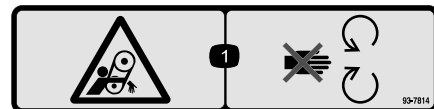

93-7814

1. Entanglement hazard, belt—stay away from moving parts.

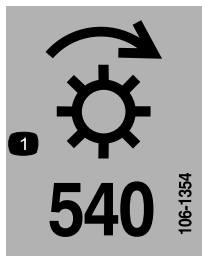

106-1354

1. 540 RPM



106-1355

1. Warning—do not enter the tank.

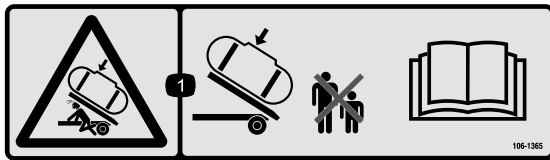

106-1365

1. Crushing hazard, sprayer tank—keep bystanders a safe distance from the sprayer tank and read the *Operator's Manual*.

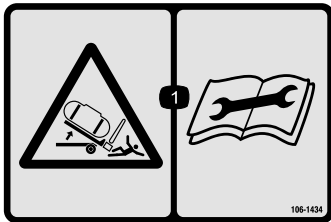

106-1434

1. Crushing hazard, sprayer tank assembly—read the *Operator's Manual* before performing maintenance.



114-9576

1. Pinch point, hand—keep hand away from hinge.



119-0651

1. Tipping hazard, loss of control—do not raise the tank when filled; do not drive the vehicle while tank is raised. Raise the tank when empty only; always lower the tank completely before driving the vehicle.

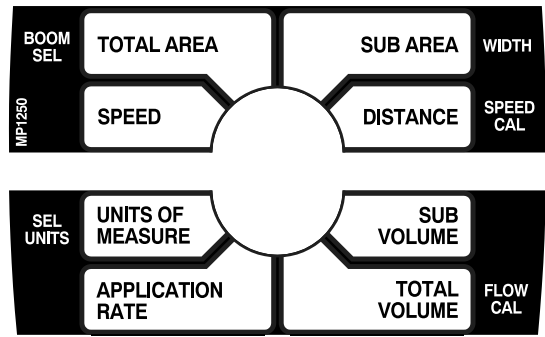

108-3307

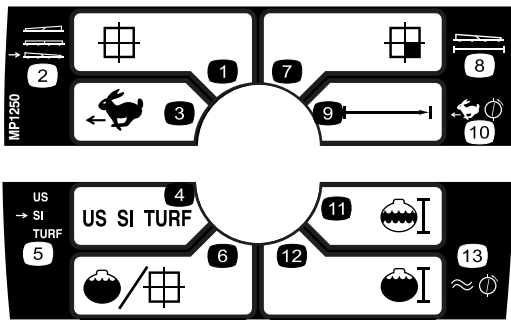

108-3309

- | | |
|---------------------|---------------------------|
| 1. Total area | 8. Width |
| 2. Boom select | 9. Distance |
| 3. Speed | 10. Speed calibration |
| 4. Units of measure | 11. Sub volume |
| 5. Select units | 12. Total volume |
| 6. Application rate | 13. Flowmeter calibration |
| 7. Sub area | |

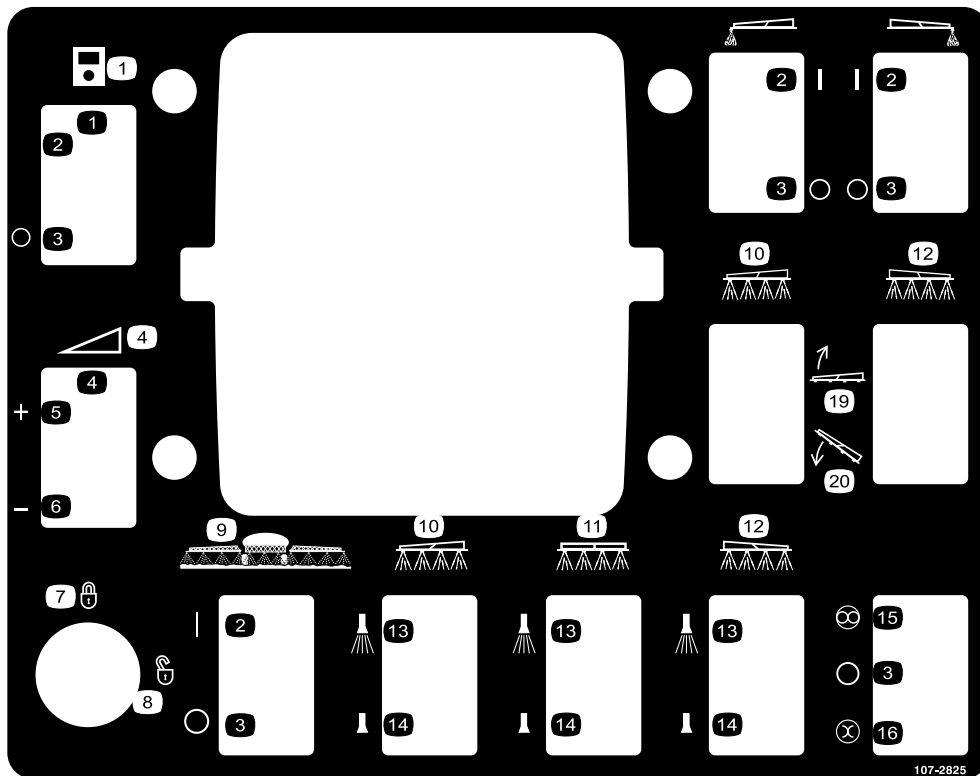

107-2825

- | | | | |
|--|----------------------|-----------------|----------------------------|
| 1. Monitor | 6. Decrease | 11. Center boom | 16. Manual |
| 2. On | 7. Locked | 12. Right boom | 17. Left boom foam marker |
| 3. Off | 8. Unlocked | 13. Spray on | 18. Right boom foam marker |
| 4. Continuous variable setting, spray pressure | 9. Master boom spray | 14. Spray off | 19. Lower the boom. |
| 5. Increase | 10. Left boom | 15. Automatic | 20. Raise the boom. |

Setup

Loose Parts

Use the chart below to verify that all parts have been shipped.

Procedure	Description	Qty.	Use
1	No parts required	–	Remove the existing bed.
2	No parts required	–	Prepare the Workman®.
3	Cover assembly Gear tooth assembly Screw (M6 x 1 inch x 12) Spring washer (M6)	1 1 1 1	Install the vehicle speed sensor.
4	No parts required	–	Install the PTO kit. (Refer to accompanying Installation Instructions)
5	Fuse block Fuse (10 amp) Thermal breaker (30 amp) Hex screw (#10-24 x 3/4 inch) Phillips screw (#10-24 x 3/4 inch) Locknut (#10-24) Wire harness Speedometer jumper harness (HD series only) Star washer Wire tires Fuse decal	1 1 2 1 1 2 1 1 1 8 1	Install the electrical harness.
6	Bolt (1/4 x 3/4 inch) Flange nut (1/4 inch) Control box mount Bolt (5/16 x 1 inch) Lock nut (5/16 inch) Adapter plate	4 4 1 4 4 1	Install the control box mount.
7	Hold-down brackets	2	Install the attachment hold-down brackets.
8	Radiator cover assembly Bolt (1/4 x 3/4 inch)	1 4	Install the radiator cover.
9	Tank and skid assembly Clevis pins Lynch pins Bolt (1/2 x 1-1/2 inches) Washers (1/2 inch) Nuts (1/2 inch)	1 2 4 2 4 2	Install the tank skid.
10	Knob J-clips Bolt (1/4 x 3/4 inch) Flange nut (1/4 inch) Spray Pro decal, US Spray Pro decal, CE	1 3 1 1 1 1	Install the control box.

Procedure	Description	Qty.	Use
11	Center boom assembly	1	Install the boom assembly.
	Bolt (3/8 x 1-1/4 inches)	10	
	Lock nut (3/8 inch)	10	
	Boom transport cradle	2	
	Bolt (1/2 x 1-1/4 inches)	4	
	Flange nut (1/2 inch)	4	
	Left boom extension	1	
	Right boom extension	1	
12	Hose clamps	3	Install boom hoses.
	R-clamp	2	
	Shoulder bolt	2	
	Washer	2	
	Nut	2	
14	Operator's Manual	1	Read the manuals and view the training material before operating the machine.
	Operator Training Material	1	
	Parts Catalog	1	
	Registration Card	1	
	Selection guide	1	
	Pre-delivery Inspection Sheet	1	

Note: Determine the left and right sides of the machine from the normal operating position.

1

Removing Existing Bed

No Parts Required

Procedure

1. Start the engine. Engage the hydraulic lift lever and lower the bed until cylinders are loose in slots. Release the lift lever and the turn off engine.
2. Remove the lynch pins from the outer ends of the cylinder rod clevis pins (Figure 3).

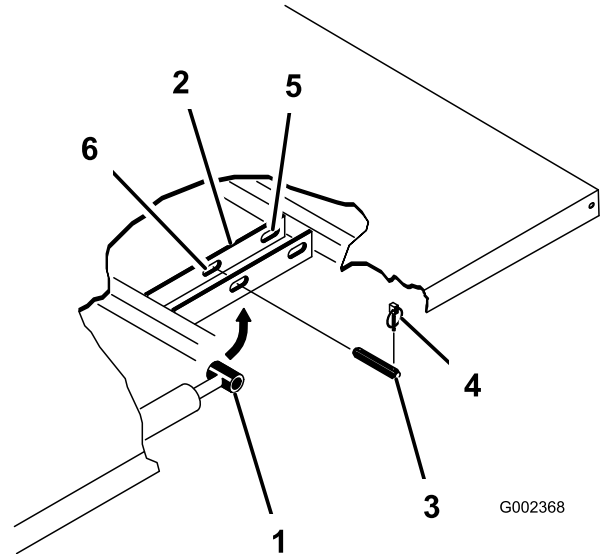

Figure 3

- | | |
|-----------------------|--------------------------|
| 1. Cylinder rod end | 4. Lynch pin |
| 2. Bed mounting plate | 5. Rear slots (Full bed) |
| 3. Clevis pin | 6. Front slots (2/3 bed) |

3. Remove the clevis pins securing the cylinder rod ends to the bed mounting plates by pushing the pins toward the inside (Figure 3).
4. Remove the lynch pins and clevis pins securing the pivot brackets to the frame channels (Figure 4)

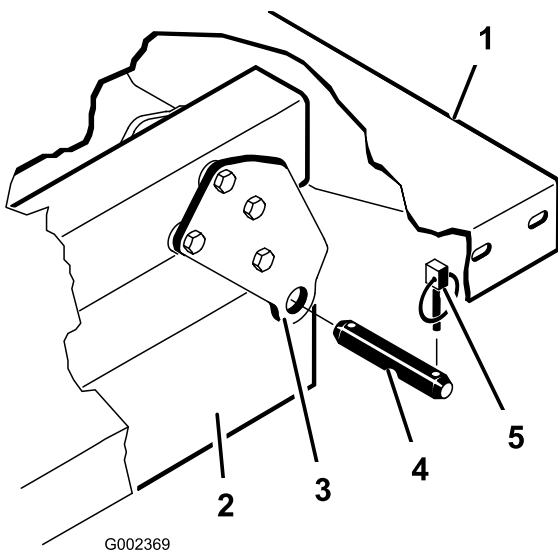

Figure 4

- | | |
|----------------------------|---------------|
| 1. Left rear corner of bed | 4. Clevis pin |
| 2. Vehicle frame channel | 5. Lynch pin |
| 3. Pivot plate | |

CAUTION

The full bed weighs approximately 210 pounds, so do not try to install or remove it by yourself. Get the help of two or three other people or use an overhead crane.

- Lift the bed off the vehicle.
- Store the cylinders in storage clips. Engage the hydraulic lift lock lever on the vehicle to prevent accidental extension of the lift cylinders.

2

Preparing the Workman®

No Parts Required

Procedure

- Park the vehicle in a safe work space with access to a lift.
- Turn the engine off and remove the key.
- Disconnect the negative battery cable from the post.

Note: This is a safety precaution since the installation will require installing an electrical harness.

3

Installing the Vehicle Speed Sensor (for Workman® 3000, 4000 series only)

Parts needed for this procedure:

1	Cover assembly
1	Gear tooth assembly
1	Screw (M6 x 1 inch x 12)
1	Spring washer (M6)

Procedure

This procedure applies to Workman HD series vehicles with a serial number of 289999999 and lower only.

Important: The speed sensor must be installed prior to the installation of the Power Take Off (PTO) kit. If a PTO kit was previously installed it must be removed at this time. See the PTO kit *Installation Instructions* for more information on removing and installing the PTO kit.

- Remove the four bolts securing the cover to the top of the transaxle housing (Figure 5). Remove the muffler bracket.

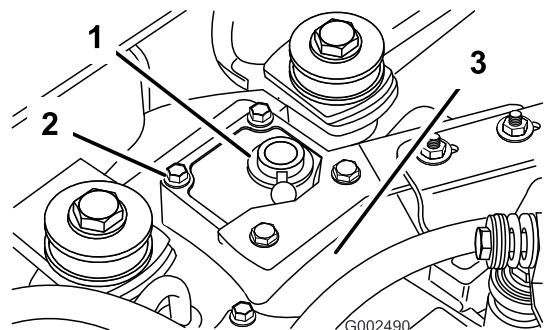
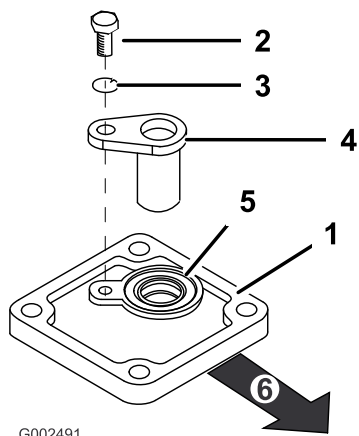

Figure 5

- | | |
|----------|----------------------|
| 1. Cover | 3. Transaxle housing |
| 2. Bolt | 4. Muffler bracket |

- Apply RTV sealant to the new cover assembly before installing it onto the transaxle unit.
- Install the new cover assembly to the transaxle using the four bolts removed in Step 1 (Figure 6). The correct orientation of the cover will have the seal facing up and positioned toward the left hand side of the vehicle.



G002491

Figure 6

- | | |
|---------------------------|---------------------|
| 1. Cover | 4. Geartooth sensor |
| 2. Screw (M6 x 1.00 x 12) | 5. Seal |
| 3. Spring washer (M6) | 6. Forward face |

4. Install the geartooth sensor using the screw (M6 x 1.00 x 12) and spring washer (M6) as shown in Figure 6.
5. Install the muffler bracket over the new cover assembly.

4

Installing the Power Take-Off (PTO) Kit (for Workman® 3000, 4000 series only)

No Parts Required

Procedure

Suspend the setup of the Workman 200 Spray System at this time to install the PTO kit. Refer to the accompanying *Installation Instructions* for more information.

Continue to the next step once completed.

5

Installing the Electrical Harness

Parts needed for this procedure:

1	Fuse block
1	Fuse (10 amp)
2	Thermal breaker (30 amp)
1	Hex screw (#10-24 x 3/4 inch)
1	Phillips screw (#10-24 x 3/4 inch)
2	Locknut (#10-24)
1	Wire harness
1	Speedometer jumper harness (HD series only)
1	Star washer
8	Wire tires
1	Fuse decal

for Workman® 3000, 4000 series

1. Remove the screws holding the front hood to the frame. Disconnect the wiring harness attached to the headlights. Remove the hood to access the electrical wiring.
2. Locate the electrical wire harness and fuse block in loose parts.
3. Remove the two screws from the existing fuse block and slide the new fuse block into the grooves of the existing block.
4. Wire the electrical harness to the fuse block by joining the wires in the harness to the corresponding wire connectors in the back of the fuse block (Figure 7).

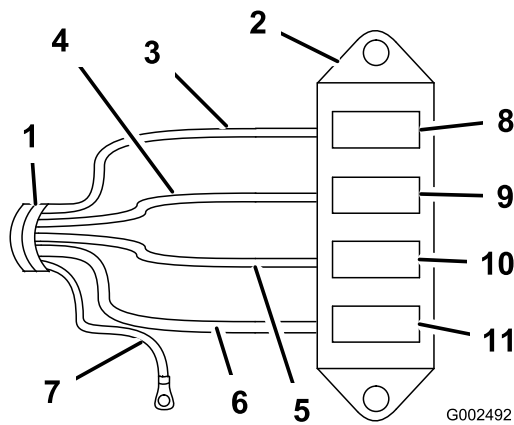

Figure 7

- | | |
|-------------------|----------------------------------|
| 1. Wire harness | 7. Black ground wire |
| 2. New fuse block | 8. Foam marker fuse slot |
| 3. Yellow wire | 9. Left boom actuator slot |
| 4. Orange wire | 10. Right boom actuator slot |
| 5. Red wire | 11. Spray system power fuse slot |
| 6. Pink wire | |

5. Connect the black ground wire to the existing 1/4 inch bolt on the interior side of the vehicle frame, using the star washer (Figure 8).

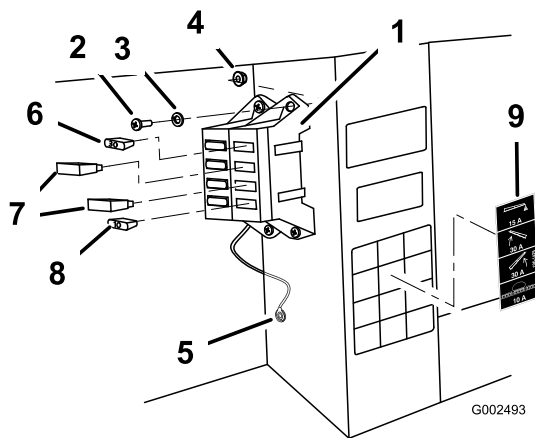

Figure 8

- | | |
|--|---|
| 1. Fuse block | 6. Fuse 15 amp, foam marker (Optional) |
| 2. Screws (#10-24 x 3/4 inch) | 7. Thermal breaker 30 amp, boom actuators |
| 3. Lock washer | 8. Fuse 10 amp, spray system power |
| 4. Lock nut (#10-24 inch) | 9. Fuse decal |
| 5. Black ground wire, star washer and bolt | |

6. Locate an open red power wire coming from the existing fuse block. Connect it to the matching red power wire coming from the new fuse block.
7. Install the fuse block and harness to the frame along side the existing fuse block, using the two screws

(#10-24 x 3/4 inch) and two locknuts (#10-24) as shown in Figure 8.

8. Remove any dirt, grease from the existing fuse block decal and make sure the surface is clean and dry. Place the decal
9. Install the fuses and thermal breakers:
- Install the two 30 amp thermal breakers to the left and right boom lift fuse slots (Figure 8).
 - Install the 10 amp fuse to the spray system power fuse slot (Figure 8).
10. Route the wiring harness through the opening in the floor, under the seat base, and rearward along with the existing wiring.
11. At the ROPS cover, rear of the seat assembly, route the wiring harness up from under the seat and above the frame. Make sure the spray system power connector is out from underneath the vehicle (Figure 9).

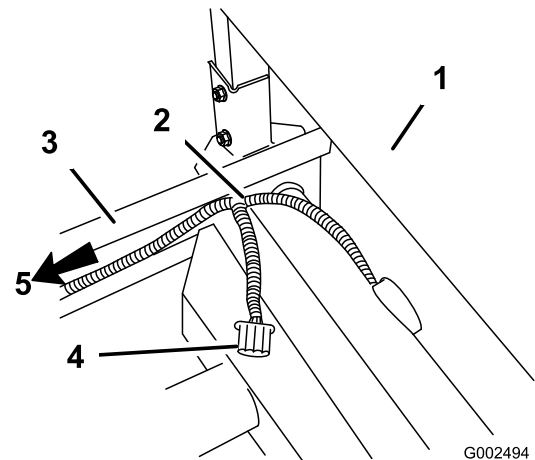

Figure 9

- | | |
|-------------------|---|
| 1. ROPS cover | 4. Spray system power connector |
| 2. Wiring harness | 5. Wire harness routed back to speed sensor |
| 3. Left frame | |

12. Route the harness along the frame and back to the speed sensor with the existing wiring (Figure 9).
13. Install the electrical connector to speed sensor.
14. Use wire ties to secure the harness to the existing wiring and position it away from any moving parts and heat sources.
15. Install the front hood and secure it with the screws removed previously.

for Workman® HD series

1. While grasping the hood in the headlight openings, lift up on the hood to release the lower mounting tabs from the frame slots (Figure 10).

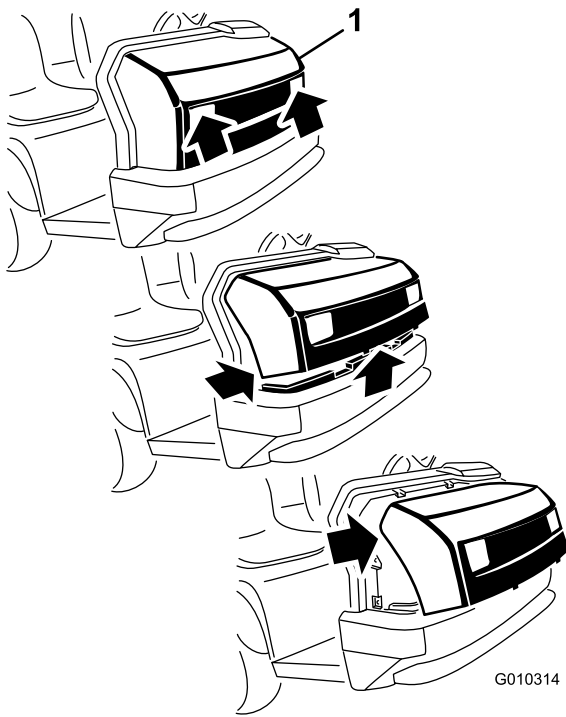

Figure 10

1. Hood

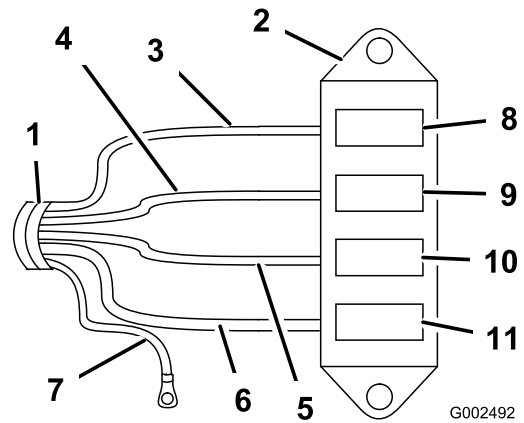

Figure 11

- | | |
|-------------------|----------------------------------|
| 1. Wire harness | 7. Black ground wire |
| 2. New fuse block | 8. Foam marker fuse slot |
| 3. Yellow wire | 9. Left boom actuator slot |
| 4. Orange wire | 10. Right boom actuator slot |
| 5. Red wire | 11. Spray system power fuse slot |
| 6. Pink wire | |

2. Pivot the bottom of the hood upward until the top mounting tabs can be pulled from the frame slots (Figure 10).
3. Pivot the top of hood forward and unplug the wire connectors from the head lights (Figure 10).
4. Remove the hood.
5. Locate the electrical wire harness and fuse block in loose parts.
6. Remove the screws securing the existing fuse blocks to the frame. Slide the new fuse block into the open grooves of the existing blocks.
7. Wire the electrical harness to the fuse block by joining the wires in the harness to the corresponding wire connectors in the back of the fuse block (Figure 11).

8. Connect the black ground wire to the existing 1/4 inch bolt on the interior side of the vehicle frame, using the star washer (Figure 12).

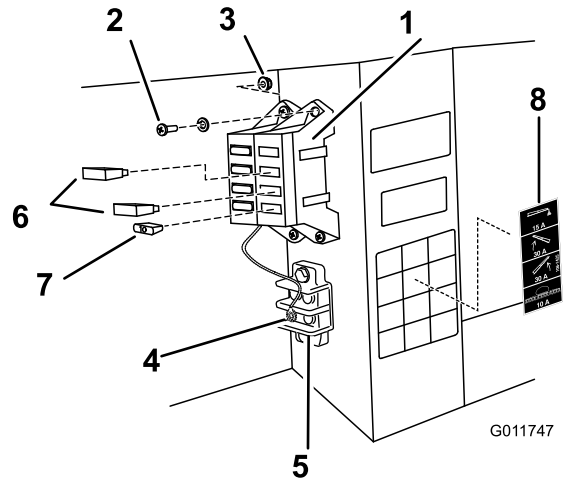

Figure 12

- | | |
|--------------------------------|---|
| 1. Fuse block | 5. Ground block |
| 2. Screws (#10-24 x 3/4 inch) | 6. Thermal breaker 30 amp, boom actuators |
| 3. Lock nut (#10-24 inch) | 7. Fuse 10 amp, spray system power |
| 4. Black ground wire | 8. Fuse decal |

9. Locate an open red power wire coming from the existing fuse block. Connect it to the matching red power wire coming from the new fuse block.
10. Install the fuse block and harness to the frame along side the existing fuse blocks, using the two screws (#10-24 x 3/4 inch) and two locknuts (#10-24) as shown in Figure 12.

11. Locate a suitable location near the fuse box to install the fuse decal. Make sure the surface is clean and dry, then place the decal
12. Install the fuses and thermal breakers:
 - A. Install the two 30 amp thermal breakers to the left and right boom lift fuse slots (Figure 12).
 - B. Install the 10 amp fuse to the spray system power fuse slot (Figure 12).
13. Route the wiring harness through the opening in the floor, under the seat base, and rearward along with the existing wiring.
14. At the ROPS cover, rear of the seat assembly, route the wiring harness up from under the seat and above the frame. Make sure the spray system power connector is out from underneath the vehicle (Figure 13).

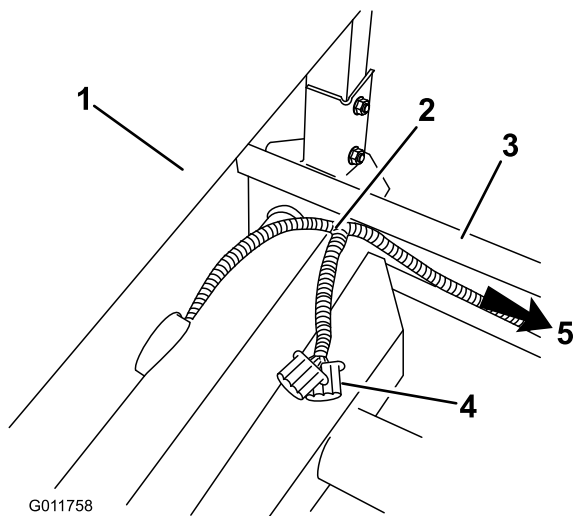

Figure 13

- | | |
|-------------------|---|
| 1. ROPS cover | 4. Spray system power connector |
| 2. Wiring harness | 5. Wire harness routed back to speed sensor |
| 3. Left frame | |

15. Route the harness along the frame and back to where the speed sensor is connected to the existing wiring (Figure 9).
16. Disconnect the speed sensor from the exiting wiring harness and connect it to the electrical connector on the spray system wiring harness.
17. Install the Y-shaped, speedometer jumper harness between the speed sensor and the existing and spray wiring harnesses. Connect the speed sensor to both the existing wire harness and the spray system wire harness (Figure 14).

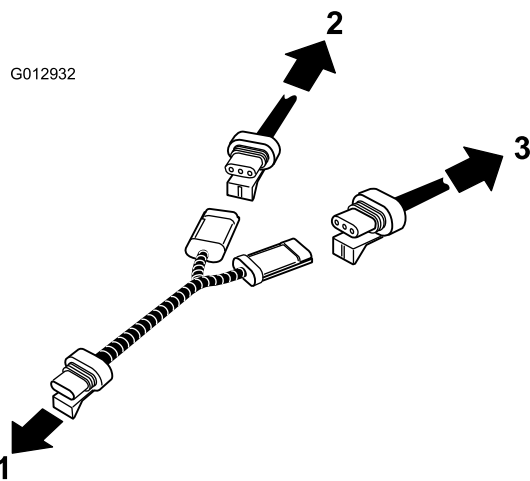

Figure 14

- | | |
|---------------------------------------|---|
| 1. Connect to speed sensor | 3. Connect to spray system wiring harness |
| 2. Connect to existing wiring harness | |

18. Use wire ties to secure the harness to the existing wiring and position it away from any moving parts and heat sources.
19. To install the hood, complete the following:
 - A. Connect the lights.
 - B. Insert the top mounting tabs into the frame slots.
 - C. Insert the lower mounting tabs into the frame slots.
 - D. Ensure that the hood is fully engaged in the top, sides and bottom grooves.

6

Installing the Control Box Mount

Parts needed for this procedure:

4	Bolt (1/4 x 3/4 inch)
4	Flange nut (1/4 inch)
1	Control box mount
4	Bolt (5/16 x 1 inch)
4	Lock nut (5/16 inch)
1	Adapter plate

For vehicles with a serial number of 240000001 or higher

On some vehicles the control mount plate is attached to the dashboard at the same point the hand throttle assembly is mounted. If the hand throttle kit is installed it must be separated from the dashboard in order to install the control mount plate. Refer to the Hand Throttle Kit *Operator's Manual* for directions in removing and installing the hand throttle assembly.

Install the control box mount to the Workman dashboard (or adapter plate) using three bolts (5/16 x 1 inch) and three lock nuts (5/16 inch) as shown in Figure 15.

Note: Some older Workman machines may use four bolts and lock nuts.

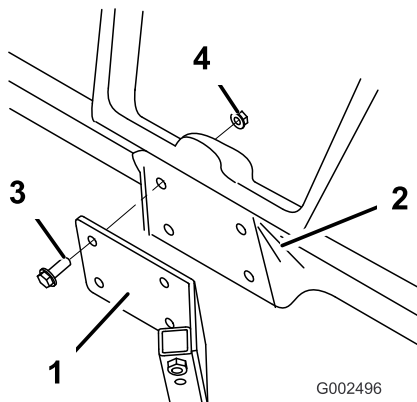

Figure 15

- | | |
|----------------------|-------------------------|
| 1. Control box mount | 3. Bolt (5/16 x 1 inch) |
| 2. Dashboard | 4. Lock nut (5/16 inch) |

For vehicles with a serial number of 239999999 or lower

Installing the Adapter Plate

If you are installing the spray system on a Workman vehicle with a serial number of 239999999 or lower, you will need to use the adapter plate, bolts, and nuts included in the loose parts.

Install the adapter plate to the Workman dashboard using four bolts (1/4 x 3/4 inch) and four flange nuts (1/4 inch) as shown in Figure 16

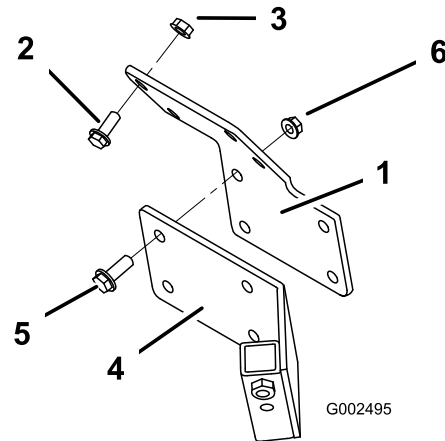

Figure 16

- | | |
|--------------------------|-------------------------|
| 1. Adapter plate | 4. Control mount |
| 2. Bolt (1/4 x 3/4 inch) | 5. Bolt (5/16 x 1 inch) |
| 3. Flange nut (1/4 inch) | 6. Lock nut (5/16 inch) |

7

Installing the Attachment Hold-down Brackets

Parts needed for this procedure:

2	Hold-down brackets
---	--------------------

Procedure

1. Locate and remove the two rear bolts and flange nuts on the lift cylinder bracket (Figure 17). Retain the fasteners for later use.

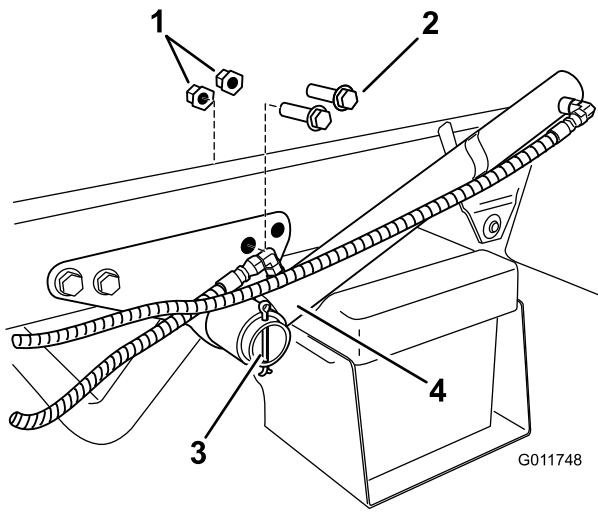

Figure 17

Left hand side shown

- 1. Lock nut
- 2. Bolts
- 3. Lift cylinder
- 4. Cotter pin

2. Remove the cotter pin securing the lift cylinder to the bracket and slide the lift cylinder outward to allow for the installation of the hold down brackets.
3. Install the hold-down brackets using the two bolts and flange nuts removed previously (Figure 18).

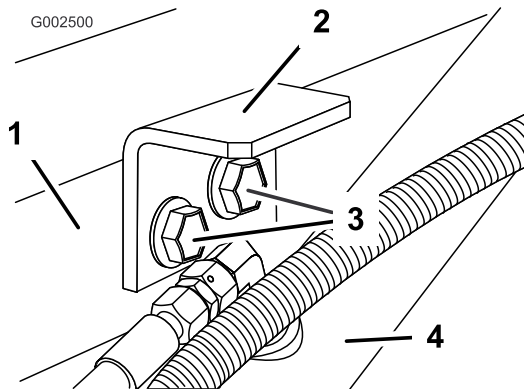

Figure 18

Left hand side shown

- 1. Lift cylinder bracket
- 2. Hold-down bracket
- 3. Bolts
- 4. Lift cylinder

4. Repeat steps to install the hold-down bracket on the opposite side.

8

Installing the Radiator Cover (for Workman® 3000, 4000 series only)

Parts needed for this procedure:

1	Radiator cover assembly
4	Bolt (1/4 x 3/4 inch)

Procedure

The radiator cover is shipped with an additional panel installed for air cooled vehicles. If you are installing the cover onto a liquid cooled vehicle, remove the extra cover.

1. Locate the spray system power connector on the wiring harness installed previously.
2. Install the radiator cover assembly over the vehicle's radiator (Figure 19).

Important: Make sure the spray system power connector is routed toward the front of the vehicle and not trapped under the radiator cover assembly.

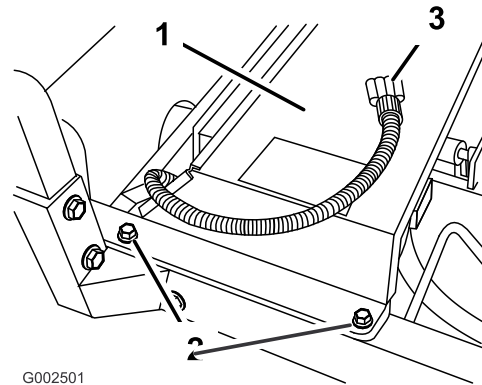

Figure 19

Left hand side shown

- 1. Radiator cover assembly
- 2. Bolt (3/8 x 1 inch)
- 3. Spray system power connector

3. Secure the cover to the frame using four bolts (3/8 x 1 inch).

9

Installing the Tank Skid

Parts needed for this procedure:

1	Tank and skid assembly
2	Clevis pins
4	Lynch pins
2	Bolt (1/2 x 1-1/2 inches)
4	Washers (1/2 inch)
2	Nuts (1/2 inch)

Procedure

▲ DANGER

The sprayer tank assembly represents a stored energy hazard. If not properly retained when installing or removing the assembly it can move or fall and injure you or other bystanders.

Use straps and an overhead lift to support the sprayer tank assembly during installation, removal or any maintenance when the retaining fasteners are being removed.

- Using a lift, raise the tank skid assembly and position over the vehicle frame with the pump and valve assemblies facing rearward.

Note: The following steps are recommended to be performed with the help of another person.

- Slowly lower the tank skid to the frame.
- Reconnect the negative battery cable and start the vehicle to energize the hydraulic pumps.
- Extend the lift cylinders to the brackets on the tank skid. Align the cylinder arms with the holes in the tank skid brackets (Figure 20).

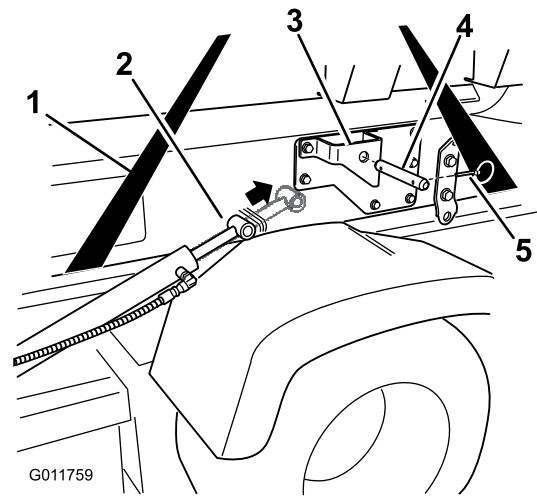

Figure 20

- Support straps
- Lift cylinders
- Tank skid brackets
- Clevis pin
- Lynch pin

- Use the clevis pin and lynch pin to secure the tank skid to the lift cylinders on both sides of the vehicle.
- Line up the pivot lug at the rear of the tank skid assembly with the opening at the end of the vehicle frame (Figure 21).

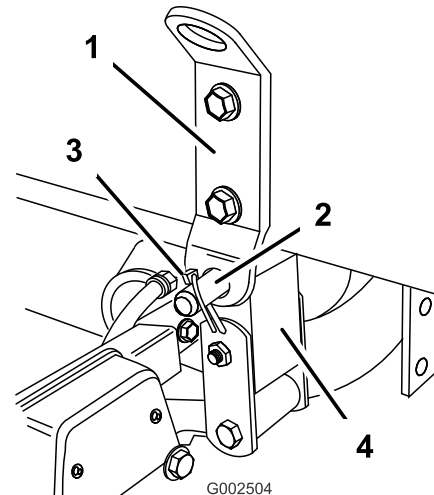

Figure 21

Left side shown

- Pivot lug
- Clevis pin (3/4 inch)
- Lynch pin
- Vehicle frame

- Install a clevis pin (3/4 inch) and two lynch pins to the pivot lug to secure the tank assembly to frame (Figure 21).
- Extend the lift cylinders to raise the tank and support its weight. Disconnect the tank assembly from its overhead support at this time.
- Use lift cylinders lower the tank to the frame.

- Check the alignment of the tank skid and the vehicle frame. If necessary, loosen the bolts securing the pivot lug to the tank skid frame slightly (Figure 21). Raise the tank assembly just enough above the vehicle frame to be aligned and lowered into proper position. Tighten the bolts on the pivot lug once the tank skid is aligned with the vehicle frame.
- Use the access panels on both sides of the tank skid to check for pinching of any hoses or wiring (Figure 22).

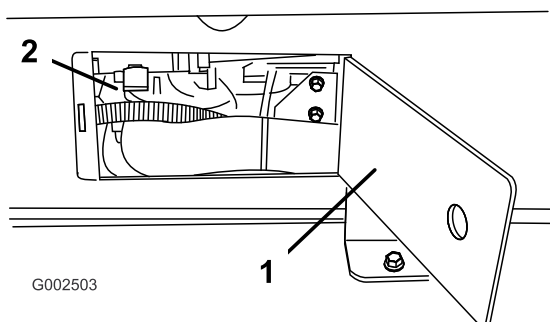

Figure 22
Right side shown

- Access panel door
- Interior of the tank skid

Important: If any hoses or wiring on the tank skid assembly are being pinched or bent, raise the assembly up, adjust its positioning, and tie items back.

- Repeat on the opposite side.
- Attach the pump drive:

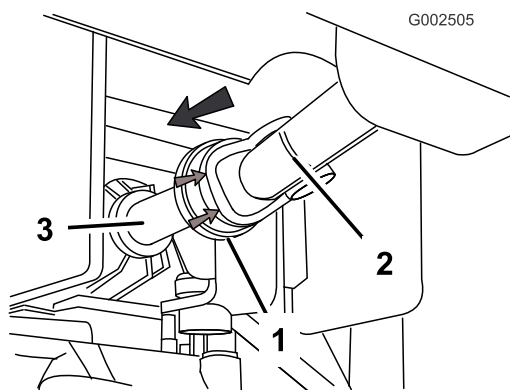

Figure 23

- Rubber cowling
- PTO drive shaft
- PTO output shaft

- Pull rearward on the rubber cowling of the front of the PTO drive shaft (Figure 23).
- Install the drive shaft onto the PTO output shaft (Figure 23).

Important: Verify the PTO shaft is secured by making sure the locking balls are seated in the groove of the output shaft.

- Line up the front mounting brackets with the hold down brackets installed previously.
- Secure the tank skid assembly to the frame with a bolt (1/2 x 1-1/2 inches), two washers (1/2 inch), and a locknut (1/2 inch) as shown in Figure 24.

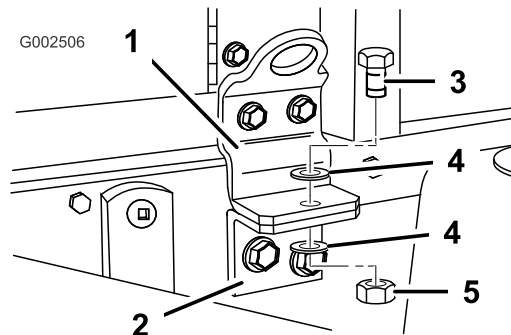

Figure 24
Left side shown

- Front mounting bracket
- Hold-down bracket
- Bolt (1/2 x 1-1/2 inches)
- Washer (1/2 inch)
- Locknut (1/2 inch)

- Repeat these steps for the front mounting bracket and hold-down bracket on the opposite side.

10

Installing the Control Box

Parts needed for this procedure:

1	Knob
3	J-clips
1	Bolt (1/4 x 3/4 inch)
1	Flange nut (1/4 inch)
1	Spray Pro decal, US
1	Spray Pro decal, CE

Procedure

The control box is mounted on the tank skid by a clevis pin, and hair pin. It is located on the left side toward the back.

- Remove the clevis pin, and hair pin securing the control box to the tank skid.

2. Install the control box, with the controls facing the driver, to the control mount using the clevis pin and hair pin removed previously.
3. Install the hand knob to stabilize the control box. Tighten by hand.
4. Install the Spray Pro Decal to the monitor (Figure 25).

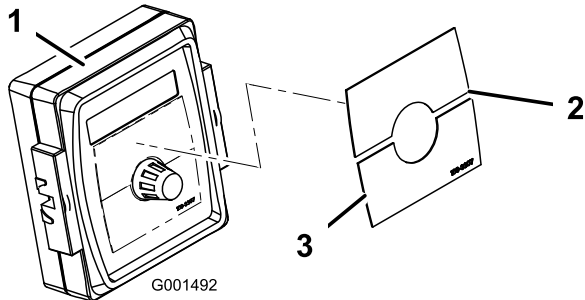

Figure 25

1. Spray pro monitor
2. Decal, Upper half
3. Decal, Lower half

Note: Be sure to orient the decal as shown in Figure 38.

5. Connect the tank skid wiring harness to the spray system power connector.
6. Install two J-clips in the center console at the points located in Figure 26 using the existing screws.

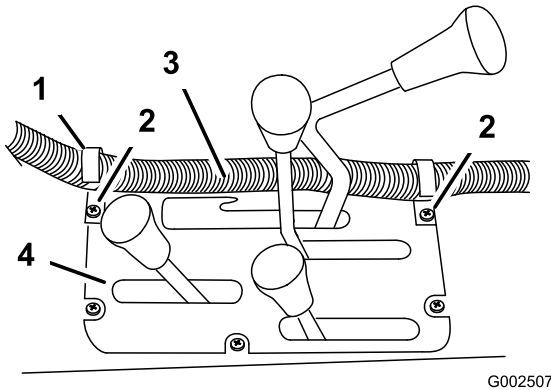

Figure 26

1. J-clip
2. Existing screws
3. Control box harness
4. Center console

7. Install a J-clip in the ROPS cover behind the operator using a bolt (1/4 x 1 inch) and a nut (1/4 inch). The hole is on the centerline, approximately 20 inches in from the operator's side edge of the ROPS cover.

Note: If a hole is not present, one must be drilled. Drill a 1/4 inch hole in the top surface of the cover on the centerline approximately 20 inches from the edge on the operator's side (Figure 27).

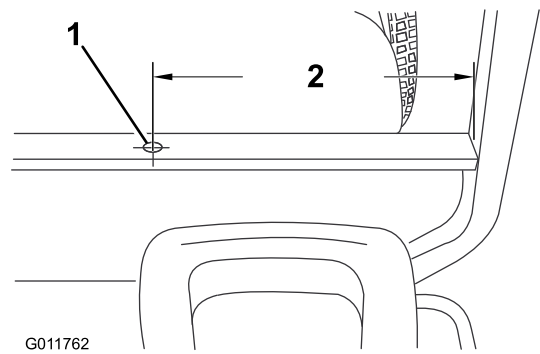

Figure 27

1. Drill hole (1/4 inch)
2. 20 inches

8. Secure the control box harness to the console and ROPS cover using the J-clips.

11

Installing the Boom Assembly

Parts needed for this procedure:

1	Center boom assembly
10	Bolt (3/8 x 1-1/4 inches)
10	Lock nut (3/8 inch)
2	Boom transport cradle
4	Bolt (1/2 x 1-1/4 inches)
4	Flange nut (1/2 inch)
1	Left boom extension
1	Right boom extension

Procedure

1. Locate and remove the center boom assembly from packaging.
2. Install the boom transport cradles to the center boom using 6 bolts (3/8 x 1-1/4 inches) and 6 lock nuts (3/8 inch). Orient them as shown in Figure 28.

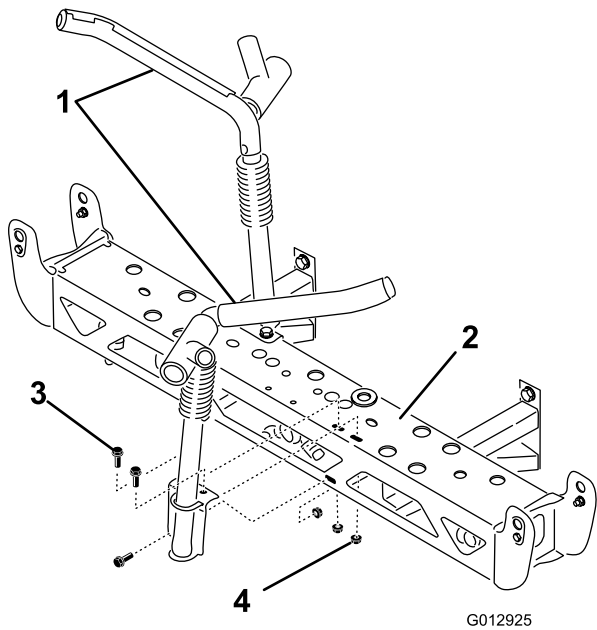

Figure 28

- | | |
|--------------------------|------------------------------|
| 1. Boom transport cradle | 3. Bolt (3/8 x 1-1/4 inches) |
| 2. Center boom | 4. Lock nut (3/8 inch) |

5. Power on the system and use the boom lift switches to extend the boom actuator rods. This is to allow the left and right boom extensions to be installed.
6. Remove the four bolts, four washers and four nuts on the hinge plate.
7. Install the extension boom to the center boom at the hinge plate using four bolts, four washers and four nuts removed in step 6 as shown in Figure 30.

Note: Ensure all spray turrets are facing to the rear.

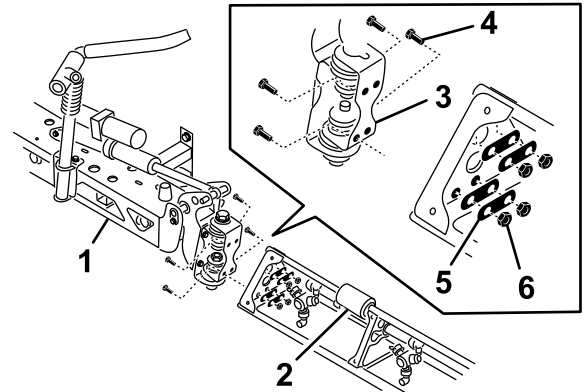

Figure 30

- | | |
|-------------------------|-----------|
| 1. Center boom assembly | 4. Bolt |
| 2. Boom extension | 5. Washer |
| 3. Hinge plate | 6. Nut |

3. Mount the center boom assembly to the spray system assembly at the boom frame mounts as shown in Figure 29 with 4 bolts (1/2 x 1-1/4 inches) and four lock nuts (1/2 inch).

Note: If necessary, the boom frame mounts can be loosened and adjusted at the center boom assembly for better hole alignment.

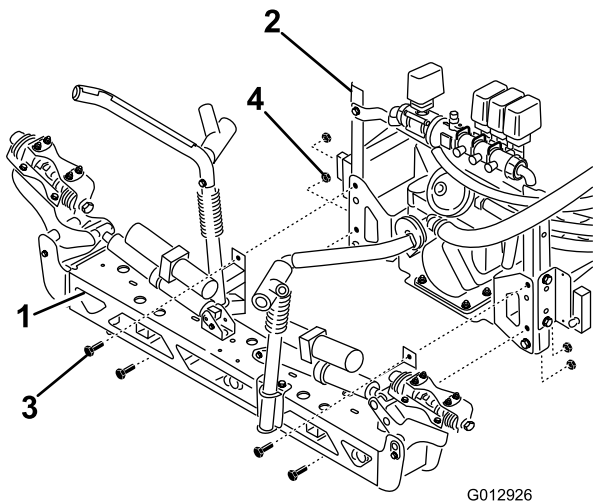

Figure 29

- | | |
|-----------------|------------------------------|
| 1. Center boom | 3. Bolt (1/2 x 1-1/4 inches) |
| 2. Boom upright | 4. Lock nut (1/2 inch) |

8. Repeat step 7 on the other side of the center boom assembly with the opposing boom extension.

Note: Ensure all spray turrets are facing to the rear.

4. Connect the boom actuators wires to the corresponding connectors on the spray system harness.

12

Installing Boom Hoses

Parts needed for this procedure:

3	Hose clamps
2	R-clamp
2	Shoulder bolt
2	Washer
2	Nut

Procedure

1. Route the boom hoses as shown in Figure 31.

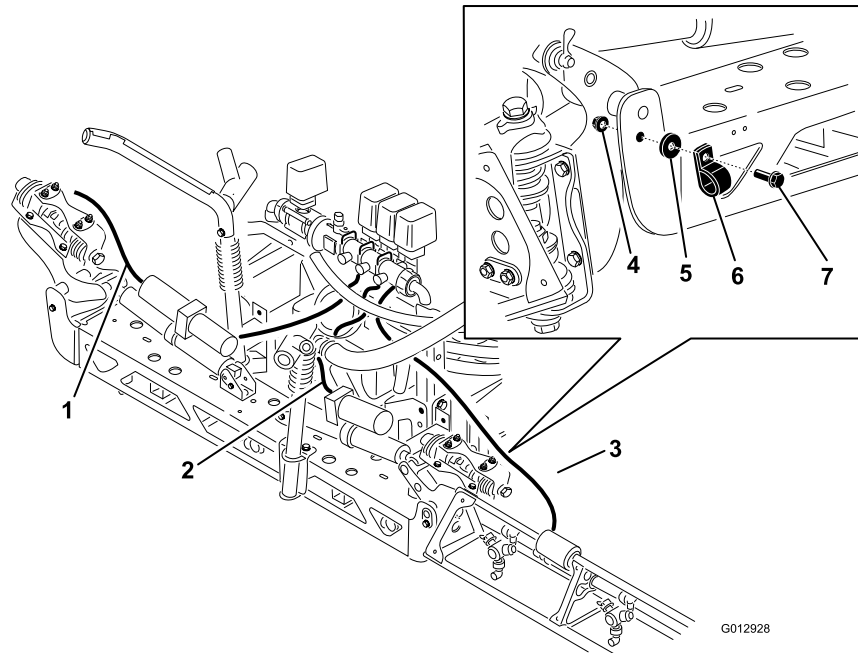

Figure 31

1. Boom hose, left extension
2. Boom hose, center
3. Boom hose, right extension
4. Nut
5. Washer
6. R-clamp
7. Shoulder bolt

2. Use the R-clamps to secure the right and left boom hoses to the front side of the center boom assemblies. Secure the hoses and R-clamps with a shoulder bolt, a washer and a nut as shown in Figure 31.

- Use liquid soap to coat the hose barb of the tee connections on both extension booms (Figure 32). Install the boom extension hose over the barb and secure it with a clamp.

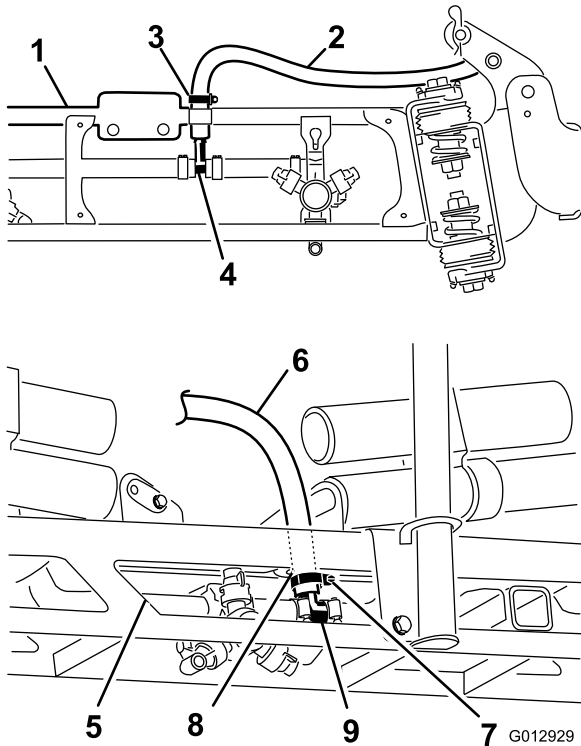

Figure 32

- | | |
|-------------------|-------------------|
| 1. Boom extension | 6. Boom hose |
| 2. Boom hose | 7. Clamp |
| 3. Clamp | 8. Grommet |
| 4. Tee connection | 9. Tee connection |
| 5. Center boom | |

- Use liquid soap to coat the hose barb of the center boom tee connection Figure 32.
- Route the center boom hose through the grommetted opening in the center boom assembly. Connect the center boom supply hose to the soaped barb and secure it with a hose clamp Figure 32.

13

Installing the Nozzles

No Parts Required

Procedure

The nozzles you use to apply your chemicals vary depending on the rate of application that you need; therefore, nozzles are not supplied with the kit. To

obtain the correct nozzles for your needs, contact your Authorized Toro Distributor and be prepared to give them the following information:

- The recommended application rate in US gallons per acre, US gallons per 1000 sq ft, or liters per hectare.
- The target speed or the vehicle in miles per hour or kilometers per hour.
- The nozzle spacing (typically 20 inches or 50 cm).

To install a nozzle, complete the following:

- Thread or insert the nozzle into the nozzle receptacle followed by a gasket.
- Slide the nozzle receptacle over the nozzle fitting on a turret.
- Turn the nozzle clockwise to lock the cams on the receptacle in place.
- Verify the fan portion of the nozzle.

See the *Installation Instructions* accompanying the nozzles for more information.

14

Completing the Setup: Learning more about your product.

Parts needed for this procedure:

1	<i>Operator's Manual</i>
1	Operator Training Material
1	<i>Parts Catalog</i>
1	Registration Card
1	Selection guide
1	Pre-delivery Inspection Sheet

Procedure

- Read the manuals.
- View the Operator training material.
- Use the nozzle selection guide to choose the correct nozzles for your specific application.
- Store the documentation in a safe place.

Product Overview

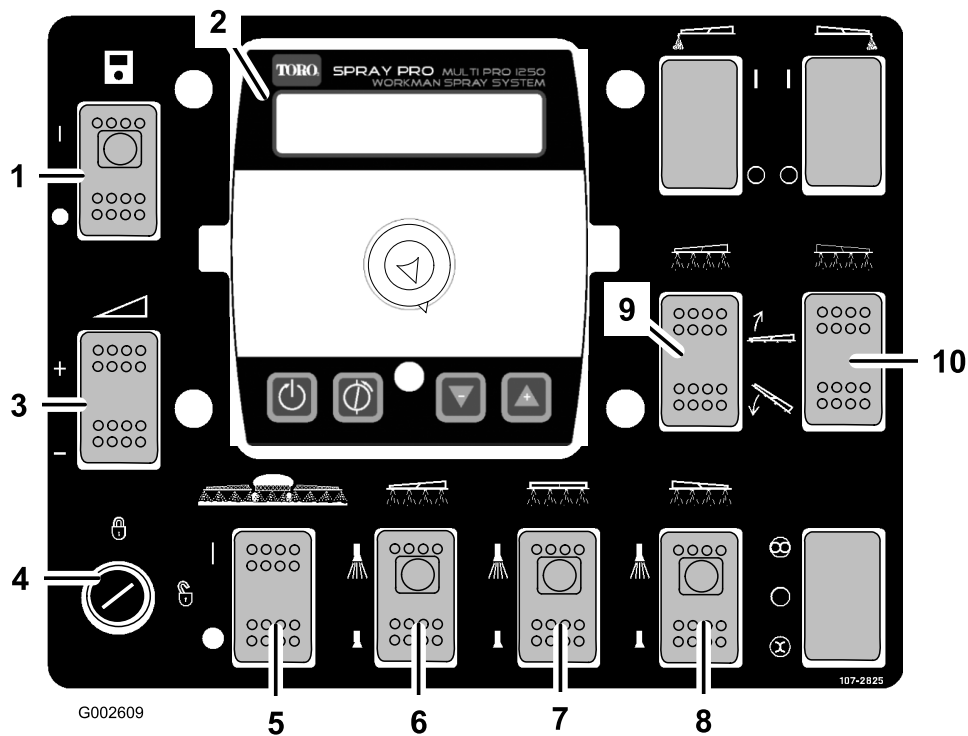

Figure 33

- | | | | |
|-------------------------------------|----------------------------|--------------------------|----------------------------|
| 1. Power switch, Spray Pro™ monitor | 4. Rate lockout key switch | 7. Center boom switch | 10. Right boom lift switch |
| 2. Spray Pro™ monitor | 5. Master boom switch | 8. Right boom switch | |
| 3. Application rate switch | 6. Left boom switch | 9. Left boom lift switch | |

Controls

Spray Pro™ Monitor Power Switch

The Spray Pro monitor power switch is the On/Off switch for the monitor. Press the switch to enable or disable the Spray Pro monitor (Figure 33). When the switch is turned on, a light on the switch illuminates.

Master Boom Switch

The master boom switch allows you to start or stop the spray operation. Press the switch to enable or disable the spray system (Figure 33). When the master switch is off, the Spray Pro screen reads “Hold.”

Boom Switches

The boom switches are located along the bottom of the control panel (Figure 33). Toggle each switch upward to turn the corresponding boom section on and downward to turn them off. When the switch is turned on, a light on the switch illuminates. These switches will only affect the spray system when the master boom switch is on.

Application Rate Switch

The application rate switch is located on the left side of the control panel (Figure 33). Press and hold the switch upward to increase the spray system application rate, or press and hold it downward to decrease application rate.

Rate Lockout Key Switch

The rate lockout key switch is located on the lower, left corner of the control panel (Figure 33). Turn the key counterclockwise to the locked position to disable the application rate switch, thereby keeping anyone from accidentally changing the application rate. Turn the key clockwise to the unlocked position to enable the application rate switch.

Boom Lift Switches

The electric boom lift switches raise and lower their respective booms (Figure 33). There is a left and right lift switch. Press and hold the switch upward to raise the respective boom, or press and hold the switch downward to lower the respective boom.

Sonic Boom and Foam Marker Switch Locations (Optional)

If you install the sonic boom and/or the foam marker kit, you will add switches to the control panel for controlling their operation. The sprayer comes with plastic plugs in these locations.

Regulating (Rate Control) Valve

This valve, located behind the tank (Figure 34), controls the amount of fluid that is routed to the booms by directing fluid flow to the booms or the bypass hose to the agitation valve.

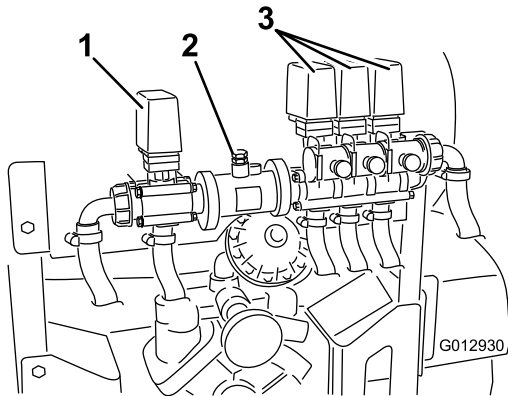

Figure 34

1. Regulating (rate control) valve
2. Flowmeter
3. Boom valves

Flowmeter

The flowmeter measures the flow rate of the fluid for use by the Spray Pro™ system (Figure 34).

Boom Valves

These valves turn the three booms on or off (Figure 34). If you do not have a boom installed or do not want a boom to be able to be turned on, you can manually operate each valve by disconnecting the wire connector in the valve, then rotate the knob on the valve clockwise to turn the valve off or counterclockwise to turn it on.

Boom Bypass Valves

The boom bypass valves redirect the fluid flow for a boom to the tank when you turn off the boom section. You can adjust these valves to ensure that the boom pressure remains constant no matter how many booms are on. Refer to Calibrating the Boom Bypass Valves, in the Operation section.

Agitation Control Valve

This valve is located on the right side of the tank (Figure 35). Turn the knob on the valve to the 9 o'clock position to turn on the tank agitation and to the 3 o'clock position to turn off the tank agitation.

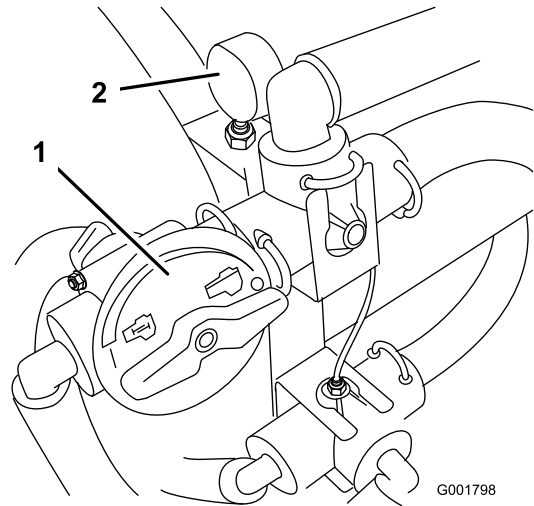

Figure 35

1. Agitation control valve
2. Pressure gauge

Note: For agitation to work, the PTO and clutch must be engaged, and the engine must be running above an idle. If you stop the sprayer and need agitation on, place the range shift lever in the Neutral position, let out the clutch, set the parking brake, and set the hand throttle (if equipped).

Pressure Gauge

The pressure gauge is located to the right of the tank (Figure 35). This gauge shows the pressure of the fluid in the system in psi and bar.

Tank Drain Handle

The tank drain handle is located on top of the tank (Figure 36). To open the tank drain, loosen the nut and pull upwards on the T-handle until the desired drain flow is achieved.

Important: Pull the handle gently. Do not pull too hard or you may damage the tank drain components.

Tighten the plastic nut lock at the base of the handle lock the tank drain in the open position. When the tank has drained, loosen the plastic nut and push the T-handle down until it stops. Tighten the plastic nut to secure the tank drain in the closed position.

Note: The plastic nut on the tank drain should be tightened when not in use to prevent leaks at the drain handle.

Important: Do not allow the hose receptacle to contact tank fluids. Do not lengthen the hose to allow contact with the tank fluids.

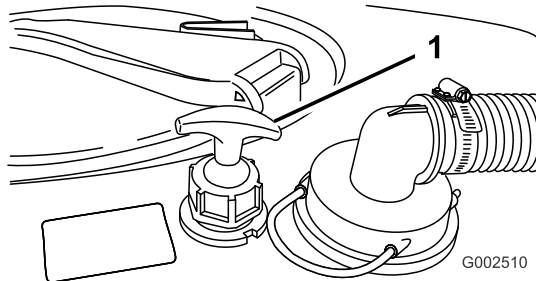

Figure 36

1. Tank drain handle

Tank Cover

The tank cover is located in the center of the top of the tank (Figure 37). To open it, turn off the engine and set the parking brake, then turn the front half of the cover to the left and swing it open. You can remove the strainer inside for cleaning. To seal the tank, replace the strainer if removed, close the cover, and rotate the front half toward the right.

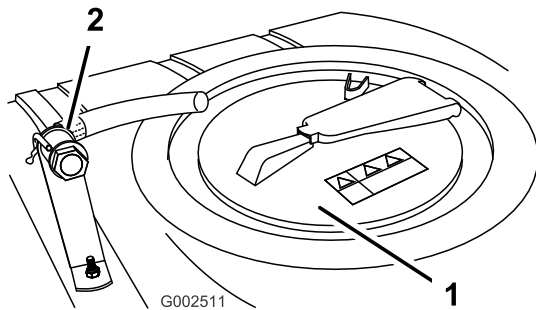

Figure 37

1. Tank cover
2. Anti-siphon fill receptacle

Anti-siphon Fill Receptacle

The anti-siphon fill receptacle, in front of the tank cover, is a hose receptacle with a threaded fitting and a 90 degree barbed fitting which you can direct toward the tank opening (Figure 37). This receptacle allows you to connect a water hose and fill the tank without contaminating the hose and water supply with the chemicals in the tank. Cut the hose to a length that allows the minimum distance between the water and the end of the hose without the hose touching the water and complying with local regulations, typically 4 to 8 inches (10 to 20 cm).

Spray Pro™ Monitor

The Spray Pro monitor displays and monitors various system performance data such as vehicle speed and application rates. It does not control the application rate.

The monitor has an LCD screen that displays the data you select, a selection dial, and 4 buttons for calibrating the monitor (Figure 38).

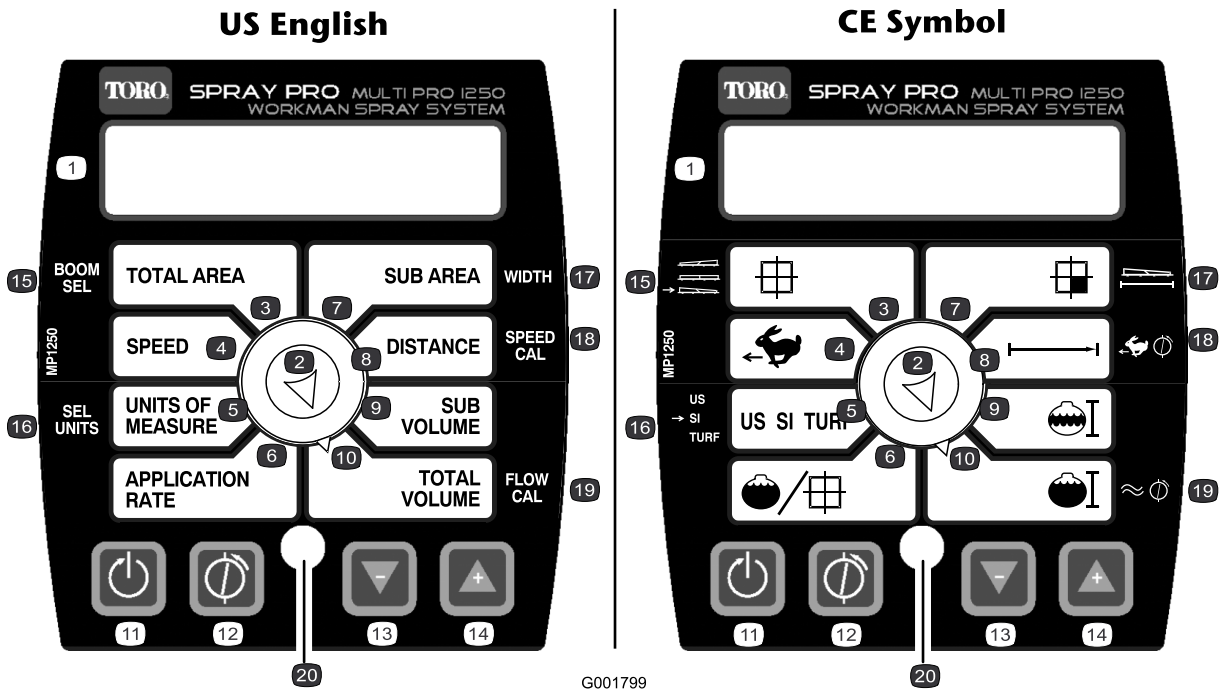

Figure 38

- | | | | |
|---------------------|---------------------|-----------------------------------|---------------------------|
| 1. LCD screen | 6. Application rate | 11. Reset, calibration button | 16. Select units |
| 2. Selection dial | 7. Distance | 12. Calibrate, calibration button | 17. Width |
| 3. Total area | 8. Sub Area | 13. Decrease, calibration button | 18. Speed calibration |
| 4. Speed | 9. Sub volume | 14. Increase, calibration button | 19. Flowmeter calibration |
| 5. Units of measure | 10. Total volume | 15. Boom selection | 20. LED |

Monitor Display Selection Dial

Use the dial to set the LCD screen display to the following:

- Total area**
 Displays the total acres (US), hectares (SI), or sq feet (TURF) that you have covered since you last pressed the Reset calibration button for this setting.
- Speed**
 Displays the ground speed in miles per hour (if the Units of Measure is set to US or TURF) or kilometers per hour (if the Units of Measure is set to SI).
- Units of Measure**
 Displays the current measurement unit selection as follows:
 - US (United States measuring system)
 - SI (metric system)
 - TURF (as US but the volumes are in US gallons per 1000 sq ft instead of US gallons per acre)

- Application Rate**
 Displays the application rate in US gallons per acre (US), liters pre hectare (SI), or US gallons per 1000 sq ft (TURF).
- Sub Area**
 Displays the total acres (US), hectares (SI), or sq feet (TURF) that you have covered since you last pressed the Reset calibration button for this setting, without affecting the Total Area display. If you press the Reset calibration button, the Sub Volume resets.
- Distance**
 Displays the distance you have traveled in feet (US and TURF) or meters (SI) since you last pressed the Reset calibration button for this setting.
- Sub Volume**
 Displays the total volume in US gallons (US and TURF) or liters (SI) that you have applied since you last pressed the Reset calibration button for this

setting, without affecting the Total Volume display. If you press the Reset calibration button, the Sub Area resets.

- **Total Volume**

Displays the total volume in US gallons (US and TURF) or liters (SI) that you have applied since you last pressed the Reset calibration button for this setting.

Calibration Buttons

The monitor has the following buttons:

- **Reset**

Resets the Total Volume, Sub Volume, Distance, Total Area, and Sub Area display settings to 0.

- **Calibrate**

Used to enter and exit the calibration mode.

- **Decrease**

Reduces values displayed on the screen during calibration.

- **Increase**

Increases values displayed on the screen during calibration.

Calibration Settings

- Boom Width
- Units of Measure
- Speed/Distance
- Flowmeter

Specifications

Note: Specifications and design are subject to change without notice.

Spray system base weight	676 lb (307 kg)
Tank capacity	200 US gallons (757 L)
Overall vehicle length with the standard spray system	166 inches (422 cm)
Overall vehicle height with standard spray system to the top of the tank	58 inches (147 cm)
Overall vehicle height with standard spray system and the booms stored in the X pattern	92 inches (234 cm)
Overall vehicle width with the standard spray system and the booms stored in the X pattern	69 inches (175 cm)

Optional Equipment

The Toro® Company has optional equipment and accessories that you can purchase separately and install on your Workman. Contact your Authorized Service Dealer for a complete list of optional equipment that is currently available for your sprayer.

Operation

Note: Determine the left and right sides of the machine from the normal operating position.

Think Safety First

Please carefully read all of the safety instructions and decals in the safety section. Knowing this information could help you or bystanders avoid injury.

Filling the Fresh Water Tank

Always fill the fresh water tank with clean water before handling or mixing any chemicals.

The sprayer is equipped with a fresh water tank (Figure 39). It supplies a source of fresh water for you to wash chemicals off of your skin, eyes, or other surfaces in the case of accidental exposure.

To open the fresh water tank spigot, turn the lever on the spigot toward the front of the sprayer.

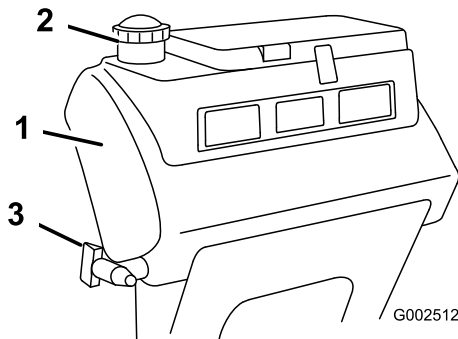

Figure 39

- | | |
|---------------------|-----------|
| 1. Fresh water tank | 3. Spigot |
| 2. Filler cap | |

Adjusting the Booms to Level

The following procedure can be used to adjust the hardstops on the center boom to keep the left and right booms at level.

1. At the operator's position, turn the ignition key to On to energize the system.
2. Move the booms into position so that they are level with the ground.
3. Remove the key and exit the operator's position.

4. At the hinge, adjust the position of the bumpers so the boom can not move past level with the ground. Take care to make sure the bumper is level.
5. Tighten the bolt and nut to lock the bumpers into the adjusted position. Torque the fasteners to 135-165 ft-lbs (183-223 N-m).

Note: The bumper may experience some compression over time. If the booms drop below level, use this procedure to readjust the bumper position needed.

Operating the Sprayer

To operate the Workman 200 Spray System first fill the spray tank, then apply the solution to the work area, and finally clean the tank. It is important that you complete all three of these steps in succession to avoid damaging the sprayer. For example, do not mix and add chemicals in the spray tank at night and then spray in the morning. This would lead to separation of the chemicals and possible damage to the sprayer components.

⚠ CAUTION

Chemicals are hazardous and can cause personal injury.

- **Read the directions on the chemical labels before handling the chemicals and follow all manufacturer recommendations and precautions.**
- **Keep chemicals away from your skin. Should contact occur, wash the affected area thoroughly with soap and clean water.**
- **Wear goggles and any other protective equipment recommended by the chemical manufacturer.**

The Workman 200 Spray System has been specifically designed to have high durability in order to give it the long sprayer life you need. Different materials have been chosen for specific reasons at different locations on your sprayer to meet this goal. Unfortunately there is no single material which is perfect for all foreseeable applications.

Some chemicals are more aggressive than others and each chemical interacts differently with various materials. Some consistencies (e.g. wettable powders, charcoal) are more abrasive and lead to higher than normal wear rates. If a chemical is available in a formulation that would provide increased life to the sprayer, use this alternative formulation.

As always, remember to clean your sprayer thoroughly after all applications. This will do the most to ensure your sprayer has a long and trouble free life.

Filling the Spray Tank

Important: Ensure that the chemicals you will be using are compatible for use with Viton (see the manufacturer's label; it should indicate if it is not compatible). Using a chemical that is not compatible with Viton will degrade the O-rings in the sprayer, causing leaks.

1. Stop the sprayer on a level surface, move the range selector to the Neutral position, stop the engine, and set the parking brake.
2. Determine the amount of water needed to mix the amount of chemical you need as prescribed by the chemical manufacturer.
3. Open the tank cover on the spray tank.

The tank cover is located in the center of the top of the tank (Figure 40). To open it, turn the front half of the cover counterclockwise and swing it open. You can remove the strainer inside for cleaning. To seal the tank, close the cover and rotate the front half clockwise.

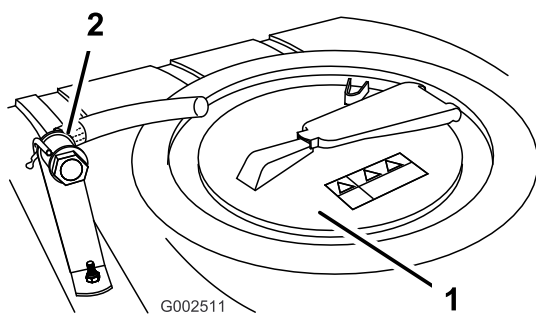

Figure 40

1. Tank cover
2. Anti-siphon fill receptacle

4. Add 3/4 of the required water to the spray tank using the anti-siphon fill receptacle.

Important: Always use fresh clean water in the spray tank. Do not pour concentrate into an empty tank.

5. Start the engine, engage the PTO, and set the hand throttle if equipped.
6. Turn the agitation control valve to the 9 o'clock position to start agitation in the tank.
7. Add the proper amount of chemical concentrate to the tank, as directed by the chemical manufacturer.

Important: If you are using a wettable powder, mix the powder with a small amount of water to form a slurry before adding it to the tank

8. Add the remaining water to the tank.

Note: Better agitation can be achieved by decreasing the application rate setting.

Operating the Booms

The boom lift switches on the sprayer control panel allows you to move the booms between transport position and spray position without leaving the Operator's seat. It is recommended to change boom positions while the machine is stationary.

To change the boom position:

1. Stop the machine on level ground.
2. Use the boom lift switches to lower booms. Wait until the booms reach the full, extended spray position.
3. When the booms need to be retracted, stop the sprayer on level ground.
4. Use the boom lift switches to raise the booms. Raise the booms until have moved completely into boom transport cradle forming the "X" transport position and the boom cylinders are fully retracted.

Important: To prevent damage to the boom actuator cylinder, make sure the actuators are fully retracted before transport.

Important: Release the actuator switch once the booms have reached the desired position. Running the actuators against the stops will cause the motors to overheat, tripping the breakers and risk damaging the actuators.

The Boom Transport Cradle

The sprayer is equipped with a boom transport cradle that has a unique safety feature. In the event of accidental boom contact with a low overhead object while in the transport position, the boom(s) can be pushed out of the transport cradles. If this occurs, the booms will come to rest in a near horizontal position to the rear of the vehicle. While the booms will not be damaged due to this movement, they should be immediately put back into the transport cradle.

Important: The booms can be damaged by transporting them in any position other than the "X" transport position using the boom transport cradle.

To put the booms back into the transport cradle, lower the boom(s) to the spray position, and then raise the boom(s) back into the transport position. Make

sure the boom cylinders are fully retracted to prevent actuator rod damage.

Spraying

Important: In order to ensure that your solution remains well mixed, use the agitation feature whenever you have solution in the tank. For agitation to work, the PTO must be engaged and the engine must be running above an idle. If you stop the vehicle and need agitation on, place the shift lever in the Neutral position, set the parking brake, Engage the PTO, engage the clutch, and set the hand throttle, if equipped.

Note: This procedure assumes that the PTO is engaged from the Filling the Spray Tank procedure.

1. Lower the booms into position.
2. Set the master boom switch to the Off position. The Spray Pro monitor will display “HOLD”.
3. Set the individual boom switches, as needed, to the On positions.
4. Drive to the location where you will be spraying.
5. Turn the Spray Pro selection dial to the Application Rate position and use the application rate switch to achieve the desired rate. To do this:
 - A. Ensure the pump is On.
 - B. Select the desired gear range and begin driving.
 - C. Verify the monitor displays the correct application rate. If needed, manipulate the application rate switch until the monitor displays the desired application rate.
 - D. Return to the location where spraying is to begin.
6. Set the master boom switch to the On position to begin spraying.

Note: When the tank is nearly empty, the agitation may cause foaming in the tank. In this case, turn the agitation control valve to the 3 o'clock position to turn it off. Alternatively, you can use an anti-foaming agent in the tank.

7. When finished spraying, set the master boom switch to the Off position to turn off all booms, then disengage the PTO lever.

Spraying Tips

- Do not overlap areas that you have previously sprayed.
- Watch for plugged nozzles. Replace all worn or damaged nozzles.

- Use the master boom switch to stop the spray flow before stopping the sprayer. Once stopped, use the neutral engine speed lock to hold the engine speed up to keep the agitation running.
- You will obtain better results if the sprayer is moving when you turn the booms on.
- Watch for changes in the application rate that may indicate that your speed has changed beyond the range of the nozzles or there is a problem with the spray system.

Cleaning the Sprayer

Important: You must always empty and clean the sprayer immediately after each use. Failure to do so may cause the chemicals to dry or thicken in the lines, clogging the pump and other components.

1. Stop the sprayer, set the parking brake, place the range selector in the Neutral position, and turn off the engine.
2. Use the tank drain handle to drain any unused material from the tank and dispose of it according to local codes and the material manufacturer's instructions.

The tank drain handle is located on top of the tank (Figure 41).

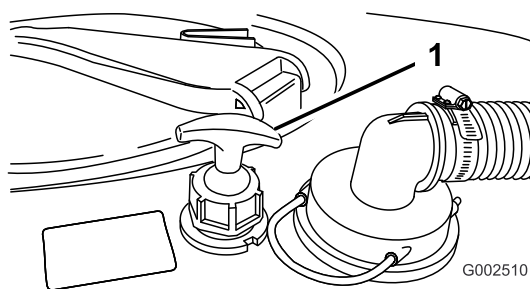

Figure 41

1. Tank drain handle

Using the Tank Drain Handle

- A. Loosen the plastic nut at the base of the handle.
- B. Pull up on the T-handle until the desired drain flow is achieved.

Important: Pull the handle gently. Do not pull too hard or you may damage the tank drain components.

- C. Tighten the plastic nut lock at the base of the handle lock the tank drain in the open position.
- D. When the tank has drained, loosen the plastic nut and push the T-handle down until it stops.
- E. Tighten the plastic nut to secure the tank drain in the closed position.

Note: The plastic nut on the tank drain should be tightened when not in use to prevent leaks at the drain handle.

3. Fill the tank with at least 50 US gallons (190 L) of clean fresh water and close the cover.

Note: You can use a cleaning/neutralizing agent in the water as needed. On the final rinse, use only clean, clear water.

4. Start the engine.
5. With the shift lever in the Neutral position, engage the PTO, and set the hand throttle.
6. Ensure that the agitation control valve is in the On position.
7. Set the master boom switch and boom control switches to the On positions to begin spraying.
8. Allow all of the water in the tank to spray out through the nozzles.
9. Check the nozzles to ensure that they are all spraying correctly.
10. Set the master boom switch to the Off position, disengage the PTO, and stop the engine.
11. Repeat steps 3 through 10 at least 2 more times to ensure that the spray system is fully cleaned.
12. Clean the strainer; refer to Cleaning the Suction Strainer in Cleaning (page 46).

Important: If you used wettable powder chemicals, clean the strainer after each tank.

13. Using a garden hose, spray off the outside of the sprayer with clean water.
14. Remove the nozzles and clean them by hand. Replace damaged or worn nozzles.

Calibrating the Spray Pro Monitor

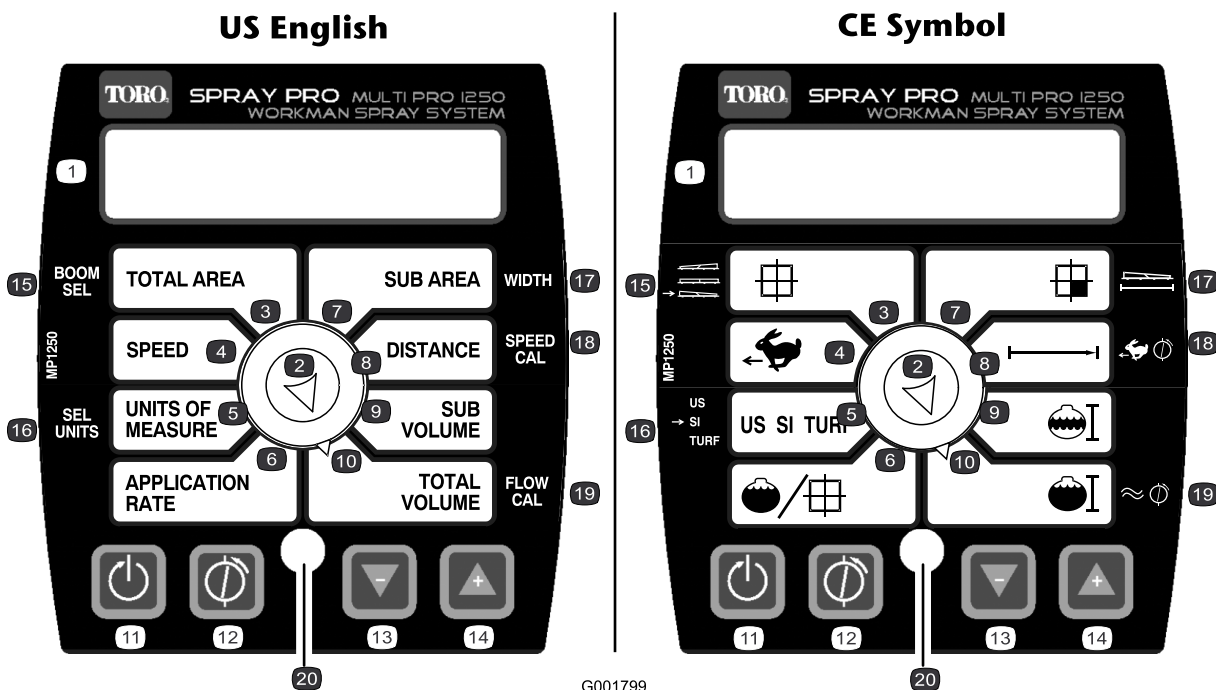

G001799

Figure 42

- | | | | |
|---------------------|---------------------|-----------------------------------|---------------------------|
| 1. LCD screen | 6. Application rate | 11. Reset, calibration button | 16. Select units |
| 2. Selection dial | 7. Sub Area | 12. Calibrate, calibration button | 17. Width |
| 3. Total area | 8. Distance | 13. Decrease, calibration button | 18. Speed calibration |
| 4. Speed | 9. Sub volume | 14. Increase, calibration button | 19. Flowmeter calibration |
| 5. Units of measure | 10. Total volume | 15. Boom selection | 20. LED |

The Spray Pro monitor has a calibration mode that allows you to change various settings to customize the display and calibrate the monitor to your needs. You can calibrate or change the following settings:

- Boom Width
- Units of Measure
- Speed
- Flowmeter

Setting the Boom Width

The default settings for the boom widths are 80 inches (2.03 m) for the right and left booms and 60 (1.524 m) for the center boom. This is based on 4 nozzles on the right and left booms and 3 on the center boom all spaced 20 inches (50.8 cm) apart. If you change the spacing of the nozzles, you should change the boom width to reflect your changes as follows:

1. Stop the sprayer and set the parking brake.
2. Set the master boom switch to the Off position. The monitor displays “HOLD”.

3. Press and hold the Calibrate button until the monitor displays “CAL HOLD” and the red light on the monitor illuminates.
4. Turn the selection dial to the Boom Select (or Total Area) position.
5. Use the Increase or Decrease calibration buttons to select the boom for which you wish to change the width, where 1 is the left boom, 2 is the center boom, and 3 is the right boom.
6. Turn the selection dial to the Width (or Sub Area) position.
7. Use the Increase or Decrease calibration buttons to change the boom width as needed.
8. Repeat steps 4 through 7 for the other booms as needed.
9. Press the Calibrate button until the red light turns off. You can also exit the calibration mode by driving the sprayer.

Setting the Units of Measure

The default setting for the units of measure is US. You can also change the units to SI (metric) or TURF.

1. Stop the sprayer and set the parking brake.
2. Set the master boom switch to the Off position. The monitor displays “HOLD”.
3. Press and hold the Calibrate button until the monitor displays “CAL HOLD” and the red light on the monitor illuminates.
4. Turn the selection dial to the Select Units (or Units of Measure) position.
5. Use the Increase or Decrease calibration buttons to select desired units of measure.
6. Press the Calibrate button until the red light turns off. You can also exit calibration mode by driving the sprayer.

Calibrating the Flowmeter

Note: Perform this calibration procedure each time nozzles are changed to ensure the greatest accuracy.

The Spray Pro monitor comes approximately calibrated for the flowmeter. Complete the following procedure to fine tune the flowmeter calibration:

1. Set the parking brake.
2. Fill the sprayer tank with a known quantity of water, at least 100 US gallons (380 L).

Note: Do not rely on the marks on the side of the tank for measuring the water for this procedure. They are approximate measurements, but not accurate enough for this calibration.

3. Set the pump switch to the On position to start the pump.
4. Set all three boom switches and the master boom switch to the On position. Run the booms only until the air is purged from the line, then turn them off using the master boom switch.
5. Turn the selection dial to the Total Volume position.
6. Press and hold the Reset calibration button until the display reads “0”.
7. Set the master boom switch to the On position and run the booms until all the water is out of the tank, then stop them using the master boom switch.
8. Compare the volume displayed on the monitor to the volume of water you put into the tank.
 - If the volumes are the same, you do not need to calibrate the monitor any further.
 - If the values are different, continue with the rest of this procedure.
9. With the selection dial set to the Total Volume position, press and hold the Calibrate button until the monitor displays “CAL HOLD” and the red light on the monitor illuminates.

The display will alternate between the total volume reading (“HOLD” shown) and the flow calibration value (“CAL HOLD” shown).

10. When the total volume value is displayed, use the Increase or Decrease calibration buttons to change it to the amount of water you put in the tank.
11. When the display begins alternating again, the flow calibration value will have changed; write this number down and save it. This is the calibration value for your sprayer.
12. Press the Calibrate button until the red light turns off. You can also exit calibration mode by driving the sprayer.

Calibrating the Speed Sensor

The Spray Pro comes approximately calibrated for the speed sensor. Complete the following procedure to fine tune the speed sensor calibration:

1. Check and fill all tires; refer to Checking Tire Pressure in the Drive System Maintenance section.
2. Fill the fresh water tank.
3. Fill the sprayer tank half-full of water.
4. Select a straight, flat track of ground that is similar to your turf conditions.

Note: Using a road or other paved surface could cause an inaccurate reading when you later drive the sprayer on turf.

5. Measure 500 feet (150 m), marking both the start and end points.
6. Position the sprayer at the starting point.
7. Set the pump and the master boom switches to the Off position. The monitor should display “HOLD”.
8. Turn the selection dial to the Distance position.
9. Press and hold the Reset calibration button until the display reads “0”.
10. Press the master boom switch to start the distance tracking with the monitor. Drive the machine from the start point you marked to the 500 feet (150 m) end point.
11. Stop at the end point, set the master boom switch to the Off position to stop the monitor.
12. Look at the distance displayed on the monitor.
 - If it reads “500 feet (150 m)”, you do not need to calibrate the monitor any further.
 - If it does not read “500 feet (150 m)”, continue with the rest of this procedure.
13. Set the parking brake.

14. With the selection dial set to the Distance position, press and hold the Calibrate button until the monitor displays “CAL HOLD” and the red light on the monitor illuminates.
The display will alternate between the distance value (“HOLD” shown) and the speed calibration value (“CAL HOLD” shown).
15. When the distance value is displayed, use the Increase or Decrease calibration buttons to change it to 500 feet (150 m).
16. When the display begins alternating again, the speed calibration value will have changed; write this number down and save it. This is the calibration value for your sprayer.
17. Press the Calibrate button until the red light turns off. You can also exit calibration mode by driving the sprayer.

Resetting an OFL Condition

If the monitor reads “OFL”, it indicates that you have exceeded the monitor screen dimensions. Press and hold the Reset calibration button to set the display to 0.

Calibrating the Boom Bypass Valves

Before using the sprayer for the first time or if the nozzles are changed, adjust the boom bypass valves so that the pressure and application rate remains the same for all booms when you turn one or more booms off.

Note: The boom bypass valves must be calibrated each time the nozzles are changed.

Select an open flat area to perform this procedure.

1. Fill the spray tank with clean water.
2. Put the extension booms down, if installed.
3. Set the parking brake and start the engine .
4. Set the dial on the Spray Pro monitor to Application Rate.
5. Place the range selector in the Neutral position.
6. Press the accelerator to the floor and set the neutral engine speed lock switch to the On position.
7. Set the pump switch to the On position to start the pump.
8. Set all three boom switches and the master boom switch to the On position.
9. Use the application rate switch to adjust the pressure as read on the pressure gauge until it is in the range

for the nozzles you installed on the booms (typically 40 psi).

10. Record the reading on the pressure gauge.
11. Turn off one of the booms using the appropriate boom switch.
12. Adjust the boom bypass valve (Figure 43) on the boom control valve for the boom you turned off until the pressure reading on the gauge is the same as it was in step 9.

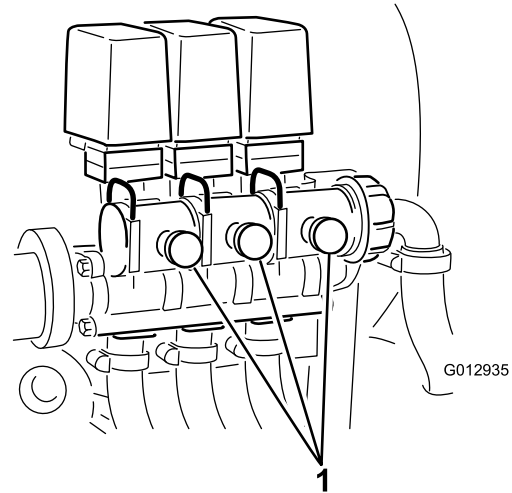

Figure 43

1. Boom bypass valves

13. Turn the boom on and off to verify the pressure does not change.
14. Repeat steps 11 through 13 for the other booms.
15. Drive the sprayer at the desired speed while spraying and turn each boom off individually. The pressure on the gauge should not change.

Pump

The pump is located near the rear of the vehicle (Figure 44).

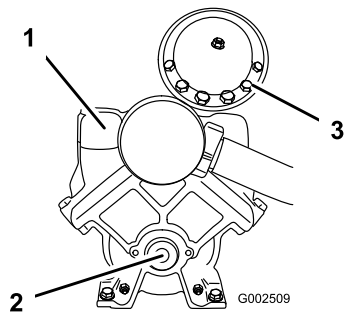

Figure 44

- 1. Pump
- 2. Grease fitting
- 3. Pressure Dampener

Adjusting the Air Pressure in Dampener

The air pressure in the dampener on the pump is set at 15 psi (1 bar) by the manufacturer. The recommended pressure in the dampener is 1/3 of the spraying pressure. If using a spray pressure greater than 45 psi (3.1 bar) adjust the dampener accordingly.

Maintenance

Note: Determine the left and right sides of the machine from the normal operating position.

Recommended Maintenance Schedule(s)

Maintenance Service Interval	Maintenance Procedure
Before each use or daily	<ul style="list-style-type: none"> • Clean the suction strainer. (More often when using wettable powders)
Every 50 hours	<ul style="list-style-type: none"> • Lubricate the pump.
Every 100 hours	<ul style="list-style-type: none"> • Lubricate the grease fittings. • Lubricate the boom hinges.
Every 200 hours	<ul style="list-style-type: none"> • Inspect all hoses and connections for damage and proper attachment. • Clean the flowmeter. (More often when using wettable powders)
Every 400 hours	<ul style="list-style-type: none"> • Grease the actuator rod bearings. • Inspect the O-rings in the valve assemblies and replace them if necessary. • Inspect the pump diaphragm and replace if necessary. (see an Authorized Toro Service Distributor) • Inspect the pressure dampener bladder and replace if necessary. (see an Authorized Toro Service Distributor) • Inspect the pump check valves and replace if necessary. (see an Authorized Toro Service Distributor) • Check boom actuator hydraulic oil for air bubbles. • Inspect the nylon pivot bushings.

Important: Refer to your Workman[®] and engine *Operator's Manual* for additional maintenance procedures.

Daily Maintenance Checklist

Duplicate this page for routine use.

Maintenance Check Item	For the week of:						
	Mon.	Tues.	Wed.	Thurs.	Fri.	Sat.	Sun.
Check the brake and parking brake operation.							
Check the gear shift/neutral operation.							
Check the fuel level.							
Check the engine oil level before filling the tank.							
Check the transaxle oil level before filling the tank.							
Inspect the air filter before filling the tank.							
Inspect the engine cooling fins before filling the tank.							
Check any unusual engine noises.							
Check any unusual operating noises.							
Check the tire pressure.							
Check for fluid leaks.							
Check the instrument operation.							
Check the accelerator operation.							

Maintenance Check Item	For the week of:						
	Mon.	Tues.	Wed.	Thurs.	Fri.	Sat.	Sun.
Clean the suction strainer.							
Check toe-in.							
Lubricate all grease fittings. ¹							
Touch up and damaged paint.							

¹Immediately after every washing, regardless of the interval listed

Notation for Areas of Concern

Inspection performed by:		
Item	Date	Information
1		
2		
3		
4		
5		
6		
7		
8		
9		
10		

⚠ CAUTION

If you leave the key in the ignition switch, someone could accidentally start the engine and seriously injure you or other bystanders.

Remove the key from the ignition and disconnect the wire(s) from the spark plug(s) before you do any maintenance. Set the wire(s) aside so that it does not accidentally contact the spark plug(s).

Premaintenance Procedures

Accessing the Machine

Raising the Tank Assembly

⚠ DANGER

The sprayer tank assembly represents a stored energy hazard. If not properly retained when installing or removing the assembly it can move or fall and injure you or other bystanders.

Use straps and an overhead lift to support the sprayer tank assembly during installation, removal or any maintenance when the retaining fasteners are being removed.

An **empty** tank assembly can be tipped or raised up to allow full access to the engine and other internal components. It is recommended to pivot the boom extension forward to distribute the weight more evenly. Use the following procedure

1. Park the vehicle with an **empty** tank on a level surface.
2. Use the boom control switches to raise the boom extension to approximately 45°. Then stop the machine, engage the parking brake and remove the key.
3. Remove the safety bolts from the front of the skid (Figure 45).

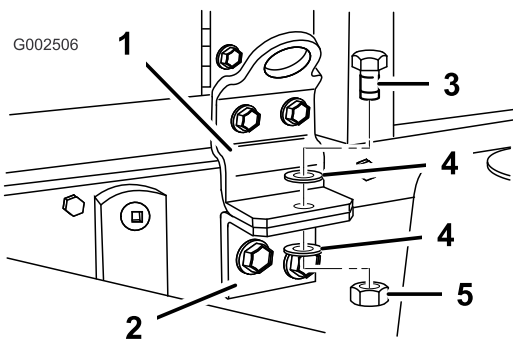

Figure 45
Left side shown

- | | |
|------------------------------|-----------------------|
| 1. Front mounting bracket | 4. Washer (1/2 inch) |
| 2. Hold-down bracket | 5. Locknut (1/2 inch) |
| 3. Bolt (1/2 x 1-1/2 inches) | |

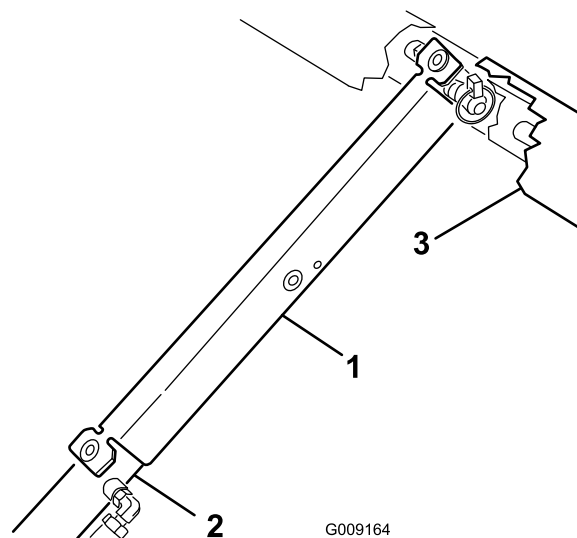

Figure 47

- | | |
|--------------------|--------|
| 1. Bed support | 3. Bed |
| 2. Cylinder barrel | |

- Fold the boom extensions forward, alongside the tank assembly to distribute the weight more evenly and keep it from tipping back.
- Raise the tank assembly until the lift cylinders are fully extended.
- Remove the bed support from the storage brackets on back of the ROPS panel (Figure 46).

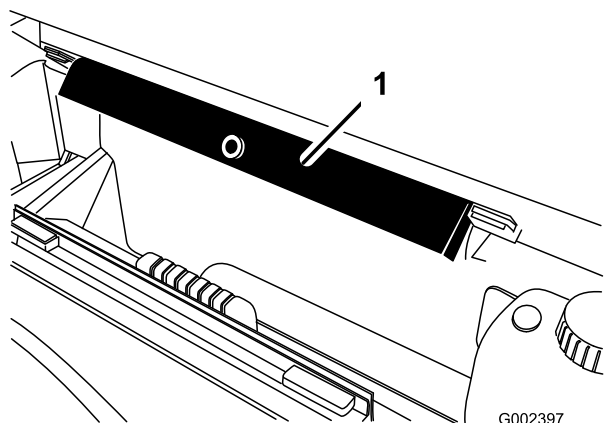

Figure 46

- Bed support

- Push the bed support onto the cylinder rod, making sure the support end tabs rest on the end of cylinder barrel and on the cylinder rod end (Figure 47).

Lowering the Tank Assembly

- When finished, remove the bed support from the cylinder and insert it into the brackets on the back of the ROPS panel.

CAUTION

Do not try to lower the tank assembly with bed safety support on cylinder.

- Retract the lift cylinders to carefully lower the tank to the frame.
- Install the two hold down bolts and fasteners to secure the tank assembly
- Fold the boom extensions rearward to the extended position.
- Use the boom control switches to raise the boom extensions to the transport position.

Lubrication

Greasing the Sprayer System

Service Interval: Every 50 hours

Every 100 hours

Lubricate all bearings and bushings after every 100 hours or once a year, whichever occurs first.

Grease Type: No. 2 General Purpose Lithium Base Grease

1. Wipe the grease fitting clean so that foreign matter cannot be forced into the bearing or bushing.
2. Pump grease into the bearing or bushing.
3. Wipe off excess grease.

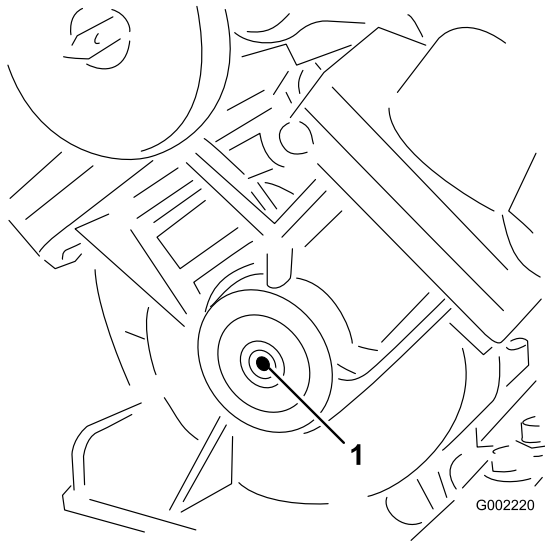

Figure 48

Pump (Do not over grease, grease will not purge)

1. Grease point

Greasing the Boom Hinges

Service Interval: Every 100 hours

Important: If the boom hinge is washed with water, all water and debris must be cleared from the hinge assembly and fresh grease must be applied.

Grease Type: No. 2 general-purpose lithium base grease.

1. Wipe the grease fittings clean so that foreign matter cannot be forced into the bearing or bushing.
2. Pump grease into the bearing or bushing at each fitting Figure 49.

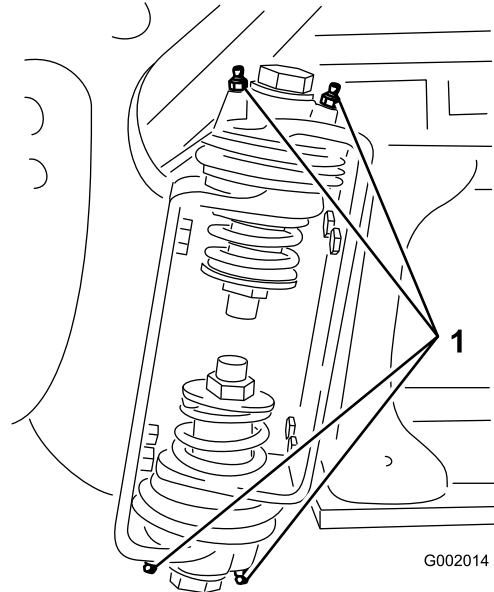

Figure 49
Right boom

1. Grease fitting

3. Wipe off excess grease.
4. Repeat the procedure for each boom pivot.

Greasing the Actuator Rod Bearings

Service Interval: Every 400 hours/Yearly (whichever comes first)

Grease Type: No. 2 general-purpose lithium base grease.

1. Extend the booms to the spray position.
2. Remove the cotter pin from the pivot pin (Figure 50).

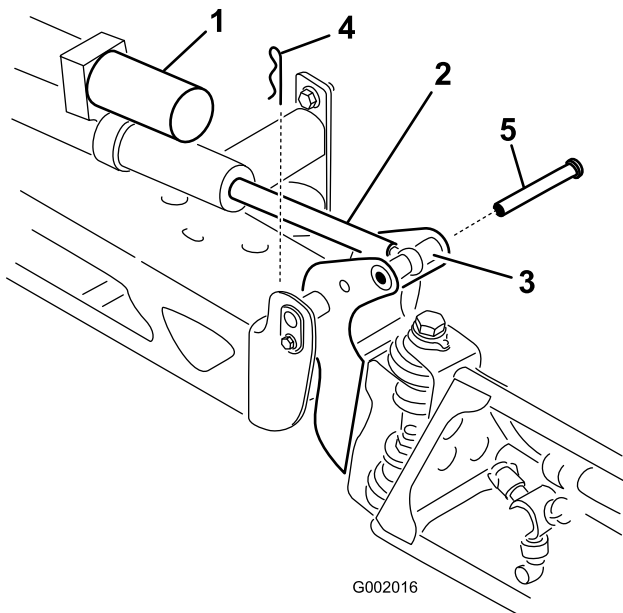

Figure 50

- | | |
|---------------------------|-----------|
| 1. Actuator | 4. Cotter |
| 2. Actuator rod | 5. Pin |
| 3. Boom pivot pin housing | |

7. With the pin in place, release the boom and secure the pin with the cotter removed previously.
8. Repeat the procedure for each actuator rod bearing.

3. Lift up on the boom and remove the pin (Figure 50). Slowly lower the boom to the hardstop.
4. Inspect the pin for any damage, replace if necessary.
5. Manipulate the actuator rod bearing end and apply grease into the bearing (Figure 51). Wipe off excess grease.

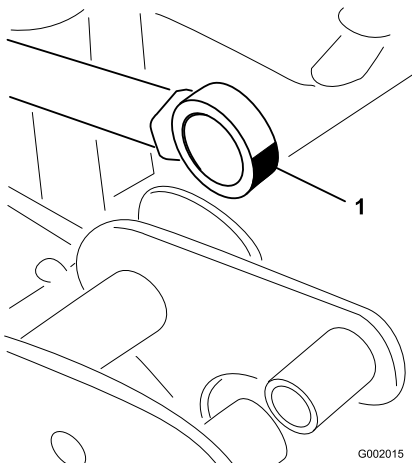

Figure 51
Right boom

1. Grease bearing

6. Lift up on the boom to align the pivot with the actuator rod. While holding the boom, insert the pin through both boom pivot and actuator rod (Figure 50).

Electrical System Maintenance

Fuses

The Workman® 200 Spray System adds a fuse block to the vehicles existing electrical system. It is located beneath dashboard with the existing fuse block(s).

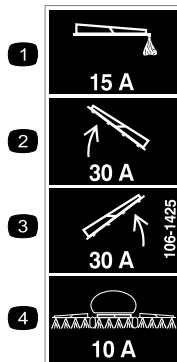

Figure 52

- | | |
|-------------------------------------|--------------------------------------|
| 1. Foam marker (optional), 15A | 3. Thermal Breaker, right boom, 30 A |
| 2. Thermal Breaker, left boom, 30 A | 4. Spray system, 10A |

The two thermal breakers accommodate the left and right actuators independently. They can disrupt power to the actuators when overheated to avoid damaging the internal motor of the actuators.

Note: Once the thermal breaker has been tripped the system must be allowed to cool down before operation to resume.

Spray System Maintenance

Inspecting the Hoses

Service Interval: Every 200 hours

Every 400 hours/Yearly (whichever comes first)

Examine each hose in the spray system for cracks, leaks or other damage. At the same time, inspect the connections and fittings for similar damage. Replace any hoses and fittings if damaged.

Pump Maintenance

Inspecting the Pump

Service Interval: Every 400 hours/Yearly (whichever comes first)—Inspect the pump diaphragm and replace if necessary. (see an Authorized Toro Service Distributor)

Every 400 hours/Yearly (whichever comes first)—Inspect the pressure dampener bladder and replace if necessary. (see an Authorized Toro Service Distributor)

Every 400 hours/Yearly (whichever comes first)—Inspect the pump check valves and replace if necessary. (see an Authorized Toro Service Distributor)

Note: The following machine components are considered parts subject to consumption through use unless found defective and are not covered by the Warranty associated with this machine.

Have an Authorized Toro Service Distributor check following internal pump components for damage:

- Pump diaphragm
- Pressure dampener bladder
- Pump check valves assemblies

Replace any components if necessary.

Adjusting the Air Pressure in Dampener

The air pressure in the dampener on the pump is set at 15 psi (1 bar) by the manufacturer. The recommended pressure in the dampener is 1/3 of the spraying pressure. If using a spray pressure greater than 45 psi (3.1 bar) adjust the dampener accordingly.

Adjusting the Boom Actuator

Service Interval: Every 400 hours

Inspect the actuator hydraulic oil for air bubbles every 400 hours.

1. Position the sprayer on a level surface, lower the booms into the spray position.
2. Set the parking brake, stop the pump, stop the engine, and remove the ignition key
3. Attempt to lift the boom by applying a moderate amount of pressure (just enough to lift the boom manually) while observing the actuator rod. If the actuator rod exhibits movement refer to below.
4. Repeat the procedure for the opposing boom.

If the actuator rod exhibits an axial movement (travels into or out of the cylinder) greater than 0.085-0.100 inch (2.16-2.54 mm), you may wish to bleed the air from the hydraulic oil.

Refer to the *Service Manual* for instructions on how to bleed air from the actuators or contact an Authorized Toro Service Distributor.

Emergency Manual Operation of the Boom Actuators

Note: Determine the left and right sides of the machine from the normal operating position.

▲ DANGER

Use of the manual relief valve may cause the boom to move suddenly and cause injury to you or others.

- Take caution and adjust the manual relief valve slowly.
- Ensure the surrounding area is clear and no one is inside the operating range of the boom.

▲ CAUTION

Adjusting the manual relief valve with electrical power present could cause the actuator operate irregularly and cause injury to you or others.

Do not use the manual relief valve while electrical power is being supplied to the actuator.

In case of an emergency such that the boom must be moved and no 12V DC power source is available, the manual relief valve can be used to relieve pressure within the actuator and allow the booms to be moved manually.

Important: The manual valve must not be loosened more than 4 turns. Turning the valve more than 4 turns may cause the valve to come off completely allowing hydraulic oil to spill out.

1. Locate the manual relief valve on the actuator for each boom. The manual relief valve is the smaller valve and is only on one side of the actuator body (Figure 53).

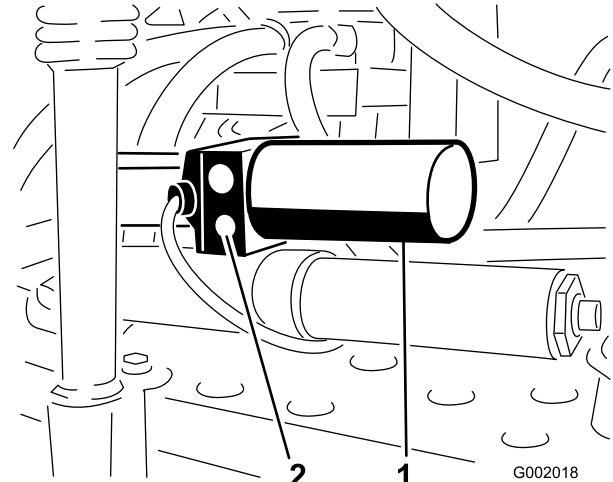

Figure 53

1. Actuator, right boom
2. Manual relief valve

Note: Due to the opposing orientation of actuators in respect to each other the manual relief valve is on the forward face of the left boom actuator and the rear face of the right boom actuator.

2. Use a hexagonal wrench to loosen the manual relief valve **no more** than 2-3 turns. The cylinder should start stroking manually or by external pressure at this time.
3. Once the original position of the actuator is recovered, close the manual relief valve. Torque the valve to 1.1-2.1 ft-lb (1.5-2.9 N·m).

Inspecting the Nylon Pivot Bushings

Service Interval: Every 400 hours/Yearly (whichever comes first)

1. Position the sprayer on a level surface, set the parking brake, stop the pump, stop the engine, and remove the ignition key.
2. Extend the booms to the spray position and support the booms using stands or straps from a lift.
3. With the weight of the boom supported, remove the bolt and nut securing the pivot pin to the boom assembly (Figure 54). Remove the pivot pin.

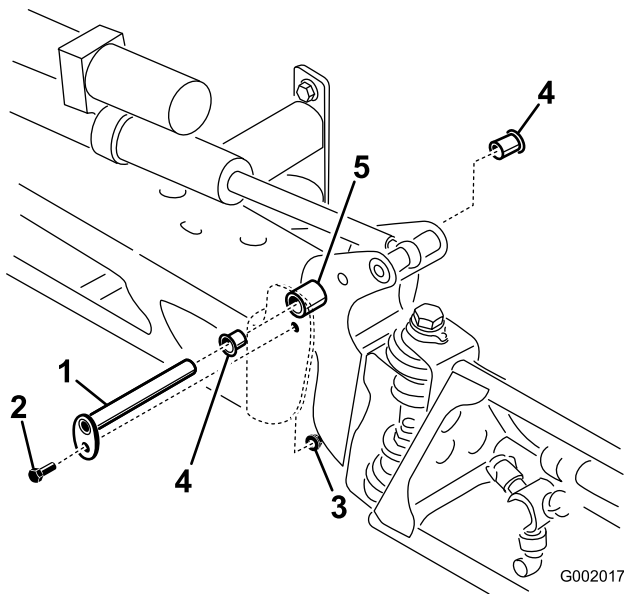

Figure 54

- | | |
|--------------|------------------|
| 1. Pivot pin | 4. Nylon bushing |
| 2. Bolt | 5. Pivot bracket |
| 3. Nut | |

4. Remove the boom and pivot bracket assembly from the center frame to access the nylon bushings.
5. Remove and inspect the nylon bushings from the front and back sides of the pivot bracket (Figure 54). Replace any damaged bushings.
6. Place a small amount of oil on the nylon bushings and install them into pivot bracket.
7. Install the boom and pivot bracket assembly into the center frame, aligning the openings (Figure 54).
8. Install the pivot pin and secure it with the bolt and nut removed previously.

Repeat the procedure for each boom.

Cleaning

Cleaning the Flowmeter

Service Interval: Every 200 hours/Yearly (whichever comes first) (More often when using wettable powders)

1. Thoroughly rinse and drain the entire spraying system.
2. Remove the flowmeter from the sprayer and flush it with clean water.
3. Remove the retainer ring on the upstream side (Figure 55).

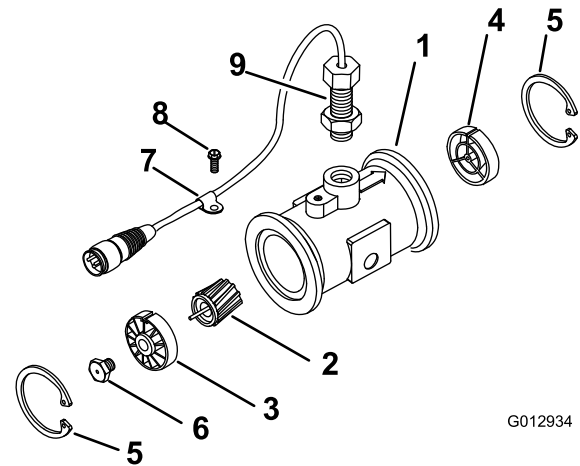

Figure 55

- | | |
|----------------------------------|--------------------------|
| 1. Modified flanged body | 6. Turbine stud assembly |
| 2. Rotor/ magnet assembly | 7. Cable clamp |
| 3. Hub/ bearing assembly | 8. Thread screw |
| 4. Hub assembly (with keyway up) | 9. Sensor assembly |
| 5. Retaining ring | 10. Flow-reducing sleeve |

4. Clean the turbine and the turbine hub to remove metal filings and any wettable powders.

5. Inspect the turbine blades for wear.

Note: Hold the turbine in your hand and spin it. It should spin freely with very little drag. If it does not, replace it.

6. Assemble the flowmeter.

7. Use a low pressure (5 psi or 50 kPa) air jet to ensure that the turbine spins freely. If it does not, loosen the hex stud on the bottom of the turbine hub by 1/16 of a turn until the turbine spins freely.

Cleaning the Suction Strainer

Service Interval: Before each use or daily

1. Position the sprayer on a level surface, set the parking brake, stop the pump, stop the engine, and remove the ignition key.
2. Remove the retainer from the red fitting attached to the large hose on the top of the tank (Figure 56).

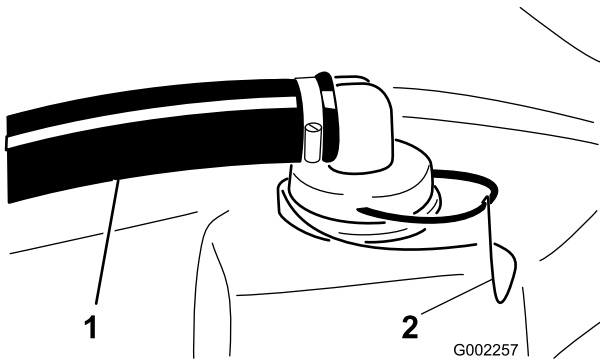

Figure 56

1. Suction hose
2. Retainer

3. Disconnect the hose from the tank (Figure 56).
4. Pull the suction strainer out of the hole (Figure 57).

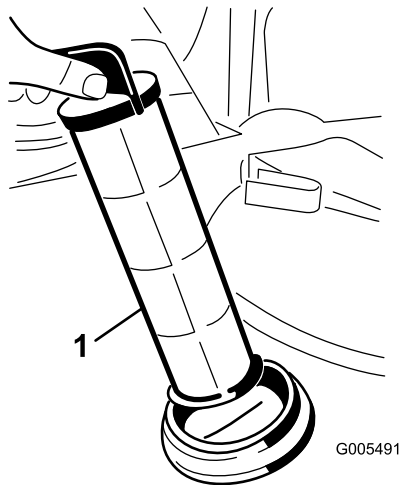

Figure 57

1. Suction strainer

5. Clean the suction strainer with clean running water.
6. Replace the suction strainer, seating it fully into the hole.
7. Connect the hose to the top of the tank and secure it with the retainer.

Storage

1. Position the sprayer on a level surface, set the parking brake, disengage the PTO, stop the engine, and remove the ignition key.
2. Clean dirt and grime from the entire machine, including the outside of the engine's cylinder head fins and blower housing.

Important: You can wash the machine with mild detergent and water. Do not use high pressure water to wash the machine. Pressure washing may damage the electrical system or wash away necessary grease at friction points. Avoid excessive use of water, especially near the control panel, lights, engine, and the battery.

3. Clean the spray system; refer to the Cleaning section.
4. Add a rust inhibiting, non-alcohol based, RV antifreeze solution to the system and run the pump for a few minutes to circulate it through the system, then drain the spray system as completely as possible.
5. Use the boom lift switches to raise the booms. Raise the booms until have moved completely into boom transport cradle forming the "X" transport position and the boom cylinders are fully retracted. Make sure the boom cylinders are fully retracted to prevent actuator rod damage.
6. Inspect the brakes; refer to the *Workman Operator's Manual*.
7. Service the air cleaner; refer to the *Workman Operator's Manual*.
8. Grease the sprayer; refer to the Lubrication section.
9. Check and tighten all bolts, nuts, and screws. Repair or replace any part that is damaged.
10. Check the condition of all spray hoses, replacing any that are damaged or worn.
11. Tighten all hose fittings.
12. Paint all scratched or bare metal surfaces.
Paint is available from your Authorized Service Dealer.
13. Store the machine in a clean, dry garage or storage area.
14. Cover the machine to protect it and keep it clean.

Removing the Sprayer

If removing the sprayer from the Workman vehicle, use the following procedure and reference the Setup section.

⚠ DANGER

The sprayer tank assembly represents a stored energy hazard. If not properly retained when installing or removing the assembly it can move or fall and injure you or other bystanders.

Use straps and an overhead lift to support the sprayer tank assembly during installation, removal or any maintenance when the retaining fasteners are being removed.

1. Secure and support the sprayer tank assembly with straps to an overhead lift using the eyelets on the skid frame. This prevents the assembly from shifting when the fasteners securing the tank assembly to the frame are loosened.
2. Lower booms to approximately 45° and then pivot them forward.
3. Disconnect the wire harness and PTO shaft.
4. Store the control box, using the existing fasteners, to the left, rear of the tank skid.
5. Remove all the fasteners retaining the sprayer tank assembly to the machine frame. Retain all parts.
6. Lift the tank assembly 3-4 inches and remove the lynch pins and clevis pins securing the lift cylinders to the tank assembly.
7. Retract the lift cylinders and return them to their holders on the vehicle frame. Lift the tank assembly clear of the vehicle.
8. When the sprayer tank assembly is clear of the vehicle, insert the four jack stands provided and lock the jack stands with the clevis pins provided.
9. Move the vehicle out of the way.

Troubleshooting

Troubleshooting the Spray System

Problem	Possible Cause	Corrective Action
A boom section does not spray.	<ol style="list-style-type: none"> 1. The electrical connection on the boom valve is dirty or disconnected. 2. Blown fuse 3. Pinched hose 4. A boom by-pass valve is improperly adjusted. 5. Damaged boom valve 6. Damaged electrical system 	<ol style="list-style-type: none"> 1. Turn the valve off manually. Disconnect the electrical connector on the valve and clean all leads, then reconnect it. 2. Check the fuses and replace them as necessary. 3. Repair or replace the hose. 4. Adjust the boom by-pass valves. 5. Contact your Authorized Service Dealer. 6. Contact your Authorized Service Dealer.
A boom section does not turn off.	<ol style="list-style-type: none"> 1. The valve is damaged. 	<ol style="list-style-type: none"> 1. Stop the spray system and pump and turn off the sprayer. Remove the retainer from under the boom valve and pull out the motor and stem. Inspect all parts and replace any that appear damaged.
A boom valve is leaking	<ol style="list-style-type: none"> 1. An O-ring is deteriorated. 	<ol style="list-style-type: none"> 1. Stop the spray system and pump and turn off the sprayer. Disassemble the valve and replace the O-rings.
A pressure drop occurs when you turn on a boom.	<ol style="list-style-type: none"> 1. The boom bypass valve is improperly adjusted. 2. There is an obstruction in the boom valve body. 3. A nozzle filter is damaged or clogged. 	<ol style="list-style-type: none"> 1. Adjust the boom bypass valve. 2. Remove the inlet and outlet connections to the boom valve and remove any obstructions. 3. Remove and inspect all nozzles.
Boom actuator is not operating properly.	<ol style="list-style-type: none"> 1. A thermal breaker in the fuse block responsible for powering the actuator has tripped due to overheating. 2. A thermal breaker in the boom actuator responsible for powering the actuator has tripped or malfunctioned. 	<ol style="list-style-type: none"> 1. Wait for the system to cool down before resuming operation. If the thermal breaker trip repeatedly, contact your Authorized Service Dealer. 2. Contact your Authorized Service Dealer.

Troubleshooting the Spray Pro Monitor

Problem	Possible Cause	Corrective Action
The monitor does not function.	<ol style="list-style-type: none"> 1. The monitor cable is loose or disconnected. 2. The monitor or cable is damaged. 	<ol style="list-style-type: none"> 1. Connect the monitor cable. 2. Contact your Authorized Service Dealer.
The Speed is always 0 or erratic.	<ol style="list-style-type: none"> 1. The monitor cable is loose. 2. The speed sensor is not calibrated correctly. 3. The speed sensor is damaged. 	<ol style="list-style-type: none"> 1. Connect the monitor cable. 2. Calibrate the speed sensor. 3. Contact your Authorized Service Dealer.

Problem	Possible Cause	Corrective Action
The Area is inaccurate.	<ol style="list-style-type: none"> 1. The sprayer width is not correctly entered. 2. The speed sensor is not calibrated correctly. 3. The speed sensor is damaged. 	<ol style="list-style-type: none"> 1. Check and set the appropriate Width in the calibration mode. 2. Calibrate the speed sensor. 3. Contact your Authorized Service Dealer.
The Distance is inaccurate.	<ol style="list-style-type: none"> 1. The speed sensor is not calibrated correctly. 2. The speed sensor is damaged. 	<ol style="list-style-type: none"> 1. Calibrate the speed sensor. 2. Contact your Authorized Service Dealer.
The monitor does not display Application Rate or Total Volume.	<ol style="list-style-type: none"> 1. The monitor cable is loose. 2. The flow meter is dirty or clogged. 3. The flow meter is not calibrated correctly. 4. The flow meter is damaged. 	<ol style="list-style-type: none"> 1. Connect the monitor cable. 2. Clean the flow meter. 3. Calibrate the flow meter. 4. Contact your Authorized Service Dealer.
The Total Volume is inaccurate.	<ol style="list-style-type: none"> 1. The flow meter is dirty or clogged. 2. The flow meter is not calibrated correctly. 3. The flow meter is damaged. 	<ol style="list-style-type: none"> 1. Clean the flow meter. 2. Calibrate the flow meter. 3. Contact your Authorized Service Dealer.
The monitor displays 6553.5 when in the Application Rate setting.	<ol style="list-style-type: none"> 1. The monitor is not receiving data from the speed sensor. 	<ol style="list-style-type: none"> 1. Contact your Authorized Service Dealer.
The monitor is erratic in operation.	<ol style="list-style-type: none"> 1. A two-way radio is too close to the monitor or its cables. 	<ol style="list-style-type: none"> 1. Keep two-way radios away from the monitor and its cables.
The displayed measurements do not make sense.	<ol style="list-style-type: none"> 1. The Units of Measurement is set to a system other than what you expect. 	<ol style="list-style-type: none"> 1. Check the Units of Measurement to ensure that it is set correctly.
The monitor reads "OFL."	<ol style="list-style-type: none"> 1. The data has exceeded the maximum allowed. 	<ol style="list-style-type: none"> 1. Press and hold the [Reset] button to clear the monitor.

Schematics

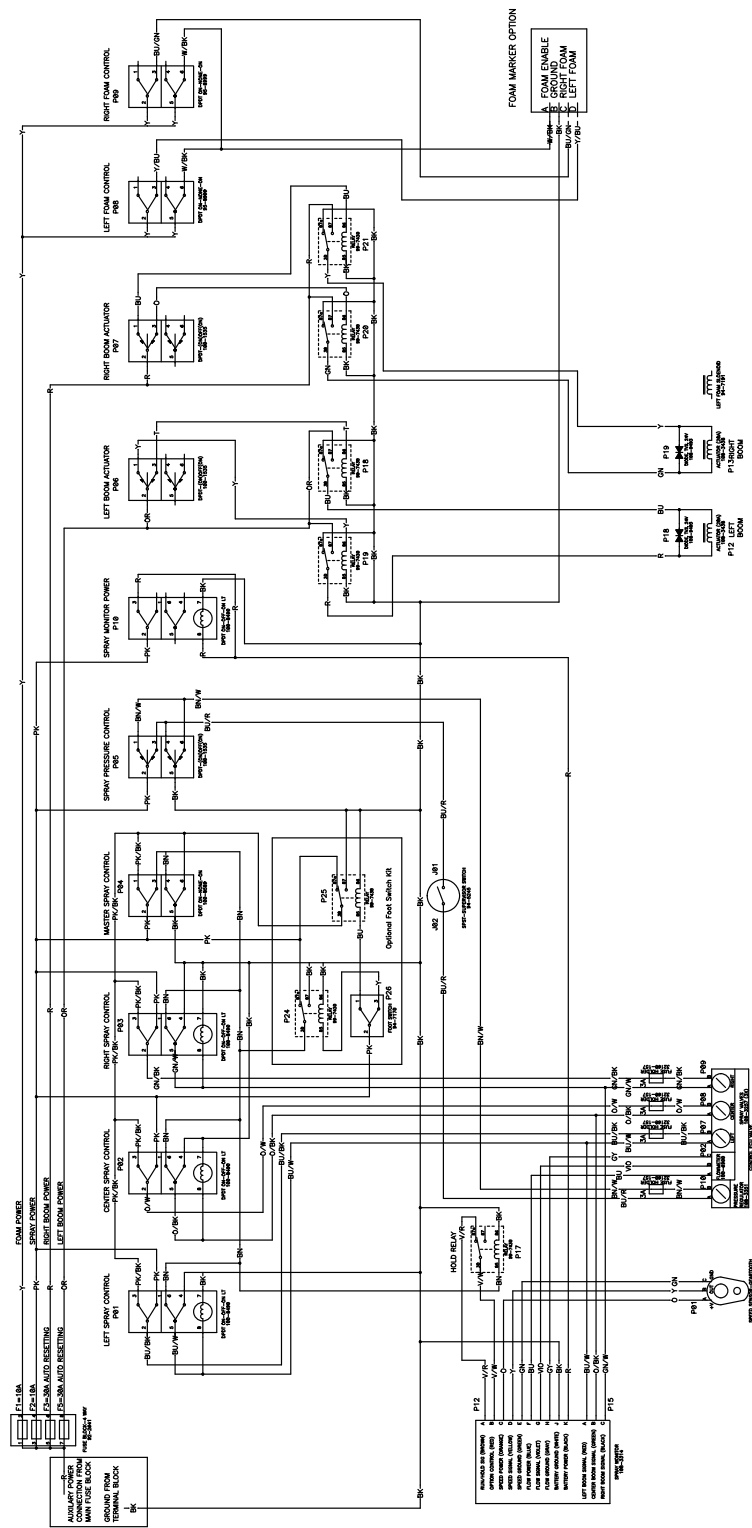

Electrical, spray system (Rev. A)

G011797



The Toro Total Coverage Guarantee

A Limited Warranty

Conditions and Products Covered

The Toro® Company and its affiliate, Toro Warranty Company, pursuant to an agreement between them, jointly warrant your Toro Commercial product ("Product") to be free from defects in materials or workmanship for two years or 1500 operational hours*, whichever occurs first. This warranty is applicable to all products with the exception of Aerators (refer to separate warranty statements for these products). Where a warrantable condition exists, we will repair the Product at no cost to you including diagnostics, labor, parts, and transportation. This warranty begins on the date the Product is delivered to the original retail purchaser.

* Product equipped with an hour meter.

Instructions for Obtaining Warranty Service

You are responsible for notifying the Commercial Products Distributor or Authorized Commercial Products Dealer from whom you purchased the Product as soon as you believe a warrantable condition exists. If you need help locating a Commercial Products Distributor or Authorized Dealer, or if you have questions regarding your warranty rights or responsibilities, you may contact us at:

Commercial Products Service Department
Toro Warranty Company
8111 Lyndale Avenue South
Bloomington, MN 55420-1196
E-mail: commercial.warranty@toro.com

Owner Responsibilities

As the Product owner, you are responsible for required maintenance and adjustments stated in your Operator's Manual. Failure to perform required maintenance and adjustments can be grounds for disallowing a warranty claim.

Items and Conditions Not Covered

Not all product failures or malfunctions that occur during the warranty period are defects in materials or workmanship. This warranty does not cover the following:

- Product failures which result from the use of non-Toro replacement parts, or from installation and use of add-on, or modified non-Toro branded accessories and products. A separate warranty may be provided by the manufacturer of these items.
- Product failures which result from failure to perform recommended maintenance and/or adjustments. Failure to properly maintain your Toro product per the Recommended Maintenance listed in the *Operator's Manual* can result in claims for warranty being denied.
- Product failures which result from operating the Product in an abusive, negligent or reckless manner.
- Parts subject to consumption through use unless found to be defective. Examples of parts which are consumed, or used up, during normal Product operation include, but are not limited to, brakes pads and linings, clutch linings, blades, reels, bed knives, tines, spark plugs, castor wheels, tires, filters, belts, and certain sprayer components such as diaphragms, nozzles, and check valves, etc.
- Failures caused by outside influence. Items considered to be outside influence include, but are not limited to, weather, storage practices, contamination, use of unapproved coolants, lubricants, additives, fertilizers, water, or chemicals, etc.

Countries Other than the United States or Canada

Customers who have purchased Toro products exported from the United States or Canada should contact their Toro Distributor (Dealer) to obtain guarantee policies for your country, province, or state. If for any reason you are dissatisfied with your Distributor's service or have difficulty obtaining guarantee information, contact the Toro importer. If all other remedies fail, you may contact us at Toro Warranty Company.

- Normal noise, vibration, wear and tear, and deterioration.
- Normal "wear and tear" includes, but is not limited to, damage to seats due to wear or abrasion, worn painted surfaces, scratched decals or windows, etc.

Parts

Parts scheduled for replacement as required maintenance are warranted for the period of time up to the scheduled replacement time for that part. Parts replaced under this warranty are covered for the duration of the original product warranty and become the property of Toro. Toro will make the final decision whether to repair any existing part or assembly or replace it. Toro may use remanufactured parts for warranty repairs.

Note Regarding Deep Cycle Battery Warranty:

Deep cycle batteries have a specified total number of kilowatt-hours they can deliver during their lifetime. Operating, recharging, and maintenance techniques can extend or reduce total battery life. As the batteries in this product are consumed, the amount of useful work between charging intervals will slowly decrease until the battery is completely worn out. Replacement of worn out batteries, due to normal consumption, is the responsibility of the product owner. Battery replacement may be required during the normal product warranty period at owner's expense.

Maintenance is at Owner's Expense

Engine tune-up, lubrication cleaning and polishing, replacement of Items and Conditions Not Covered filters, coolant, and completing Recommended Maintenance are some of the normal services Toro products require that are at the owner's expense.

General Conditions

Repair by an Authorized Toro Distributor or Dealer is your sole remedy under this warranty.

Neither The Toro Company nor Toro Warranty Company is liable for indirect, incidental or consequential damages in connection with the use of the Toro Products covered by this warranty, including any cost or expense of providing substitute equipment or service during reasonable periods of malfunction or non-use pending completion of repairs under this warranty. Except for the Emissions warranty referenced below, if applicable, there is no other express warranty.

All implied warranties of merchantability and fitness for use are limited to the duration of this express warranty. Some states do not allow exclusions of incidental or consequential damages, or limitations on how long an implied warranty lasts, so the above exclusions and limitations may not apply to you.

This warranty gives you specific legal rights, and you may also have other rights which vary from state to state.

Note regarding engine warranty:

The Emissions Control System on your Product may be covered by a separate warranty meeting requirements established by the U.S. Environmental Protection Agency (EPA) and/or the California Air Resources Board (CARB). The hour limitations set forth above do not apply to the Emissions Control System Warranty. Refer to the Engine Emission Control Warranty Statement printed in your *Operator's Manual* or contained in the engine manufacturer's documentation for details