

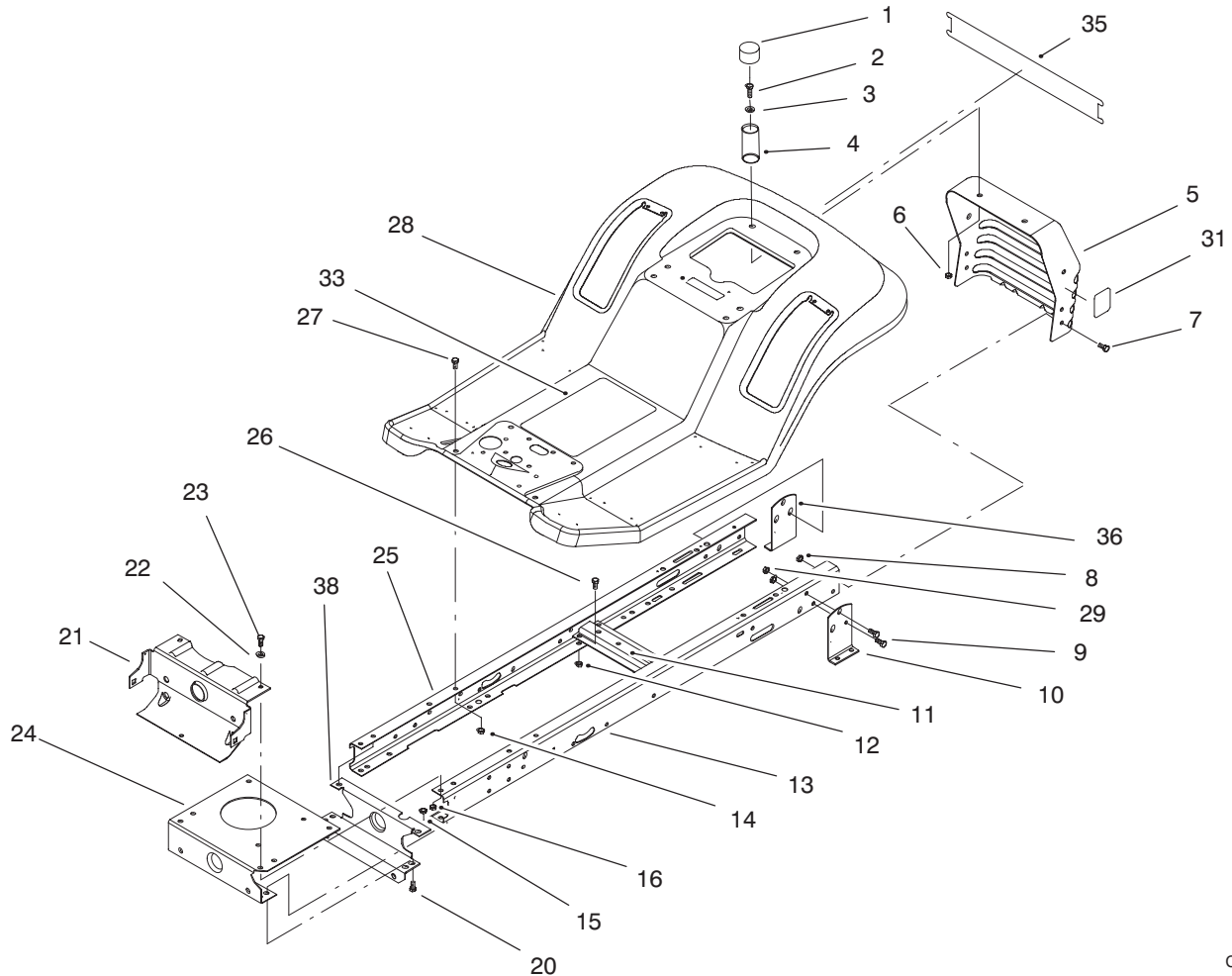

MODEL NO. 71218-690001 & UP

PARTS CATALOG

1644HXL LAWN TRACTOR



C-2431

FRAME ASSEMBLY

Ref. No.	Part No.	Description	No. Used
1	701178	Cap - Protector	2
2	322-5	Screw - Hex Hd. Cap	2
3	3256-23	Washer - Flat	2
4	88-6220	Spring - Compression	2
5	88-3940	Panel - Rear Hitch	1
6	3296-29	Nut - Lock	2
7	322-3	Screw - Hex Hd. Cap	4
8	3296-29	Nut - Lock	4
9	322-3	Screw - Hex Hd. Cap	4
10	93-3857	Bracket - Trans. Mtg. L.H.	1
11	88-4620	Bracket - Idler Pivot	1
12	3296-29	Nut - Hex Lock	4
13	94-1999	Frame - Rail L.H.	1
14	3296-29	Nut - Lock	2
15	3296-29	Nut - Lock	6
16	3296-29	Nut - Lock	2

Ref. No.	Part No.	Description	No. Used
20	322-3	Screw - Hex Hd. Cap	6
21	93-3834	Support - Front Axle	1
22	3256-23	Washer - Flat	2
23	322-3	Screw - Hex Hd. Cap	2
24	88-4630	Plate - Engine Mounting	1
25	94-1998	Frame - Rail R.H.	1
26	322-3	Screw - Hex Hd. Cap	4
27	322-3	Screw - Hex Hd. Cap	2
28	88-3840	Body - Rear	1
29	3296-29	Nut - Lock	4
31	93-6678	Decal - Dump Valve Hydro	1
33	93-6676	Decal - Instruction	1
35	94-3530	Decal - Rear Body 1644	1
36	93-3856	Bracket - Trans. Mtg. R.H.	1
38	93-3831	Support - Rear	1

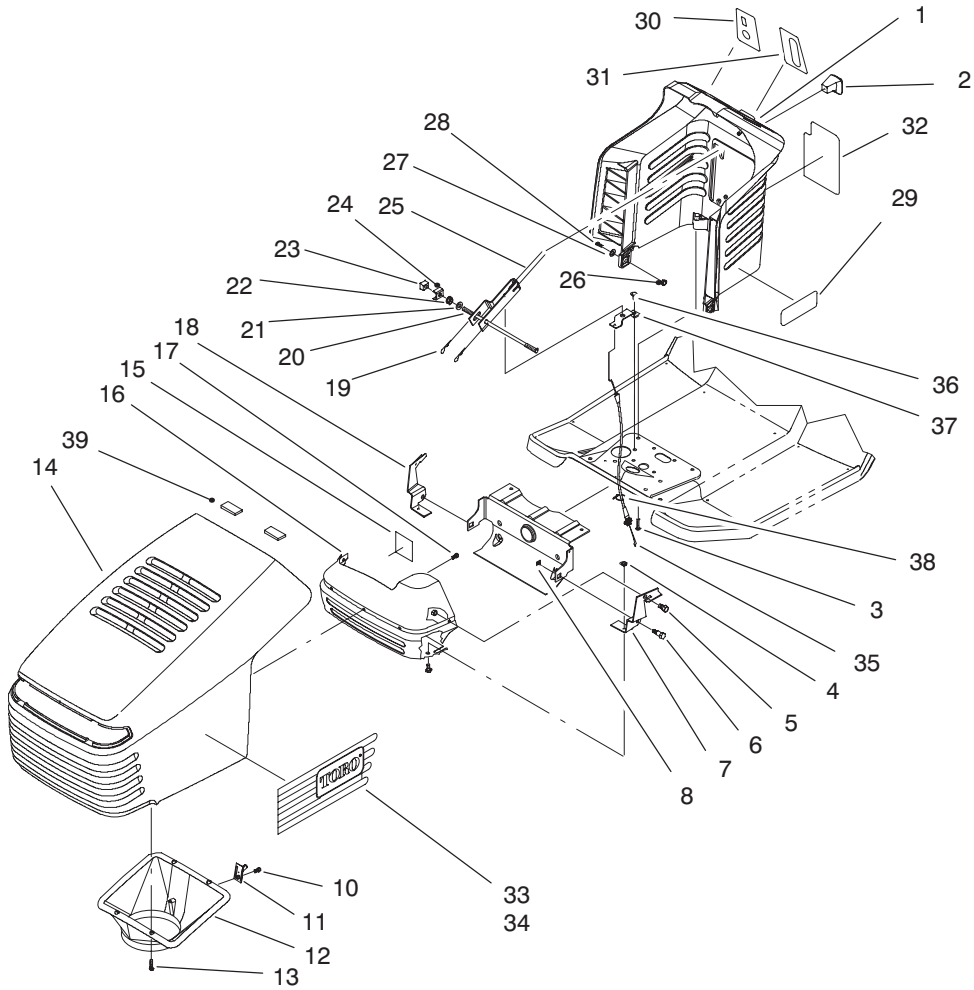

C-2432

HOOD ASSEMBLY

Ref. No.	Part No.	Description	No. Used
1	93-0303	Tower - Steering	1
2	94-5565	Knob - Control	1
3	46-8091	Screw - Tapping	2
4	3296-42	Nut - Lock	4
5	321-2	Screw - Hex Hd. Cap	4
6	28-0540	Bolt - Shoulder	2
7	88-6050	Bracket - Hinge L.H.	1
8	3290-496	Nut - Retained	2
10	46-8091	Screw - Plastic	1
11	94-1984	Pin - Latch	1
12	93-3891	Duct - Hood Air	1
13	46-8090	Screw - Plastic	4
14	92-8650	Hood - TORO	1
15	92-5782	Patch - Head Tape	1
16	93-3864	Shield - Heat	1
17	46-8090	Screw - Plastic	3
18	88-6040	Bracket - Hinge R.H.	1
19	3290-307	Pin - Hairpin Cotter	2
20	88-4170	Rod - Pivot Tower	1

Ref. No.	Part No.	Description	No. Used
21	3256-24	Washer - Flat	2
22	32128-43	Nut - Flange	2
23	88-4140	Nut - Wedge	2
24	88-4160	Clamp - Pivot Rod	2
25	88-5190	Lever - Deck Engage	1
26	3296-29	Nut - Lock	2
27	3256-23	Washer - Flat	2
28	322-3	Screw - Hex Hd. Cap	2
29	94-3528	Decal - Tower 1544HXL	2
30	92-5731	Decal - Ignition/Lights Int'l	1
31	92-5730	Decal - Throttle Int'l	1
32	93-6673	Decal - Deck Engage Int'l	1
33	92-2468	Decal - Hood L.H.	1
34	92-2467	Decal - Hood R.H.	1
35	94-4292	Cable - Deck Engage	1
36	32144-4	Screw - Tapping	2
37	93-3849	Bracket - Cable Upper	1
38	614249	Strap - Tie	1
39	94-1980	Foam - Hood	2

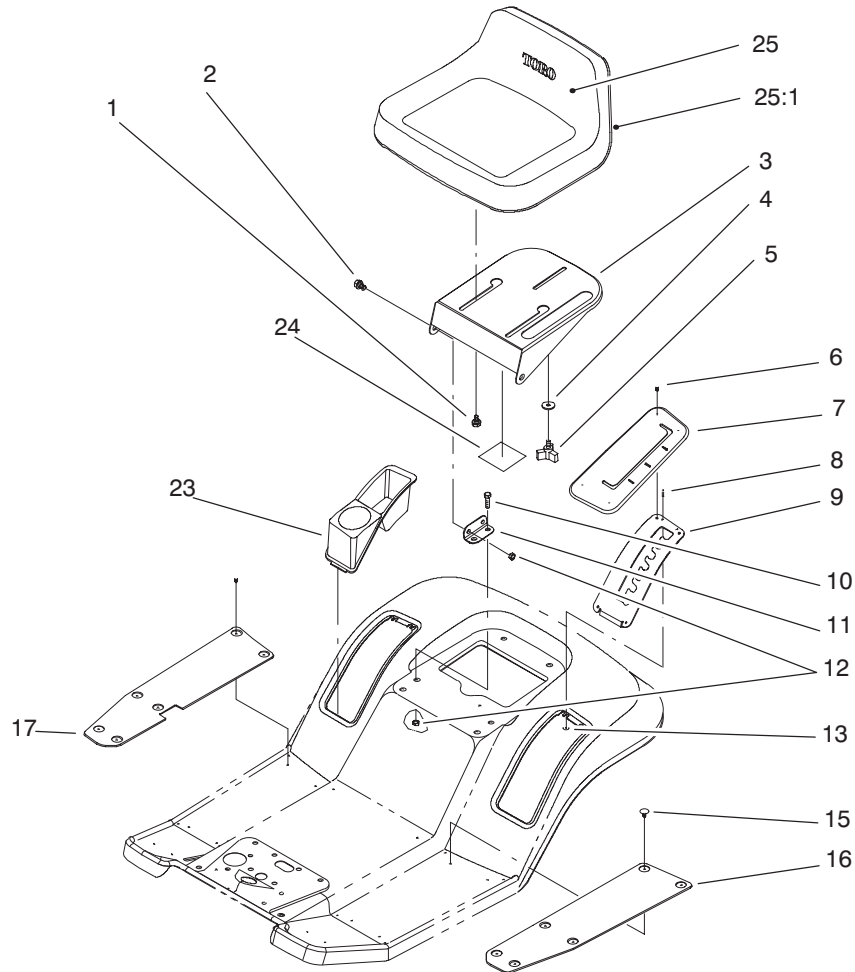

C-2306

SEAT ASSEMBLY

Ref. No.	Part No.	Description	No. Used	Ref. No.	Part No.	Description	No. Used
1	37-8770	Bolt - Shoulder	2	12	3296-29	Nut - Lock	6
2	37-8770	Bolt - Shoulder	2	13	3269-26	Washer	2
3	88-4910	Support - Seat	1	15	3290-479	Fastener - Panel	12
4	5-4460	Washer - Fender	1	16	88-5240	Mat - Foot L.H.	1
5	92-9674	Knob - Studded	1	17	88-5230	Mat - Foot R.H. Hydro	1
6	3290-479	Fastener - Panel	4	23	88-4990	Tray - Fender	1
7	93-7657	Cover - H.O.C. Int'l	1	24	114621	Decal - Noise Europe	1
8	3290-282	Rivet - Pop	2	25	92-6511	Seat - High Back V511 (Incl. Ref. #25:1)	1
9	88-5030	Gate - H.O.C.	1	25:1	94-4909	Trim - Seat	1
10	322-3	Screw - Hex Hd. Cap	4				
11	88-4820	Bracket - Seat Hinge	2				

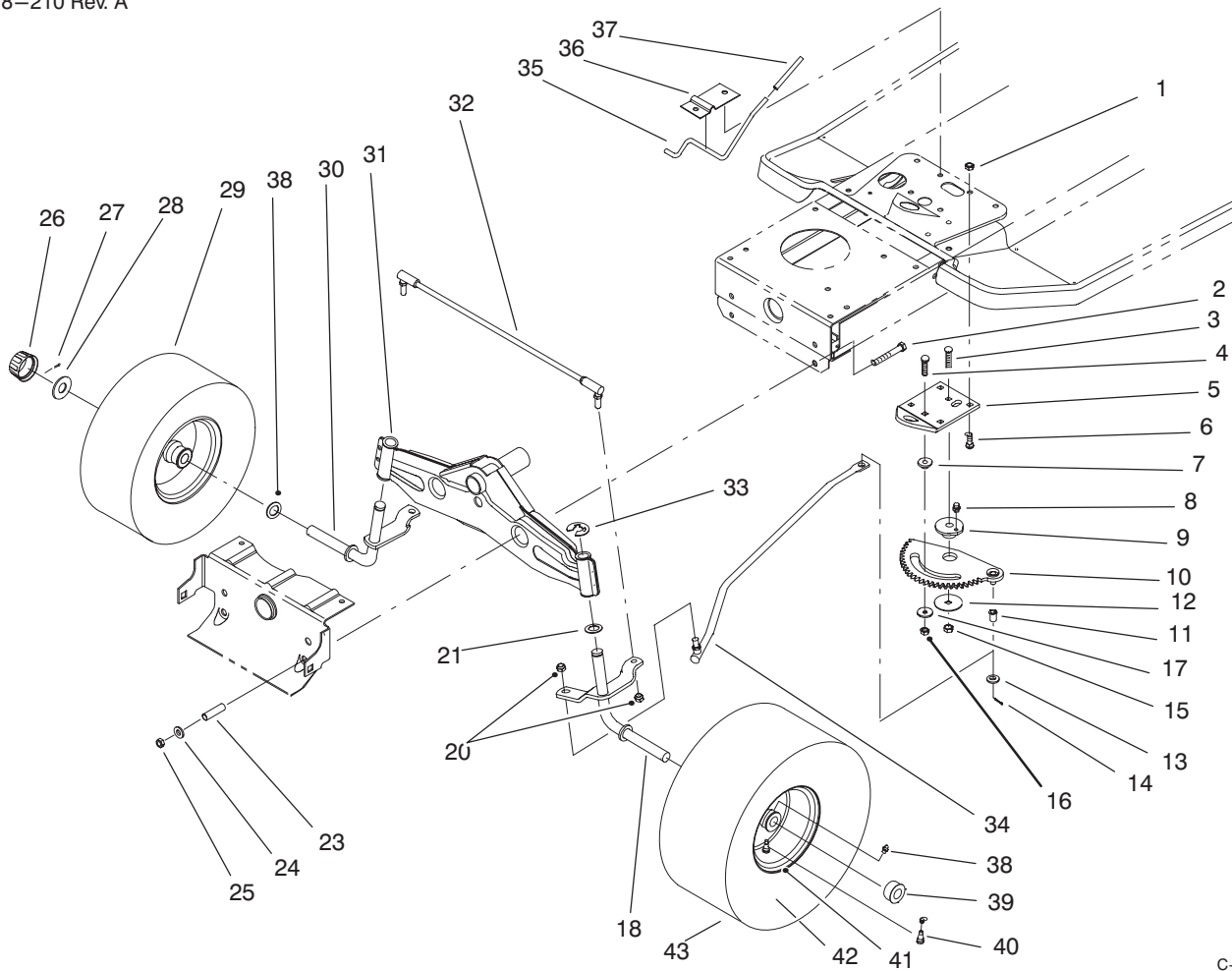

C-2307

FRONT AXLE ASSEMBLY

Ref. No.	Part No.	Description	No. Used
1	3296-29	Nut - Lock	4
2	323-13	Screw - Hex Hd. Cap	2
3	3231-4	Screw - Carriage	1
4	3230-3	Screw - Carriage	1
5	88-5130	Bracket - Steering Rack	1
6	3230-1	Screw - Carriage	4
7	88-5010	Spacer - Steering Rack	1
8	302-26	Fitting - Grease	1
9	88-4670	Bushing - Eccentric	1
10	88-5200	Rack - Steering	1
11	52-2891	Bushing - Steering Links	1
12	111419	Washer - Bearing	1
13	3256-25	Washer - Flat	1
14	3272-10	Pin - Cotter	1
15	3296-39	Nut - Lock	1
16	3296-29	Nut - Lock	1
17	5-4460	Washer - Fender	1
18	93-3833	Spindle - L.H.	1
20	3296-5	Nut - Lock	3
21	3-6498	Washer - Thrust	2
23	88-5470	Spacer - Front Axle	2
24	3256-24	Washer - Flat	2

Ref. No.	Part No.	Description	No. Used
25	3296-39	Nut - Lock	2
26	61-9780	Cap - Hub	2
27	3272-12	Pin - Cotter	2
28	28-2480	Washer - Flat	2
29		Front Wheel & Tire Assembly (Incl. Ref. #29:1-29:6)	2
29:1	88-4370	Rim - Wheel	2
29:2	88-4070	Tire	2
29:3	232-27	Stem & Valve	2
29:4	88-4400	Bearing - Wheel	2
29:5	302-5	Fitting - Grease	2
29:6	232-39	Tube - Inner	2
30	92-7889	Spindle - R.H.	1
31	94-1990	Axle - Front	1
32	93-3873	Rod - Tie	1
33	32151-48	Ring - Retaining	2
34	93-3840	Link - Drag	1
35	88-5510	Rod - Parking Brake	1
36	88-5520	Bracket - Parking Brake	1
37	88-0890	Grip - Parking Brake	1
38	3-6498	Washer - Thrust	4

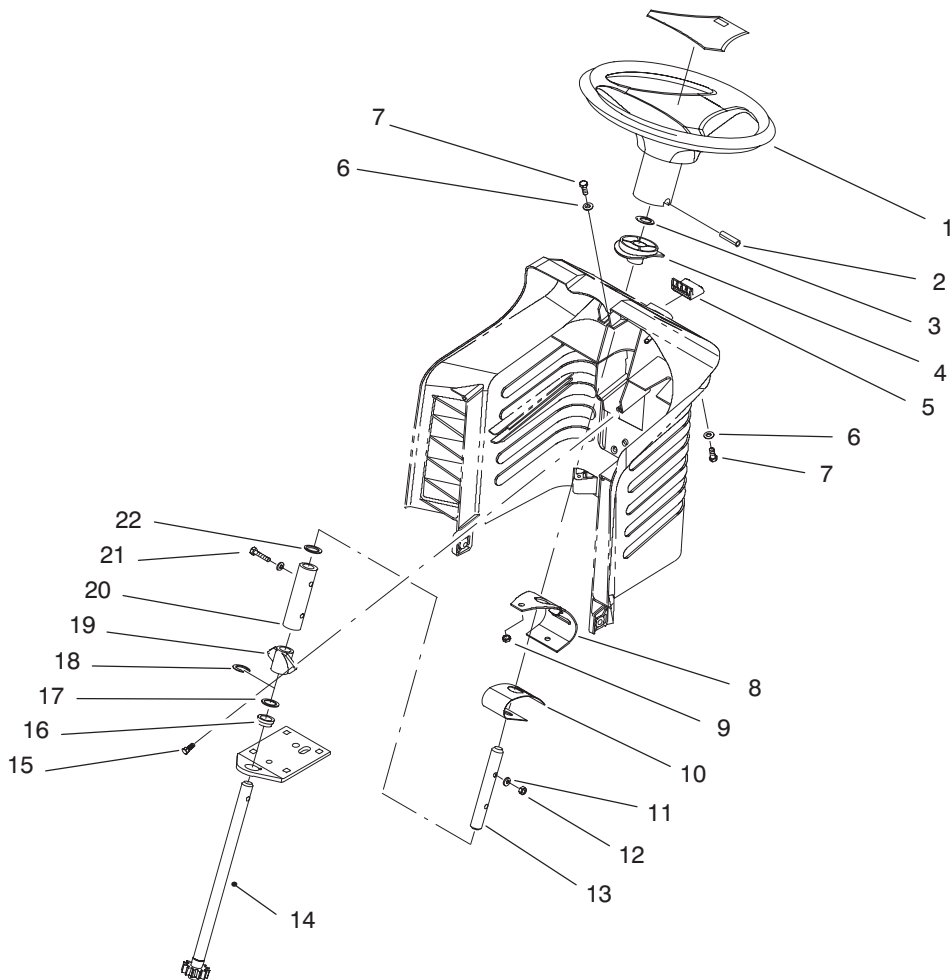

C-2308

STEERING ASSEMBLY

Ref. No.	Part No.	Description	No. Used
1	88-3850	Wheel - Steering (Incl. Ref. #1:2)	1
1:2	88-3870	Cover - Steering Wheel	1
2	32121-111	Pin - Roll	1
3	32151-81	Ring - Retaining	1
4	88-4190	Bushing - Sliding	1
5	88-4180	Button - Release	1
6	3256-22	Washer - Flat	2
7	321-4	Screw - Hex Hd. Cap	2
8	88-5180	Bracket - Backup	1
9	3296-42	Nut - Lock	2
10	88-4890	Spring - Leaf	1

Ref. No.	Part No.	Description	No. Used
11	3-7501	Washer - Curved	4
12	3296-42	Nut - Lock	2
13	88-6300	Shaft - Steering Upper	1
14	88-6370	Shaft - Steering S	1
15	27-0220	Screw - Hex Washer Hd.	2
16	88-5150	Bushing - Flange	1
17	3-6498	Washer - Thrust	1
18	32151-48	Ring - Retaining	1
19	88-4210	Bushing - Stationary	1
20	88-6090	Coupling - Steering	1
21	321-9	Screw - Hex Hd. Cap	2
22	3-6498	Washer - Thrust	1

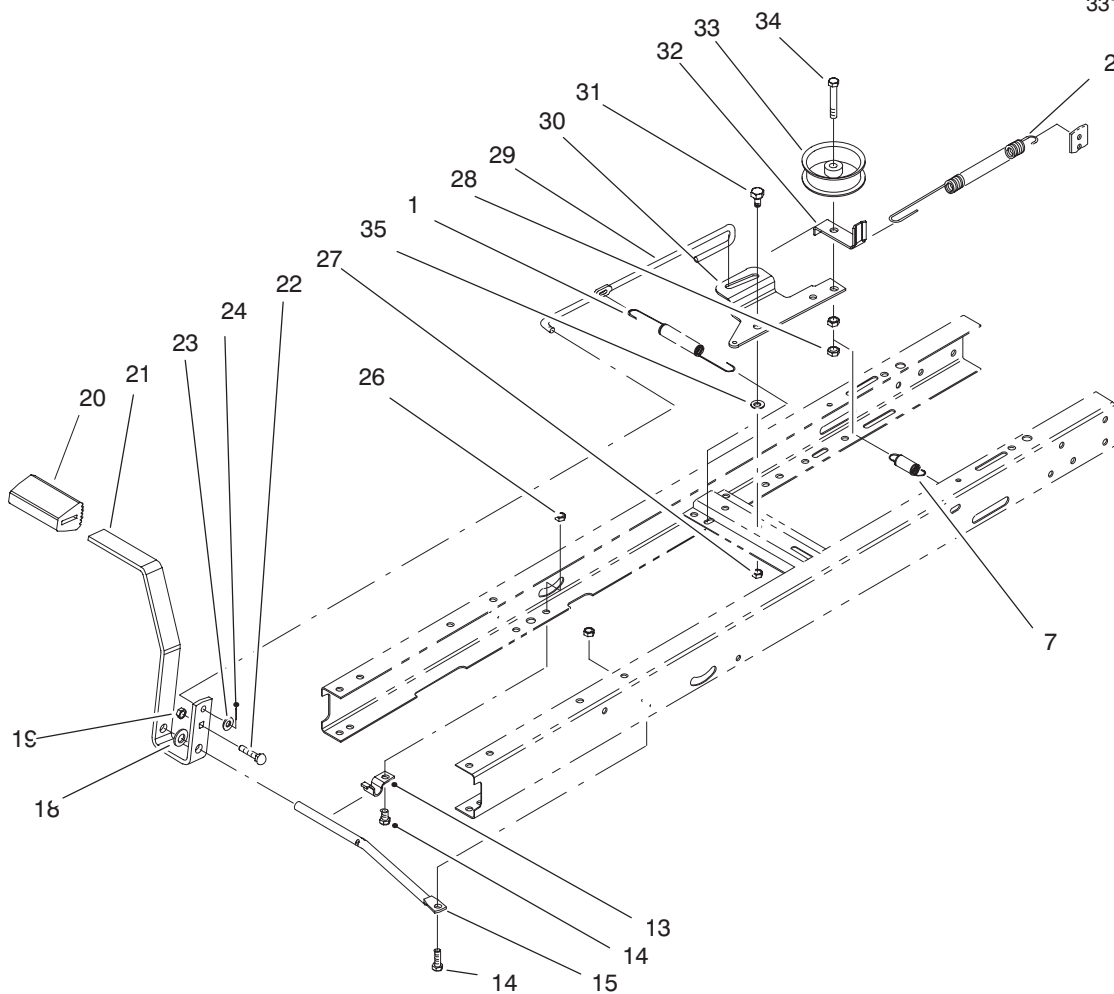

C-2310

CLUTCH ASSEMBLY

Ref. No.	Part No.	Description	No. Used
1	27-8890	Spring - Pedal Return	1
2	88-6140	Spring - Brake	1
7	88-6330	Spring - Extension	1
13	88-4810	Clamp - Shift Pivot	1
14	322-3	Screw - Hex Hd. Cap	2
15	88-5500	Rod - Pedal Pivot	1
18	3256-26	Washer - Flat	1
19	3296-29	Nut - Lock	1
20	65-2920	Pad - Pedal	1
21	88-5000	Pedal - Clutch/Brake	1
22	3230-3	Screw - Carriage	1
23	3256-23	Washer - Flat	1

Ref. No.	Part No.	Description	No. Used
24	3272-10	Pin - Cotter	1
26	3296-29	Nut - Lock	2
27	3296-29	Nut - Lock	1
28	3296-59	Nut - Lock	2
29	88-5270	Rod - Clutch/Brake	1
30	88-6070	Arm - Idler	1
31	37-8770	Bolt - Shoulder	1
32	88-5560	Guide - Belt Idler	1
33	88-5680	Pulley - Flat Idler	1
34	323-11	Screw - Hex Hd. Cap	1
35	5-4460	Washer - Fender	1

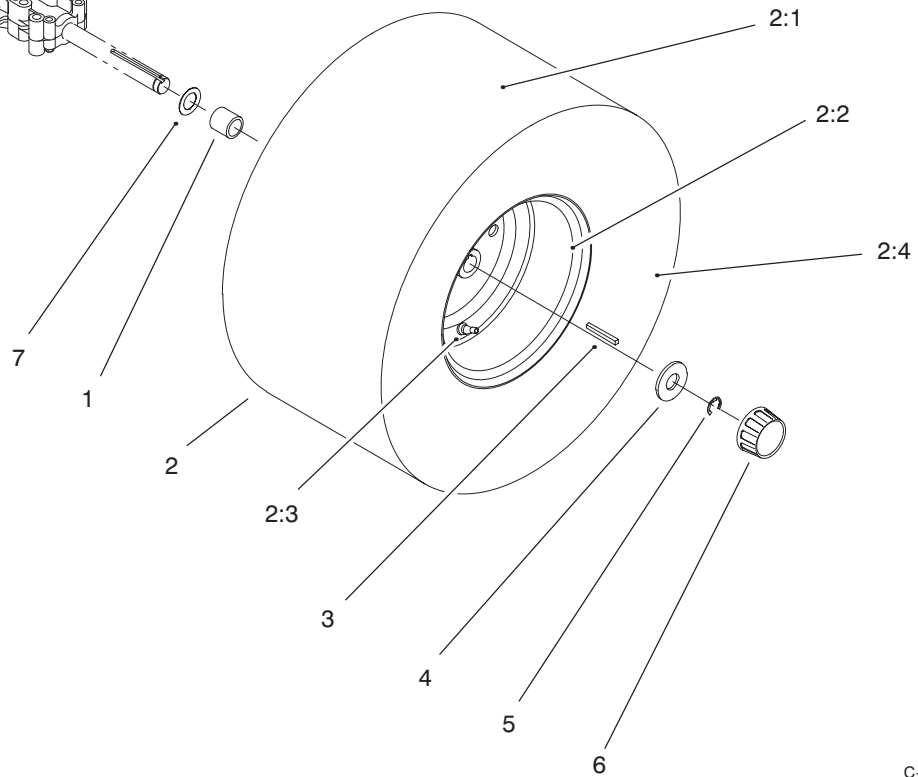

C-2434

REAR AXLE ASSEMBLY

Ref. No.	Part No.	Description	No. Used
1	88-5360	Spacer - Pulley	2
2		Rear Wheel & Tire Asm (Incl. Ref. # 2:1-2:4)	2
2:1	93-0323	Tire	2
2:2	88-4390	Rim Asm	2
2:3	232-27	Valve Stem	2

Ref. No.	Part No.	Description	No. Used
2:4	93-3893	Inner Tube (Optional)	2
3	7-0036	Key - Square	2
4	28-2480	Washer - Flat	2
5	32151-48	Ring - Retaining	2
6	61-9780	Cap - Hub	2
7	3-6498	Washer - Thrust	2

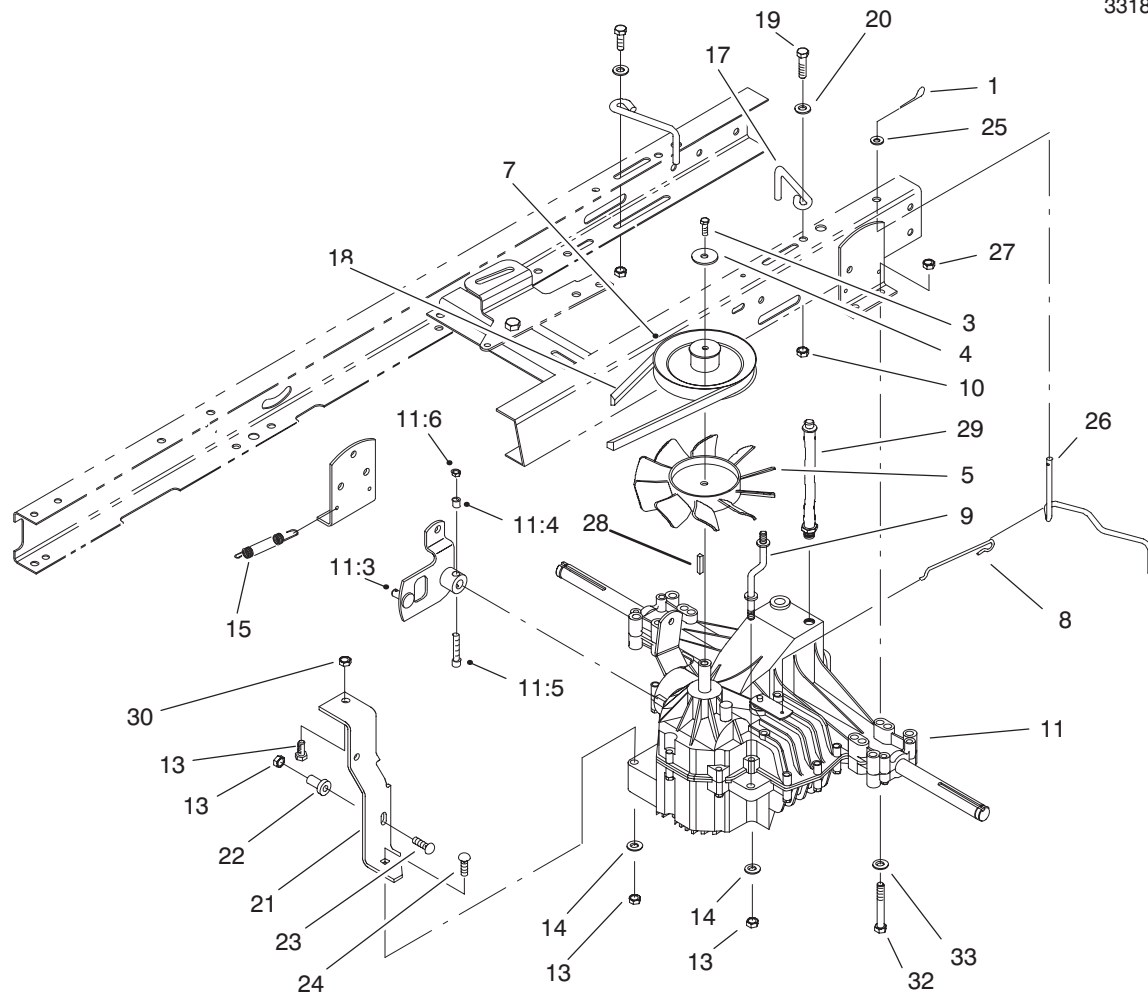

C-2312

TRANSAXLE ASSEMBLY

Ref. No.	Part No.	Description	No. Used
1	3290-307	Pin - Hair Cotter	1
3	48-7620	Screw	1
4	3256-58	Washer - Flat	1
5	93-3867	Fan - Hydro	1
7	93-3862	Pulley - Transmission	1
8	92-8856	Wire - Bypass	1
9	93-3872	Strap - Torque	1
10	3296-29	Nut - Lock	2
11	94-6946	Transaxle Asm - Hydro	1
11:3	93-3870	Lever Asm - Speed Control	1
11:4	86-4270	Spacer - Lock	1
11:5	3274-59	Screw - Hex Socket Hd.	1
11:6	3296-12	Nut - Lock	1
13	3296-29	Nut - Lock	5
14	3256-23	Washer - Flat	3
15	26-6701	Spring - Extension	1

Ref. No.	Part No.	Description	No. Used
16	322-3	Screw - Hex Hd. Cap	1
17	93-3868	Guide - Trans. Belt	2
18	93-3883	V-Belt - Hydro	1
19	322-5	Screw - Hex Hd. Cap	2
20	5-4460	Washer - Fender	2
21	93-3863	Bracket - Speed Control	1
22	65-5080	Bushing - Flanged	1
23	3230-5	Bolt - Carriage	1
24	3230-7	Bolt - Carriage	1
25	3256-22	Washer - Flat	1
26	92-8857	Lever - Bypass	1
27	3296-29	Nut - Lock	4
28	80-6090	Key - Square	1
29	94-1945	Hose - Breather	1
32	322-12	Screw - Hex Hd. Cap	4
33	3256-23	Washer - Flat	4

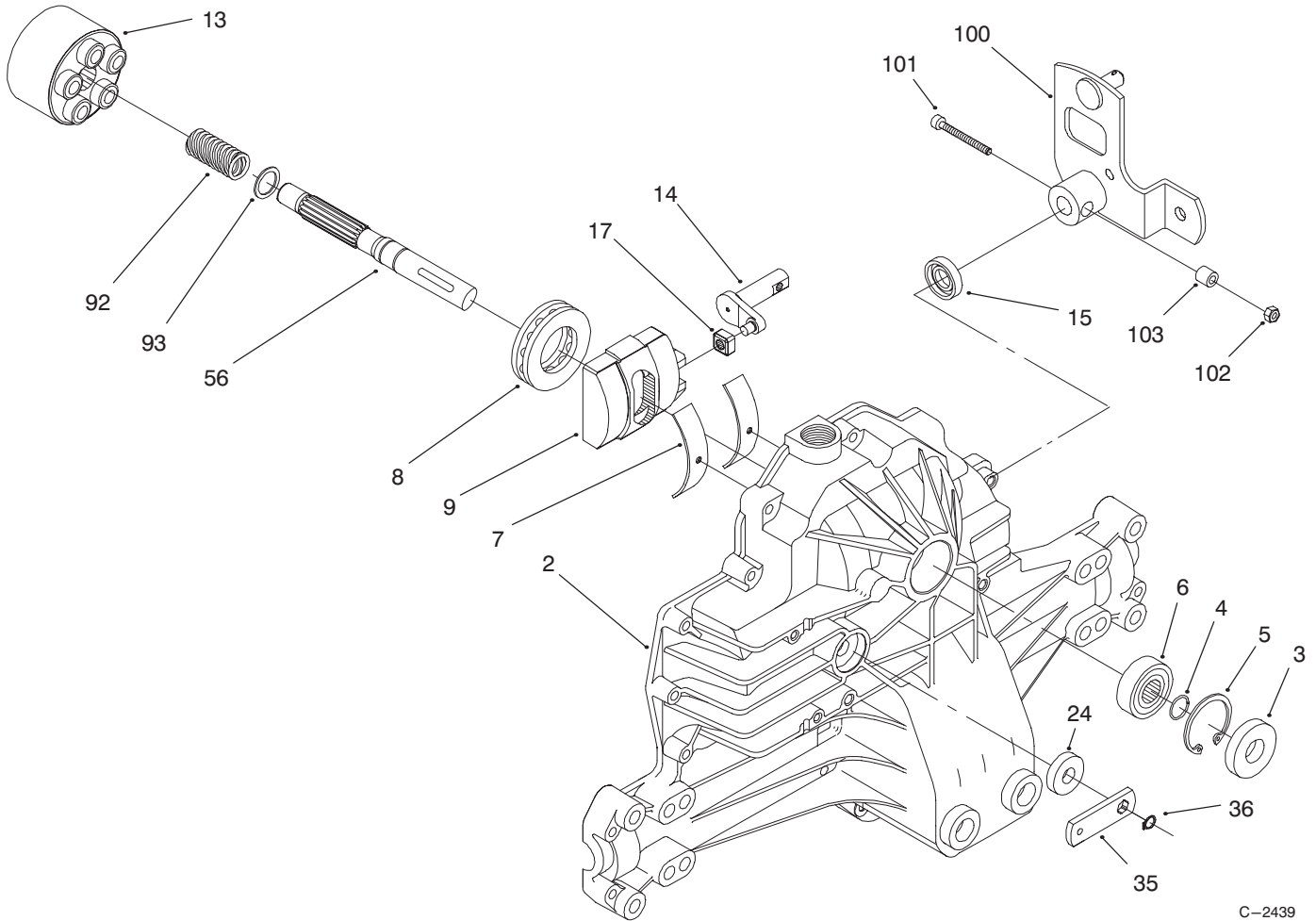

C-2439

HYDRO TRANSAXLE ASSEMBLY

Ref. No.	Part No.	Description	No. Used
2	94-1901	Housing Asm - Upper	1
3	92-6543	Seal - Lip	1
4	94-1902	Ring - Wire Retaining	1
5	94-1903	Ring - Retaining	1
6	94-1904	Bearing - Shaft Ball	1
7	94-1905	Bearing - Cradle	2
8	94-6922	Bearing - Thrust	1
9	94-1907	Swashplate - Variable	1
13	94-1908	Block - Cylinder Asm	1
14	94-1909	Arm - Trunion	1
15	92-6544	Seal - Lip	1

Ref. No.	Part No.	Description	No. Used
17	94-1910	Guide - Slot	1
24	92-6545	Seal - Lip	1
35	92-6547	Arm - Bypass	1
36	936109	Ring - Retaining	1
56	94-1925	Shaft - Input	1
92	94-1936	Spring - Block	1
93	94-1937	Washer - Block Thrust	1
100	93-3870	Control Arm	1
101	3274-59	Screw - Cap Socket Hd.	1
102	3296-12	Nut	1
103	86-4270	Spacer	1

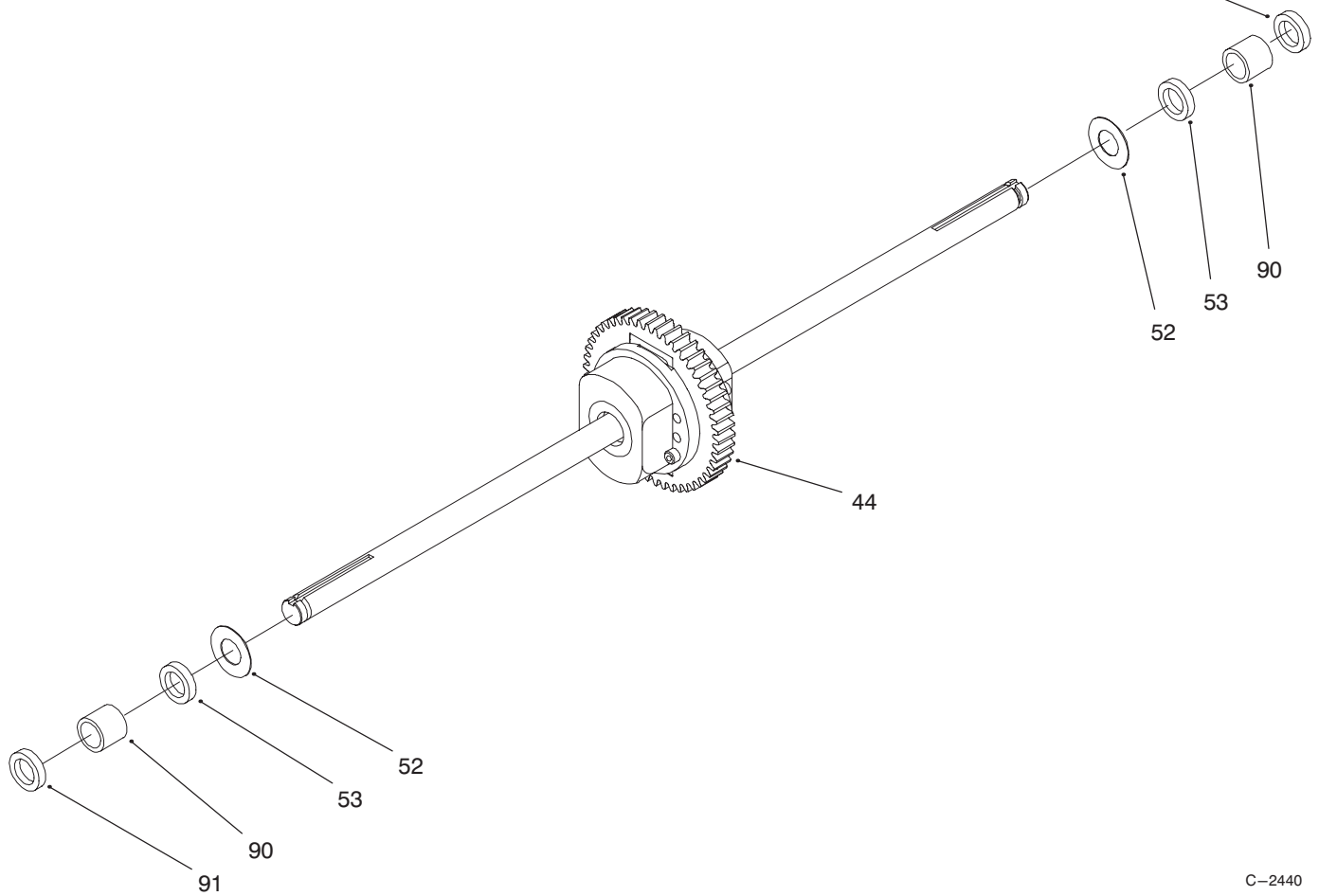

C-2440

HYDRO TRANSAXLE ASSEMBLY (Continued)

Ref. No.	Part No.	Description	No. Used
44	94-1921	Differential Asm	1
52	94-1922	Washer	2
53	94-1924	Seal	2

Ref. No.	Part No.	Description	No. Used
90	94-1934	Sleeve - Bearing	2
91	94-1935	Seal - Wiper	2

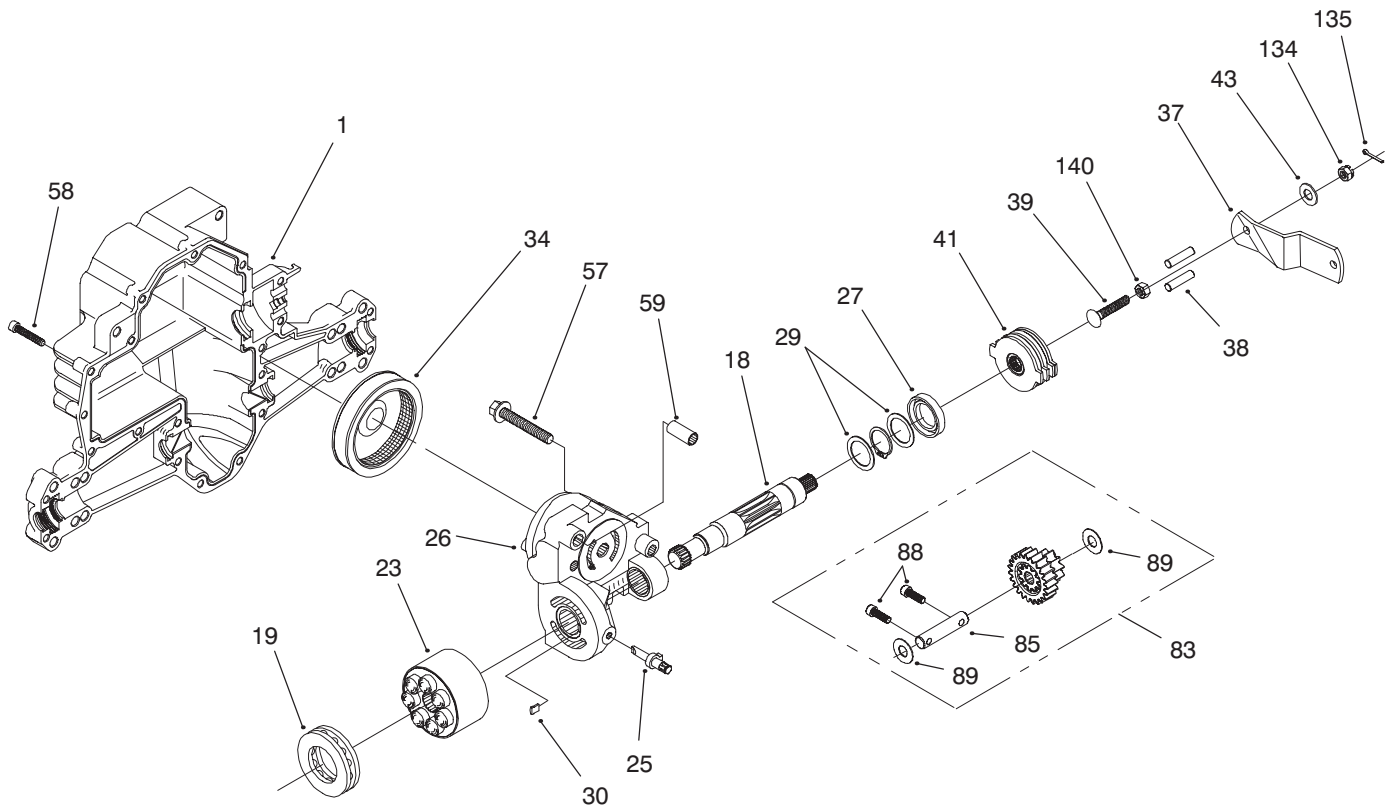

C-2441A

HYDRO TRANSAXLE ASSEMBLY (Continued)

Ref. No.	Part No.	Description	No. Used
1	94-1900	Housing – Lower	1
18	94-6955	Shaft – Motor	1
19	94-6923	Bearing – Thrust	1
23	94-1913	Block – Cylinder Asm	1
25	94-1914	Actuator – Bypass	1
26	94-1915	Centersection Asm	1
27	94-1916	Seal – Lip	1
28	94-1917	Ring – Retaining	1
29	94-1918	Washer	2
30	94-6925	Bypass Plate	1
34	94-1920	Oil Filter Element	1
37	93-3861	Lever – Brake	1
38	92-6549	Pin – Actuating	1

Ref. No.	Part No.	Description	No. Used
39	94-1923	Bolt	1
41	94-1919	Brake Rotor/Starter Kit	4
43	5-4460	Washer – Fender	1
57	94-6926	Bolt	3
58	94-1926	Bolt	21
59	94-1927	Pin	2
83	94-1930	Jackshaft/Pinion Gear Asm	1
85	94-6956	Jackshaft	1
88	94-1932	Capscrew	2
89	94-1933	Washer	2
134	93-3807	Nut – Castle	1
135	3272-7	Pin – Cotter	1
140	3296-20	Nut – Lock Insert	1

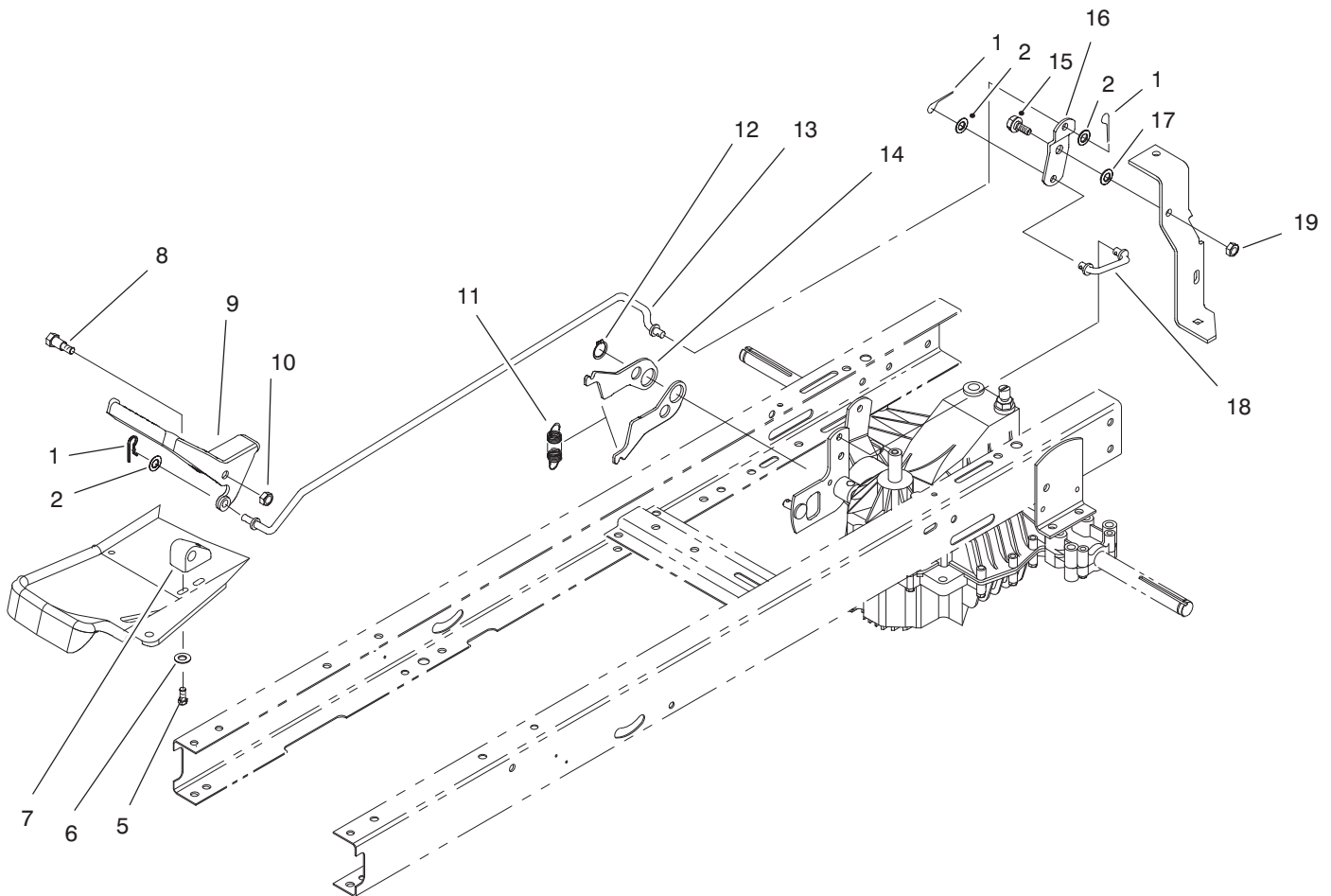

C-2313

SPEED CONTROL ASSEMBLY

Ref. No.	Part No.	Description	No. Used	Ref. No.	Part No.	Description	No. Used
1	3290-307	Pin - Hair Cotter	4	12	32151-83	Ring - Retaining	1
2	3256-23	Washer - Flat	4	13	93-3877	Rod - Speed Control	1
5	46-8090	Screw - Tapping	2	14	88-5610	Lever - Neutral Return	2
6	3256-22	Washer - Flat	2	15	37-8771	Bolt - Shoulder	1
7	88-4690	Block - Pivot	1	16	93-3875	Bellcrank	1
8	23-0310	Bolt - Shoulder	1	17	3290-456	Washer - Belleville	1
9	93-3812	Pedal - Speed Control	1	18	93-3874	Link - Speed/Direct Control	1
10	3296-59	Nut - Lock	1	19	3296-47	Nut - Lock	1
11	92-7305	Spring - Extension	1				

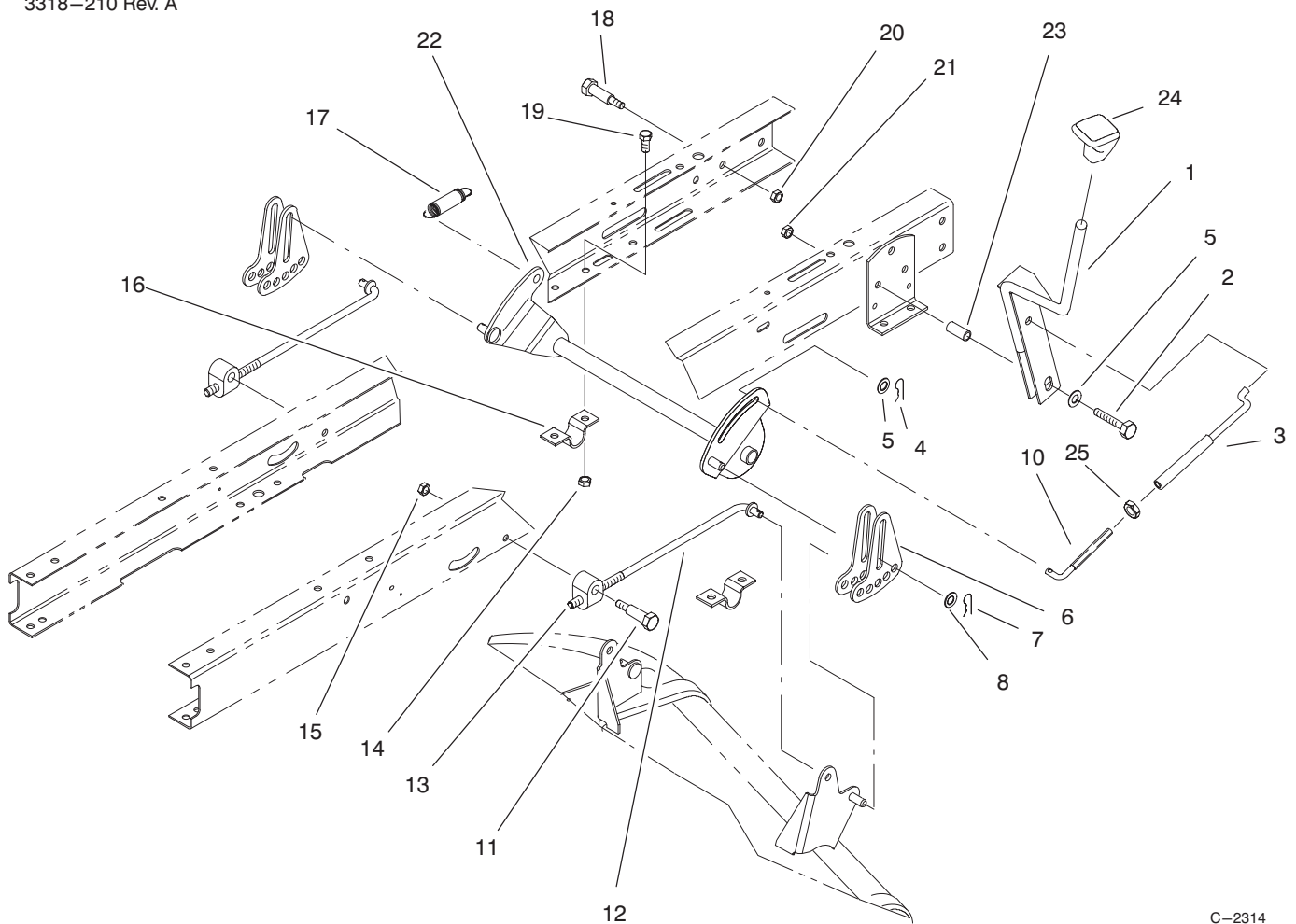

C-2314

HEIGHT OF CUT ASSEMBLY

Ref. No.	Part No.	Description	No. Used
1	93-3822	Lever - H.O.C.	1
2	322-9	Screw - Hex Hd. Cap	1
3	93-3885	Tube	1
4	3290-307	Pin - Hair Cotter	1
5	3256-24	Washer - Flat	2
6	88-5570	Link - Adjusting H.O.C.	4
7	3290-307	Pin - Hair Cotter	2
8	80-6990	Washer - Hardened	2
10	93-3888	Link - H.O.C.	1
11	7-0030	Bolt - Shoulder	2
12	88-5450	Rod - Hanger Rear	2
13	88-4230	Trunnion - H.O.C. Rear	2

Ref. No.	Part No.	Description	No. Used
14	3296-29	Nut - Lock	4
15	3296-29	Nut - Lock	2
16	88-4730	Clamp - H.O.C. Pivot	2
17	93-3808	Spring - Extension	1
18	7-0030	Bolt - Shoulder	1
19	322-3	Screw - Hex Hd. Cap	4
20	3296-29	Nut - Lock	1
21	3296-29	Nut - Lock	1
22	93-7660	Pivot - H.O.C.	1
23	65-7210	Spacer	1
24	94-5565	Knob - Control	1
25	3218-2	Nut - Hex Jam	1

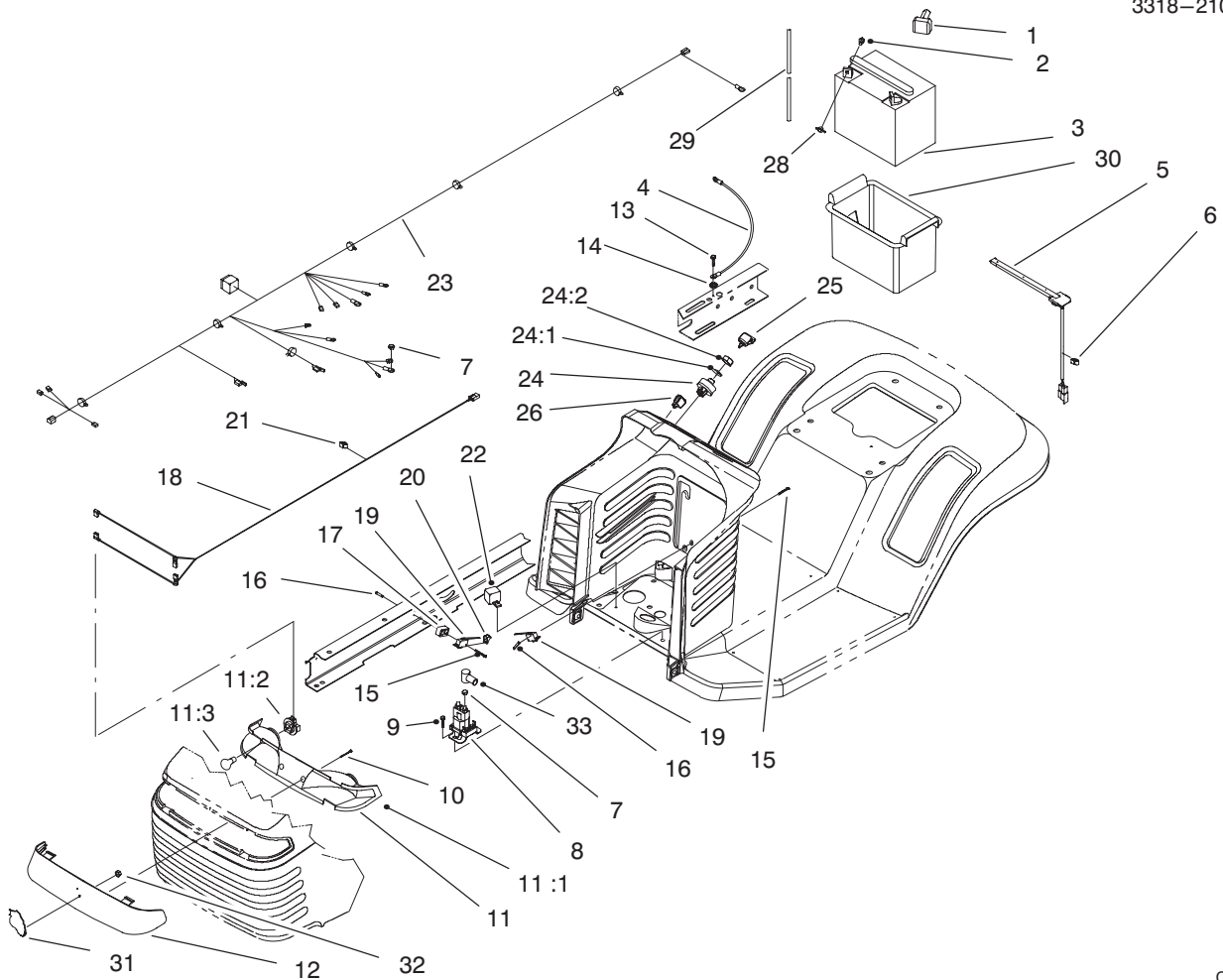

C-2435

ELECTRICAL ASSEMBLY

Ref. No.	Part No.	Description	No. Used	Ref. No.	Part No.	Description	No. Used
1	28-8080	Boot - Battery Terminal	1	16	3290-354	Nut - Speed	2
2	321-4	Screw - Hex Hd. Cap	2	17	88-4880	Spacer - Microswitch	1
3	80-2600	Battery - 7 Plate	1	18	88-4320	Harness - Wire/Lights	1
4	44-8110	Cable - Battery Negative	1	19	88-9932	Switch - Micro	2
5	38-1420	Switch - Seat	1	20	93-3240	Seal - Plunger	1
6	702366	Clip - Wire Retainer	1	21	702366	Clip - Wire Retainer	2
7	32149-2	Nut - Lock Keps	3	22	116397	Relay - S.P.D.T.	1
8	92-9845	Solenoid	1	23	93-3810	Harness - Wire	1
9	32144-4	Screw - Tapping	2	24	88-9830	Switch - Ignition	1
10	32144-32	Screw - Plastic	2	24:1	3254-5	Washer - Lock	1
11	88-3970	Reflector - Lamp Asm (Incl. Ref. #11:1-11:3)	1	24:2	218-461	Nut - Hex	1
11:1	93-8741	Reflector - Headlight	1	25	63-8360	Key - Ignition	1
11:2	111686	Socket Assembly	2	26	92-8875	Switch - Rocker Lights	1
11:3	7228	Bulb - Light	2	28	32103-22	Nut - Wing Nylon	2
12	88-3960	Lens - Headlights	1	29	56-2540	Tube - Vent	1
13	32144-4	Screw - Tapping	1	30	88-4040	Box - Battery	1
14	3255-7	Washer - Lock	1	31	80-2240	Plate - Name Grille	1
15	93-0539	Screw - Phillips Pan Hd.	4	32	3290-299	Nut - Tinnerman	1
				33	94-5362	Boot - Terminal Insulator	1

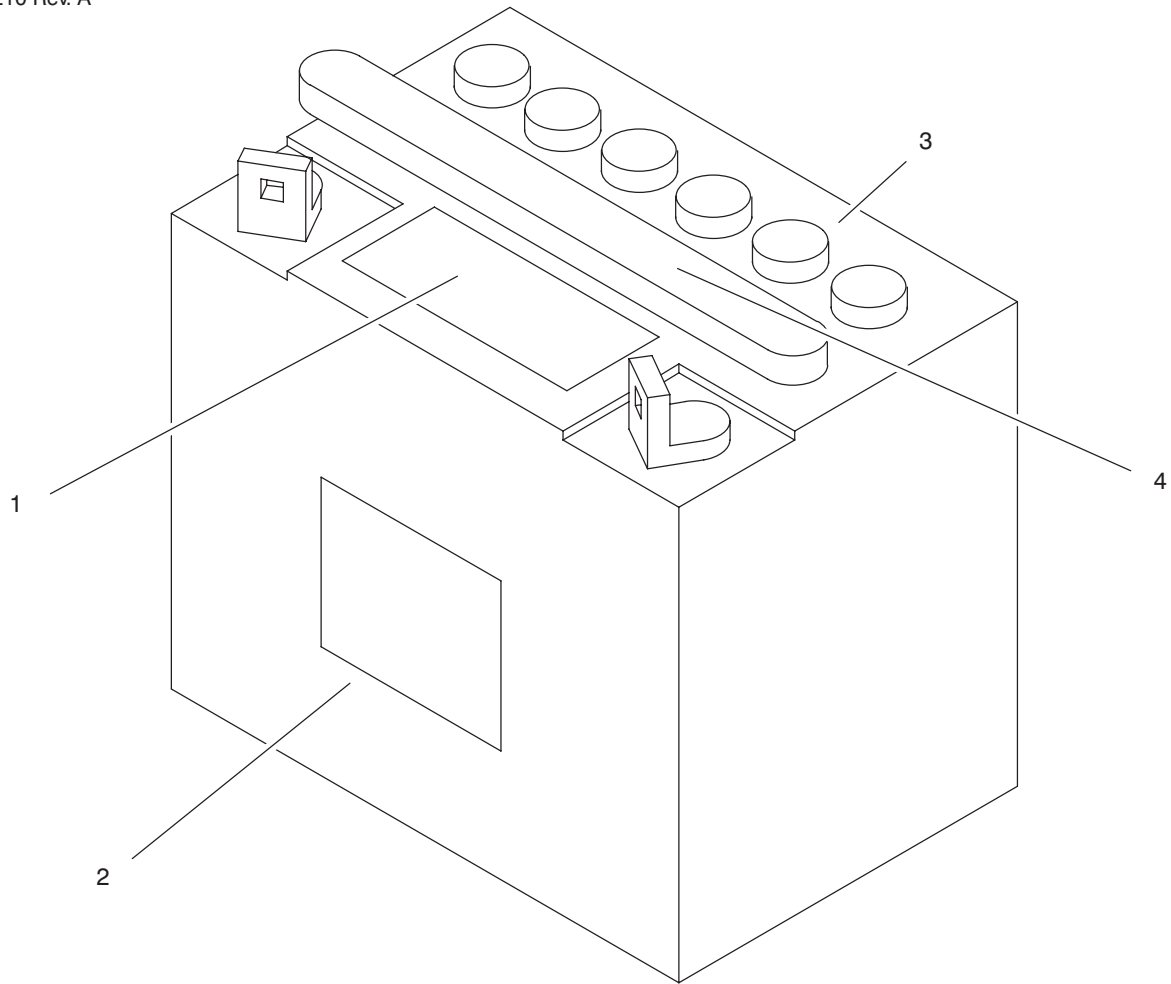

C-2436

BATTERY ASSEMBLY

Ref. No.	Part No.	Description	No. Used
1	93-7276	Decal - Danger	1
2	93-6668	Decal - Battery Charge Inst.	1

Ref. No.	Part No.	Description	No. Used
3	218-560	Cap - Battery	6
4	93-9354	Decal - Battery	1

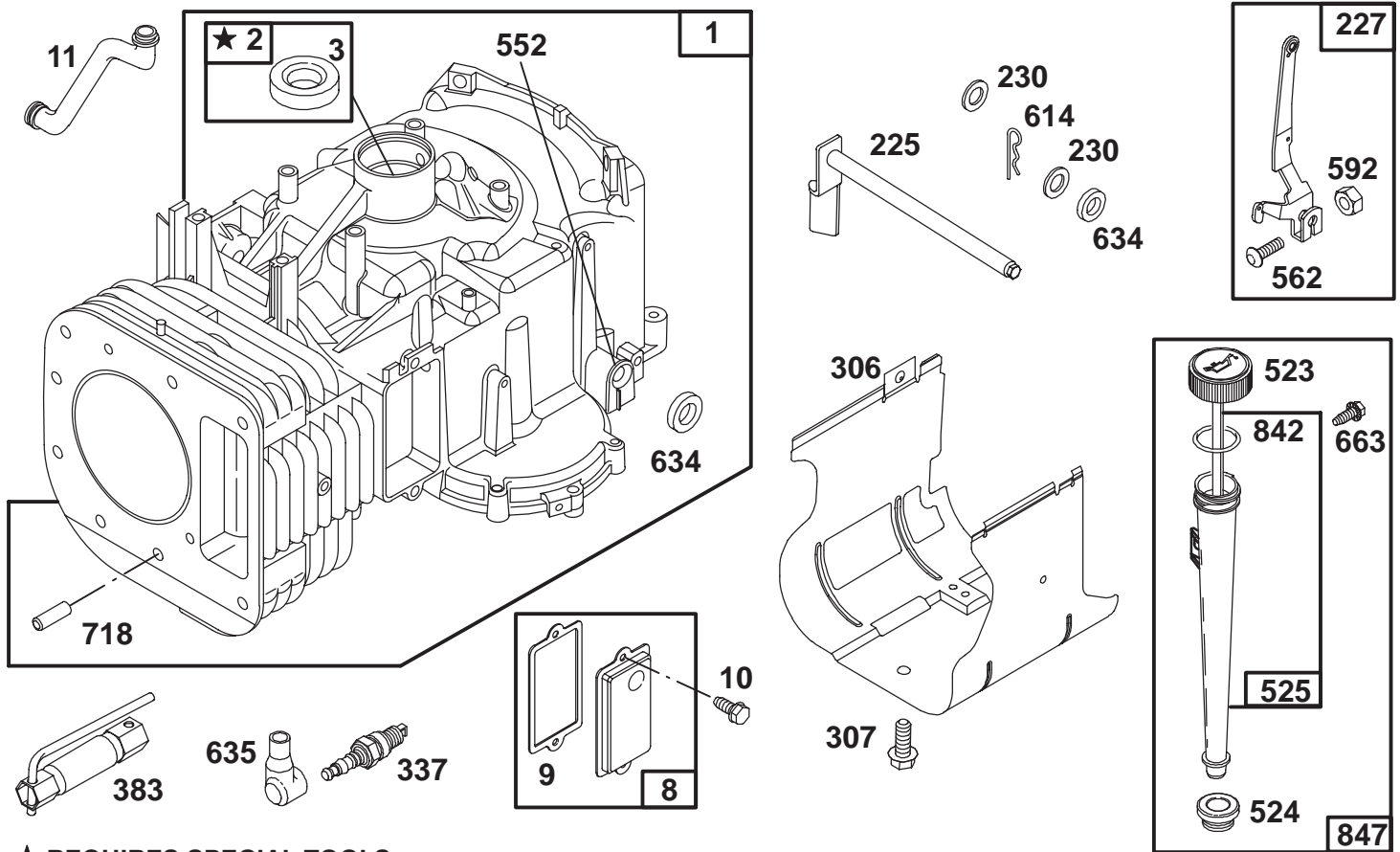

★ REQUIRES SPECIAL TOOLS TO INSTALL. SEE REPAIR INSTRUCTION MANUAL.

Assemblies include all parts shown in frames.

ENGINE BRIGGS & STRATTON MODEL 28Q777-0668-A1

Ref. No.	Part No.	Description	No. Used
1	496412	Cylinder Assembly	1
2	399265	Bearing—Cylinder	1
★3	391086	Seal—Oil	1
8	495735	Breather Assembly	1
★9	27803	Gasket—Valve Cover	1
10	94621	Screw—Sem	1
11	281246	Tube—Breather	1
225	495157	Crank—Governor	1
227	493935	Lever Assy.—Governor	1
230	94742	Washer—Governor Lever	1
306	225020	Shield—Cylinder	1
307	94623	Screw—Self Tap	1
332A	94314	Nut—Hex.	1
337	491055	Plug—Spark	1
383	89838	Wrench—Spark Plug	1

Ref. No.	Part No.	Description	No. Used
523	495230	Cap—Oil Fill	1
★524	66838	Seal—Fill Tube	1
525	496113	Tube—Oil Fill	1
552	231597	Bushing—Gov. Crank	1
562	92613	Bolt—Governor Lever	1
592	231082	Nut—Hex.	1
614	93306	Pin—Cotter	1
★634	491323	Seal—Governor	1
635	280872	Elbow—Spark Plug	1
663	94073	Screw—Hex. Head	1
718	230192	Pin—Dowel	1
★842	270920	Seal—Oil Fill Cap	1
847	496415	Fill Group—Oil	1

★ Included in Gasket Set—Part No. 495993.

△ Included in Valve Overhaul Kit—Part No. 495992.

● Included in Carburetor Kit—Part No. 498116.

◆ Included in Carburetor Gasket Set—Part No. 494385.

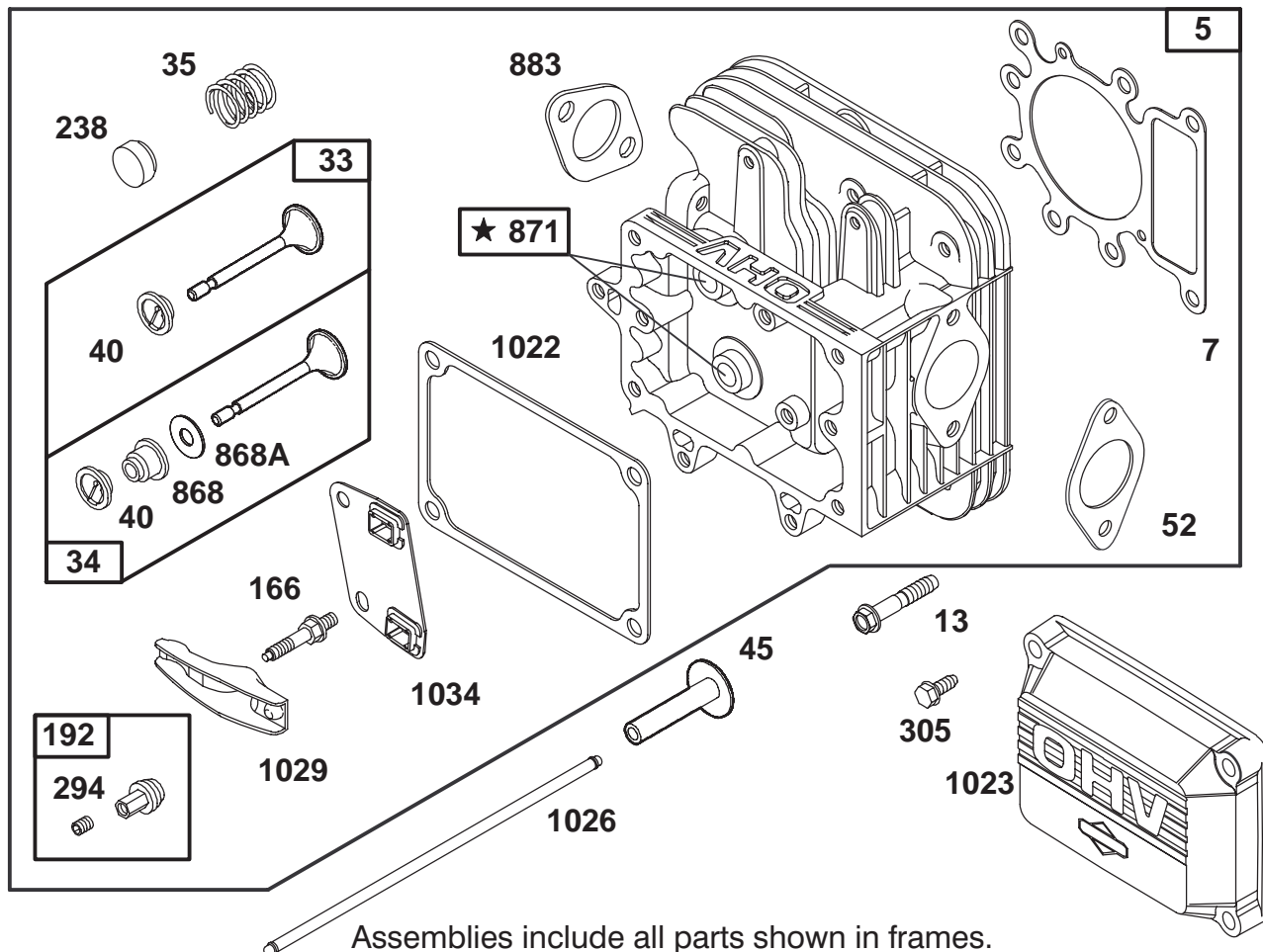

ENGINE BRIGGS & STRATTON MODEL 28Q777-0668-A1

Ref. No.	Part No.	Description	No. Used
5	495858	Head-Cylinder	1
Δ★7	272614	Gasket-Cylinder Head	1
13	94728	Screw-Cylinder Head	1
33	495856	Valve-Exhaust	1
34	495857	Valve-Intake	1
35	262811	Spring-Valve	1
40	224641	Retainer-Valve	1
45	262411	Tappet-Valve	1
Δ★52	272569	Gasket-Carb. Mounting	1
166	94555	Stud-Rocker Arm	1
192	492160	Screw Assy. Rocker Arm	1
238	262836	Cap-Valve	1
294	810068	Screw-Set	1

Ref. No.	Part No.	Description	No. Used
305	94682	Screw-Hex. Head	1
Δ★868	494435	Seal-Valve	1
Δ★868A	272610	Seal-Valve	1
871	262835	Bushing-Guide (Intake and Exhaust)	1
Δ★883	272293	Gasket-Exhaust	1
Δ★1022	272475	Gasket-Rocker Cover	1
1023	214314	Cover-Rocker	1
1026	494432	Rod-Push (Intake)	1
		Note: 495136 Rod-Push (Exhaust)	1
1029	224554	Arm-Rocker	1
1034	494432	Guide-Push Rod	1

★ Included in Gasket Set-Part No. 495993.

Δ Included in Valve Overhaul Kit-Part No. 495992.

● Included in Carburetor Kit-Part No. 498116.

◆ Included in Carburetor Gasket Set-Part No. 494385.

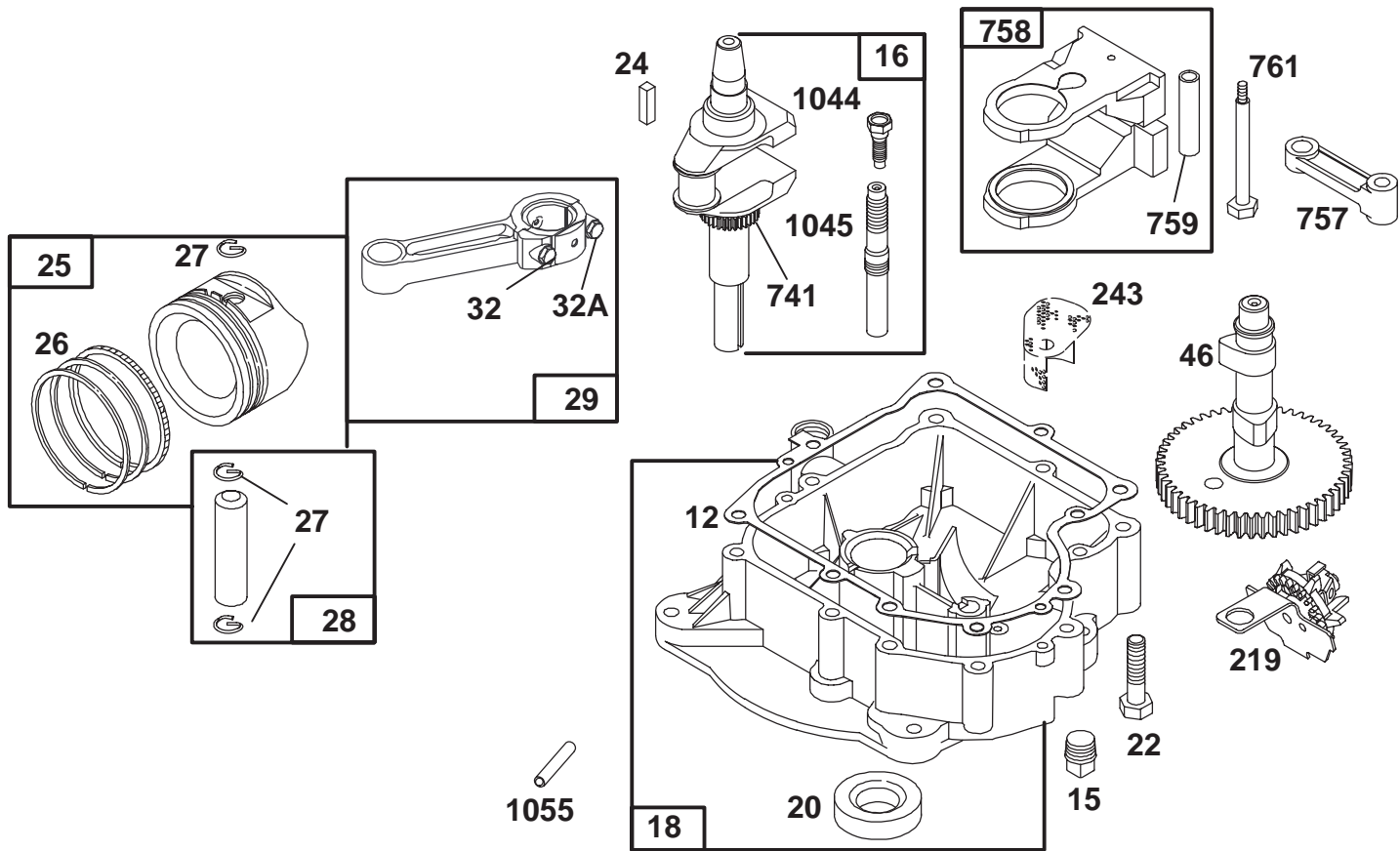

Assemblies include all parts shown in frames.

ENGINE BRIGGS & STRATTON MODEL 28Q777-0668-A1

Ref. No.	Part No.	Description	No. Used
★12	271916	Gasket-Crankcase (.015" Thick)	1
★	271997	Gasket-Crankcase (.005" Thick)	1
★	271996	Gasket-Crankcase (.009" Thick)	1
15	94239	Plug-Oil Drain	1
16	495162	Crankshaft	1
		Note: For Timing Gear Key-Order 94196.	1
18	496742	Base-Engine	1
★20	291675	Seal-Oil	1
22	94624	Screw-Sem	1
24	222698	Key-Flywheel	1
25	494860	Piston Assembly (Standard)	1
	495977	Piston Assy. (.010" O.S.)	1
	495978	Piston Assy. (.020" O.S.)	1
	495979	Piston Assy. (.030" O.S.)	1
26	495854	Ring Set (Standard)	1
	495852	Ring Set (.010" O.S.)	1
	495851	Ring Set (.020" O.S.)	1
	495855	Ring Set (.030" O.S.)	1

Ref. No.	Part No.	Description	No. Used
27	260924	Lock-Piston Pin	1
28	299691	Pin-Piston (Standard)	1
	391286	Pin-Piston (.005" O.S.)	1
29	494504	Rod-Connecting	1
	495490	Rod-Conn. (.020" U.S.)	1
32	94695	Screw-Conn. Rod (1 57/64" Long)	1
32A	94648	Screw-Conn. Rod (1 5/8" Long)	1
46	496885	Gear-Cam	1
219	490815	Gear-Gov.	1
243	225076	Screen-Oil	1
741	262932	Gear-Timing	1
757	213998	Link-Counterweight	1
758	399891	Counterweight Assy.	1
759	298909	Pin-Counterweight	1
761	94593	Screw-Counterweight	1
1044	94673	Screw-Shoulder	1
1045	231828	Extension-Crankshaft	1
1055	231931	Tube-Oil Pump	1

★ Included in Gasket Set-Part No. 495993.

△ Included in Valve Overhaul Kit-Part No. 495992.

● Included in Carburetor Kit-Part No. 498116.

◆ Included in Carburetor Gasket Set-Part No. 494385.

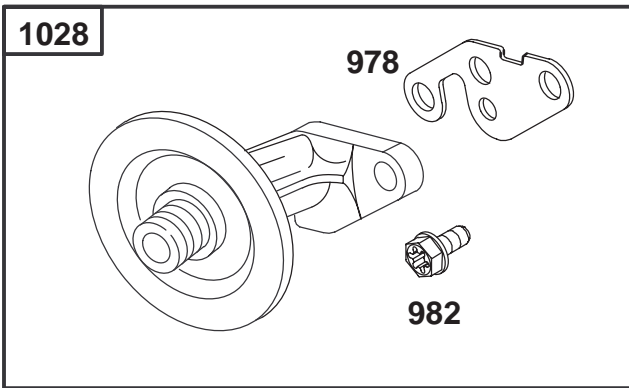
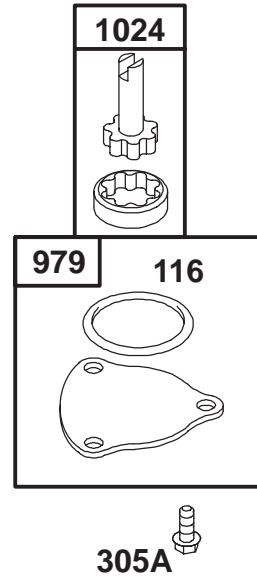
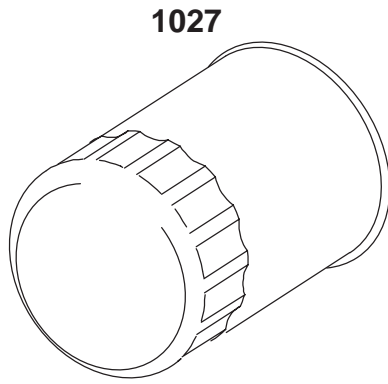

Assemblies include all parts shown in frames.

ENGINE BRIGGS & STRATTON MODEL 28Q777-0668-A1

Ref. No.	Part No.	Description	No. Used
★116	281402	O-Ring	1
305A	94786	Screw-Sem	1
★978	272888	Gasket-Adapter	1
979	496745	Cover-Pump	1

Ref. No.	Part No.	Description	No. Used
982	94899	Screw-Sem	1
1024	493884	Pump-Oil	1
1027	492932	Filter-Oil	1
1028	496744	Adapter-Filter	1

★ Included in Gasket Set-Part No. 495993.

△ Included in Valve Overhaul Kit-Part No. 495992.

● Included in Carburetor Kit-Part No. 498116.

◆ Included in Carburetor Gasket Set-Part No. 494385.

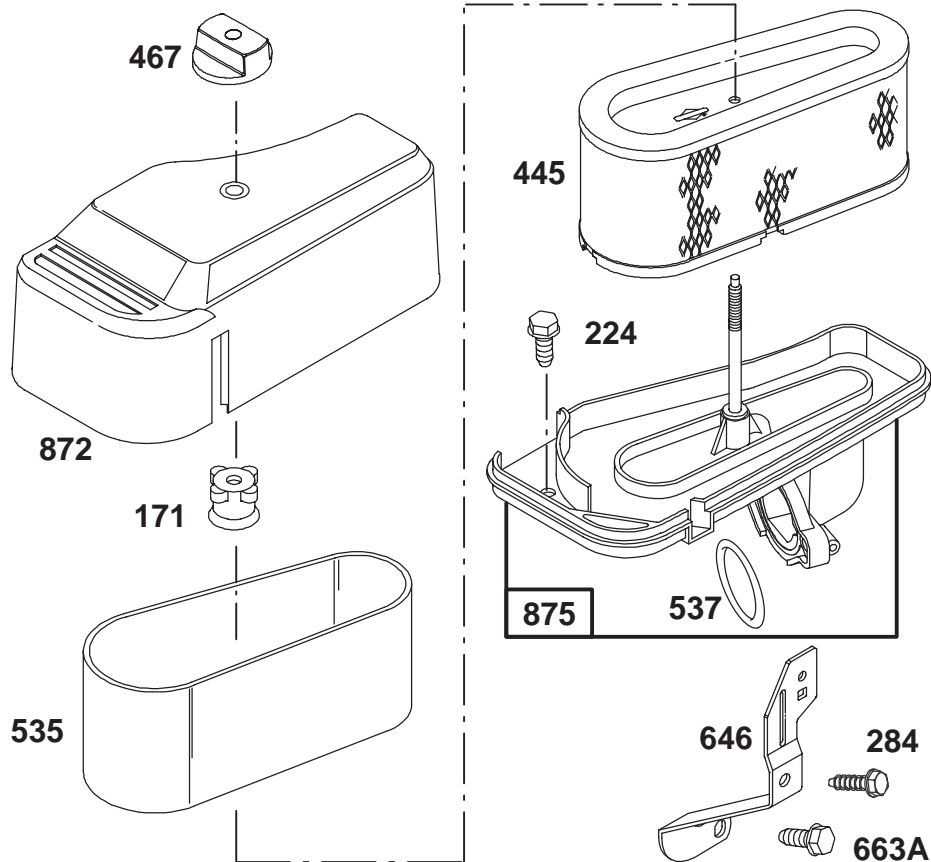

Assemblies include all parts shown in frames.

ENGINE BRIGGS & STRATTON MODEL 28Q777-0668-A1

Ref. No.	Part No.	Description	No. Used
171	281051	Nut—Air Cleaner Mtg.	1
224	94729	Screw—Air Cleaner Sem	1
284	94704	Screw—Air Cleaner	1
445	493909	Filter—Air	1
467	493903	Knob—Air Cleaner	1
535	272403	Filter—Air	1

Ref. No.	Part No.	Description	No. Used
★537	281106	Gasket—Air Cleaner	1
646	224546	Brace—Air Cleaner	1
663A	94620	Screw—Hex. Hd.	1
872	281365	Cover—Air Cleaner	1
875	495862	Body—Air Cleaner	1

★ Included in Gasket Set—Part No. 495993.
 △ Included in Valve Overhaul Kit—Part No. 495992.

● Included in Carburetor Kit—Part No. 498116.
 ◆ Included in Carburetor Gasket Set—Part No. 494385.

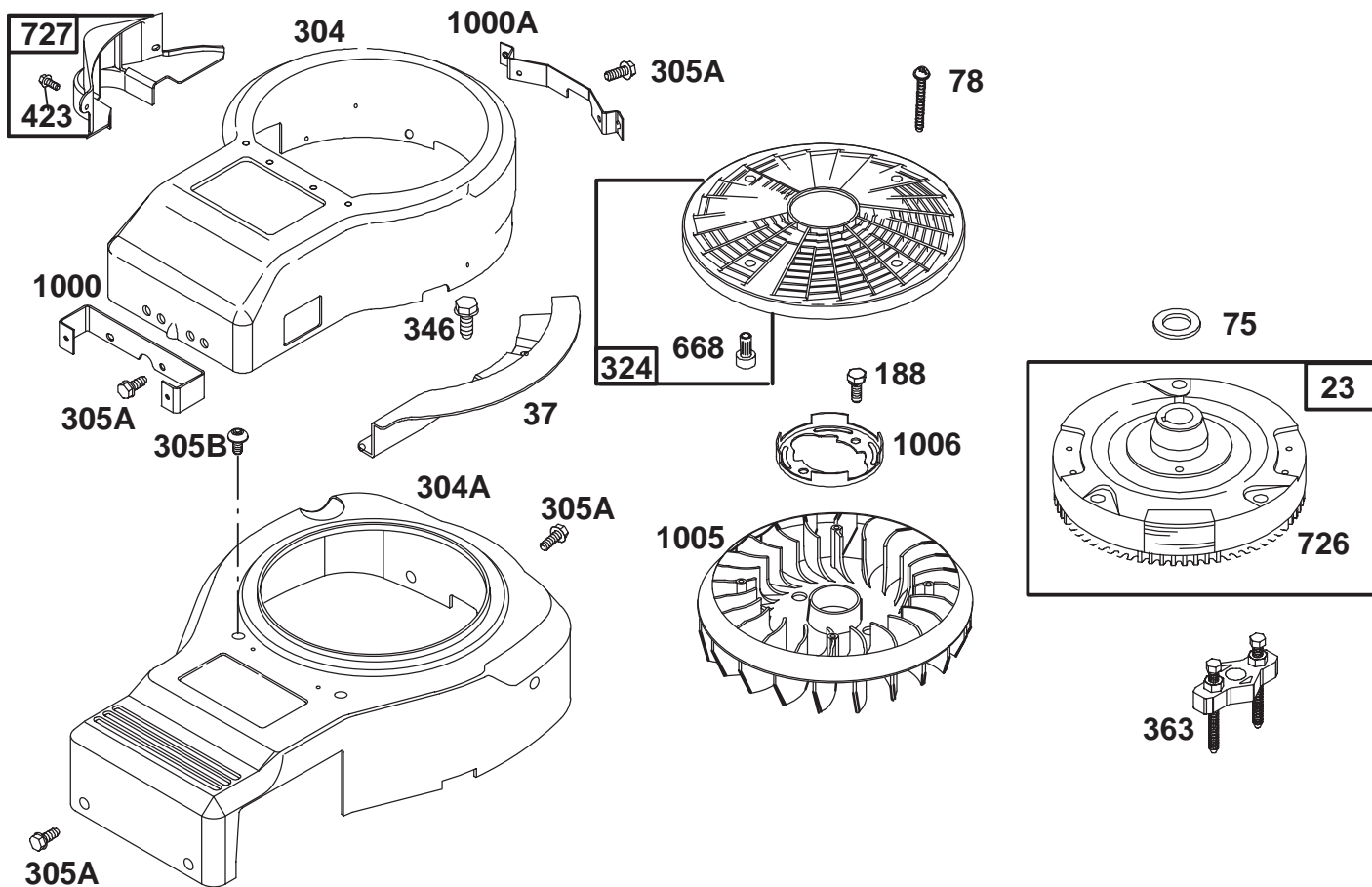

Assemblies include all parts shown in frames.

ENGINE BRIGGS & STRATTON MODEL 28Q777-0668-A1

Ref. No.	Part No.	Description	No. Used
23	492326	Flywheel	1
37	224502	Guard-Flywheel	1
75	225136	Washer-Flat	1
78	94821	Screw-Sem	1
188	94627	Screw-Sem	1
304	225175	Housing-Blower (Inner)	1
304A	225017	Housing-Blower (Outer)	1
305A	94786	Screw-Hex. Head	1
305B	94822	Screw-Sem	1
324	494439	Screen-Rotating	1
346	93705	Screw-Hex. Head	1

Ref. No.	Part No.	Description	No. Used
363	19203	Puller-Flywheel	1
423	94073	Screw-Sem	1
668	805402	Spacer	1
726	392134	Gear-Ring (Includes Mtg. Hardware)	1
727	490324	Housing-Drive	1
1000	224968	Bracket-Front	1
1000A	224969	Bracket-Rear	1
1005	281400	Fan-Flywheel	1
1006	224413	Retainer-Fan	1

★ Included in Gasket Set-Part No. 495993.

△ Included in Valve Overhaul Kit-Part No. 495992.

● Included in Carburetor Kit-Part No. 498116.

◆ Included in Carburetor Gasket Set-Part No. 494385.

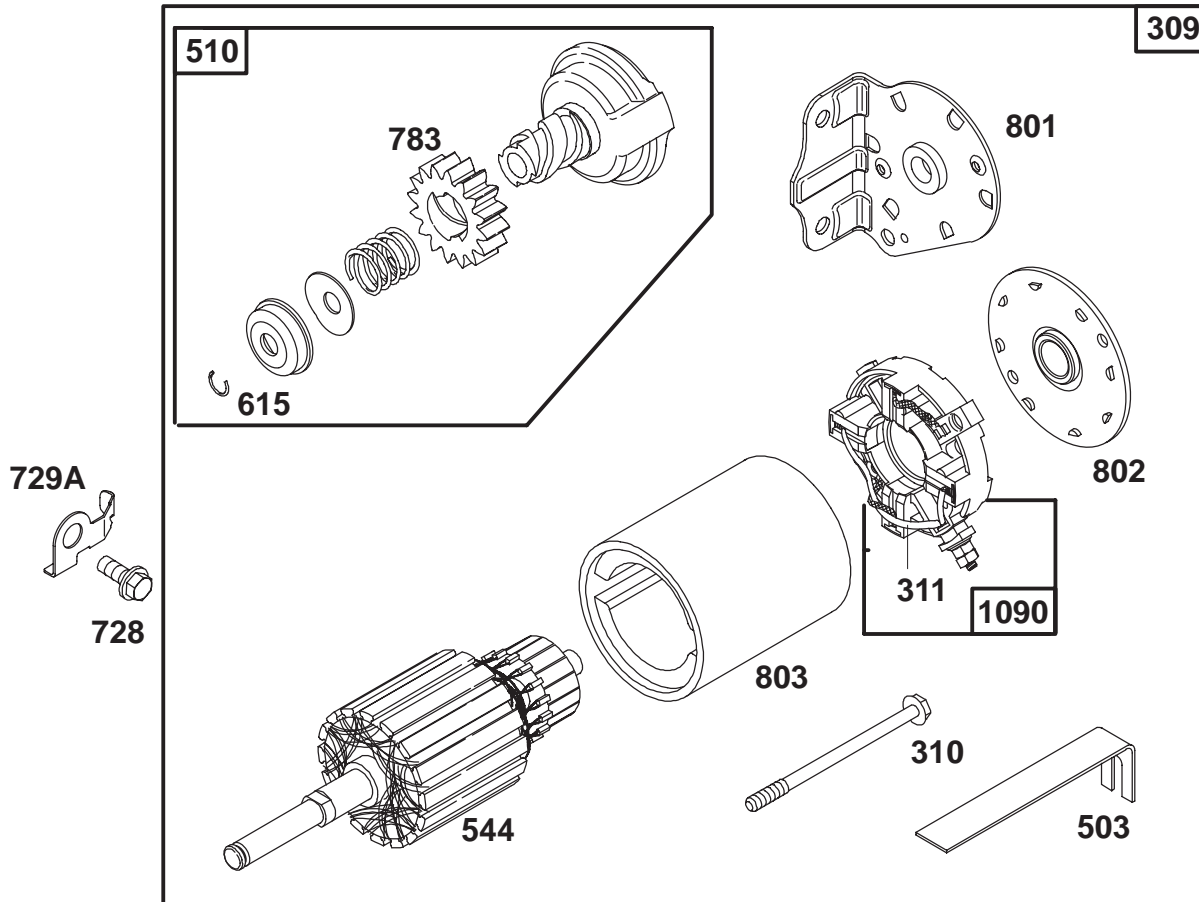

Assemblies include all parts shown in frames.

ENGINE BRIGGS & STRATTON MODEL 28Q777-0668-A1

Ref. No.	Part No.	Description	No. Used
309	497595	Motor-Starter	1
310	94003	Bolt-Thru	1
311	497608	Brush Set	1
503	806000	Strap-Starter	1
510	497606	Drive-Starter	1
544	497603	Armature-Starter	1
615	263080	Retainer	1

Ref. No.	Part No.	Description	No. Used
728	94627	Screw-Hex. Head	1
729A	225170	Clip-Wire	1
783	280104	Gear-Starter	1
801	394856	Cap-Drive	1
802	497607	Plate-Cover	1
803	497604	Housing-Starter	1
1090	497605	Cap-End	1

★ Included in Gasket Set-Part No. 495993.

△ Included in Valve Overhaul Kit-Part No. 495992.

● Included in Carburetor Kit-Part No. 498116.

◆ Included in Carburetor Gasket Set-Part No. 494385.

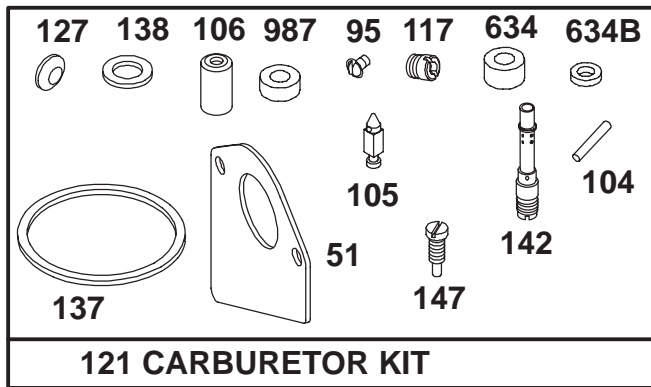

121 CARBURETOR KIT

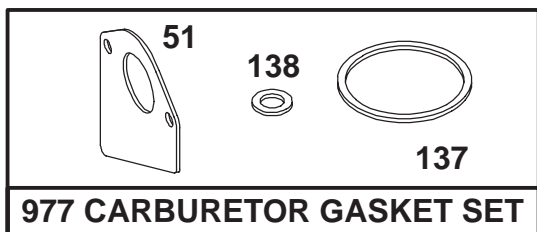

977 CARBURETOR GASKET SET

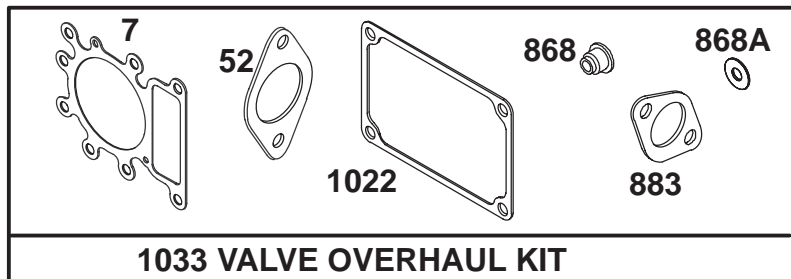

1033 VALVE OVERHAUL KIT

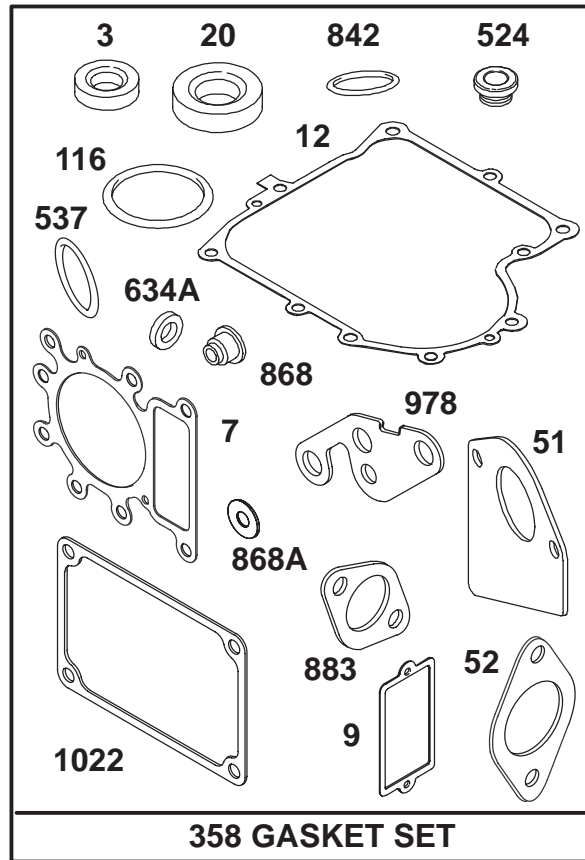

358 GASKET SET

Assemblies include all parts shown in frames.

ENGINE BRIGGS & STRATTON MODEL 28Q777-0668-A1

Ref. No.	Part No.	Description	No. Used
★3	391086	Seal—Oil	1
△★7	272614	Gasket—Cylinder Head	1
★9	27803	Gasket—Valve Cover	1
★12	271916	Gasket—Crankcase (.015" Thick)	1
★	271997	Gasket—Crankcase (.005" Thick)	1
★	271996	Gasket—Crankcase (.009" Thick)	1
★20	291675	Seal—Oil	1
●◆51	272465	Gasket—Carburetor	1
△★52	272569	Gasket—Carburetor	1
●95	94098	Screw—Throttle	1
●104	231789	Pin—Float Hinge	1
●105	231855	Valve—Inlet Needle	1
●106	231854	Seat—Inlet	1
★116	281402	O—Ring	1
●117	231858	Jet—Main	1
121	498116	Carburetor Kit	1
●127		Plug—Welch (Sold in Kit Only).	1

Ref. No.	Part No.	Description	No. Used
●◆137	281165	Gasket—Float Bowl	1
●◆138	281164	Washer—Float Bowl	1
●142	231990	Nozzle—Carburetor	1
●147	231985	Jet—Pilot	1
358	495993	Gasket Set	1
★524	68838	Seal—Fill Tube	1
★537	281106	Gasket—Air Cleaner	1
★634	491323	Seal—Governor	1
●634A	281168	Seal—Choke Shaft	1
●634B	281167	Seal—Throttle Shaft	1
★842	270920	Seal—Oil Fill Cap	1
△★868	494435	Seal—Valve	1
△★868A	272610	Gasket—Valve	1
△★883	272293	Gasket—Exhaust	1
977	494385	Carburetor Gasket Set	1
★978	272888	Gasket—Adapter	1
●987	281166	Seal—Shaft	1
△★1022	272475	Gasket—Rocker Cover	1
1033	495992	Kit—Valve Overhaul	1

★ Included in Gasket Set—Part No. 495993.
 △ Included in Valve Overhaul Kit—Part No. 495992.

● Included in Carburetor Kit—Part No. 498116.
 ◆ Included in Carburetor Gasket Set—Part No. 494385.

TORO PART NUMBER INDEX

Part No.	Description	Pg. Ref. No. No. Qty.	Part No.	Description	Pg. Ref. No. No. Qty.
7228	Bulb – Light	1511:3 2	88-3850	Wheel – Steering	5 1 1
104047	Bushing	6 3:1 1	88-3870	Cover – Steering Wheel	5 1:2 1
104048	Fitting	6 3:2 1	88-3880	Tank – Gas	6 3 1
111419	Washer – Bearing	4 12 1	88-3940	Panel – Rear Hitch	1 5 1
111686	Socket Assembly	1511:2 2	88-3960	Lens – Headlights	15 12 1
114621	Decal – Noise Europe	3 24 1	88-3970	Reflector – Lamp Asm	15 11 1
116397	Relay – S.P.D.T.	15 22 1	88-3980	Cap – Gas	6 27 1
614249	Strap – Tie	2 38 1	88-4040	Box – Battery	15 30 1
701178	Cap – Protector	1 1 2	88-4070	Tire	429:2 2
702366	Clip – Wire Retainer	15 6 1	88-4140	Nut – Wedge	2 23 2
702366	Clip – Wire Retainer	15 21 2	88-4160	Clamp – Pivot Rod	2 24 2
936109	Ring – Retaining	10 36 1	88-4170	Rod – Pivot Tower	2 20 1
9267154	Screw – Hex Washer Hd.	6 8 1	88-4180	Button – Release	5 5 1
3-6498	Washer – Thrust	8 7 2	88-4190	Bushing – Sliding	5 4 1
3-6498	Washer – Thrust	5 17 1	88-4210	Bushing – Stationary	5 19 1
3-6498	Washer – Thrust	4 21 2	88-4230	Trunnion – H.O.C. Rear	14 13 2
3-6498	Washer – Thrust	5 22 1	88-4320	Harness – Wire/Lights	15 18 1
3-6498	Washer – Thrust	4 38 4	88-4340	Throttle Control Assembly	6 1 1
3-7501	Washer – Curved	5 11 4	88-4350	Cable Assembly – Throttle	6 26 1
5-4460	Washer – Fender	3 4 1	88-4370	Rim – Wheel	429:1 2
5-4460	Washer – Fender	6 9 4	88-4390	Rim Asm	8 2:2 2
5-4460	Washer – Fender	4 17 1	88-4400	Bearing – Wheel	429:4 2
5-4460	Washer – Fender	9 20 2	88-4410	Gasket – Muffler	6 18 1
5-4460	Washer – Fender	7 35 1	88-4490	Reducer – Throttle RPM	6 42 1
5-4460	Washer – Fender	12 43 1	88-4620	Bracket – Idler Pivot	1 11 1
7-0030	Bolt – Shoulder	14 11 2	88-4630	Plate – Engine Mounting	1 24 1
7-0030	Bolt – Shoulder	14 18 1	88-4670	Bushing – Eccentric	4 9 1
7-0036	Key – Square	8 3 2	88-4690	Block – Pivot	13 7 1
23-0310	Bolt – Shoulder	13 8 1	88-4730	Clamp – H.O.C. Pivot	14 16 2
26-0671	Bolt – Blade	6 12 1	88-4810	Clamp – Shift Pivot	7 13 1
26-6701	Spring – Extension	9 15 1	88-4820	Bracket – Seat Hinge	3 11 2
27-0220	Screw – Hex Washer Hd.	6 2 2	88-4880	Spacer – Microswitch	15 17 1
27-0220	Screw – Hex Washer Hd.	5 15 2	88-4890	Spring – Leaf	5 10 1
27-0220	Screw – Hex Washer Hd.	6 19 2	88-4910	Support – Seat	3 3 1
27-8890	Spring – Pedal Return	7 1 1	88-4990	Tray – Fender	3 23 1
28-0540	Bolt – Shoulder	2 6 2	88-5000	Pedal – Clutch/Brake	7 21 1
28-2480	Washer – Flat	8 4 2	88-5010	Spacer – Steering Rack	4 7 1
28-2480	Washer – Flat	4 28 2	88-5030	Gate – H.O.C.	3 9 1
28-8080	Boot – Battery Terminal	15 1 1	88-5130	Bracket – Steering Rack	4 5 1
37-8770	Bolt – Shoulder	3 1 2	88-5150	Bushing – Flange	5 16 1
37-8770	Bolt – Shoulder	3 2 2	88-5180	Bracket – Backup	5 8 1
37-8770	Bolt – Shoulder	7 31 1	88-5190	Lever – Deck Engage	2 25 1
37-8771	Bolt – Shoulder	13 15 1	88-5200	Rack – Steering	4 10 1
38-1420	Switch – Seat	15 5 1	88-5230	Mat – Foot R.H. Hydro	3 17 1
44-8110	Cable – Battery Negative	15 4 1	88-5240	Mat – Foot L.H.	3 16 1
46-8090	Screw – Plastic	2 13 4	88-5270	Rod – Clutch/Brake	7 29 1
46-8090	Screw – Plastic	2 17 3	88-5360	Spacer – Pulley	8 1 2
46-8090	Screw – Tapping	13 5 2	88-5450	Rod – Hanger Rear	14 12 2
46-8091	Screw – Plastic	2 10 1	88-5470	Spacer – Front Axle	4 23 2
46-8091	Screw – Tapping	2 3 2	88-5500	Rod – Pedal Pivot	7 15 1
47-2963	Line – Fuel	6 4 1	88-5510	Rod – Parking Brake	4 35 1
48-7620	Screw	9 3 1	88-5520	Bracket – Parking Brake	4 36 1
52-2891	Bushing – Steering Links	4 11 1	88-5560	Guide – Belt Idler	7 32 1
56-2540	Tube – Vent	15 29 1	88-5570	Link – Adjusting H.O.C.	14 6 4
61-9780	Cap – Hub	8 6 2	88-5610	Lever – Neutral Return	13 14 2
61-9780	Cap – Hub	4 26 2	88-5680	Pulley – Flat Idler	7 33 1
63-8360	Key – Ignition	15 25 1	88-6040	Bracket – Hinge R.H.	2 18 1
65-2920	Pad – Pedal	7 20 1	88-6050	Bracket – Hinge L.H.	2 7 1
65-5080	Bushing – Flanged	9 22 1	88-6070	Arm – Idler	7 30 1
65-7210	Spacer	14 23 1	88-6090	Coupling – Steering	5 20 1
66-0120	Knob	6 1:1 1	88-6140	Spring – Brake	7 2 1
80-2240	Plate – Name Grille	15 31 1	88-6220	Spring – Compression	1 4 2
80-2600	Battery – 7 Plate	15 3 1	88-6300	Shaft – Steering Upper	5 13 1
80-6090	Key – Square	9 28 1	88-6330	Spring – Extension	7 7 1
80-6990	Washer – Hardened	14 8 2	88-6370	Shaft – Steering S	5 14 1
86-4270	Spacer – Lock	911:4 1	88-9830	Switch – Ignition	15 24 1
86-4270	Spacer	10 103 1	88-9932	Switch – Micro	15 19 2
88-0890	Grip – Parking Brake	4 37 1	92-2467	Decal – Hood R.H.	2 34 1
88-3840	Body – Rear	1 28 1	92-2468	Decal – Hood L.H.	2 33 1

*Not Illustrated

TORO PART NUMBER INDEX (Cont.)

Part No.	Description	Pg. Ref. No. No. Qty.	Part No.	Description	Pg. Ref. No. No. Qty.
92-5730	Decal - Throttle Int'l	2 31 1	94-1900	Housing - Lower	12 1 1
92-5731	Decal - Ignition/Lights Int'l	2 30 1	94-1901	Housing Asm - Upper	10 2 1
92-5782	Patch - Head Tape	2 15 1	94-1902	Ring - Wire Retaining	10 4 1
92-6511	Seat - High Back V511	3 25 1	94-1903	Ring - Retaining	10 5 1
92-6543	Seal - Lip	10 3 1	94-1904	Bearing - Shaft Ball	10 6 1
92-6544	Seal - Lip	10 15 1	94-1905	Bearing - Cradle	10 7 2
92-6545	Seal - Lip	10 24 1	94-1907	Swashplate - Variable	10 9 1
92-6547	Arm - Bypass	10 35 1	94-1908	Block - Cylinder Asm	10 13 1
92-6549	Pin - Actuating	12 38 1	94-1909	Arm - Trunion	10 14 1
92-7305	Spring - Extension	13 11 1	94-1910	Guide - Slot	10 17 1
92-7889	Spindle - R.H.	4 30 1	94-1913	Block - Cylinder Asm	12 23 1
92-8650	Hood - TORO	2 14 1	94-1914	Actuator - Bypass	12 25 1
92-8856	Wire - Bypass	9 8 1	94-1915	Centersection Asm	12 26 1
92-8857	Lever - Bypass	9 26 1	94-1916	Seal - Lip	12 27 1
92-8875	Switch - Rocker Lights	15 26 1	94-1917	Ring - Retaining	12 28 1
92-9674	Knob - Studded	3 5 1	94-1918	Washer	12 29 2
92-9845	Solenoid	15 8 1	94-1919	Brake Rotor/Starter Kit	12 41 4
93-0303	Tower - Steering	2 1 1	94-1920	Oil Filter Element	12 34 1
93-0323	Tire	8 2:1 2	94-1921	Differential Asm	11 44 1
93-0539	Screw - Phillips Pan Hd.	15 15 4	94-1922	Washer	11 52 2
93-3240	Seal - Plunger	15 20 1	94-1923	Bolt	12 39 1
93-3807	Nut - Castle	12 134 1	94-1924	Seal	11 53 2
93-3808	Spring - Extension	14 17 1	94-1925	Shaft - Input	10 56 1
93-3809	Bracket - Ground	6 31 1	94-1926	Bolt	12 58 21
93-3810	Harness - Wire	15 23 1	94-1927	Pin	12 59 2
93-3812	Pedal - Speed Control	13 9 1	94-1930	Jackshaft/Pinion Gear Asm	12 83 1
93-3822	Lever - H.O.C.	14 1 1	94-1932	Capscrew	12 88 2
93-3831	Support - Rear	1 38 1	94-1933	Washer	12 89 2
93-3832	Pulley - Engine	6 11 1	94-1934	Sleeve - Bearing	11 90 2
93-3833	Spindle - L.H.	4 18 1	94-1935	Seal - Wiper	11 91 2
93-3834	Support - Front Axle	1 21 1	94-1936	Spring - Block	10 92 1
93-3840	Link - Drag	4 34 1	94-1937	Washer - Block Thrust	10 93 1
93-3849	Bracket - Cable Upper	2 37 1	94-1945	Hose - Breather	9 29 1
93-3854	Guide - Belt	6 7 3	94-1951	Latch - Hood	6 44 1
93-3855	Guide - Belt R.H.	6 22 1	94-1952	Rod - Gas Tank	6 24 1
93-3856	Bracket - Trans. Mtg. R.H.	1 36 1	94-1980	Foam - Hood	2 39 2
93-3857	Bracket - Trans. Mtg. L.H.	1 10 1	94-1984	Pin - Latch	2 11 1
93-3861	Lever - Brake	12 37 1	94-1990	Axle - Front	4 31 1
93-3862	Pulley - Transmission	9 7 1	94-1998	Frame - Rail R.H.	1 25 1
93-3863	Bracket - Speed Control	9 21 1	94-1999	Frame - Rail L.H.	1 13 1
93-3864	Shield - Heat	2 16 1	94-3526	Decal - Engine 15 TQPLUS	6 29 1
93-3867	Fan - Hydro	9 5 1	94-3528	Decal - Tower 1544HXL	2 29 2
93-3868	Guide - Trans. Belt	9 17 2	94-3530	Decal - Rear Body 1644	1 35 1
93-3870	Control Arm	10 100 1	94-4292	Cable - Deck Engage	2 35 1
93-3870	Lever Asm - Speed Control	911:3 1	94-4909	Trim - Seat	325:1 1
93-3872	Strap - Torque	9 9 1	94-5362	Boot - Terminal Insulator	15 33 1
93-3873	Rod - Tie	4 32 1	94-5565	Knob - Control	2 2 1
93-3874	Link - Speed/Direct Control	13 18 1	94-5565	Knob - Control	14 24 1
93-3875	Bellcrank	13 16 1	94-6922	Bearing - Thrust	10 8 1
93-3877	Rod - Speed Control	13 13 1	94-6923	Bearing - Thrust	12 19 1
93-3880	Shield - Muffler	6 32 1	94-6925	Bypass Plate	12 30 1
93-3882	Clip - Tinnerman	6 34 1	94-6926	Bolt	12 57 3
93-3883	V-Belt - Hydro	9 18 1	94-6946	Transaxle Asm - Hydro	9 11 1
93-3885	Tube	14 3 1	94-6955	Shaft - Motor	12 18 1
93-3888	Link - H.O.C.	14 10 1	94-6956	Jackshaft	12 85 1
93-3891	Duct - Hood Air	2 12 1	218-461	Nut - Hex	1524:2 1
93-3892	Muffler	6 15 1	218-560	Cap - Battery	16 3 6
93-3893	Inner Tube (Optional)	8 2:4 2	232-27	Stem & Valve	429:3 2
93-6668	Decal - Battery Charge Inst.	16 2 1	232-27	Valve Stem	8 2:3 2
93-6673	Decal - Deck Engage Int'l	2 32 1	232-39	Tube - Inner	429:6 2
93-6676	Decal - Instruction	1 33 1	2412-98	Clamp - Hose	6 5 2
93-6678	Decal - Dump Valve Hydro	1 31 1	302-5	Fitting - Grease	429:5 2
93-7276	Decal - Danger	16 1 1	302-26	Fitting - Grease	4 8 1
93-7657	Cover - H.O.C. Int'l	3 7 1	321-2	Screw - Hex Hd. Cap	2 5 4
93-7660	Pivot - H.O.C.	14 22 1	321-4	Screw - Hex Hd. Cap	15 2 2
93-8450	Shield - Exhaust	6 33 1	321-4	Screw - Hex Hd. Cap	5 7 2
93-8741	Reflector - Headlight	1511:1 1	321-9	Screw - Hex Hd. Cap	5 21 2
93-9354	Decal - Battery	16 4 1	322-3	Screw - Hex Hd. Cap	1 7 4
93-9911	Arrestor - Spark	6 40 1	322-3	Screw - Hex Hd. Cap	1 9 4

*Not Illustrated

TORO PART NUMBER INDEX (Cont.)

Part No.	Description	Pg. No.	Ref. No.	Qty.	Part No.	Description	Pg. No.	Ref. No.	Qty.
322-3	Screw - Hex Hd. Cap	3	10	4	3290-307	Pin - Hair Cotter	14	7	2
322-3	Screw - Hex Hd. Cap	7	14	2	3290-307	Pin - Hairpin Cotter	2	19	2
322-3	Screw - Hex Hd. Cap	9	16	1	3290-354	Nut - Speed	15	16	2
322-3	Screw - Hex Hd. Cap	14	19	4	3290-456	Washer - Belleville	13	17	1
322-3	Screw - Hex Hd. Cap	1	20	6	3290-479	Fastener - Panel	3	6	4
322-3	Screw - Hex Hd. Cap	1	23	2	3290-479	Fastener - Panel	3	15	12
322-3	Screw - Hex Hd. Cap	1	26	4	3290-496	Nut - Retained	2	8	2
322-3	Screw - Hex Hd. Cap	1	27	2	3296-5	Nut - Lock	4	20	3
322-3	Screw - Hex Hd. Cap	2	28	2	3296-12	Nut	10	102	1
322-3	Screw - Hex Hd. Cap	6	39	1	3296-12	Nut - Lock	911	6	1
322-5	Screw - Hex Hd. Cap	9	19	2	3296-20	Nut - Lock Insert	12	140	1
322-5	Screw - Hex Hd. Cap	1	2	2	3296-29	Nut - Hex Lock	1	12	4
322-5	Screw - Hex Hd. Cap	6	10	2	3296-29	Nut - Lock	4	1	4
322-9	Screw - Hex Hd. Cap	14	2	1	3296-29	Nut - Lock	1	6	2
322-9	Screw - Hex Hd. Cap	6	6	3	3296-29	Nut - Lock	1	8	4
322-12	Screw - Hex Hd. Cap	9	32	4	3296-29	Nut - Lock	9	10	2
323-11	Screw - Hex Hd. Cap	7	34	1	3296-29	Nut - Lock	3	12	6
323-13	Screw - Hex Hd. Cap	4	2	2	3296-29	Nut - Lock	9	13	5
3218-2	Nut - Hex Jam	14	25	1	3296-29	Nut - Lock	1	14	2
3230-1	Screw - Carriage	4	6	4	3296-29	Nut - Lock	14	14	4
3230-3	Screw - Carriage	4	4	1	3296-29	Nut - Lock	1	15	6
3230-3	Screw - Carriage	7	22	1	3296-29	Nut - Lock	14	15	2
3230-5	Bolt - Carriage	9	23	1	3296-29	Nut - Lock	1	16	2
3230-7	Bolt - Carriage	9	24	1	3296-29	Nut - Lock	4	16	1
3231-4	Screw - Carriage	4	3	1	3296-29	Nut - Lock	6	16	2
3253-4	Washer - Lock	6	21	2	3296-29	Nut - Lock	7	19	1
3253-4	Washer - Spring Lock	6	38	1	3296-29	Nut - Lock	14	20	1
3253-22	Washer - Lock	6	13	1	3296-29	Nut - Lock	14	21	1
3254-5	Washer - Lock	1524	1	1	3296-29	Nut - Lock	6	25	2
3255-7	Washer - Lock	15	14	1	3296-29	Nut - Lock	2	26	2
3255-8	Washer - Lock	6	36	1	3296-29	Nut - Lock	7	26	2
3256-22	Washer - Flat	13	6	2	3296-29	Nut - Lock	7	27	1
3256-22	Washer - Flat	5	6	2	3296-29	Nut - Lock	9	27	4
3256-22	Washer - Flat	9	25	1	3296-29	Nut - Lock	1	29	4
3256-23	Washer - Flat	13	2	4	3296-39	Nut - Lock	4	15	1
3256-23	Washer - Flat	1	3	2	3296-39	Nut - Lock	4	25	2
3256-23	Washer - Flat	9	14	3	3296-42	Nut - Lock	2	4	4
3256-23	Washer - Flat	1	22	2	3296-42	Nut - Lock	5	9	2
3256-23	Washer - Flat	7	23	1	3296-42	Nut - Lock	5	12	2
3256-23	Washer - Flat	2	27	2	3296-47	Nut - Lock	13	19	1
3256-23	Washer - Flat	9	33	4	3296-59	Nut - Lock	13	10	1
3256-24	Washer - Flat	14	5	2	3296-59	Nut - Lock	7	28	2
3256-24	Washer - Flat	2	21	2	32103-22	Nut - Wing Nylon	15	28	2
3256-24	Washer - Flat	4	24	2	32104-76	Screw - Self Tapping	6	35	2
3256-25	Washer - Flat	4	13	1	32104-76	Screw - Self Tapping	6	43	2
3256-25	Washer - Flat	6	14	1	32121-111	Pin - Roll	5	2	1
3256-26	Washer - Flat	7	18	1	32128-43	Nut - Flange	2	22	2
3256-58	Washer - Flat	9	4	1	32144-4	Screw - Tapping	15	9	2
3269-26	Washer	3	13	2	32144-4	Screw - Tapping	15	13	1
3272-7	Pin - Cotter	12	135	1	32144-4	Screw - Tapping	6	17	2
3272-10	Pin - Cotter	4	14	1	32144-4	Screw - Tapping	2	36	2
3272-10	Pin - Cotter	7	24	1	32144-4	Screw - Tapping	6	37	1
3272-12	Pin - Cotter	4	27	2	32144-32	Screw - Plastic	15	10	2
3274-10	Screw - Socket Hd.	6	20	2	32144-42	Screw - Hex Hd. Tapping	6	41	1
3274-59	Screw - Cap Socket Hd.	10	101	1	32149-1	Nut - Keps	6	23	2
3274-59	Screw - Hex Socket Hd.	911	5	1	32149-2	Nut - Lock Keps	15	7	3
3290-282	Rivet - Pop	3	8	2	32151-48	Ring - Retaining	8	5	2
3290-299	Nut - Tinnerman	15	32	1	32151-48	Ring - Retaining	5	18	1
3290-307	Pin - Hair Cotter	13	1	4	32151-48	Ring - Retaining	4	33	2
3290-307	Pin - Hair Cotter	9	1	1	32151-81	Ring - Retaining	5	3	1
3290-307	Pin - Hair Cotter	14	4	1	32151-83	Ring - Retaining	13	12	1

*Not Illustrated

PRODUCT CHANGES

In an effort to make improvements available to TORO owners as quickly as possible, minor changes are incorporated into Toro's products from time to time that do not become immediately shown in the Parts Catalog. If such a change has been made in your unit, which is not reflected in your manual, see your TORO Distributor or his Authorized TORO Service Dealer for information and part numbers.

COUNTRIES OTHER THAN THE UNITED STATES OR CANADA

Customers who have purchased TORO products exported from the United States or Canada should contact their Toro Distributor (Dealer) to obtain guarantee policies for your country, province or state. If for any reason you

are dissatisfied with your Distributor's service or have difficulty obtaining guarantee information, contact the TORO importer. If all other remedies fail, you may contact us at The Toro Company.

IDENTIFICATION AND ORDERING

MODEL AND SERIAL NUMBERS

The Lawnmower has two identification numbers; a model number and a serial number. The two numbers are stamped on a decal which is located on the rear of the housing. In any correspondence concerning the lawnmower, supply model and serial numbers to assure that correct information and replacement parts are obtained.

To order replacement parts from an Authorized TORO Service Dealer, supply the following information:

1. Model and serial number of the lawnmower.
2. Part number, description, and the quantity of part(s) desired.

NOTE: Do not order by reference number if a parts catalog is being used; use the PART NUMBER.

TABLE OF CONTENTS

Description	Page	Description	Page
Frame Assembly	1	Engine Briggs & Stratton	
Hood Assembly	2	Model 28Q777–0668–A1	18–27
Seat Assembly	3	TORO Numerical Index	28–31
Front Axle Assembly	4		
Steering Assembly	5	OPTIONAL EQUIPMENT	
Engine Assembly	6	Twin Bag Vac. Bagger Kit	Model No. 79102
Clutch Assembly	7	Recycler Kit (Std. this Model)	Model No. 79174
Rear Axle Assembly	8	Hi–Sail Baggin Blade	Part No. 57–4940
Transaxle Assembly	9	Tire Chains	Model No. 82522
Hydro Transaxle Assembly	10–12	Headlight Kit (Std. This Model)	Model No. 79180
Speed Control Assembly	13	42" Snowblade Kit	Model No. 79150
Height of Cut Assembly	14	Snow Blade Adapter Kit	Part No. 93–3806
Electrical Assembly	15	Wheel Weight Kit	Model No. 59159
Battery Assembly	16	44" Side Discharge Deck	Model No. 79107
Electrical Schematic	17		

