

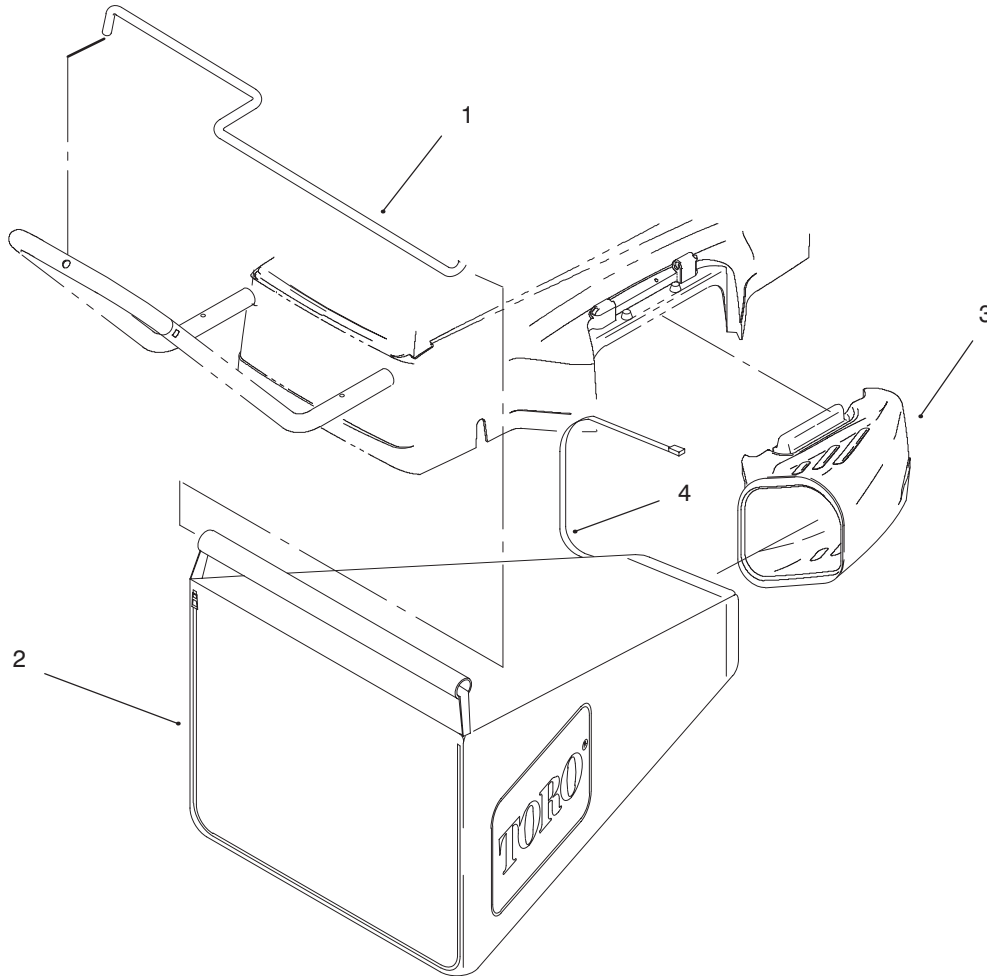

MODEL NO. 59294

PARTS  
CATALOG

**18" ELECTRIC WPM BAGGING KIT**



C-2472

**BAG KIT ASSEMBLY**

Ref. No.	Part No.	Description	No. Used
1	93-3993	Rod - Bag	1
2	94-1150	Bag Assembly	1

Ref. No.	Part No.	Description	No. Used
3	93-3964	Chute - Bag	1
4	94-3890	Wire Tie	1