



**Count on it.**

**Parts Catalog**

**Workman® MDE Utility Vehicle**

Model No. 07299TC—Serial No. 310000001 and Up

# Ordering Replacement Parts

To order replacement parts, please supply the part number, the quantity, and the description of each part desired.

## Understanding Reference Numbers

Each identified part in an illustration has a reference number. The reference number for a part also appears in the parts list, along with other information about the part.

This catalog uses two special reference number formats, one to indicate parts in a service assembly and another to indicate the quantity of a given part in an illustration.

## Service Assembly Reference Numbers

Parts in service assemblies have reference numbers in the form a:b. The a represents the reference number of the entire service assembly and the b represents a sequential number unique to each part within the service assembly.

For example, a wheel assembly might be identified by reference number 6, the tire by 6:1, the valve by 6:2, and the wheel by 6:3. When you order the assembly identified by reference number 6, you receive all parts identified by reference numbers 6:1, 6:2, and 6:3. However, you may also order any part individually. Reference numbers of this type appear in illustration and in parts lists.

## Reference Numbers Indicating Quantity

In an illustration, if a reference number indicates more than one part, the reference number has the form nX y. The n represents the quantity of the part, the X is the multiplication symbol, and the y represents the reference number.

For example, in an illustration, the reference number 2X 37 means that two of the parts identified by reference number 37 are indicated.

# List of Abbreviations

**AR:** as required

**ASM:** assembly

**BBC:** blade brake control

**BHTF:** button head thread forming

**CARR:** carriage

**CCW:** counter clockwise

**CW:** clockwise

**DEG:** degrees

**ECM:** electronic control module

**EXT:** external

**FH:** flat head

**GA:** gauge

**HD:** heavy-duty

**HF:** hex flange

**HH:** hex head

**HHF:** hex head flange

**HHFTF:** hex head flange thread forming

**HJ:** hex jam

**HLH:** hex lag head

**HOC:** height-of-cut

**HSBH:** hex socket button head

**HSFH:** hex socket flat head

**HSH:** hex socket head

**HWH:** hex washer head

**HWHTF:** hex washer head thread forming

**HYD:** hydraulic

**LH:** left hand

**NI:** nylon insert

**NPTF:** national pipe thread fine

**PFH:** phillips flat head

**PPH:** phillips pan head

**PPHTF:** phillips pan head thread forming

**PRH:** phillips round head

**PTH:** phillips truss head

**PTO:** power-take-off

**RH:** right hand

**ROPS:** roll-over protection system

**RRB:** rear roller brush

**SFH:** slotted fillister head

**SHH:** slotted hex head

**SHWH:** slotted hex washer head

**SPH:** slotted pan head

**SQH:** square head

**SRH:** slotted round head

**STD:** standard

**TAP:** self tapping

**TTH:** torx truss head

# Contents

Dash Assembly .....	4
Solenoid Assembly No. 104-7135 .....	5
Pedal Box Assembly .....	6
Master Cylinder and Brake Line Assembly .....	7
Master Cylinder Assembly No. 104-6782 .....	8
Frame Assembly .....	9
Seat Base Assembly .....	10
Offboard 48 Volt Charger Assembly No. 112-2914 .....	11
Front Tire, Spindle and Tie Rod Assembly .....	12
Controller Assembly .....	13
Battery and Transaxle Assembly .....	14
Electric Motor Assembly No. 104-7335 .....	15
Electric Transaxle Assembly No. 114-8330 .....	16
LH Rear Brake Assembly No. 114-8332 .....	17
RH Rear Brake Assembly No. 114-8331 .....	18
Upper Steering Assembly .....	19
Steering Box Assembly No. 112-3130 .....	20
Box and Tailgate Installation Assembly .....	21
Box and Tailgate Assembly .....	22
Hood and Fender Assembly .....	23
Attachments and Accessories .....	24

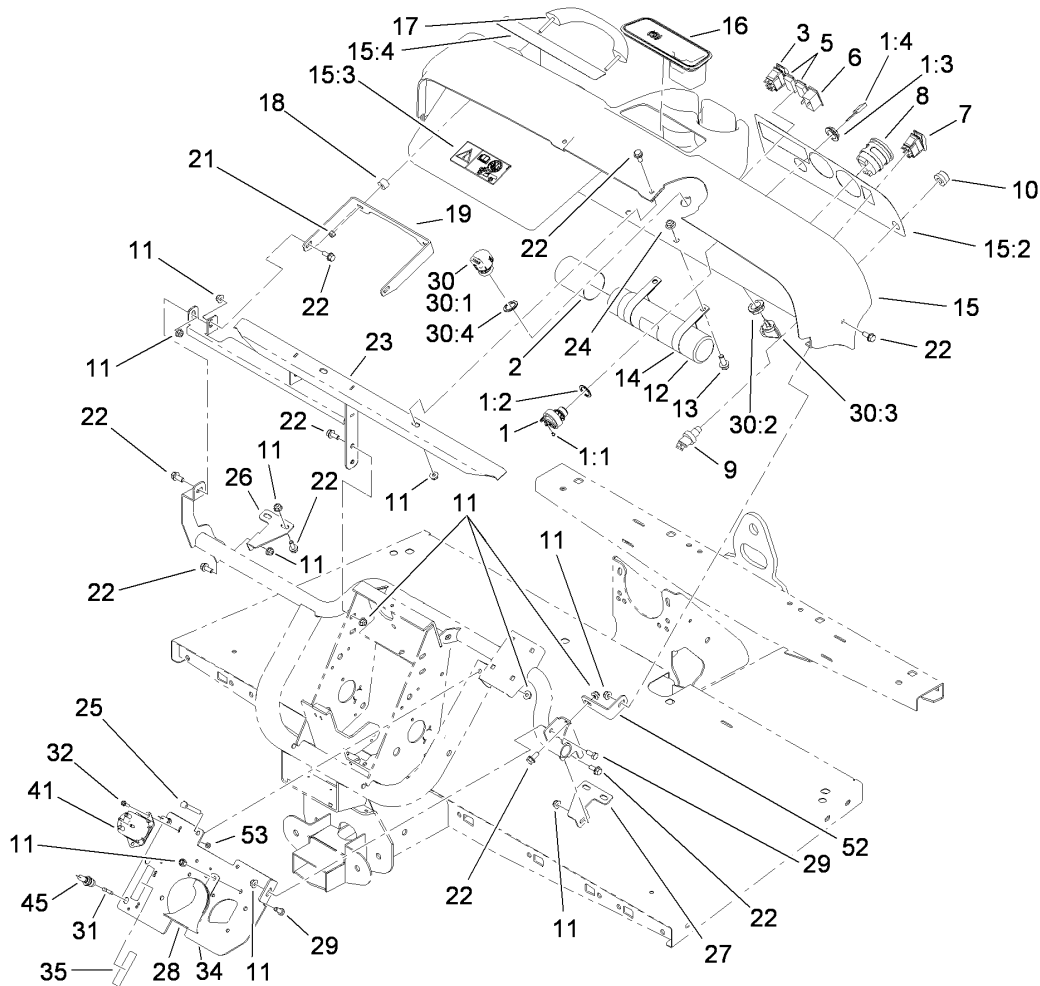

## Dash Assembly

Ref.	Part Number	Qty.	Description	Ref.	Part Number	Qty.	Description
1	107-0348	1	Switch-Key, 48V	18	114-8301	2	Spacer
1:1	3250-28	3	Screw	19	112-3391-03	1	Bracket-Grip, Handle
1:2	108-8659	1	Washer-Backup	21	104-7201	2	Nut-HF
1:3	108-8660	1	Nut-Mounting	22	110-5053	15	Screw-Flange
1:4	108-6994	1	Key-Ignition	23	115-7651-03	1	Dash Support ASM
2	104-7048	1	Cap-Housing	24	104-8301	2	Nut-Flange, NI
3	107-0255	1	Switch	25	322-11	2	Screw-HH
5	99-7420	2	Plug-Hole	26	114-8304	1	Bracket-Dash Mount, RH
6	104-7129	1	Light-Indicator	27	114-8312	1	Bracket-Dash Mount, LH
7	107-0747	1	Switch-Rocker	28	107-0358	1	Horn
8	107-0260	1	Guage-Hour/Battery Level, 48 Volt	29	322-3	2	Screw-HH
9	112-3324	1	Switch-Horn	30	110-2580	1	Switch-Key, Supervisor
10	112-3313	1	Cap And Nut ASM	30:1		1	Switch-Key ●
11	104-8300	19	Nut-Flange, NI	30:2	108-8660	1	Nut-Mounting
12	104-7050	1	Tube-Manual	30:3	110-5221	1	Set-Key, Supervisor
13	3234-11	2	Screw-HHF	30:4	108-8659	1	Washer-Backup
14	2412-133	2	R-Clamp	31	98-8876	2	Fuse-10 Amp
15	114-8311	1	Dash ASM	32	32105-13	2	Screw-HWH
15:2	112-3310	1	Decal-Dash, Ce	34	112-3376-03	1	Plate-Mount, Electrical
15:3	104-7215	1	Decal-Danger	35	115-7621	1	Decal-Electrical
15:4	115-2412	1	Decal-No Storage	41	104-7135	1	Solenoid
16	104-6930	1	Plug-Rubber	45	218-489	2	Holder-Fuse
17	112-3320	1	Handle-Grip	52	114-8305	1	Angle-Mount, Dash (LH)
				53	3296-2	2	Nut-Lock, NI

● Not serviced separately

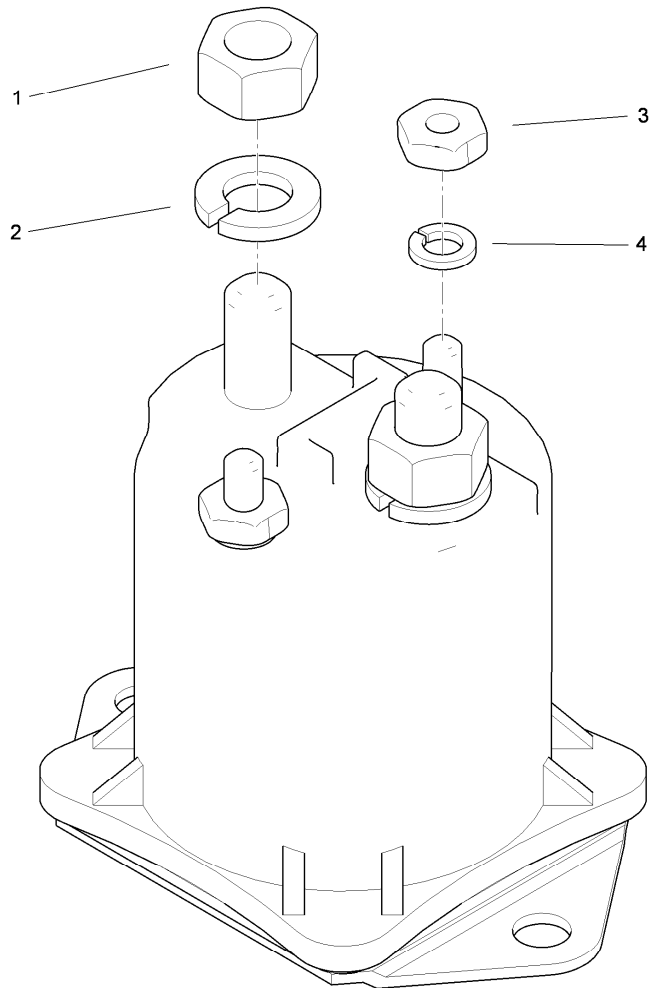

## Solenoid Assembly No. 104-7135

<i>Ref.</i>	<i>Part Number</i>	<i>Qty.</i>	<i>Description</i>
1	3217-6	2	Nut-Hex
2	3253-4	2	Washer-Lock
3	3219-14	2	Nut-Hex
4	3253-17	2	Washer-Lock

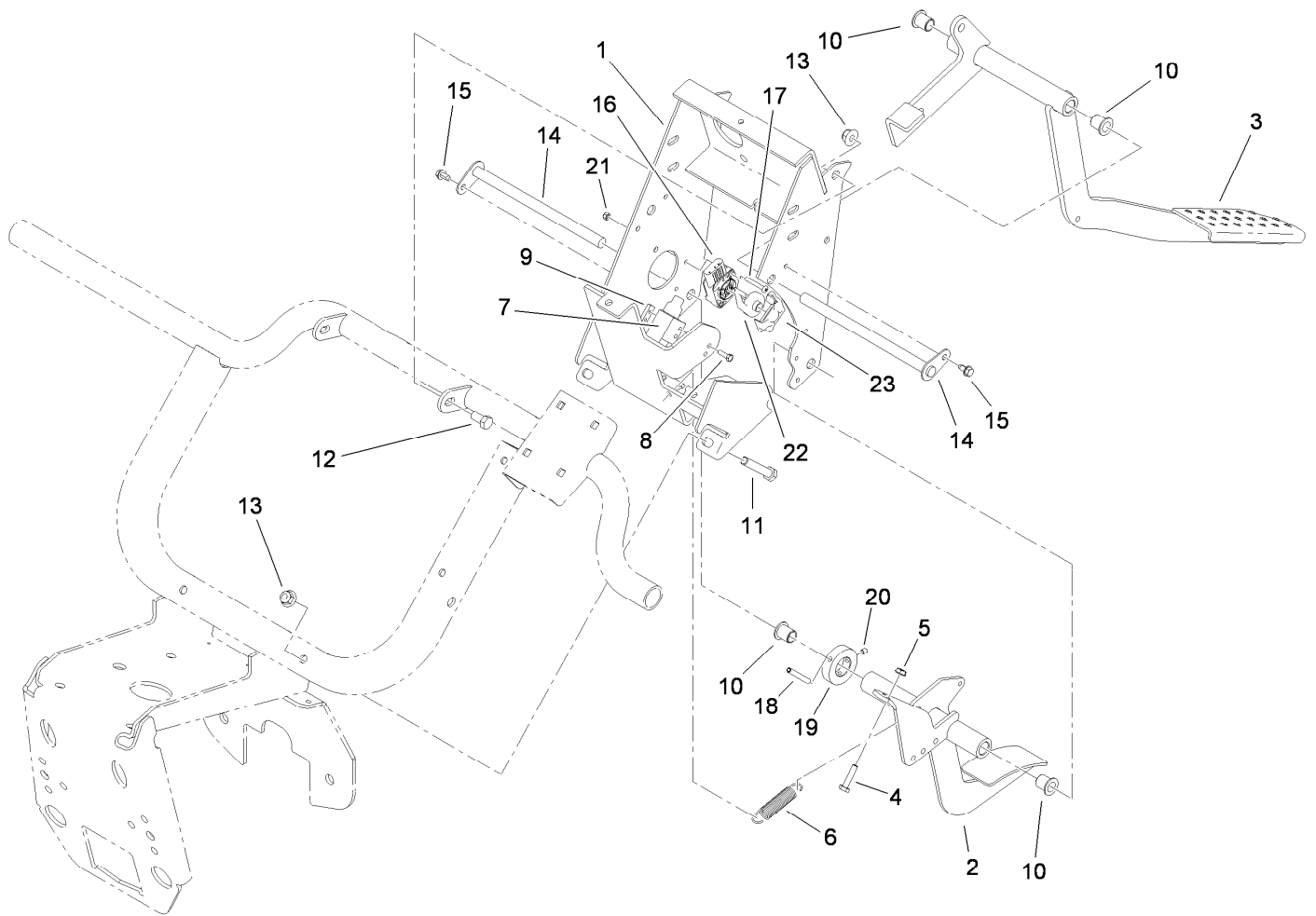

## Pedal Box Assembly

<i>Ref.</i>	<i>Part Number</i>	<i>Qty.</i>	<i>Description</i>	<i>Ref.</i>	<i>Part Number</i>	<i>Qty.</i>	<i>Description</i>
1	119-0748-03	1	Pedal Support Frame ASM	13	104-8301	4	Nut-Flange, NI
2	115-7630-03	1	Throttle Pedal ASM	14	104-7164	2	Pivot-Pedal
3	112-3314-03	1	Brake Pedal ASM	15	12-3270	2	Screw
4	321-7	2	Screw-HH	16	119-0737	1	Sensor-Position, Rotary
5	32149-2	2	Nut-Keps	17	104-1452	2	Screw-PPH
6	104-6415	1	Spring-Return, Pedal	18	117-5071	1	Pin-Roll
7	99-7407	1	Switch	19	104-7301	1	Collar
8	3290-134	2	Screw	20	3245-32	2	Screw-HSH
9	1-633181	1	Plate-Tapped	21	3296-1	2	Nut-Lock
10	256-155	4	Bushing-Flange	22	117-5059	1	Pivot-Sensor, Speed
11	323-11	2	Screw-HH	23	117-5061	1	Retainer
12	323-4	2	Screw-HH				

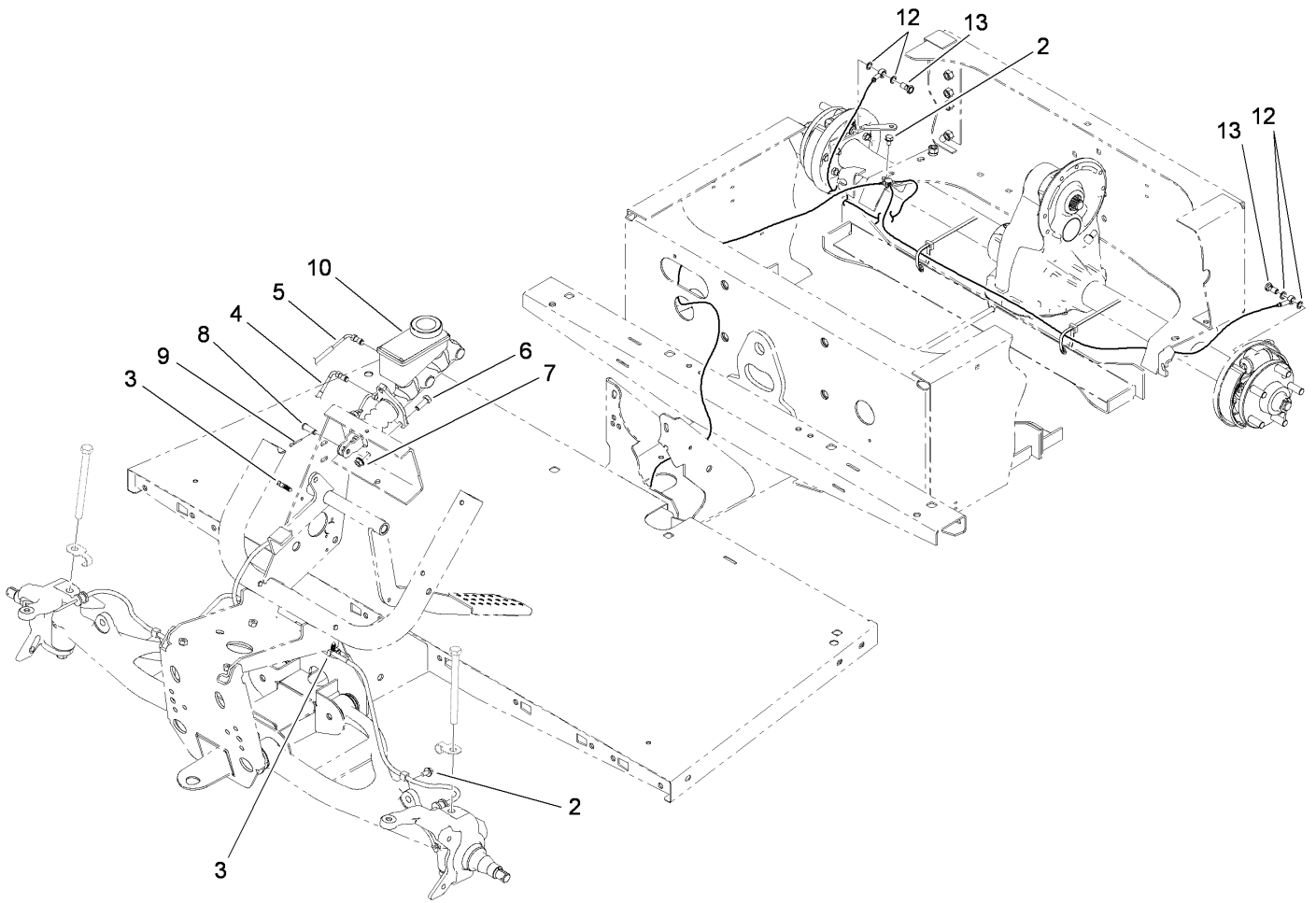

## Master Cylinder and Brake Line Assembly

<i>Ref.</i>	<i>Part Number</i>	<i>Qty.</i>	<i>Description</i>
2	32104-82	3	Screw-HHF
3	114-8324	4	Clip-Line, Brake
4	112-2925	1	Front Brake Line ASM
5	115-2409	1	Rear Brake Line ASM
6	323-6	2	Screw-HH
7	3290-357	2	Nut-HHF, Whiz
8	283-2	1	Pin-Clevis
9	3272-10	1	Pin-Cotter
10	104-6782	1	Cylinder-Master
12	115-2341	4	Washer-Banjo
13	115-2340	2	Bolt-Banjo

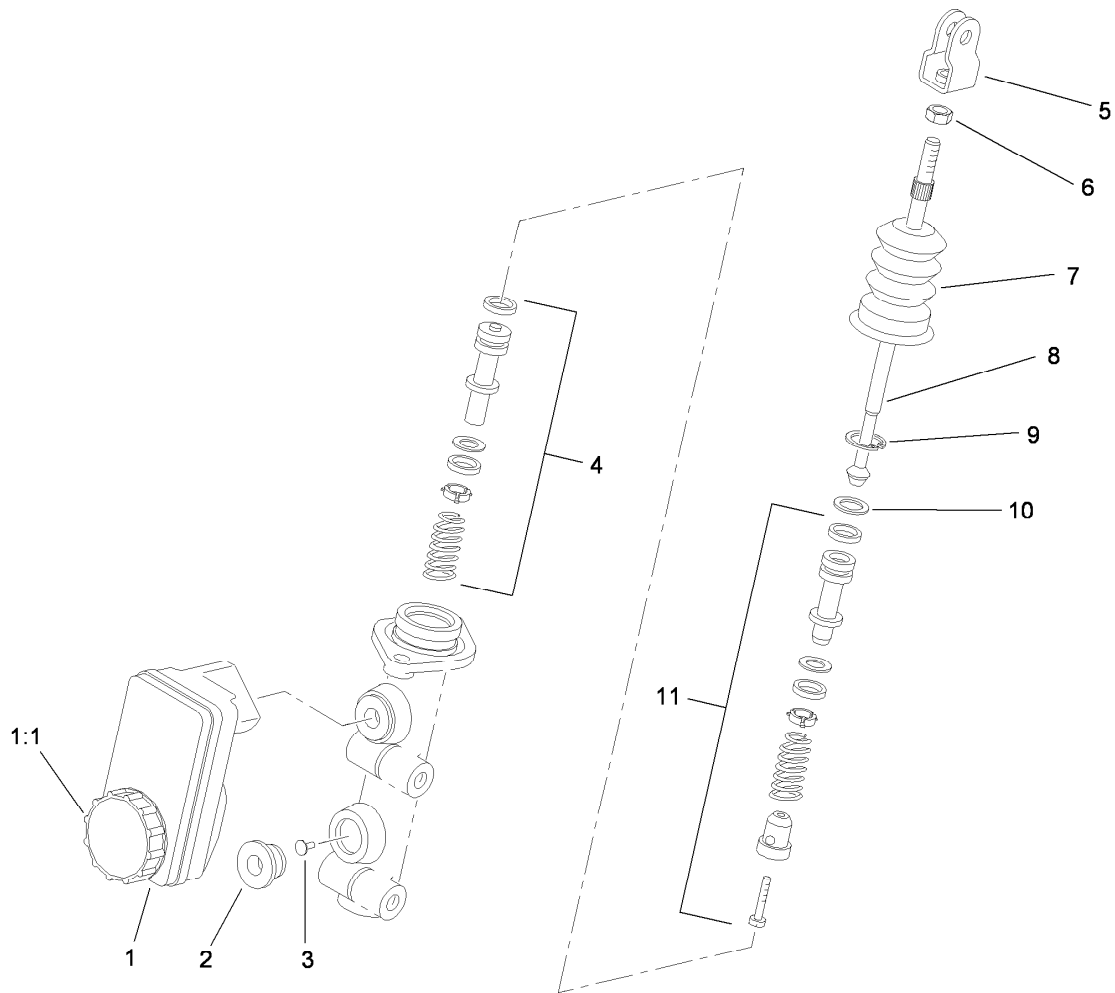

## Master Cylinder Assembly No. 104-6782

<i>Ref.</i>	<i>Part Number</i>	<i>Qty.</i>	<i>Description</i>
1	104-6845	1	Reservoir ASM
1:1	92-4112	1	Cap ASM
2	93-8971	2	Seal-Port, Flange
3	92-4103	1	Pin-Stop
4	92-4102	1	Secondary Piston ASM
5	92-4110	1	Clevis
6	21-0360	1	Nut-Hex
7	94-5209	1	Cover-Dust
8	94-5210	1	Rod-Push
9	92-4109	1	Ring-Snap
10	92-4108	1	Retainer-Washer
11	92-4101	1	Primary Piston ASM

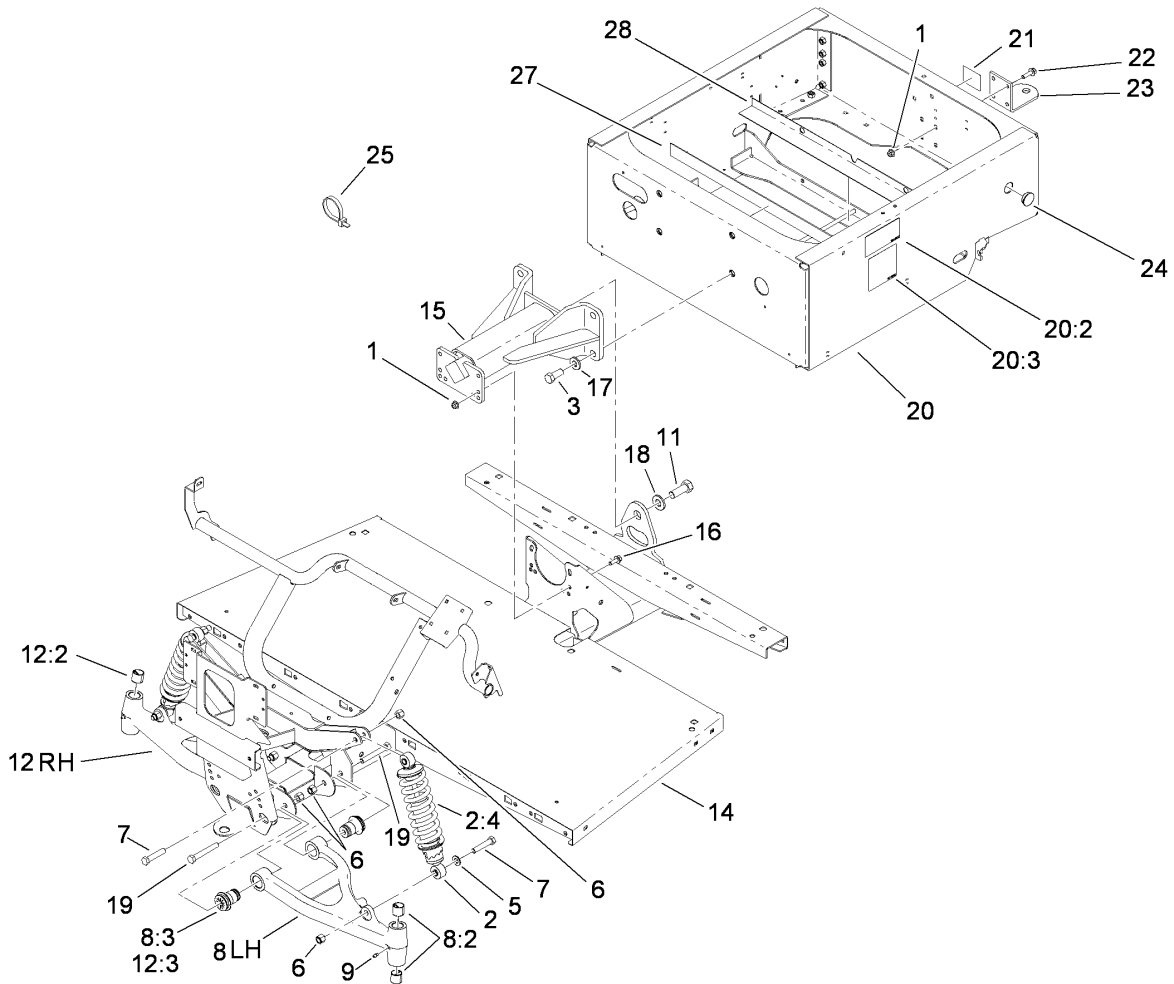

## Frame Assembly

<i>Ref.</i>	<i>Part Number</i>	<i>Qty.</i>	<i>Description</i>	<i>Ref.</i>	<i>Part Number</i>	<i>Qty.</i>	<i>Description</i>
1	104-8301	8	Nut-Flange, NI	15	99-7700	1	Pivot Yoke ASM
2	112-2975	2	Shock/Spring ASM	16	3234-11	4	Screw-HHF
2:4	112-3383	1	Spring	17	99-7667	4	Washer-Flat
3	327-4	4	Screw-HH	18	87-3060	1	Washer-Hardened
5	51-3500	2	Washer	19	325-14	4	Screw-HH
6	3296-23	8	Nut-Lock, NI	20	112-3018	1	Rear Frame ASM
7	325-10	4	Screw-HH	20:2	104-7207	2	Decal-Electric
8	114-8313	1	LH A-Arm ASM	20:3	107-0257	1	Decal-Polarity
8:2	3-0348	2	Bushing	21	99-7350	1	Decal-Rating, Hitch (Light Duty)
8:3	87-1450	2	Bushing-Flange	22	3234-24	4	Screw-HHF
9	302-5	2	Fitting-Grease	23	99-7654-03	1	Hitch-Duty, Light
11	328-24	1	Screw-HH	24	94-1402	1	Plug-Hole
12	114-8314	1	RH A-Arm ASM	25	3290-379	15	Tie-Cable
12:2	3-0348	2	Bushing	27	107-0252	1	Pad-Battery
12:3	87-1450	2	Bushing-Flange	28	107-0267	4	Isolator-Battery
14	112-3340-03	1	Front Frame ASM				

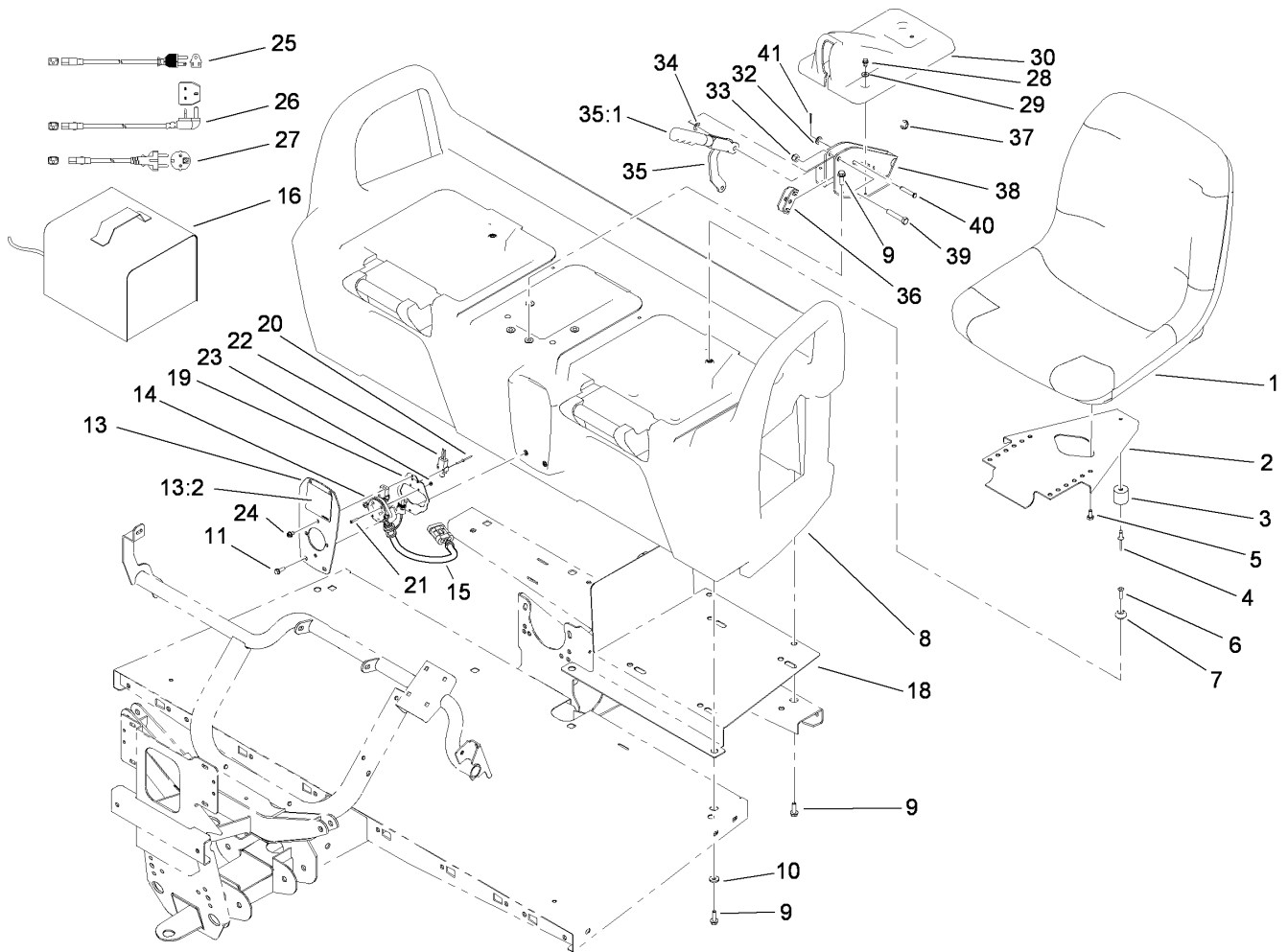

## Seat Base Assembly

<i>Ref.</i>	<i>Part Number</i>	<i>Qty.</i>	<i>Description</i>	<i>Ref.</i>	<i>Part Number</i>	<i>Qty.</i>	<i>Description</i>
1	112-2923	2	Seat ASM	22	99-3410	1	Switch
2	99-7829	2	Bracket-Seat	23	3296-9	2	Nut-Lock
3	99-7830	2	Rubber Receptical ASM	24	32104-17	4	Screw-HWH
4	3290-412	2	Rivet	25	107-0384	1	Powercord-Ac, Canada
5	33114-016	8	Screw-HH	26	107-0383	1	Powercord-Ac, U.K.
6	32108-5	2	Screw-FH	27	107-0382	1	Powercord-Ac, Europe
7	99-7833	2	Post-Holding	28	12-3270	2	Screw
8	104-6847	1	Seat Base ASM	29	3256-1	2	Washer-Flat
9	3234-17	12	Screw-HHF	30	104-7014	1	Cover-Brake, Parking
10	88-7200	8	Washer-Flat	32	3256-23	1	Washer-Flat
11	32105-15	4	Screw	33	3296-39	1	Nut-Lock, NI
13	107-0370	1	Plate-Receptacle	34	3290-477	1	Washer-Curved
13:2	107-0295	1	Decal-Charger	35	104-6842	1	Lever-Brake, Park
14	107-0288	1	Receptacle-Charger	35:1	106-7972	1	Grip-Handle
15	115-1913	1	Harness-Wire, Charger	36	87-3480	1	Bracket-Equalizer, Cable
16	112-2914	1	Charger-48V, Offboard	37	32120-47	2	Ring-Retaining, External
18	107-0359-03	1	Tray-Seatbase	38	104-6844-03	1	Support-Brake, Park
19	107-0716	1	Bracket-Mount, Socket	39	323-10	1	Screw-HH
20	107-0333	2	Rivet-Pop	40	94-3829	1	Pin-Clevis
21	107-0334	2	Screw-HSH	41	3272-6	1	Pin-Cotter

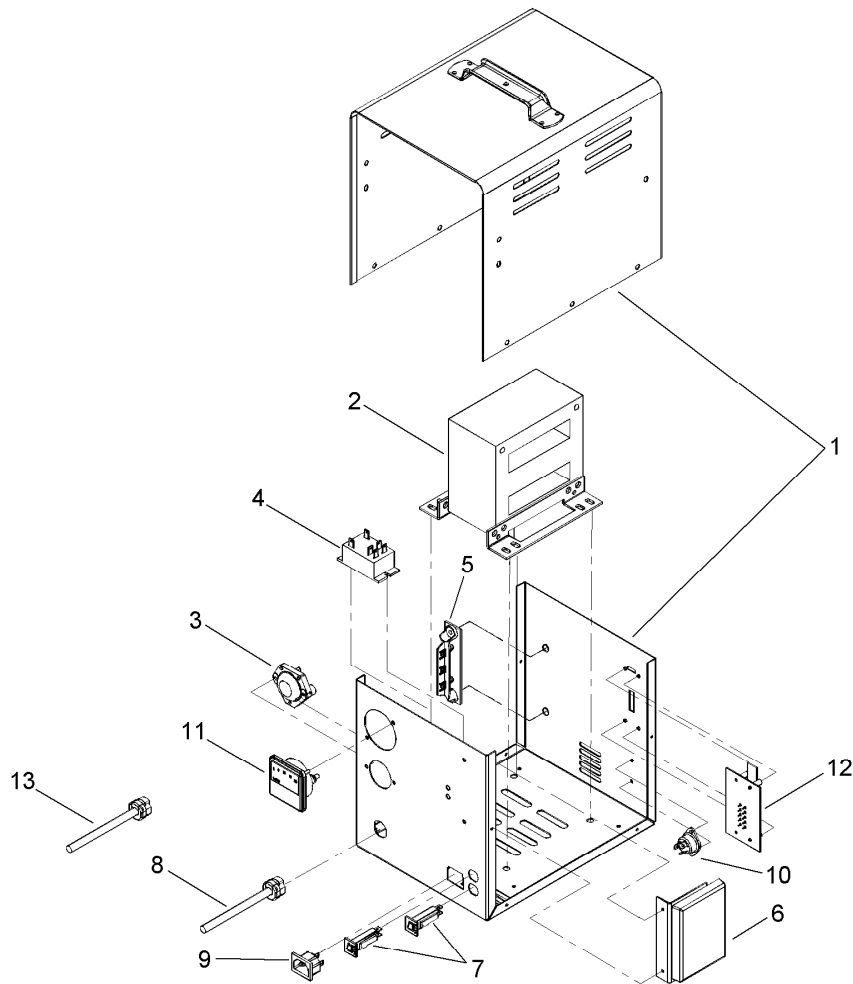

## Offboard 48 Volt Charger Assembly No. 112-2914

<i>Ref.</i>	<i>Part Number</i>	<i>Qty.</i>	<i>Description</i>
1		1	Case ASM ●
2		1	Transformer ASM ●
3	108-1161	1	Fuse ASM
4	108-1170	1	Relay, 48V Dc
5	108-1163	1	Diode ASM
6	112-2913	1	Control Board ASM
7	110-2577	2	Breaker-Circuit
8	108-1173	1	Kit-Cordset
9	108-1174	1	Connector-Inlet
10	108-1168	1	Terminal And Screw ASM
11	108-1175	1	Ammeter
12	110-2578	1	Switch ASM
13	108-3071	1	Kit-Cordset, 20 Foot (Dc)

● Not serviced separately

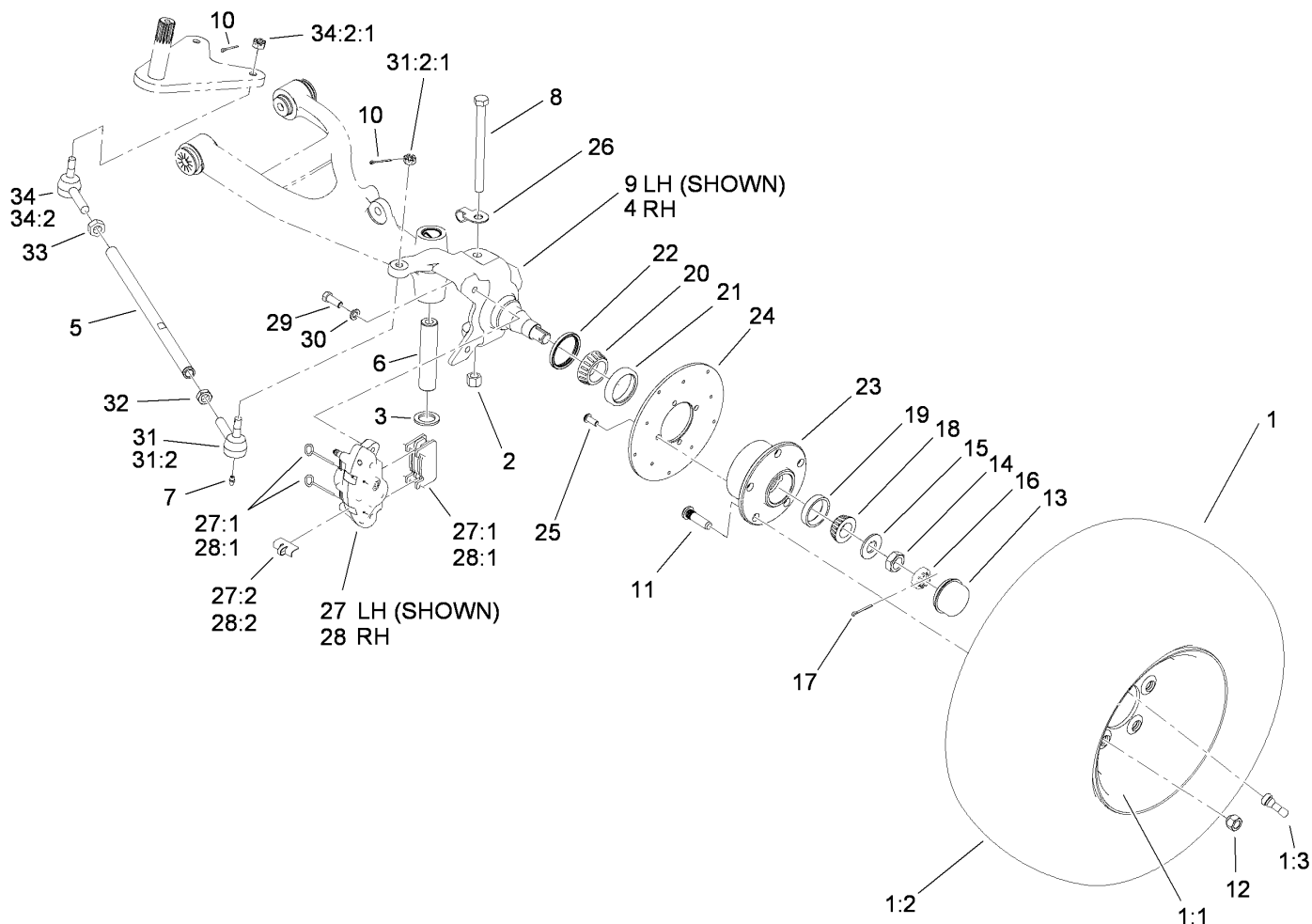

## Front Tire, Spindle and Tie Rod Assembly

Ref.	Part Number	Qty.	Description	Ref.	Part Number	Qty.	Description
1	104-7290	2	Tire And Wheel ASM	21	254-107	2	Cup-Bearing, Tapered
1:1	104-7288	1	Wheel	22	108-7019	2	Seal-Shaft
1:2	104-7289	1	Tire	23	104-6809	2	Hub
1:3	232-27	1	Stem-Valve	24	104-6891	2	Rotor
2	3296-23	2	Nut-Lock, NI	25	3274-55	8	Screw-HSBH
3	256-115	2	Washer-Thrust	26	112-3311	2	Clip-Hose
4	112-3167	1	Spindle-RH	27	112-3150	1	Caliper-LH
5	115-7654	2	Tie Rod	27:1	107-0708	1	Friction Pad And Pin Kit
6	99-7499	2	Sleeve-Kingpin	27:2	112-3152	1	Spring-Rattle, Anti
7	302-5	4	Fitting-Grease	28	112-3151	1	Caliper-RH
8	325-20	2	Screw-HH	28:1	107-0708	1	Friction Pad And Pin Kit
9	112-3166	1	Spindle-LH	28:2	112-3152	1	Spring-Rattle, Anti
10	3272-7	4	Pin-Cotter	29	323-6	4	Screw-HH
11	10-6830	10	Stud-Type, Drive	30	3253-21	4	Washer-Lock
12	242-50	10	Nut-Lug	31	112771-03	2	LH Ball Joint ASM
13	241-119	2	Cap-Dust	31:2		1	Joint-Ball, LH ●
14	3220-7	2	Nut-Jam	31:2:1	915031	1	Nut
15	93-0309	2	Washer-Tab	32	3218-21	2	Nut-Jam
16	93-0307	2	Nut-Lock, Retainer	33	3220-11	2	Nut-Jam
17	3272-12	2	Pin-Cotter	34	112772-03	2	RH Ball Joint ASM
18	254-94	2	Bearing-Cone, Tapered	34:2		1	Joint-Ball, RH ●
19	254-72	2	Bearing-Cup, Tapered	34:2:1	915031	1	Nut
20	254-106	2	Cone-Bearing, Tapered				

● Not serviced separately

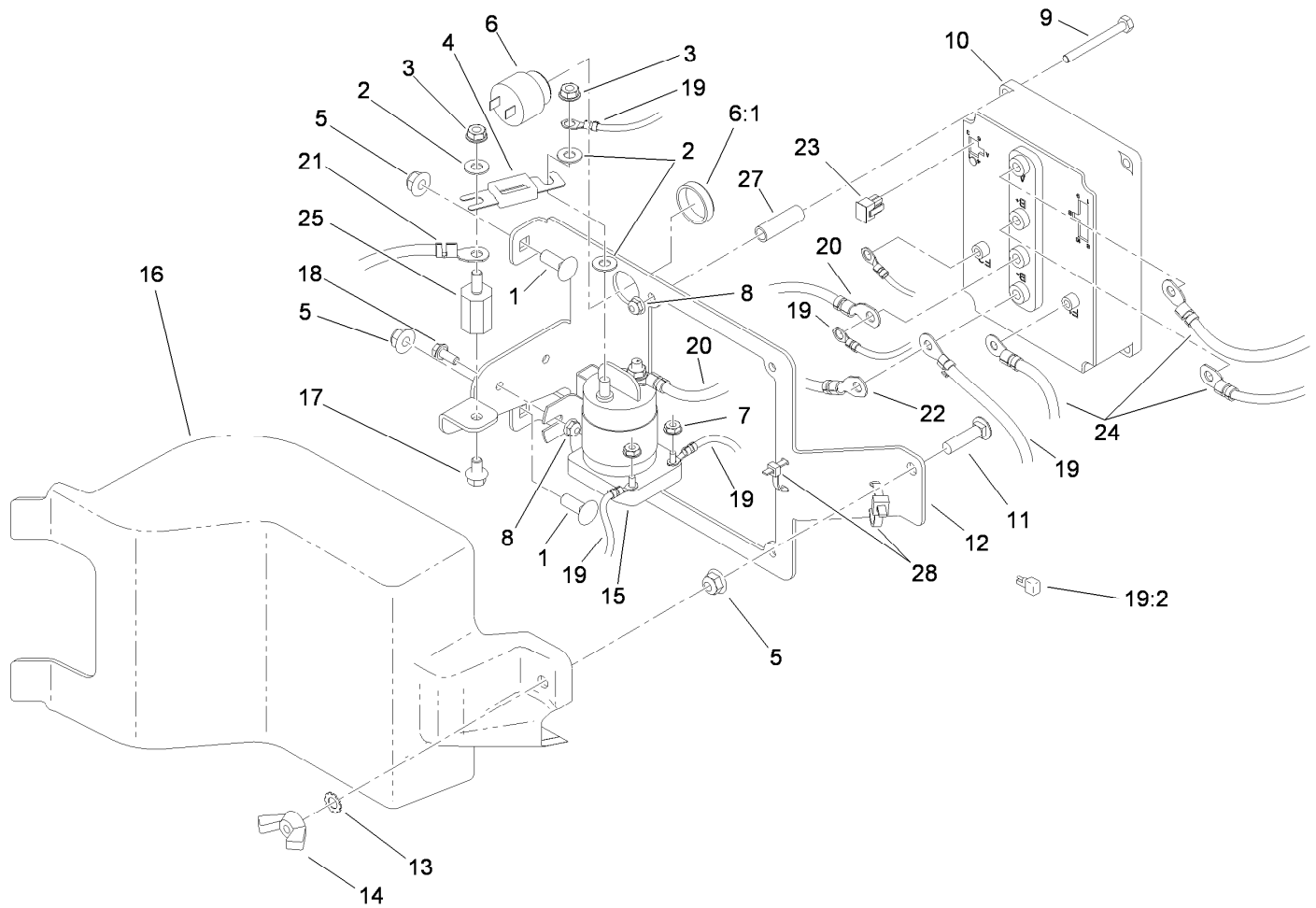

## Controller Assembly

<i>Ref.</i>	<i>Part Number</i>	<i>Qty.</i>	<i>Description</i>	<i>Ref.</i>	<i>Part Number</i>	<i>Qty.</i>	<i>Description</i>
1	3231-22	2	Screw-CARR	16	104-7138	1	Cover-Controller
2	107-0394	3	Washer-Flat	17	100-1719	1	Screw-Flange
3	107-0380	3	Nut-HHF	18	3234-33	2	Screw-HHF
4	104-7320	1	Fuse	19	117-4700	1	Harness-Wire, Mid Duty Elect
5	104-8301	3	Nut-Flange, NI	19:2	100-4918	1	Diode
6	94-5582	1	Alarm-Audio	20	107-0740	1	Cable-Battery, Positive
6:1	104-5107	1	Nut-Plastic, Knurled	21	107-0741	1	Cable-Battery, Positive
7	32149-8	2	Nut-Keps	22	107-0742	1	Cable-Battery, Negative
8	104-7201	6	Nut-HF	23	32160-130	1	Connector
9	321-15	4	Screw-HH	24	107-0737	1	Harness-Wire, Battery Cable
10	110-2569	1	Controller-Sevcon	25	107-0286	1	Isolator
11	3231-4	1	Screw-CARR	27	107-0285	4	Spacer
12	104-7137-03	1	Mount-Controller	28	3290-379	2	Tie-Cable
13	3255-9	1	Washer-Lock				
14	32103-3	1	Nut-Wing				
15	104-7136	1	Contactora-48V				

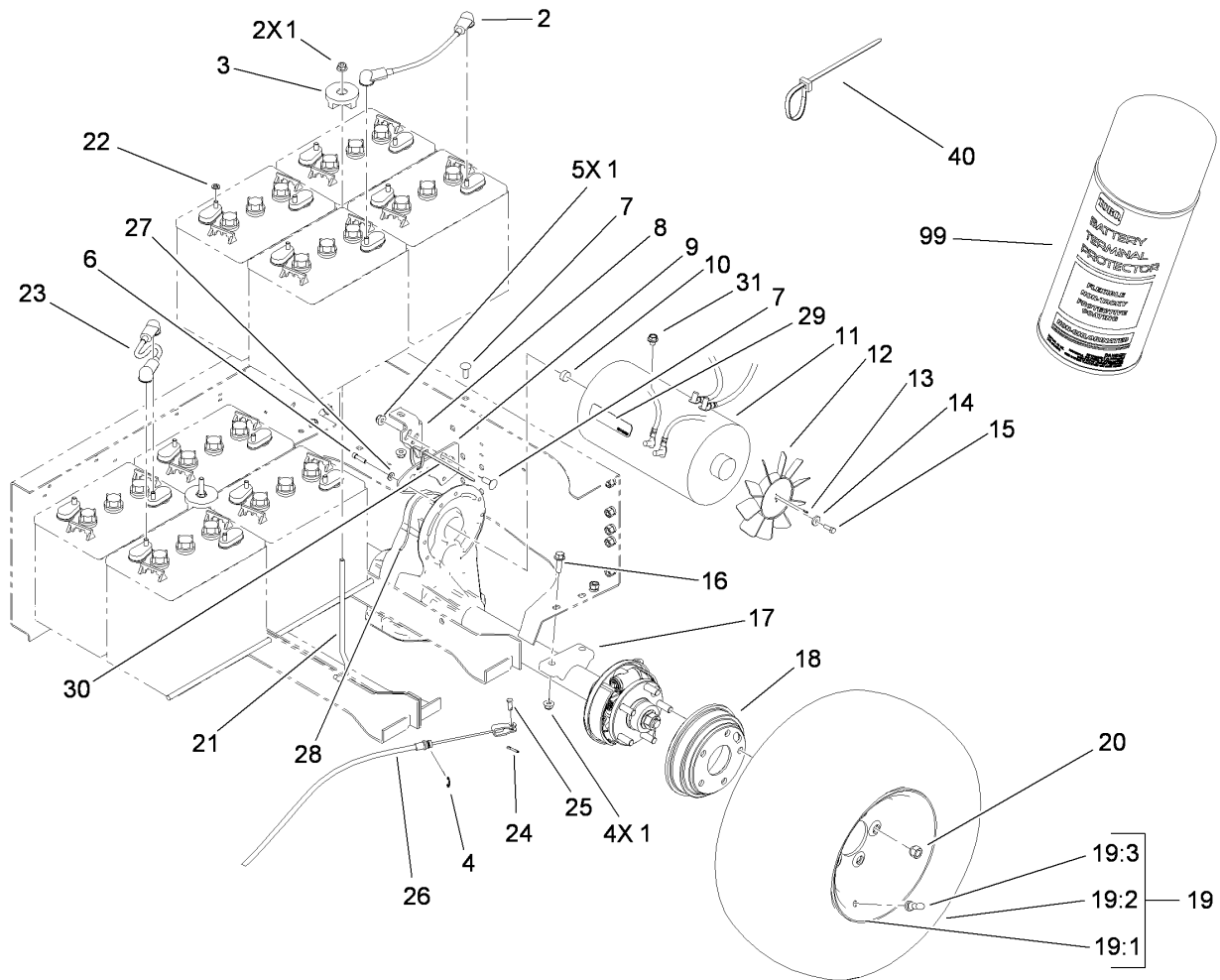

## Battery and Transaxle Assembly

Ref.	Part Number	Qty.	Description	Ref.	Part Number	Qty.	Description
1	104-8301	11	Nut-Flange, NI	19:1	104-7288	1	Wheel
2	107-0739	1	Cable-Battery, Positive	19:2	104-7289	1	Tire
3	104-7149	2	Hold Down ASM	19:3	232-27	1	Stem-Valve
4	32120-47	2	Ring-Retaining, External	20	242-50	10	Nut-Lug
6	3274-26	6	Screw-HSH	21	104-7339	2	Rod-Battery
7	3231-22	5	Screw-CARR	22	107-0280	16	Washer-Lock
8	104-7249-03	1	Bracket-Support	23	107-0738	6	Cable-Battery, Positive
9	104-7305-03	1	Plate-Mount, Transaxle	24	3272-10	2	Pin-Cotter
10	112-3399	1	Damper-Rubber	25	283-62	2	Pin-Clevis
11	104-7335	1	Motor-Electric	26	110-2647	2	Cable-Brake, Park
12	107-0259	1	Fan-10 Blade, Clockwise	27	3256-22	6	Washer-Flat
13	32121-68	2	Pin-Roll	28	110-1872	1	Hose-Fuel
14	73-3580	1	Washer	29	107-0356	1	Decal-Motor
15	3274-8	1	Screw-HSH	30	3290-379	12	Tie-Cable
16	3234-24	4	Screw-HHF	31	107-0376	1	Screw-HSFH
17	114-8330	1	Transaxle-Electric	40	3290-378	2	Tie-Cable
18	104-6500	2	Drum-Brake	99	107-0392	1	Protection-Terminal, Aerosol
19	104-7290	2	Tire And Wheel ASM				

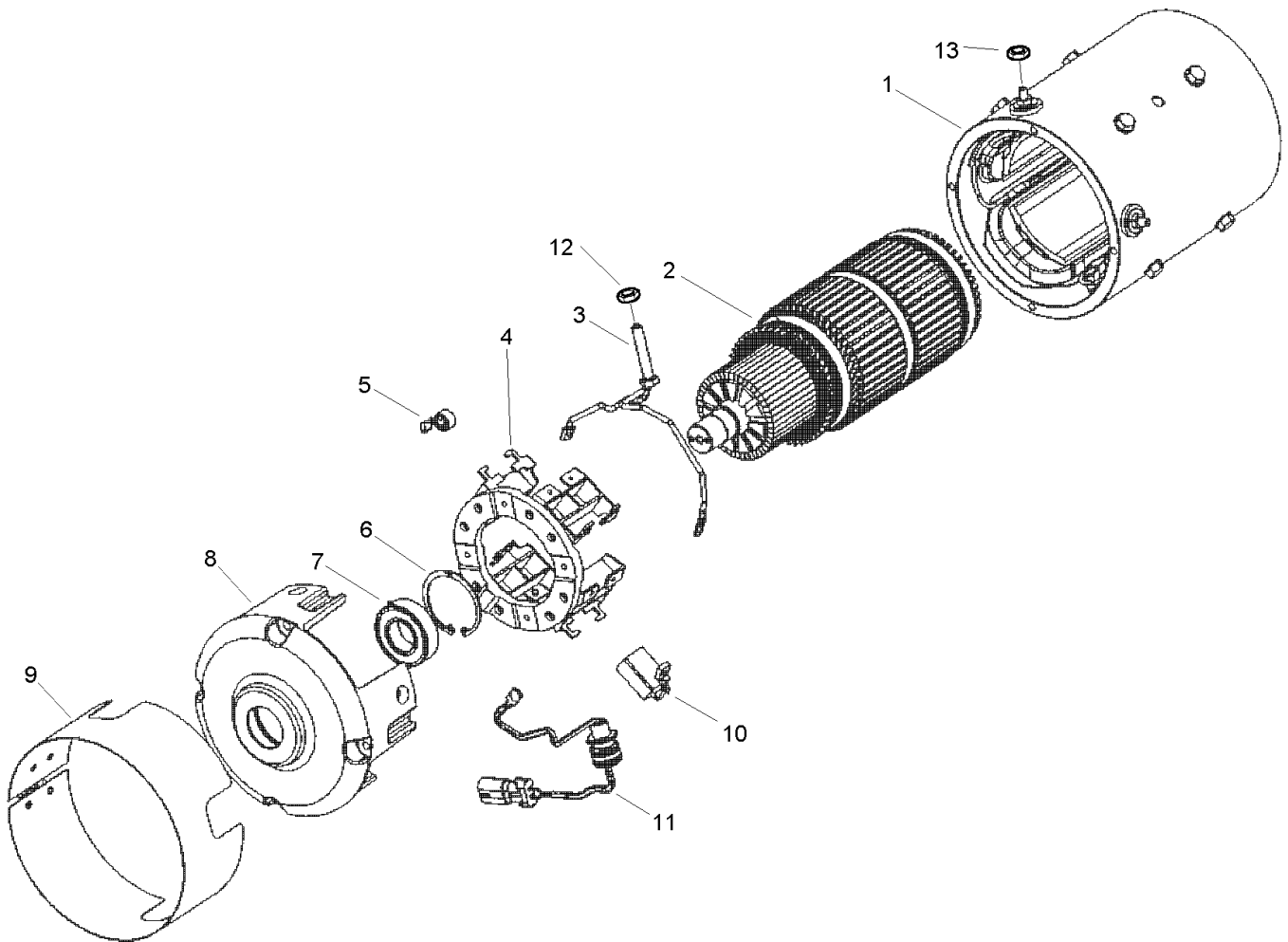

## Electric Motor Assembly No. 104-7335

<i>Ref.</i>	<i>Part Number</i>	<i>Qty.</i>	<i>Description</i>
1		1	Frame And Field ASM ●
2		1	Armature ASM ●
3	108-1151	2	Brush Lead ASM
4	108-1152	1	Brush Box ASM
5	108-1153	8	Spring-Brush
6	108-1154	1	Ring-Retaining
7	108-1155	1	Bearing
8	108-1156	1	Head-Commutator
9	108-1157	1	Headband ASM
10	108-1158	8	Brush
11	108-1159	1	Thermal Sensor ASM
12	3218-13	2	Nut-Jam, Brass
13	3218-14	2	Nut-Jam, Brass

● Not serviced separately

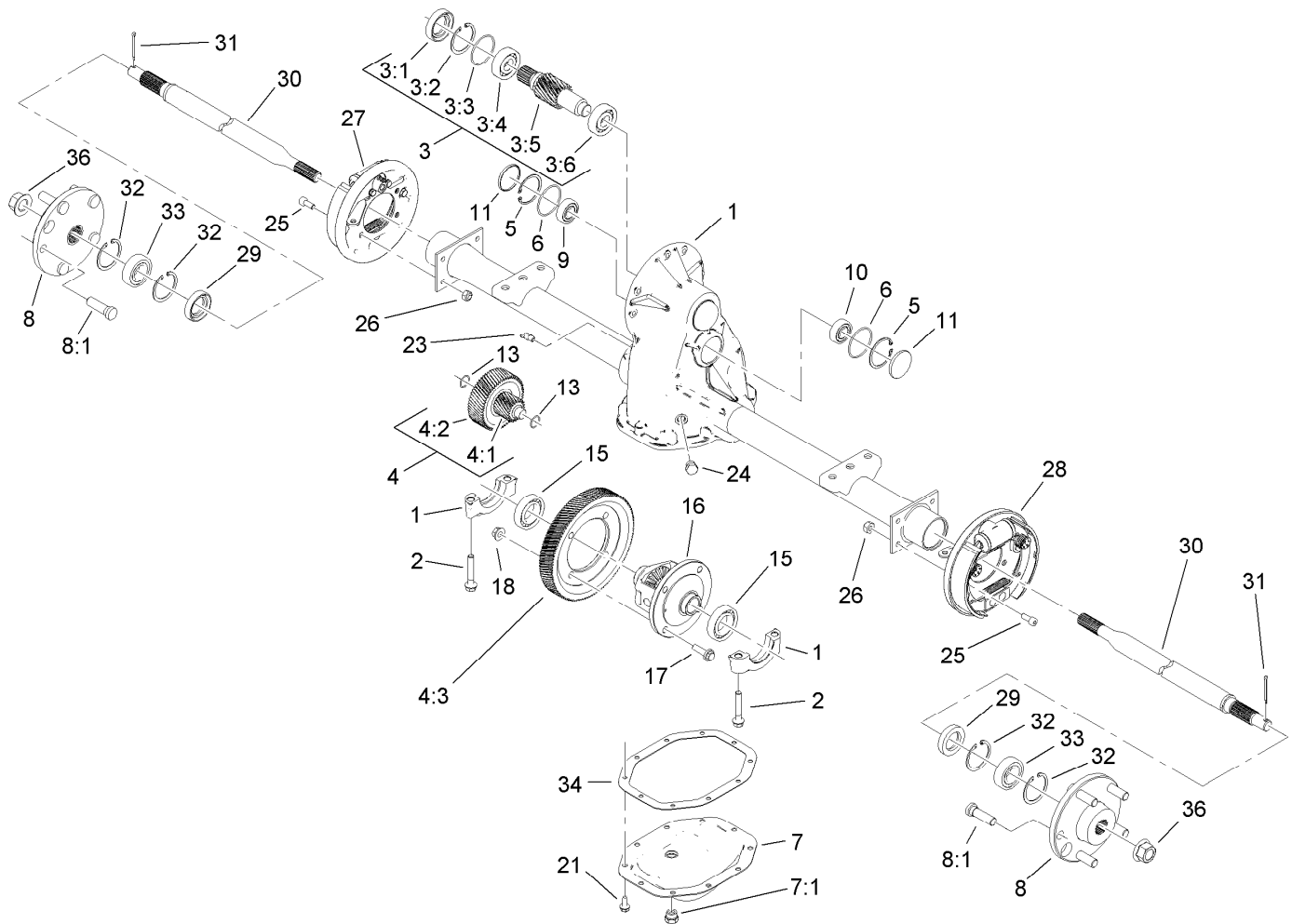

## Electric Transaxle Assembly No. 114-8330

Ref.	Part Number	Qty.	Description	Ref.	Part Number	Qty.	Description
1		1	Transaxle ASM ●	11	108-2408	2	Plug-Cap, End
2	108-2401	4	Bolt-Cap, Bearing	13	108-2410	2	O-Ring
3	115-2185	1	Input Shaft Kit	15	108-2411	2	Bearing-Ball
3:1	108-2403	1	Seal-Oil	16	112-3138	1	Differential ASM
3:2	108-2404	1	Ring-Retaining	17	108-2413	4	Screw-Hex
3:3	108-2405	1	O-Ring	18	108-2414	4	Nut-Lock
3:4		1	Bearing-Ball ●	21	108-2427	10	Screw-Tapping
3:5		1	Shaft-Input ●	23	108-2428	1	Elbow-90 Degree
3:6		1	Bearing-Ball ●	24	108-2429	1	Plug-HH
4	108-2409	1	Internal Gear Kit	25	112-3139	8	Screw-HSH
4:1		1	Shaft-Input ●	26	108-2418	8	Nut-Lock
4:2		1	Gear-Intermediate ●	27	114-8332	1	LH Brake ASM
4:3	110-2541	1	Gear-Drive, Final	28	114-8331	1	RH Brake ASM
5	108-2404	2	Ring-Retaining	29	112-3140	2	Seal-Oil
6	108-2405	2	O-Ring	30	112-3141	2	Shaft-Axle
7	108-2416	1	Cover Kit	31	3272-12	2	Pin-Cotter
7:1	108-2415	1	Plug-HH	32	108-2424	4	Ring-Retaining
8	112-3136	2	Hub ASM	33	108-2425	2	Bearing-Ball
8:1	112-3137	1	Bolt-Wheel	34	108-3148	1	Gasket
9	108-2406	1	Bearing-Ball	36	112-3142	2	Nut-HF
10	108-2407	1	Bearing-Ball				

● Not serviced separately

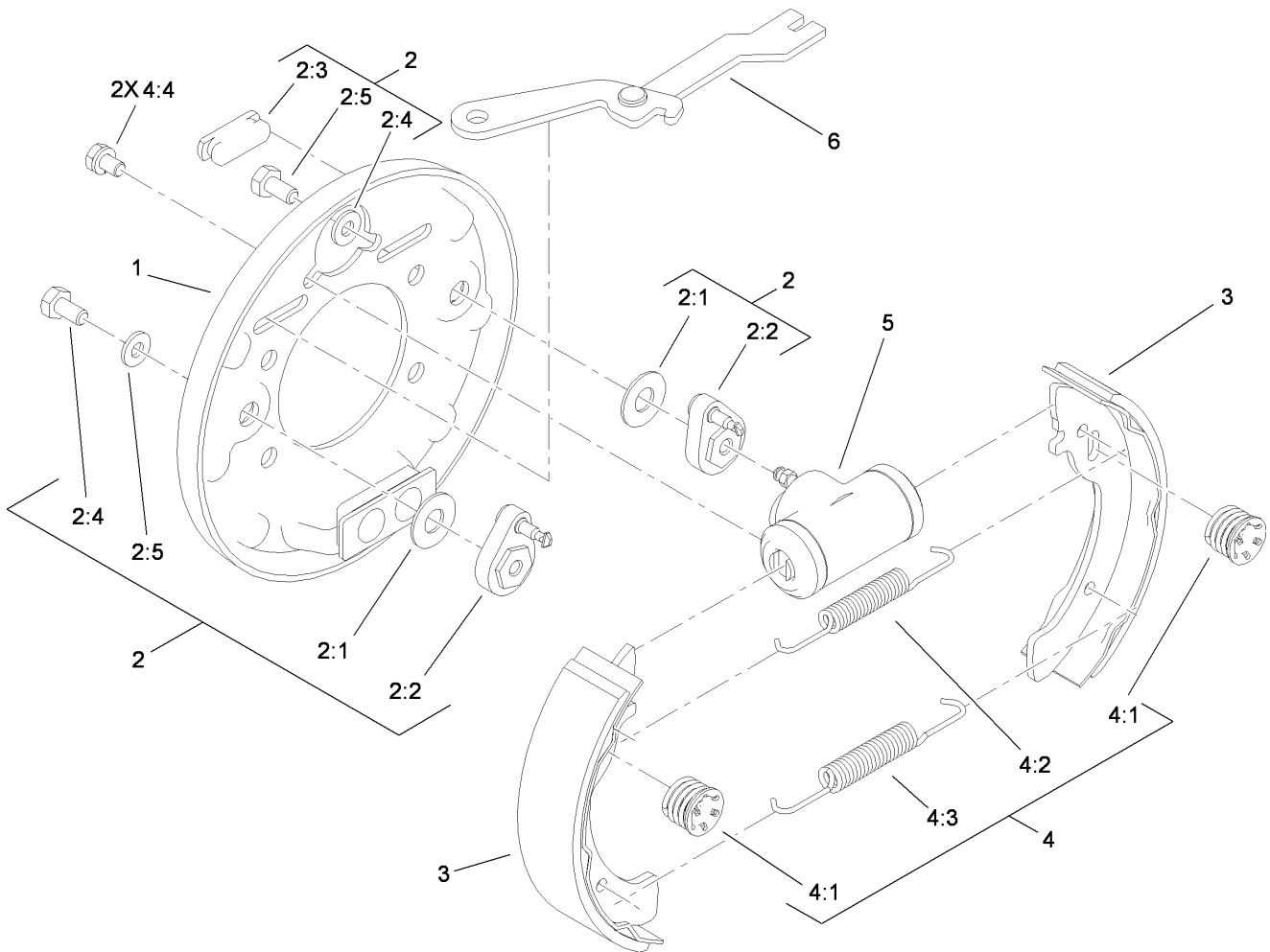

## LH Rear Brake Assembly No. 114-8332

Ref.	Part Number	Qty.	Description
1	100-8586	1	Backing Plate ASM
2	104-6820	1	Adjuster Kit
2:1	100-8585	2	Washer-Bellville
2:2	100-8588	2	Adjuster Lever ASM
2:3	100-8584	2	Cover-Dust
2:4		2	Washer ●
2:5		2	Bolt ●
3	104-6818	4	Shoe And Lining Kit
4	104-6819	1	Hardware Kit
4:1	100-8583	2	Shoe Hold Down Spring ASM
4:2	100-8581	2	Spring-Upper
4:3	100-8582	2	Spring-Lower
4:4		2	Bolt And Washer ●
5	114-8333	1	Wheel Cylinder ASM
6	104-6825	1	LH Park Brake Lever ASM

● Not serviced separately

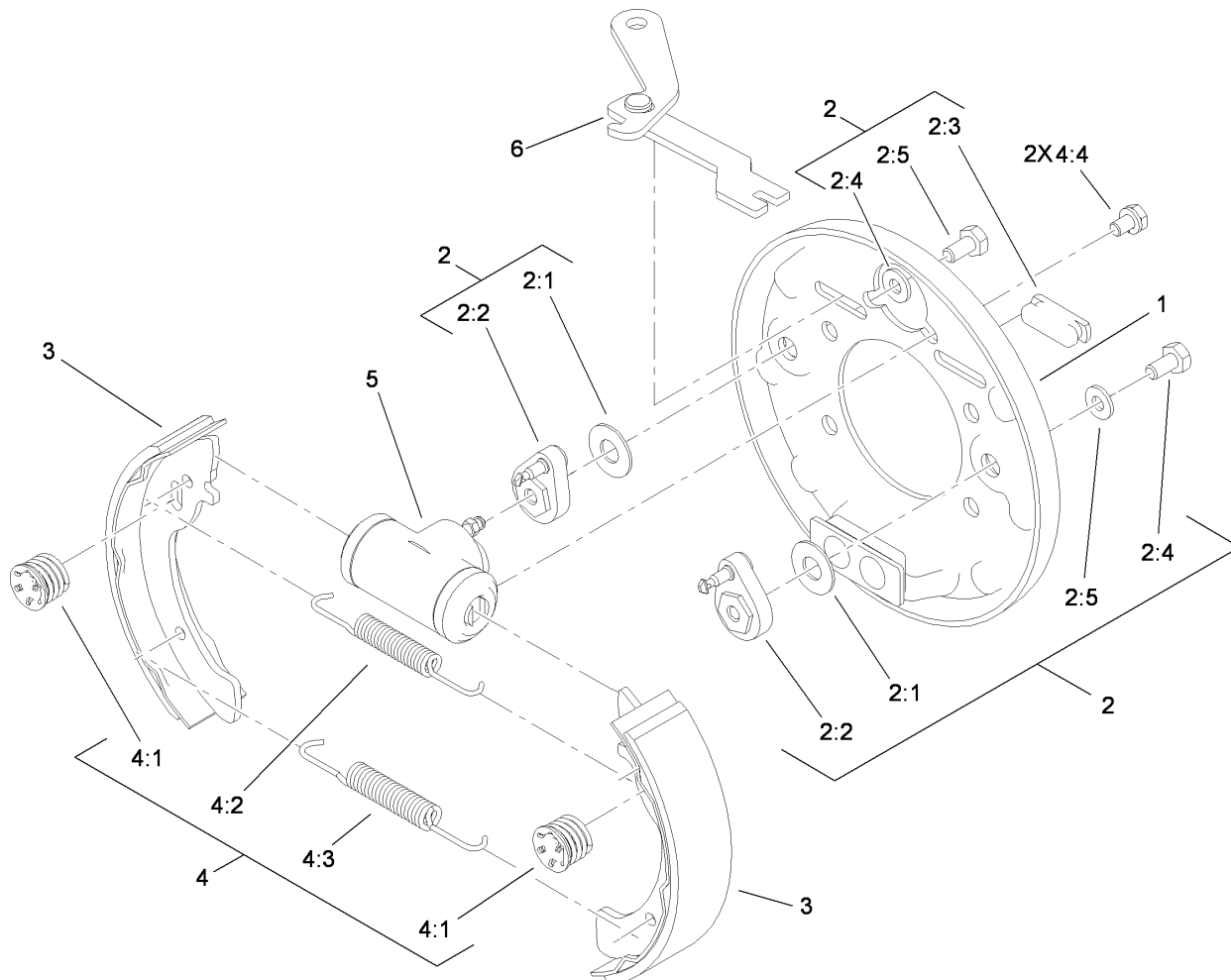

## RH Rear Brake Assembly No. 114-8331

Ref.	Part Number	Qty.	Description
1	100-8586	1	Backing Plate ASM
2	104-6820	1	Adjuster Kit
2:1	100-8585	2	Washer-Bellville
2:2	100-8588	2	Adjuster Lever ASM
2:3	100-8584	2	Cover-Dust
2:4		2	Washer ●
2:5		2	Bolt ●
3	104-6818	4	Shoe And Lining Kit
4	104-6819	1	Hardware Kit
4:1	100-8583	2	Shoe Hold Down Spring ASM
4:2	100-8581	2	Spring-Upper
4:3	100-8582	2	Spring-Lower
4:4		2	Bolt And Washer ●
5	114-8333	1	Wheel Cylinder ASM
6	104-6826	1	RH Park Brake Lever ASM

● Not serviced separately



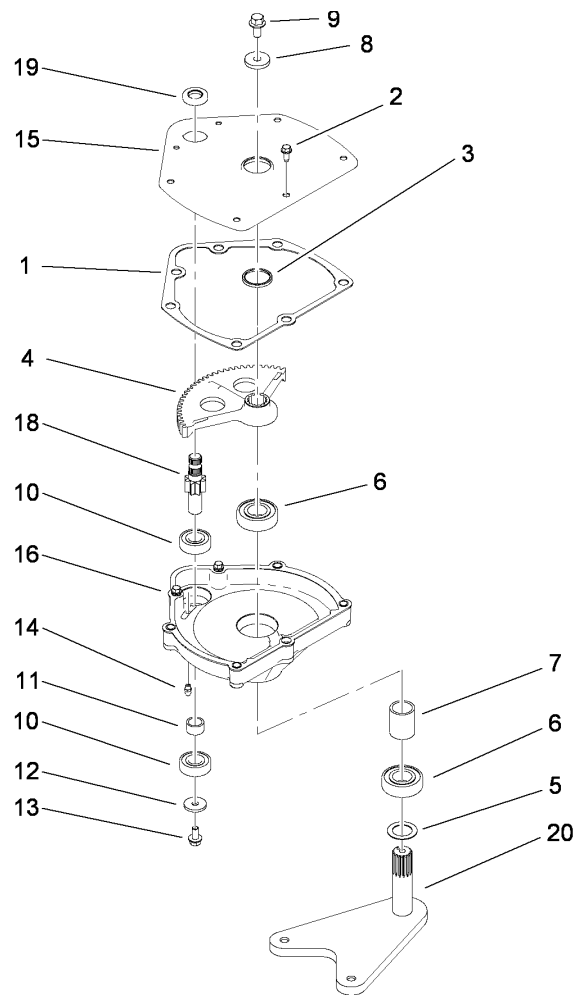

## Steering Box Assembly No. 112-3130

<i>Ref.</i>	<i>Part Number</i>	<i>Qty.</i>	<i>Description</i>
1	94-2135	1	Gasket
2	32144-10	3	Screw-HWH
3	103118	1	Seal
4	99-7843	1	Sector-Gear
5	3256-42	1	Washer-Flat
6	251-82	2	Bearing-Ball
7	112-2917	1	Spacer
8	104-6563	1	Washer-Stepped
9	104-7156	1	Screw-HHF
10	38-7820	2	Bearing-Ball
11	94-2217	1	Spacer-Shaft, Input
12	1-613235	1	Washer
13	98-3498	1	Screw-HH
14	302-5	1	Fitting-Grease
15	112-2918-03	1	Cover-Housing, Steering
16	114-8309	1	Housing-Steering
18	115-7726	1	Gear-Pinion
19	99-7657	1	Seal-Oil
20	112-3096-03	1	Pitman Arm ASM

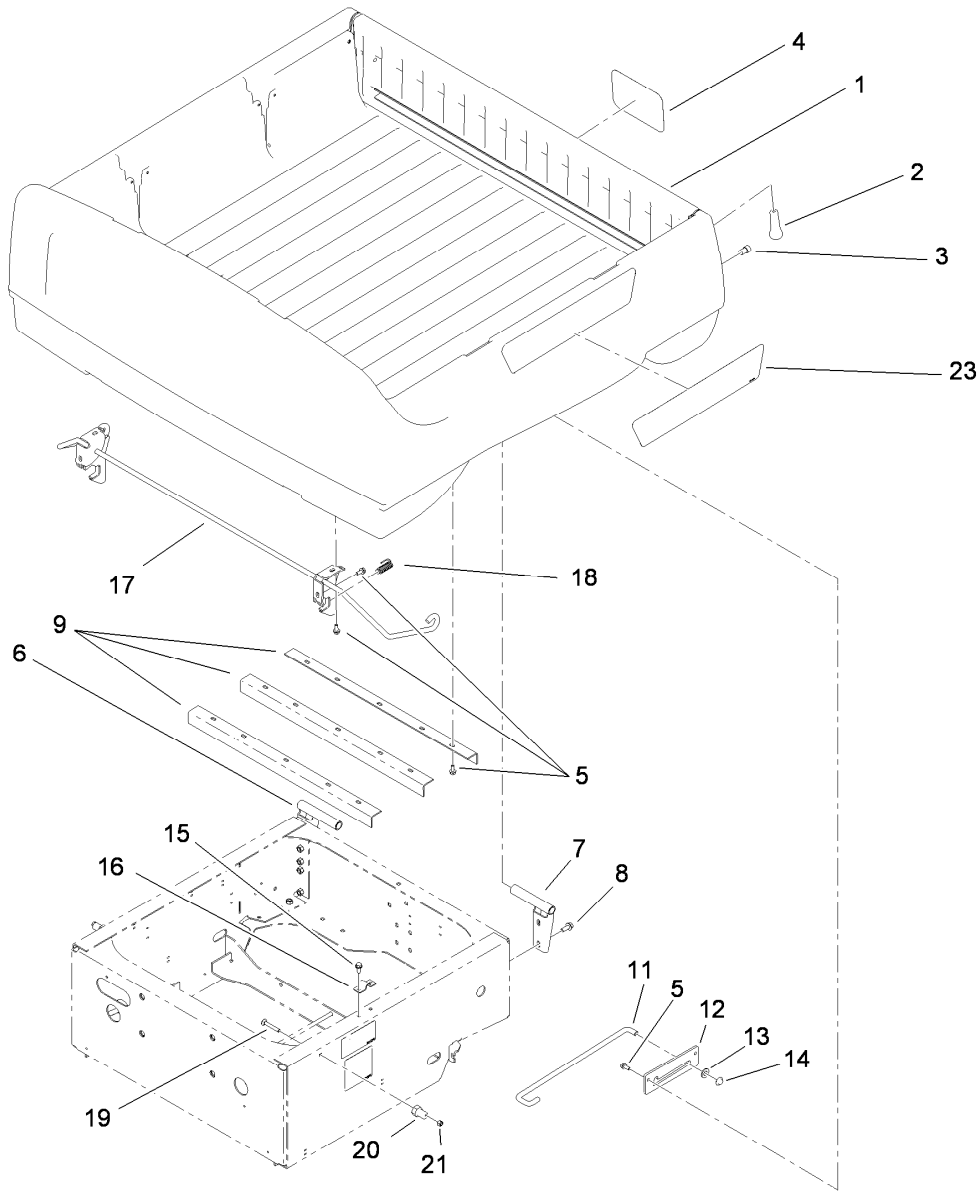

## Box and Tailgate Installation Assembly

Ref.	Part Number	Qty.	Description	Ref.	Part Number	Qty.	Description
1		1	Box And Tailgate ASM ●	13	3256-26	1	Washer-Flat
2	99-7984	2	Knob-Soft Grip, Push-On	14	32112-14	1	Nut-Push
3	115-7986	2	Bumper-Rubber	15	32104-32	2	Screw-HWH
4	104-7213	1	Decal	16	99-7896	1	Bracket-U, Prop Rod
5	3234-5	19	Screw-HHF	17	115-2385	1	Rod-Latch
6	99-7309-03	1	RH Pivot Bracket ASM	18	5-7290	2	Spring-Tension
7	99-7308-03	1	LH Pivot Bracket ASM	19	3230-7	2	Screw-CARR
8	105-6245	4	Screw-Tapping	20	104-7248	2	Pin-Latch
9	99-7864-03	3	Brace-Box	21	3296-29	2	Nut-Lock, NI
11	99-7895	1	Rod-Prop	23	115-2415	2	Decal
12	99-7894	1	Bracket-Rod, Prop				

● Not serviced separately

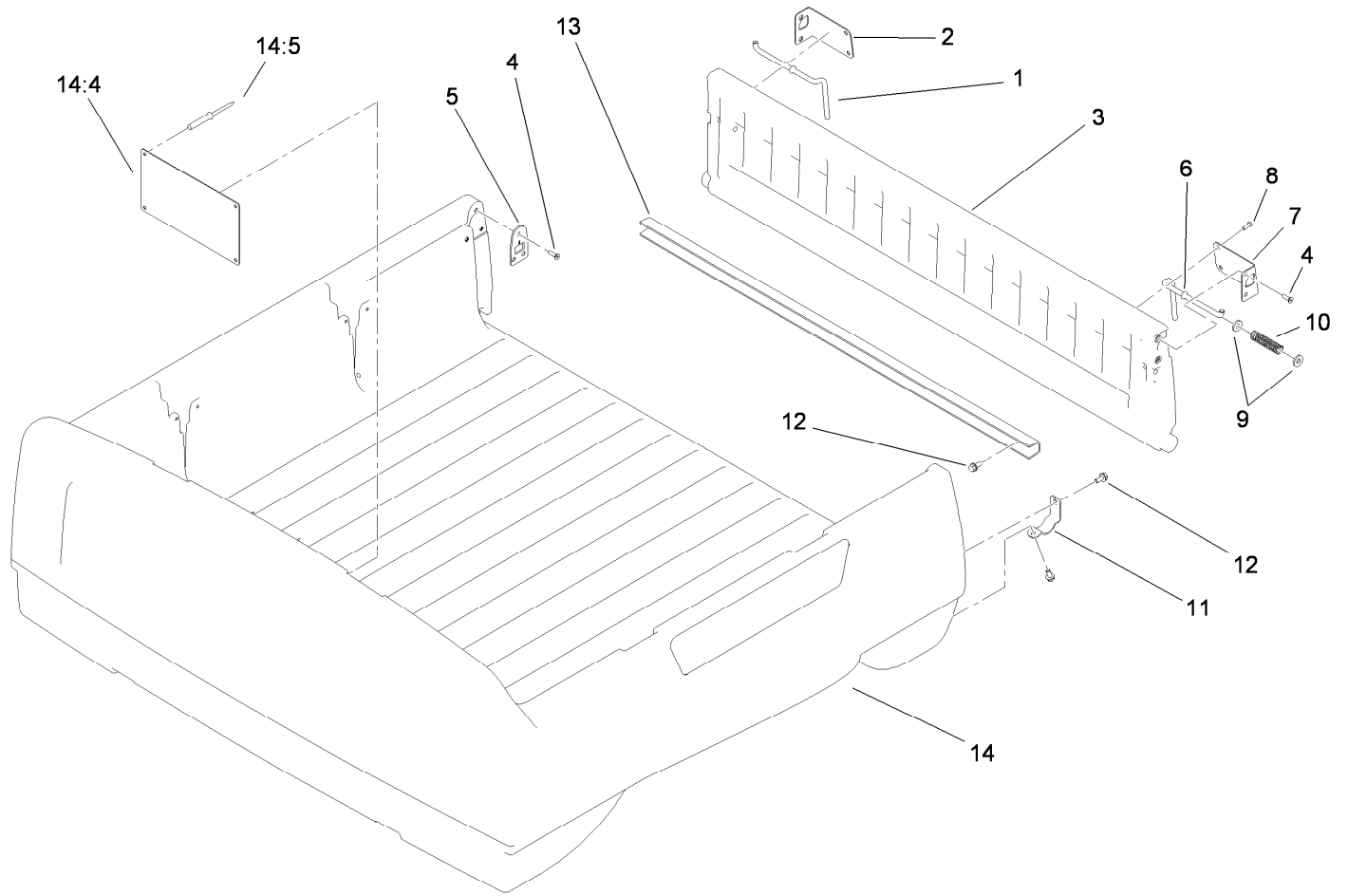

## Box and Tailgate Assembly

<i>Ref.</i>	<i>Part Number</i>	<i>Qty.</i>	<i>Description</i>	<i>Ref.</i>	<i>Part Number</i>	<i>Qty.</i>	<i>Description</i>
1	99-7860	1	Rod-Latch, Right	9	99-7861	4	Washer-Latch
2	99-7858	1	Bracket-Tailgate Latch, Right	10	61-8880	2	Spring
3	115-7640	1	Tailgate ASM	11	99-7286	2	Bracket-Pivot, Tailgate
4	99-7334	10	Screw	12	3234-5	10	Screw-HHF
5	114-2749	2	Striker Plate	13	99-7867	1	Channel-Tailgate
6	99-7859	1	Rod-Latch, Left	14	115-7638	1	Box ASM
7	99-7857	1	Bracket-Tailgate Latch, Left	14:4	99-7954	1	Decal-No Riders
8	99-7335	4	Screw	14:5	3290-415	4	Rivet

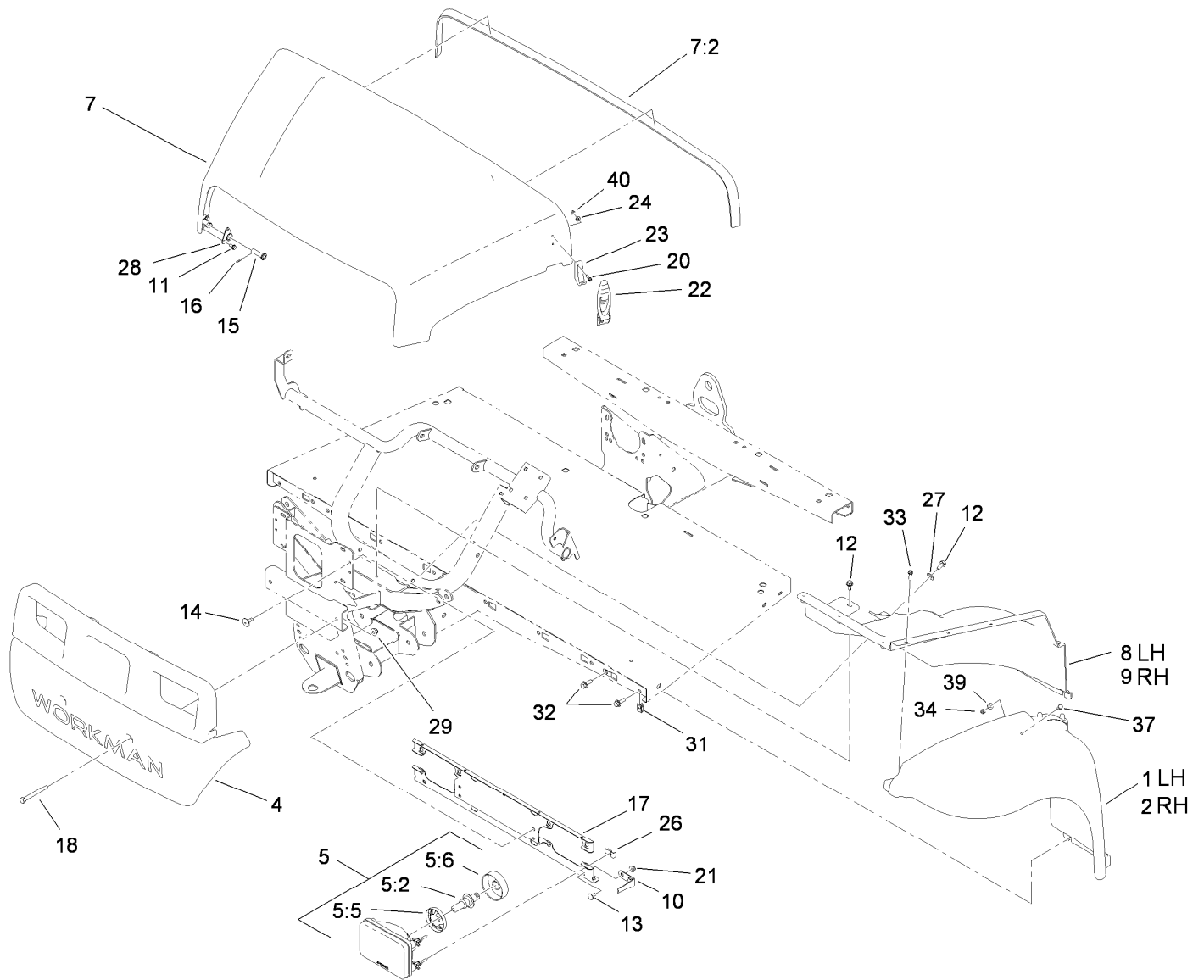

## Hood and Fender Assembly

Ref.	Part Number	Qty.	Description	Ref.	Part Number	Qty.	Description
1	112-3371	1	Fender-LH	17	119-0841-03	1	Bracket-Headlight
2	112-3370	1	Fender-RH	18	115-7660	2	Screw-HHF
4	112-3365	1	Bumper	20	32105-13	4	Screw-HWH
5	115-7617	2	Headlight ASM	21	32128-20	2	Nut-HF
5:2	115-7618	1	Bulb-24V	22	115-2416	2	Latch-Rubber
5:5	115-7667	1	Retainer-Headlight	23	103-2897	2	Latch-Catch
5:6	115-7668	1	Boot-Headlight	24	3256-14	4	Washer-Flat
7	115-7636	1	Hood ASM	26	115-2408	6	Clip-Speed
7:2	115-7635	1	Seal-Foam	27	3256-71	2	Washer-Flat
8	112-3369	1	Well-Fender, LH	28	112-3308	2	Retainer-Pin
9	112-3368	1	Well-Fender, RH	29	104-8301	2	Nut-Flange, NI
10	112-3373	2	Keeper-Pivot, Hood	31	112-3306	10	Nut
11	46-8093	6	Screw-Plastite	32	3234-29	10	Screw-HHF
12	32104-32	4	Screw-HWH	33	46-8091	20	Screw-HWH
13	3230-18	2	Screw-CARR	34	3296-42	2	Nut-Lock, NI
14	146489	4	Rivet	37	321-39	2	Screw-HH
15	117-5094	2	Pin-Clevis	39	3256-22	2	Washer-Flat
16	32121-50	2	Pin-Spring	40	3296-2	4	Nut-Lock, NI

# Attachments and Accessories

## For 07299TC Workman MDE Utility Vehicle

<b>Product Name</b>	<b>Model/Part</b>
Rear Lift Kit .....	07261
Electric Bed Lift Kit .....	07263
Roll-Over Protection System .....	07276
Receiver Hitch Kit .....	07278
Stake Side Kit .....	07290
Portable Refreshment Center .....	07298
12V Power Plug Adapter Kit .....	07318
Canopy Kit .....	07324
Solid Windshield Kit .....	07325
Folding Windshield Kit .....	07326
Snow Plow .....	07327
Hard Cab .....	07328
Heavy-Duty Bumper Kit .....	07329
Rear Lift Kit .....	07334
Vinyl Enclosure .....	07337
Heavy-Duty Brush Guard and Bumper Kit .....	07338
Sliding Window Door Kit .....	07352
Fixed Window Door Kit .....	07353
Wheel-5 Bolt .....	104-6889
Tire-AT 489, 24x10.5-10 .....	104-7061
Tire-AT 489, 22x9.5-10 .....	104-7062
Brake and Signal Light Kit .....	107-8020
20 foot Cordset Kit (DC) .....	108-3071
Brake and Signal Light Kit .....	115-7749
48V Battery Charger .....	115-7785
Lift Wire Harness Kit .....	115-7823
Replacement Front Spring Kit .....	117-4847
Potentiometer Kit .....	117-5085
Cord-AC (US/CANADA) .....	119-0661
Cord-AC (UK) .....	119-0662
Cord-AC (Europe) .....	119-0663
Tire And Wheel Asm .....	119-0751

**Notes:**

**Notes:**

**Notes:**



**Count on it.**