



ULTRA VAC®

Lazer Z® and Lazer Z® AS Models

Setup Instructions

For Ultra Vac Serial Nos. 790,000 & Higher
(To fit Lazer Z (LZZ) and Lazer Z AS (LZAS) Units
Serial Nos. 790,000 & Higher)

Important: Due to the added weight of the Ultra Vac, it is important to ensure the parking brake on your mower is adjusted properly. Before installing the Ultra Vac, make sure to re-adjust the parking brake on your mower as outlined in the “Adjusting the Parking Brake” procedure in the Maintenance section of the tractor Operator’s manual.

Loose Parts

Use the chart below to verify that all parts have been shipped. Part numbers not shown are available on the dealer extranet.

| Dealer Pack | | | |
|-------------|--------------------------------|------|---|
| Part # | Description | Qty. | Use |
| — | Warranty Registration Reminder | | Fill out the online warranty registration form. |

| Literature Pack | | | |
|-----------------|--------------------|------|------------------------------------|
| Part # | Description | Qty. | Use |
| — | Manual, Operator’s | 1 | Read before operating the machine. |
| — | Manual, Parts | 1 | |

Models and Required Completing Kits

Completing Kits

Note: Use the following charts to verify the kits required for the unit you are installing the UltraVac on.

| | 48 Inch Deck | 52 Inch Deck | 60 Inch Deck | 72 Inch Deck |
|----------|--------------|--------------|--------------|--------------|
| Series 4 | 109-9622 | 109-9624 | 109-9626 | 109-9628 |
| Series 6 | 109-9623 | 109-9625 | 109-9627 | 109-9629 |

LZUVQD7 & LZUVQD11 Diagram

| Key | Qty | Description |
|-----|-----|--|
| 1 | 1 | Asm, Hopper |
| 2 | 1 | Mount, Pivot |
| 3 | 1 | Asm, Dump Handle |
| 4 | 1 | Asm, Handle Linkage |
| 5 | 1 | Pin, Clevis Spring |
| 6 | 1 | Pin, Cotter |
| 7 | 5 | Washer (LZUVQD11) |
| | 4 | Washer (LZUVQD7) |
| 8 | 12 | Bolt, Carriage 3/8-16 x 1 1/4 (LZUVQD11) |
| | 10 | Bolt, Carriage 3/8-16 x 1 1/4 (LZUVQD7) |
| 9 | 20 | Nut, Nyloc 3/8-16 Flg (LZUVQD11) |
| | 18 | Nut, Nyloc 3/8-16 Flg (LZUVQD7) |
| 10 | 1 | Asm, Blower |
| 11 | 1 | Asm, Lower Tube |
| 12 | 1 | Mount, Lower |
| 13 | 1 | Mount, Upper |
| 14 | 2 | Bolt, Carriage 1/2-13 x 2 1/2 |
| 15 | 1 | Diverter, Exhaust |
| 16 | 2 | Asm, Caster Weight (LZUVQD11) |
| 17 | 2 | Pin, Hair |
| 18 | 1 | Asm, Weight Mount Plate |
| 19 | 1 | Screw, HH 3/8-16 x 1 1/4 |
| 20 | 2 | Weight, Toeboard (LZUVQD11) |
| | 3 | Weight, Toeboard (LZUVQD7) |
| 21 | 4 | Pin, Hair (LZUVQD11) |
| | 6 | Pin, Hair (LZUVQD7) |
| 22 | 1 | Bracket, Belt Cover |
| 23 | 1 | Bolt, Carriage 5/16-18 x 1 |
| 24 | 1 | Ring, Bolt Retaining |
| 25 | 1 | Knob, 3-Prong |
| 26 | 1 | Plug, Nylon |
| 27 | 1 | Pin, Chute Pivot |
| 28 | 1 | Pin, Hair |
| 29 | 2 | Pin, Clevis |
| 30 | 1 | Asm, Reinforced Bumper RH |
| 31 | 1 | Washer, #10 Flat |
| 32 | 1 | Tube, Upper |

| Key | Qty | Description |
|-----|-----|---------------------------------------|
| 33 | 1 | Asm, Reinforced Bumper LH W/Decal |
| 34 | 1 | Cover, Belt |
| 35 | 1 | Belt |
| 36 | 1 | Sheave, Drive |
| 37 | 1 | Nut, #10 Nyloc |
| 38 | 1 | Screw, #10-24 CRPH |
| 39 | 2 | Nut, Lock 1/2-13 |
| 40 | 2 | Asm, Bagger Mount Pin |
| 41 | 4 | Nut, Whizlock 3/8-16 (LZUVQD11) |
| 42 | 4 | Bolt, Square Hd 3/8-16 x 4 (LZUVQD11) |
| 43 | 2 | Asm, Caster Weight Bracket (LZUVQD11) |

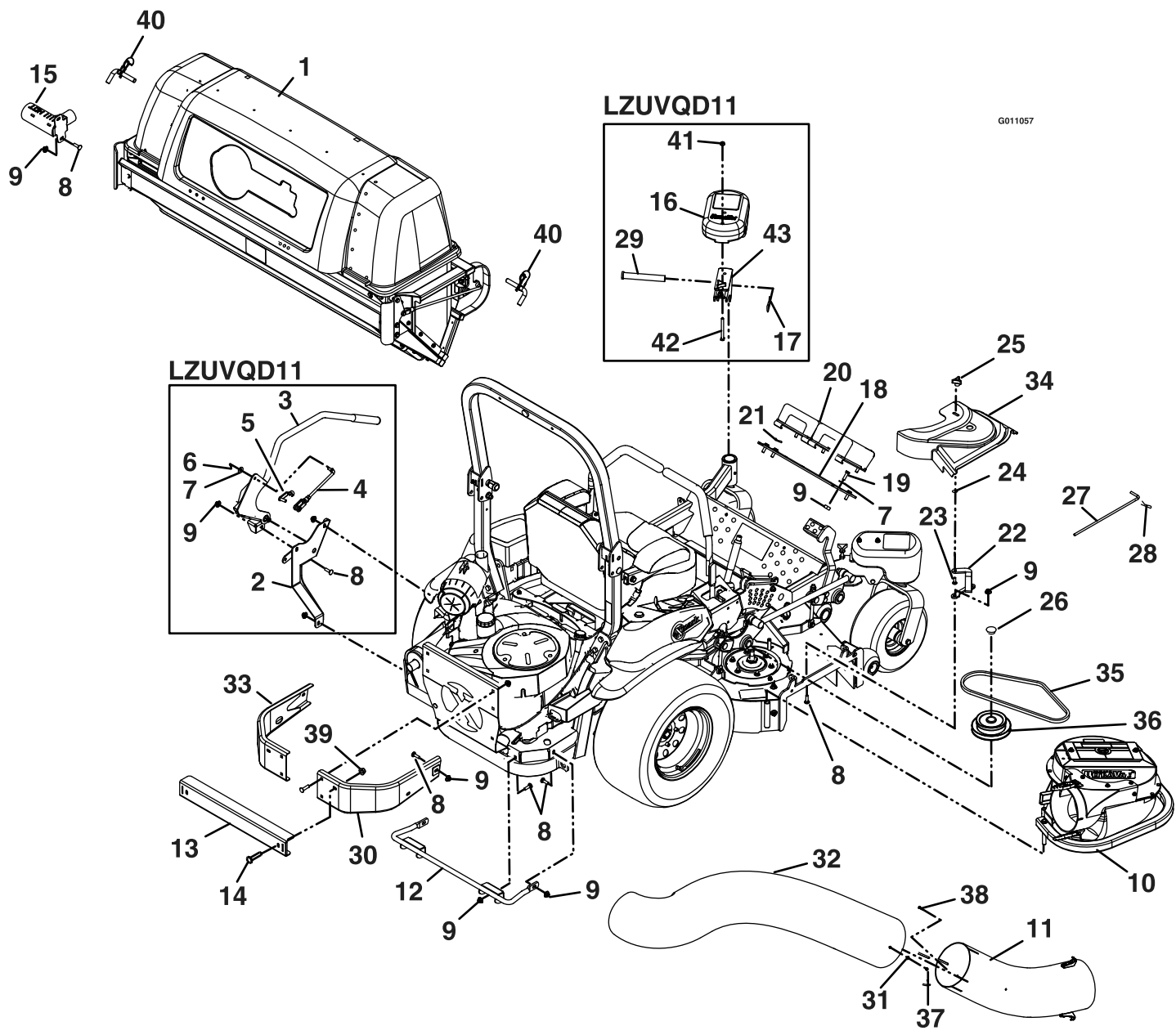

Figure 1

LZUV2B & LZUV3B Diagram

| Key | Qty | Description |
|-----|-----|---------------------------------------|
| 1 | 1 | Asm, Hood |
| 2 | 1 | Wld, Lower Mount |
| 3 | 10 | Bolt, Carriage 3/8-16 x 1 1/4 |
| 4 | 20 | Nut, Nyloc 3/8-16 Flg |
| 5 | 1 | Mount, Upper Bagger |
| 6 | 2 | Bolt, Carriage 3/8-16 x 2 1/2 |
| 7 | 3 | Asm, Bag & Frame (LZUV3B) |
| | 2 | Asm, Bag & Frame (LZUV2B) |
| 8 | 1 | Asm, Blower |
| 9 | 1 | Asm, Lower Tube |
| 10 | 1 | Diverter, Exhaust |
| 11 | 2 | Asm, Cast Weight (LZUV3B) |
| 12 | 2 | Pin, Clevis (LZUV3B) |
| 13 | 2 | Pin, Hair (LZUV3B) |
| 14 | 1 | Asm, Weight Mount Plate |
| 15 | 4 | Washer |
| 16 | 4 | Screw, HH 3/8-16 x 1 1/4 |
| 17 | 2 | Asm, Toe Board Weight (LZUV3B) |
| | 3 | Asm, Toe Board Weight (LZUV2B) |
| 18 | 4 | Pin, Hair |
| 19 | 1 | Bracket, Belt Cover |
| 20 | 1 | Bolt, Carriage 5/16-18 x 1 |
| 21 | 1 | Ring, Bolt Retaining |
| 22 | 1 | Knob, 3-Prong |
| 23 | 1 | Plug, Nylon |
| 24 | 1 | Pin, Chute Pivot |
| 25 | 1 | Pin, Hair |
| 26 | 1 | Wld, Reinforced Bumper RH |
| 27 | 1 | Asm, Reinforced Bumper LH W/Decal |
| 28 | 1 | Cover, Belt |
| 29 | 1 | Belt |
| 30 | 1 | Sheave, Drive |
| 31 | 1 | Nut, #10 Nyloc |
| 32 | 1 | Screw, #10-24 CRPH |
| 33 | 2 | Asm, Caster Weight Bracket (LZUVQD11) |
| 34 | 1 | Washer, #10 Flat |
| 35 | 1 | Tube, Upper |
| 36 | 2 | Nut, Lock 1/2-13 |

| Key | Qty | Description |
|-----|-----|---------------------------------------|
| 37 | 2 | Asm, Bagger Mount Pin |
| 38 | 4 | Nut, Whizlock 3/8-16 (LZUVQD11) |
| 39 | 4 | Bolt, Square Hd 3/8-16 x 4 (LZUVQD11) |

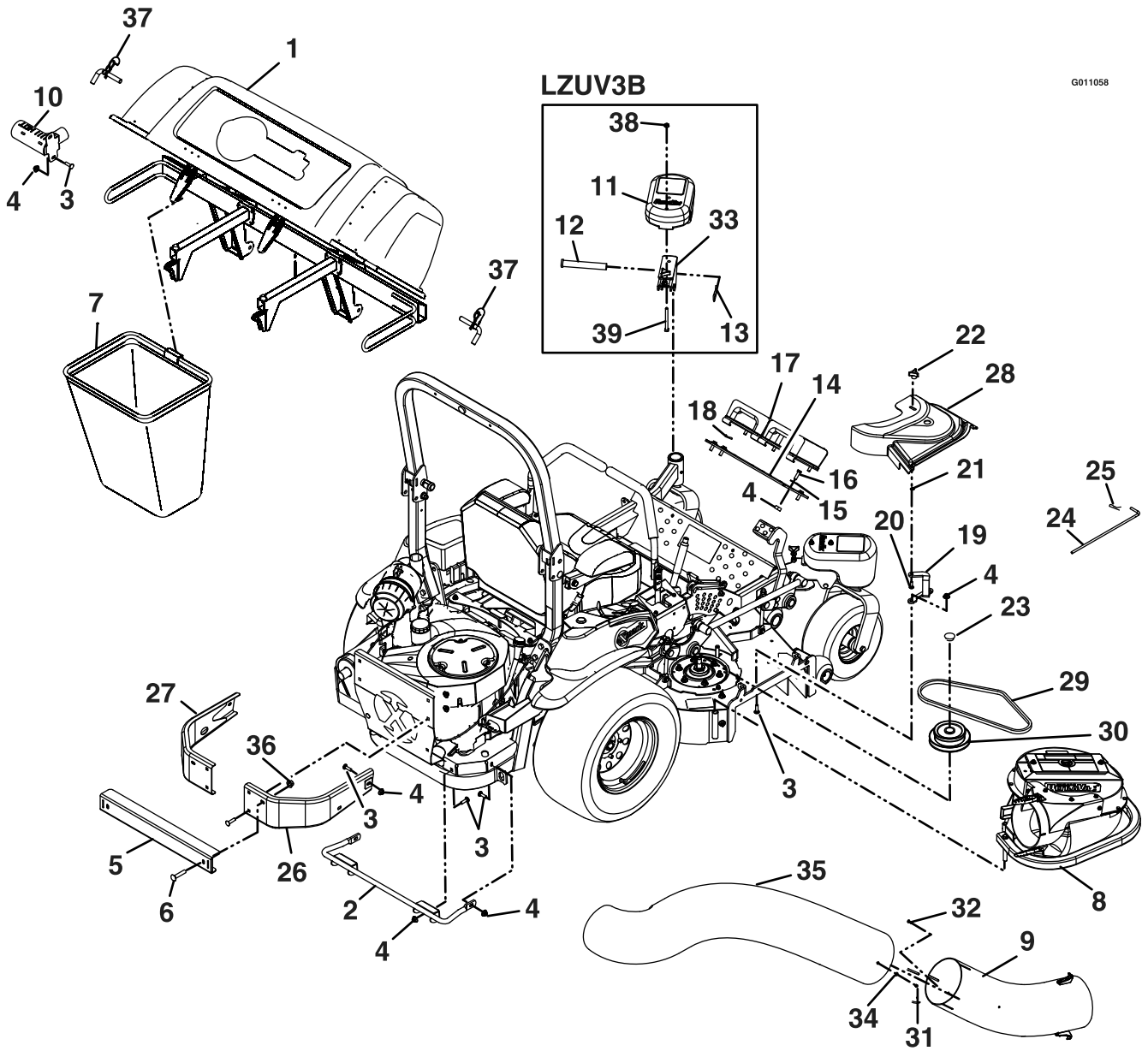

Figure 2

Safety

Safety Alert Symbol

This Safety Alert Symbol (Figure 3) is used both in this setup instructions and on the machine to identify important safety messages which must be followed to avoid accidents.

This symbol means: **ATTENTION! BECOME ALERT! YOUR SAFETY IS INVOLVED!**



Figure 3

1. Safety alert symbol

The safety alert symbol appears above information which alerts you to unsafe actions or situations and will be followed by the word **DANGER**, **WARNING**, or **CAUTION**.

DANGER: White lettering / Red background. Indicates an imminently hazardous situation which, if not avoided, **Will** result in death or serious injury.

WARNING: Black lettering / Orange background. Indicates a potentially hazardous situation which, if not avoided, **Could** result in death or serious injury.

CAUTION: Black lettering / Yellow background. Indicates a potentially hazardous situation which, if not avoided, **May** result in minor or moderate injury.

This manual uses two other words to highlight information. **Important** calls attention to special mechanical information and **Note** emphasizes general information worthy of special attention.

Adjusting the Parking Brake

Re-adjust the parking brake on your mower as outlined in the “Adjusting the Parking Brake” procedure in the Maintenance section of the tractor Operator’s manual.

Adjusting the Muffler Guard

The muffler guard needs to be repositioned to provided clearance when installing the Ultra Vac.

1. Stop engine, wait for all moving parts to stop, and remove the key. Allow the unit to cool completely.
2. Loosen all three nuts that secure the muffler guard to the mower frame.

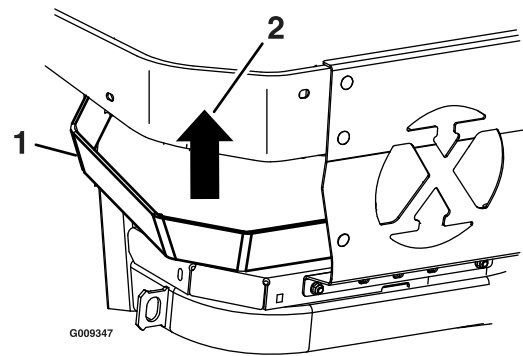

Figure 4

1. Muffler guard
2. Pull up

3. Pull up on the muffler guard as far as it will go and tighten the nuts.

Installing the Reinforced Rear Bumpers

1. Remove the rear bumpers and hardware from the mower. Retain the four 3/8-16 x 1 3/4 inch carriage bolts (item 1 in Figure 5).
2. Install the new reinforced LH and RH rear bumpers using the hardware shown in Figure 5.

Note: Prior to installing the LH bumper on LZUVQD11 unit, see **Installing the Dump Handle** instructions

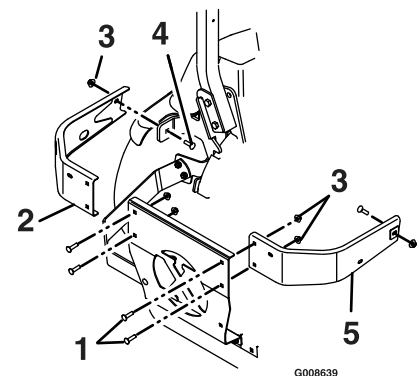

Figure 5

1. Existing hardware
2. LH rear bumper
3. 3/8-16 inch nyloc nut
4. 3/8-16 x 1 1/4 inch carriage bolt
5. RH rear bumper

Installing the Upper and Lower Mount Brackets

1. Mount the upper bracket to the left and right rear bumpers using 1/2-13 x 2 1/2 carriage bolts and 1/2-13 lock nuts (see Figure 6).

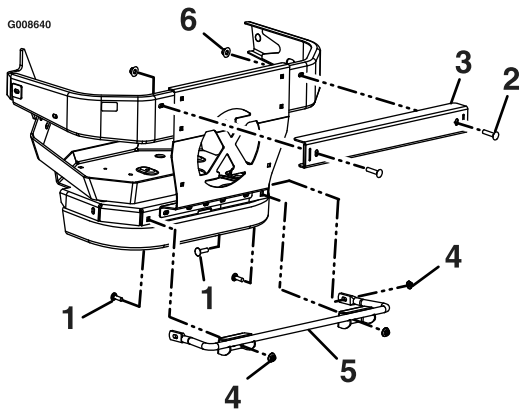

Figure 6

1. 3/8-16 x 1 1/4 inch carriage bolt
2. 1/2-13 x 2 1/2 inch carriage bolt
3. Upper bagger mount
4. 3/8-16 inch nyloc nut
5. Lower bagger mount
6. 1/2-13 inch lock nut

2. Install the lower mount bracket using four 3/8-16 x 1 1/4 inch carriage bolts and four 3/8-16 nyloc nuts.

Installing the Dump Handle (LZUVQD11 Only)

1. Mount the pivot mount to the LH rear bumper using two additional 3/8-16 x 1 1/4 inch carriage bolts and two 3/8-16 inch nyloc nuts as shown in Figure 7.

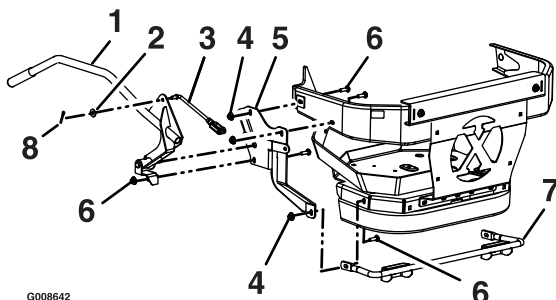

Figure 7

1. Dump handle
2. Washer
3. Handle link
4. 3/8-16 inch nyloc nut
5. Pivot mount
6. 3/8-16 x 1 1/4 inch carriage bolt
7. Lower bagger mount
8. Cotter pin

2. Secure the lower bagger mount to the frame and pivot mount, using 3/8-16 x 1 1/4 inch carriage bolt and 3/8-16 inch nyloc nut.
3. Insert the handle pin and dump handle assembly into the pivot mount hole as shown in Figure 7.

4. Using 3/8-16 x 1 1/4 inch carriage bolt and 3/8-16 inch nyloc nut, secure the handle pin to the pivot mount.
5. Insert the handle link into the mounting hole of the dump handle and install the washer and cotter pin.

Installing the Weight Assembly

1. Mount the weight mounting plate to the front panel of the toe board using four 3/8-16 x 1 1/4 inch hex head screws, four washers, four 3/8-16 nyloc nuts.
2. Install the removable weights. Hook the toe board weight assemblies over the top of the weight mounting plate and secure with two hairpins (see Figure 8).

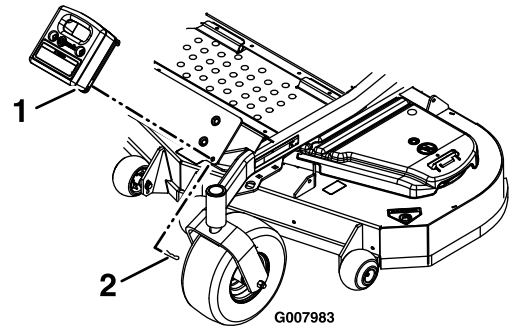

Figure 8

1. Toe board weight
2. Hairpin

Weight Quantities

| Deck Size | 48 inch | 52 inch | 60 inch | 72 inch |
|------------------|---------|---------|---------|---------|
| Toe Board Weight | 3 | 2 | 2 | 1 |
| Caster Weight | — | — | 2 | 2 |

Note: The removable weights are heavy. Use care when lifting them. Make sure that you can hold them securely before lifting them. Use caution when positioning your hands so that you Do Not set them down on your hands or fingers.

3. **For LZUVQD11 and LZUV3B Units Only:**
 - A. Assemble the caster weights to the brackets as shown in Figure 9.

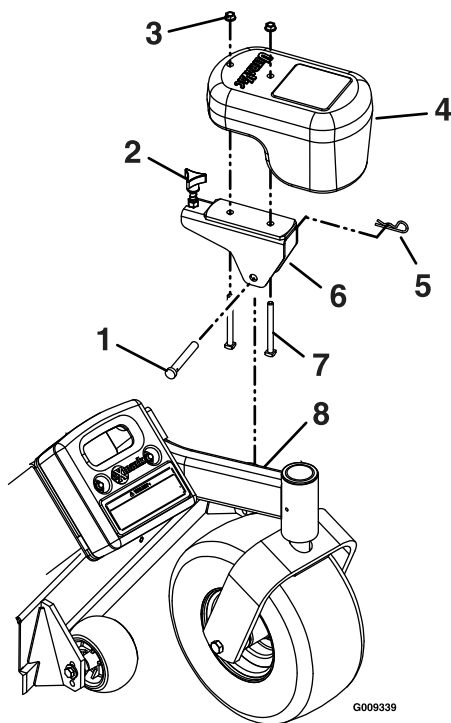

Figure 9

- | | |
|---------------------|--------------------------------|
| 1. Clevis pin | 5. Hairpin |
| 2. Knob | 6. Bracket |
| 3. 3/8-16 nyloc nut | 7. 3/8-16 x 4 inch square bolt |
| 4. Caster weight | 8. Caster arm |

- B. Install the removable caster weights on the caster arms (see Figure 9).
- C. Insert the clevis pin through the bracket hole and fasten with a hairpin.
- D. Tighten knob on weight assembly until the weight is clamped securely to the caster arm.

Note: The portions of the Ultra Vac collection system that are not bolted to the mower are designed to be installed or removed in their entirety. Do Not operate the mower with only a portion of the Ultra Vac installed.

⚠ WARNING

Caster or toe board weights installed without the collection system may cause loss of traction and steering control. Loss of control can result in an accident which may cause death, injury, or property damage.

Install caster or toe board weights **ONLY** when the collection system is installed.

Installing the Belt Cover Bracket

1. Lower the deck fully. Remove and retain the standard right side belt cover, wireform bracket and its hardware.
2. Install the belt cover bracket using the two 3/8-16 x 1 1/4 inch carriage bolts and two 3/8-16 inch nyloc nuts (see Figure 10 or Figure 11).

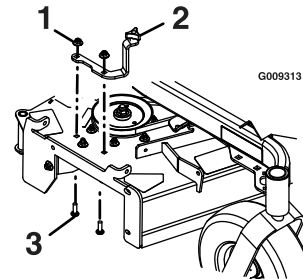

Figure 10

48 and 52 Inch Decks

1. 3/8-16 inch nyloc nut
2. Belt cover bracket
3. 3/8-16 x 1 1/4 inch carriage bolt

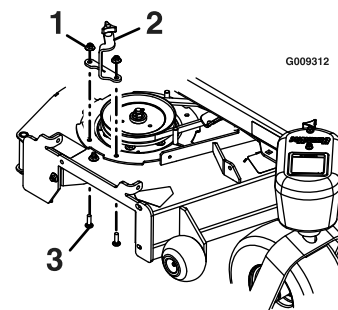

Figure 11

60 and 72 Inch Decks

1. 3/8-16 inch nyloc nut
2. Belt cover bracket
3. 3/8-16 x 1 1/4 inch carriage bolt

Installing the Blower Drive Sheave

1. Remove hairpin, chute pivot pin, and discharge chute. Pivot pin and hair pin may be stored in the pivot holes of the discharge chute during bagging operation.
2. **For Series 4 Decks:**
 - A. Remove the deck drive belt from around the right hand spindle sheave.
 - B. Support the right mower blade and shaft so that it will not fall out of the deck when the right sheave nut is removed.
 - C. Remove the right sheave nut, spring disc washer, and sheave from the spindle shaft.

Block the blade rotation with a block of wood between the blade and baffles as indicated in the blade service section of the Lazer Z Operator's manual. Do Not use the blade bolt to prevent rotation.

- D. Apply a light coat of Mobil HTS grease (or food grade antisieze) to the top portion of the spindle shaft where the sheave mounts.
- E. Install the double sheave onto the right spindle shaft. Install the spring disc washer and nut. Make sure that the spring disc washer cone is installed towards nut (see Figure 12). Torque the sheave nut to 140-145 ft-lb (190–197 N-m).

Block the blade rotation with a block of wood between the blade and baffles as indicated in the blade service section of the Lazer Z Operator's manual. Do Not use the blade bolt to prevent rotation.

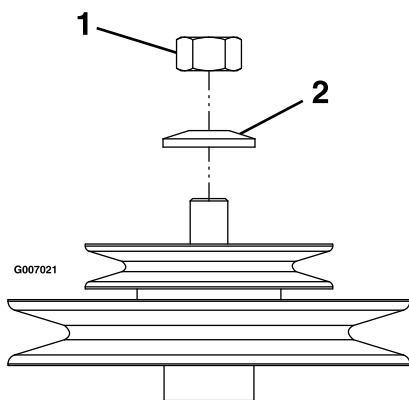

Figure 12

- 1. Torque sheave nut to 140-145 ft-lb (190–197 N-m).
- 2. Install with cone towards nut.

Check blade bolt torque after completing this installation.

Torque blade bolt to 50-60 ft-lb (75-81 N-m).

- F. Re-install the deck drive belt in the lower groove of the double sheave. Install the plug into the bore of the double sheave.

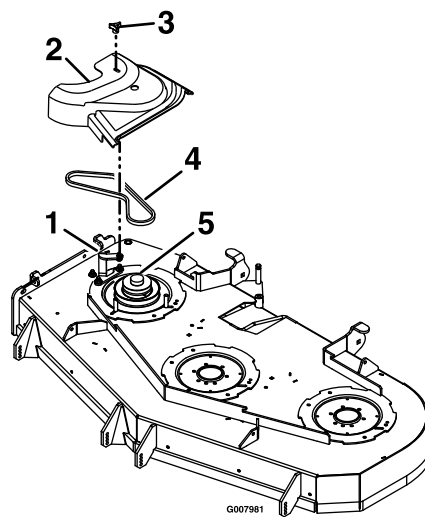

Figure 13

- 1. Belt cover bracket
- 2. Belt cover
- 3. Knob
- 4. Belt
- 5. Deck sheave and nyloc plug

For Series 6 Decks:

- A. Remove the blade from the right spindle.
- B. Insert the special tool 109-2979 into splined end of the spindle shaft.
- C. Remove the right sheave nyloc nut, and splined spacer from the spindle shaft. Do Not remove the blade drive sheave. Retain the nut and splined spacer for later use.

Use special tool 109-2979 to hold spindle from rotating. Do Not use the blade bolt to prevent rotation.

- D. Install the UltraVac drive sheave onto the right spindle shaft. Install the nut removed in step C. Torque the sheave nut to: 5/8-18 inch nut (15/16 Hex) to 90-110 ft-lb (122-149 N-m).

Use special tool 109-2979 to hold spindle from rotating (see Figure 14). Do Not use the blade bolt to prevent rotation.

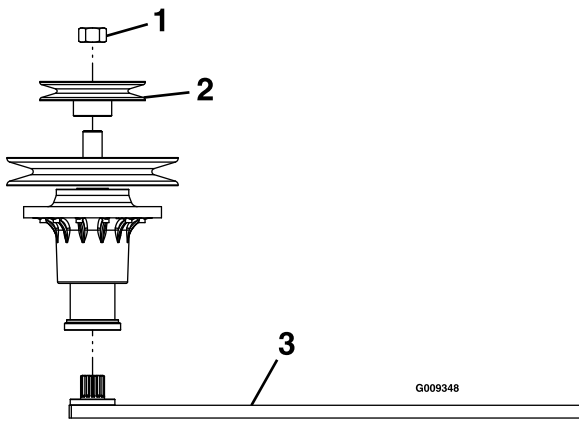

Figure 14

1. 5/8-18 inch Sheave nut-torque to 90-110 ft-lb (122-149 N-m)
2. UltraVac drive sheave
3. Special tool 109-2979

E. Reinstall blade and torque bolt to:

Torque blade bolt to 50-60 ft-lb (75-81 N-m).

F. Reinstall the deck drive belt in the lower groove of the double sheave. Install plug into bore of top sheave.

Installing the Blower Assembly

1. For Small Decks:

A. Slip the belt over the impeller sheave on the blower.

Note: It may be easier to install the belt if the belt guide is temporarily shifted to one side or temporarily removed. Either loosen or remove both nuts on the top and bottom of the belt guide. Once the belt is installed on the impeller sheave, reinstall the belt guide and tighten all hardware.

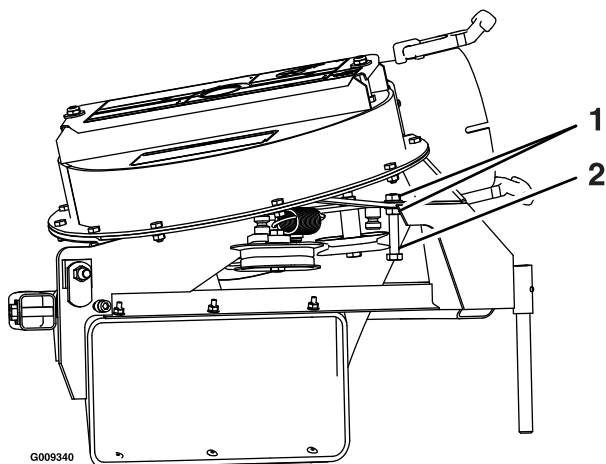

Figure 15

1. Nut
2. Belt guide

B. Mount the blower on the deck by inserting the mounting pin into the tube welded to the rear corner of the deck (see Figure 16).

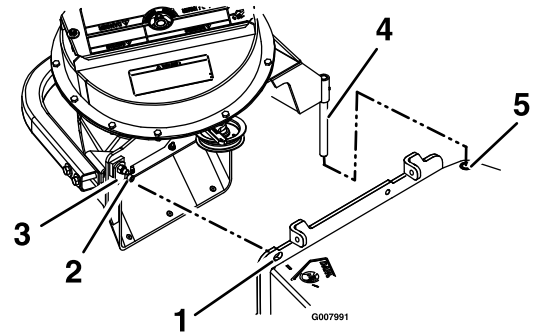

Figure 16

1. Slot
2. Front pin
3. Blower latch
4. Mounting pin
5. Deck tube

C. Pivot the blower until the front pin engages the slot in the deck. Adjust the position of the front pin if necessary to engage the slot. Use the latch to lock the blower in this position. Adjust the tension on the latch to hold the blower up to the deck, yet allow for release by hand.

D. Pull the spring loaded idler release handle back and install the belt in the upper groove of the top spindle sheave. The belt should be routed as shown in Figure 17.

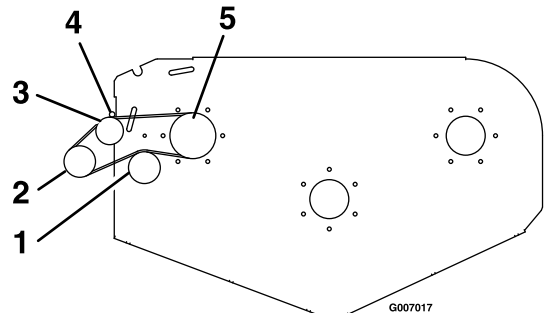

Figure 17

Small Decks — View from Top of Blower

1. Spring loaded idler
2. Impeller sheave
3. Fixed idler
4. Belt guide
5. Deck sheave

2. For Large Decks:

Pull the spring loaded idler back and slip the belt over the top deck sheave.

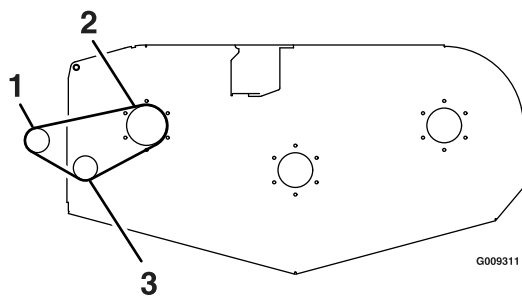

Figure 18

Large Decks — View from Top of Blower

- 1. Impeller sheave
- 2. Deck sheave
- 3. Spring loaded idler

- 3. Position the belt cover at an angle and slide it under the mower frame (see Figure 19).

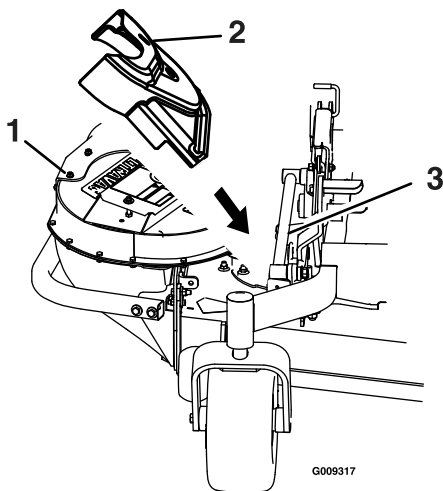

Figure 19

- 1. Blower
- 2. Belt cover
- 3. Mower frame

- 4. Push down on the back of the cover and slide it backwards under the blower.
- 5. With the belt cover resting on the deck, slide it forward until it is seated under both lips on the deck.

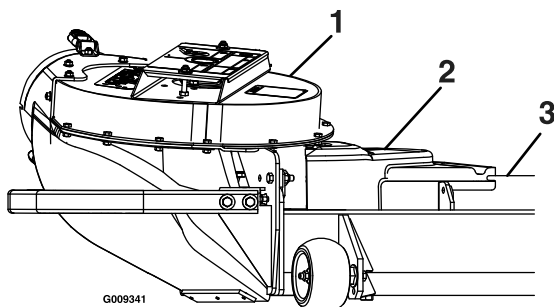

Figure 20

- 1. Blower
- 2. Belt cover
- 3. Deck lip

- 6. Install the knob and its hardware.

Installing the Exhaust Diverter

Loosely install the exhaust diverter to the bagger frame using the hardware shown in Figure 21. This will be adjusted and tightened once the hopper assembly is installed.

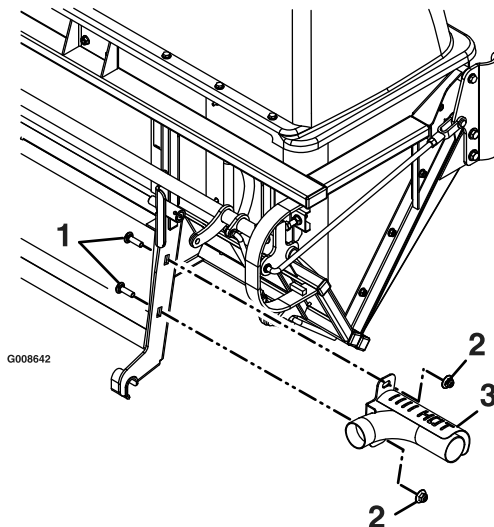

Figure 21

- 1. 3/8-16 x 1 1/4 inch carriage bolt
- 2. 3/8-16 nyloc nut
- 3. Exhaust diverter

Installing the Hopper Assembly

- 1. Lay the hopper assembly down as shown in Figure 22.

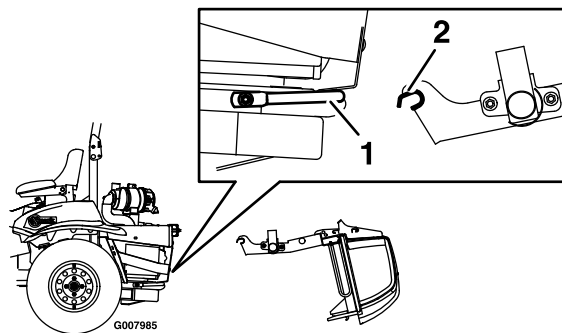

Figure 22

- 1. Lower bagger mount bar
- 2. Bagger frame notch

- 2. Pick up the bagger frame legs and hook the notch onto the lower bagger mount bar (see Figure 22).
- 3. **On LZUVQD7 Units Only:** Remove and retain the knob and carriage bolt from the handle bracket and rotate the dump handle outward. Re-install the knob and carriage bolt.

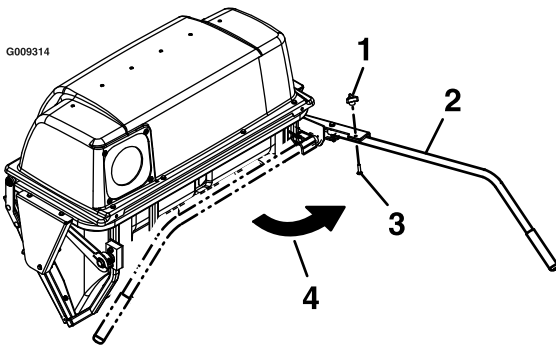

Figure 23
LZUVQD7 Units Only

- | | |
|----------------|-------------------|
| 1. Knob | 3. Carriage bolt |
| 2. Dump handle | 4. Rotate outward |

4. Lift the hopper assembly and pivot it upward towards the back of the unit (see Figure 24).

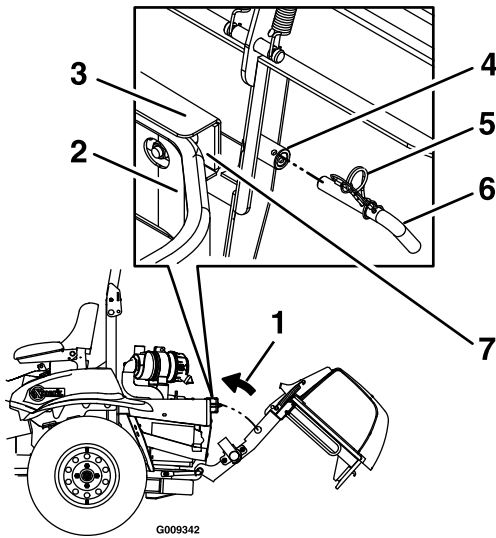

Figure 24

- | | |
|---------------------------|--------------|
| 1. Rotate hopper assembly | 5. Hairpin |
| 2. Rear bumper | 6. Mount pin |
| 3. Mount bracket | 7. Opening |
| 4. Frame mount barrel | |

5. Continue to push the hopper assembly forward until it contacts the mount bracket.
6. Adjust the exhaust diverter up or down in the slots so it fits over the muffler.
7. If needed, install washers between the exhaust diverter and the frame to space the guard outward.
8. Install the mount pin into the frame mount barrel. Make sure that it extends into the opening between the rear bumper and the mount bracket (see Figure 24).
9. Align the holes in the mount pin and frame mount barrel and insert the hairpin to lock the hopper assembly into place.

10. Tighten the hardware on the exhaust diverter.

11. For LZUV2B & LZUV3B Units:

- A. Raise the hood and install the bag assemblies by sliding the bag frame hooks onto the retaining slots on the hopper frame.
- B. Close and latch the hood.

12. For the LZUVQD11 Units:

- A. Unlatch the spring clevis pin from the handle link.
- B. Rotate the handle link towards the actuation arm bracket and align the holes as shown in Figure 25.
- C. Insert the spring clevis pin and rotate downward to latch it onto the handle assembly.

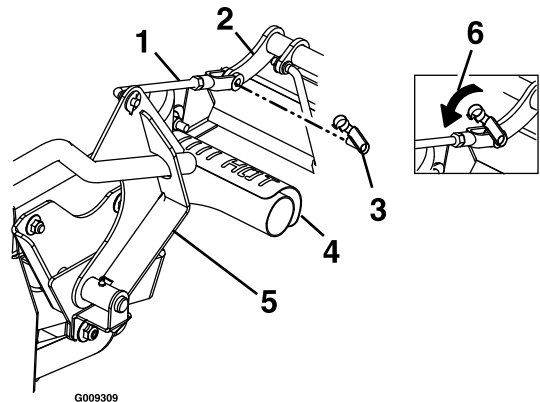

Figure 25

- | | |
|--------------------------|-----------------------------|
| 1. Handle link | 4. Exhaust diverter |
| 2. Actuation arm bracket | 5. Handle assembly |
| 3. Spring clevis pin | 6. Rotate downward to latch |

Assembling the Tubes

1. For 60 inch decks, shorten the upper tube.
- A. Locate the three holes in the upper tube. Measure 6 1/2 inches (16.5 cm) up from the end of the tube and mark the location in all three areas (see Figure 26).

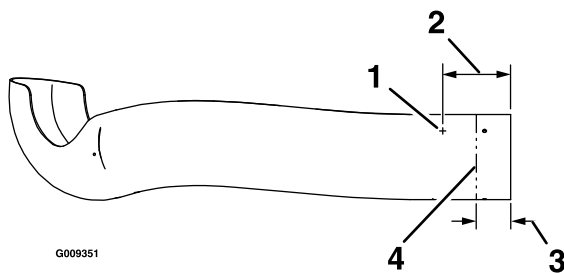

Figure 26

1. New hole location
2. Measure 6 1/2 inches (16.5 cm)
3. Measure 3–3 1/2 inches (7.6–8.9 cm)
4. Cut tube

B. Drill three 3/8 inch holes.

C. Measure 3–3 1/2 inches from the end of the tube, create marks, and apply masking tape around the tube as a guide.

D. Carefully cut the tube and discard the end.

2. Slip the upper and the lower tubes together.
3. Insert the upper tube into the hopper seal – push in then pull out so that the seal is extended outward.
4. Align the dimple on the upper tube with the end of hopper seal and center between the two screws as shown in Figure 27.

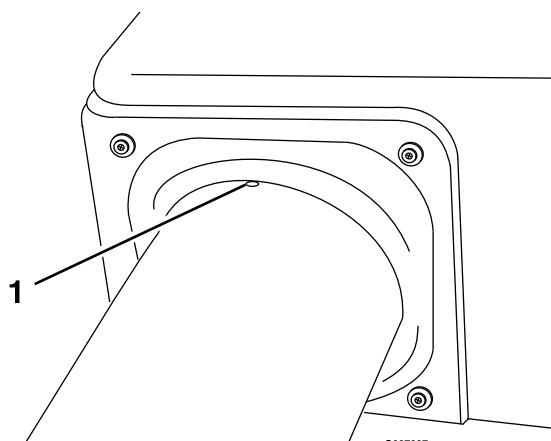

Figure 27

1. Dimple

hex washer head screws, three #10 washers, and three #10-24 nyloc nuts. The screw head should be installed to the inside of the tube to provide minimum obstruction to flow. Make sure that the upper and the lower ends are oriented properly as the tubes are assembled. (Parting lines should roughly be lined up.)

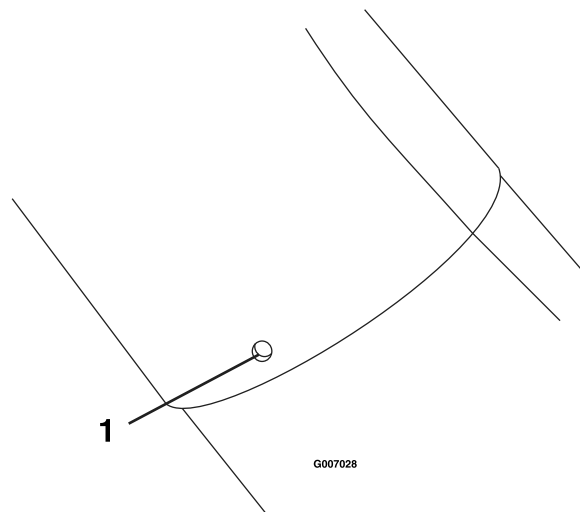

Figure 28

1. Drill the holes here

Adjusting the Blower Drive Belt Position

5. **Set the deck in lowest cutting position.**
6. Slide the lower tube onto the blower and attach the latches. (Make sure that the upper tube does not move out of alignment).
7. Drill the 7/32 inch holes in the lower tube using the upper tube holes as reference. See Figure 28.
8. Remove the tubes from unit and assemble the upper and the lower tubes using three #10-24 x 3/4 inch

1. Read the operator's manual for the UltraVac and mower before performing this adjustment. Make sure that you understand the controls, their locations their functions and safety requirements.
2. Ensure the blower, belt cover, bags, tube and hood are in good condition, properly attached and latched.
3. Run the unit with the PTO and the blower engaged for two minutes.
4. Disengage the PTO, stop the engine and remove the key.
5. Remove the belt cover and check to make sure that the belt is riding near the center of the flat idler on the idler arm. If the belt is not riding near the center of the idler, remove the blower, and bend the idler arm slightly.
6. Reinstall the blower and belt cover and perform steps 3-5 again to verify belt position.

Adjusting the Door Linkage

Note: The LZUVQD7 and LZUVQD11 units were adjusted at the factory to operate properly. However, adjustments can be made if your unit requires them:

LZUVQD7 Units:

1. If the door does not close properly adjust the rods as shown in Figure 29.

- Shorten the rod to increase over center force.
- Lengthen the rod to reduce.

Adjust the rods on both sides so they are approximately equal.

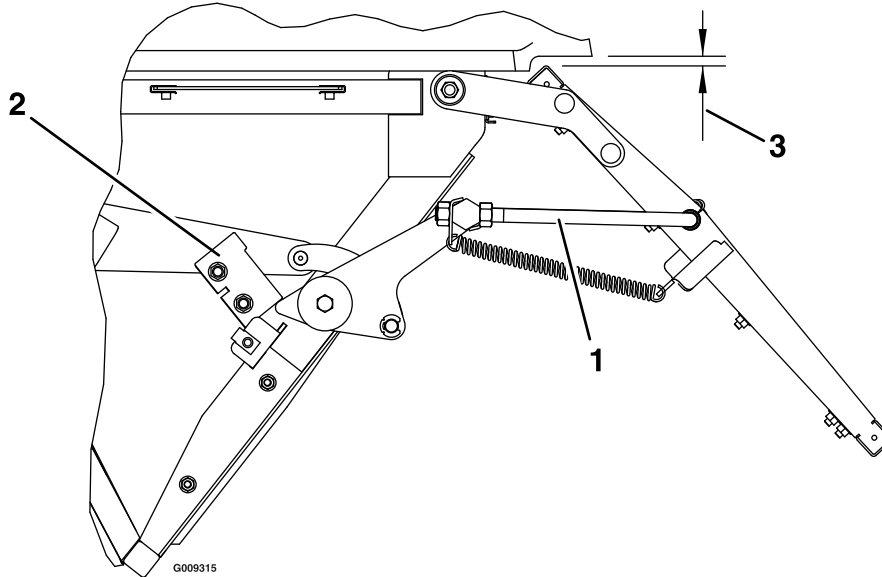

Figure 29
LZUVQD7 Units

1. Rod
2. Stop

3. $1/4$ inch (6.35 mm) \pm $1/8$ inch (3.2 mm)

2. If the left and right stops do not make contact with the door link when it is in the extended position:

Adjust the position of the stops (see Figure 29) so that the door link contacts them when the upper tube of the door frame is within $1/4$ inch (6.35 mm) \pm $1/8$ (3.2 mm) from the lower lip of the molded hood.

LZUVQD11 Units:

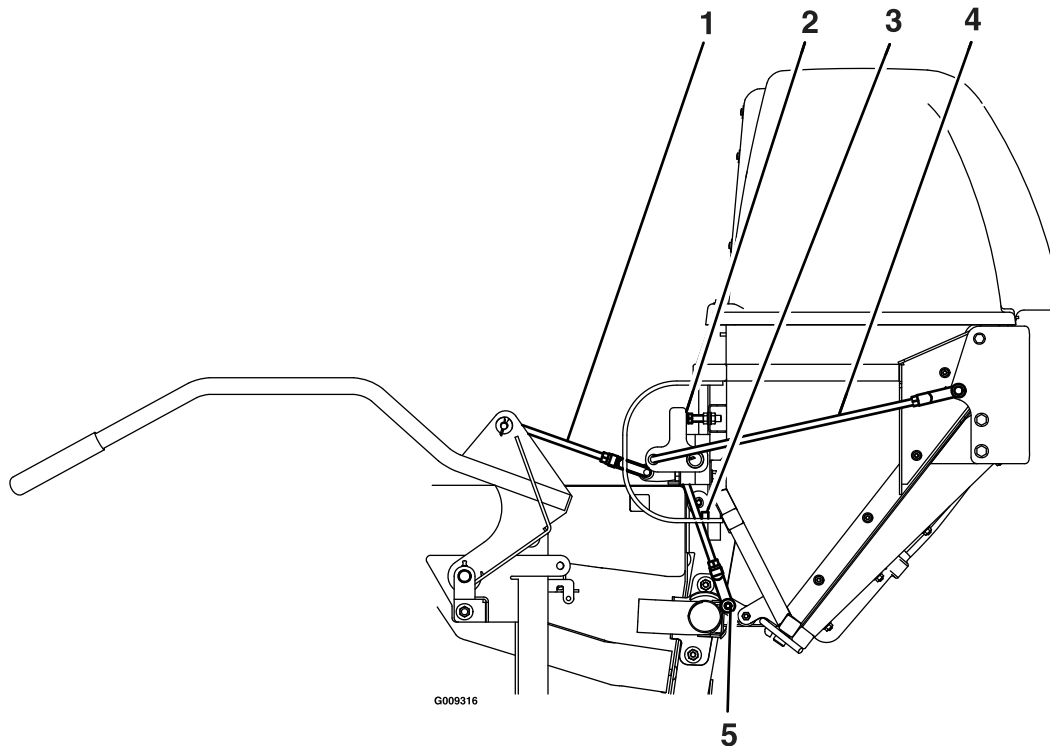

Figure 30
LZUVQD11 Units

- | | | |
|----------------|----------------|------------|
| 1. Handle Link | 3. Stop | 5. Latches |
| 2. Stop Screws | 4. Hinge Links | |

- Door closing:** The closing of the door is controlled by the two hinge links and the two stop screws (see Figure 30). The stop screws should be adjusted so that both will be contacted when the contacting arm is straight up and down. With the stop screws adjusted, the length of the hinge links can be changed to provide complete closing of the door, and reasonable force on the handle to latch or unlatch the door. Lengthen the links to reduce the force. Shorten the links to increase the force. With the door closed, both links should be slightly tight to minimize rattling.
- Door opening:** After adjusting the hinge links for door closing, the handle link can be adjusted to obtain maximum door opening (see Figure 30). Lengthen the link to open the door farther. Shorten the link to open the door less. The maximum door opening is limited by the contacting arm hitting the stop. This stop is non adjustable, and prevents over opening damage from occurring to the linkage.
- Latches:** Once the open and closed positions have been set, the latches can be adjusted (see Figure 30). With the door closed, the latch link should be set so that the latch plate completely engages and contacts the latch rod welded to the door. The latch plates should not be tight against the latch rod. They should easily “wobble”.

Fill Out Warranty Registration Form

Fill out the online warranty registration form.