



**Count on it.**

**Parts Catalog**

**Z Master<sup>®</sup> G3 Riding Mower  
with 72in TURBO FORCE<sup>®</sup> Side Discharge  
Mower**

**Model No. 74927—Serial No. 290000001 and Up**

# Ordering Replacement Parts

To order replacement parts, please supply the part number, the quantity, and the description of each part desired.

## Understanding Reference Numbers

Each identified part in an illustration has a reference number. The reference number for a part also appears in the parts list, along with other information about the part.

This catalog uses two special reference number formats, one to indicate parts in a service assembly and another to indicate the quantity of a given part in an illustration.

## Service Assembly Reference Numbers

Parts in service assemblies have reference numbers in the form a:b. The a represents the reference number of the entire service assembly and the b represents a sequential number unique to each part within the service assembly.

For example, a wheel assembly might be identified by reference number 6, the tire by 6:1, the valve by 6:2, and the wheel by 6:3. When you order the assembly identified by reference number 6, you receive all parts identified by reference numbers 6:1, 6:2, and 6:3. However, you may also order any part individually. Reference numbers of this type appear in illustration and in parts lists.

## Reference Numbers Indicating Quantity

In an illustration, if a reference number indicates more than one part, the reference number has the form nX y. The n represents the quantity of the part, the X is the multiplication symbol, and the y represents the reference number.

For example, in an illustration, the reference number 2X 37 means that two of the parts identified by reference number 37 are indicated.

# List of Abbreviations

**AR:** as required

**ASM:** assembly

**BBC:** blade brake control

**BHTF:** button head thread forming

**CARR:** carriage

**CCW:** counter clockwise

**CW:** clockwise

**DEG:** degrees

**ECM:** electronic control module

**EXT:** external

**FH:** flat head

**GA:** gauge

**HD:** heavy-duty

**HF:** hex flange

**HH:** hex head

**HHF:** hex head flange

**HHFTF:** hex head flange thread forming

**HJ:** hex jam

**HLH:** hex lag head

**HOC:** height-of-cut

**HSBH:** hex socket button head

**HSFH:** hex socket flat head

**HSH:** hex socket head

**HWH:** hex washer head

**HWHTF:** hex washer head thread forming

**HYD:** hydraulic

**LH:** left hand

**LP:** Liquid Propane

**NI:** nylon insert

**NPTF:** national pipe thread fine

**PFH:** phillips flat head

**PPH:** phillips pan head

**PPHTF:** phillips pan head thread forming

**PRH:** phillips round head

**PTH:** phillips truss head

**PTO:** power-take-off

**RH:** right hand

**ROPS:** roll-over protection system

**RRB:** rear roller brush

**SFH:** slotted fillister head

**SHH:** slotted hex head

**SHWH:** slotted hex washer head

**SPH:** slotted pan head

**SQH:** square head

**SRH:** slotted round head

**STD:** standard

**TAP:** self tapping

**TTH:** torx truss head

# Contents

Front Frame and Caster Wheel Assembly	4
Roll-Over Protection System Assembly No. 116-0231	5
Caster Wheel and Fork Assembly	6
Hydraulic Pump, Idler and Belt Assembly	7
Pump Idler Assembly No. 116-1185	8
LH Hydro Assembly No. 116-1326	9
RH Hydro Assembly No. 116-1327	10
Rear Wheel and Park Brake Assembly	11
Brake Handle Assembly No. 117-0383	12
Fuel System Assembly	13
Fuel Tank Assembly No. 109-9357	14
Seat Mounting Assembly	15
Seat Assembly No. 116-0035	16
Motion Control Assembly	17
Fender, Console and Control Assembly	18
LH Console Assembly No. 115-7401	19
RH Console Assembly No. 115-7400	20
Electrical System Assembly	21
Deck Lift Assembly	22
Height-of-Cut Assembly No. 109-7438	23
Engine, Muffler and Clutch Assembly	24
Deck Assembly	25
Deck Decal Assembly No. 112-4195	26
Idler Assembly	27
Spindle Assembly No. 110-3933	28
Rubber Deflector Assembly No. 108-2792	29
Lever Assembly No. 107-1664	30
Cylinder and Crankcase Assembly Kawasaki FX801V-AS04	31
Piston and Crankshaft Assembly Kawasaki FX801V-AS04	32
Valve and Camshaft Assembly Kawasaki FX801V-AS04	33
Lubrication Equipment Assembly Kawasaki FX801V-AS04	34
Cooling Equipment Assembly Kawasaki FX801V-AS04	35
Electric Equipment Assembly Kawasaki FX801V-AS04	36
Control Equipment Assembly Kawasaki FX801V-AS04	37
Carburetor Assembly Kawasaki FX801V-AS04	38
Air Filter and Muffler Assembly Kawasaki FX801V-AS04	40
Fuel Tank and Fuel Valve Assembly Kawasaki FX801V-AS04	41
Starter Assembly Kawasaki FX801V-AS04	42
Label Set Kawasaki FX801V-AS04	43
Attachments and Accessories	44

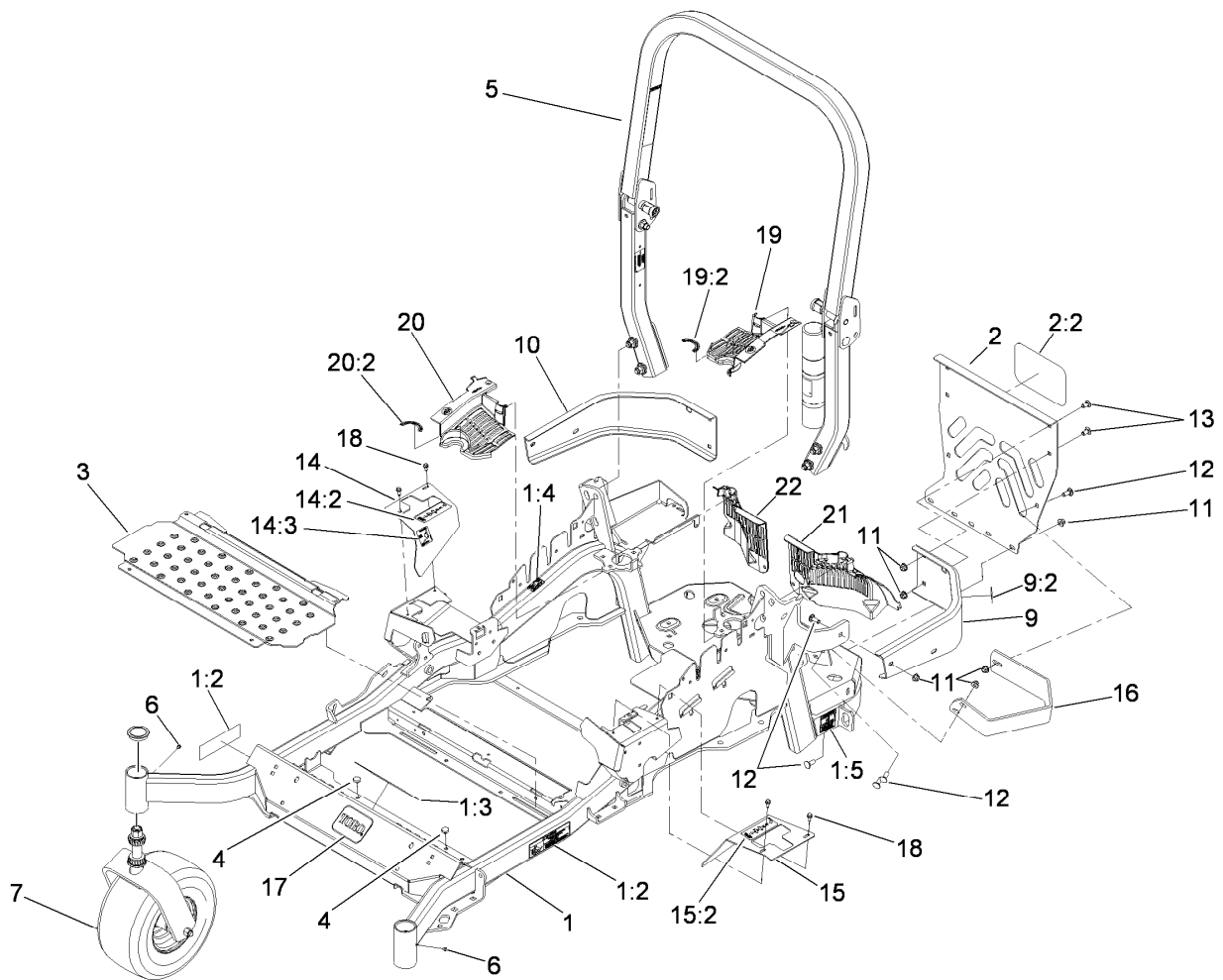

## Front Frame and Caster Wheel Assembly

Ref.	Part Number	Qty.	Description	Ref.	Part Number	Qty.	Description
1	109-7349	1	Main Frame ASM	13	3231-21	4	Screw-CARR
1:2	109-9477	2	Decal-Warning	14	116-0579	1	RH Motion Control Cover ASM
1:3	107-2112	1	Decal-Warning	14:2	109-7232	1	Decal-Motion Control
1:4	103-2076	2	Decal-Caution	14:3	109-7929	1	Decal-Park Brake
1:5	116-0205	2	Decal-Belt Drive	15	116-0580	1	LH Motion Control Cover ASM
2	115-7410	1	Rear Guard ASM	15:2	109-7232	1	Decal-Motion Control
2:2	67-7320	1	Decal	16	116-0043-03	1	Guard-Muffler
3	116-0024-01	1	Floorpan	17	68-3640	1	Decal
4	1-513658	2	Bumper	18	32144-10	4	Screw-HWH
5	116-0231	1	ROPS ASM	19	116-0170	1	LH Hydro Guard ASM
6	1-811010	2	Plug	19:2	116-0157	1	Decal-Hydro Oil
7		2	Caster Wheel ASM ●	20	116-0171	1	RH Hydro Guard ASM
9	116-0180	1	LH Bumper ASM	20:2	116-0157	1	Decal-Hydro Oil
9:2	103-2076	1	Decal-Caution	21	109-9057	1	Guard-Hydro, Rear LH
10	116-0057-03	1	Bumper-RH	22	109-9058	1	Guard-Hydro, Rear RH
11	104-8301	11	Nut-Flange, NI				
12	3231-22	7	Screw-CARR				

● Not serviced separately

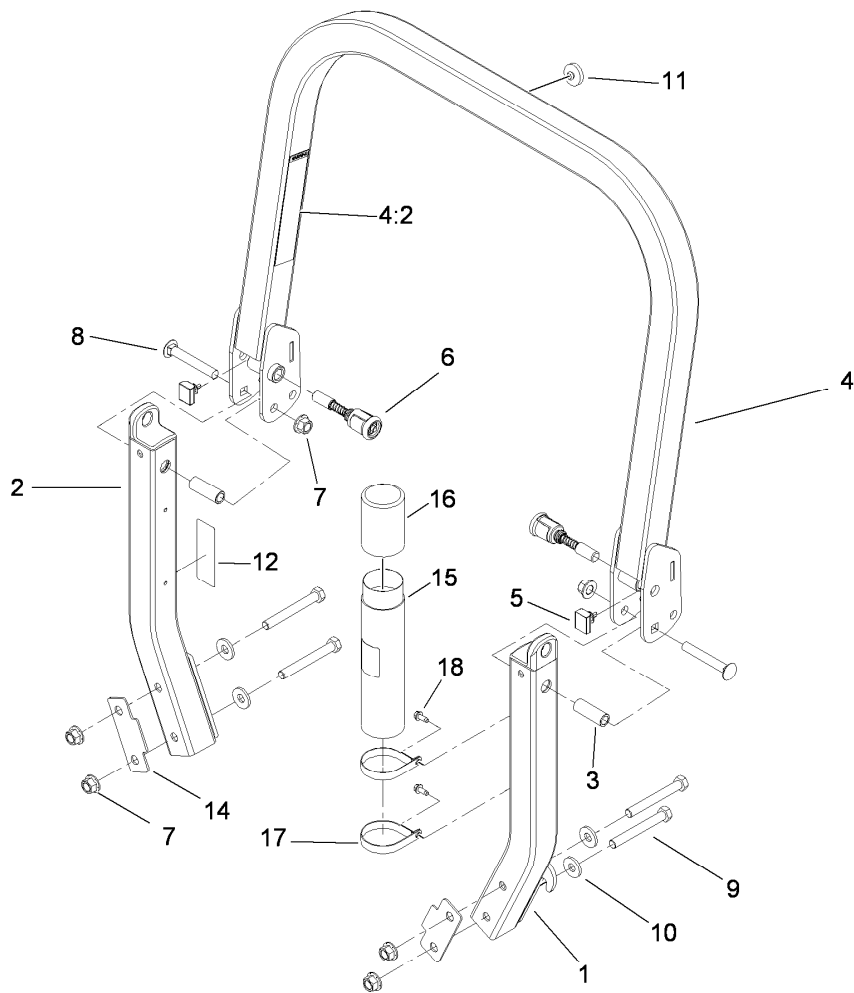

## Roll-Over Protection System Assembly No. 116-0231

Ref.	Part Number	Qty.	Description
1		1	Leg-ROPS, LH ●
2		1	Leg-ROPS, RH ●
3	109-6653	2	Spacer
4		1	Upper ROPS ASM ●
4:2	107-2102	1	Decal-Warning, Folding ROPS
5	109-5337	2	Bumper-ROPS
6	116-0104	2	Spring Pin ASM
7	99-5107	6	Nut-Lock
8	3233-10	2	Screw-CARR
9	325-17	4	Screw-HH
10	1-513435	4	Washer-Spring
11	109-9233	1	Bumper-Push-In, Rubber
12	116-0090	1	Decal-Caution
14	116-0960	2	Spacer
15	104-7050	1	Tube-Manual
16	104-7048	1	Cap-Housing
17	107-1865	2	R-Clamp
18	32144-10	2	Screw-HWH

● Not serviced separately

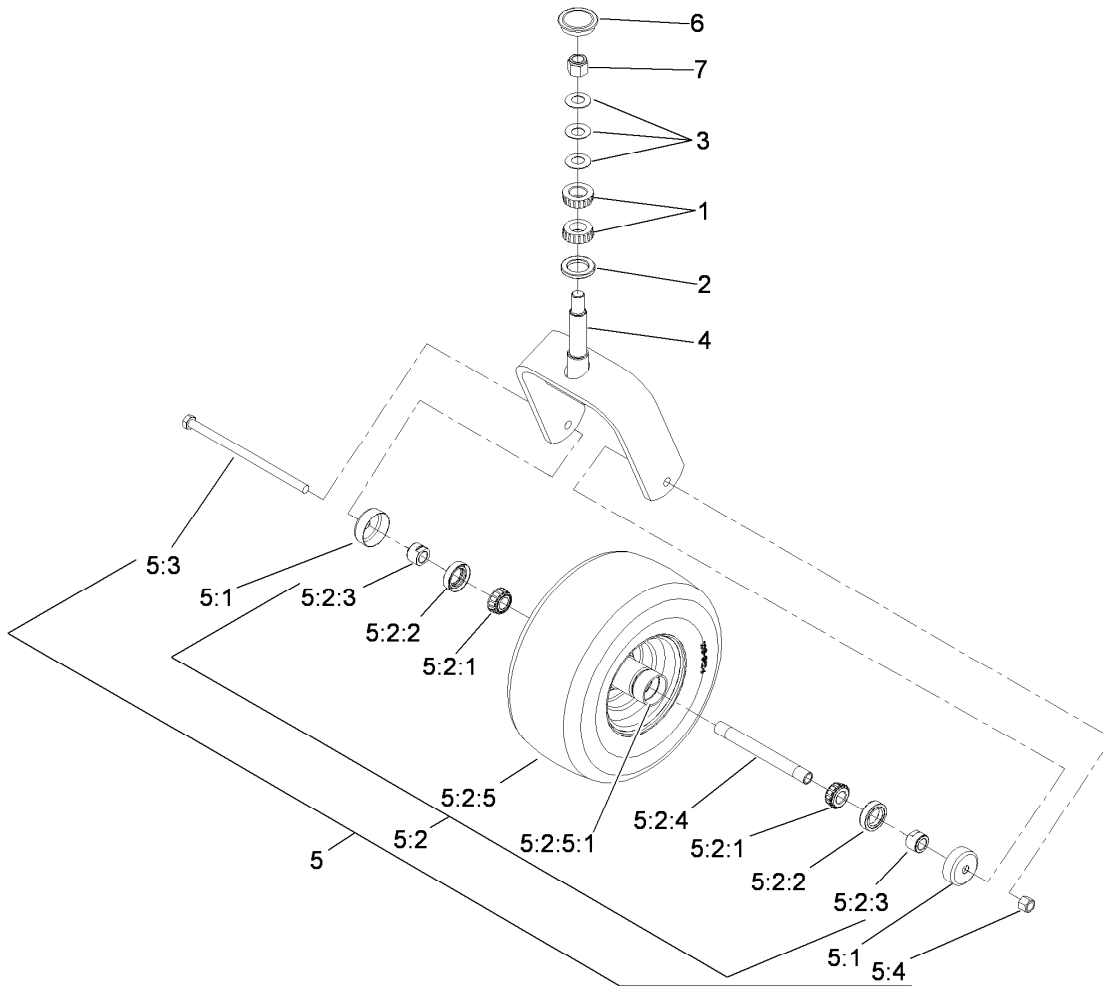

## Caster Wheel and Fork Assembly

Ref.	Part Number	Qty.	Description
1	1-543509	2	Bearing-Roller, Tapered
2	1-543511	1	Seal-Grease
3	1-633508	3	Washer-Bellville
4	103-1474-01	1	Caster-Fork
5	109-9127	1	Wheel And Tire ASM
5:1	103-2768	2	Guard-Seal
5:2		1	Wheel And Tire ASM ●
5:2:1	1-633585	2	Bearing-Cone, Taper
5:2:2	103-0063	2	Seal-Caster
5:2:3	103-3051	2	Spacer-Nut
5:2:4	103-5156	1	Axle-Caster
5:2:5		1	Wheel And Tire ASM ●
5:2:5:1	1-633584	1	Bearing-Cup
5:3	325-39	1	Screw-HH
5:4	3296-23	1	Nut-Lock, NI
6	103-4882	1	Cap-Grease
7	3296-51	1	Nut-Lock, NI

● Not serviced separately

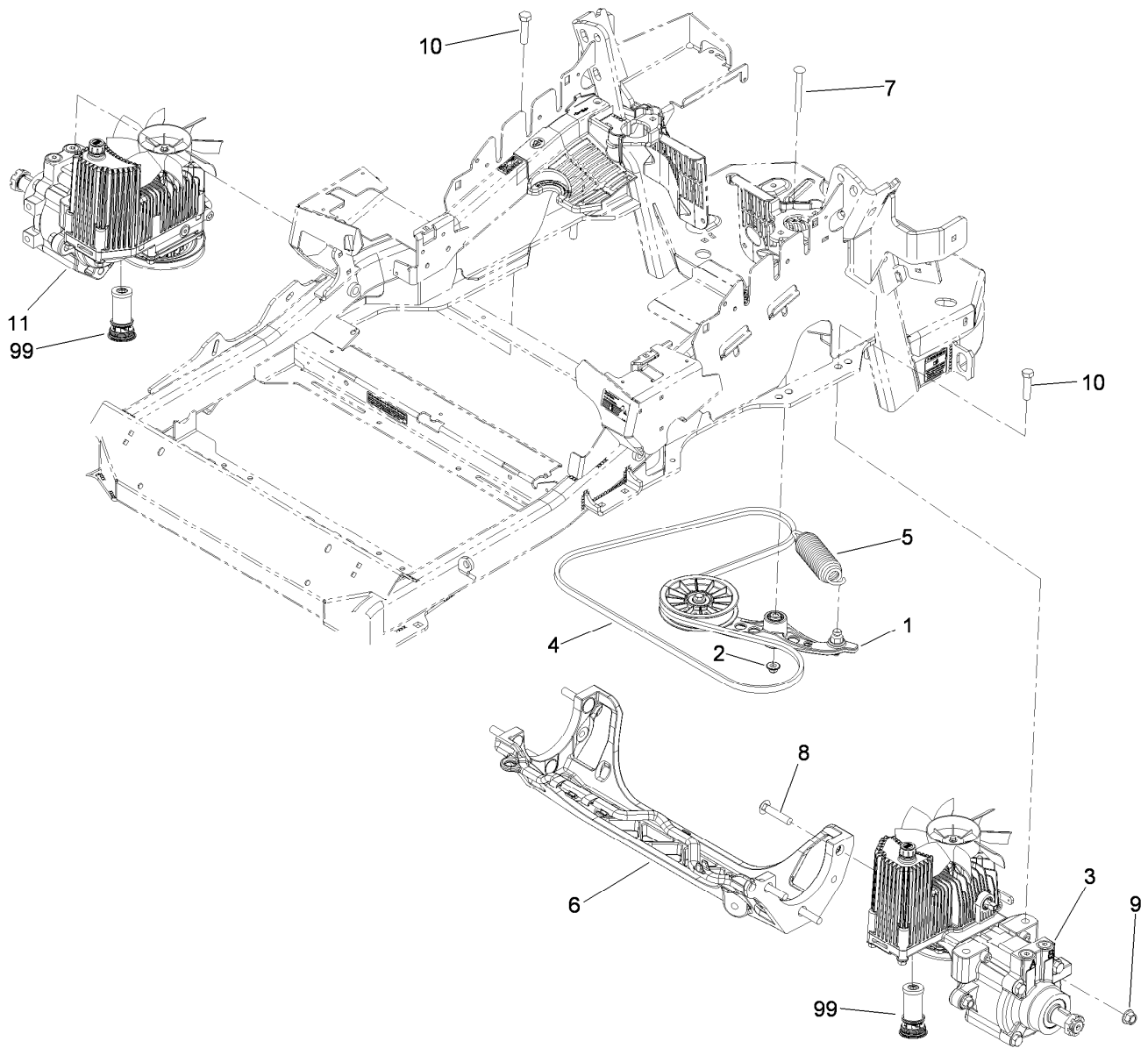

## Hydraulic Pump, Idler and Belt Assembly

Ref.	Part Number	Qty.	Description
1	116-1185	1	Pump Idler ASM
2	109-6658	1	Nut-Flange, NI
3	116-1326	1	LH Hydro ASM (16Cc W/Shock)
4	109-3388	1	Belt
5	116-0133	1	Extension-Spring
6	109-9375	1	Cradle-Hydro
7	3231-41	1	Bolt-Carriage
8	3233-34	6	Screw-CARR
9	99-5107	6	Nut-Lock
10	325-8	4	Screw-HH
11	116-1327	1	RH Hydro ASM (16Cc W/Shock)
99	114-4713	1	Hypr-Oil 500 (Quart) ●
99	114-4714	1	Hypr-Oil 500 (Gallon) ●
99	114-4715	1	Hypr-Oil 500-5 (5 Gallon) ●
99	117-0390	1	Filter-Hydro

● Not illustrated

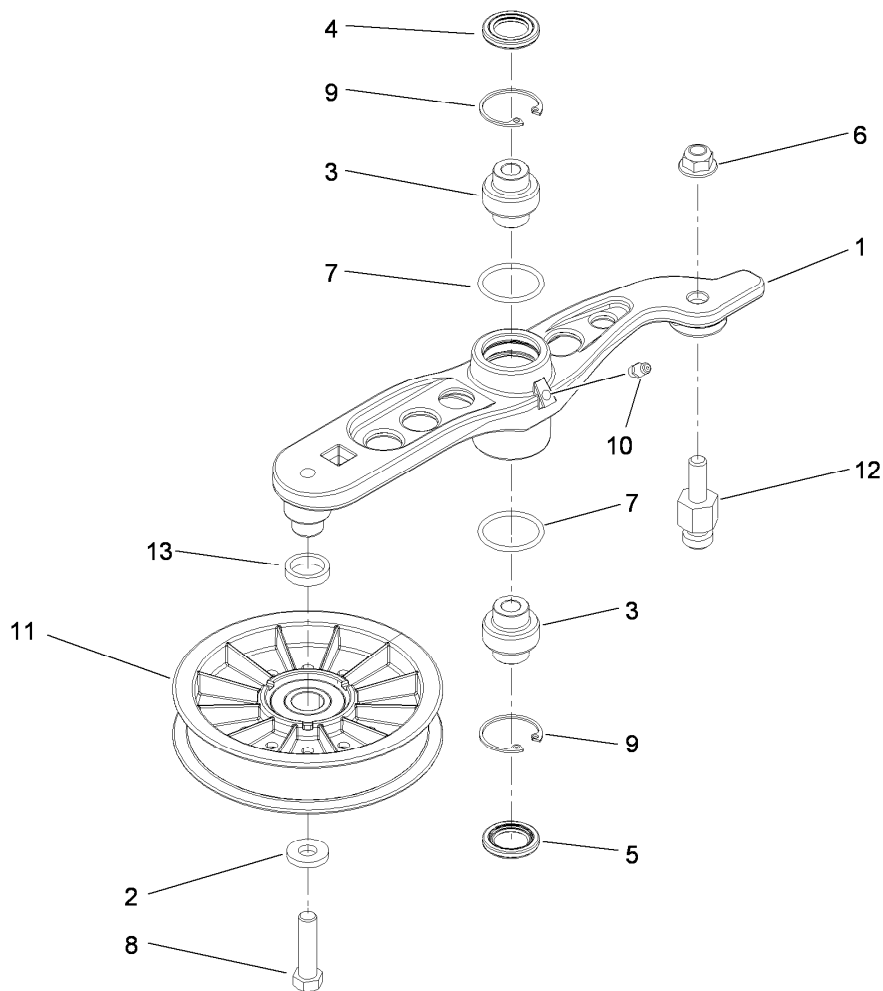

## Pump Idler Assembly No. 116-1185

<i>Ref.</i>	<i>Part Number</i>	<i>Qty.</i>	<i>Description</i>
1		1	Arm-Idler, Hydro ●
2	43-0940	1	Spacer-Hub, Blower
3	103-3504	2	Bearing-Spherical
4	103-3505	1	Seal-Double Lip
5	103-3506	1	Seal-Single Lip
6	104-8301	1	Nut-Flange, NI
7	106-7159	2	O-Ring
8	323-8	1	Screw-HH
9	32120-10	2	Ring-Snap
10	302-19	1	Fitting-Grease
11	109-8076	1	Pulley-Idler
12	109-7399	1	Pin-Anchor, Spring
13	116-1217	1	Spacer

● Not serviced separately



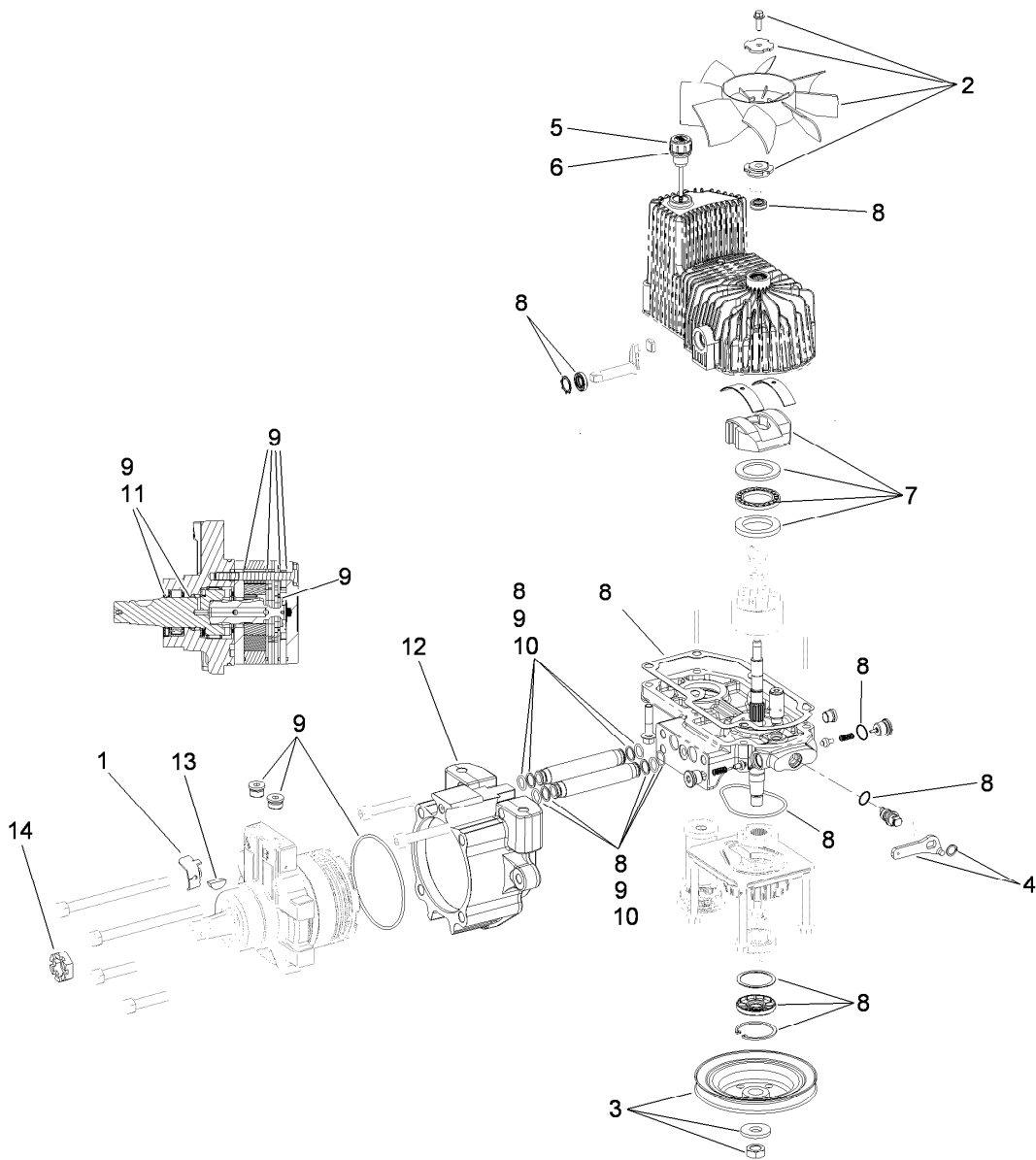

## LH Hydro Assembly No. 116-1326

Ref.	Part Number	Qty.	Description
1	116-1758	1	Bracket-Anchor, Cable
2	116-0233	1	Fan Kit
3	116-0234	1	Pulley Kit
4	116-0235	1	Handle-Bypass Valve, Hydro
5	116-0236	1	Dipstick-Hydro W/Gasket
6	116-0237	1	Gasket-Dipstick, Hydro
7	116-1367	1	Swash Block Kit
8	116-1368	1	Pump Seal Kit
9	116-1369	1	Motor Seal Kit
10	116-1370	1	Tube Seal Kit
11	116-1371	1	Output Shaft Seal Kit
12	116-1372	1	Cup-Nose
13	3257-42	1	Key-Woodruff
14	1-809036	1	Nut-HH
99	116-1373	1	Flow Test Kit ●

● Not illustrated

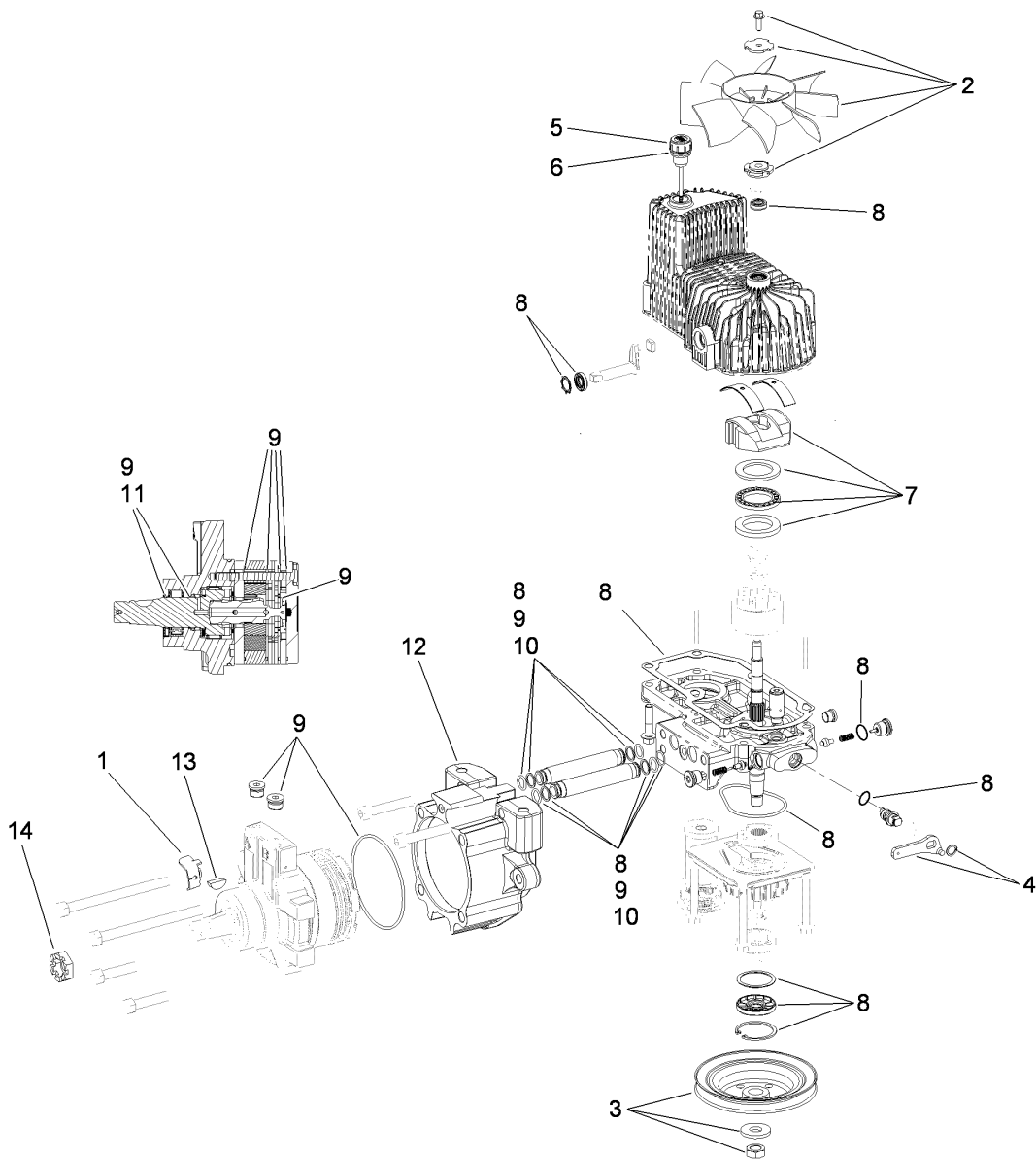

## RH Hydro Assembly No. 116-1327

Ref.	Part Number	Qty.	Description
1	116-1758	1	Bracket-Anchor, Cable
2	116-0233	1	Fan Kit
3	116-0234	1	Pulley Kit
4	116-0235	1	Handle-Bypass Valve, Hydro
5	116-0236	1	Dipstick-Hydro W/Gasket
6	116-0237	1	Gasket-Dipstick, Hydro
7	116-1367	1	Swash Block Kit
8	116-1368	1	Pump Seal Kit
9	116-1369	1	Motor Seal Kit
10	116-1370	1	Tube Seal Kit
11	116-1371	1	Output Shaft Seal Kit
12	116-1372	1	Cup-Nose
13	3257-42	1	Key-Woodruff
14	1-809036	1	Nut-HH
99	116-1373	1	Flow Test Kit ●

● Not illustrated

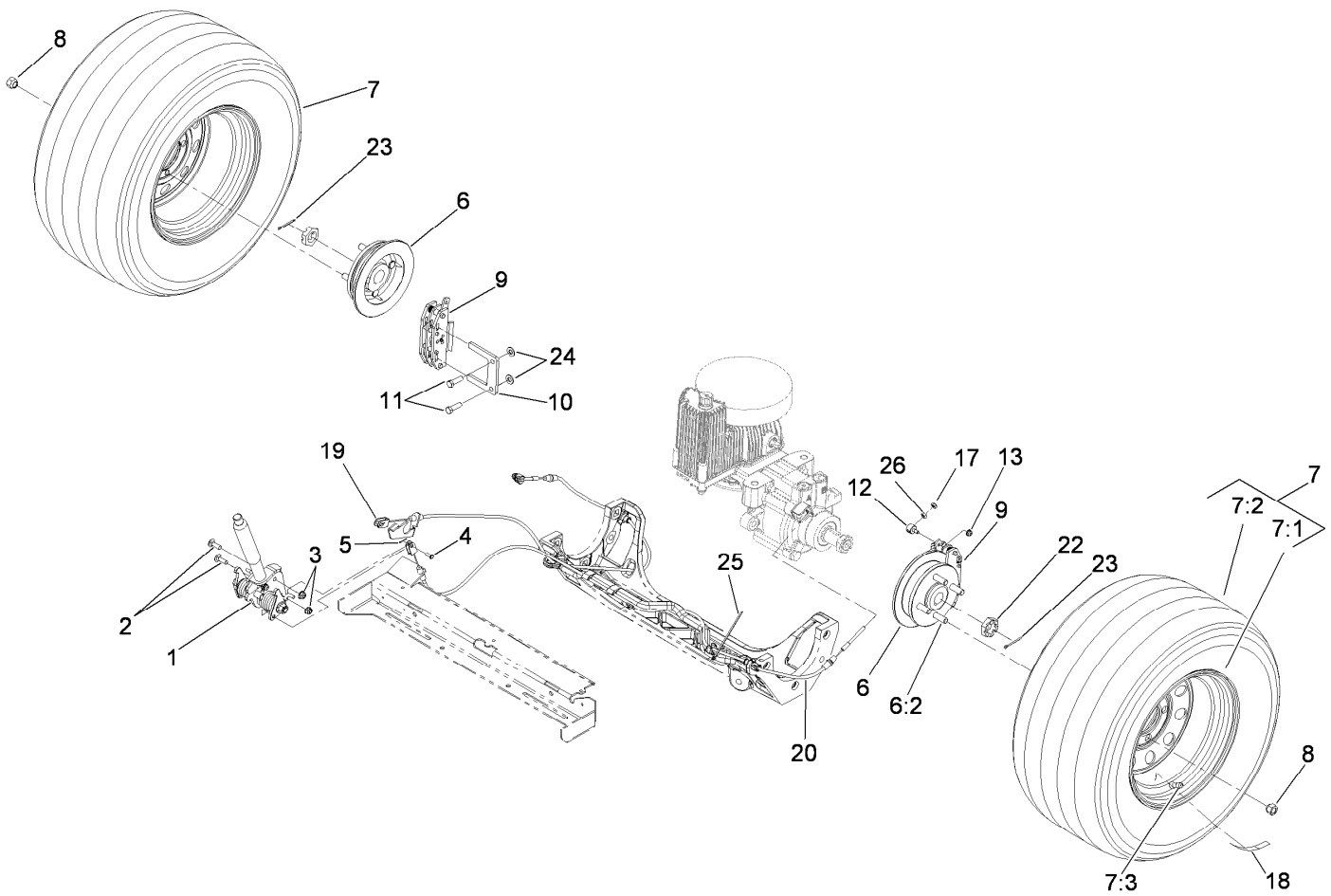

## Rear Wheel and Park Brake Assembly

Ref.	Part Number	Qty.	Description
1	117-0383	1	Brake Handle ASM
2	3230-2	2	Bolt-CARR
3	104-8300	2	Nut-Flange, NI
4	60-1730	2	Pin-Clevis
5	3272-1	2	Pin-Cotter
6	115-3624	2	Wheel Hub And Stud ASM
6:2	1-633926	4	Stud-Wheel
7	109-3158	2	Wheel And Tire ASM
7:1	109-3156	1	Rim ASM
7:2	103-2744	1	Tire
7:3	232-27	1	Stem-Valve
8	242-50	8	Nut-Lug
9	109-2889	2	Caliper-Brake

Ref.	Part Number	Qty.	Description
10	109-0958	2	Plate-Mount, Brake
11	323-7	4	Screw-HH
12	112-8379	2	Swivel
13	104-7201	2	Nut-HF
17	3296-13	2	Nut-Lock NI
18	116-0165	2	Decal-Hub, Wheel
19	115-3584	1	Cable
20	115-3585	1	Cable
22	1-809036	2	Nut-HH
23	1-806800	2	Pin-Cotter
24	3256-24	4	Washer-Flat
25	116-0940	1	Tie-Cable
26	3219-1	2	Nut-Hex

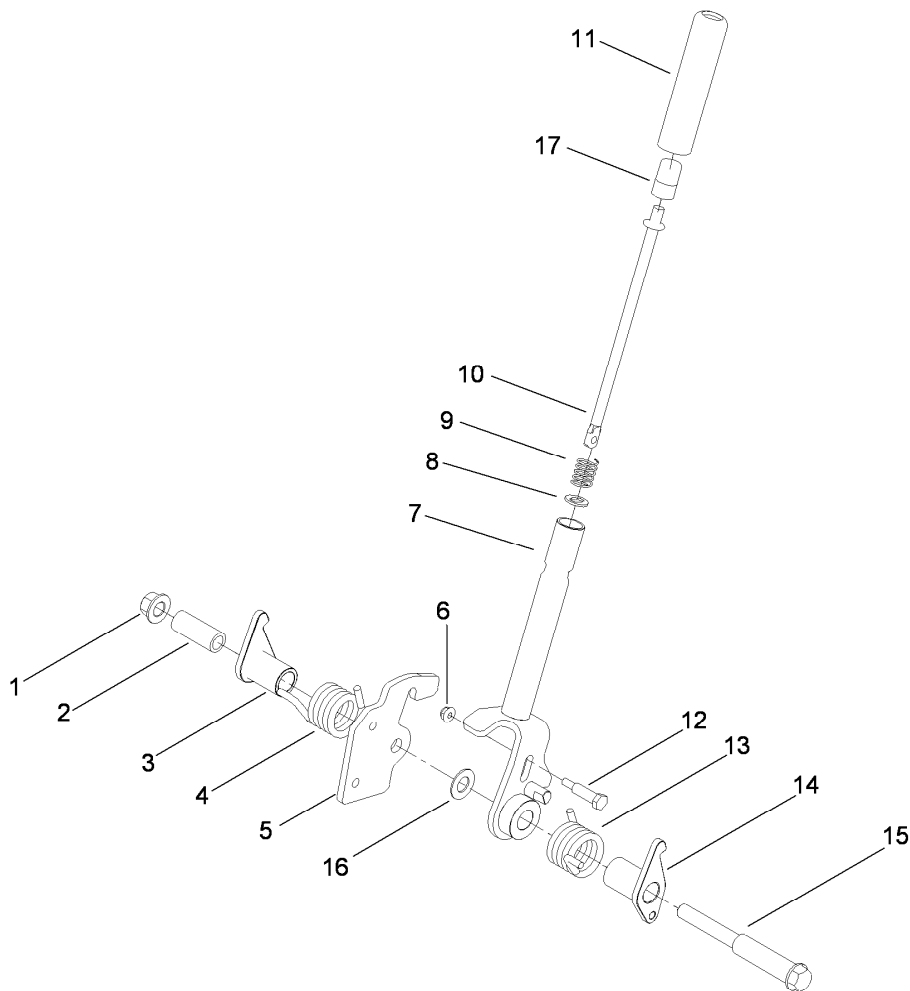

## Brake Handle Assembly No. 117-0383

<i>Ref.</i>	<i>Part Number</i>	<i>Qty.</i>	<i>Description</i>
1	99-5107	1	Nut-Lock
2	117-0380	1	Spacer
3	115-3580	1	Arm-Brake, LH
4	117-0376	1	Spring-Torsion, RH
5	115-3574	1	Plate-Latch
6	104-7201	1	Nut-HF
7	117-0382-03	1	Brake Handle ASM
8	114-1207	1	Washer-Special
9	114-8187	1	Spring-Compression
10	115-3581	1	Rod-Release, Brake
11	115-3592	1	Grip
12	112-8387	1	Bolt-Shoulder
13	117-0375	1	Spring-Torsion, LH
14	115-3579	1	Arm-Brake, RH
15	117-0379	1	Bolt-Shoulder
16	117-0378	1	Washer
17	115-2750	1	Knob

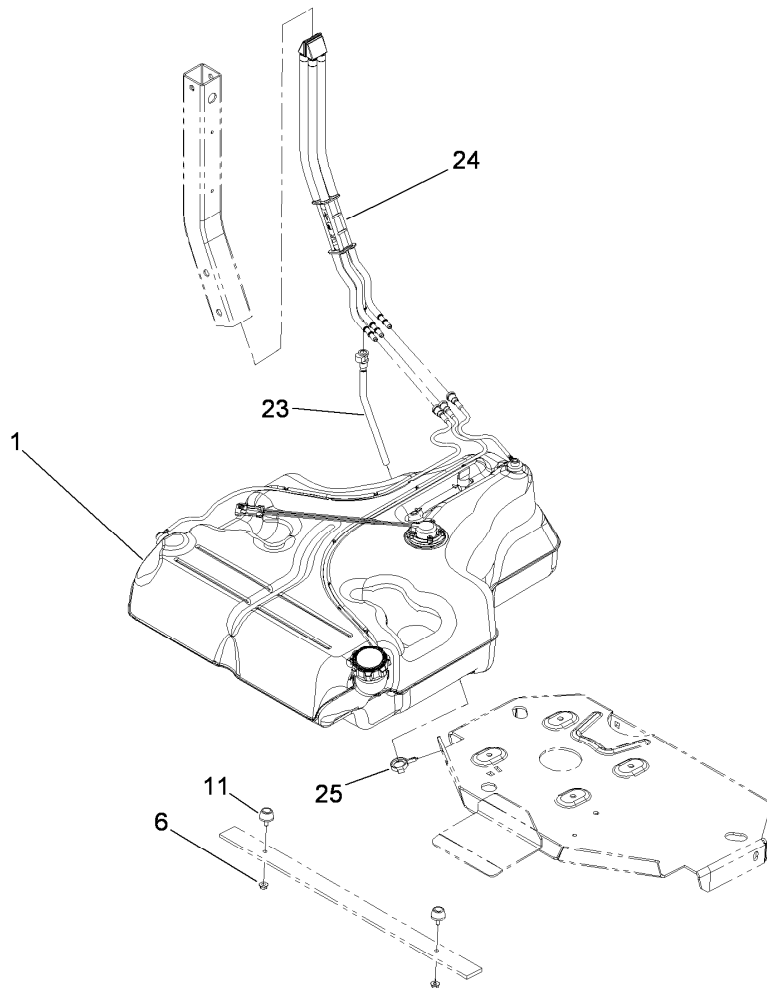

## Fuel System Assembly

<i>Ref.</i>	<i>Part Number</i>	<i>Qty.</i>	<i>Description</i>
1	109-9656	1	Fuel Tank ASM (W/O Sender)
1	109-9357	1	Fuel Tank ASM
6	32128-33	2	Nut-HF
11	109-2365	2	Bumper-Rubber (W/Stud)
23	109-9450	1	Tube-Vent, Fuel Drain
24	109-9491	1	Fuel Manifold Vent ASM
25	105-1853	1	Clamp-Hose

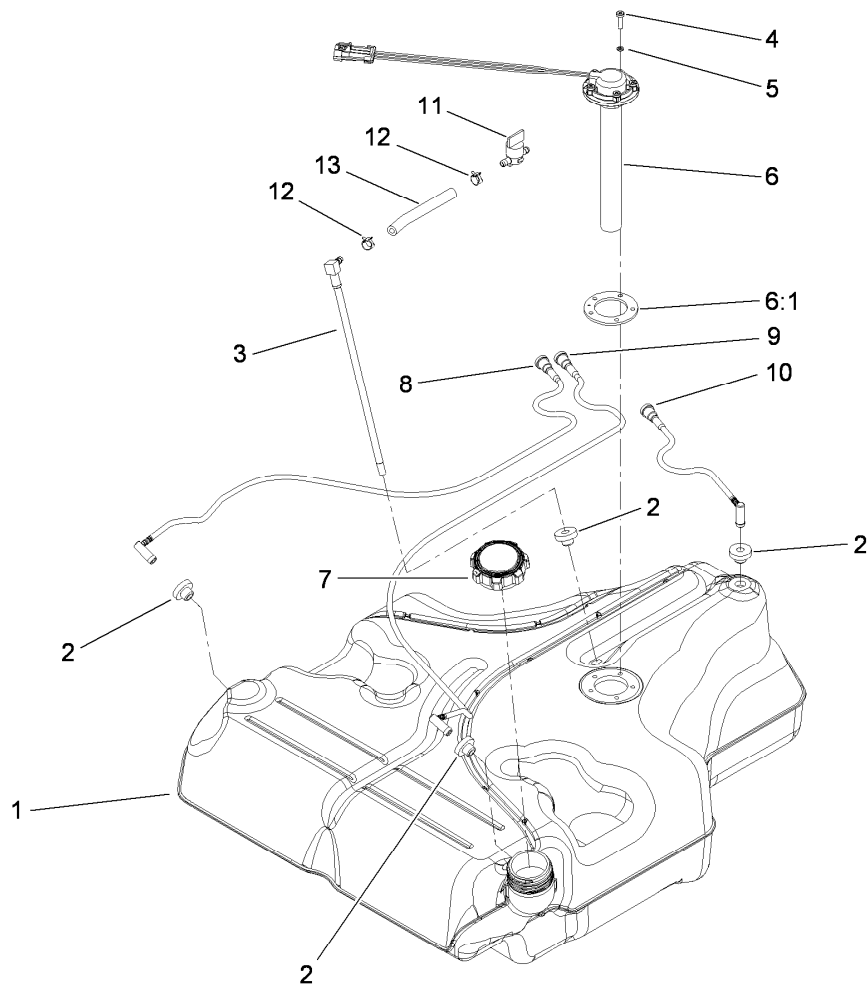

## Fuel Tank Assembly No. 109-9357

Ref.	Part Number	Qty.	Description
1		1	Tank-Fuel, Belly ●
2	46-6560	4	Bushing
3	109-9364	1	Fitting-Fuel (W/Line And Screen)
4	9107944	5	Screw-Pan
5	3253-17	5	Washer-Lock
6	116-0003	1	Sender-Fuel Level
6:1	109-9620	1	Gasket-Sender, Fuel
7	109-9619	1	Cap-Fuel
8	109-9447	1	Tube-Vent, RH
9	109-9448	1	Tube-Vent, LH
10	109-9449	1	Tube-Vent, Rear
11	1-603770	1	Valve-Fuel
12	2412-98	2	Clamp
13	109-0650	1	Hose-Fuel

● Not serviced separately

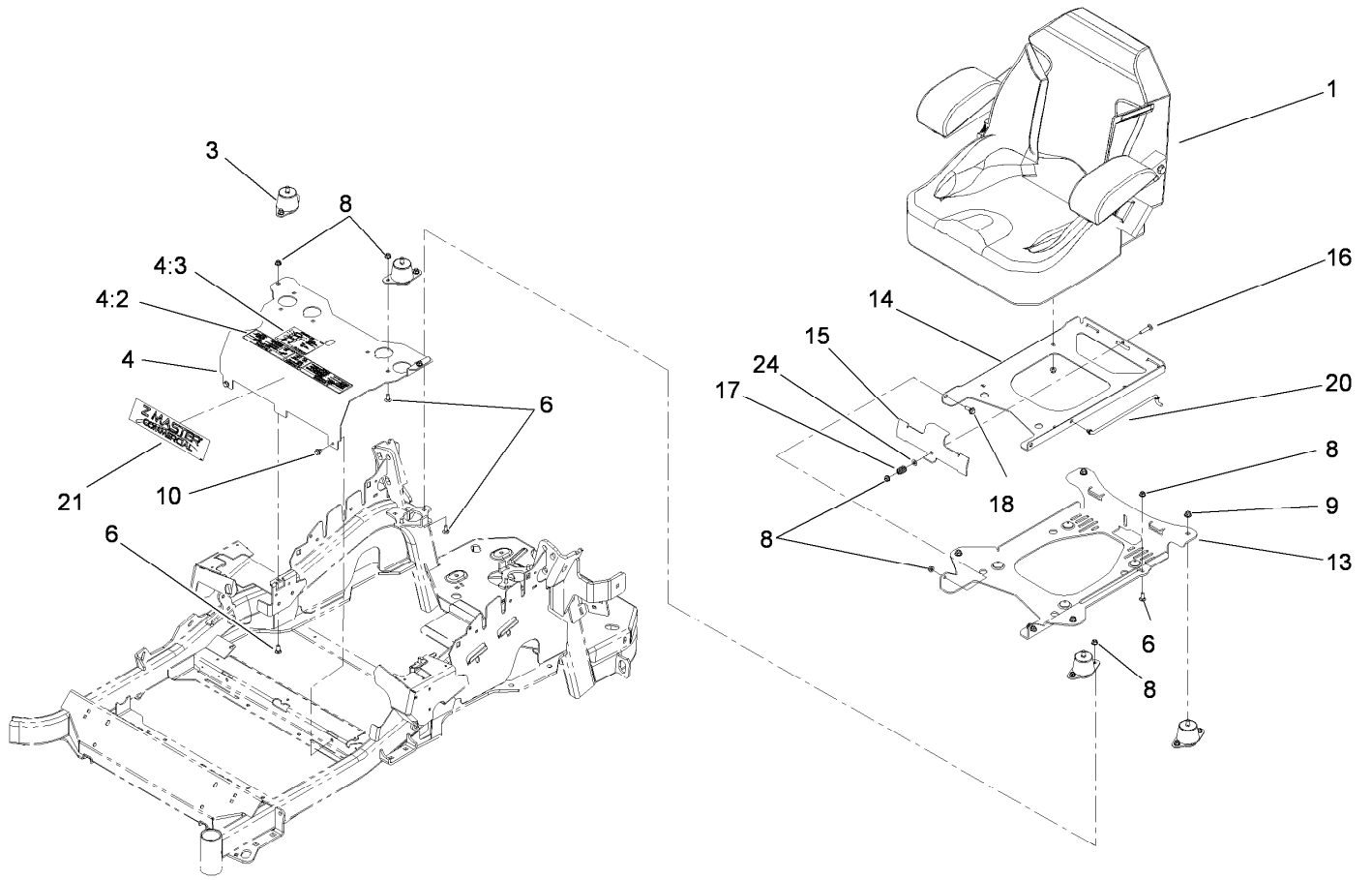

## Seat Mounting Assembly

<i>Ref.</i>	<i>Part Number</i>	<i>Qty.</i>	<i>Description</i>
1	116-0035	1	Seat-Standard
3	109-9034	4	Isolator-Seat
4	109-9036	1	Mount-Seat
4:2	109-7069	1	Decal-Console
4:3	116-0211	1	Decal-Service Aid
6	3230-23	11	Screw-CARR
8	104-8300	18	Nut-Flange, NI
9	104-8301	4	Nut-Flange, NI
10	9266934	2	Screw
13	116-0181-03	1	Plate-Support, Seat Tilt
14	116-0179-03	1	Plate-Frame, Seat Tilt
15	109-9881-03	1	Plate-Latch, Seat
16	3230-4	1	Screw-CARR
17	107-3017	1	Spring-Compression
18	99-5284	2	Screw-Shoulder
20	116-0070	1	Rod-Prop
21	114-5878	1	Decal-Dash
24	3256-23	1	Washer-Flat

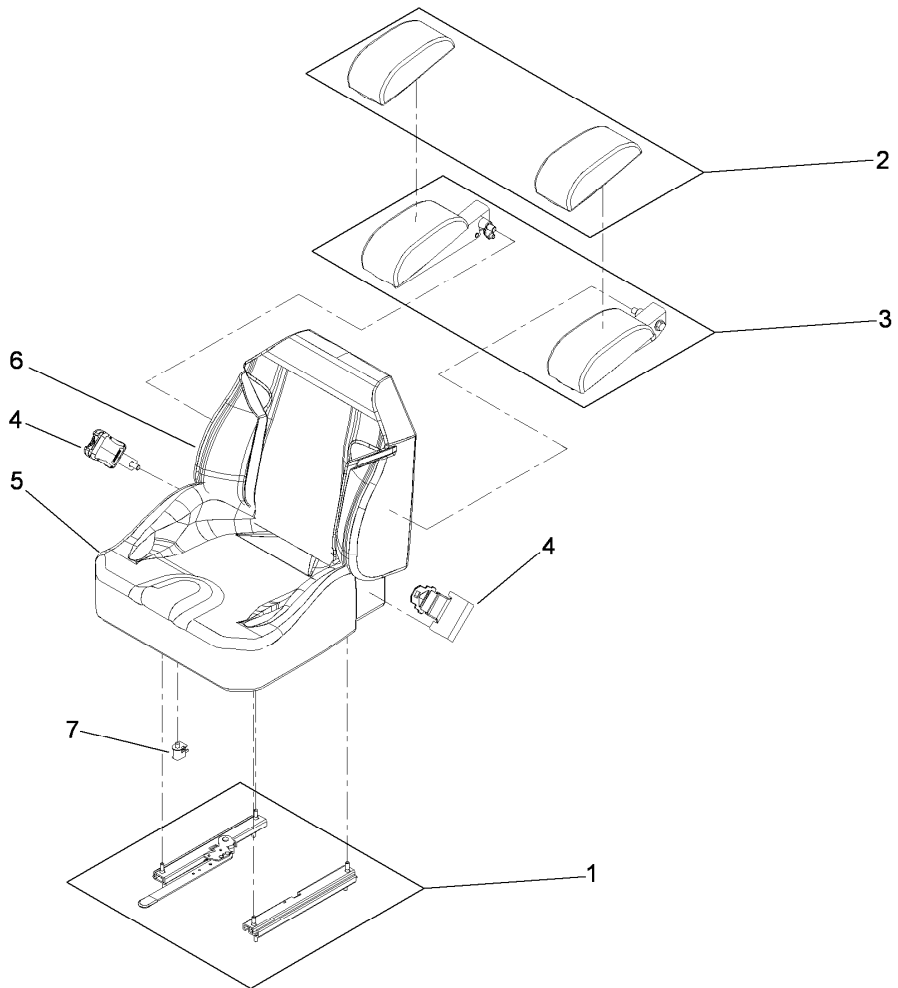

## Seat Assembly No. 116-0035

<i>Ref.</i>	<i>Part Number</i>	<i>Qty.</i>	<i>Description</i>
1	109-9801	1	Seat Track Set
2	109-9802	1	Arm Rest Pad Set
3	109-9803	1	Arm Rest Set
4	109-9805	1	Seat Belt Kit
5	109-9806	1	Cover-Cushion
6	109-9808	1	Cover-Back
7	82-2190	1	Switch-Bail



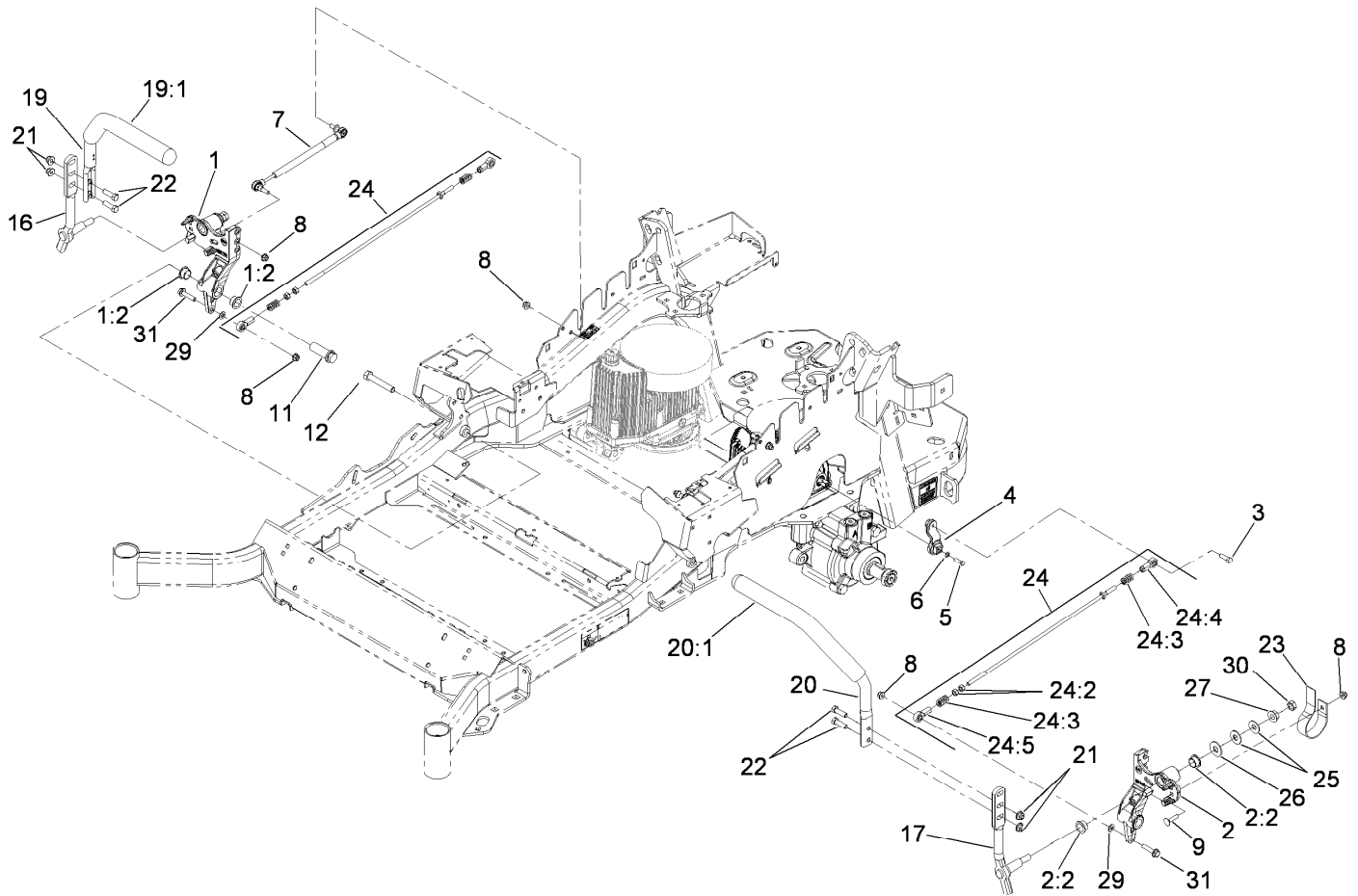

## Motion Control Assembly

<i>Ref.</i>	<i>Part Number</i>	<i>Qty.</i>	<i>Description</i>	<i>Ref.</i>	<i>Part Number</i>	<i>Qty.</i>	<i>Description</i>
1	116-0880	1	RH Motion Control And Bushing ASM	19:1	106-9987	1	Grip-Control, Motion
1:2	109-8054	4	Bushing-Flange	20	109-6592	1	LH Steering Handle ASM
2	116-0881	1	LH Motion Control And Bushing ASM	20:1	106-9987	1	Grip-Control, Motion
2:2	109-8054	4	Bushing-Flange	21	104-8301	4	Nut-Flange, NI
3	116-0648	2	Screw-Thread Locking	22	323-7	4	Screw-HH
4	109-4581	2	Arm-Control, Pump	23	109-5575	2	Spring-Leaf
5	9080046	2	Screw-HH	24	109-8106	2	Front Pump Linkage ASM
6	1-303435	2	Washer-Spring	24:2	3219-2	2	Nut-Hex
7	116-0027	2	Damper-Control, Motion	24:3	1-323245	2	Spring-Compression
8	104-8300	8	Nut-Flange, NI	24:4	1-633152	1	Balljoint-LH
9	3230-2	2	Bolt-CARR	24:5	1-543017	1	Balljoint-RH
11	109-5891	2	Hub-Threaded	25	109-9505	4	Washer-Spring
12	325-12	2	Screw-HH	26	3256-6	2	Washer-Flat
16	116-0039	1	Lever-Control Motion, RH	27	32128-23	2	Nut-HF
17	116-0040	1	Lever-Control Motion, LH	29	3256-23	2	Washer-Flat
19	109-6591	1	RH Steering Handle ASM	30	3218-5	2	Nut-Jam
				31	115-1794	2	Screw-HHF

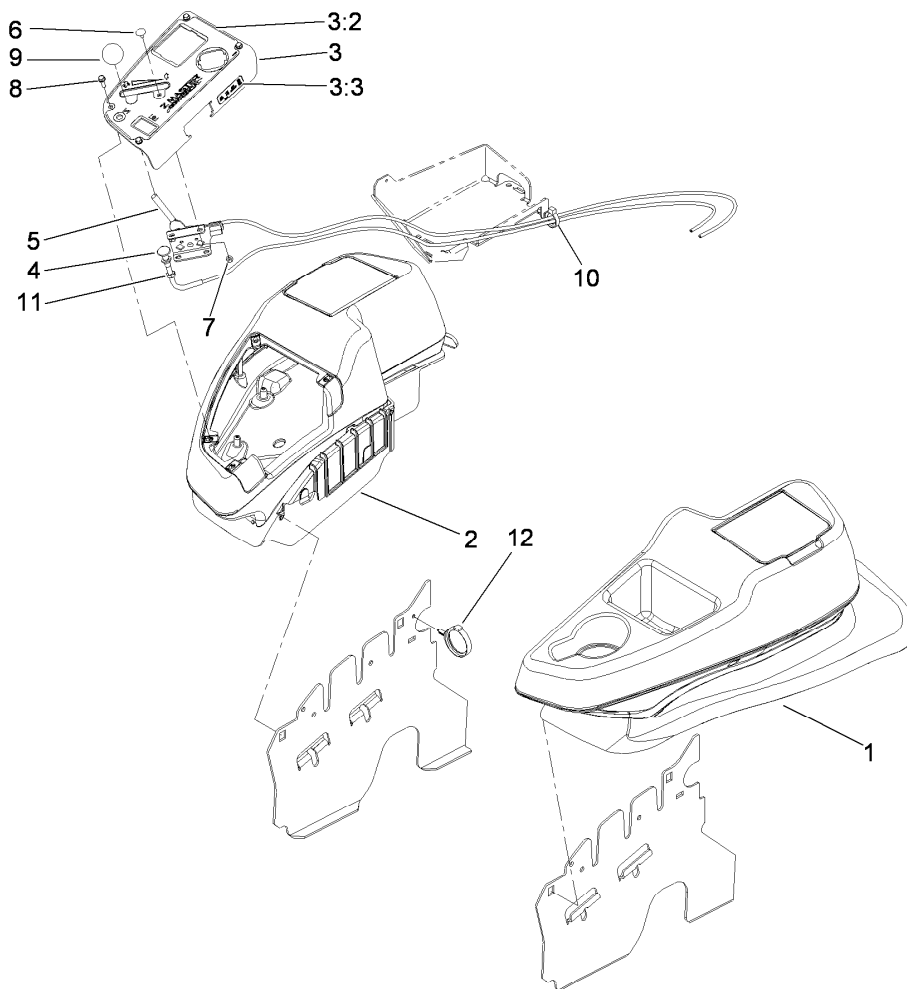

## Fender, Console and Control Assembly

<i>Ref.</i>	<i>Part Number</i>	<i>Qty.</i>	<i>Description</i>
1	115-7401	1	LH Wide Fender/Console ASM
2	115-7400	1	RH Wide Fender/Console ASM
3	114-9836	1	Control Panel ASM
3:2	114-9834	1	Decal-Panel, Control
3:3	114-4466	1	Decal-Fuses
4	115-2753	1	Choke Control ASM
5	110-5727	1	Control-Throttle ASM
6	1-807513	2	Bolt-CARR
7	3296-2	2	Nut-Lock, NI
8	32105-15	4	Screw
9	1-603175	1	Knob-Ball
10	105-1853	1	Clamp-Hose
11	3220-3	1	Nut-HJ
12	117-7817	1	Clamp-Harness

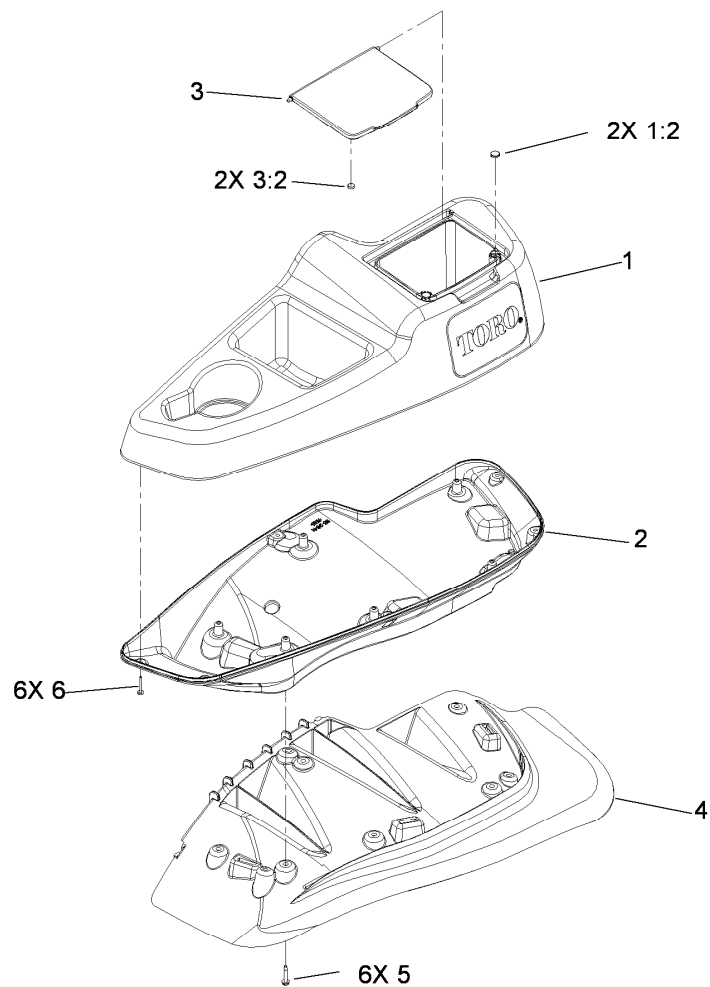

## LH Console Assembly No. 115-7401

<i>Ref.</i>	<i>Part Number</i>	<i>Qty.</i>	<i>Description</i>
1	114-1539	1	LH Wide Console Top ASM
1:2	117-0883	2	Puck
2	115-3641	1	Console-Lwr, LH Wide
3	114-1537	1	Wide Lid ASM
3:2	114-5896	2	Magnet
4	109-9085	1	Fender-Wide, LH
5	32144-89	6	Screw-Thread Forming
6	117-0347	6	Screw-Fillister Head

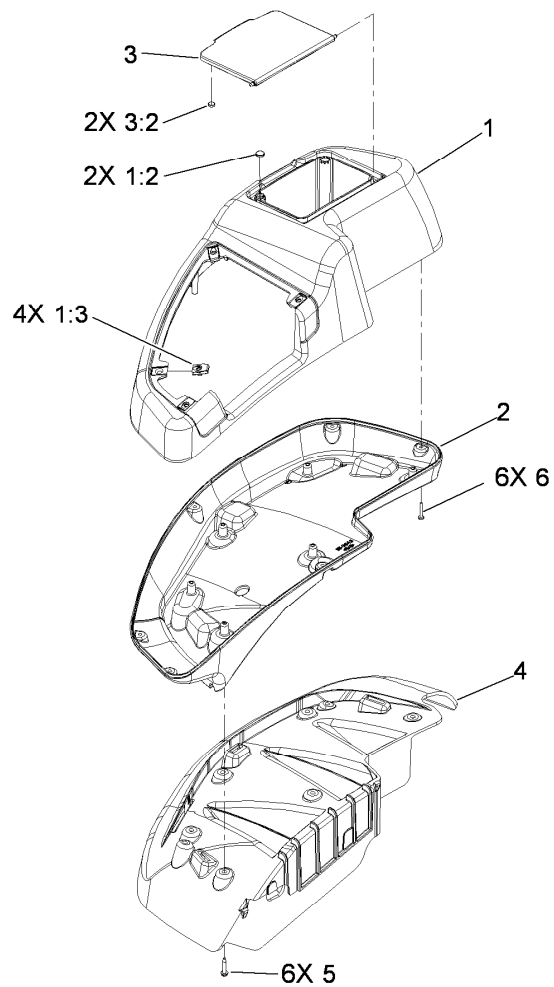

## RH Console Assembly No. 115-7400

<i>Ref.</i>	<i>Part Number</i>	<i>Qty.</i>	<i>Description</i>
1	114-1538	1	RH Wide Top Console ASM
1:2	117-0883	2	Puck
1:3	107069	4	Clip
2	115-3643	1	Console-Lwr, RH Wide
3	114-1537	1	Wide Lid ASM
3:2	114-5896	2	Magnet
4	109-9083	1	Fender-Wide, RH
5	32144-89	6	Screw-Thread Forming
6	117-0347	6	Screw-Fillister Head

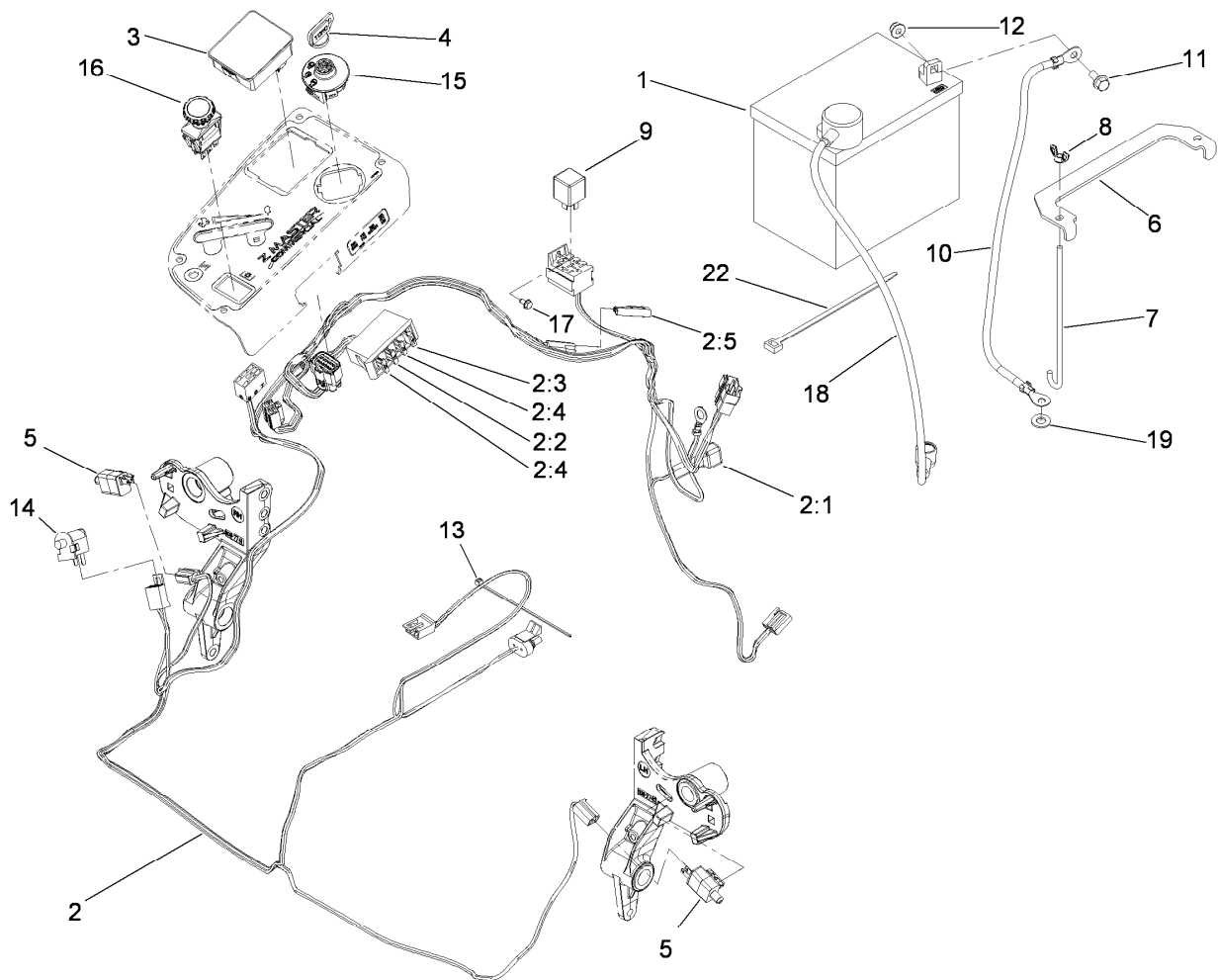

## Electrical System Assembly

<i>Ref.</i>	<i>Part Number</i>	<i>Qty.</i>	<i>Description</i>
1	104-2491	1	Battery
2	115-2796	1	Harness-Wire, Main
2:1	103-3895	1	Diode-Tvs
2:2	218-578	1	Fuse-10 Amp
2:3	109355	1	Fuse-15 Amp
2:4	109102	2	Fuse-25 Amp
2:5	116-0053	1	Cap-Plug
3	116-0916	1	Module-Meter, Hour
4	63-8360	1	Key-Ignition
5	110-6765	2	Switch-Single Pole No
6	116-0042-03	1	Strap-Tie Down, Battery
7	1-633651	2	Bolt-Holddown
8	1-543792	2	Wingnut

<i>Ref.</i>	<i>Part Number</i>	<i>Qty.</i>	<i>Description</i>
9	1-643275	1	Relay
10	114-1218	1	Cable-Battery, Negative
11	3234-5	2	Screw-HHF
12	104-8300	2	Nut-Flange, NI
13	1-303287	3	Tie-Cable
14	82-2190	1	Switch-Bail
15	116-0229	1	Switch-Ignition
16	116-0124	1	Switch-PTO, 10A
17	104-2065	1	Screw-HWH
18	115-3864	1	Cable-Battery, Positive
19	3256-24	1	Washer-Flat
22	1-303335	1	Tie-Plastic

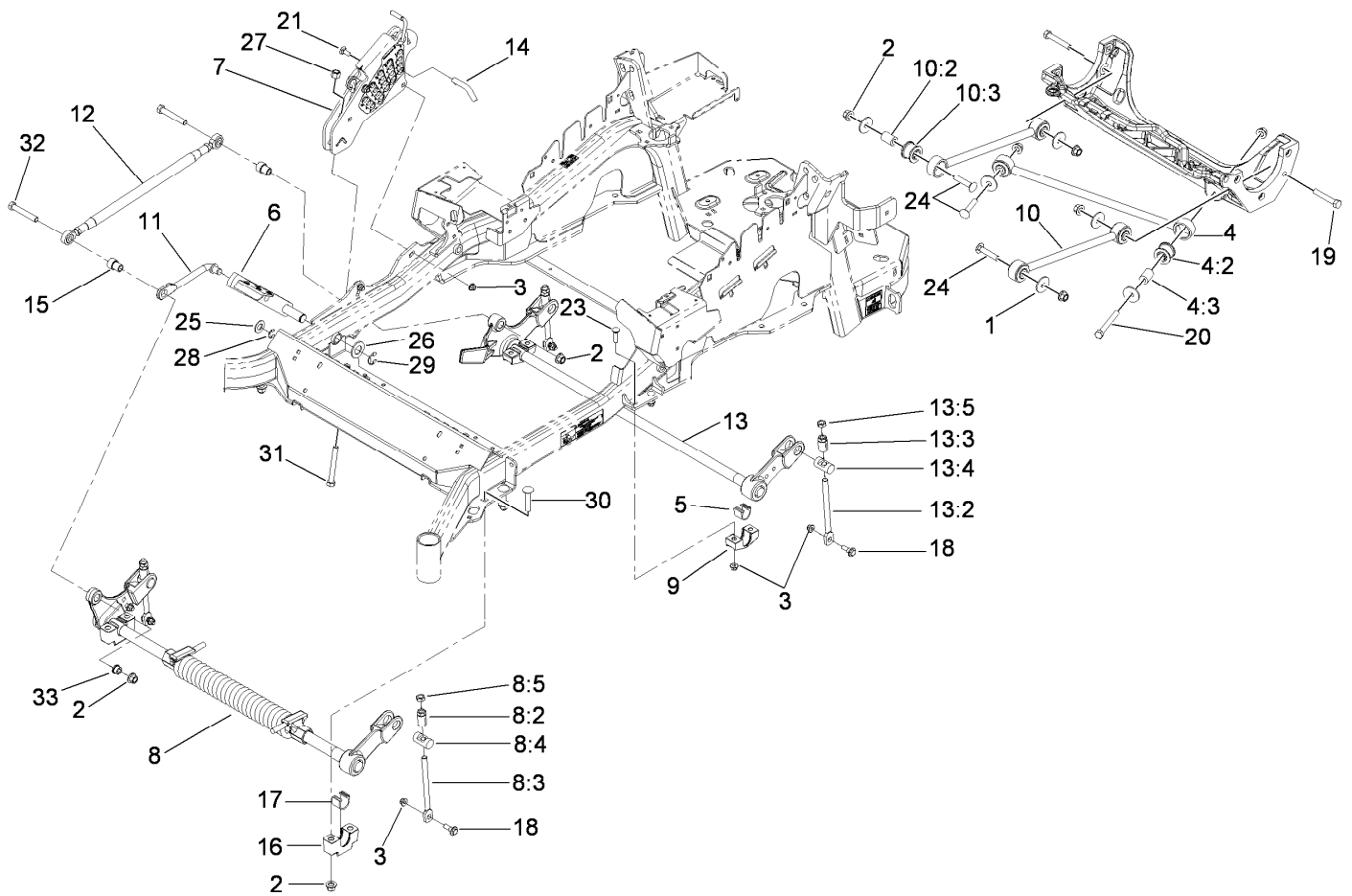

## Deck Lift Assembly

Ref.	Part Number	Qty.	Description	Ref.	Part Number	Qty.	Description
1	86-1990	6	Washer	13:2	109-8007	2	Link-Adjuster, Deck Lift
2	99-5107	12	Nut-Lock	13:3	109-7840	2	Adjuster-Lift, Deck
3	104-8301	10	Nut-Flange, NI	13:4	109-8353	2	Trunnion
4	109-5013	1	Panhard Rod ASM	13:5	3218-5	2	Nut-Jam
4:2	109-5009	2	Bushing-Suspension, Rubber	14	109-8757	1	Pin-HOC
4:3	109-5010	2	Spacer	15	116-0795	2	Bushing-Flange
5	109-7173	2	Bearing-Cross, Rear Shaft	16	109-9409	2	Support-Cross Shaft, Bearing Front
6	109-7202-01	1	Lever-Foot	17	109-9410	2	Bearing-Shaft Front, Cross
7	109-7438	1	Height-Of-Cut ASM	18	109-9840	4	Screw-Shoulder, HHF
8	116-0358	1	Front Deck Lift ASM	19	325-12	2	Screw-HH
8:2	109-7840	2	Adjuster-Lift, Deck	20	325-17	1	Screw-HH
8:3	109-8007	2	Link-Adjuster, Deck Lift	21	3231-2	2	Screw-CARR
8:4	109-8353	2	Trunnion	23	3231-4	4	Screw-CARR
8:5	3218-5	2	Nut-Jam	24	3233-34	3	Screw-CARR
9	109-7171-03	2	Support-Bearing, Cross Shaft	25	3256-27	1	Washer-Flat
10	109-7952	2	Deck Strut ASM	26	3256-29	1	Washer-Flat
10:2	109-5009	2	Bushing-Suspension, Rubber	27	3296-23	1	Nut-Lock, NI
10:3	109-5010	2	Spacer	28	32120-19	1	E-Ring
11	109-8004	1	Link-Lever, Foot	29	32151-103	1	Ring-Retaining, EXT
12	116-0806	1	Side Link ASM	30	3233-37	4	Screw-CARR, Short Neck
13	116-0362	1	Rear Deck Lift ASM	31	116-0559	1	Bolt-TAP
				32	325-13	2	Screw-HH
				33	116-0796	1	Bushing-Flange

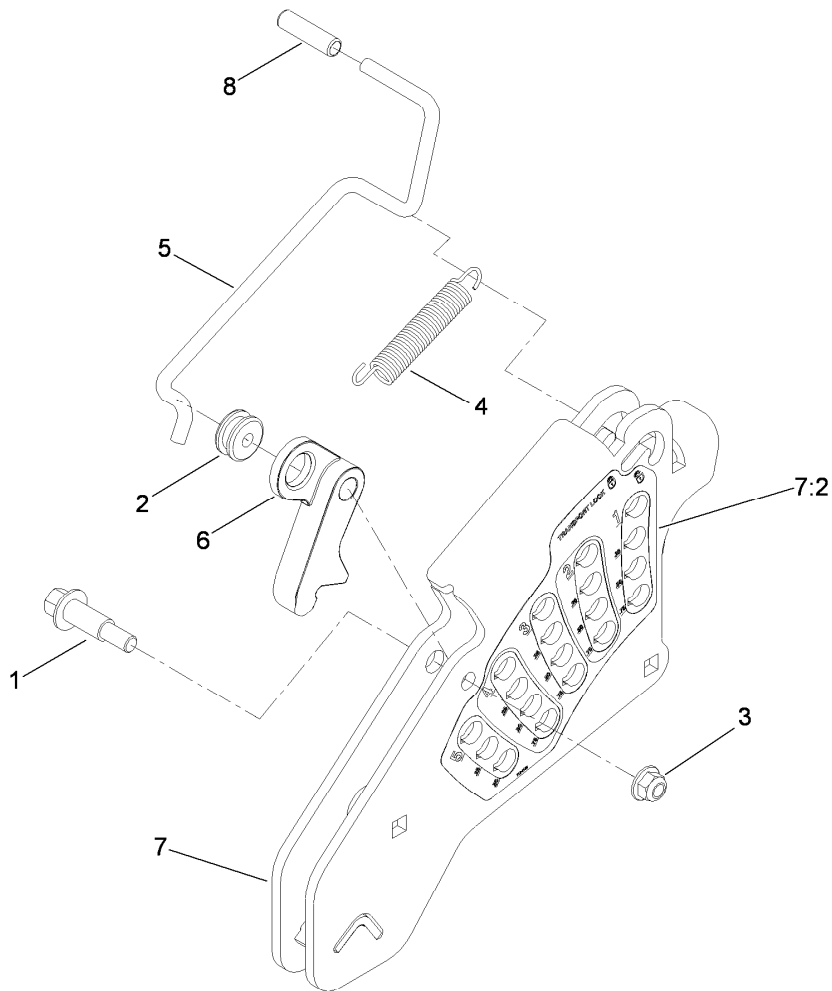

## Height-of-Cut Assembly No. 109-7438

<i>Ref.</i>	<i>Part Number</i>	<i>Qty.</i>	<i>Description</i>
1	62-1330	1	Bolt-Shoulder
2	109-7130	1	Grommet
3	104-8301	1	Nut-Flange, NI
4	109-7124	1	Spring-Extension
5	109-7128	1	Rod-Lock, Transport
6	116-0118	1	Pawl-Transport, HOC
7	109-7335	1	HOC Plate ASM
7:2	116-0752	1	Decal-HOC
8	109-8250	1	Grip-Lever

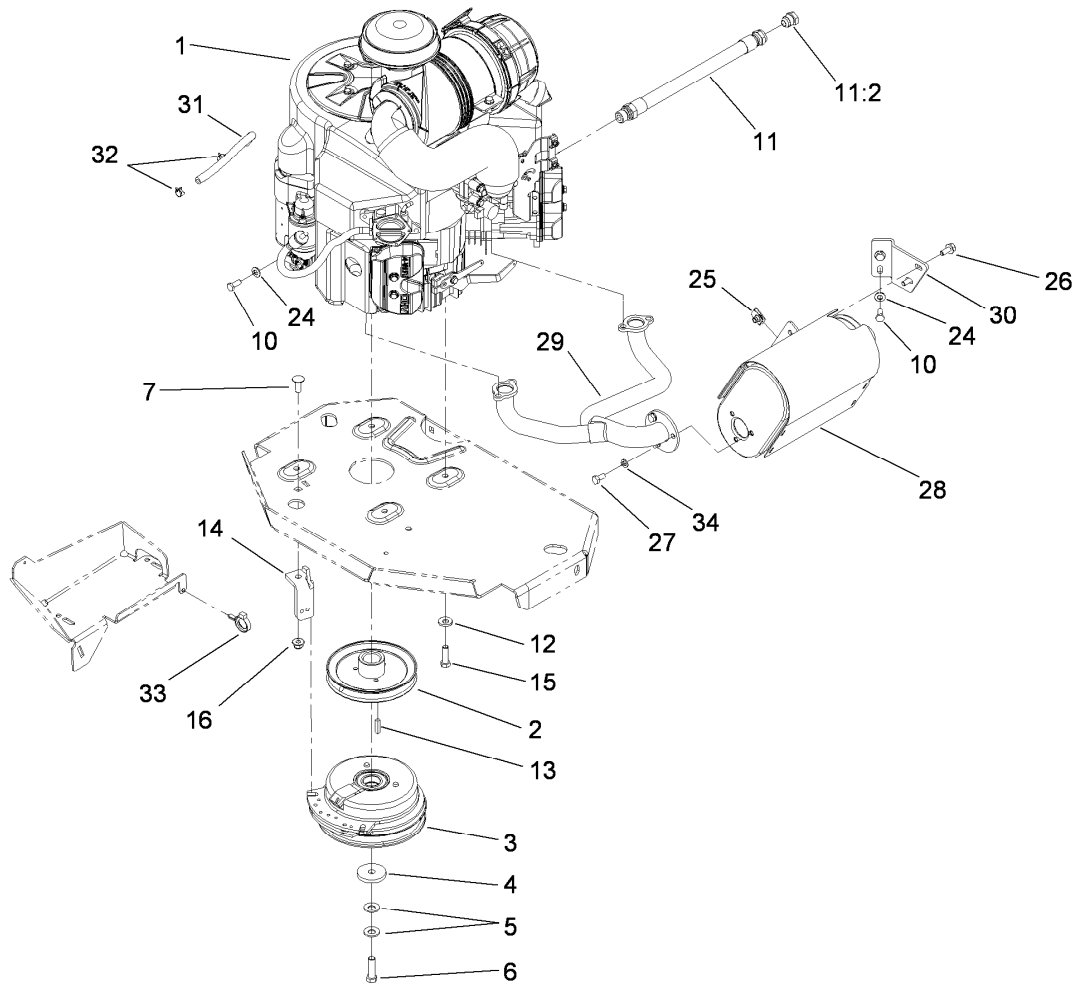

## Engine, Muffler and Clutch Assembly

Ref.	Part Number	Qty.	Description
1		1	Engine-Kawasaki, Fx801V-As04 ●■
2	109-9905	1	Sheave
3	109-9282	1	Clutch
4	109-6919	1	Washer-Clutch
5	1-603610	2	Washer-Spring
6	109-9761	1	Screw-HH W/Loctite
7	3231-22	1	Screw-CARR
10	33114-020	3	Screw-HH
11	109-4490	1	Oil Drain Hose ASM
11:2	109-1012	1	Plug
12	98-5975	4	Washer-Belleville
13	1-807259	1	Key
14	109-8138-01	1	Anchor-Clutch

Ref.	Part Number	Qty.	Description
15	323-7	4	Screw-HH
16	104-8301	1	Nut-Flange, NI
24	1-303334	3	Washer-Spring
25	94-2413	2	U-Nut
26	3234-5	2	Screw-HHF
27	322-2	3	Screw-HH
28	109-9280	1	Muffler-Engine
29	109-9250	1	Manifold-Exhaust
30	116-0203	1	Bracket-Muffler
31	109-0296	1	Hose-Fuel
32	2412-98	2	Clamp
33	105-1853	1	Clamp-Hose
34	3253-4	3	Washer-Lock

● Not serviced separately

■ Obtain parts from [www.kawpowerepc.com](http://www.kawpowerepc.com)



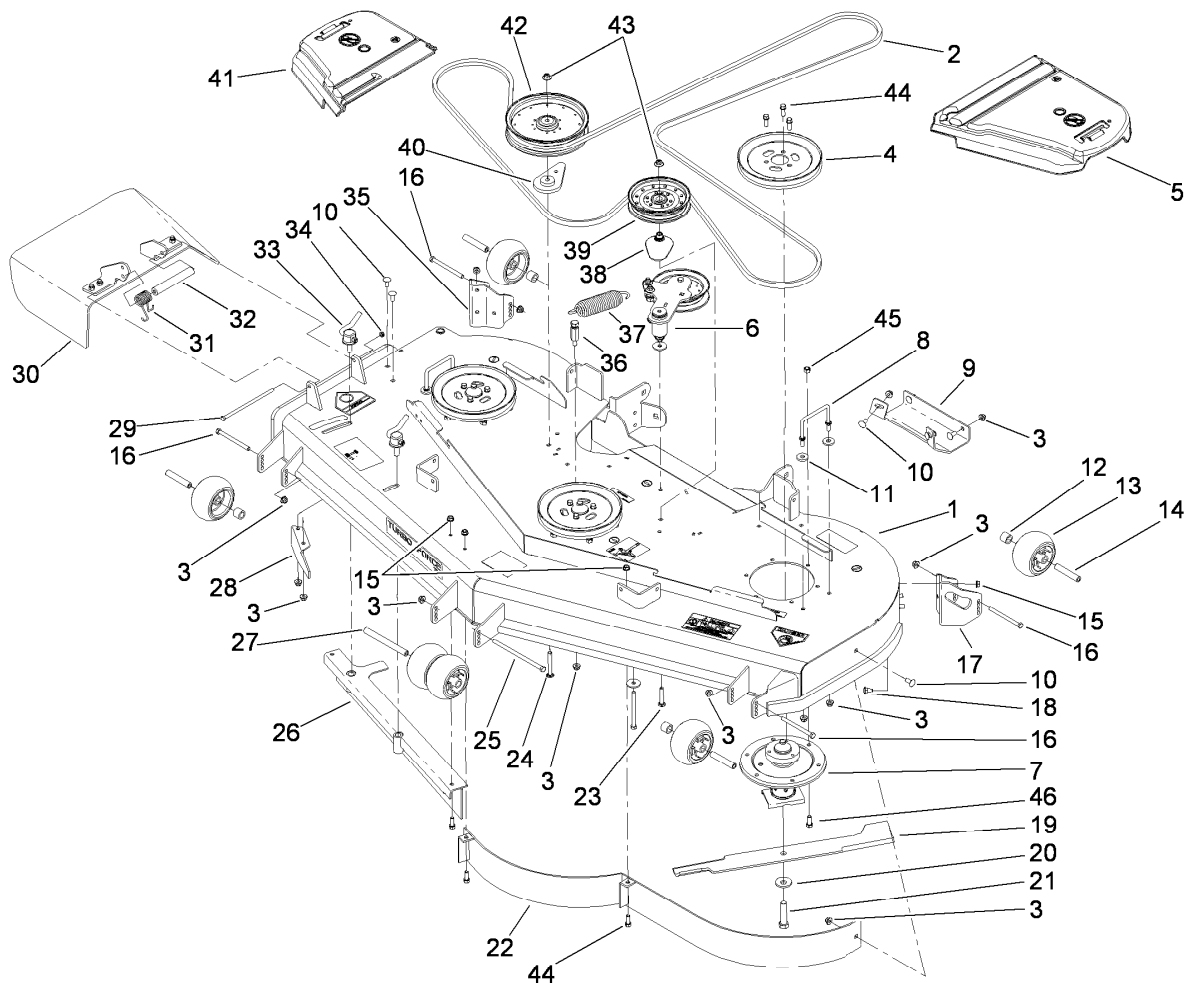

## Deck Assembly

Ref.	Part Number	Qty.	Description	Ref.	Part Number	Qty.	Description
1	112-4195	1	Deck Decal ASM	24	3231-42	1	Screw-CARR
2	114-5859	1	Belt-V	25	108-5388	1	Screw-HH
3	104-8301	17	Nut-Flange, NI	26	105-7669-01	1	Baffle ASM
4	105-7733	3	Pulley	27	98-5967	1	Spacer-Wheel
5	109-6938	1	Cover-Belt, LH	28	106-3216-01	1	Baffle-Discharge
6		1	Arm-Idler ●	29	322-50	1	Screw-HH
7	110-3933	3	Spindle ASM	30	108-2792	1	Rubber Deflector ASM
8	109-6982	2	Wireform-Cover	31	108-4052	1	Spring-Torsion
9	112-4230-01	1	Plate-Skid	32	105-4622	1	Spacer
10	3231-27	7	Screw-CARR	33	107-1664	2	Lever ASM
11	1-373034	4	Washer	34	3296-47	1	Nut-Lock, NI
12	98-7913	4	Tube-Spacer	35	106-7355-01	1	Mount-Wheel, RH
13	1-603299	6	Roller-Scalp, Anti	36	114-5867	1	Anchor-Spring, Tall
14	98-7912	4	Tube-Spanner	37	116-0133	1	Extension-Spring
15	3290-357	9	Nut-HHF, Whiz	38	109-2872	1	Spacer-Pulley
16	323-23	4	Screw-HH	39	114-5895	1	Pulley-Idler, Flat
17	106-7354-01	1	Mount-Wheel, LH	40	109-9416	1	Spacer-Idler
18	3231-1	6	Screw-CARR	41	116-0094	1	Cover-Belt, RH
19	105-7784-03	3	Blade-Hi Flow, 24.5 Inch	42	109-8590	1	Pulley-Idler
20	103-0865	3	Washer-Blade Bolt, Heavy	43	109-6658	2	Nut-Flange, NI
21	103-0862	3	Screw-Cap	44	92-1624	12	Screw-HWH
22	114-5843-01	1	Baffle ASM	45	33025-00	18	Nut-Lock
23	3231-40	1	Bolt-CARR	46	33115-025	18	Screw-HH

● Not serviced separately

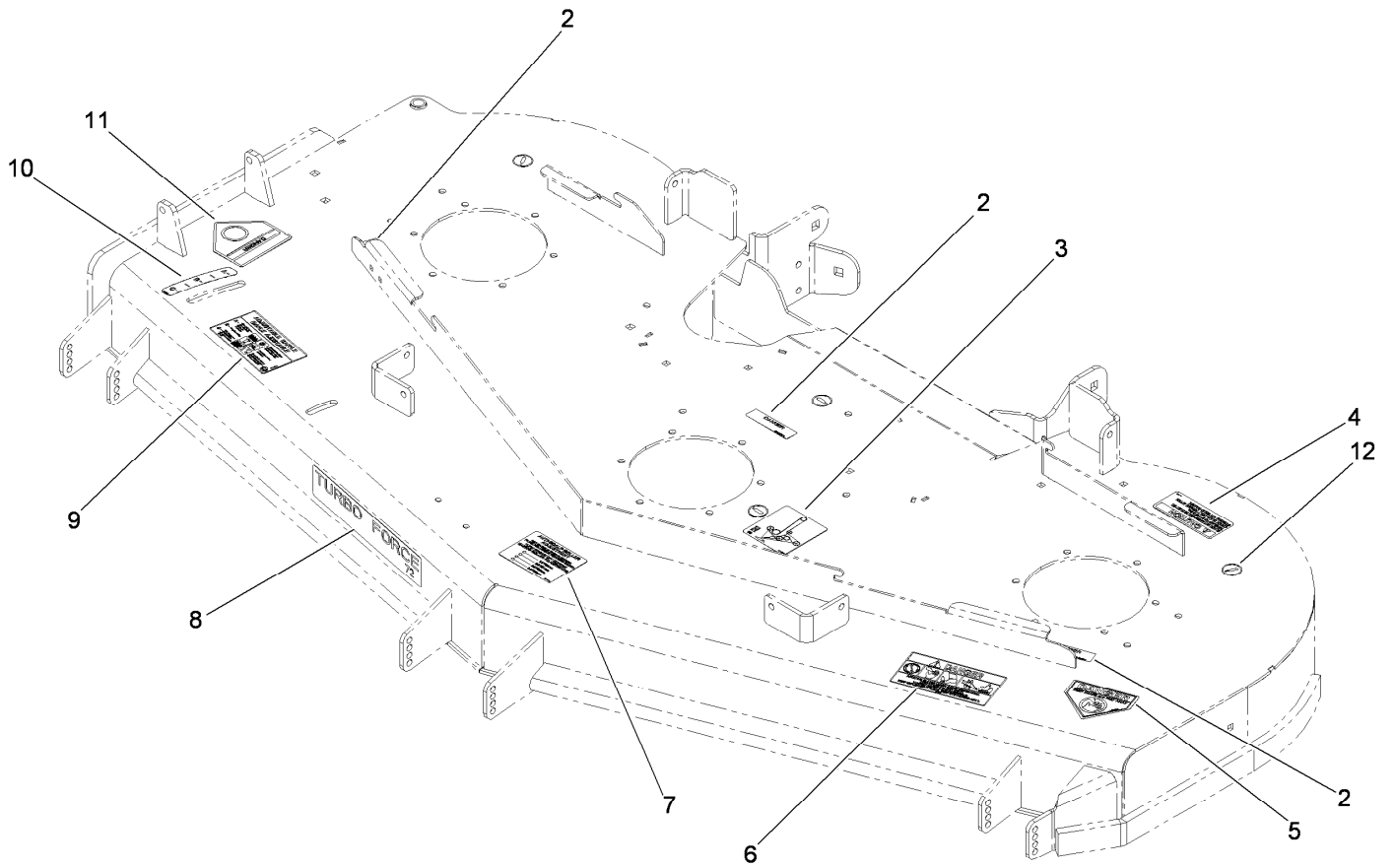

## Deck Decal Assembly No. 112-4195

<i>Ref.</i>	<i>Part Number</i>	<i>Qty.</i>	<i>Description</i>
2	98-5954	3	Decal-Cover, Missing
3	115-7445	1	Decal-Routing, Deck Belt
4	68-8340	1	Decal-Torque
5	1-403005	1	Decal-Danger
6	66-1340	1	Decal-Danger, Thrown Object
7	105-7798	1	Decal-Scalp, Anti
8	107-1620	1	Decal
9	110-2068	1	Decal-Adjustment, Baffle
10	110-2067	1	Decal-Setting, Baffle
11	54-9220	1	Decal-Danger
12	58-6520	4	Decal-Grease

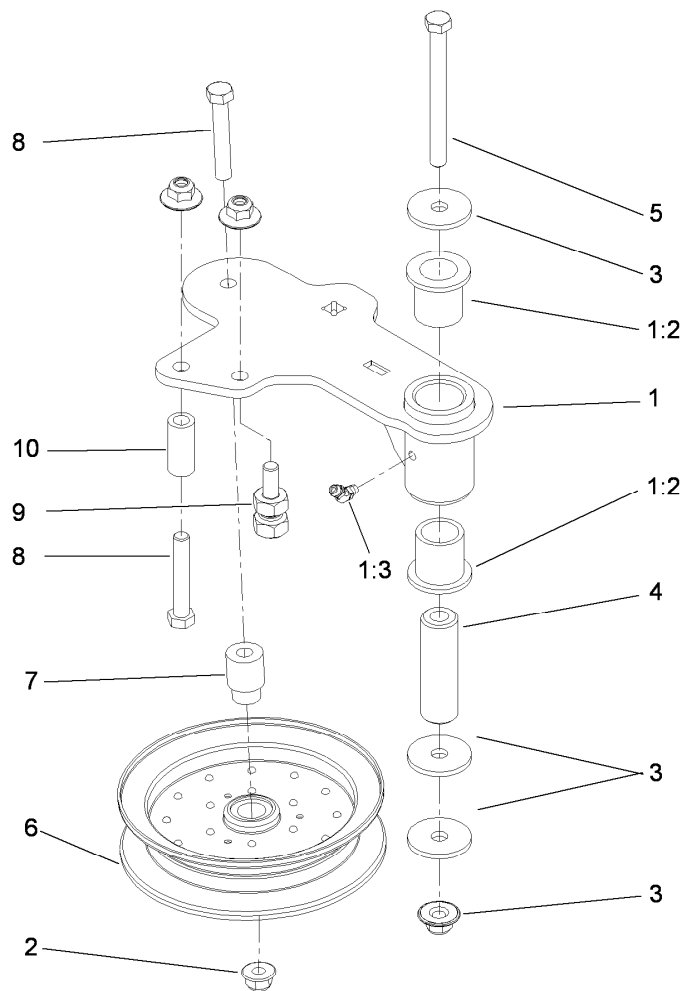

## Idler Assembly

<i>Ref.</i>	<i>Part Number</i>	<i>Qty.</i>	<i>Description</i>
1	114-5870	1	Idler Arm ASM
1:2	1-303514	2	Bearing-Flanged
1:3	1481	1	Fitting-Grease
2	109-6658	4	Nut-Flange, NI
3	1-213069	3	Washer
4	114-5848	1	Spacer-Plain
5	98-5961	1	Screw-HH
6	103-8743	1	Pulley-Idler, Flanged
7	112-4212	1	Mount-Pulley
8	323-11	2	Screw-HH
9	114-5866	1	Anchor-Spring, Short
10	104-0151	1	Spacer

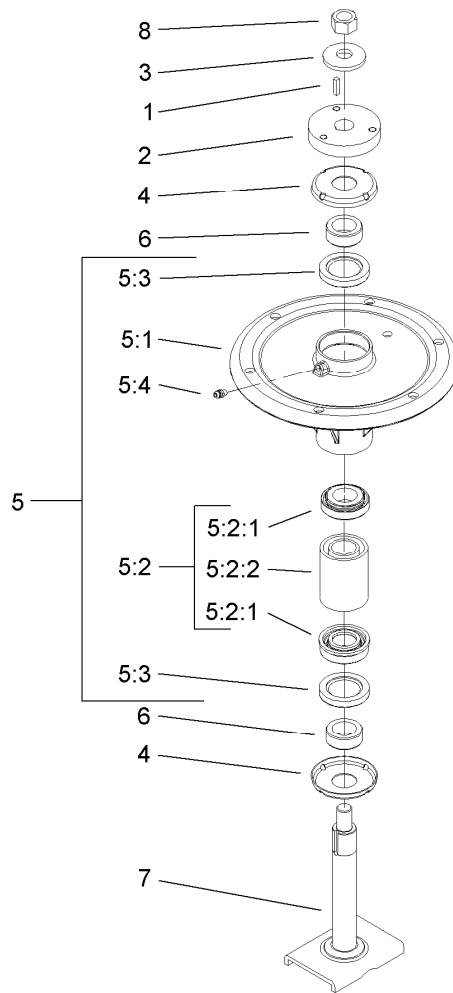

## Spindle Assembly No. 110-3933

<i>Ref.</i>	<i>Part Number</i>	<i>Qty.</i>	<i>Description</i>
1	10-8040	1	Key-Square
2	108-7793	1	Hub-Pulley
3	103-0865	1	Washer-Blade Bolt, Heavy
4	106-3204	2	Shield-Bearing
5		1	Spindle Bearing ASM ●
5:1	106-3211	1	Housing-Spindle
5:2	108-7711	1	Bearing ASM
5:2:1	108-7710	1	Bearing ASM
5:2:2	106-3206	1	Spacer (Matched Set)
5:3	253-133	2	Seal-Oil
5:4	302-5	1	Fitting-Grease
6	106-3218	2	Spacer-Seal
7	106-3233	1	Spindle Shaft ASM
8	3219-6	1	Nut-Hex

● Not serviced separately

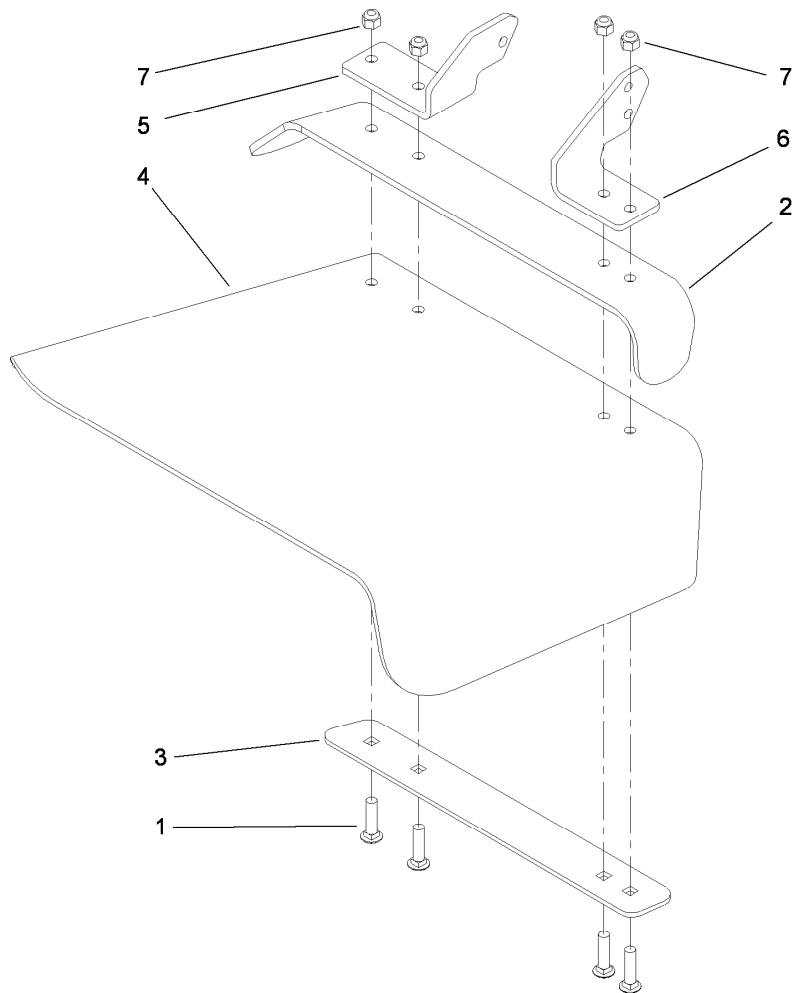

## Rubber Deflector Assembly No. 108-2792

<i>Ref.</i>	<i>Part Number</i>	<i>Qty.</i>	<i>Description</i>
1	3231-4	4	Screw-CARR
2	106-3246-01	1	Deflector
3	106-3248-03	1	Strap-Discharge
4	108-5029	1	Deflector-Rubber
5	108-4059-01	1	Plate-Hinge, Rear
6	106-3253-01	1	Plate-Hinge, Front
7	3296-39	4	Nut-Lock, NI

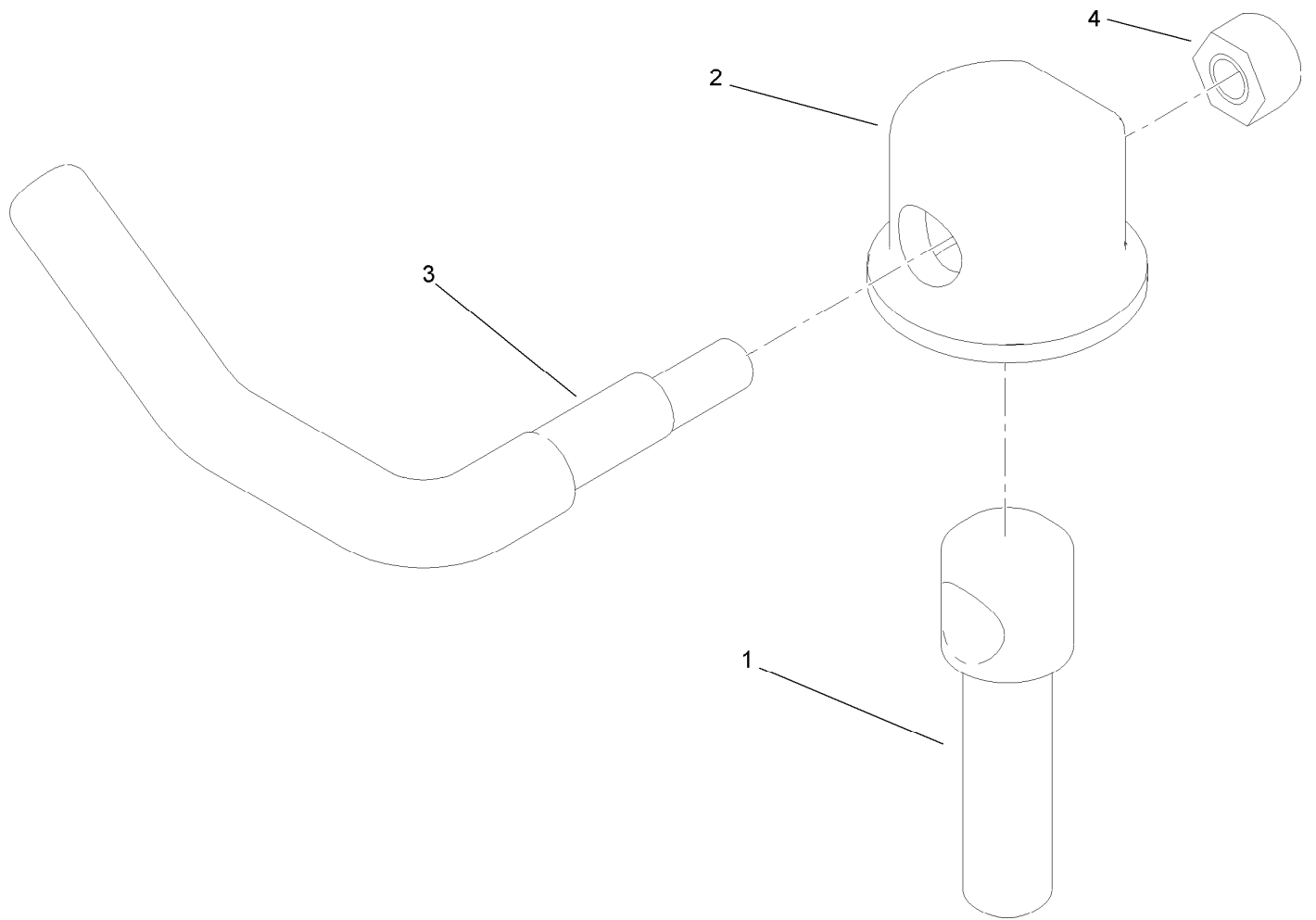

## Lever Assembly No. 107-1664

<i>Ref.</i>	<i>Part Number</i>	<i>Qty.</i>	<i>Description</i>
1	106-3239	1	Screw-Lock
2	107-1644	1	Cap-Lock
3	106-3241	1	Lever-Lock
4	3296-29	1	Nut-Lock, NI

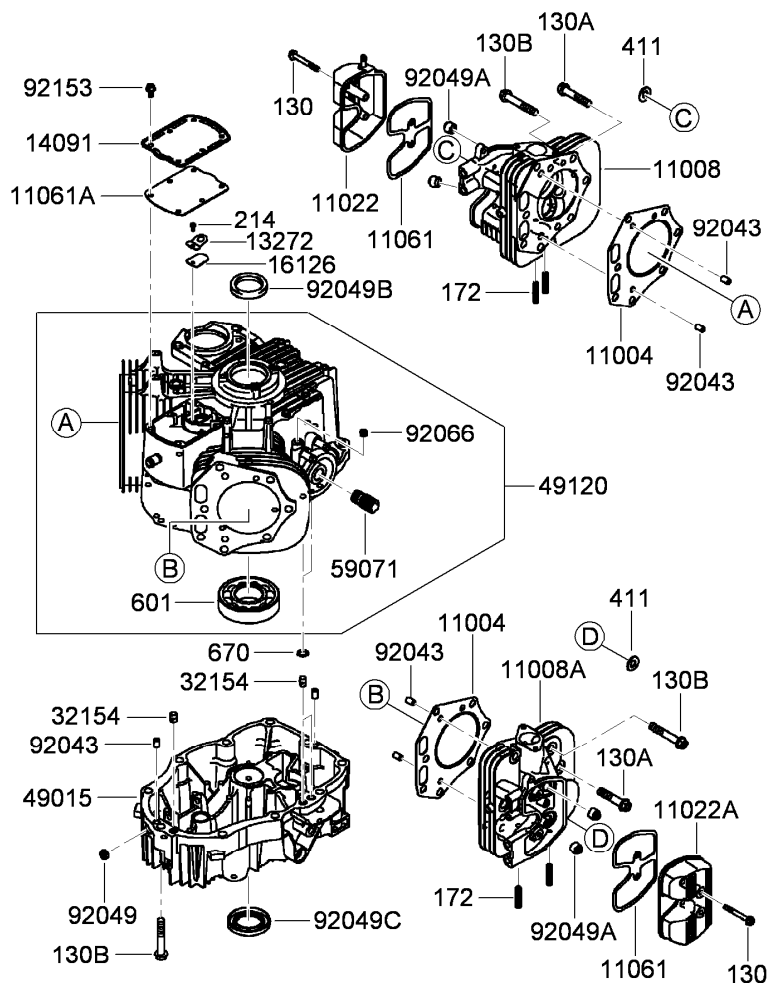

## Cylinder and Crankcase Assembly Kawasaki FX801V-AS04

Ref.	Part Number	Qty.	Description	Ref.	Part Number	Qty.	Description
130	130AA0650	4	Bolt-Flanged (6X50) ●	14091	14091-7060	1	Cover-Breather ●
130A	130CA1050	2	Bolt-Flanged (10X50) ●	16126	16126-7020	1	Valve-Breather ●
130B	130CA1060	20	Bolt-Flanged (10X60) ●	32154	32154-7019	3	Pipe ●
172	172BA0818	4	Bolt-Stud (8X18) ●	49015	49015-7088	1	Cover-Crankcase ●
214	214AA0408	1	Screw-Pan +-(4X8) ●	49120	49120-7117	1	Crankcase ●
411	411AA1000	2	Washer-Plain (10Mm) ●	59071	59071-2079	1	Joint ●
601	601A6308	1	Bearing-Ball ●	92043	92043-7024	6	Pin ●
670	670B2011	2	O-Ring (11Mm) ●	92049	92049-7005	1	Seal-Oil, S O (8X14X5 H S) ●
11004	11004-7025	2	Gasket-Head ●	92049A	92049-7020	4	Seal-Oil (7X15X13) ●
11008	11008-7036	1	Head-Cylinder, No.1 ●	92049B	92049-7024	1	Seal-Oil, S D (40X54X9 R Hs) ●
11008A	11008-7037	1	Head-Cylinder, No.2 ●	92049C	92049-7026	1	Seal-Oil, S D (40X62X8 L Vs) ●
11022	11022-6007	1	Case-Rocker, No.1 ●	92066	92066-7026	1	Plug ●
11022A	11022-7016	1	Case-Rocker, No.2 ●	92153	92153-7043	6	Bolt (6X12) ●
11061	11061-7080	2	Gasket-Case, Rocker ●				
11061A	11061-7081	1	Gasket-Breather ●				
13272	13272-7004	1	Plate-Breather ●				

● Obtain parts from [www.kawpowerepc.com](http://www.kawpowerepc.com)

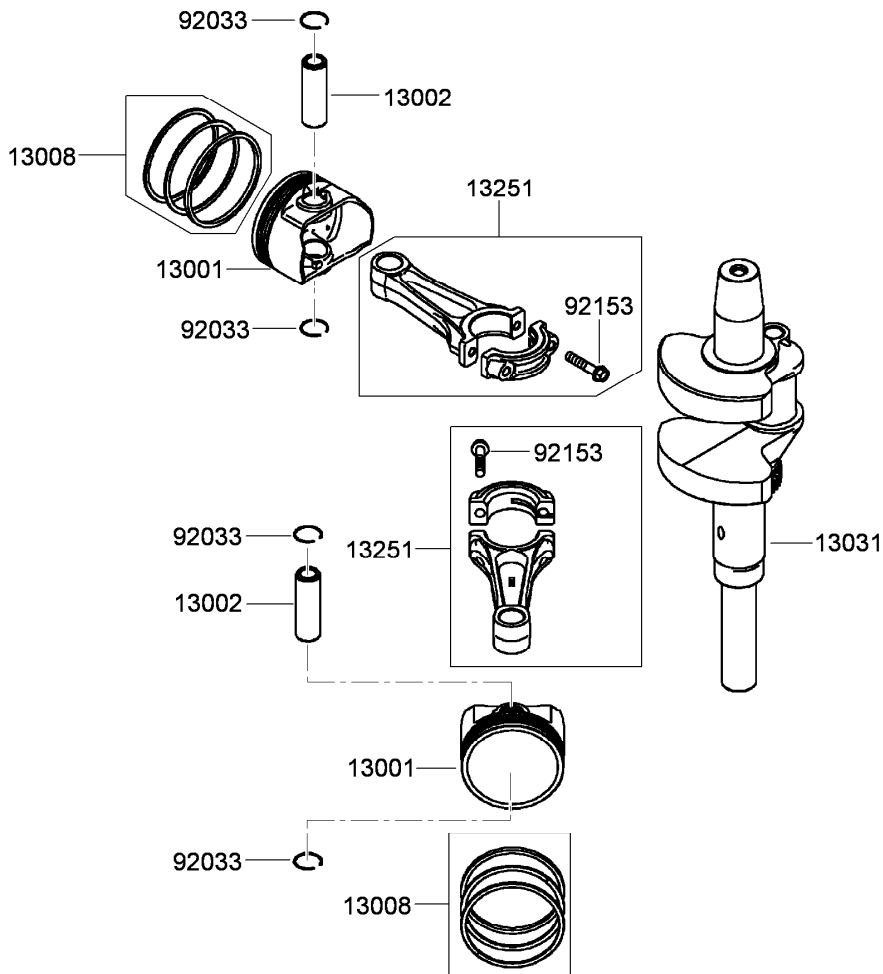

## Piston and Crankshaft Assembly Kawasaki FX801V-AS04

<i>Ref.</i>	<i>Part Number</i>	<i>Qty.</i>	<i>Description</i>
13001	13001-7025	2	Piston-Engine ●
13002	13002-7005	2	Pin-Piston ●
13008	13008-6069	2	Piston Ring Set ●
13031	13031-7079	1	Crankshaft ●
13251	13251-7019	2	Connecting Rod ASM ●
92033	92033-7013	4	Ring-Snap ●
92153	92153-2054	4	Bolt (7X35.2) ●

● Obtain parts from [www.kawpowerepc.com](http://www.kawpowerepc.com)



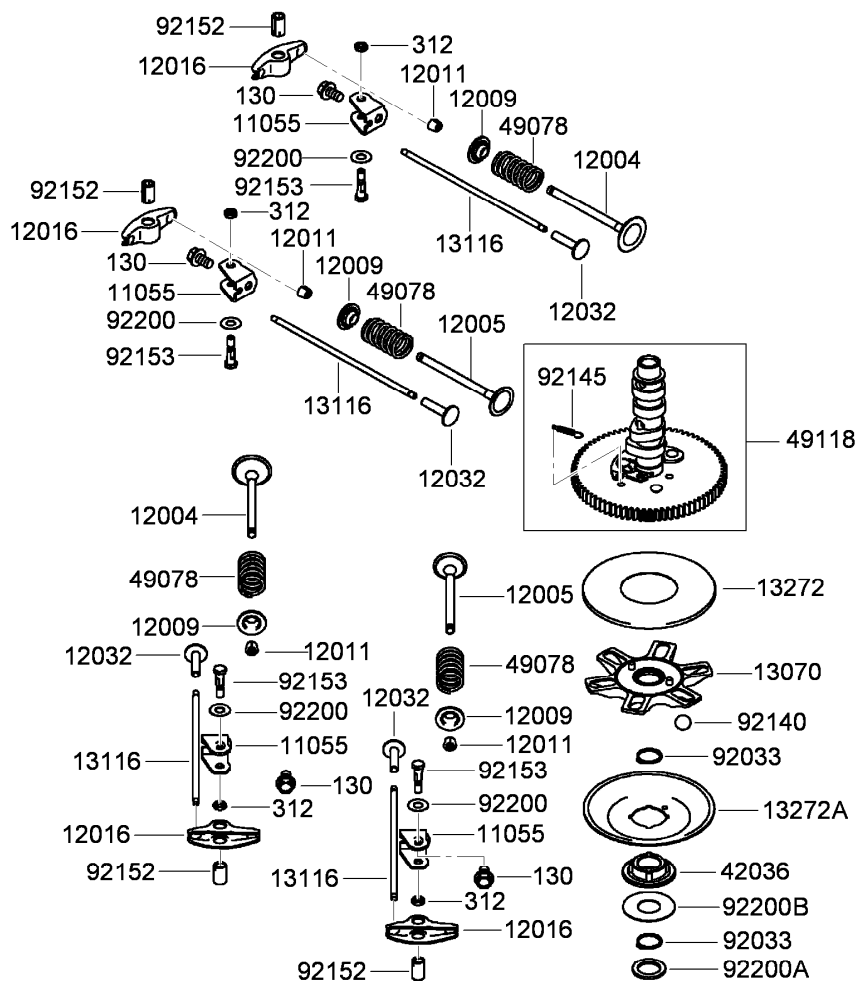

## Valve and Camshaft Assembly Kawasaki FX801V-AS04

Ref.	Part Number	Qty.	Description
130	130AA0814	4	Bolt-Flanged (8X14) ●
312	312AA0600	4	Nut-Hex (6Mm) ●
11055	11055-7009	4	Bracket ●
12004	12004-7007	2	Valve-Intake ●
12005	12005-7008	2	Valve-Exhaust ●
12009	12009-7002	4	Retainer-Spring, Valve ●
12011	12011-2052	8	Collet ●
12016	12016-7016	4	Arm-Rocker ●
12032	12032-7001	4	Tappet ●
13070	13070-7016	1	Guide ●
13116	13116-7006	4	Rod-Push ●
13272	13272-7002	1	Plate ●
13272A	13272-7003	1	Plate-Governor ●
42036	42036-7019	1	Sleeve ●
49078	49078-7005	4	Spring-Valve, Engine ●
49118	49118-7021	1	Camshaft ●
92033	92033-7012	2	Ring-Snap (Dia 18.5) ●
92140	92140-7005	6	Ball ●
92145	92145-7001	1	Spring ●
92152	92152-7012	4	Collar ●
92153	92153-7100	4	Bolt (6X29.5) ●
92200	92200-2151	4	Washer (8.1X18X0.5) ●
92200A	92200-7044	1	Washer (20.3X29X2.28) ●
92200B	92200-7045	1	Washer (20X46X0.91) ●

● Obtain parts from [www.kawpowerepc.com](http://www.kawpowerepc.com)

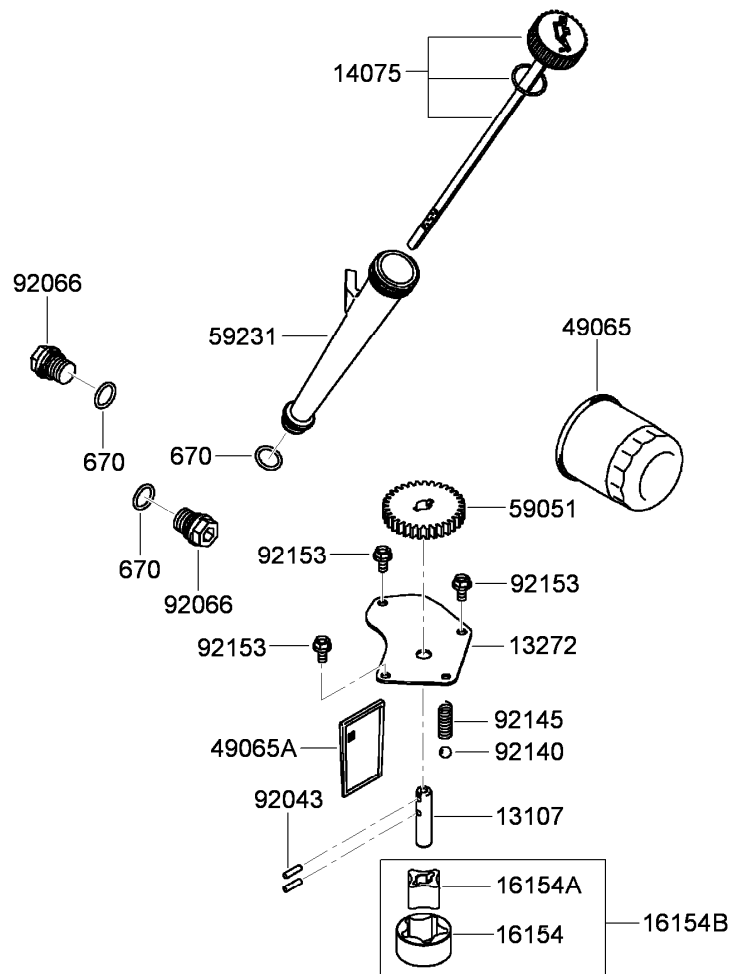

## Lubrication Equipment Assembly Kawasaki FX801V-AS04

Ref.	Part Number	Qty.	Description
670	670D2016	3	O-Ring (16Mm) ●
13107	13107-7009	1	Shaft ●
13272	13272-7005	1	Plate ●
14075	14075-7012	1	Cap ASM ●
16154	16154-1075	1	Rotor-Pump, Outer ●
16154A	16154-1076	1	Rotor-Pump, Inner ●
16154B	16154-1079	1	Rotor-Pump ●
49065	49065-2078	1	Filter-Oil ●
49065A	49065-7004	1	Filter-Oil ●
59051	59051-7011	1	Gear-Spur ●
59231	59231-7014	1	Filler ●
92043	92043-7003	2	Pin ●
92066	92066-7003	2	Plug ●
92140	92140-7003	1	Ball ●
92145	92145-7002	1	Spring ●
92153	92153-7043	3	Bolt (6X12) ●

● Obtain parts from [www.kawpowerepc.com](http://www.kawpowerepc.com)

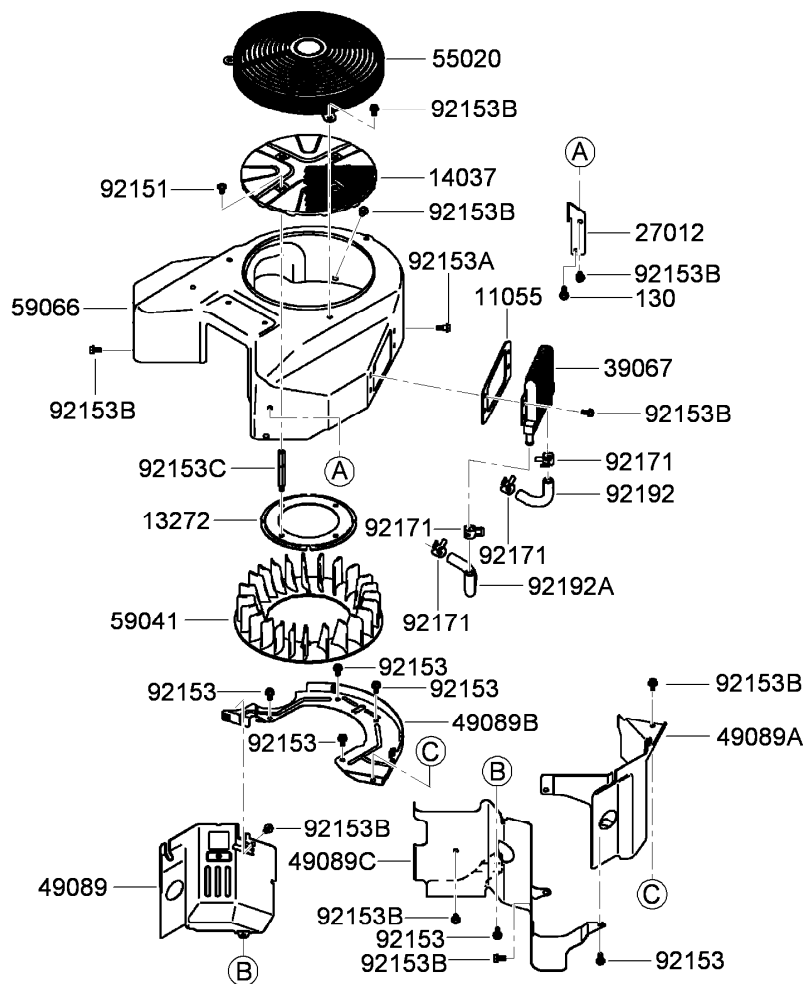

## Cooling Equipment Assembly Kawasaki FX801V-AS04

Ref.	Part Number	Qty.	Description
130	130AA0620	1	Bolt-Flanged (6X20) ●
11055	11055-7005	1	Bracket ●
13272	13272-7006	1	Plate-Fan ●
14037	14037-7029-9H	1	Screen ●
27012	27012-7006	1	Hook-Lift ●
39067	39067-7007	1	Cooler-Oil ●
49089	49089-7064-753	1	Shroud-Engine, No.1 ●
49089A	49089-7065-753	1	Shroud-Engine, No.2 ●
49089B	49089-7066	1	Shroud-Engine, Rear ●
49089C	49089-7067-753	1	Shroud-Engine, V-Bank ●
55020	55020-7016-9H	1	Guard ●
59041	59041-7013	1	Fan ●
59066	59066-7042-753	1	Housing-Fan ●
92151	92151-7012	4	Bolt (6X12) ●
92153	92153-0010	6	Bolt ●
92153A	92153-7007	1	Bolt ●
92153B	92153-7043	14	Bolt (6X12) ●
92153C	92153-7101	4	Bolt ●
92171	92171-7015	4	Clamp ●
92192	92192-7089	1	Tube ●
92192A	92192-7090	1	Tube ●

● Obtain parts from [www.kawpowerepc.com](http://www.kawpowerepc.com)

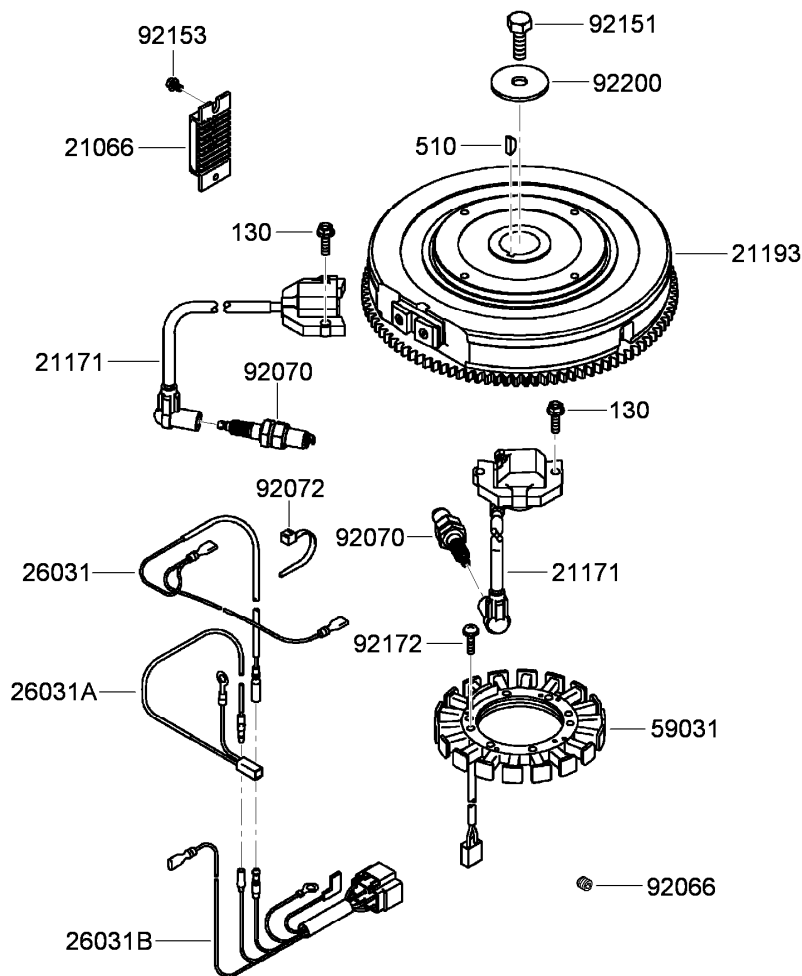

## Electric Equipment Assembly Kawasaki FX801V-AS04

<i>Ref.</i>	<i>Part Number</i>	<i>Qty.</i>	<i>Description</i>
130	130AA0620	4	Bolt-Flanged (6X20) ●
510	510A5100	1	Key-Woodruff ●
21066	21066-7011	1	Regulator-Voltage ●
21171	21171-7036	2	Ignition Coil ASM ●
21193	21193-7035	1	Flywheel ASM ●
26031	26031-7033	1	Harness ●
26031A	26031-7034	1	Harness ●
26031B	26031-7039	1	Harness ●
59031	59031-7017	1	Coil-Charging ●
92066	92066-7026	1	Plug ●
92070	92070-7004	2	Sparkplug (B P R4 E S (N G K) Solid) ●
92072	92072-7003	3	Band ●
92151	92151-2097	1	Bolt (12X30) ●
92153	92153-7029	2	Bolt ●
92172	92172-7018	4	Screw (5X20) ●
92200	92200-7040	1	Washer (12.2X46X3) ●

● Obtain parts from [www.kawpowerepc.com](http://www.kawpowerepc.com)

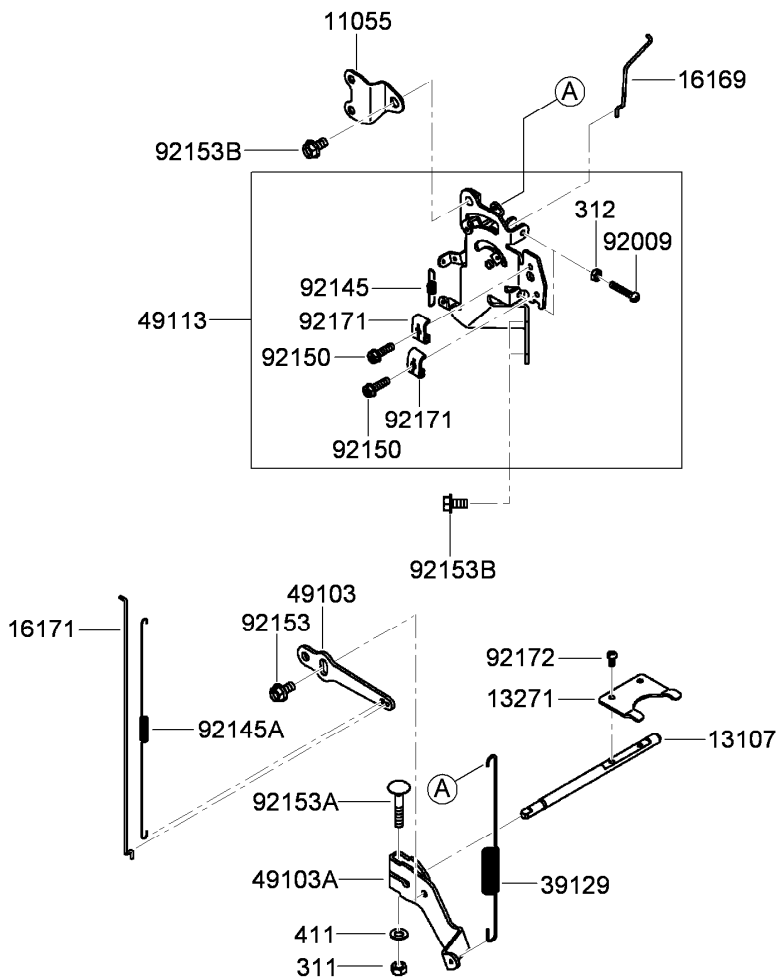

## Control Equipment Assembly Kawasaki FX801V-AS04

Ref.	Part Number	Qty.	Description
311	311AA0600	1	Nut-Hex (6Mm) ●
312	312AA0500	2	Nut-Hex (5Mm) ●
411	411AA0600	1	Washer-Plain (6Mm) ●
11055	11055-7001	1	Bracket ●
13107	13107-7044	1	Shaft-Governor ●
13271	13271-7038	1	Plate ●
16169	16169-7019	1	Link-Choke ●
16171	16171-7020	1	Link ●
39129	39129-7020	1	Spring-Governor ●
49103	49103-7012	1	Arm-Governor ●
49103A	49103-7013	1	Arm-Governor ●
49113	49113-7046	1	Panel-Control ●
92009	92009-2381	2	Screw (5X30) ●
92145	92145-7044	1	Spring ●
92145A	92145-7055	1	Spring ●
92150	92150-2182	2	Bolt (5X18) ●
92153	92153-0009	1	Bolt (6X12) ●
92153A	92153-7033	1	Bolt (6X35) ●
92153B	92153-7043	3	Bolt (6X12) ●
92171	92171-7018	2	Clamp ●
92172	92172-7033	2	Screw (4X8) ●

● Obtain parts from [www.kawpowerepc.com](http://www.kawpowerepc.com)

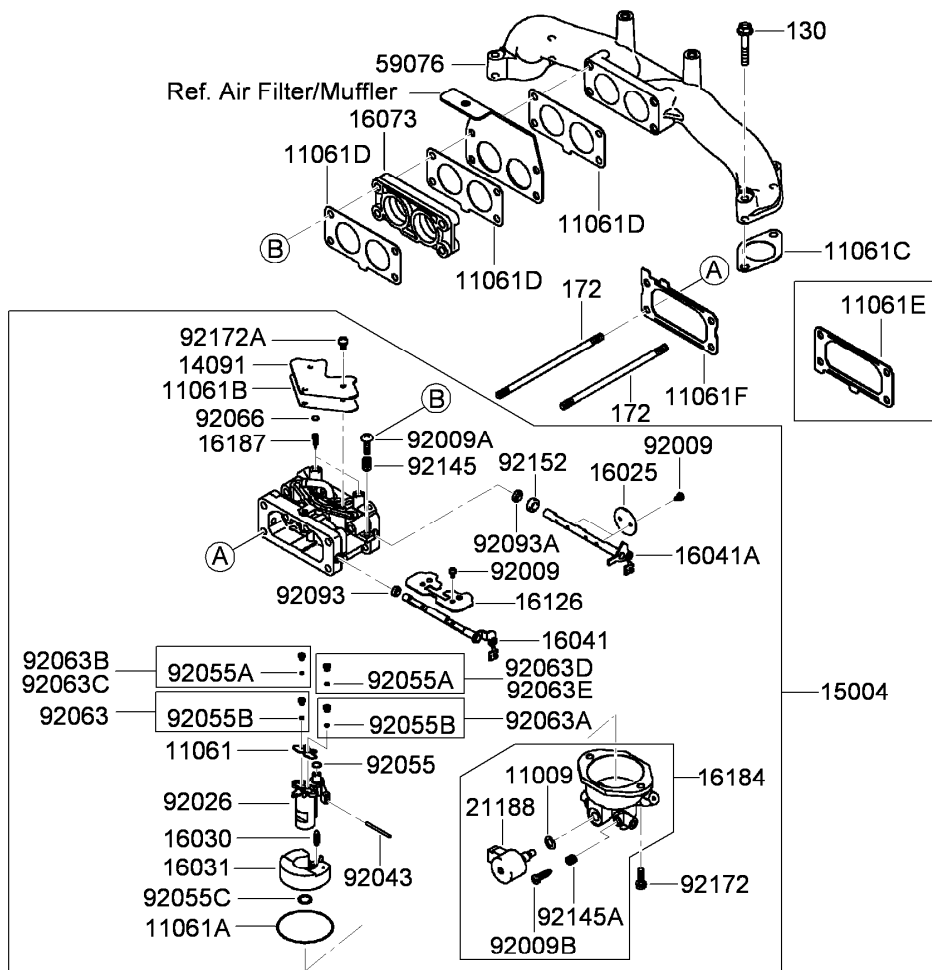

## Carburetor Assembly Kawasaki FX801V-AS04

Ref.	Part Number	Qty.	Description	Ref.	Part Number	Qty.	Description
130	130AA0635	4	Bolt-Flanged (6X35) ●	16184	16184-7021	1	Float Chamber ASM ●
172	172BA06120	2	Bolt-Stud (6X120) ●	16187	16187-7005	2	Needle-Jet ●
11009	11009-2056	1	Gasket ●	21188	21188-7003	1	Solenoid ●
11061	11061-7037	1	Gasket ●	59076	59076-7013	1	Manifold-Intake ●
11061A	11061-7038	1	Gasket ●	92009	92009-7003	6	Screw ●
11061B	11061-7039	1	Gasket ●	92009A	92009-7004	1	Screw ●
11061C	11061-7070	2	Gasket (Head To Manifold) ●	92009B	92009-7006	1	Screw-Drain ●
11061D	11061-7072	3	Gasket (Carburetor To Manifold) ●	92026	92026-7024	1	Spacer ●
11061E	11061-7078	1	Gasket (Carburetor To Pipe) (This Part May Be Used As Substitute For 11061-7091) ●	92043	92043-7014	1	Pin ●
11061F	11061-7091	1	Gasket (Carburetor To Pipe) ●	92055	92055-7012	1	O-Ring ●
14091	14091-7031	1	Cover ●	92055A	92055-7013	1	O-Ring ●
15004	15004-7044	1	Carburetor ASM ●	92055B	92055-7013	2	O-Ring ●
16025	16025-7010	2	Valve-Throttle ●	92055C	92055-7016	1	O-Ring ●
16030	16030-7004	1	Valve-Float ●	92063	92063-7110	1	Jet-Main, No.118 ●
16031	16031-7003	1	Float ●	92063A	92063-7111	1	Jet-Main, No.120 ●
16041	16041-7039	1	Shaft-Carburetor ●	92063B	92063-7135	1	Jet-Main, No.115 (3280 Ft) ●
16041A	16041-7042	1	Shaft-Carburetor ●	92063C	92063-7136	1	Jet-Main, No.112 (6560 Ft) ●
16073	16073-7011	1	Insulator ●	92063D	92063-7137	1	Jet-Main, No.117 (3280 Ft) ●
16126	16126-7021	1	Valve ●	92063E	92063-7138	1	Jet-Main, No.114 (6560 Ft) ●
				92066	92066-7009	2	Plug-Expansion ●
				92093	92093-7001	1	Seal (I D 5.9) ●
				92093A	92093-7002	1	Seal (I D 6.9) ●
				92145	92145-7010	1	Spring ●
				92145A	92145-7011	1	Spring ●

● Obtain parts from [www.kawpowerepc.com](http://www.kawpowerepc.com)

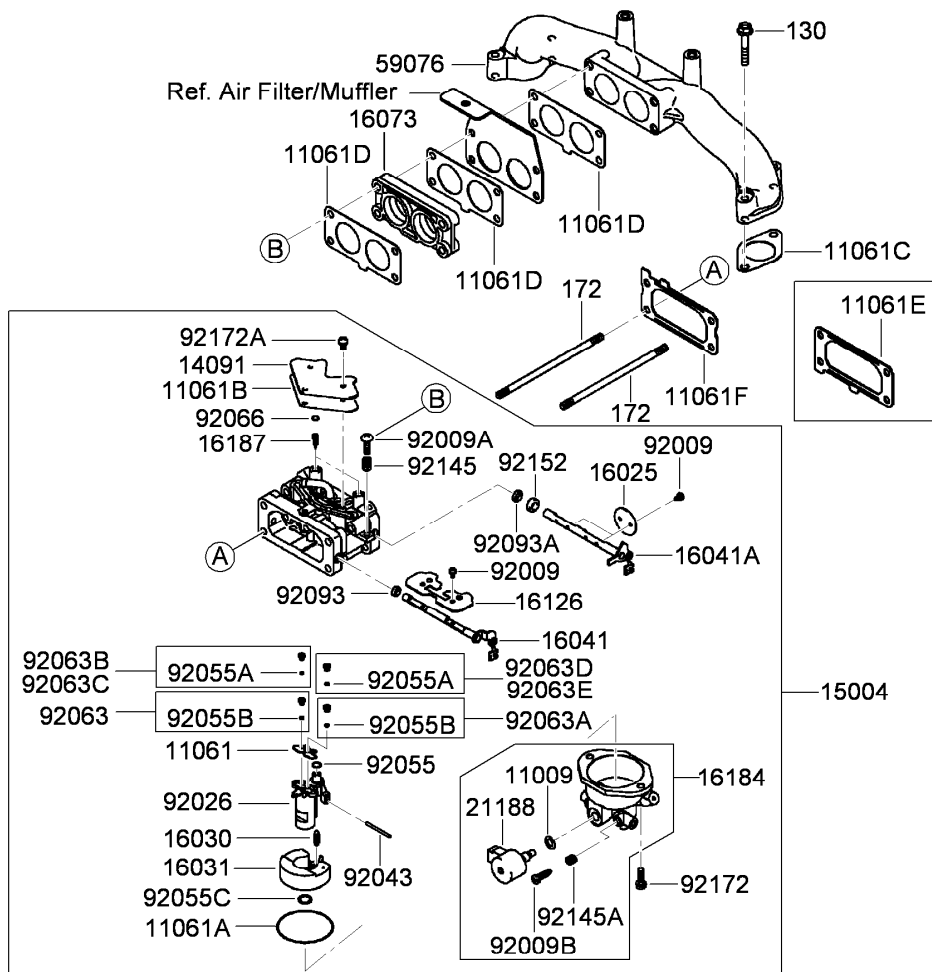

## Carburetor Assembly Kawasaki FX801V-AS04 (continued)

Ref.	Part Number	Qty.	Description
92152	92152-7005	1	Collar ●

Ref.	Part Number	Qty.	Description
92172	92172-7005	2	Screw (M5) ●
92172A	92172-7006	3	Screw (M4) ●

● Obtain parts from [www.kawpowerepc.com](http://www.kawpowerepc.com)

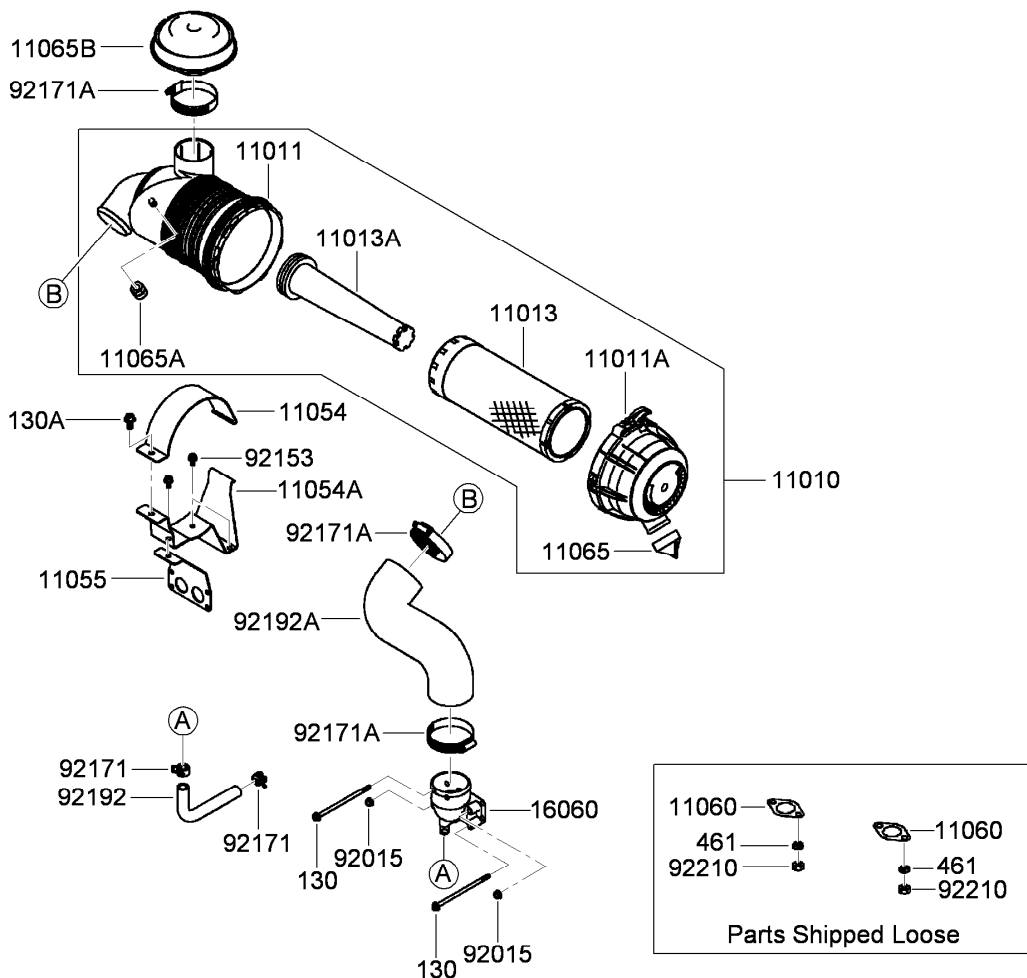

## Air Filter and Muffler Assembly Kawasaki FX801V-AS04

Ref.	Part Number	Qty.	Description
130	130AA06120	2	Bolt-Flanged (6X120) ●
130A	130AA0816	1	Bolt-Flanged (8X16) ●
461	461DA0800	4	Washer-Spring (8Mm) ●
11010	11010-7020	1	Air Filter ASM ●
11011	11011-7047	1	Case-Filter, Air ●
11011A	11011-7050	1	Case-Filter, Air ●
11013	11013-7038	1	Element-Filter, Air ●
11013A	11013-7039	1	Element-Filter, Air ●
11054	11054-7013-9X	1	Bracket ●
11054A	11054-7016-9X	1	Bracket ●
11055	11055-7007-9X	1	Bracket ●
11060	11060-7016	2	Gasket-Muffler ●
11065	11065-7008	1	Cap ●
11065A	11065-7009	1	Cap ●
11065B	11065-7017	1	Cap ●
16060	16060-6007	1	Pipe-Intake ●
92015	92015-1367	2	Nut ●
92153	92153-7043	3	Bolt (6X12) ●
92171	92171-7013	2	Clamp ●
92171A	92171-7023	3	Clamp-Filter, Air ●
92192	92192-7086	1	Tube ●
92192A	92192-7087	1	Tube ●
92210	92210-7027	4	Nut (M8) ●

● Obtain parts from [www.kawpowerepc.com](http://www.kawpowerepc.com)



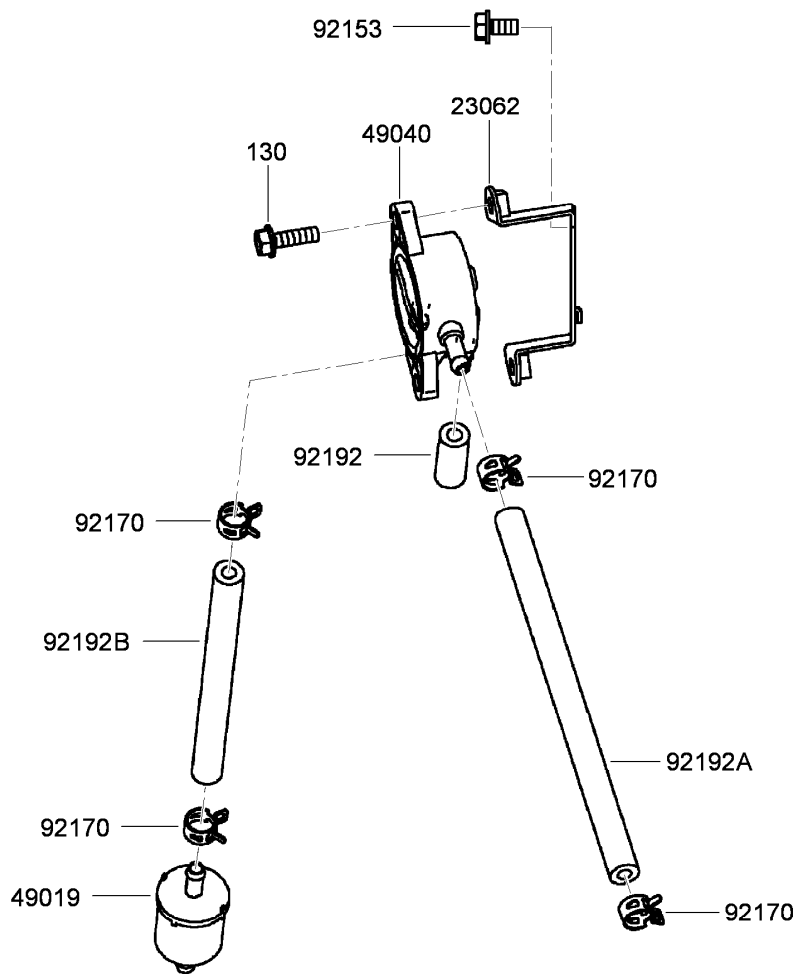

## Fuel Tank and Fuel Valve Assembly Kawasaki FX801V-AS04

Ref.	Part Number	Qty.	Description
130	130AA0620	2	Bolt-Flanged (6X20) ●
23062	23062-7018	1	Bracket ●
49019	49019-7001	1	Filter-Fuel ●
49040	49040-7001	1	Pump-Fuel ●
92153	92153-7043	1	Bolt (6X12) ●
92170	92170-2009	4	Clamp ●
92192	92192-7088	1	Tube (6.4X12.7X28.5) ●
92192A	92192-7137	1	Tube (6.35X12.7X195) ●
92192B	92192-7144	1	Tube (6.35X12.7X140) ●

● Obtain parts from [www.kawpowerepc.com](http://www.kawpowerepc.com)

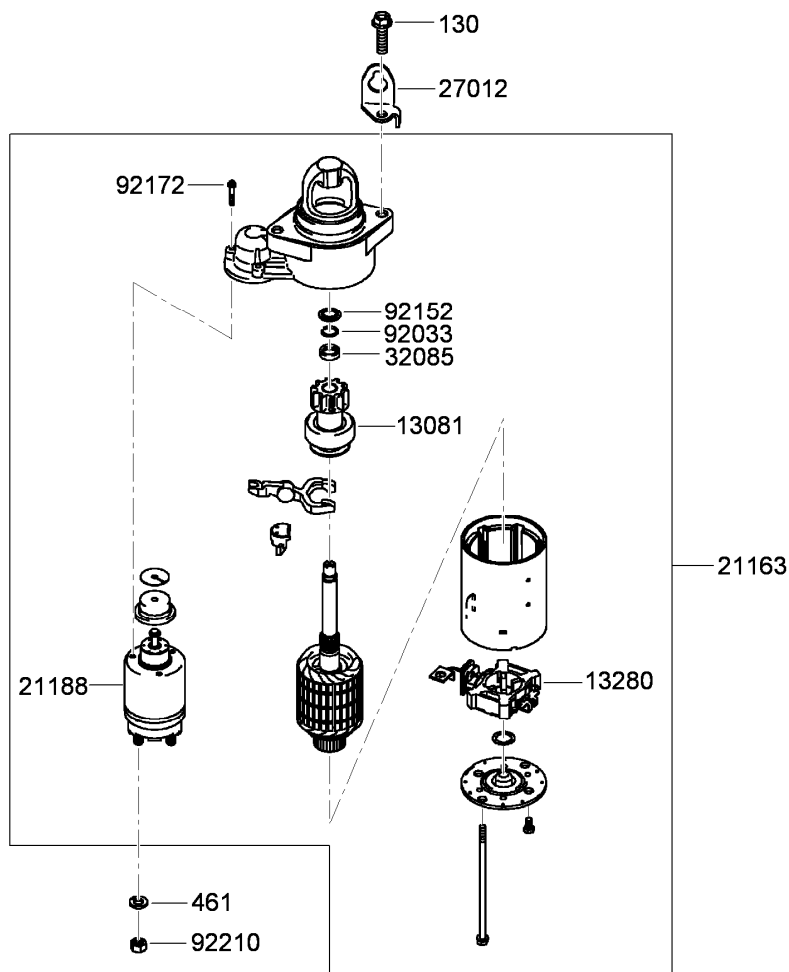

## Starter Assembly Kawasaki FX801V-AS04

<i>Ref.</i>	<i>Part Number</i>	<i>Qty.</i>	<i>Description</i>
130	130AA0830	2	Bolt-Flanged (8X30) ●
461	461DA0800	1	Washer-Spring (8Mm) ●
13081	13081-7001	1	Clutch ASM ●
13280	13280-7002	1	Holder ●
21163	21163-7021	1	Starter-Electric ●
21188	21188-7005	1	Solenoid ●
27012	27012-7005	1	Hook-Lift ●
32085	32085-7001	1	Stopper ●
92033	92033-7014	1	Ring-Snap ●
92152	92152-7013	1	Collar ●
92172	92172-7032	3	Screw ●
92210	92210-7027	1	Nut (M8) ●

● Obtain parts from [www.kawpowerepc.com](http://www.kawpowerepc.com)

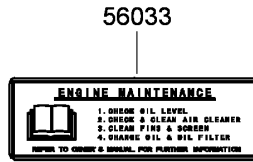

## Label Set Kawasaki FX801V-AS04

<i>Ref.</i>	<i>Part Number</i>	<i>Qty.</i>	<i>Description</i>
56014	56014-7004	1	Emblem ●
56033	56033-7001	1	Label-Manual ●
56070	56070-7001	1	Label-Warning ●

● Obtain parts from [www.kawpowerepc.com](http://www.kawpowerepc.com)

# Attachments and Accessories

## For 74927 Z Master G3 Riding Mower, with 72in TURBO FORCE Side Discharge Mower

<b>Product Name</b>	<b>Model/Part</b>
Blade-Mid Flow, 24.5 inch.....	105-7711-03
Blade-Lo Flow, 24.5 inch.....	105-7712-03
Blade-Atomic, 24.5 inch.....	105-7719-03
Blade-Recycler, 24.5 inch.....	105-7778-03
Blade-Hi Flow, 24.5 inch.....	105-7784-03
6 Pack Blade, 24.5 inch Hi-Flow.....	108-1120
6 Pack Blade, 24.5 inch Atomic.....	108-1126
Hitch Kit.....	109-9487
6 Pack-Blade, 24.5 inch Mid-Flow.....	110-0404
6 Pack-Blade, 24.5 inch Lo-Flow.....	110-0410
6 Pack-Blade, 24.5 inch Recycler.....	110-0411
Hypr-Oil 500 (quart).....	114-4713
Hypr-Oil 500 (gallon).....	114-4714
Hypr-Oil 500-5 (5 gallon).....	114-4715
Bimini Folding Shade Assembly.....	115-4510
Recycler Kit.....	115-7469
Light Kit.....	116-1154
Z Stand Kit.....	117-0354
Operator-Controlled Discharge Chute Kit.....	117-3600
Deluxe Suspension Seat Kit.....	117-6174
Blower and Drive Kit.....	78554
E-Z Vac Triple Bagging System.....	78564
E-Z Vac DFS Collection System.....	78568
Trash Holder Kit.....	TC26

**Notes:**

**Notes:**

**Notes:**



**Count on it.**