



Count on it.

Parts Catalog

**Z Master[®] G3 Riding Mower
with 60in TURBO FORCE[®] Side Discharge
Mower**

Model No. 74945CP—Serial No. 31000001 and Up

Ordering Replacement Parts

To order replacement parts, please supply the part number, the quantity, and the description of each part desired.

Understanding Reference Numbers

Each identified part in an illustration has a reference number. The reference number for a part also appears in the parts list, along with other information about the part.

This catalog uses two special reference number formats, one to indicate parts in a service assembly and another to indicate the quantity of a given part in an illustration.

Service Assembly Reference Numbers

Parts in service assemblies have reference numbers in the form a:b. The a represents the reference number of the entire service assembly and the b represents a sequential number unique to each part within the service assembly.

For example, a wheel assembly might be identified by reference number 6, the tire by 6:1, the valve by 6:2, and the wheel by 6:3. When you order the assembly identified by reference number 6, you receive all parts identified by reference numbers 6:1, 6:2, and 6:3. However, you may also order any part individually. Reference numbers of this type appear in illustration and in parts lists.

Reference Numbers Indicating Quantity

In an illustration, if a reference number indicates more than one part, the reference number has the form nX y. The n represents the quantity of the part, the X is the multiplication symbol, and the y represents the reference number.

For example, in an illustration, the reference number 2X 37 means that two of the parts identified by reference number 37 are indicated.

List of Abbreviations

AR: as required

ASM: assembly

BBC: blade brake control

BHTF: button head thread forming

CARR: carriage

CCW: counter clockwise

CW: clockwise

DEG: degrees

ECM: electronic control module

EXT: external

FH: flat head

GA: gauge

HD: heavy-duty

HF: hex flange

HH: hex head

HHF: hex head flange

HHFTF: hex head flange thread forming

HJ: hex jam

HLH: hex lag head

HOC: height-of-cut

HSBH: hex socket button head

HSFH: hex socket flat head

HSH: hex socket head

HWH: hex washer head

HWHTF: hex washer head thread forming

HYD: hydraulic

LH: left hand

LP: Liquid Propane

NI: nylon insert

NPTF: national pipe thread fine

PFH: phillips flat head

PPH: phillips pan head

PPHTF: phillips pan head thread forming

PRH: phillips round head

PTH: phillips truss head

PTO: power-take-off

RH: right hand

ROPS: roll-over protection system

RRB: rear roller brush

SFH: slotted fillister head

SHH: slotted hex head

SHWH: slotted hex washer head

SPH: slotted pan head

SQH: square head

SRH: slotted round head

STD: standard

TAP: self tapping

TTH: torx truss head

Contents

| | |
|---------------------------------------------------------|----|
| Hydraulic Pump, Idler and Belt Assembly | 4 |
| Pump Idler Assembly No. 116-1255 | 5 |
| LH Hydro Assembly No. 116-1324 | 6 |
| RH Hydro Assembly No. 116-1325 | 7 |
| Rear Wheel and Park Brake Assembly | 8 |
| Brake Handle Assembly No. 116-1878 | 9 |
| Fuel System Assembly | 10 |
| Fuel Tank Assembly No. 109-9357 | 11 |
| Seat Mounting Assembly | 12 |
| Seat Assembly No. 116-0035 | 13 |
| Motion Control Assembly | 14 |
| Fender, Console and Control Assembly | 15 |
| LH Console Assembly No. 115-7401 | 16 |
| RH Console Assembly No. 115-7400 | 17 |
| Electrical Assembly | 18 |
| Deck Lift Assembly | 19 |
| Height-of-Cut Assembly No. 109-7438 | 20 |
| Engine, Clutch and Muffler Assembly | 21 |
| Deck Assembly | 22 |
| Deck Decal Assembly No. 114-5815 | 23 |
| Idler Assembly | 24 |
| Spindle Assembly No. 117-3840 | 25 |
| Rubber Deflector Assembly No. 108-7770 | 26 |
| Front Frame and Caster Wheel Assembly | 27 |
| Roll-Over Protection System Assembly No. 116-0232 | 28 |
| Caster Wheel and Fork Assembly | 29 |
| Attachments and Accessories | 30 |

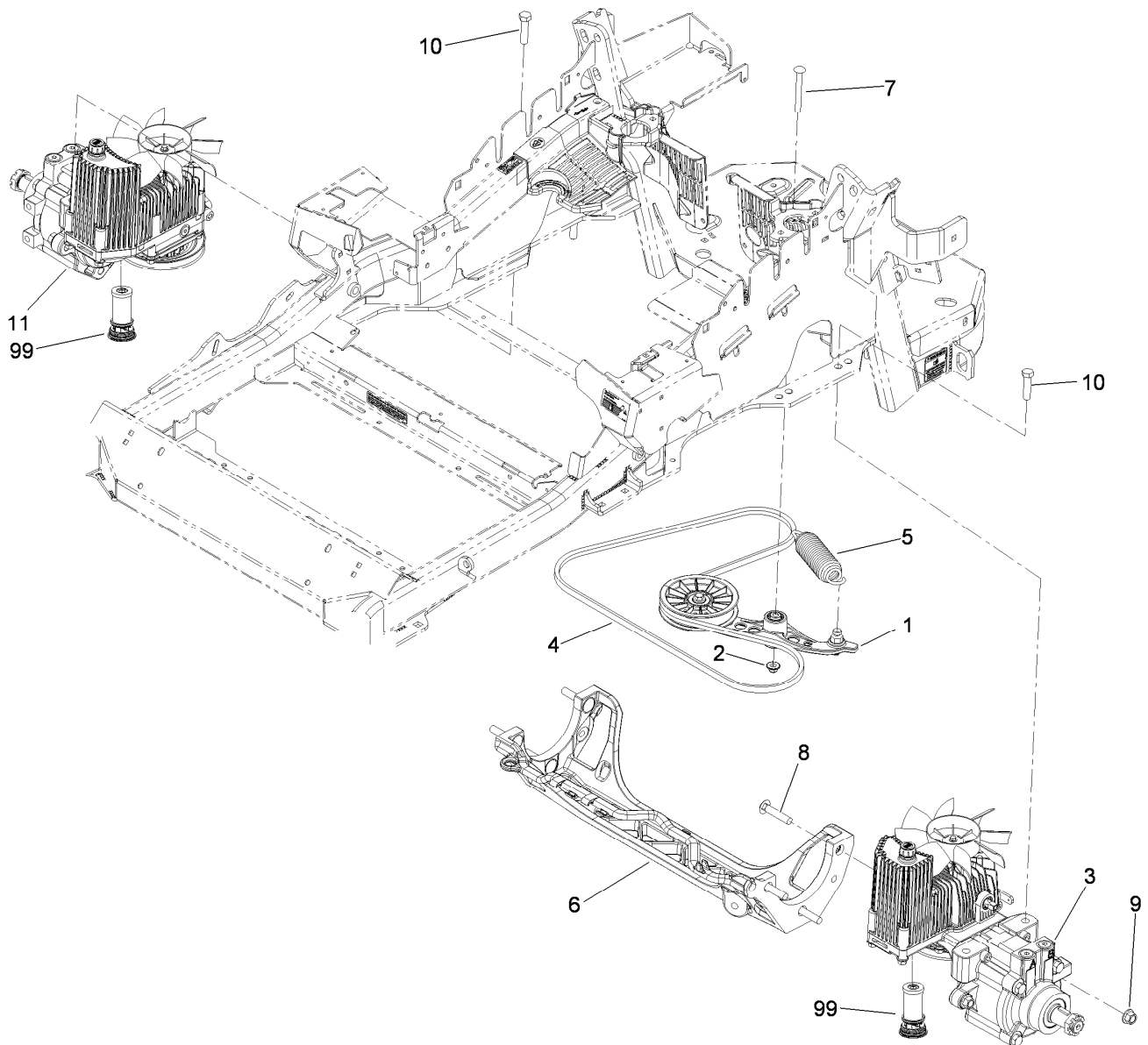

Hydraulic Pump, Idler and Belt Assembly

| Ref. | Part Number | Qty. | Description |
|------|-------------|------|-----------------------------|
| 1 | 116-1255 | 1 | Pump Idler ASM |
| 2 | 109-6658 | 1 | Nut-Flange, NI |
| 3 | 116-1324 | 1 | LH Hydro ASM (12Cc W/Shock) |
| 4 | 109-3388 | 1 | Belt |
| 5 | 116-0133 | 1 | Extension-Spring |
| 6 | 109-9375 | 1 | Cradle-Hydro |
| 7 | 116-1502 | 1 | Bolt-Shoulder, Carriage |
| 8 | 3233-34 | 6 | Screw-CARR |
| 9 | 99-5107 | 6 | Nut-Lock |
| 10 | 325-8 | 4 | Screw-HH |
| 11 | 116-1325 | 1 | RH Hydro ASM (12Cc W/Shock) |
| 99 | 114-4713 | 1 | Hypr-Oil 500 (Quart) ● |
| 99 | 114-4714 | 1 | Hypr-Oil 500 (Gallon) ● |
| 99 | 114-4715 | 1 | Hypr-Oil 500-5 (5 Gallon) ● |
| 99 | 117-0390 | 1 | Filter-Hydro |

● Not illustrated

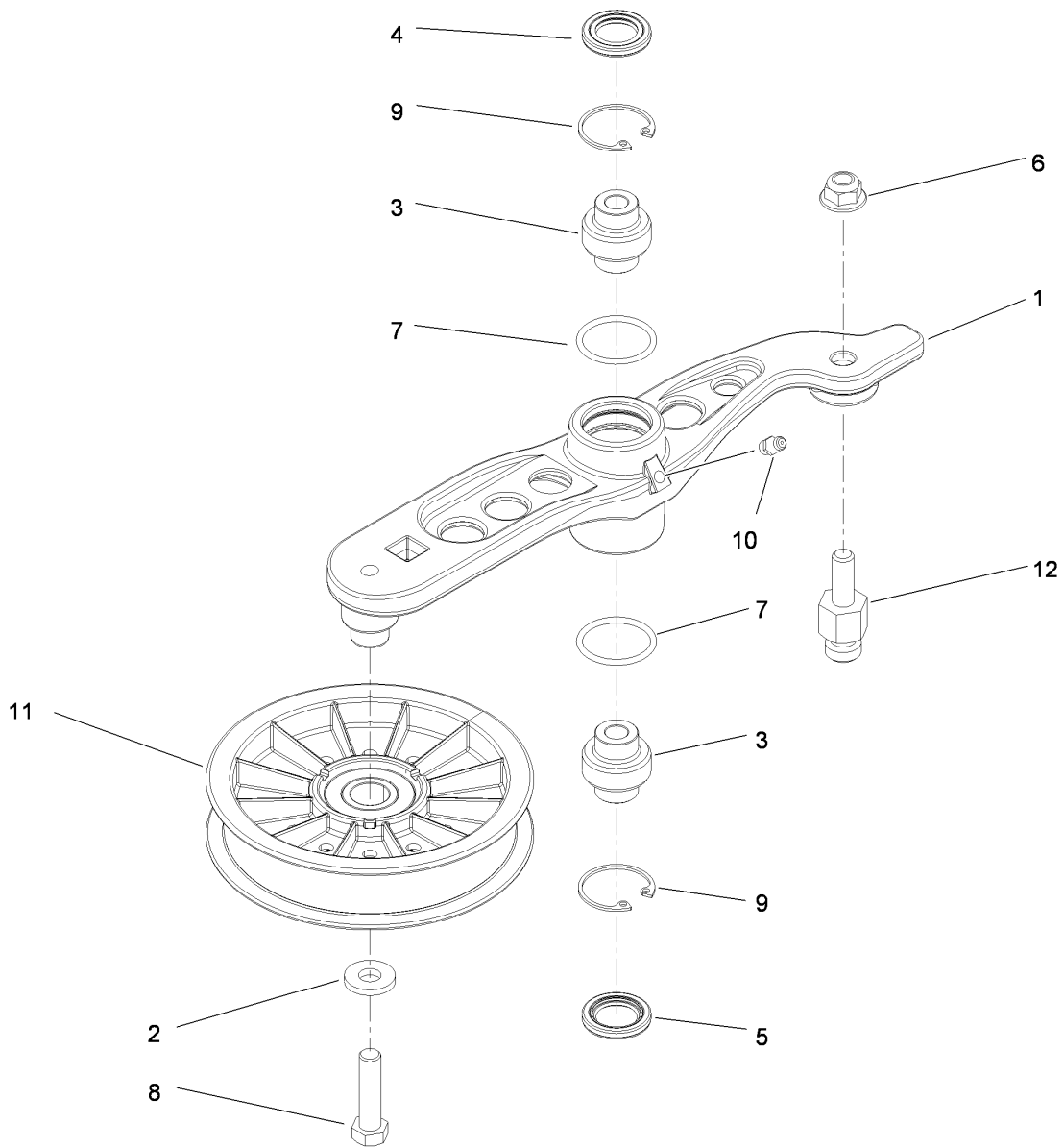

Pump Idler Assembly No. 116-1255

| Ref. | Part Number | Qty. | Description |
|------|-------------|------|--------------------|
| 1 | | 1 | Arm-Pump, Idler ● |
| 2 | 43-0940 | 1 | Spacer-Hub, Blower |
| 3 | 103-3504 | 2 | Bearing-Spherical |
| 4 | 103-3505 | 1 | Seal-Double Lip |
| 5 | 103-3506 | 1 | Seal-Single Lip |
| 6 | 109-6658 | 1 | Nut-Flange, NI |
| 7 | 106-7159 | 2 | O-Ring |
| 8 | 323-8 | 1 | Screw-HH |
| 9 | 32120-10 | 2 | Ring-Snap |
| 10 | 302-19 | 1 | Fitting-Grease |
| 11 | 109-8076 | 1 | Pulley-Idler |
| 12 | 109-7399 | 1 | Pin-Anchor, Spring |

● Not serviced separately

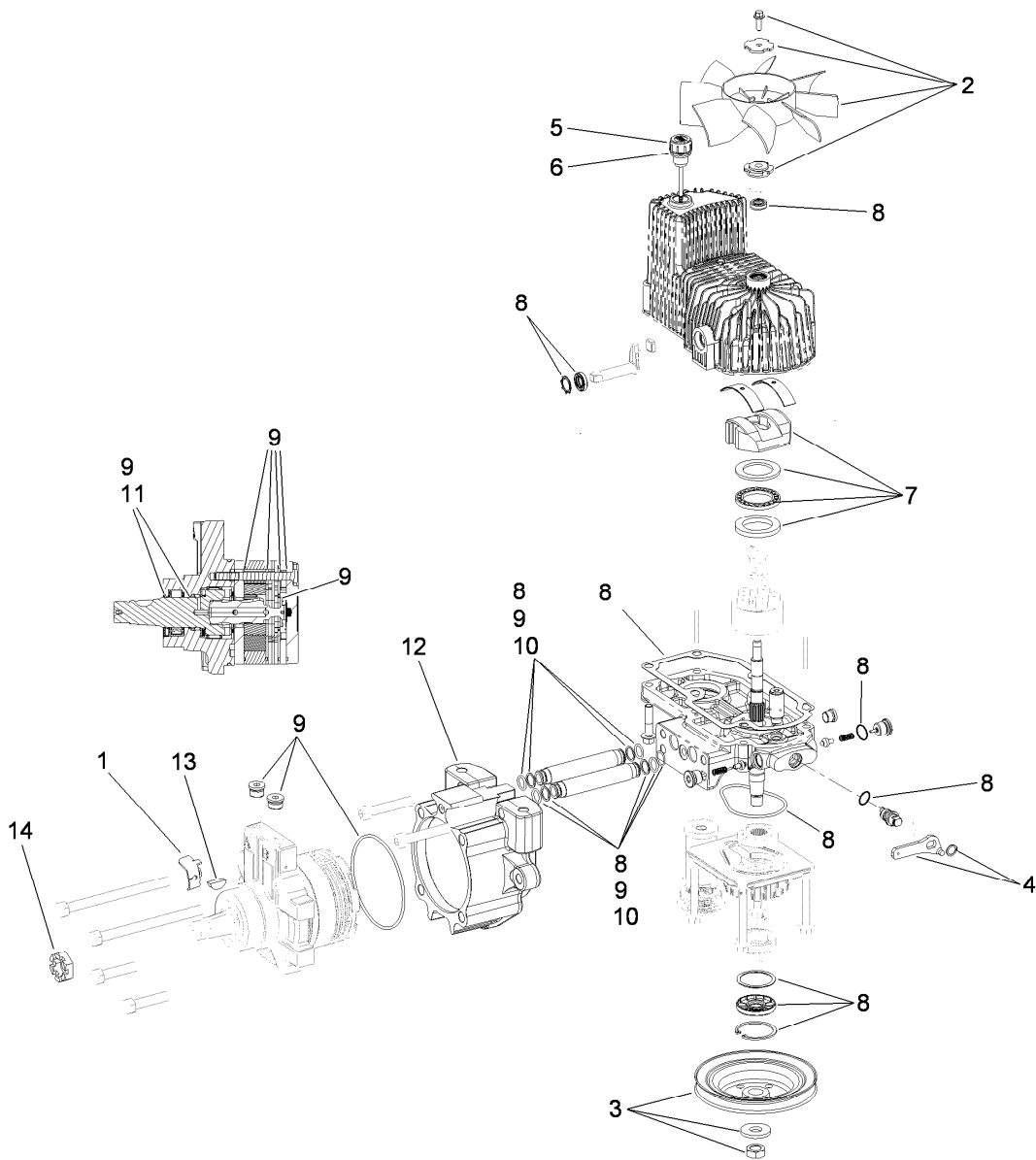

LH Hydro Assembly No. 116-1324

| Ref. | Part Number | Qty. | Description |
|------|-------------|------|----------------------------|
| 1 | 116-1758 | 1 | Bracket-Anchor, Cable |
| 2 | 116-0233 | 1 | Fan Kit |
| 3 | 116-0234 | 1 | Pulley Kit |
| 4 | 116-0235 | 1 | Handle-Bypass Valve, Hydro |
| 5 | 116-0236 | 1 | Dipstick-Hydro W/Gasket |
| 6 | 116-0237 | 1 | Gasket-Dipstick, Hydro |
| 7 | 116-1367 | 1 | Swash Block Kit |
| 8 | 116-1368 | 1 | Pump Seal Kit |
| 9 | 116-1369 | 1 | Motor Seal Kit |
| 10 | 116-1370 | 1 | Tube Seal Kit |
| 11 | 116-1371 | 1 | Output Shaft Seal Kit |
| 12 | 116-1372 | 1 | Cup-Nose |
| 13 | 3257-42 | 1 | Key-Woodruff |
| 14 | 1-809036 | 1 | Nut-HH |
| 99 | 116-1373 | 1 | Flow Test Kit ● |

● Not illustrated

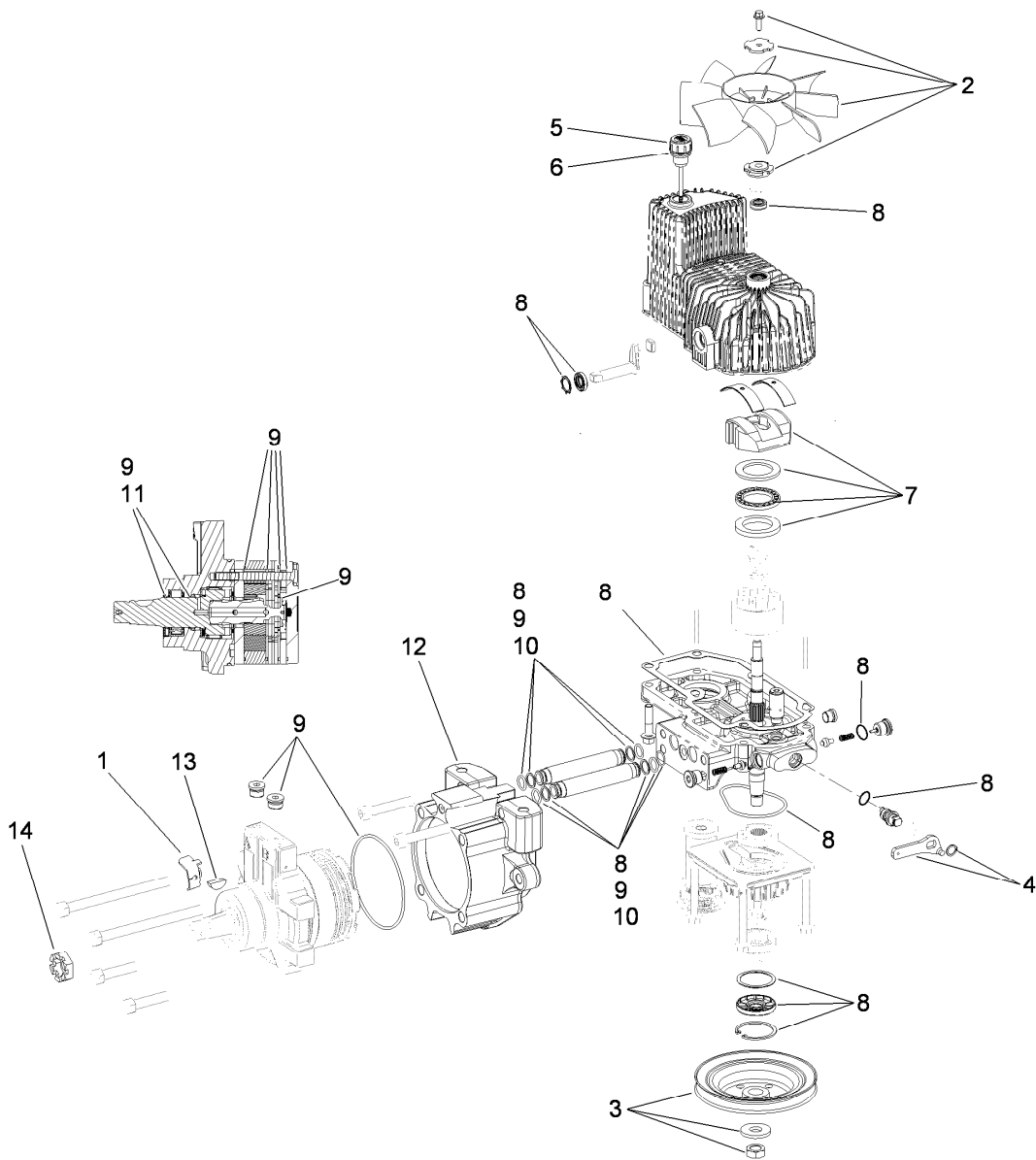

RH Hydro Assembly No. 116-1325

| Ref. | Part Number | Qty. | Description |
|------|-------------|------|----------------------------|
| 1 | 116-1758 | 1 | Bracket-Anchor, Cable |
| 2 | 116-0233 | 1 | Fan Kit |
| 3 | 116-0234 | 1 | Pulley Kit |
| 4 | 116-0235 | 1 | Handle-Bypass Valve, Hydro |
| 5 | 116-0236 | 1 | Dipstick-Hydro W/Gasket |
| 6 | 116-0237 | 1 | Gasket-Dipstick, Hydro |
| 7 | 116-1367 | 1 | Swash Block Kit |
| 8 | 116-1368 | 1 | Pump Seal Kit |
| 9 | 116-1369 | 1 | Motor Seal Kit |
| 10 | 116-1370 | 1 | Tube Seal Kit |
| 11 | 116-1371 | 1 | Output Shaft Seal Kit |
| 12 | 116-1372 | 1 | Cup-Nose |
| 13 | 3257-42 | 1 | Key-Woodruff |
| 14 | 1-809036 | 1 | Nut-HH |
| 99 | 116-1373 | 1 | Flow Test Kit ● |

● Not illustrated

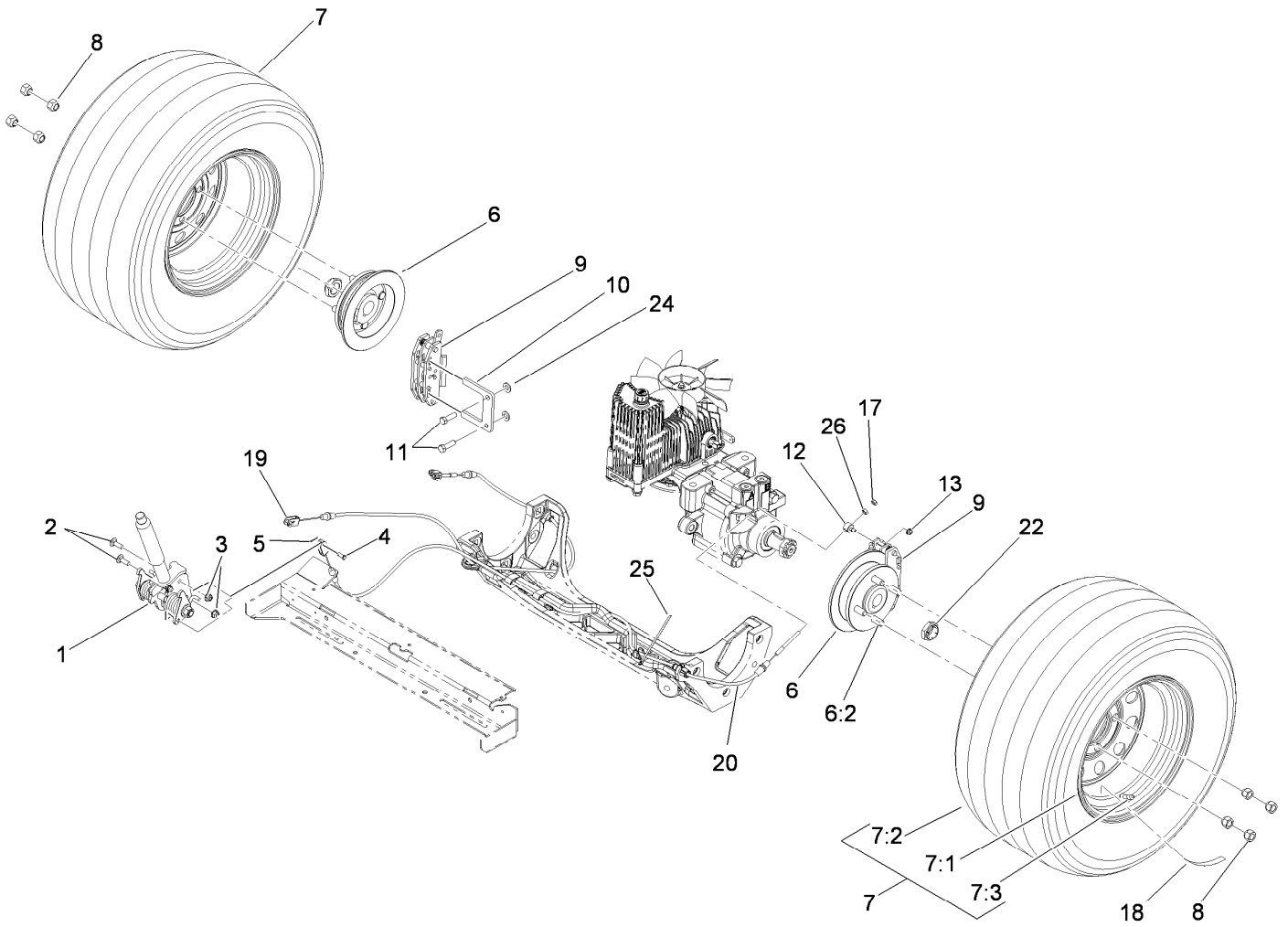

Rear Wheel and Park Brake Assembly

| <i>Ref.</i> | <i>Part Number</i> | <i>Qty.</i> | <i>Description</i> | <i>Ref.</i> | <i>Part Number</i> | <i>Qty.</i> | <i>Description</i> |
|-------------|--------------------|-------------|--------------------|-------------|--------------------|-------------|------------------------|
| 1 | 116-1878 | 1 | Brake Handle ASM | 10 | 109-0958 | 2 | Plate-Mount, Brake |
| 2 | 3230-2 | 2 | Bolt-CARR | 11 | 92-5727 | 4 | Screw-Lock, Patch |
| 3 | 104-8300 | 2 | Nut-Flange, NI | 12 | 112-8379 | 2 | Swivel |
| 4 | 60-1730 | 2 | Pin-Clevis | 13 | 104-7201 | 2 | Nut-HF |
| 5 | 3272-1 | 2 | Pin-Cotter | 17 | 3296-13 | 2 | Nut-Lock NI |
| 6 | 116-1746 | 2 | Wheel Hub ASM | 18 | 116-2643 | 2 | Decal-Wheel Nut Torque |
| 6:2 | 116-1696 | 4 | Stud-Wheel | 19 | 115-3584 | 1 | Cable |
| 7 | 115-3588 | 2 | Wheel And Tire ASM | 20 | 115-3585 | 1 | Cable |
| 7:1 | 109-2871 | 1 | Rim ASM | 22 | 116-1399 | 2 | Locknut, Wheel Motor |
| 7:2 | 1-633993 | 1 | Tire | 24 | 3256-24 | 4 | Washer-Flat |
| 7:3 | 232-27 | 1 | Stem-Valve | 25 | 116-0940 | 1 | Tie-Cable |
| 8 | 242-50 | 8 | Nut-Lug | 26 | 3219-1 | 2 | Nut-Hex |
| 9 | 109-2889 | 2 | Caliper-Brake | | | | |

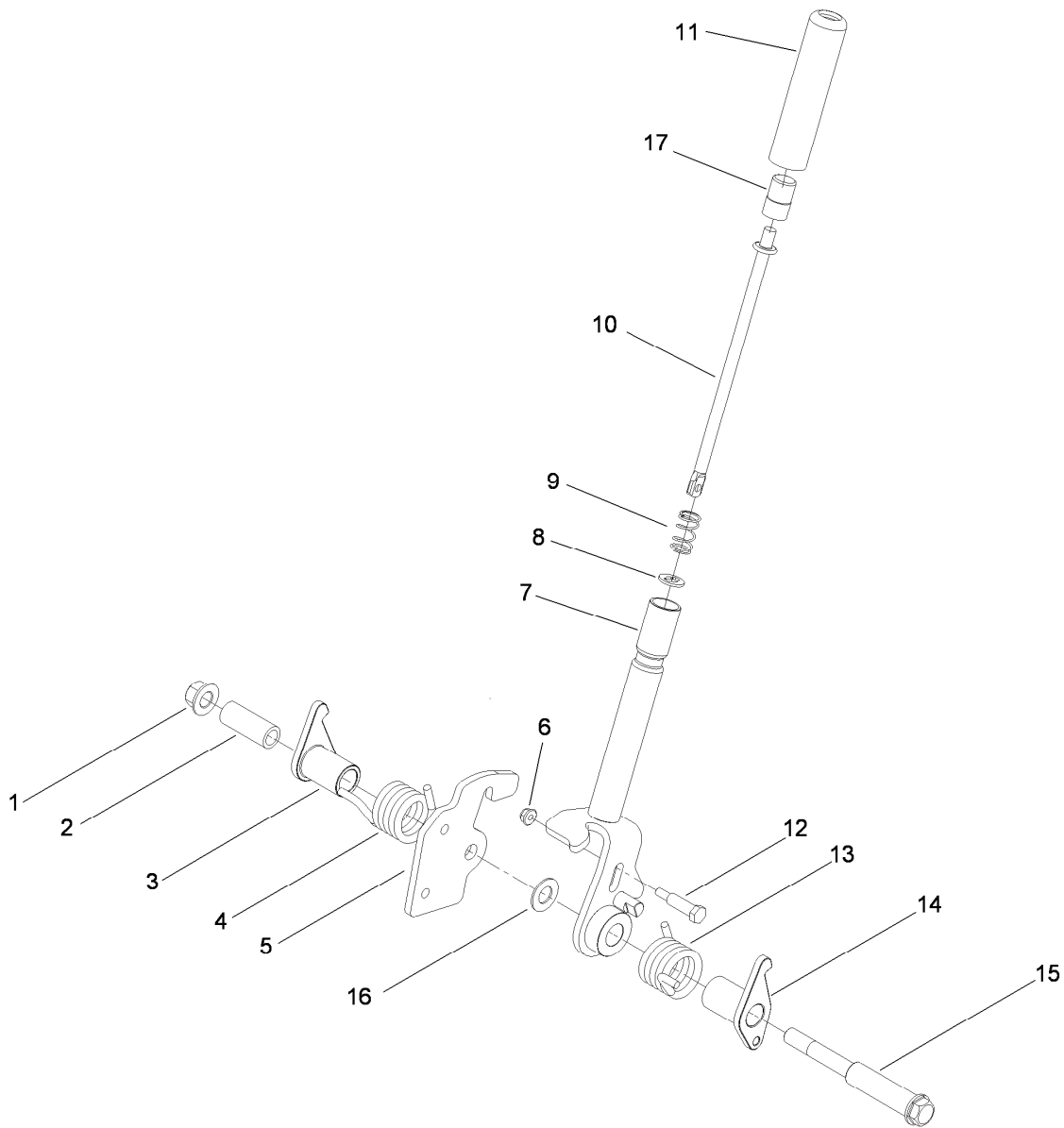

Brake Handle Assembly No. 116-1878

| <i>Ref.</i> | <i>Part Number</i> | <i>Qty.</i> | <i>Description</i> | <i>Ref.</i> | <i>Part Number</i> | <i>Qty.</i> | <i>Description</i> |
|-------------|--------------------|-------------|--------------------|-------------|--------------------|-------------|--------------------|
| 1 | 99-5107 | 1 | Nut-Lock | 10 | 115-3581 | 1 | Rod-Release, Brake |
| 2 | 117-0380 | 1 | Spacer | 11 | 115-3592 | 1 | Grip |
| 3 | 115-3580 | 1 | Arm-Brake, LH | 12 | 112-8387 | 1 | Bolt-Shoulder |
| 4 | 117-0376 | 1 | Spring-Torsion, RH | 13 | 117-0375 | 1 | Spring-Torsion, LH |
| 5 | 115-3574 | 1 | Plate-Latch | 14 | 115-3579 | 1 | Arm-Brake, RH |
| 6 | 104-7201 | 1 | Nut-HF | 15 | 117-0379 | 1 | Bolt-Shoulder |
| 7 | 116-1876-03 | 1 | Brake Handle ASM | 16 | 3256-26 | 1 | Washer-Flat |
| 8 | 114-1207 | 1 | Washer-Special | 17 | 115-2750 | 1 | Knob |
| 9 | 114-8187 | 1 | Spring-Compression | | | | |

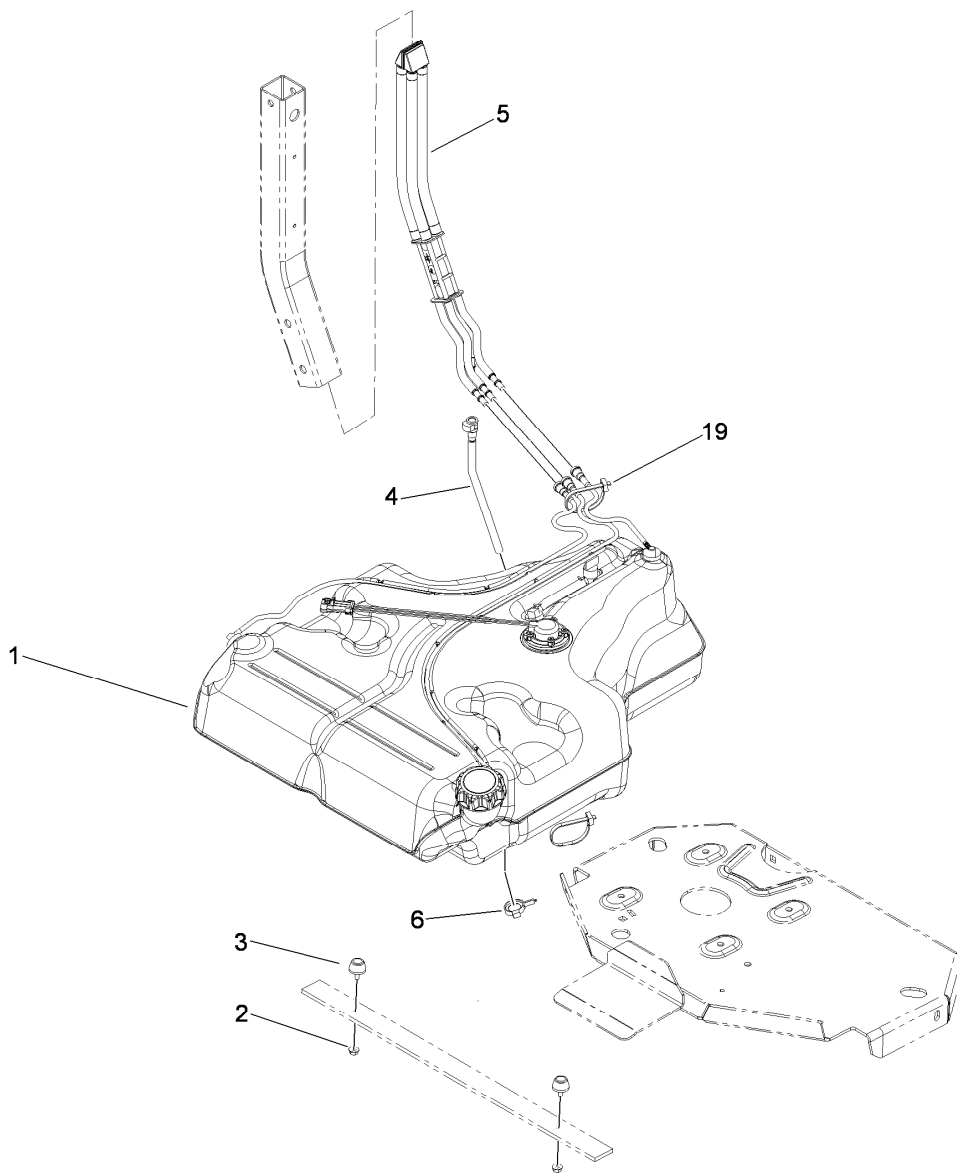

Fuel System Assembly

| Ref. | Part Number | Qty. | Description |
|-------------|--------------------|-------------|------------------------|
| 1 | 109-9357 | 1 | Fuel Tank ASM |
| 2 | 32128-33 | 2 | Nut-HF |
| 3 | 109-2365 | 2 | Bumper-Rubber (W/Stud) |
| 4 | 109-9450 | 1 | Tube-Vent, Fuel Drain |
| 5 | 109-9491 | 1 | Fuel Manifold Vent ASM |
| 6 | 105-1853 | 1 | Clamp-Hose |
| 19 | 1-303335 | 1 | Tie-Plastic |

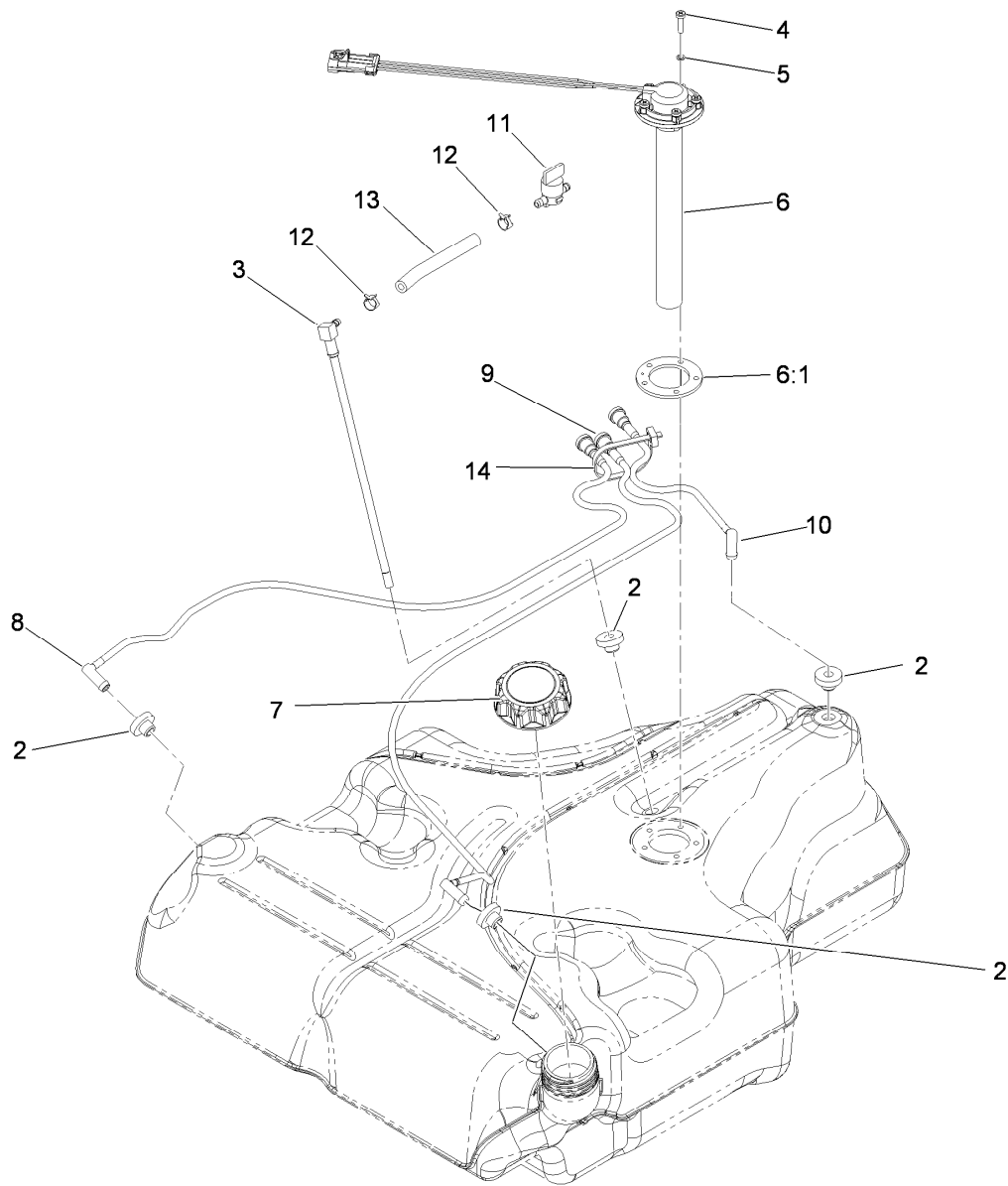

Fuel Tank Assembly No. 109-9357

| <i>Ref.</i> | <i>Part Number</i> | <i>Qty.</i> | <i>Description</i> |
|-------------|--------------------|-------------|-----------------------------------|
| 2 | 46-6560 | 4 | Bushing |
| 3 | 116-2459 | 1 | Fuel Line Kit (With Grommet) |
| 4 | 9107944 | 5 | Screw-Pan |
| 5 | 3253-17 | 5 | Washer-Lock |
| 6 | 116-0003 | 1 | Sender-Fuel Level |
| 6:1 | 109-9620 | 1 | Gasket-Sender, Fuel |
| 7 | 109-9619 | 1 | Cap-Fuel |
| 8 | 116-2460 | 1 | RH Vent Line Kit (With Grommet) |
| 9 | 116-2461 | 1 | LH Vent Line Kit (With Grommet) |
| 10 | 116-2462 | 1 | Rear Vent Line Kit (With Grommet) |
| 11 | 1-603770 | 1 | Valve-Fuel |
| 12 | 2412-98 | 2 | Clamp |
| 13 | 109-0650 | 1 | Hose-Fuel |
| 14 | 1-303335 | 1 | Tie-Plastic |

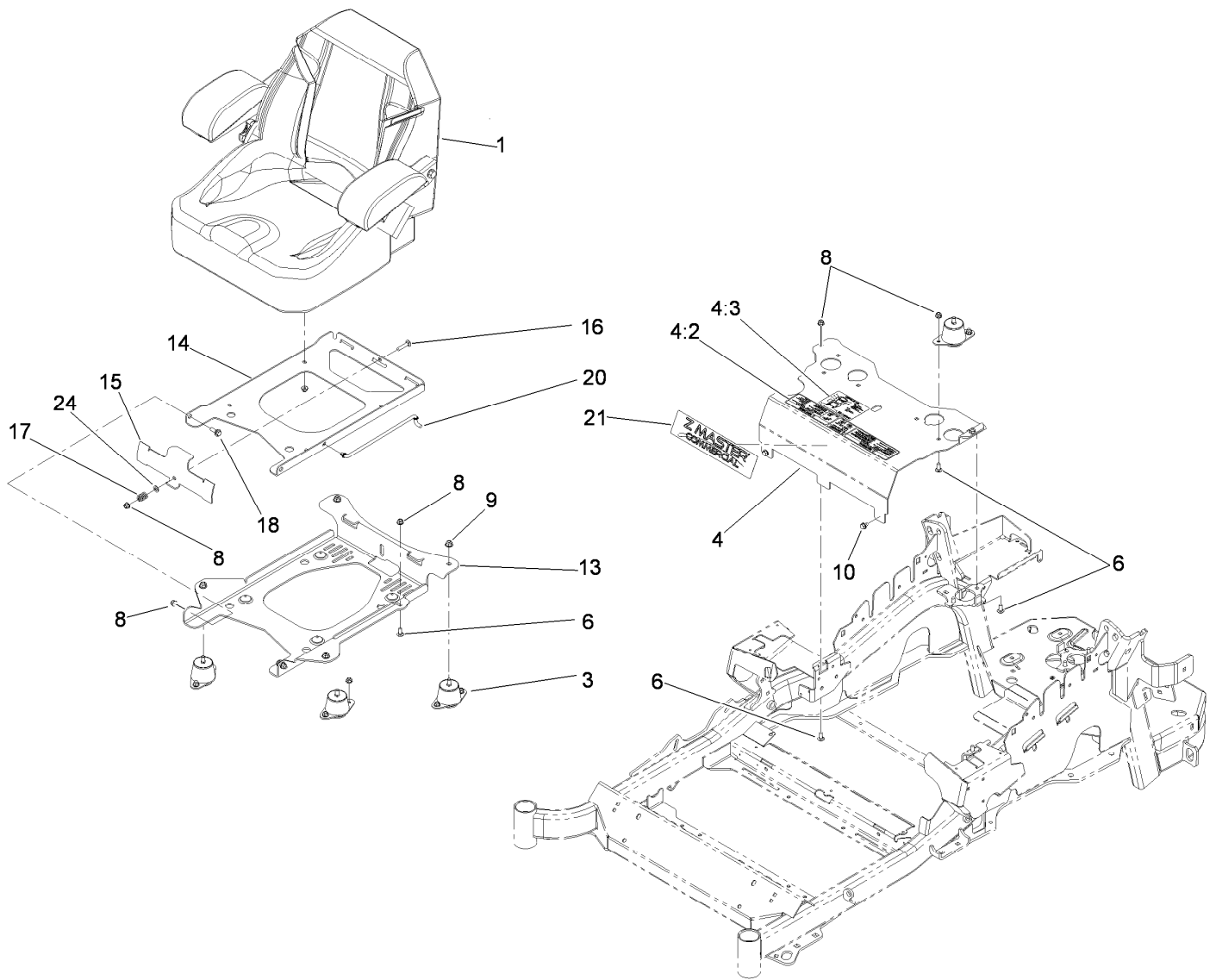

Seat Mounting Assembly

| Ref. | Part Number | Qty. | Description | Ref. | Part Number | Qty. | Description |
|------|-------------|------|-------------------|------|-------------|------|--------------------------|
| 1 | 116-0035 | 1 | Seat-Standard | 13 | 116-0181-03 | 1 | Plate-Support, Seat Tilt |
| 3 | 109-9034 | 4 | Isolator-Seat | 14 | 116-0179-03 | 1 | Plate-Frame, Seat Tilt |
| 4 | 116-2323 | 1 | Mount-Seat | 15 | 109-9881-03 | 1 | Plate-Latch, Seat |
| 4:2 | 109-7069 | 1 | Decal-Console | 16 | 3230-4 | 1 | Screw-CARR |
| 4:3 | 116-0211 | 1 | Decal-Service Aid | 17 | 107-3017 | 1 | Spring-Compression |
| 6 | 3230-23 | 11 | Screw-CARR | 18 | 116-1297 | 2 | Screw-Shoulder |
| 8 | 104-8300 | 18 | Nut-Flange, NI | 20 | 116-0070 | 1 | Rod-Prop |
| 9 | 104-8301 | 4 | Nut-Flange, NI | 21 | 114-5878 | 1 | Decal-Dash |
| 10 | 9266934 | 2 | Screw | 24 | 3256-23 | 1 | Washer-Flat |

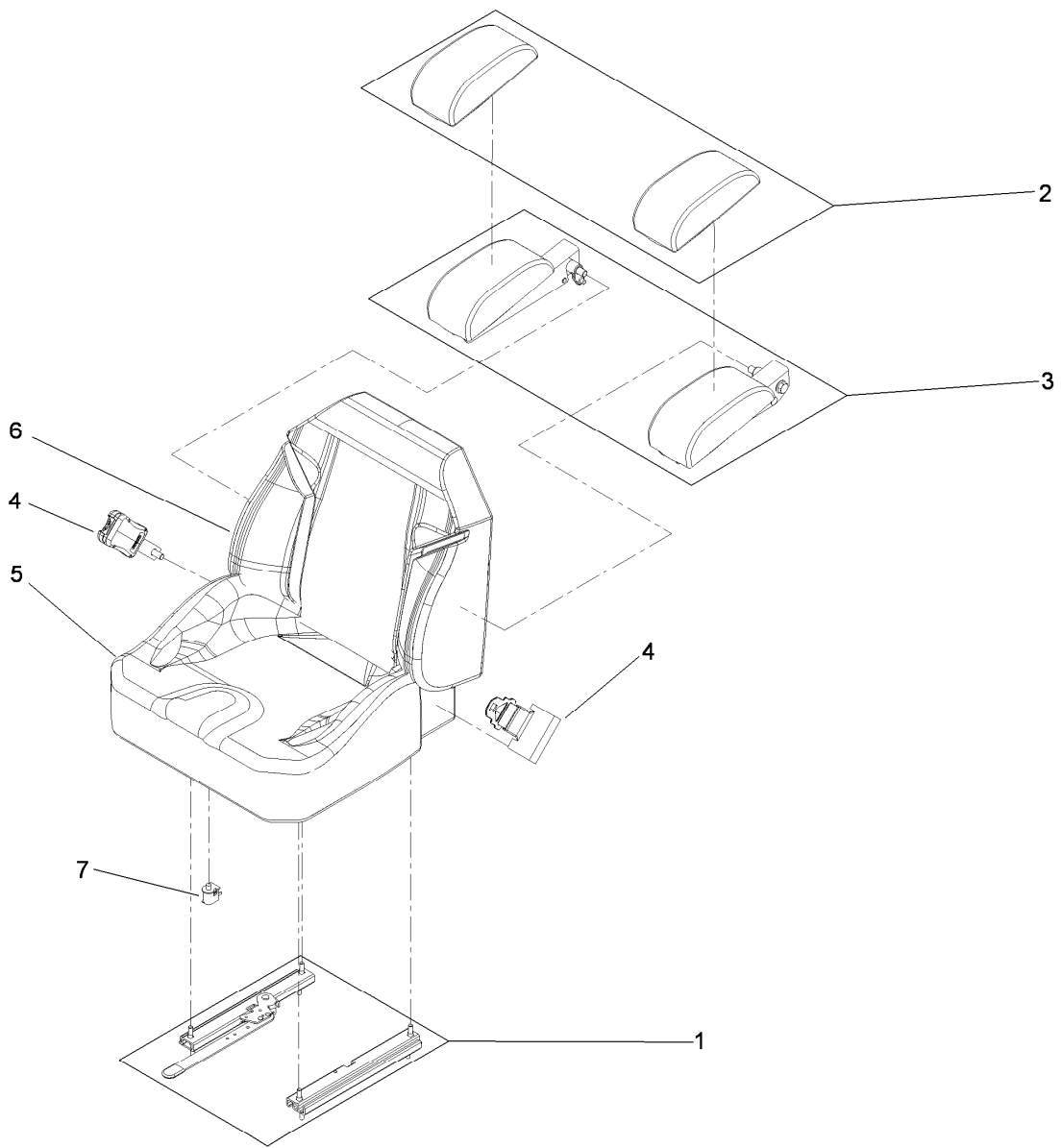

Seat Assembly No. 116-0035

| <i>Ref.</i> | <i>Part Number</i> | <i>Qty.</i> | <i>Description</i> |
|-------------|--------------------|-------------|--------------------|
| 1 | 109-9801 | 1 | Seat Track Set |
| 2 | 109-9802 | 1 | Arm Rest Pad Set |
| 3 | 109-9803 | 1 | Arm Rest Set |
| 4 | 109-9805 | 1 | Seat Belt Kit |
| 5 | 109-9806 | 1 | Cover-Cushion |
| 6 | 109-9808 | 1 | Cover-Back |
| 7 | 82-2190 | 1 | Switch-Bail |

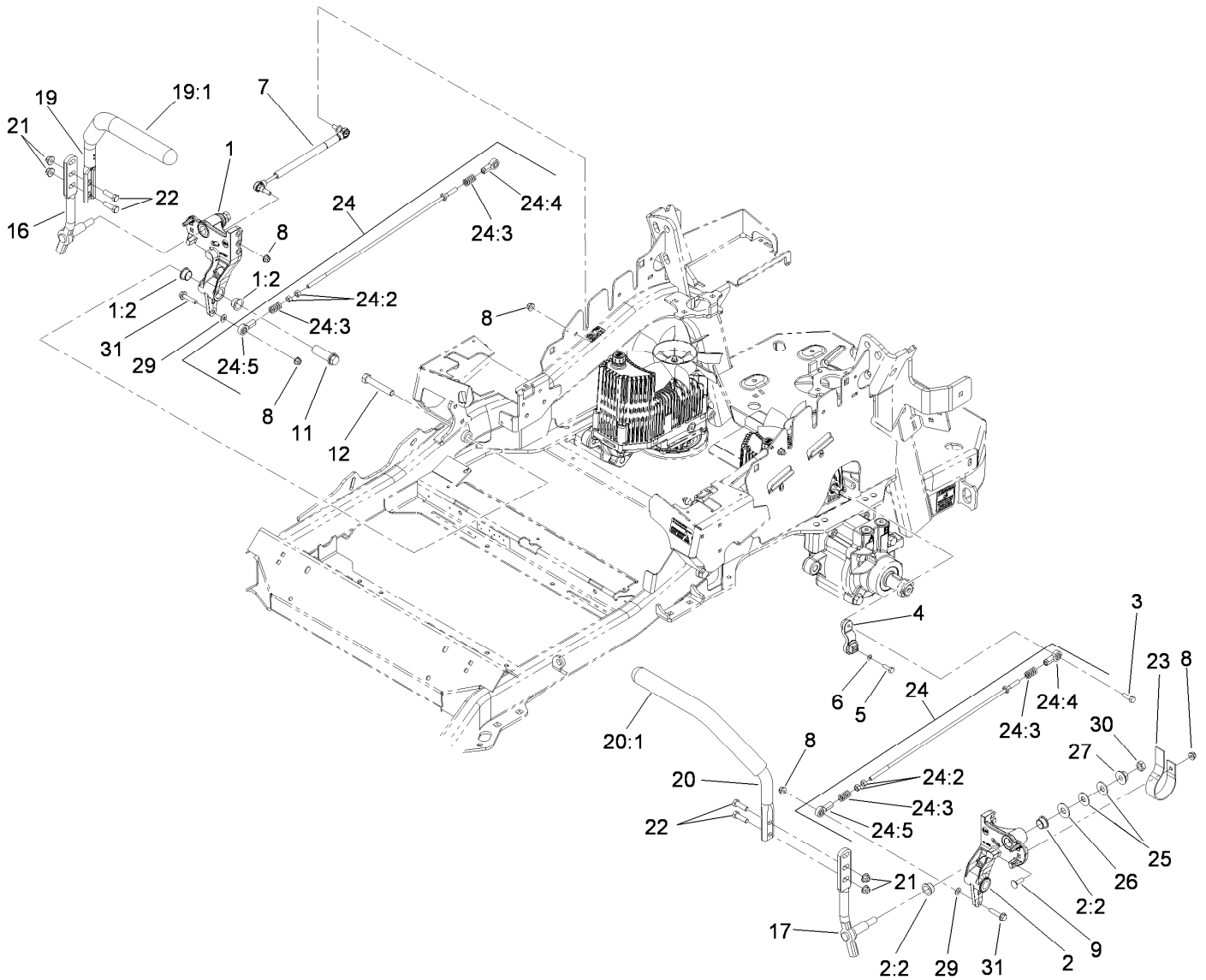

Motion Control Assembly

| Ref. | Part Number | Qty. | Description | Ref. | Part Number | Qty. | Description |
|------|-------------|------|-----------------------------------|------|-------------|------|------------------------|
| 1 | 116-0880 | 1 | RH Motion Control And Bushing ASM | 19:1 | 106-9987 | 1 | Grip-Control, Motion |
| 1:2 | 109-8054 | 4 | Bushing-Flange | 20 | 109-6592 | 1 | LH Steering Handle ASM |
| 2 | 116-0881 | 1 | LH Motion Control And Bushing ASM | 20:1 | 106-9987 | 1 | Grip-Control, Motion |
| 2:2 | 109-8054 | 4 | Bushing-Flange | 21 | 104-8301 | 4 | Nut-Flange, NI |
| 3 | 116-0648 | 2 | Screw-Thread Locking | 22 | 323-7 | 4 | Screw-HH |
| 4 | 109-4581 | 2 | Arm-Control, Pump | 23 | 109-5575 | 2 | Spring-Leaf |
| 5 | 9080046 | 2 | Screw-HH | 24 | 109-8106 | 2 | Front Pump Linkage ASM |
| 6 | 1-303435 | 2 | Washer-Spring | 24:2 | 3219-2 | 2 | Nut-Hex |
| 7 | 116-0027 | 2 | Damper-Control, Motion | 24:3 | 1-323245 | 2 | Spring-Compression |
| 8 | 104-8300 | 8 | Nut-Flange, NI | 24:4 | 1-633152 | 1 | Balljoint-LH |
| 9 | 3230-2 | 2 | Bolt-CARR | 24:5 | 1-543017 | 1 | Balljoint-RH |
| 11 | 109-5891 | 2 | Hub-Threaded | 25 | 109-9505 | 4 | Washer-Spring |
| 12 | 325-12 | 2 | Screw-HH | 26 | 3256-6 | 2 | Washer-Flat |
| 16 | 116-0039 | 1 | Lever-Control Motion, RH | 27 | 32128-56 | 2 | Nut-HF |
| 17 | 116-0040 | 1 | Lever-Control Motion, LH | 29 | 3256-23 | 2 | Washer-Flat |
| 19 | 109-6591 | 1 | RH Steering Handle ASM | 30 | 3218-5 | 2 | Nut-Jam |
| | | | | 31 | 115-1794 | 2 | Screw-HHF |

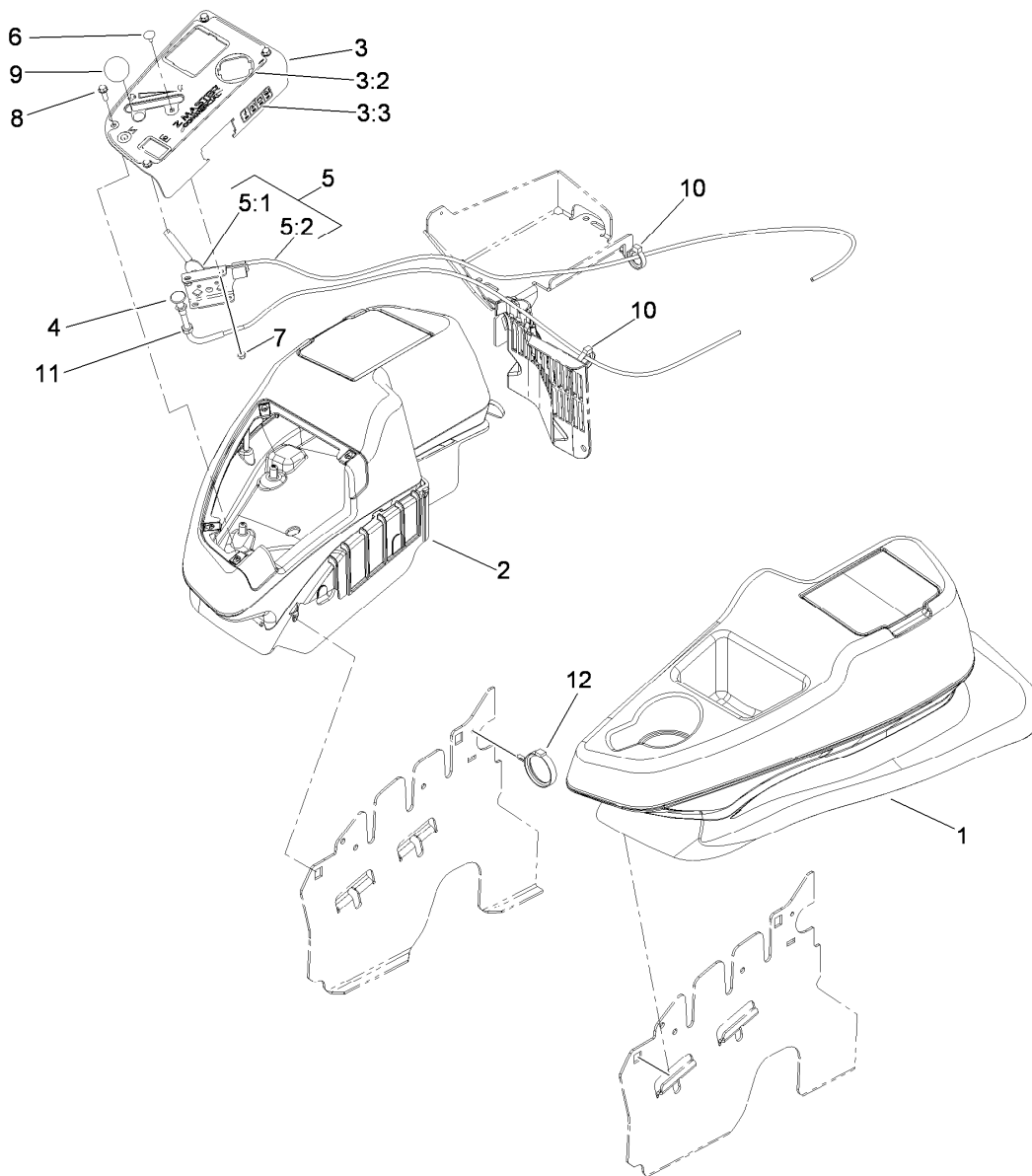

Fender, Console and Control Assembly

| Ref. | Part Number | Qty. | Description |
|------|-------------|------|----------------------------|
| 1 | 115-7401 | 1 | LH Wide Fender/Console ASM |
| 2 | 115-7400 | 1 | RH Wide Fender/Console ASM |
| 3 | 114-9836 | 1 | Control Panel ASM |
| 3:2 | 114-9834 | 1 | Decal-Panel, Control |
| 3:3 | 114-4466 | 1 | Decal-Fuses |
| 4 | 115-2753 | 1 | Choke Control ASM |
| 5 | 110-5727 | 1 | Control-Throttle ASM |

| Ref. | Part Number | Qty. | Description |
|------|-------------|------|----------------|
| 5:1 | 112-2334 | 1 | Lever-Throttle |
| 5:2 | 110-5728 | 1 | Cable Throttle |
| 6 | 1-807513 | 2 | Bolt-CARR |
| 7 | 3296-2 | 2 | Nut-Lock, NI |
| 8 | 32105-15 | 4 | Screw |
| 9 | 1-603175 | 1 | Knob-Ball |
| 10 | 105-1853 | 1 | Clamp-Hose |
| 11 | 3220-3 | 1 | Nut-HJ |
| 12 | 117-7817 | 1 | Clamp-Harness |

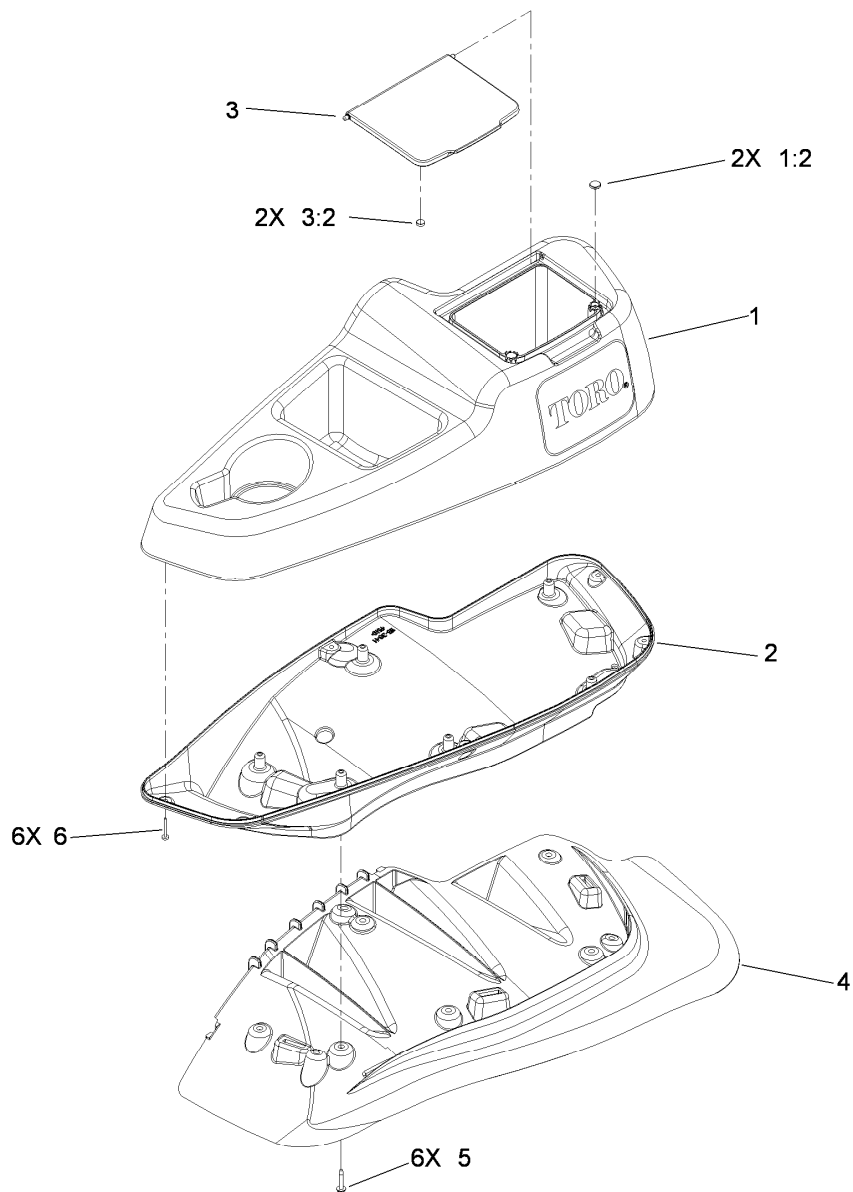

LH Console Assembly No. 115-7401

| <i>Ref.</i> | <i>Part Number</i> | <i>Qty.</i> | <i>Description</i> |
|-------------|--------------------|-------------|-------------------------|
| 1 | 114-1539 | 1 | LH Wide Console Top ASM |
| 1:2 | 117-0883 | 2 | Puck |
| 2 | 115-3641 | 1 | Console-Lwr, LH Wide |
| 3 | 114-1537 | 1 | Wide Lid ASM |
| 3:2 | 114-5896 | 2 | Magnet |
| 4 | 109-9085 | 1 | Fender-Wide, LH |
| 5 | 32144-89 | 6 | Screw-Thread Forming |
| 6 | 117-0347 | 6 | Screw-Fillister Head |

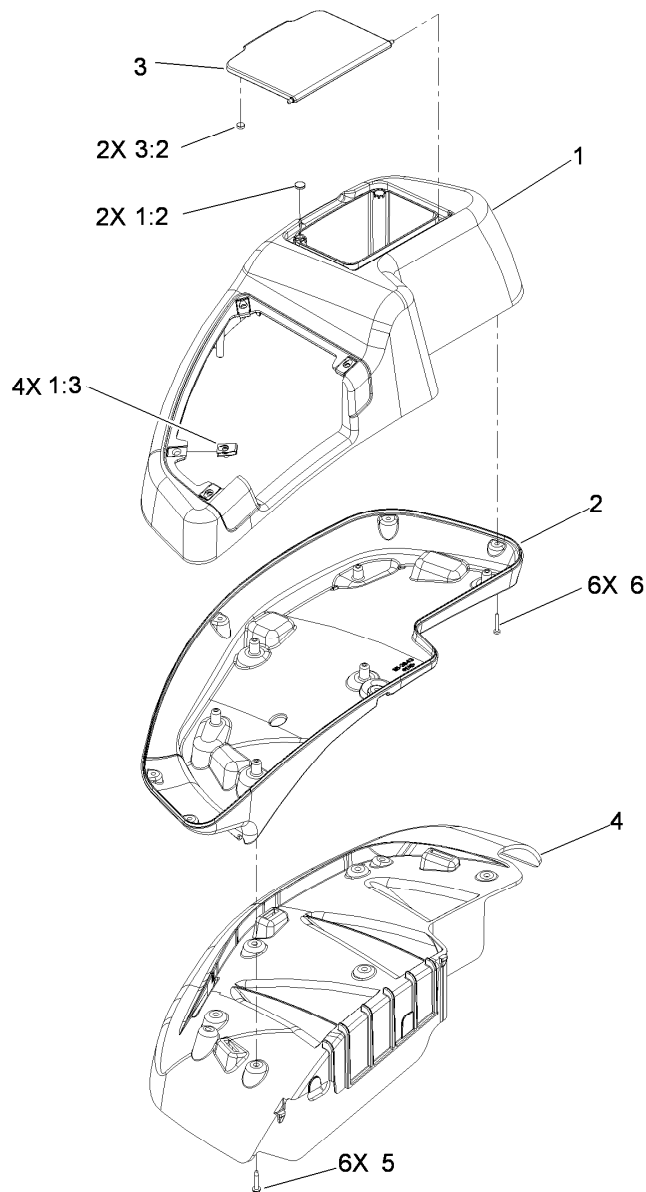

RH Console Assembly No. 115-7400

| <i>Ref.</i> | <i>Part Number</i> | <i>Qty.</i> | <i>Description</i> |
|-------------|--------------------|-------------|-------------------------|
| 1 | 114-1538 | 1 | RH Wide Top Console ASM |
| 1:2 | 117-0883 | 2 | Puck |
| 1:3 | 107069 | 4 | Clip |
| 2 | 115-3643 | 1 | Console-Lwr, RH Wide |
| 3 | 114-1537 | 1 | Wide Lid ASM |
| 3:2 | 114-5896 | 2 | Magnet |
| 4 | 109-9083 | 1 | Fender-Wide, RH |
| 5 | 32144-89 | 6 | Screw-Thread Forming |
| 6 | 117-0347 | 6 | Screw-Fillister Head |

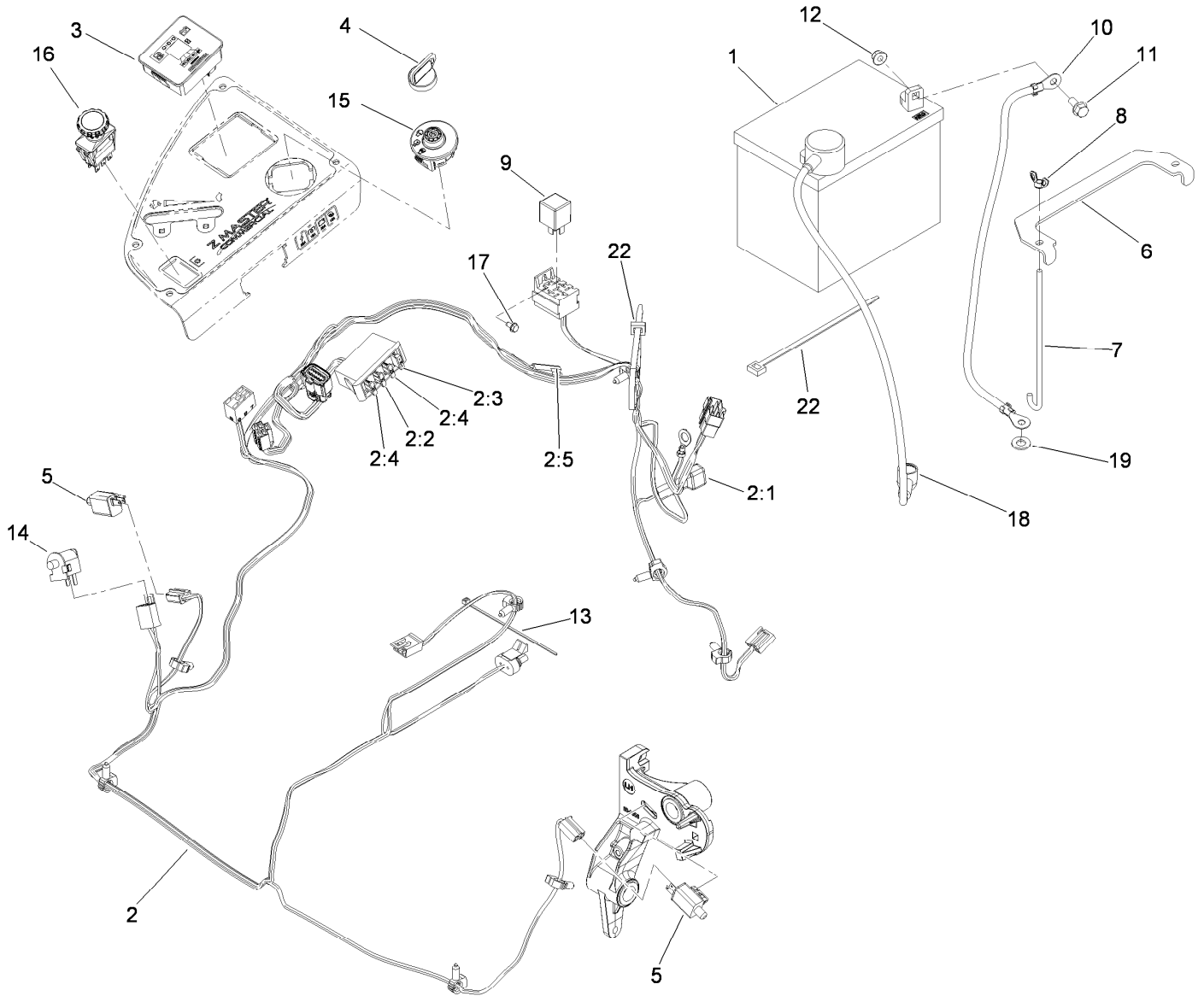

Electrical Assembly

| Ref. | Part Number | Qty. | Description | Ref. | Part Number | Qty. | Description |
|------|-------------|------|-------------------------|------|-------------|------|-------------------------|
| 1 | 104-2491 | 1 | Battery | 9 | 1-643275 | 1 | Relay |
| 2 | 115-2796 | 1 | Harness-Wire, Main | 10 | 114-1218 | 1 | Cable-Battery, Negative |
| 2:1 | 103-3895 | 1 | Diode-Tvs | 11 | 3234-5 | 2 | Screw-HHF |
| 2:2 | 218-578 | 1 | Fuse-10 Amp | 12 | 104-8300 | 2 | Nut-Flange, NI |
| 2:3 | 109355 | 1 | Fuse-15 Amp | 13 | 1-303287 | 3 | Tie-Cable |
| 2:4 | 109102 | 2 | Fuse-25 Amp | 14 | 82-2190 | 1 | Switch-Bail |
| 2:5 | 116-0053 | 1 | Cap-Plug | 15 | 117-2221 | 1 | Switch-Ignition |
| 3 | 116-1355 | 1 | Fuel/Hour Meter ASM | 16 | 116-0124 | 1 | Switch-PTO, 10A |
| 4 | 63-8360 | 1 | Key-Ignition | 17 | 104-2065 | 1 | Screw-HWH |
| 5 | 110-6765 | 2 | Switch-Single Pole No | 18 | 115-3864 | 1 | Cable-Battery, Positive |
| 6 | 116-0042-03 | 1 | Strap-Tie Down, Battery | 19 | 3256-24 | 1 | Washer-Flat |
| 7 | 1-633651 | 2 | Bolt-Holddown | 22 | 1-303335 | 1 | Tie-Plastic |
| 8 | 1-543792 | 2 | Wingnut | | | | |

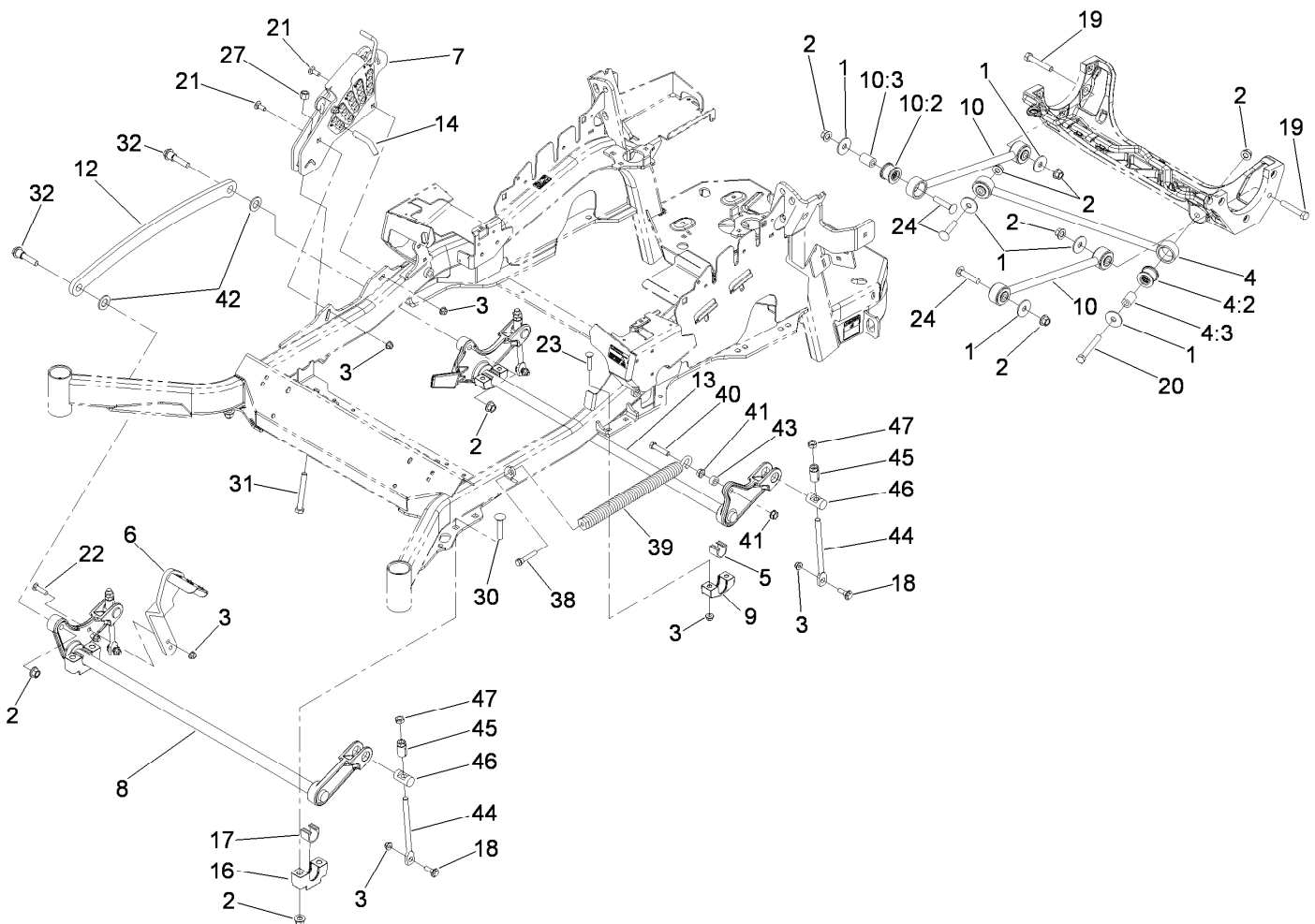

Deck Lift Assembly

| Ref. | Part Number | Qty. | Description | Ref. | Part Number | Qty. | Description |
|------|-------------|------|------------------------------------|------|-------------|------|----------------------------|
| 1 | 86-1990 | 6 | Washer | 17 | 109-9410 | 2 | Bearing-Shaft Front, Cross |
| 2 | 99-5107 | 12 | Nut-Lock | 18 | 109-9840 | 4 | Screw-Shoulder, HHF |
| 3 | 104-8301 | 12 | Nut-Flange, NI | 19 | 325-12 | 2 | Screw-HH |
| 4 | 109-5013 | 1 | Panhard Rod ASM | 20 | 325-17 | 1 | Screw-HH |
| 4:2 | 109-5009 | 2 | Bushing-Suspension, Rubber | 21 | 3231-2 | 2 | Screw-CARR |
| 4:3 | 109-5010 | 2 | Spacer | 22 | 3231-4 | 2 | Screw-CARR |
| 5 | 109-7173 | 2 | Bearing-Cross, Rear Shaft | 23 | 3231-5 | 4 | Screw-CARR |
| 6 | 116-1919-01 | 1 | Lever-Foot | 24 | 3233-34 | 3 | Screw-CARR |
| 7 | 109-7438 | 1 | Height-Of-Cut ASM | 27 | 3296-23 | 1 | Nut-Lock, NI |
| 8 | 116-1771-03 | 1 | Deck Lift-Front | 30 | 116-1700 | 4 | Screw-CARR,Spl |
| 9 | 116-0818-03 | 2 | Support-Bearing, Cross Shaft Rear | 31 | 116-0559 | 1 | Bolt-TAP |
| 10 | 109-7952 | 2 | Deck Strut ASM | 32 | 116-2022 | 2 | Screw-HHF, Shoulder |
| 10:2 | 109-5009 | 2 | Bushing-Suspension, Rubber | 38 | 92-7674 | 1 | Bolt-Shoulder |
| 10:3 | 109-5010 | 2 | Spacer | 39 | 116-0000 | 1 | Extension Spring ASM |
| 12 | 116-0797-03 | 1 | Link-Lift, Deck | 40 | 109-9065 | 1 | Screw-HH |
| 13 | 116-2645-03 | 1 | Lift-Deck, Rear | 41 | 32128-37 | 2 | Nut-HF |
| 14 | 109-8757 | 1 | Pin-HOC | 42 | 3256-28 | 2 | Washer-Flat |
| 16 | 109-9409 | 2 | Support-Cross Shaft, Bearing Front | 43 | 116-2695 | 1 | Spacer |
| | | | | 44 | 109-8007 | 4 | Link-Adjuster, Deck Lift |
| | | | | 45 | 109-7840 | 4 | Adjuster-Lift, Deck |
| | | | | 46 | 109-8353 | 4 | Trunnion |
| | | | | 47 | 3218-5 | 4 | Nut-Jam |

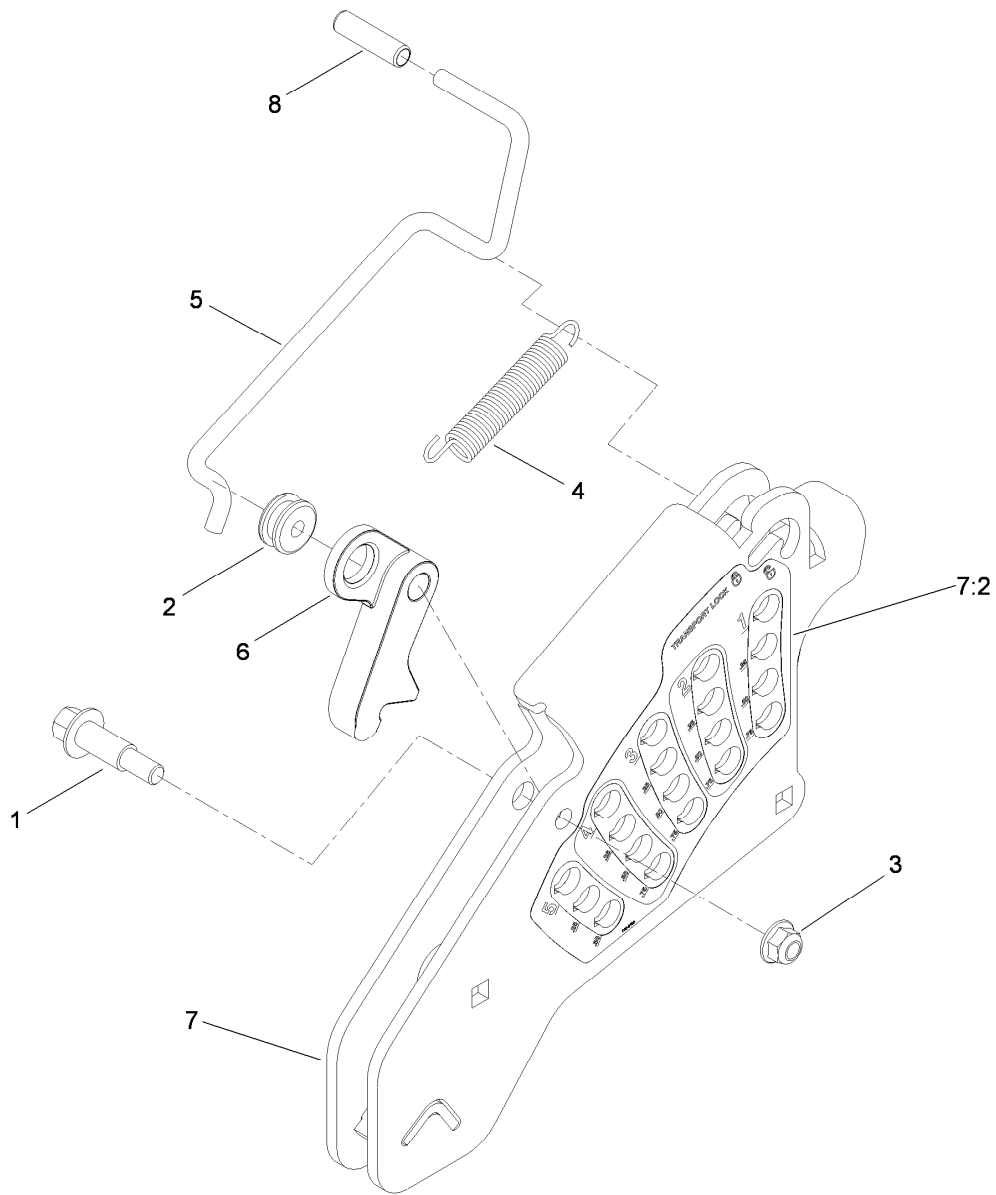

Height-of-Cut Assembly No. 109-7438

| <i>Ref.</i> | <i>Part Number</i> | <i>Qty.</i> | <i>Description</i> |
|-------------|--------------------|-------------|---------------------|
| 1 | 62-1330 | 1 | Bolt-Shoulder |
| 2 | 109-7130 | 1 | Grommet |
| 3 | 104-8301 | 1 | Nut-Flange, NI |
| 4 | 109-7124 | 1 | Spring-Extension |
| 5 | 109-7128 | 1 | Rod-Lock, Transport |
| 6 | 116-0118 | 1 | Pawl-Transport, HOC |
| 7 | 109-7335 | 1 | HOC Plate ASM |
| 7:2 | 116-0752 | 1 | Decal-HOC |
| 8 | 109-8250 | 1 | Grip-Lever |

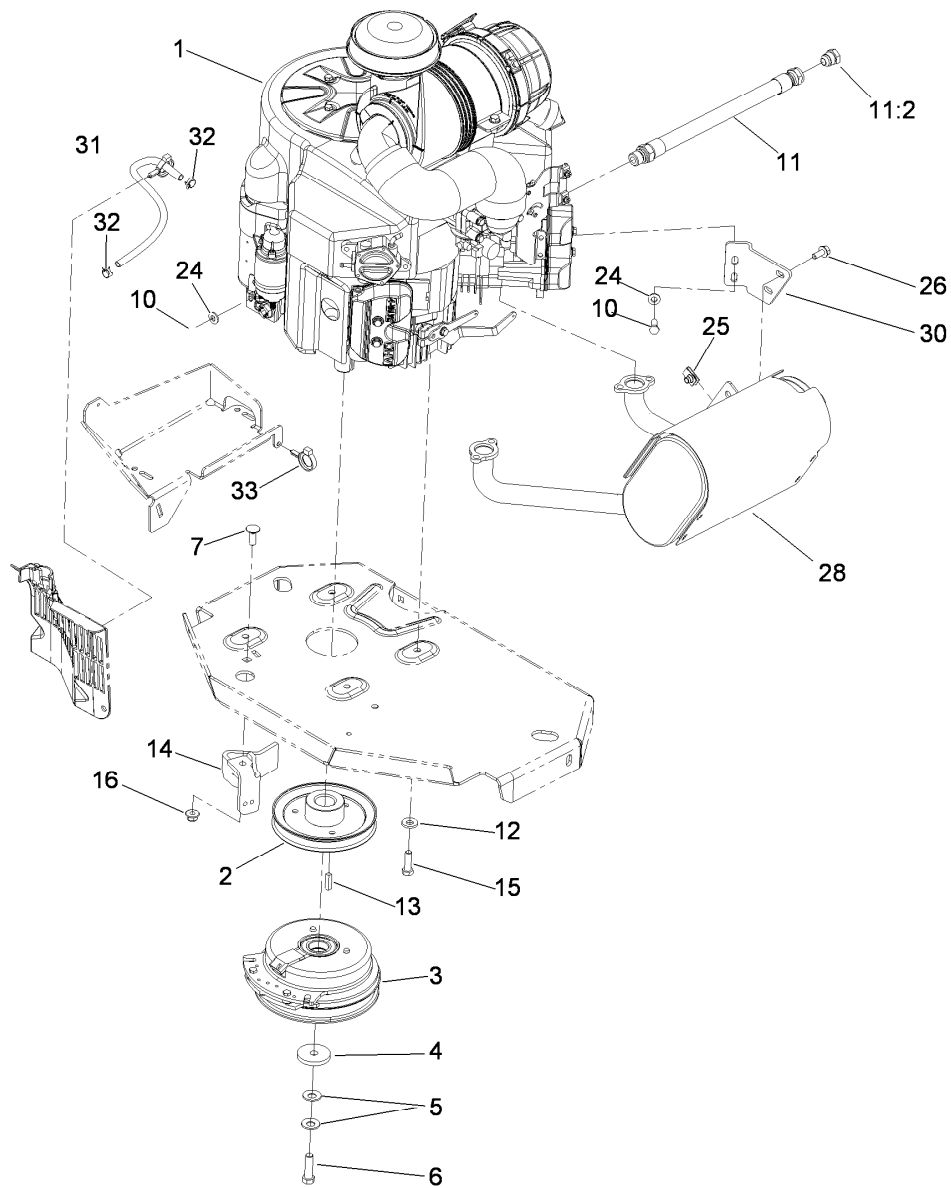

Engine, Clutch and Muffler Assembly

| Ref. | Part Number | Qty. | Description | Ref. | Part Number | Qty. | Description |
|------|-------------|------|---------------------------------|------|-------------|------|-----------------|
| 1 | | 1 | Engine-Kawasaki, Fx801V-As04 ●■ | 13 | 1-807259 | 1 | Key |
| 2 | 109-9905 | 1 | Sheave | 14 | 116-2612-01 | 1 | Clutch-Anchor |
| 3 | 116-1620 | 1 | Clutch Kit | 15 | 323-7 | 4 | Screw-HH |
| 4 | 109-6919 | 1 | Washer-Clutch | 16 | 104-8301 | 1 | Nut-Flange, NI |
| 5 | 1-603610 | 2 | Washer-Spring | 24 | 1-303334 | 3 | Washer-Spring |
| 6 | 109-9761 | 1 | Screw-HH W/Loctite | 25 | 94-2413 | 2 | U-Nut |
| 7 | 3231-22 | 1 | Screw-CARR | 26 | 3234-5 | 2 | Screw-HHF |
| 10 | 33114-020 | 3 | Screw-HH | 28 | 116-1712 | 1 | Muffler |
| 11 | 109-4490 | 1 | Oil Drain Hose ASM | 30 | 116-0203 | 1 | Bracket-Muffler |
| 11:2 | 109-1012 | 1 | Plug | 31 | 109-0296 | 1 | Hose-Fuel |
| 12 | 98-5975 | 4 | Washer-Belleville | 32 | 2412-98 | 2 | Clamp |
| | | | | 33 | 105-1853 | 1 | Clamp-Hose |

● Not serviced separately

■ Obtain parts from www.kawpowerepc.com

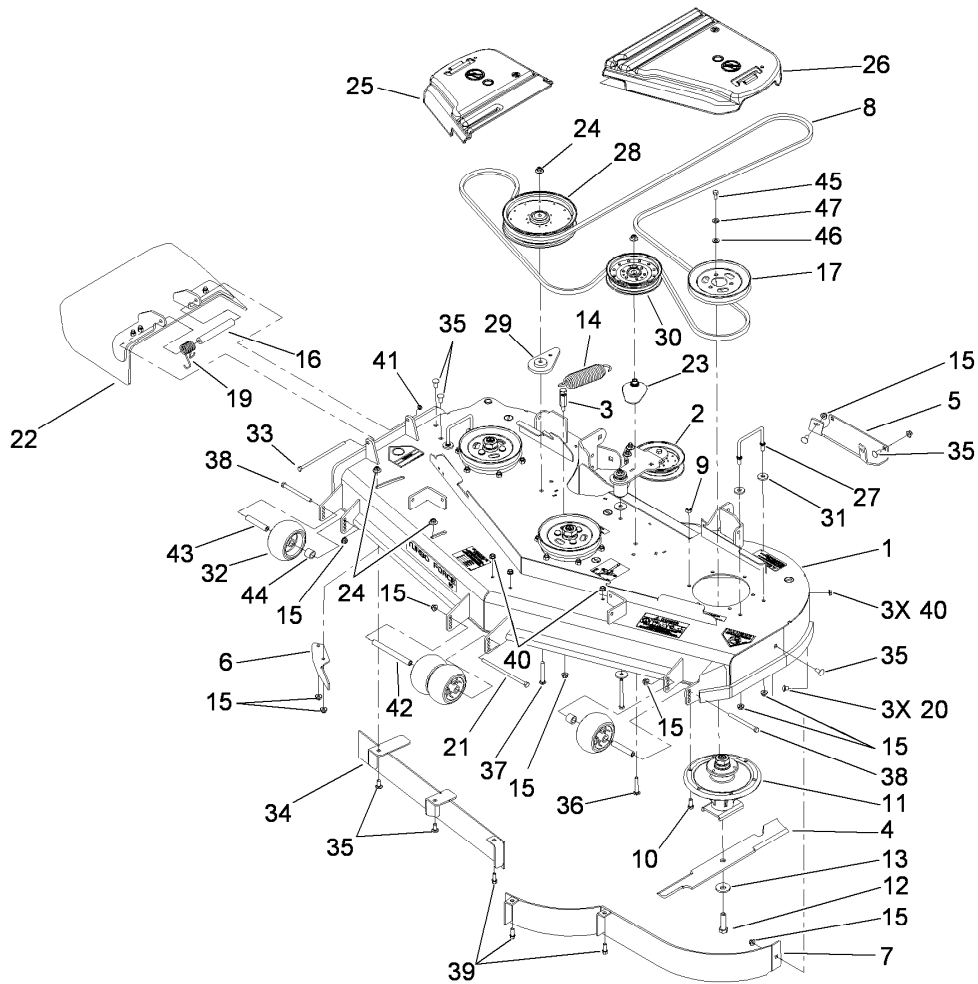

Deck Assembly

| <i>Ref.</i> | <i>Part Number</i> | <i>Qty.</i> | <i>Description</i> | <i>Ref.</i> | <i>Part Number</i> | <i>Qty.</i> | <i>Description</i> |
|-------------|--------------------|-------------|--------------------------|-------------|--------------------|-------------|--------------------|
| 1 | 114-5815 | 1 | Deck Decal ASM | 25 | 116-0094 | 1 | Cover-Belt, RH |
| 2 | 114-5875 | 1 | Idler Arm ASM | 26 | 109-6938 | 1 | Cover-Belt, LH |
| 3 | 114-5867 | 1 | Anchor-Spring, Tall | 27 | 109-6982 | 2 | Wireform-Cover |
| 4 | 105-7718-03 | 3 | Blade-Hi Flow | 28 | 109-8590 | 1 | Pulley-Idler |
| 5 | 105-8792-01 | 1 | Plate-Skid | 29 | 109-9416 | 1 | Spacer-Idler |
| 6 | 106-3216-01 | 1 | Baffle-Discharge | 30 | 114-5895 | 1 | Pulley-Idler, Flat |
| 7 | 114-5842-01 | 1 | Baffle ASM | 31 | 1-373034 | 4 | Washer |
| 8 | 114-5858 | 1 | Belt-V | 32 | 1-603299 | 4 | Roller-Scalp, Anti |
| 9 | 33025-00 | 18 | Nut-Lock | 33 | 322-50 | 1 | Screw-HH |
| 10 | 33115-025 | 18 | Screw-HH | 34 | 115-7465-01 | 1 | Baffle ASM |
| 11 | 117-3840 | 3 | Spindle ASM | 35 | 3231-27 | 9 | Screw-CARR |
| 12 | 51-4060 | 3 | Screw-Blade | 36 | 3231-40 | 1 | Bolt-CARR |
| 13 | 103-0865 | 3 | Washer-Blade Bolt, Heavy | 37 | 3231-42 | 1 | Screw-CARR |
| 14 | 116-0133 | 1 | Extension-Spring | 38 | 323-23 | 2 | Screw-HH |
| 15 | 104-8301 | 15 | Nut-Flange, NI | 39 | 92-1624 | 3 | Screw-HWH |
| 16 | 105-4622 | 1 | Spacer | 40 | 3290-357 | 6 | Nut-HHF, Whiz |
| 17 | 105-7734 | 3 | Pulley | 41 | 3296-47 | 1 | Nut-Lock, NI |
| 19 | 108-4052 | 1 | Spring-Torsion | 42 | 98-5967 | 1 | Spacer-Wheel |
| 20 | 108-5387 | 3 | Screw-CARR | 43 | 98-7912 | 2 | Tube-Spanner |
| 21 | 108-5388 | 1 | Screw-HH | 44 | 98-7913 | 2 | Tube-Spacer |
| 22 | 108-7770 | 1 | Rubber Deflector ASM | 45 | 323-4 | 9 | Screw-HH |
| 23 | 109-2872 | 1 | Spacer-Pulley | 46 | 3256-24 | 9 | Washer-Flat |
| 24 | 109-6658 | 4 | Nut-Flange, NI | 47 | 3290-455 | 9 | Washer-Belleville |

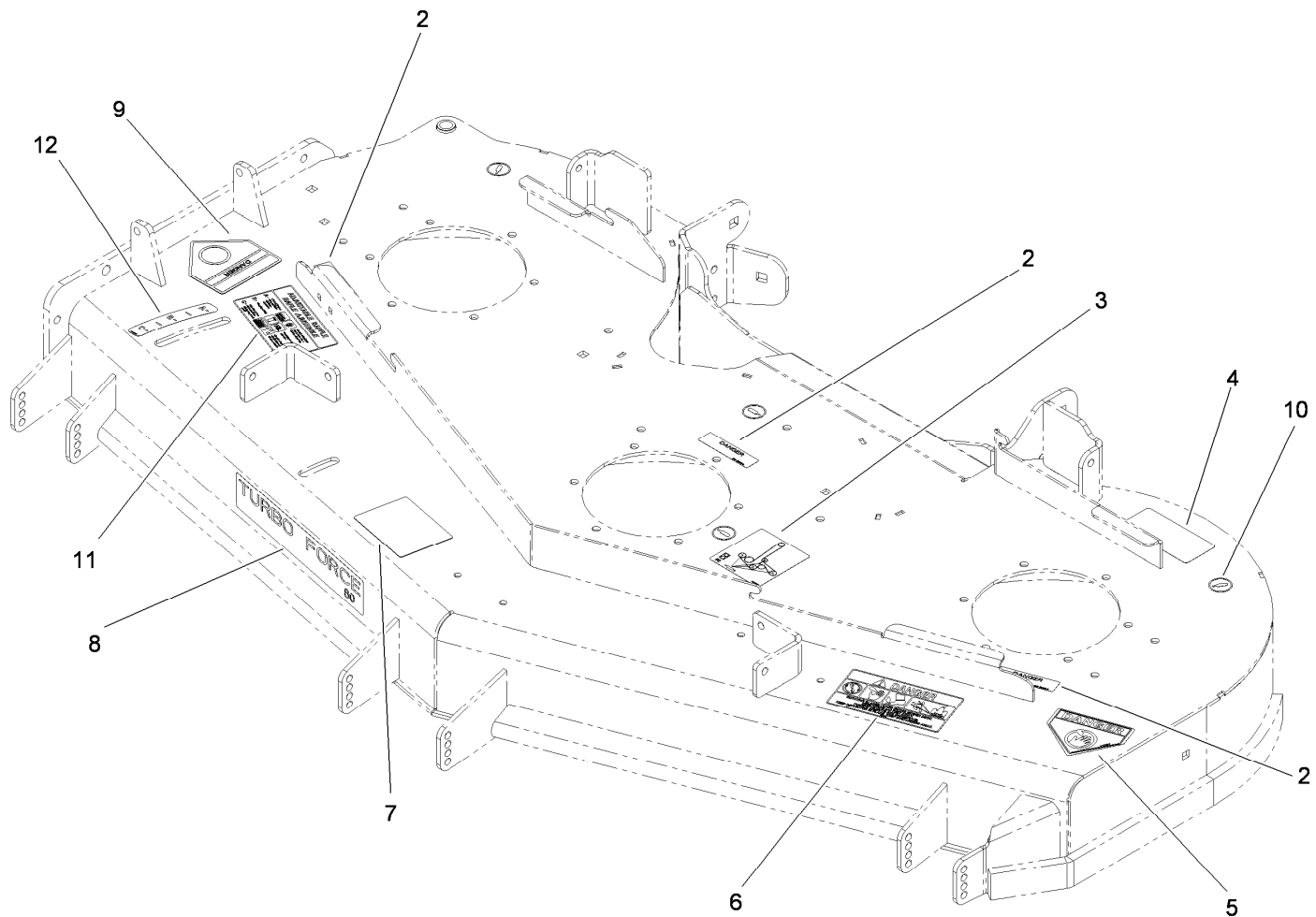

Deck Decal Assembly No. 114-5815

| <i>Ref.</i> | <i>Part Number</i> | <i>Qty.</i> | <i>Description</i> |
|-------------|--------------------|-------------|-----------------------------|
| 2 | 98-5954 | 3 | Decal-Cover, Missing |
| 3 | 115-7445 | 1 | Decal-Routing, Deck Belt |
| 4 | 68-8340 | 1 | Decal-Torque |
| 5 | 1-403005 | 1 | Decal-Danger |
| 6 | 66-1340 | 1 | Decal-Danger, Thrown Object |
| 7 | 105-7798 | 1 | Decal-Scalp, Anti |
| 8 | 107-1619 | 1 | Decal |
| 9 | 54-9220 | 1 | Decal-Danger |
| 10 | 58-6520 | 4 | Decal-Grease |
| 11 | 110-2068 | 1 | Decal-Adjustment, Baffle |
| 12 | 110-2067 | 1 | Decal-Setting, Baffle |

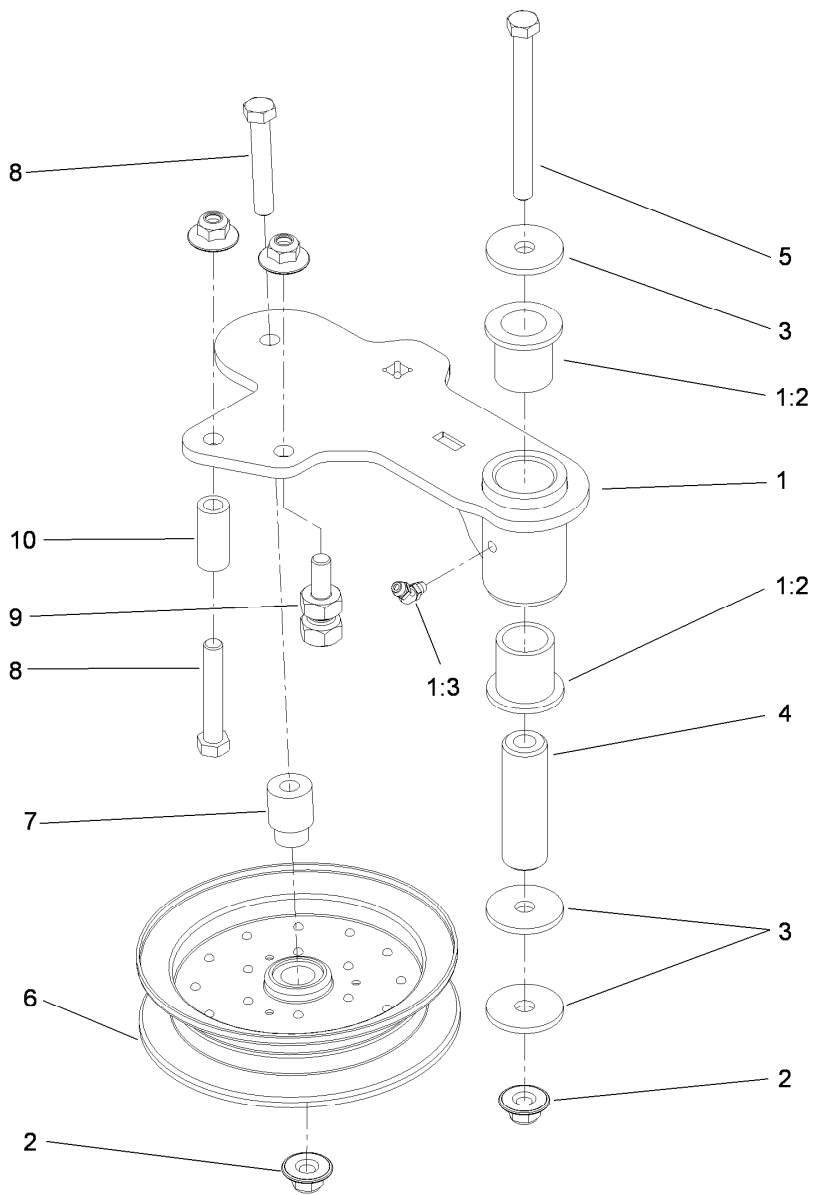

Idler Assembly

| Ref. | Part Number | Qty. | Description |
|------|-------------|------|-----------------------|
| 1 | 114-5870 | 1 | Idler Arm ASM |
| 1:2 | 1-303514 | 2 | Bearing-Flanged |
| 1:3 | 1481 | 1 | Fitting-Grease |
| 2 | 109-6658 | 4 | Nut-Flange, NI |
| 3 | 1-213069 | 3 | Washer |
| 4 | 114-5848 | 1 | Spacer-Plain |
| 5 | 98-5961 | 1 | Screw-HH |
| 6 | 103-8743 | 1 | Pulley-Idler, Flanged |
| 7 | 112-4212 | 1 | Mount-Pulley |
| 8 | 323-11 | 2 | Screw-HH |
| 9 | 114-5866 | 1 | Anchor-Spring, Short |
| 10 | 104-0151 | 1 | Spacer |

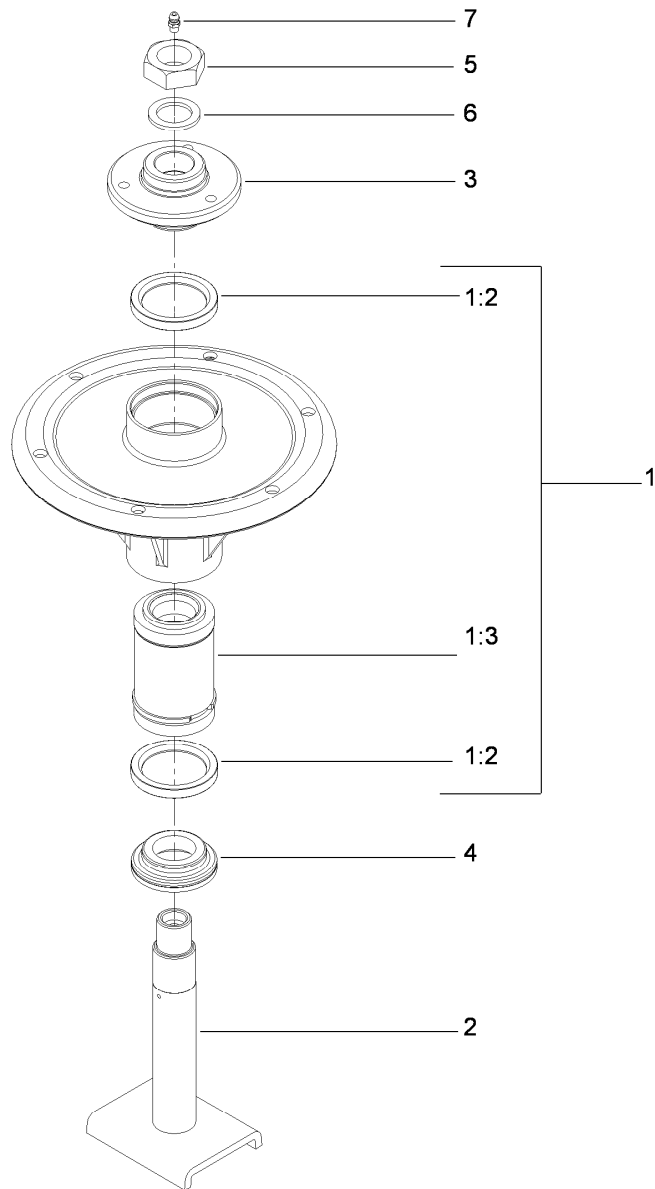

Spindle Assembly No. 117-3840

| <i>Ref.</i> | <i>Part Number</i> | <i>Qty.</i> | <i>Description</i> |
|-------------|--------------------|-------------|-----------------------|
| 1 | | 1 | Spindle Bearing ASM ● |
| 1:2 | 253-154 | 2 | Seal-Oil |
| 1:3 | 71-2530 | 1 | Bearing/Spacer Kit |
| 2 | 117-3841 | 1 | Spindle Shaft ASM |
| 3 | 114-1161 | 1 | Hub-Spline |
| 4 | 69-6950 | 1 | Spacer-Shaft, Spindle |
| 5 | 3296-49 | 1 | Nut-Lock, NI |
| 6 | 3-8514 | 1 | Washer-Thrust |
| 7 | 302-57 | 1 | Fitting-Grease |

● Not serviced separately

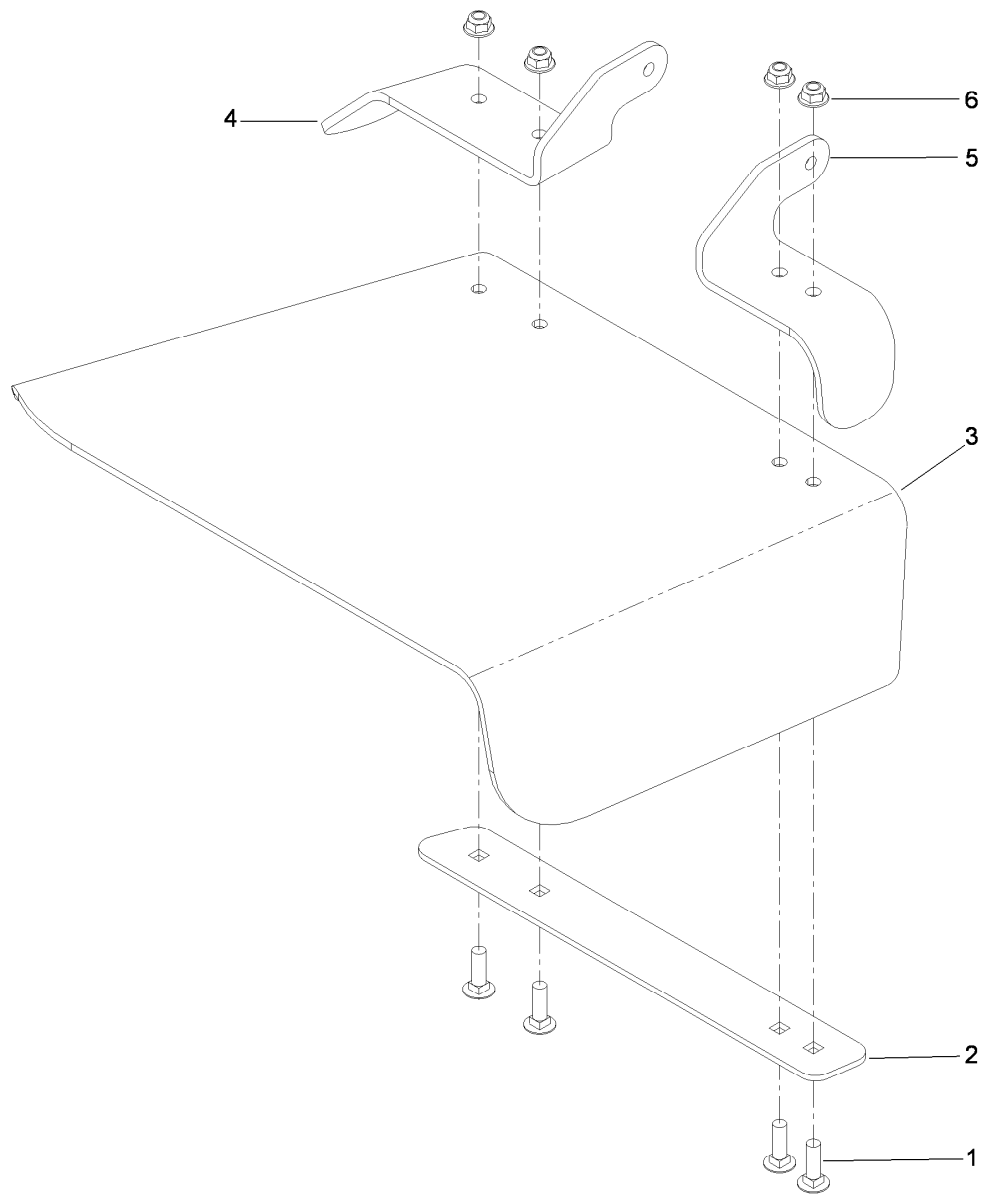

Rubber Deflector Assembly No. 108-7770

| <i>Ref.</i> | <i>Part Number</i> | <i>Qty.</i> | <i>Description</i> |
|-------------|--------------------|-------------|----------------------|
| 1 | 3231-25 | 4 | Screw-CARR |
| 2 | 106-3248-03 | 1 | Strap-Discharge |
| 3 | 108-5029 | 1 | Deflector-Rubber |
| 4 | 108-7767-03 | 1 | Bracket-Hinge, Rear |
| 5 | 108-7766-03 | 1 | Bracket-Hinge, Front |
| 6 | 104-8301 | 4 | Nut-Flange, NI |

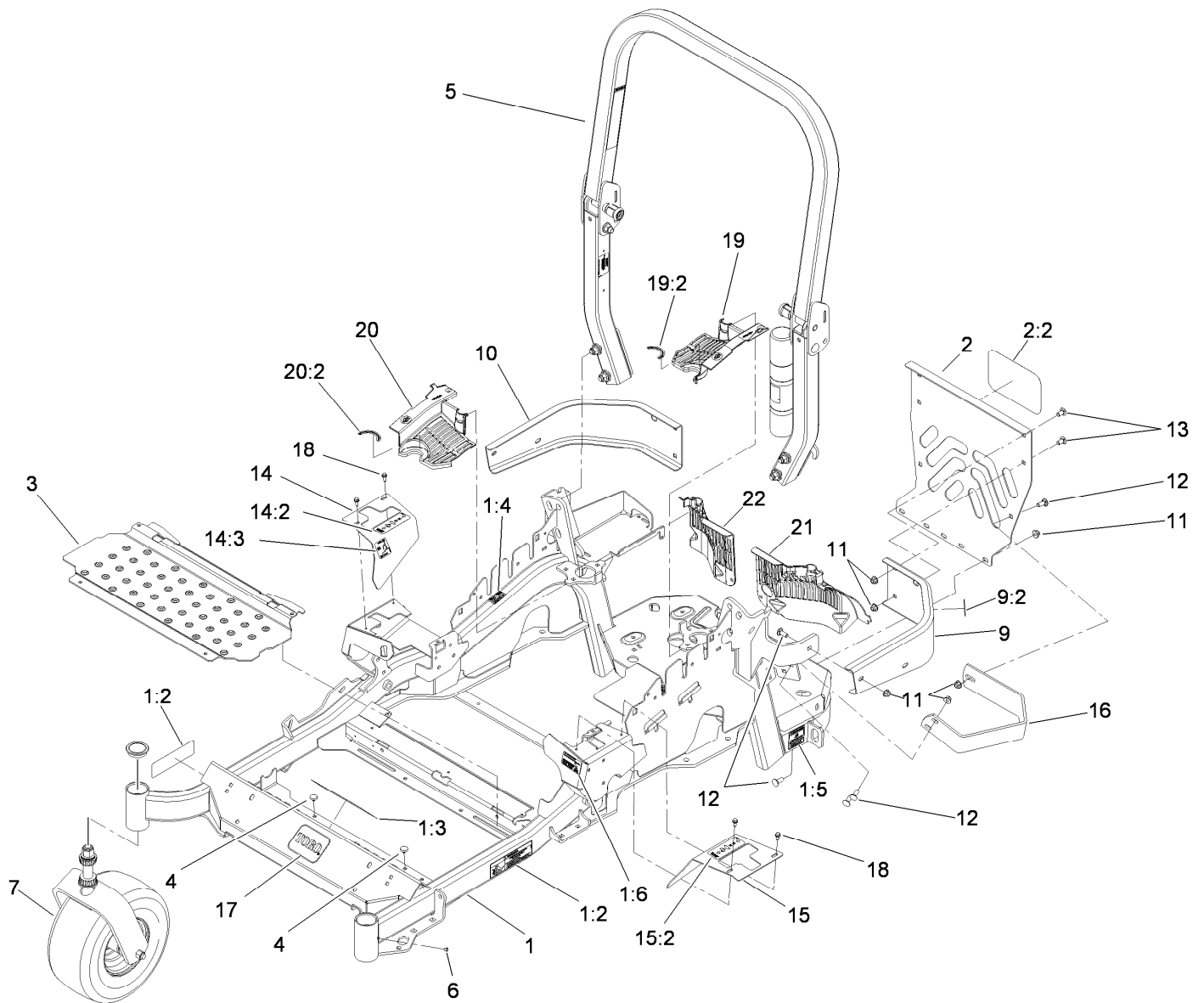

Front Frame and Caster Wheel Assembly

| Ref. | Part Number | Qty. | Description | Ref. | Part Number | Qty. | Description |
|------|-------------|------|-----------------------|------|-------------|------|-----------------------------|
| 1 | 116-2126 | 1 | Main Frame ASM | 13 | 3231-21 | 4 | Screw-CARR |
| 1:2 | 107-2112 | 1 | Decal-Warning | 14 | 116-0579 | 1 | RH Motion Control Cover ASM |
| 1:3 | 103-2076 | 2 | Decal-Caution | 14:2 | 109-7232 | 1 | Decal-Motion Control |
| 1:4 | 116-0205 | 2 | Decal-Belt Drive | 14:3 | 109-7929 | 1 | Decal-Park Brake |
| 1:5 | 117-2718 | 1 | Decal-Arrester, Spark | 15 | 116-0580 | 1 | LH Motion Control Cover ASM |
| 1:6 | 116-1654 | 1 | Decal Fuel Fill | 15:2 | 109-7232 | 1 | Decal-Motion Control |
| 2 | 115-7410 | 1 | Rear Guard ASM | 16 | 116-0043-03 | 1 | Guard-Muffler |
| 2:2 | 67-7320 | 1 | Decal | 17 | 68-3640 | 1 | Decal |
| 3 | 116-0024-01 | 1 | Floorpan | 18 | 32144-10 | 4 | Screw-HWH |
| 4 | 1-513658 | 2 | Bumper | 19 | 116-0170 | 1 | LH Hydro Guard ASM |
| 5 | 116-0232 | 1 | ROPS ASM | 19:2 | 116-0157 | 1 | Decal-Hydro Oil |
| 6 | 1-811010 | 2 | Plug | 20 | 116-0171 | 1 | RH Hydro Guard ASM |
| 7 | | 2 | Caster Wheel ASM ● | 20:2 | 116-0157 | 1 | Decal-Hydro Oil |
| 9 | 109-9869 | 1 | Bumper-Rear, LH | 21 | 109-9057 | 1 | Guard-Hydro, Rear LH |
| 9:2 | 103-2076 | 1 | Decal, Hot Surface | 22 | 109-9058 | 1 | Guard-Hydro, Rear RH |
| 10 | 116-0057-03 | 1 | Bumper-RH | | | | |
| 11 | 104-8301 | 11 | Nut-Flange, NI | | | | |
| 12 | 3231-22 | 7 | Screw-CARR | | | | |

● Not serviced separately

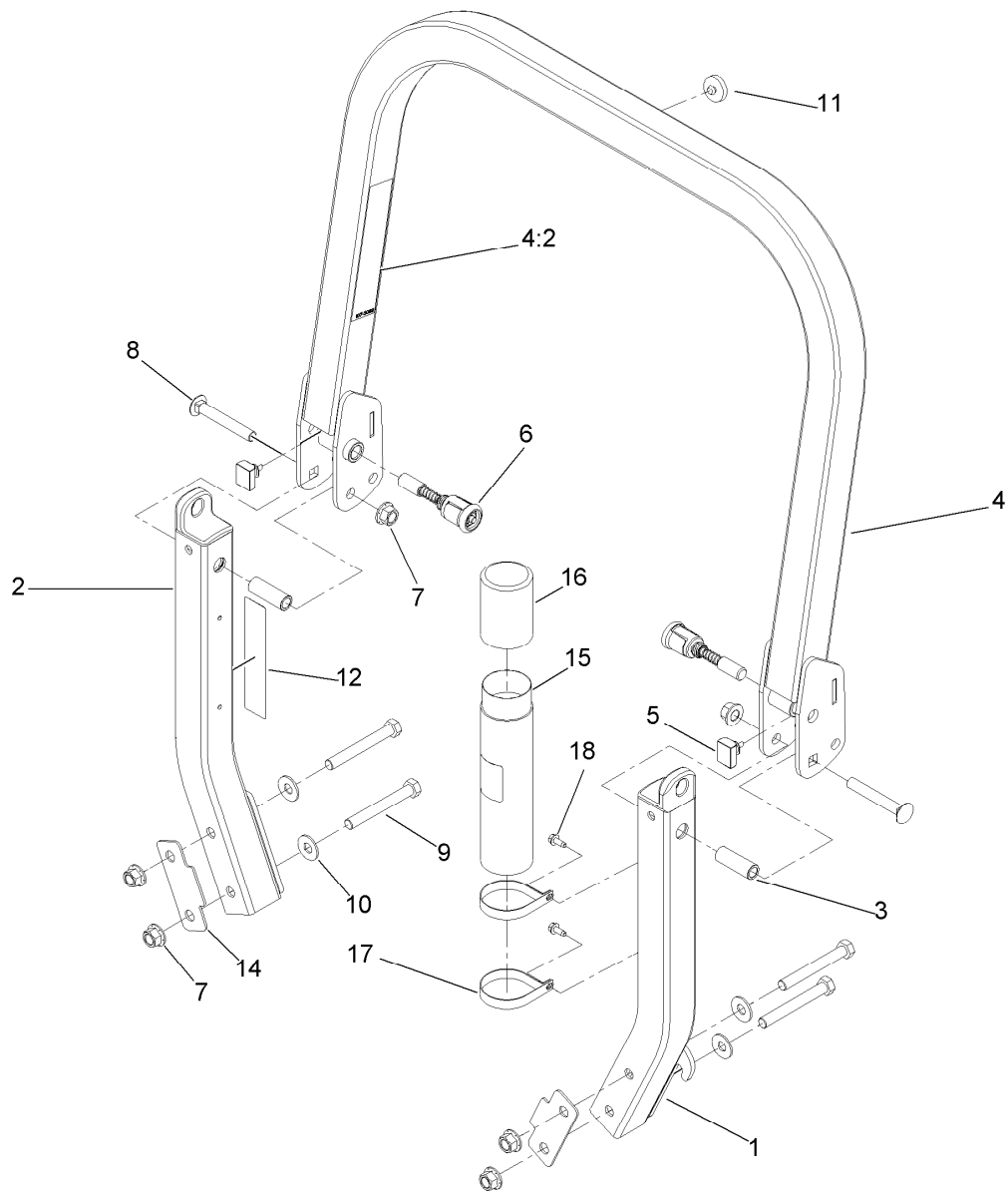

Roll-Over Protection System Assembly No. 116-0232

| Ref. | Part Number | Qty. | Description | Ref. | Part Number | Qty. | Description |
|------|-------------|------|-----------------------------|------|-------------|------|--------------------------|
| 1 | | 1 | Leg-ROPS, LH ● | 9 | 325-17 | 4 | Screw-HH |
| 2 | | 1 | Leg-ROPS, RH ● | 10 | 109-9505 | 4 | Washer-Spring |
| 3 | 109-6653 | 2 | Spacer | 11 | 109-9233 | 1 | Bumper-Push-In, Rubber |
| 4 | | 1 | Upper ROPS ASM ● | 12 | 117-0346 | 1 | Decal-Caution, Fuel Vent |
| 4:2 | 107-3069 | 1 | Decal-Warning, Folding ROPS | 14 | 116-0960 | 2 | Spacer |
| 5 | 109-5337 | 2 | Bumper-ROPS | 15 | 104-7050 | 1 | Tube-Manual |
| 6 | 116-0104 | 2 | Spring Pin ASM | 16 | 104-7048 | 1 | Cap-Housing |
| 7 | 99-5107 | 6 | Nut-Lock | 17 | 107-1865 | 2 | R-Clamp |
| 8 | 3233-10 | 2 | Screw-CARR | 18 | 32144-10 | 2 | Screw-HWH |

● Not serviced separately

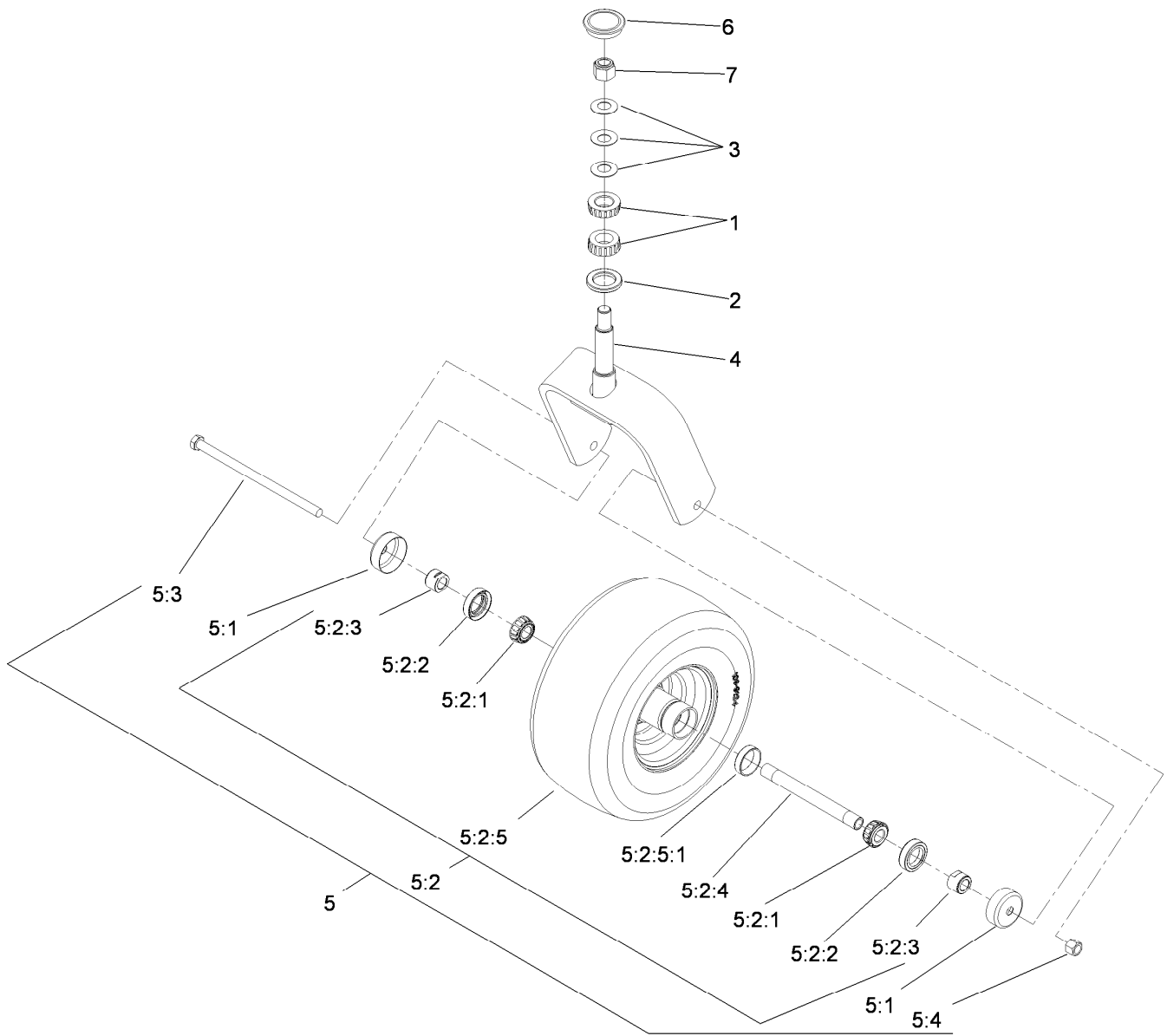

Caster Wheel and Fork Assembly

| <i>Ref.</i> | <i>Part Number</i> | <i>Qty.</i> | <i>Description</i> |
|-------------|--------------------|-------------|-------------------------|
| 1 | 1-543509 | 2 | Bearing-Roller, Tapered |
| 2 | 1-543511 | 1 | Seal-Grease |
| 3 | 1-633508 | 3 | Washer-Bellville |
| 4 | 103-1474-01 | 1 | Caster-Fork |
| 5 | 109-9127 | 1 | Wheel And Tire ASM |
| 5:1 | 103-2768 | 2 | Guard-Seal |
| 5:2 | | 1 | Wheel And Tire ASM ● |
| 5:2:1 | 1-633585 | 2 | Bearing-Cone, Taper |
| 5:2:2 | 103-0063 | 2 | Seal-Caster |

| <i>Ref.</i> | <i>Part Number</i> | <i>Qty.</i> | <i>Description</i> |
|-------------|--------------------|-------------|--------------------|
| 5:2:3 | 103-3051 | 2 | Spacer-Nut |
| 5:2:4 | 103-5156 | 1 | Axle-Caster |
| 5:2:5 | 109-9124 | 1 | Wheel And Tire ASM |
| 5:2:5:1 | 1-633584 | 1 | Bearing-Cup |
| 5:3 | 325-39 | 1 | Screw-HH |
| 5:4 | 3296-23 | 1 | Nut-Lock, NI |
| 6 | 103-4882 | 1 | Cap-Grease |
| 7 | 3296-51 | 1 | Nut-Lock, NI |

● Not serviced separately

Attachments and Accessories

For 74945CP Z Master G3 Riding Mower, with 60in TURBO FORCE Side Discharge Mower

| Product Name | Model/Part |
|-----------------------------------------------|-------------------|
| Blade-Mid Flow, 20.5 inch..... | 105-7715-03 |
| Blade-Lo Flow, 20.5 inch..... | 105-7716-03 |
| Blade-Hi Flow, 20.5 inch | 105-7718-03 |
| Blade-Recycler, 20.5 inch | 105-7777-03 |
| Blade-Atomic, 20.5 inch..... | 105-8777-03 |
| 6 Pack Blade, 20.5 inch Hi-Flow | 108-1114 |
| 6 Pack-Blade, 20.5 inch Atomic | 108-1115 |
| 6 Pack Blade, 20.5 inch Mid-Flow | 108-1123 |
| 6 Pack-Blade, 20.5 inch Lo Flow..... | 108-1128 |
| Hitch Kit | 109-9487 |
| 6 Pack-Blade, 20.5 inch Recycler | 110-0405 |
| Hypr-Oil 500 (quart) | 114-4713 |
| Hypr-Oil 500 (gallon)..... | 114-4714 |
| Hypr-Oil 500-5 (5 gallon)..... | 114-4715 |
| Bimini Folding Shade Assembly | 115-4510 |
| Recycler Kit | 115-7468 |
| Roller Striper Kit..... | 115-7470 |
| Light Kit..... | 116-1154 |
| Z Stand Kit..... | 117-0350 |
| Operator-Controlled Discharge Chute Kit | 117-3600 |
| Deluxe Suspension Seat Kit | 117-6174 |
| Toro Deluxe Rider Cover..... | 490-7319 |
| Blower and Drive Kit | 78553 |
| E-Z Vac Triple Bagging System | 78563 |
| E-Z Vac DFS Collection System | 78567 |
| Filter Minder Gauge | 99-4664 |
| Trash Holder Kit..... | TC26 |

Notes:



Count on it.