



Count on it.

Parts Catalog

**TITAN ZX4820 Zero-Turn-Radius
Riding Mower**

Model No. 74841—Serial No. 311000001 and Up

Ordering Replacement Parts

To order replacement parts, please supply the part number, the quantity, and the description of each part desired.

Understanding Reference Numbers

Each identified part in an illustration has a reference number. The reference number for a part also appears in the parts list, along with other information about the part.

This catalog uses two special reference number formats, one to indicate parts in a service assembly and another to indicate the quantity of a given part in an illustration.

Service Assembly Reference Numbers

Parts in service assemblies have reference numbers in the form a:b. The a represents the reference number of the entire service assembly and the b represents a sequential number unique to each part within the service assembly.

For example, a wheel assembly might be identified by reference number 6, the tire by 6:1, the valve by 6:2, and the wheel by 6:3. When you order the assembly identified by reference number 6, you receive all parts identified by reference numbers 6:1, 6:2, and 6:3. However, you may also order any part individually. Reference numbers of this type appear in illustration and in parts lists.

Reference Numbers Indicating Quantity

In an illustration, if a reference number indicates more than one part, the reference number has the form nX y. The n represents the quantity of the part, the X is the multiplication symbol, and the y represents the reference number.

For example, in an illustration, the reference number 2X 37 means that two of the parts identified by reference number 37 are indicated.

List of Abbreviations

AR: as required

ASM: assembly

BBC: blade brake control

BHTF: button head thread forming

CARR: carriage

CCW: counter clockwise

CW: clockwise

DEG: degrees

DPA: Dual Point Adjustment

ECM: electronic control module

EXT: external

FH: flat head

GA: gauge

HD: heavy-duty

HF: hex flange

HH: hex head

HHF: hex head flange

HHFTF: hex head flange thread forming

HJ: hex jam

HLH: hex lag head

HOC: height-of-cut

HSBH: hex socket button head

HSFH: hex socket flat head

HSH: hex socket head

HWH: hex washer head

HWHTF: hex washer head thread forming

HYD: hydraulic

LH: left hand

LP: Liquid Propane

NI: nylon insert

NPTF: national pipe thread fine

PFH: phillips flat head

PPH: phillips pan head

PPHTF: phillips pan head thread forming

PRH: phillips round head

PTH: phillips truss head

PTO: power-take-off

RH: right hand

ROPS: roll-over protection system

RRB: rear roller brush

SFH: slotted fillister head

SHH: slotted hex head

SHWH: slotted hex washer head

SPH: slotted pan head

SQH: square head

SRH: slotted round head

STD: standard

TAP: self tapping

TTH: torx truss head

Contents

Main Frame Assembly	4
Wheel and Tire Assembly No. 115-2554	5
Control Panel and Body Styling Pod Assembly	6
Deck Lift Assembly	7
Seat Assembly	8
Traction Drive Assembly	9
RH Hydro Assembly No. 115-2550	10
LH Hydro Assembly No. 115-2551	12
Motion Control Assembly	14
Brake Link Assembly	16
Engine, Muffler and Clutch Assembly	17
Fuel Delivery Assembly	18
Multi Layer Fuel Tank Assembly No. 117-7352	19
Roll-Over Protection System Assembly	20
Electrical Assembly	21
48 Inch Deck Assembly	22
48 Inch Deck Decal Assembly No. 119-3383	23
48 Inch Deck Belt, Spindle and Hi-Flo Blade Assembly	24
Attachments and Accessories	25

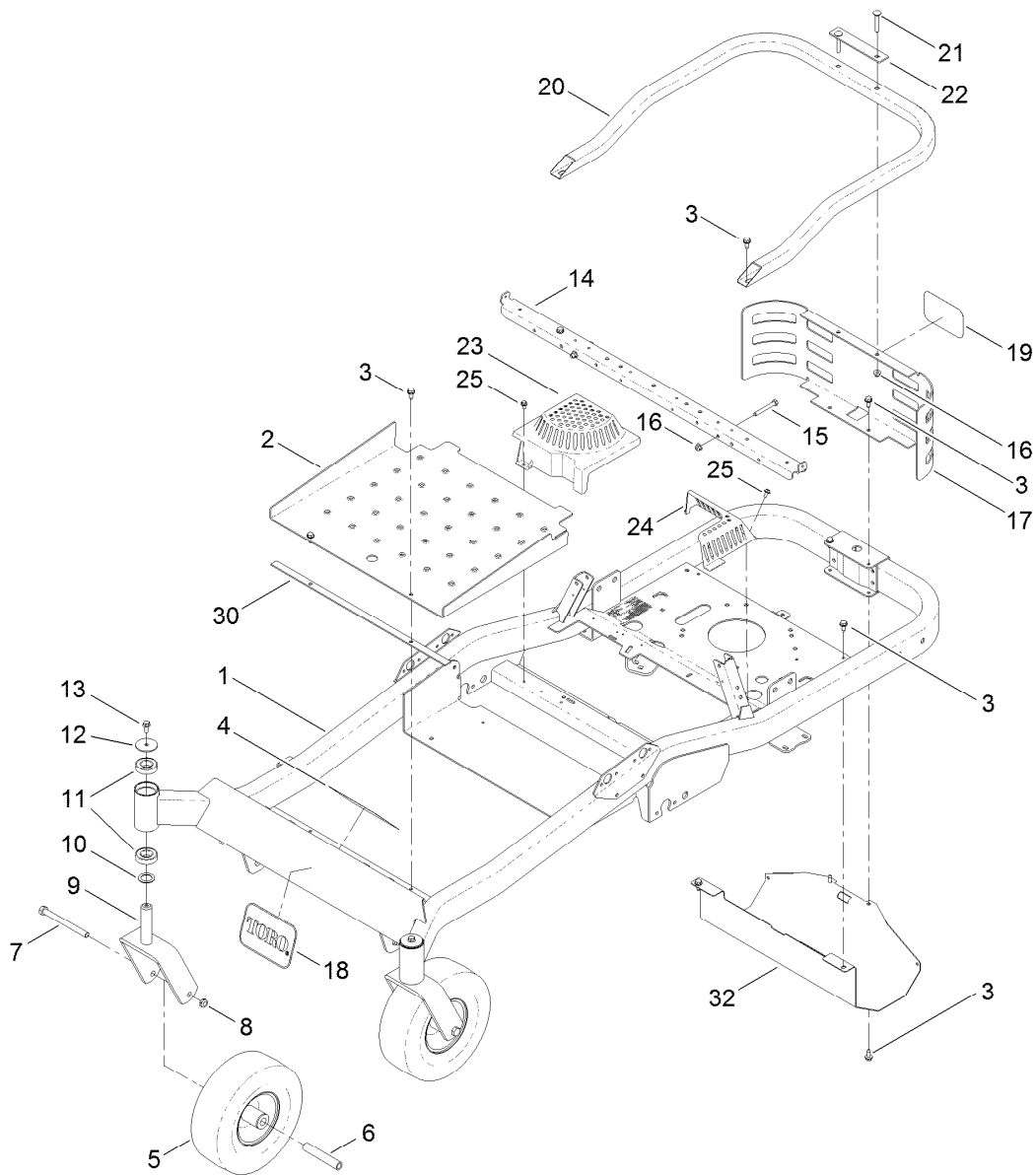

Main Frame Assembly

<i>Ref.</i>	<i>Part Number</i>	<i>Qty.</i>	<i>Description</i>	<i>Ref.</i>	<i>Part Number</i>	<i>Qty.</i>	<i>Description</i>
1	117-7356-01	1	Frame ASM	15	322-12	2	Screw-HH
2	115-2531-05	1	Pan-Floor	16	104-8300	4	Nut-Flange, NI
3	32144-70	10	Screw-HWHTF	17	120-2248-03	1	Guard-Rear
4	120-5466	1	Decal-Safety	18	62-5550	1	Decal
5	115-2554	2	Wheel And Tire ASM	19	105-8278	1	Decal
6	104-3667	2	Spanner-Wheel	20	115-2565-01	1	Guard-Rear, Tube
7	325-22	2	Screw-HH	21	3230-6	2	Screw-CARR
8	3296-45	2	Nut-Lock, NI	22	115-5061-01	1	Plate-Spacer
9	110-6634-01	2	Caster Fork ASM	23	117-1241	1	Cover-Fan, RH
10	10-8110	2	Washer-Thrust	24	117-1242	1	Cover-Fan, LH
11	109-3678	4	Bearing-Ball	25	46-8560	2	Screw-HHFTF
12	109-3724	2	Washer	30	117-7238	1	Strip-Vibration, Anti
13	3234-47	2	Screw-HHF	32	120-2247-03	1	Guard-Muffler
14	119-8997-03	1	Support-Seat				

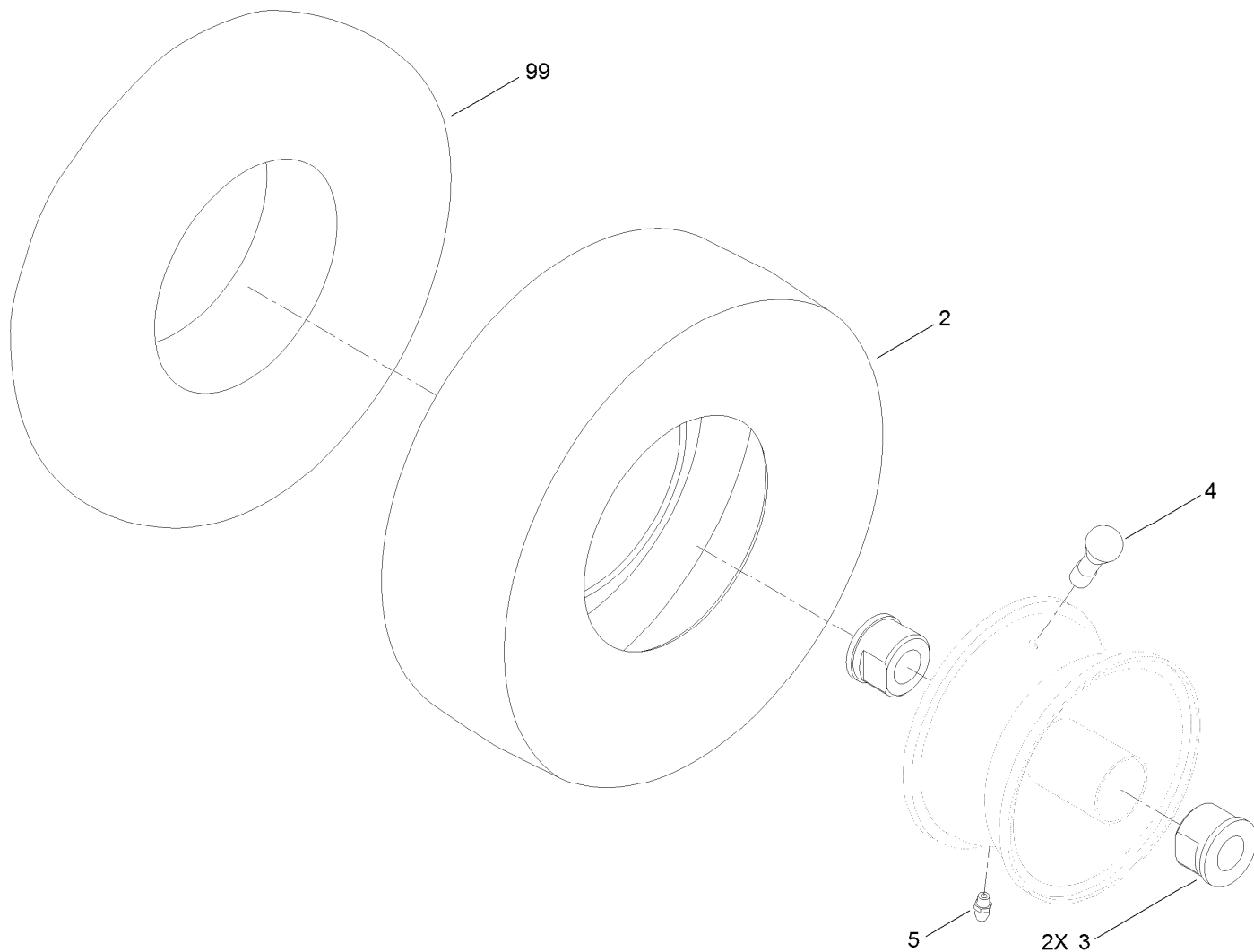

Wheel and Tire Assembly No. 115-2554

<i>Ref.</i>	<i>Part Number</i>	<i>Qty.</i>	<i>Description</i>
2	115-2557	1	Tire-Smooth
3	114-1640	2	Bushing-Flange
4	232-27	1	Stem-Valve
5	302-5	1	Fitting-Grease
99	117-1234	1	Tube-Inner

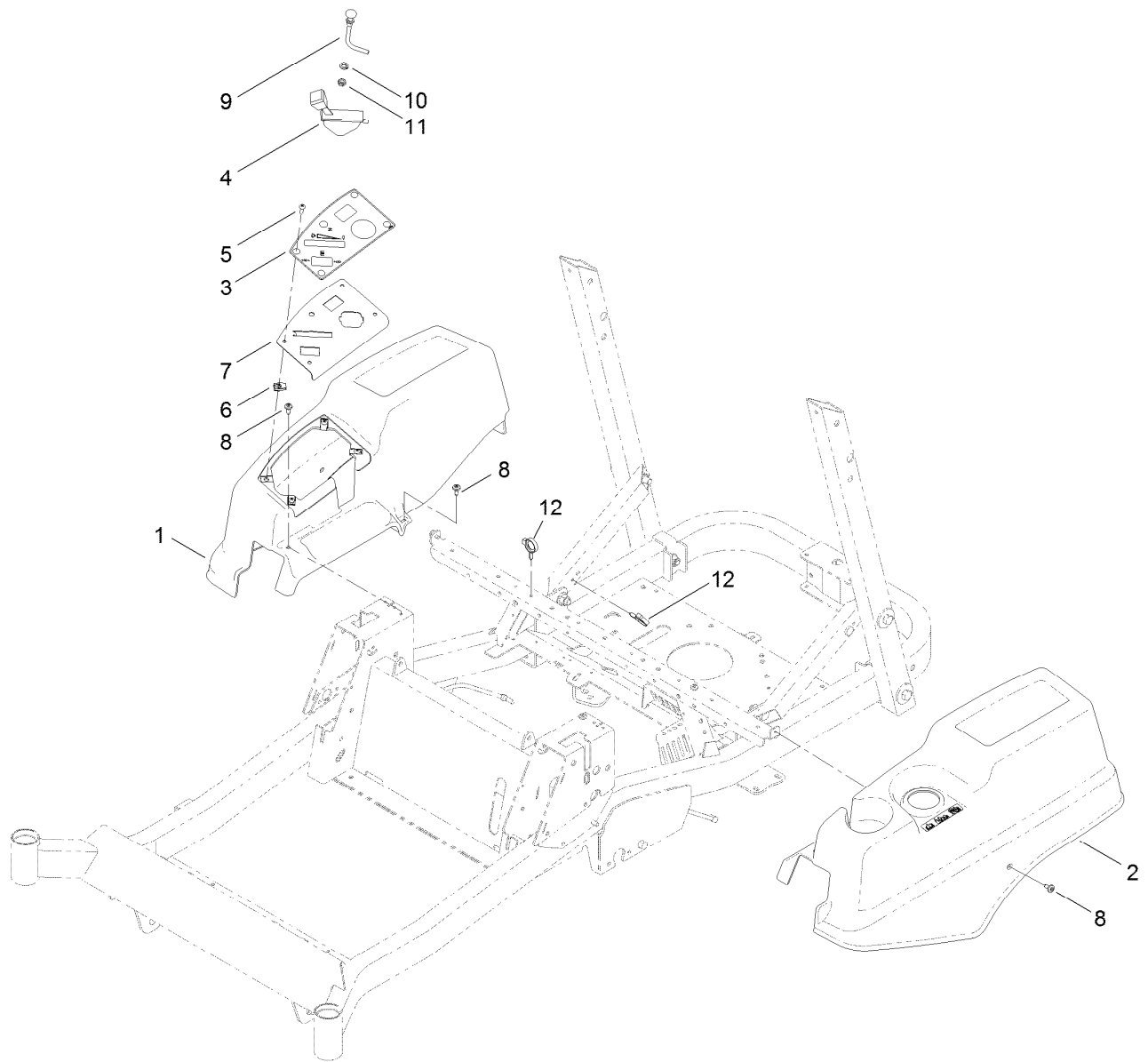

Control Panel and Body Styling Pod Assembly

<i>Ref.</i>	<i>Part Number</i>	<i>Qty.</i>	<i>Description</i>
1	115-2581	1	Pod-RH
2	115-2582	1	Pod-LH
3	115-9632	1	Decal-Panel, Control
4	120-2290	1	Cable-Throttle
5	3258-166	4	Screw-PRH
6	107069	4	Clip
7	115-2591-03	1	Panel-Control
8	112-4004	6	Screw-Shoulder
9	120-2291	1	Cable-Choke
10	3253-21	1	Washer-Lock
11	3220-3	1	Nut-HJ
12	105-1853	2	Clamp-Hose

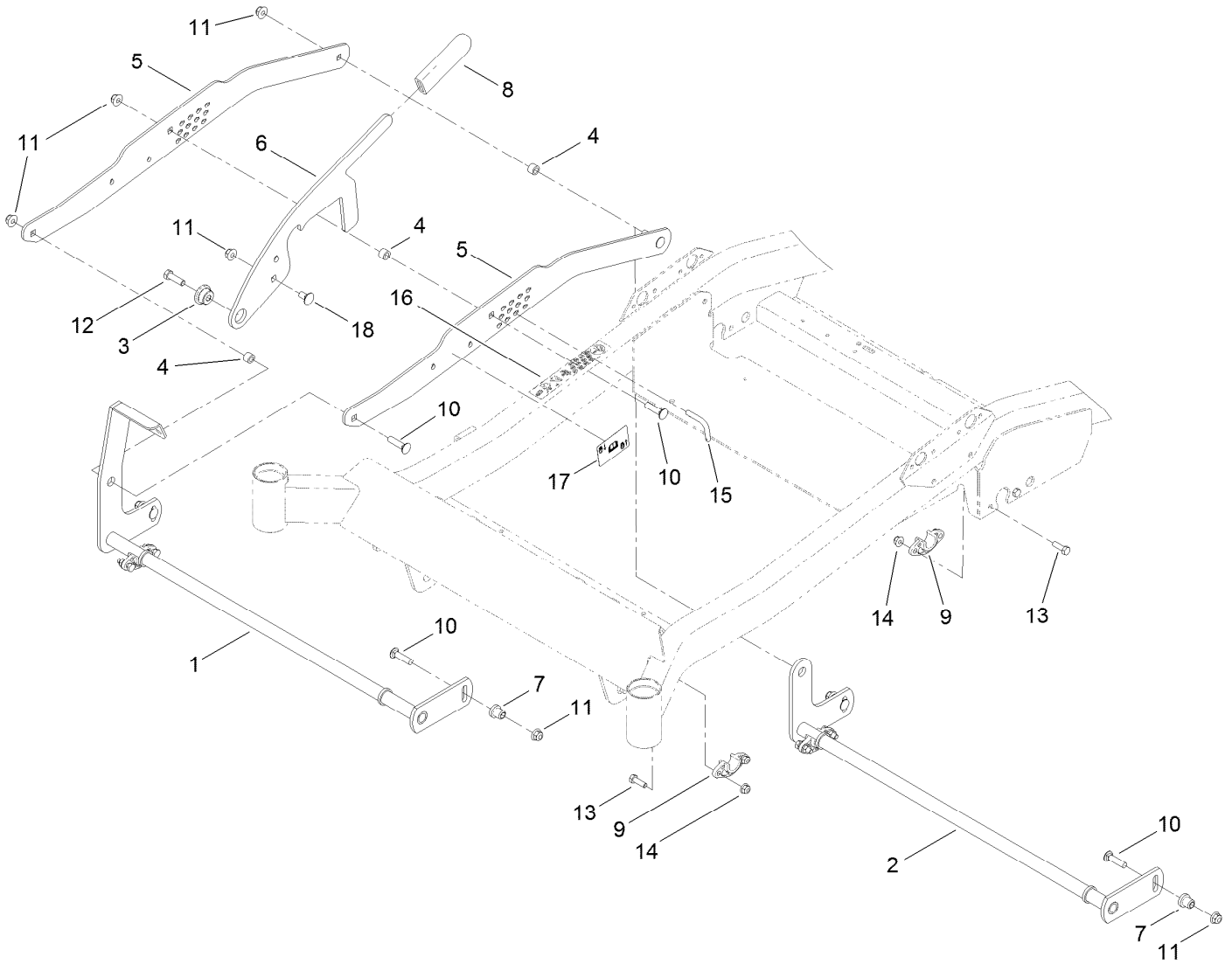

Deck Lift Assembly

Ref.	Part Number	Qty.	Description	Ref.	Part Number	Qty.	Description
1	115-2495-03	1	Pivot-Front	10	3231-4	7	Screw-CARR
2	115-2498-03	1	Pivot-Rear	11	104-8301	8	Nut-Flange, NI
3	117-1281	1	Bushing-Mount, HOC	12	323-7	1	Screw-HH
4	115-4986	3	Spacer	13	322-5	8	Screw-HH
5	115-2503-03	2	Plate-Lift, Foot	14	104-8300	8	Nut-Flange, NI
6	115-2504	1	Plate-Stop, HOC	15	117-1280	1	Pin-Keyed
7	65-5950	4	Bushing-Pulley	16	115-9644	1	Decal-HOC
8	1-633268	1	Grip-Lever	17	117-5344	1	Decal-Lock, Deck
9	115-5065	4	Bushing-Flange	18	3231-1	1	Screw-CARR

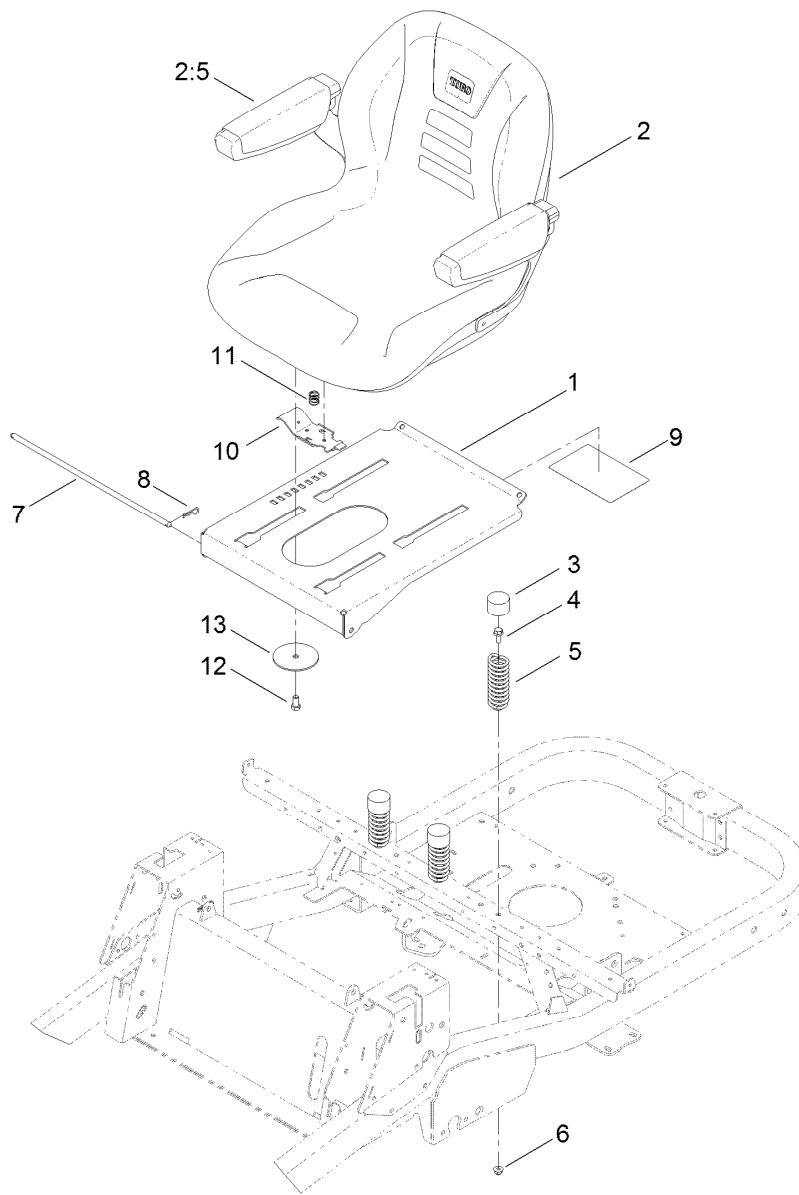

Seat Assembly

Ref.	Part Number	Qty.	Description
1	117-5320-03	1	Pan-Seat
2	115-5053	1	18 Inch Seat ASM
2:5	119-3307	1	Armrest Kit
3	701178	3	Cap-Protector
4	3234-47	3	Screw-HHF
5	92-7054	3	Spring-Compression
6	104-8300	3	Nut-Flange, NI
7	115-4966	1	Rod-Stop
8	3290-250	2	Pin-Hair
9	115-9630	1	Decal-Maintenance
10	115-9623	1	Latch-Seat
11	115-9624	1	Spring-Compression
12	323-4	1	Screw-HH
13	117-5307	1	Washer-Seat

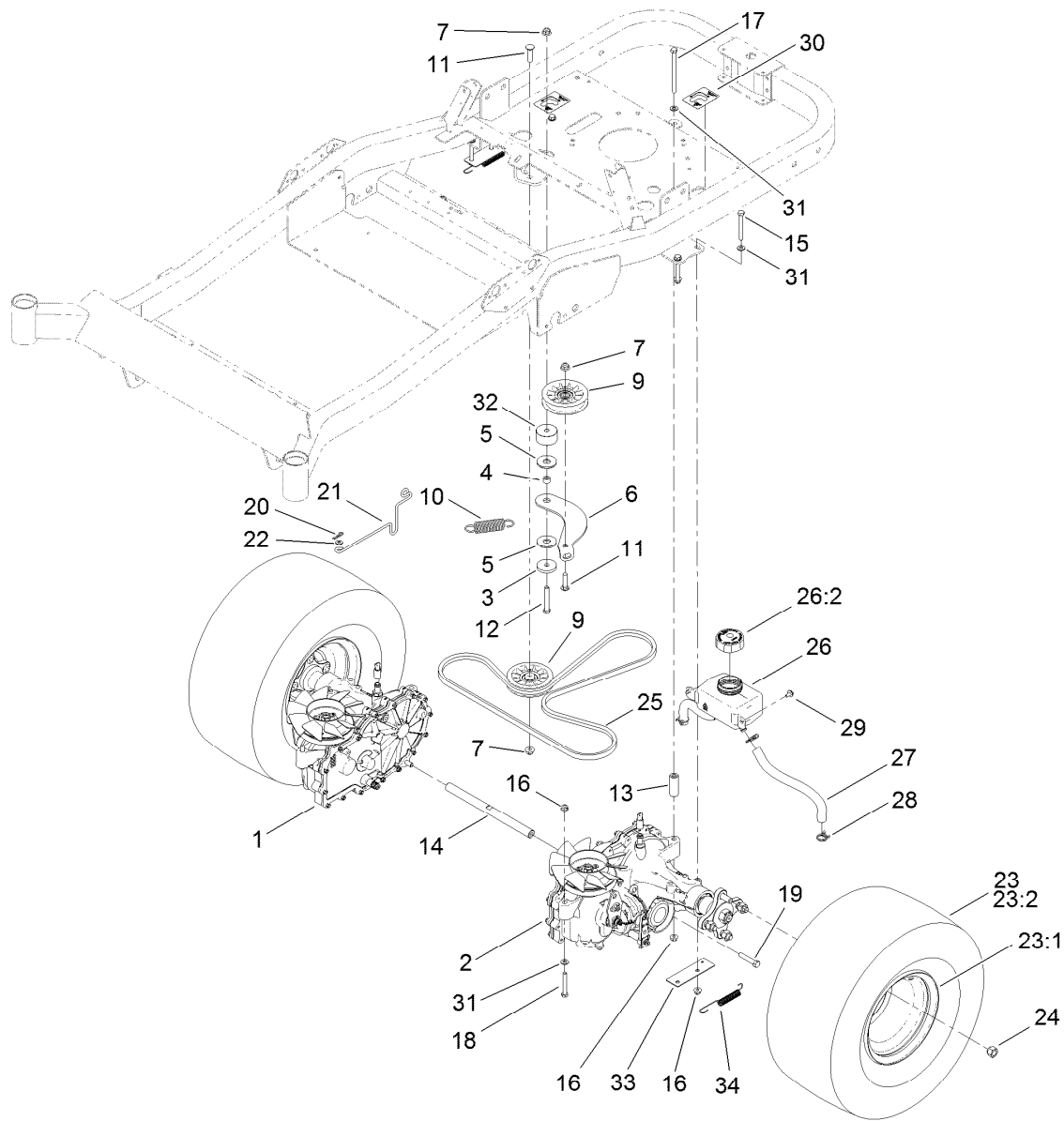

Traction Drive Assembly

Ref.	Part Number	Qty.	Description	Ref.	Part Number	Qty.	Description
1	115-2550	1	Hydro-RH	20	1-806003	2	Pin-Cotter, Hair
2	115-2551	1	Hydro-LH	21	115-4990	2	Rod-Bypass
3	110-9981	1	Washer-Plain	22	3256-22	2	Washer-Flat
4	115-4986	1	Spacer	23	109-5486	2	Wheel And Tire ASM
5	114-0463	2	Washer-Friction, Composite	23:1	109-5487	1	Wheel
6	117-5350	1	Arm-Idler	23:2	109-5488	1	Tire
7	104-8301	3	Nut-Flange, NI	24	242-50	8	Nut-Lug
9	109-3397	2	Pulley-Idler, Flat	25	115-9613	1	V-Belt
10	1-603402	1	Spring-Extension	26	115-9618	1	HYD Reservoir ASM
11	3231-4	2	Screw-CARR	26:2	109-3320	1	Cap-Reservoir, HYD
12	323-12	1	Screw-HH	27	115-4969	2	Hose-Overflow
13	109-3652	2	Spacer-Hydro	28	117-1193	4	Clamp-Hose
14	115-2559	1	Shaft-Cross, Hydro	29	46-8560	2	Screw-HHFTF
15	322-13	4	Screw-HH	30	117-1158	2	Decal-Bypass
16	104-8300	8	Nut-Flange, NI	31	3256-23	8	Washer-Flat
17	322-38	2	Screw-HH	32	117-5351	1	Spacer
18	322-11	2	Screw-HH	33	117-7248-03	2	Plate-Spring
19	323-10	2	Screw-HH	34	110769	2	Spring-Extension

RH Hydro Assembly No. 115-2550

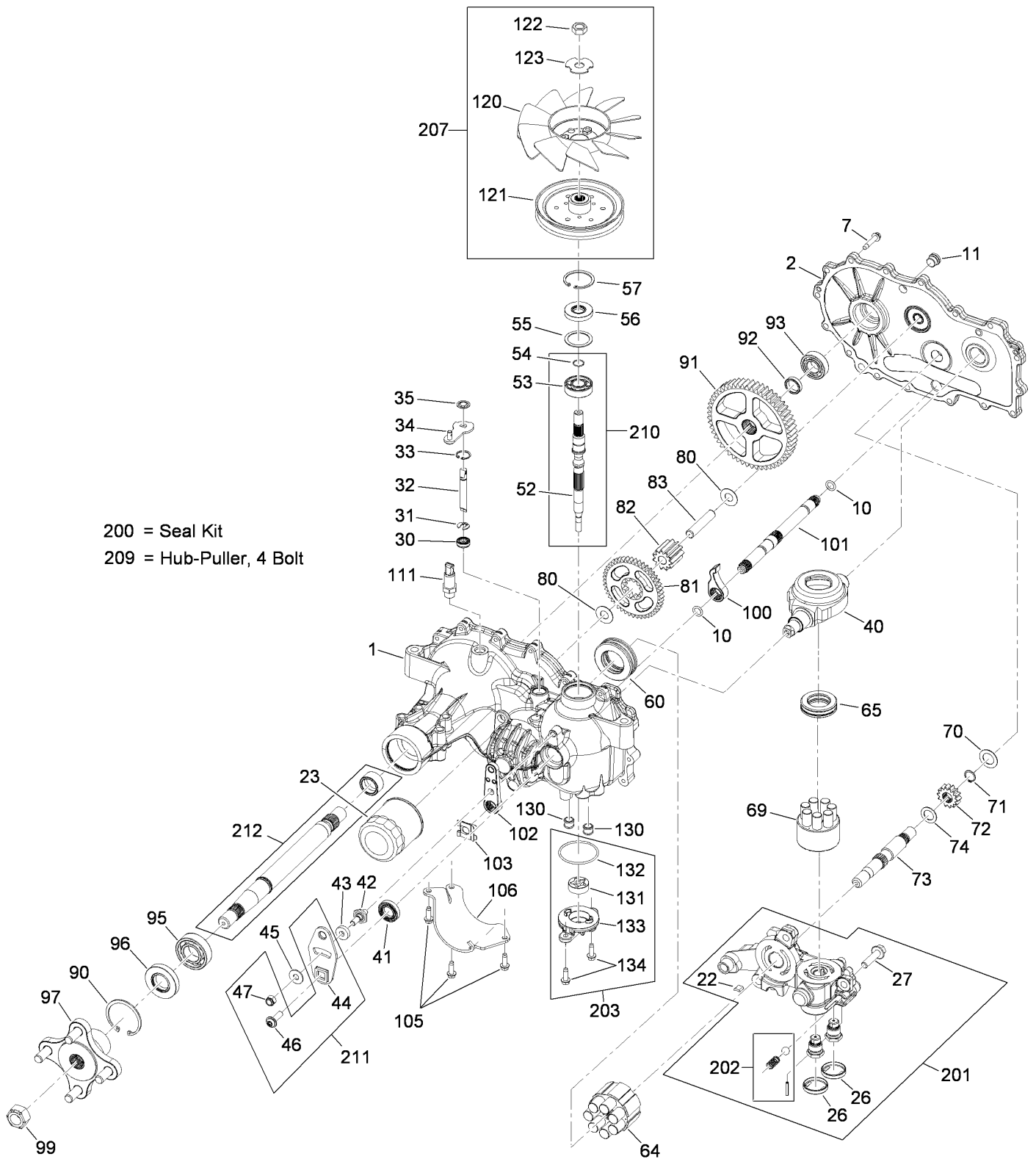

RH Hydro Assembly No. 115-2550 (continued)

<i>Ref.</i>	<i>Part Number</i>	<i>Qty.</i>	<i>Description</i>	<i>Ref.</i>	<i>Part Number</i>	<i>Qty.</i>	<i>Description</i>
1	117-5357	1	RH Main Housing Kit	80	94-1933	1	Washer
2	117-5358	1	RH Housing Side Kit	81	114-1692	1	Gear-45T
7	117-5359	16	Screw-Hfhcs	82	114-1693	1	Gear-11T
10	114-1678	2	O-Ring	83	104-5329	1	Pin-Jackshaft
11	104-2189	1	Plug-Thread, Straight	90	104-2169	1	Ring-Retaining
22	114-1680	1	Plate-Bypass	91	114-1694	1	Gear-54T
23	109-3321	1	Element-Oil Filter, HYD	92	114-1695	1	Spacer
26	114-1683	2	Seal-Plug	93	114-1696	1	Bearing-Ball
27	114-1684	3	Screw-Hfhc	95	104-2143	1	Bearing-Ball
30	106-8676	1	Seal-Lip	96	104-2144	1	Seal
31	106-8677	1	Ring-Retaining, EXT	97	109-5939	1	Hub Kit
32	114-1685	1	Rod-Bypass	99	105-1895	1	Nut
33	106-8679	1	Ring-Retaining, Int	100	114-1697	1	Pawl-Brake
34	107-2490	1	Arm-Bypass	101	117-5360	1	Shaft-Brake
35	106-8681	1	Ring-Retaining, EXT	102	114-1699	1	Handle-Brake
40	104-5304	1	Swashplate-Trunnion	103	114-8450	1	Clip-Retaining
41	104-5313	1	Seal-Lip	105	104-2120	3	Screw
42	104-2116	1	Stud	106	114-8473	1	Guard-Filter, LH
43	112-9853	1	Puck-Friction	111	109-3278	1	Adapter-Straight
44	106-8747	1	Arm-Control	120	114-8453	1	Fan-7.0
45	114-8491	1	Washer	121	114-8454	1	Pulley-5.0 Inch
46	107-2488	1	Screw	122	104-2168	1	Nut-Hex
47	105-1872	1	Nut	123	107-9122	1	Washer-Slotted
52	114-1687	1	Shaft-Input	130	114-8455	2	Tube-Connecting
53	104-5311	1	Bearing-Ball	131	104-2122	1	Gerotor ASM
54	104-5307	1	Ring-Retaining	132	109-3540	1	O-Ring-Seal
55	104-5308	1	Spacer	133	114-8457	1	Cover-Charge Pump
56	104-5310	1	Seal-Lip	134	104-2120	2	Screw
57	104-5309	1	Ring-Retaining	200	109-3537	1	Complete Seal Kit
60	112-4154	1	Bearing-Thrust	201	114-8463	1	RH Center Section Kit
64	114-1689	1	Motor Cylinder Block Kit	202	114-8464	1	Charge Relief Kit
65	94-6922	1	Bearing-Thrust	203	114-8465	1	Charge Kit
69	110-8561	1	Pump Block ASM	207	109-5938	1	Fan And Pulley Kit
70	104-5339	1	Washer-Flat	209	114-8467	1	Hub-Puller, 4 Bolt
71	104-5340	1	Ring-Retaining	210	117-5361	1	Shaft Input Kit
72	114-1690	1	Gear-14T	211	117-5362	1	Arm Control Kit
73	114-1691	1	Shaft-Motor	212	114-8470	1	Axle Shaft Kit
74	104-5360	1	Washer-Shaft, Motor				

LH Hydro Assembly No. 115-2551

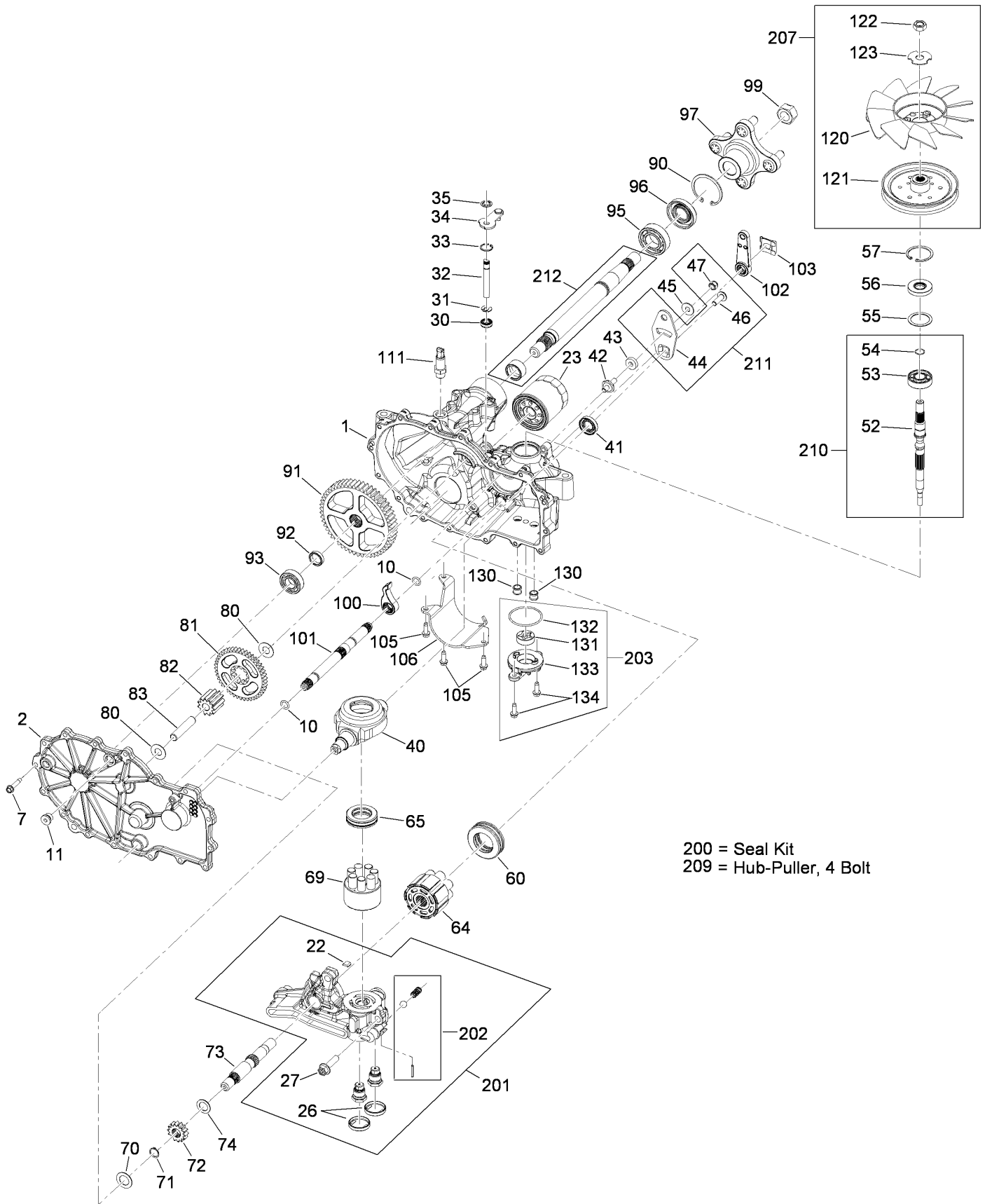

LH Hydro Assembly No. 115-2551 (continued)

<i>Ref.</i>	<i>Part Number</i>	<i>Qty.</i>	<i>Description</i>	<i>Ref.</i>	<i>Part Number</i>	<i>Qty.</i>	<i>Description</i>
1	114-8471	1	LH Main Housing Kit	80	94-1933	2	Washer
2	114-8472	1	LH Side Cover Kit	81	114-1692	1	Gear-45T
7	117-5359	16	Screw-Hfhcs	82	114-1693	1	Gear-11T
10	114-1678	2	O-Ring	83	104-5329	1	Pin-Jackshaft
11	104-2189	1	Plug-Thread, Straight	90	104-2169	1	Ring-Retaining
22	114-1680	1	Plate-Bypass	91	114-1694	1	Gear-54T
23	109-3321	1	Element-Oil Filter, HYD	92	114-1695	1	Spacer
26	114-1683	2	Seal-Plug	93	114-1696	1	Bearing-Ball
27	114-1684	3	Screw-Hfhc	95	104-2143	1	Bearing-Ball
30	106-8676	1	Seal-Lip	96	104-2144	1	Seal
31	106-8677	1	Ring-Retaining, EXT	97	109-5939	1	Hub Kit
32	114-1685	1	Rod-Bypass	99	109-3536	1	Nut-Hub
33	106-8679	1	Ring-Retaining, Int	100	114-1697	1	Pawl-Brake
34	107-2490	1	Arm-Bypass	101	117-5360	1	Shaft-Brake
35	106-8681	1	Ring-Retaining, EXT	102	114-1699	1	Handle-Brake
40	104-5304	1	Swashplate-Trunnion	103	114-8450	1	Clip-Retaining
41	104-5313	1	Seal-Lip	105	104-2120	3	Screw
42	104-2116	1	Stud	106	114-8473	1	Guard-Filter, LH
43	112-9853	1	Puck-Friction	111	109-3278	1	Adapter-Straight
44	106-8747	1	Arm-Control	120	114-8453	1	Fan-7.0
45	114-8491	1	Washer	121	114-8454	1	Pulley-5.0 Inch
46	107-2488	1	Screw	122	104-2168	1	Nut-Hex
47	105-1872	1	Nut	123	107-9122	1	Washer-Slotted
52	114-1687	1	Shaft-Input	130	114-8455	2	Tube-Connecting
53	104-5311	1	Bearing-Ball	131	104-2122	1	Gerotor ASM
54	104-5307	1	Ring-Retaining	132	109-3540	1	O-Ring-Seal
55	104-5308	1	Spacer	133	114-8457	1	Cover-Charge Pump
56	104-5310	1	Seal-Lip	134	104-2120	2	Screw
57	104-5309	1	Ring-Retaining	200	109-3537	1	Complete Seal Kit
60	114-1688	1	Bearing-Thrust	201	114-8476	1	LH Center Section Kit
64	114-1689	1	Motor Cylinder Block Kit	202	114-8464	1	Charge Relief Kit
65	94-6922	1	Bearing-Thrust	203	114-8465	1	Charge Kit
69	110-8561	1	Pump Block ASM	207	109-5938	1	Fan And Pulley Kit
70	104-5339	1	Washer-Flat	209	114-8467	1	Hub-Puller, 4 Bolt
71	104-5340	1	Ring-Retaining	210	117-5361	1	Shaft Input Kit
72	114-1690	1	Gear-14T	211	117-5362	1	Arm Control Kit
73	114-1691	1	Shaft-Motor	212	114-8470	1	Axle Shaft Kit
74	104-5360	1	Washer-Shaft, Motor				

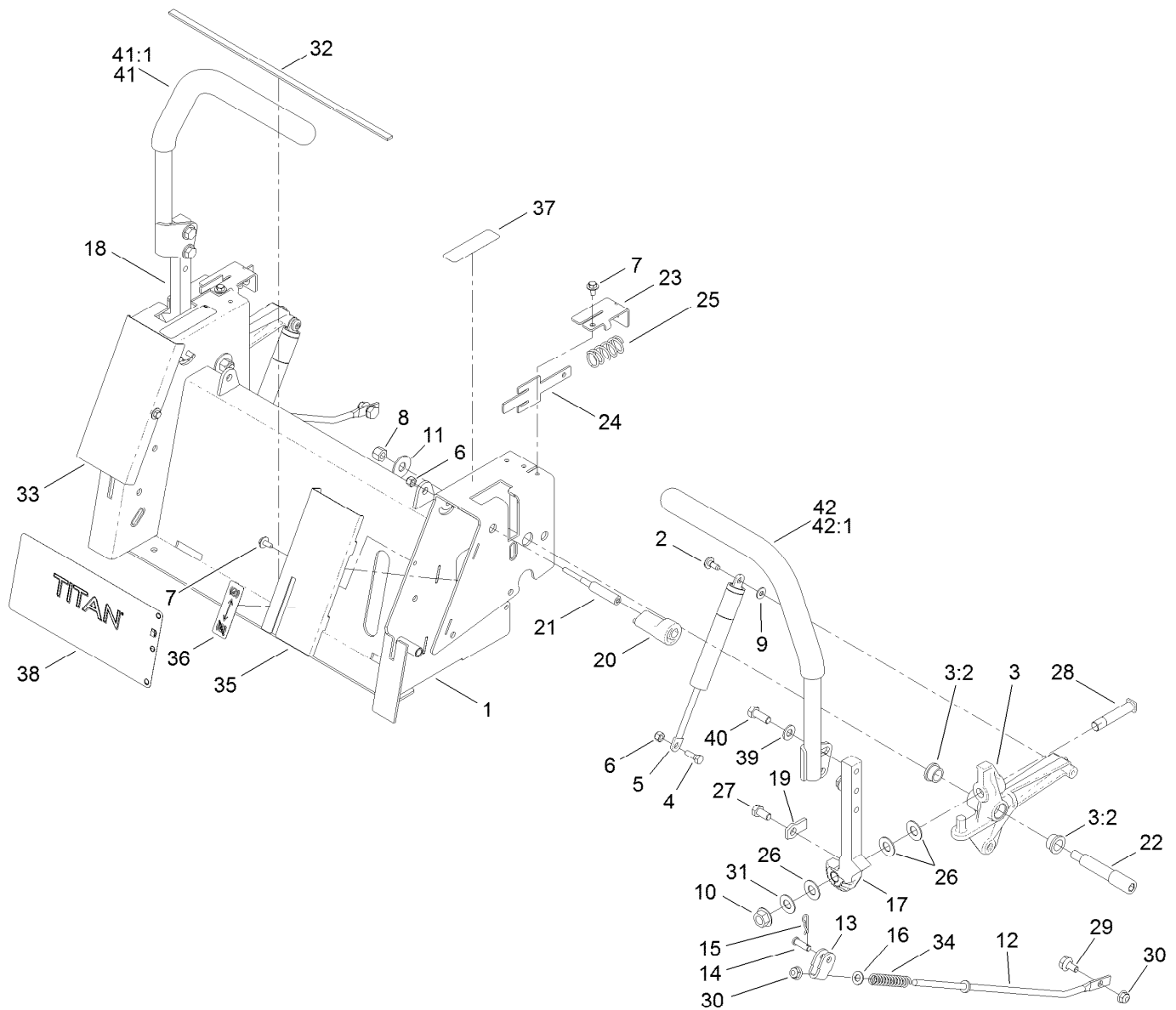

Motion Control Assembly

Ref.	Part Number	Qty.	Description	Ref.	Part Number	Qty.	Description
1	115-2546-03	1	Box-Control	21	110-6874	2	Screw-Eccentric
2	112-4004	2	Screw-Shoulder	22	110-6875	2	Bolt-Shoulder
3	110-6828	2	Activator Arm ASM	23	110-6751	2	Bracket-Return
3:2	105-3455	2	Bushing	24	110-6750	2	Plate-Return
4	106-2214	2	Bolt-Shoulder	25	110-6752	2	Spring-Compression
5	109-2339	2	Damper-Control, Motion	26	110-6894	6	Washer-Pivot
6	3296-42	4	Nut-Lock, NI	27	323-4	2	Screw-HH
7	46-8560	4	Screw-HHFTF	28	110-6784	2	Bolt-Shoulder
8	3296-48	2	Nut-Lock, NI	29	37-8771	2	Bolt-Shoulder
9	119-8952	2	Washer	30	104-8300	4	Nut-Flange, NI
10	32128-23	2	Nut-HF	31	112-9771	2	Washer-Teflon
11	3256-5	2	Washer-Flat	32	117-7237	1	Strip-Vibration, Anti
12	117-7422	2	Rod-Control	33	117-1255-03	1	Cover-Control, RH
13	117-7423	2	Bracket-Control	34	1-603807	2	Spring-Return, Neutral
14	1-808280	2	Pin-Clevis	35	115-2561-03	1	Cover-Control, LH
15	1-806003	2	Pin-Cotter, Hair	36	115-9625	1	Decal
16	3256-23	2	Washer-Flat	37	99-8936	2	Decal-Control, Motion
17	110-6783-05	1	Arm-Actuator, LH	38	119-8983	1	Decal
18	110-6782-05	1	Arm-Actuator, RH	39	3256-24	4	Washer-Flat
19	115-5023	2	Tab-Stop	40	323-6	4	Screw-HH
20	110-6873	2	Eccentric	41	119-3486	1	RH Handle ASM

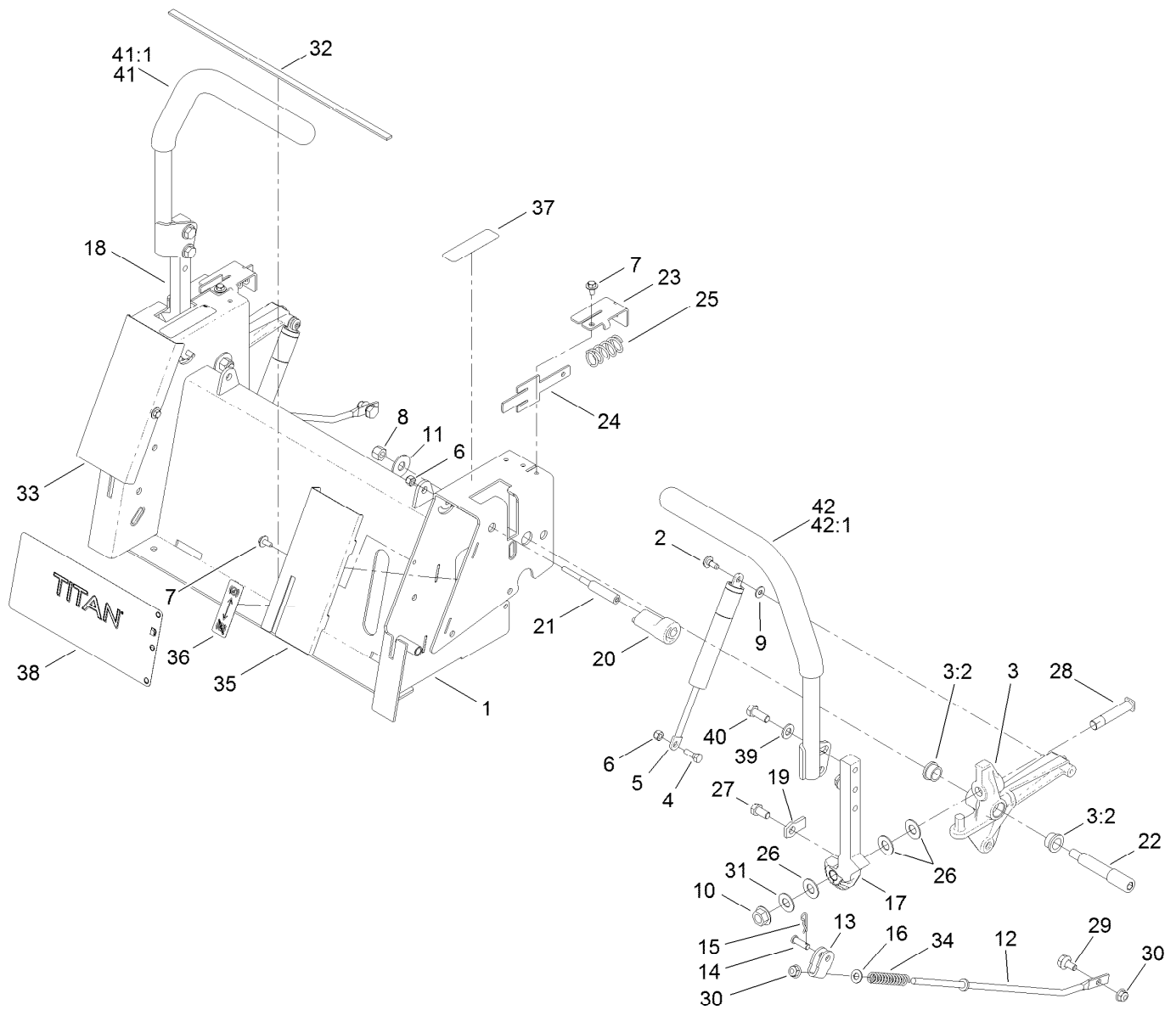

Motion Control Assembly (continued)

<i>Ref.</i>	<i>Part Number</i>	<i>Qty.</i>	<i>Description</i>
41:1	108-6187	1	Grip

<i>Ref.</i>	<i>Part Number</i>	<i>Qty.</i>	<i>Description</i>
42	119-3485	1	LH Handle ASM
42:1	108-6187	1	Grip

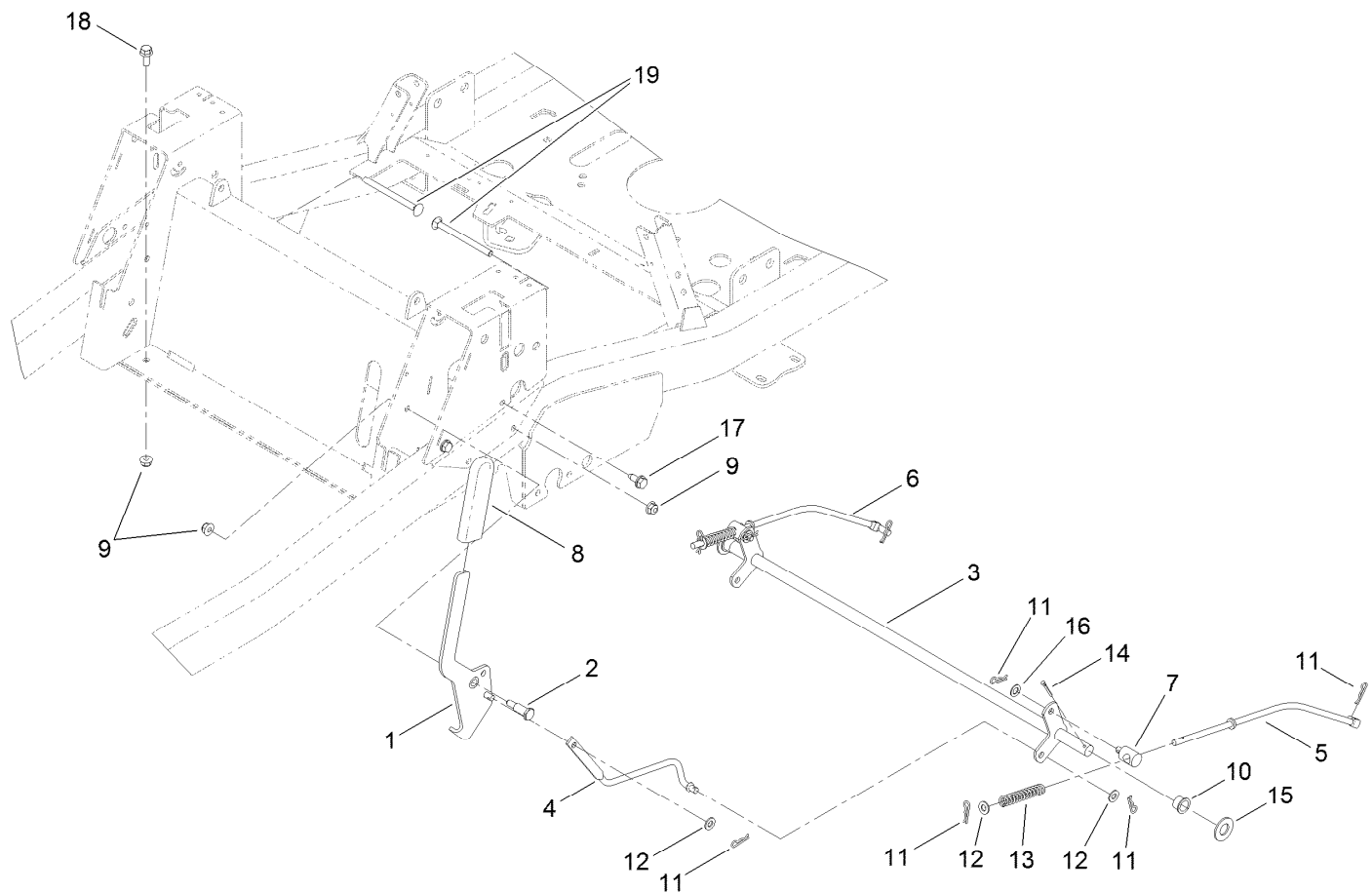

Brake Link Assembly

<i>Ref.</i>	<i>Part Number</i>	<i>Qty.</i>	<i>Description</i>	<i>Ref.</i>	<i>Part Number</i>	<i>Qty.</i>	<i>Description</i>
1	119-3460	1	Handle-Brake	11	1-806003	8	Pin-Cotter, Hair
2	63-2650	1	Screw-Shoulder	12	3256-23	4	Washer-Flat
3	115-5071-03	1	Brake-Bellcrank	13	1-603807	2	Spring-Return, Neutral
4	115-5074	1	Link-Brake	14	3272-11	2	Pin-Cotter
5	117-7322	1	Rod-Brake, LH	15	3256-27	2	Washer-Flat
6	117-7323	1	Rod-Brake, RH	16	40-1940	2	Washer
7	115-9681	2	Fitting-Rod	17	32144-70	4	Screw-HWHTF
8	1-633268	1	Grip-Lever	18	3234-47	2	Screw-HHF
9	104-8300	5	Nut-Flange, NI	19	106-9758	2	Screw-CARR
10	256-292	2	Bushing-Flange, NI				

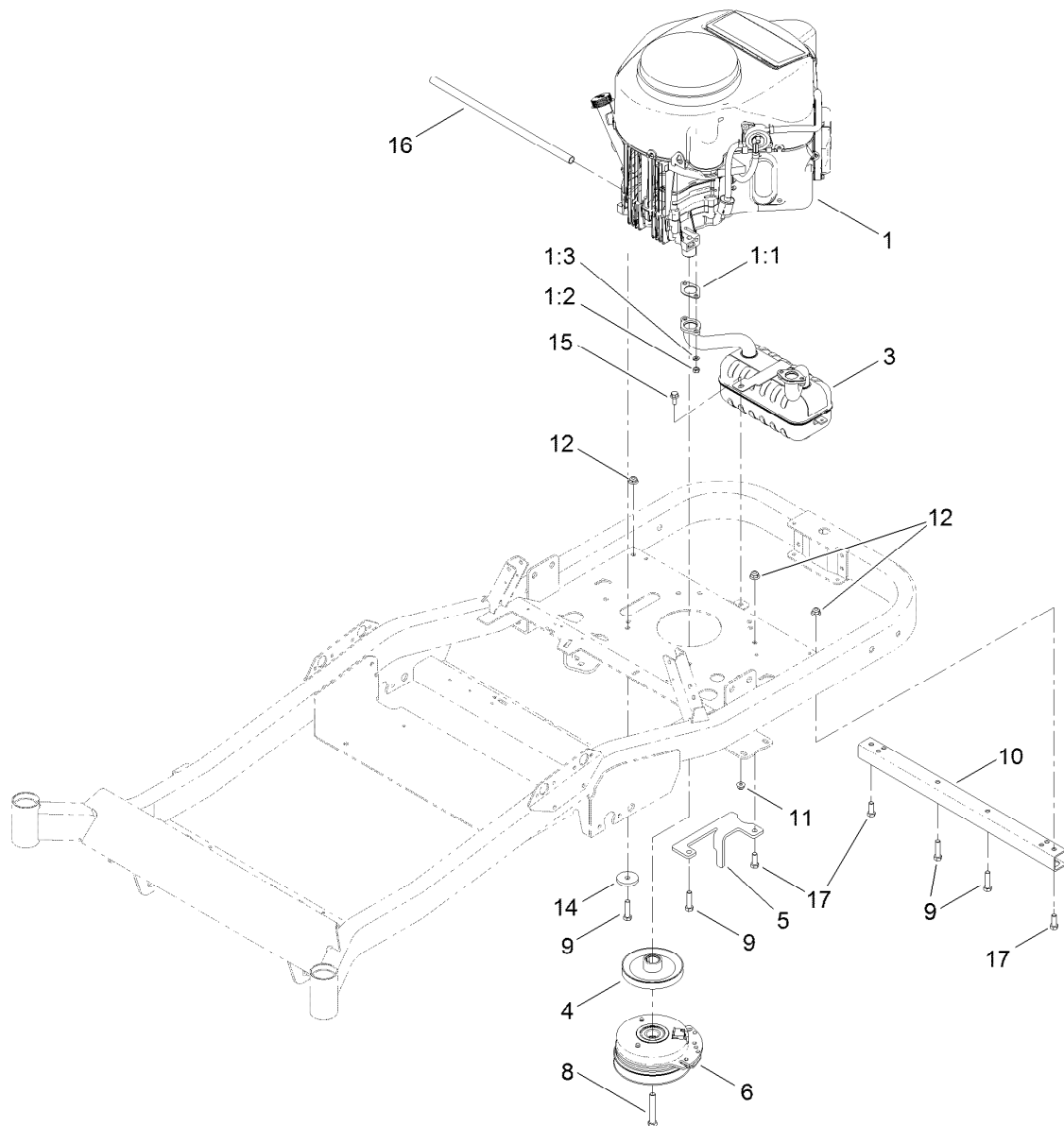

Engine, Muffler and Clutch Assembly

Ref.	Part Number	Qty.	Description
1		1	Engine-Kawasaki, Fr651V- s10-R ●■
1:1	1-653313	2	Gasket-Exhaust
1:2	114-3549	4	Nut
1:3	114-3550	4	Washer-Lock, Spring
3	117-7465	1	Muffler-Kawasaki Twin
4	115-2568	1	Pulley-Engine
5	117-7344-03	1	Bracket-Stop, PTO
6	117-1252	1	Clutch-PTO

Ref.	Part Number	Qty.	Description
8	3212-11	1	Screw-HH
9	323-50	4	Bolt-HH
10	117-7335-03	1	Tube-Stiffener
11	104-8300	1	Nut-Flange, NI
12	104-8301	3	Nut-Flange, NI
14	110-9981	1	Washer-Plain
15	3234-47	1	Screw-HHF
16	106-7022	1	Tube-Drain, Oil
17	323-6	3	Screw-HH

● Not serviced separately

■ Obtain parts from www.kawpowerepc.com

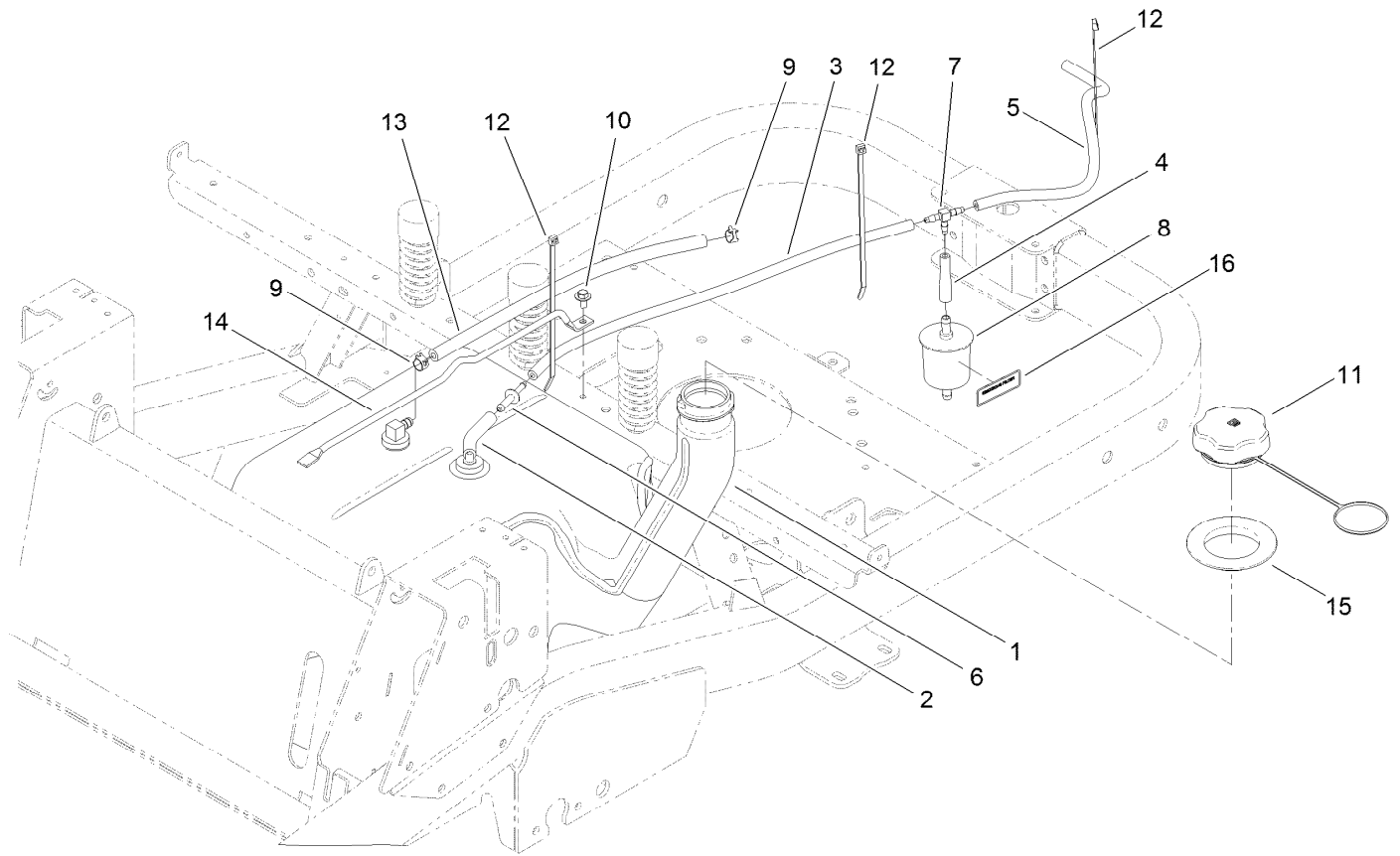

Fuel Delivery Assembly

<i>Ref.</i>	<i>Part Number</i>	<i>Qty.</i>	<i>Description</i>	<i>Ref.</i>	<i>Part Number</i>	<i>Qty.</i>	<i>Description</i>
1	117-7352	1	Multi Layer Fuel Tank ASM	9	2412-98	2	Clamp
2	114-3765	1	Hose-Fuel	10	46-8560	1	Screw-HHFTF
3	119-8150	1	Hose-Fuel	11	114-0294	1	Cap-Fuel, Ratcheting
4	120-2272	1	Hose-Fuel, Molded	12	614249	3	Strap-Tie
5	119-8150	1	Hose-Fuel	13	107-0589	1	Hose-Fuel
6	117-5399	1	Adaptor-Orifice	14	115-2620	1	Rod-Tank, Gas
7	120-2234	1	Fitting-Tee	15	117-1298	1	Seal-Tank
8	120-2235	1	Filter-Air	16	116-4769	1	Decal-Filter, Emissions

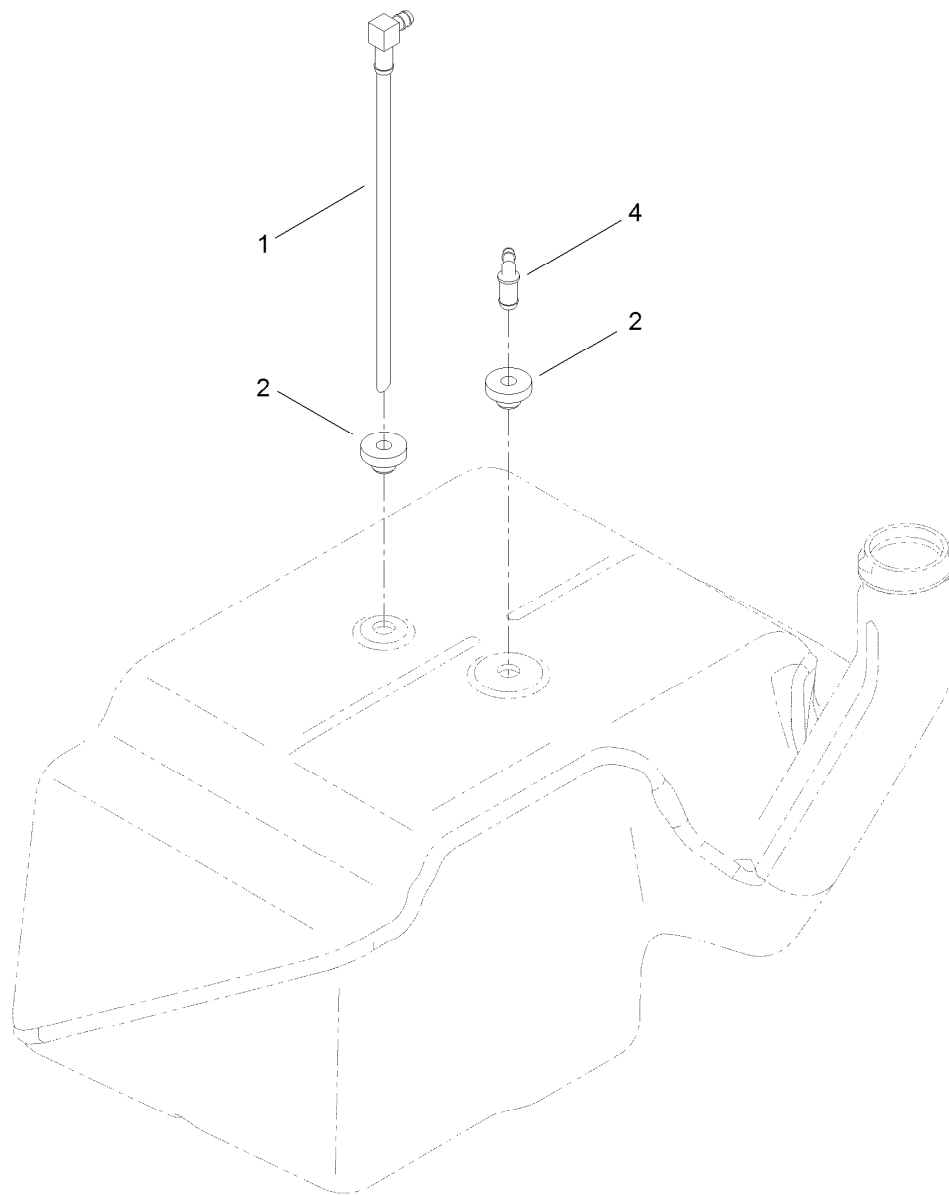

Multi Layer Fuel Tank Assembly No. 117-7352

<i>Ref.</i>	<i>Part Number</i>	<i>Qty.</i>	<i>Description</i>
1	115-2564	1	Tube-Drop
2	46-6560	2	Bushing
4	117-7400	1	Fitting-Plastic

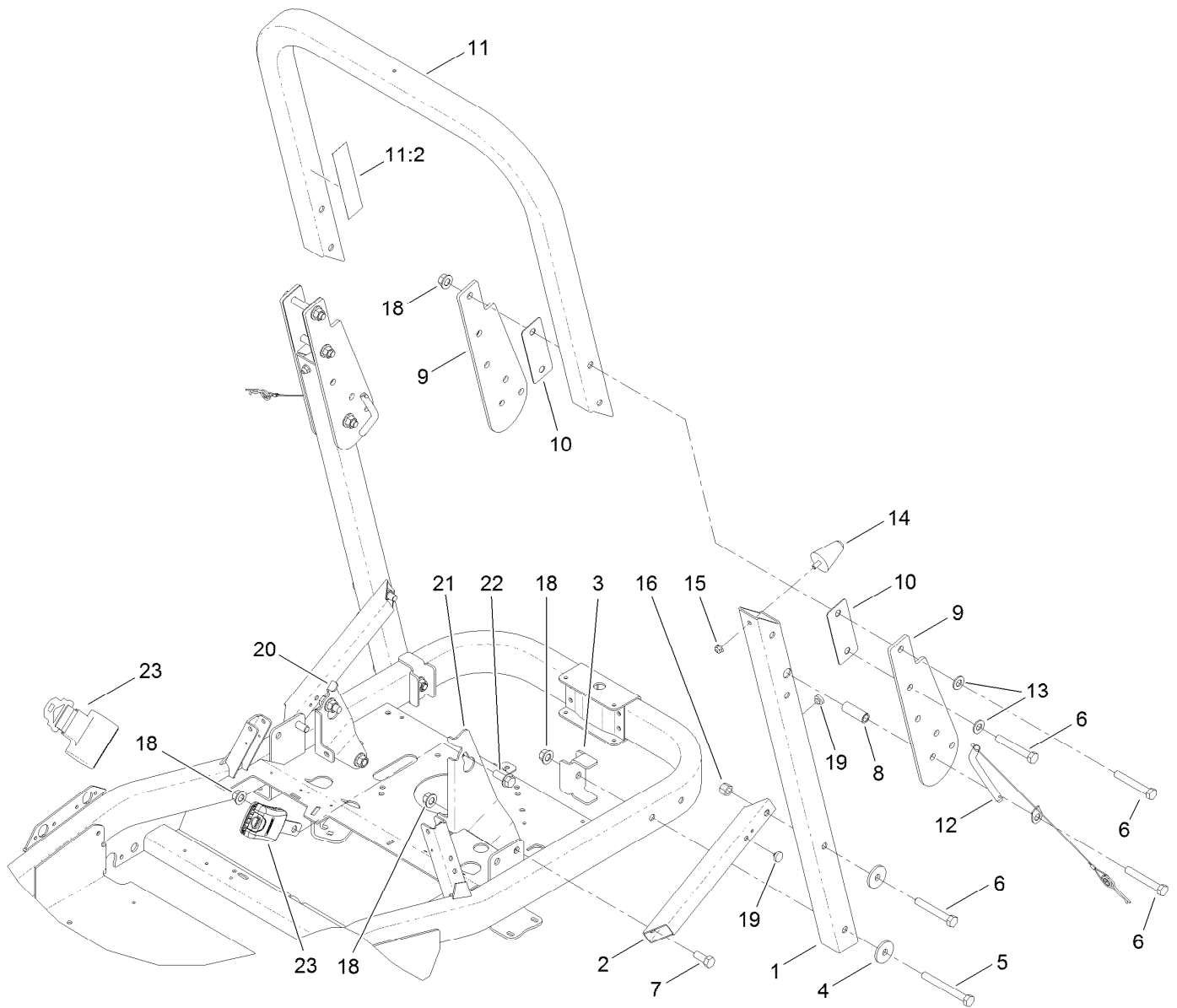

Roll-Over Protection System Assembly

Ref.	Part Number	Qty.	Description
1	119-8906-03	2	Tube-ROPS, Lower
2	115-4962-03	2	Tube-Support, ROPS
3	115-4963-03	2	Bracket-Reinforcing
4	84-1560	4	Washer-Thrust
5	325-18	2	Screw-HH
6	325-14	8	Screw-HH
7	325-5	2	Screw-HH
8	109-6653	2	Spacer
9	119-8911-03	4	Bracket-Pivot, ROPS
10	119-8926-03	4	Spacer-ROPS
11	119-8991	1	Upper ROPS ASM
11:2	107-3069	1	Decal-Warning, Folding ROPS

Ref.	Part Number	Qty.	Description
12	119-8970	2	Pin-ROPS
13	3256-26	4	Washer-Flat
14	114-1925	2	Bumper-Rubber
15	104-8300	2	Nut-Flange, NI
16	119-8969	2	Nut-Hex
18	99-5107	10	Nut-Lock
19	1-513658	4	Bumper
20	115-5038-03	1	Bracket-Seat Belt
21	115-5060-03	1	Bracket-Seat Belt
22	3234-38	2	Screw-HHF
23	109-9805	1	Seat Belt Kit

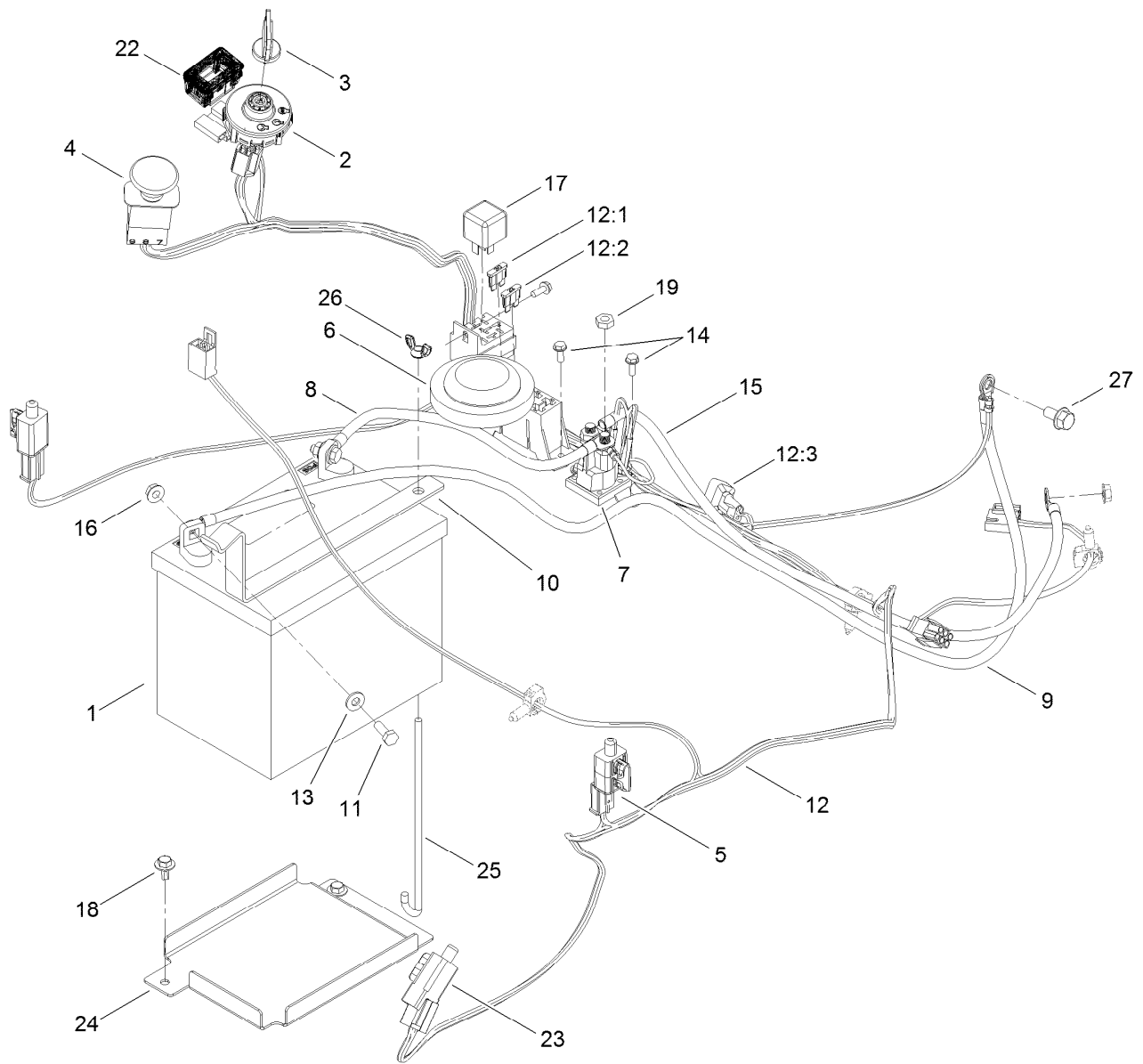

Electrical Assembly

<i>Ref.</i>	<i>Part Number</i>	<i>Qty.</i>	<i>Description</i>	<i>Ref.</i>	<i>Part Number</i>	<i>Qty.</i>	<i>Description</i>
1	104-2493	1	Battery	12:3	100-4918	1	Diode
2	117-2221	1	Switch-Ignition	13	3256-22	2	Washer-Flat
3	63-8360	1	Key-Ignition	14	32144-1	5	Screw-Taptite
4	93-9998	1	Switch-PTO	15	92-6989	1	Wire-21 Inch
5	110-6765	2	Switch-Single Pole No	16	32128-33	3	Nut-HF
6	100-3524	1	Switch-Seat	17	98-7249	1	Relay
7	117-1197	1	Solenoid	18	46-8560	2	Screw-HHFTF
8	117-5342	1	Cable-Battery, Positive	19	3220-2	2	Nut-Jam
9	117-7240	1	Cable-Battery, Negative	22	120-2244	1	Hourmeter
10	117-7313-01	1	Strap-Battery	23	99-7408	1	Switch-Reverse
11	321-4	2	Screw-HH	24	117-1283-03	1	Tray-Battery
12	117-7243	1	Harness-Wire	25	1-633651	1	Bolt-Holddown
12:1	109103	1	Fuse-Blade, 30 Amp	26	1-543792	1	Wingnut
12:2	109102	1	Fuse-Blade, 25 Amp	27	33104-016	1	Screw-HHF

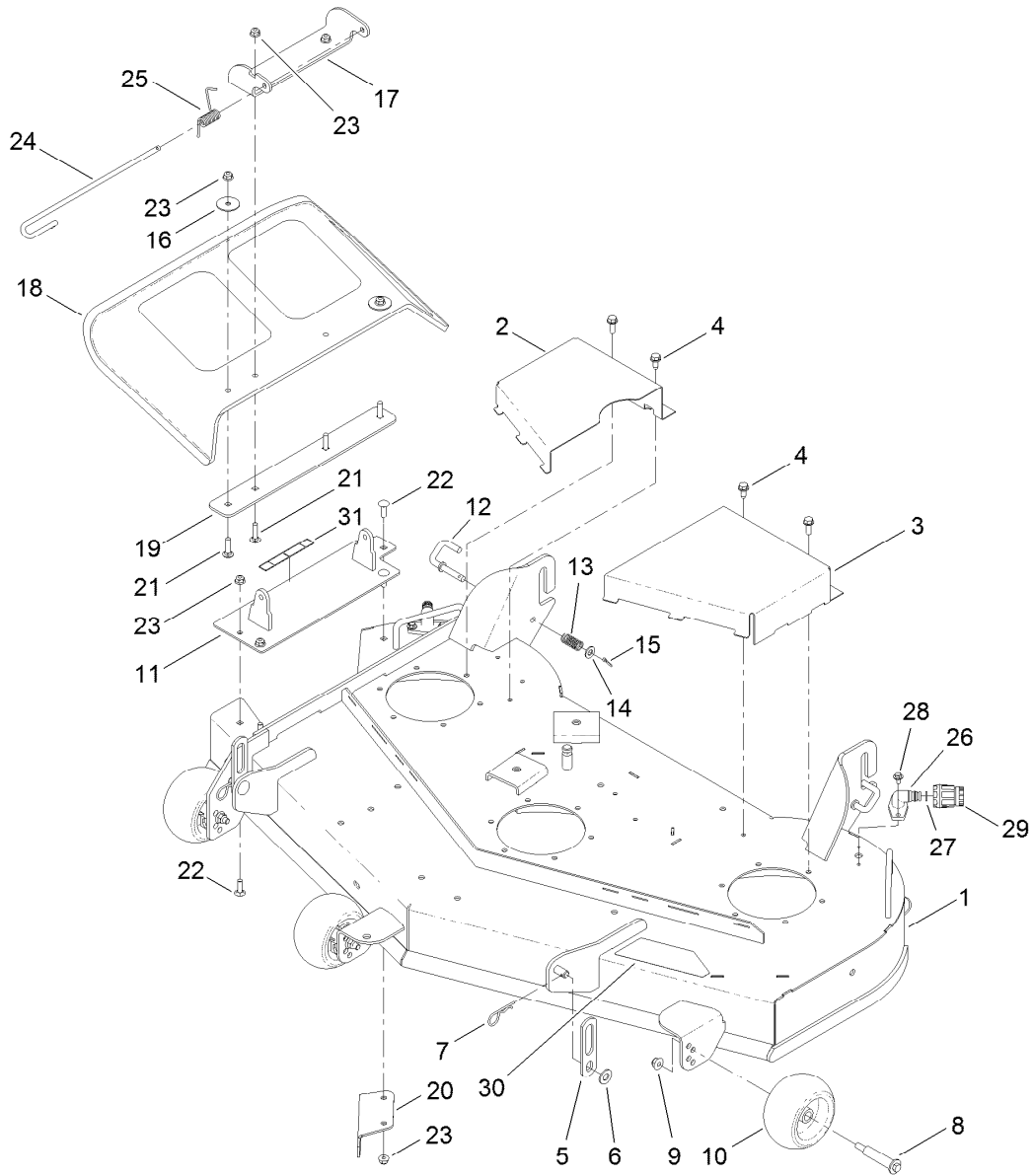

48 Inch Deck Assembly

Ref.	Part Number	Qty.	Description	Ref.	Part Number	Qty.	Description
1	119-3383	1	48 Inch Deck And Decal ASM	16	3256-68	2	Washer-Flat
2	117-7396-03	1	Cover-Belt, RH	17	114-1648-03	1	Bracket-Deflector, Upper
3	117-7397-03	1	Cover-Belt, LH	18	117-1270	1	Deflector-Molded
4	32144-70	2	Screw-HWHTF	19	115-5048-03	1	Plate-Deflector
5	115-2622	2	Link-Lift	20	117-7418-03	1	Baffle-Cutoff
6	3256-26	2	Washer-Flat	21	3230-3	4	Screw-CARR
7	1-806005	2	Pin-Hair	22	3230-22	4	Screw-CARR
8	112-3977	3	Bolt-Shoulder	23	104-8300	8	Nut-Flange, NI
9	104-8301	3	Nut-Flange, NI	24	109-8854	1	Pin-Chute
10	1-603299	3	Roller-Scalp, Anti	25	115-9641	1	Spring-Torsion
11	117-7367-03	1	Plate ASM	26	95-2747	2	Fitting-Washout
12	115-2470	2	Pin-Latch	27	46-6290	2	O-Ring, Seal
13	101853	2	Spring-Compression	28	46-8560	4	Screw-HHFTF
14	3256-24	2	Washer-Flat	29	95-3270	1	Connector-Hose
15	3272-10	2	Pin-Cotter	30	119-3382	1	Decal-Deck
				31	93-7009	1	Decal-Danger, Deflector

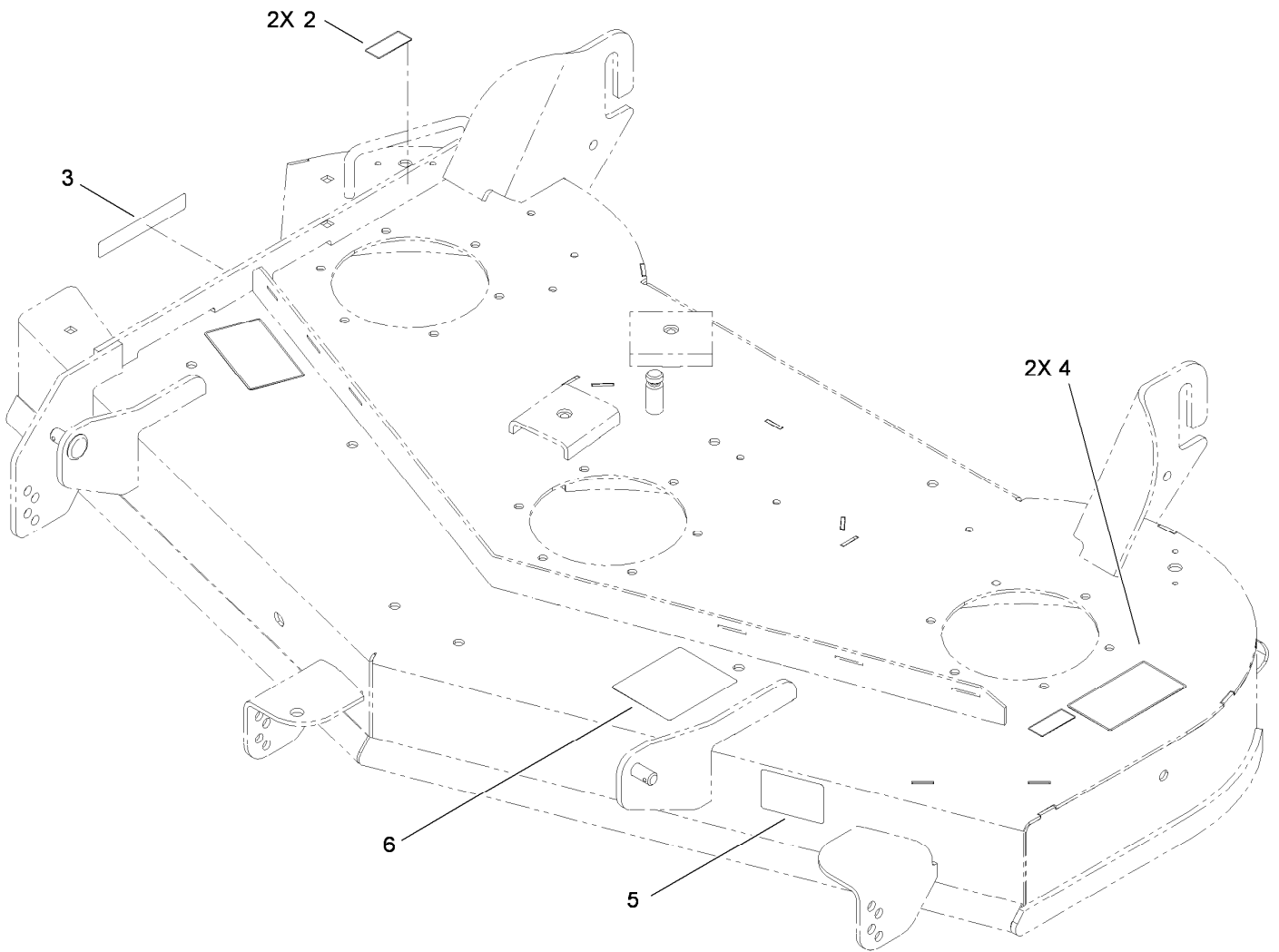

48 Inch Deck Decal Assembly No. 119-3383

<i>Ref.</i>	<i>Part Number</i>	<i>Qty.</i>	<i>Description</i>
2	114-1606	2	Decal-Danger, Pulley
3	93-7009	1	Decal-Danger, Deflector
4	110-6691	2	Decal-Danger
5	112-9840	1	Decal-Scalp, Anti
6	117-1194	1	Decal-Routing, Belt

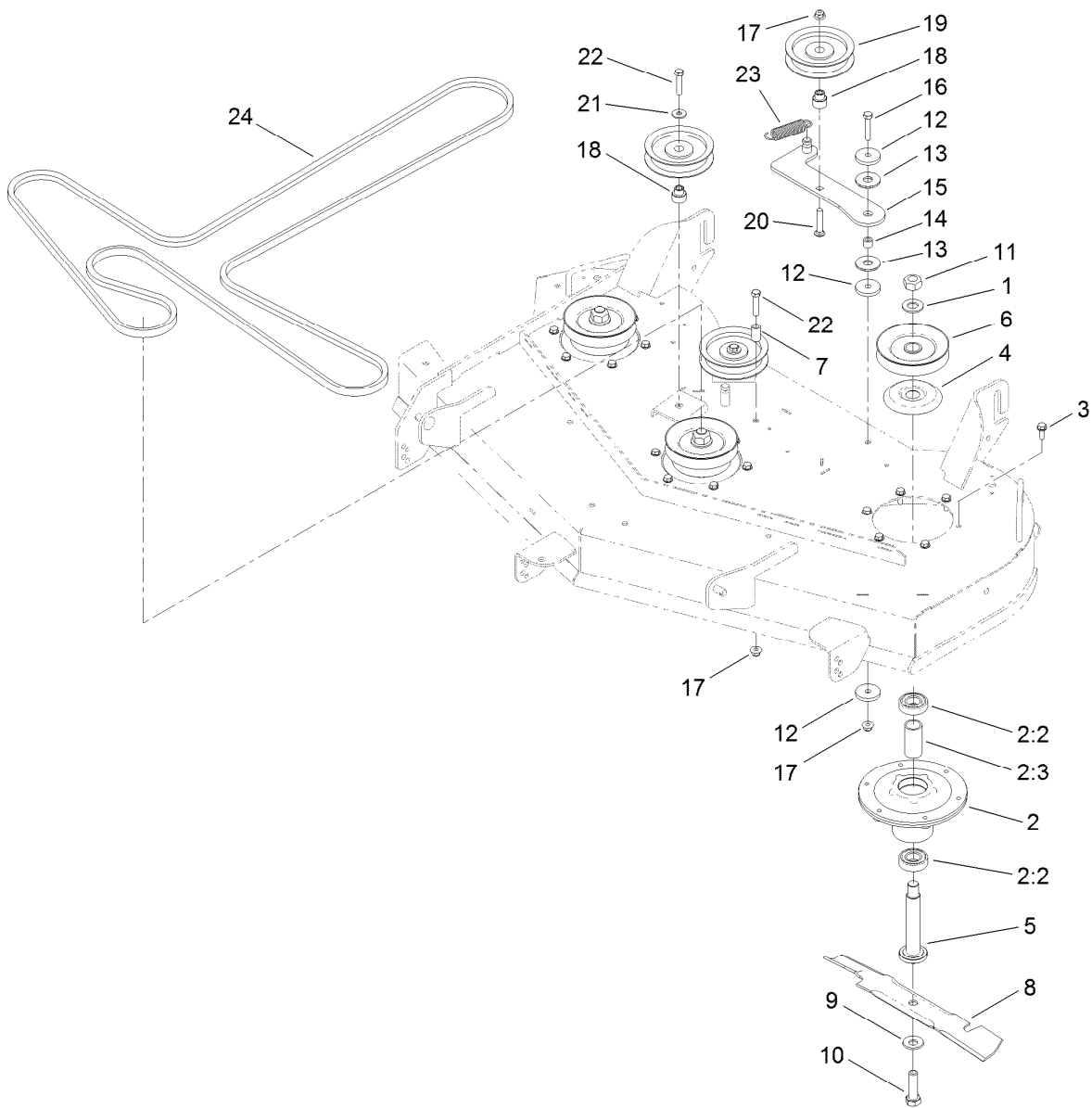

48 Inch Deck Belt, Spindle and Hi-Flo Blade Assembly

Ref.	Part Number	Qty.	Description
1	7-4150	3	Washer
2	120-5477	3	Spindle ASM
2:2	116-0720	2	Bearing-Ball, 25Mm
2:3	115-2641	1	Spacer-Bearing
3	32144-41	18	Screw-Taptite
4	117-7210	3	Shield-Bearing
5	115-2642	3	Shaft-Spindle
6	117-7326	3	Pulley
7	1-603401	1	Spacer-Fender
8	117-7277-03	3	Blade-Hi Flo, 16.50 Inch
9	22-8520	3	Washer-Belleville
10	51-4060	3	Screw-Blade
11	3219-7	3	Nut-Hex

Ref.	Part Number	Qty.	Description
12	110-9981	3	Washer-Plain
13	114-0463	2	Washer-Friction, Composite
14	1-413088	1	Bushing-Lever, Lift
15	115-5054	1	Idler Arm ASM
16	323-10	1	Screw-HH
17	104-8301	3	Nut-Flange, NI
18	115-2577	3	Bushing-Idler
19	1-603843	3	Pulley-Idler
20	3231-6	1	Screw-CARR
21	80-6990	2	Washer-Hardened
22	323-9	3	Screw-HH
23	108-4056	1	Spring-Extension
24	117-7325	1	V-Belt

Attachments and Accessories

For 74841 TITAN ZX4820 Zero-Turn-Radius Riding Mower

Product Name	Model/Part
Hitch Kit	117-5315
Step Kit	117-5316
Light Kit.....	117-5317
Transport Seat Hold Down Kit.....	117-7251
48in Bagger Finishing Kit.....	119-3319
48in Recycler Kit.....	119-3320
48in Striping Kit.....	119-3380
Leaf Bagging Enhancement Kit	119-3381
Bagger	79326
10 cu. ft. Poly Dump Cart	79991

Notes:

Notes:



Count on it.