



Electric Bed Lift Kit

for 2011 and After Workman® MDE Utility Vehicle

Model No. 07382—Serial No. 311000001 and Up

Installation Instructions

Installation

Loose Parts

Use the chart below to verify that all parts have been shipped.

Procedure	Description	Qty.	Use
1	No parts required	–	Prepare the Machine
2	Lift bracket, upper Pan-head, Phillips screw (3/8 x 2-1/2 inches) Flange locknut (Whiz lock) (3/8 inch) Lift cylinder support Lift actuator U-bolts Flange locknut (Nylock) (3/8 inch) Carriage bolts (3/8 x 3/4 inch) Clevis pin Cotter pin	1 4 4 1 1 2 6 2 1 1	Install the bed lift
3	Solenoid Bolt (#10 x 3/4 inch) Nut (#10) Accessory harness Switch Clevis pin, large Cotter pin	1 2 2 1 1 1 1	Install the switch

Note: Determine the left and right sides of the machine from the normal operating position.



Preparing the Machine

No Parts Required

Procedure

1. Position the machine on a level surface. Set the parking brake, turn the ignition off, and remove the key.

▲ WARNING

If you leave the key in the ignition switch, someone could accidentally start the machine and seriously injure you or other bystanders.

Remove the key from the ignition switch before you do any maintenance.

2. Lift the lever on either side of the box and lift the box up (Figure 1).

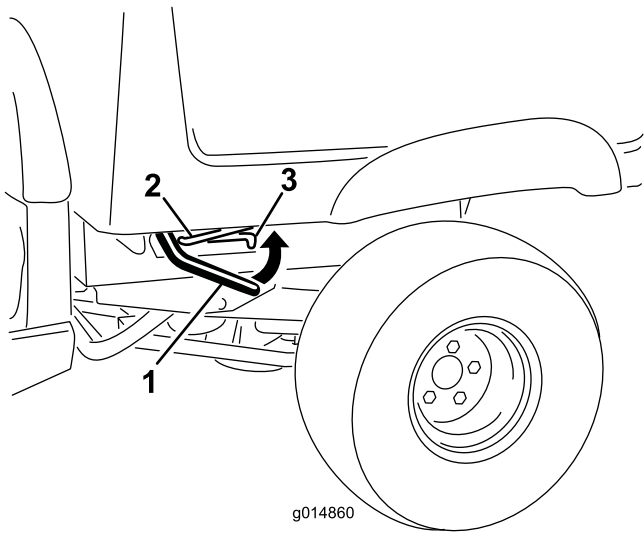

Figure 1

- 1. Lever
- 2. Prop rod
- 3. Detent slot

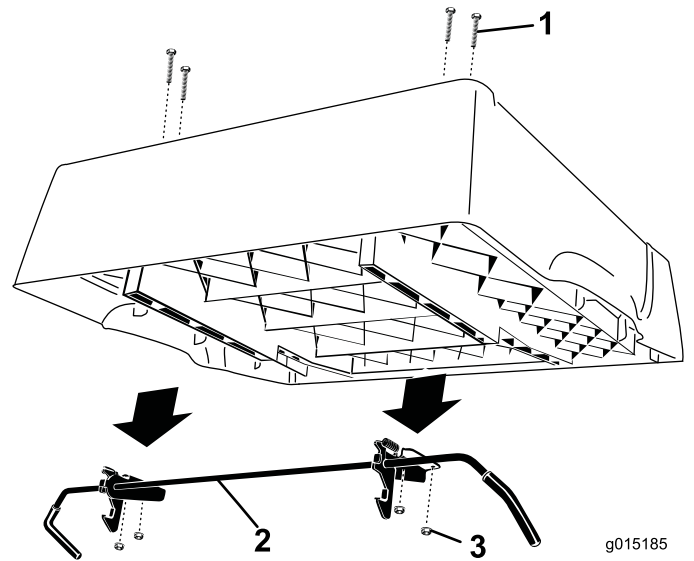

Figure 3

- 1. Carriage bolts—leave in the bed
- 2. Latch rod
- 3. Flange nut

3. Pull the prop rod into the detent slot, securing the box (Figure 1).

⚠ WARNING

A raised box could fall and injure persons that are working beneath it.

- Always use the prop rod to hold the box up before working under the box.
- Remove any load material from the box before raising it.

4. Remove a short battery cable linking any two batteries in the battery bank to remove power from the system (Figure 2).

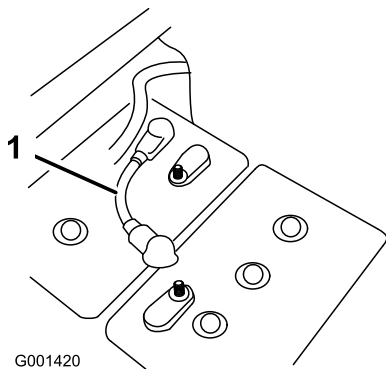

Figure 2

- 1. Short battery cable

5. Remove the 4 flange nuts securing the latch rod brackets to the underside of the box (Figure 3). Remove and save the rod and latches. Leave the carriage bolts in the holes and secure them to the bed with the flange nuts.

2

Installing the Bed Lift

Parts needed for this procedure:

1	Lift bracket, upper
4	Pan-head, Phillips screw (3/8 x 2-1/2 inches)
4	Flange locknut (Whiz lock) (3/8 inch)
1	Lift cylinder support
1	Lift actuator
2	U-bolts
6	Flange locknut (Nylock) (3/8 inch)
2	Carriage bolts (3/8 x 3/4 inch)
1	Clevis pin
1	Cotter pin

Procedure

1. Locate the 4 bosses on the underside of the box on the right side (Figure 4). Using a drill with a 3/8 inch bit, carefully drill up through the bosses to make four holes through the floor of the bed.

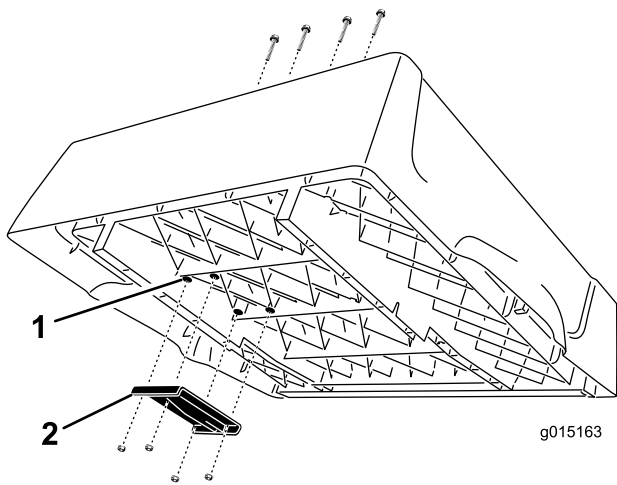

Figure 4

1. Bosses
2. Upper lift bracket

2. Mount the upper lift bracket to the underside of the box with 4 pan-head, Phillips screws (3/8 x 2-1/2 inches) and flange locknuts (Whiz lock) (3/8 inch). Position the bracket as shown in Figure 4.
3. Torque the nuts to 200 in-lb (22.6 N-m).
4. Loosely mount the lift cylinder support to the right end of the rear axle with 2 U-bolts and 4 flange nuts (3/8 inch) while aligning the mounting holes with the holes in the battery tray (Figure 5).

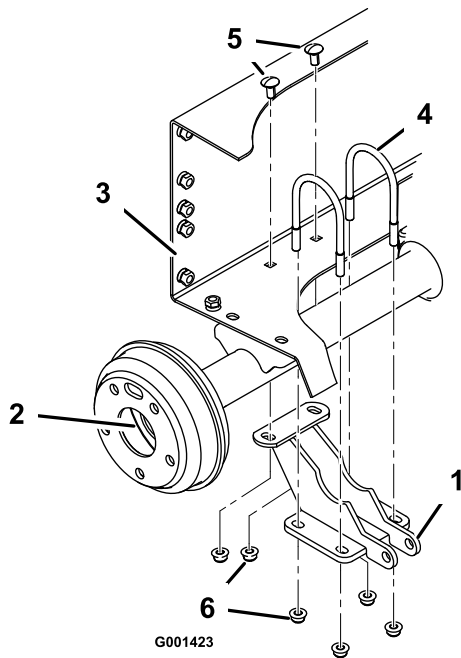

Figure 5

1. Lift cylinder support
2. Right end of the axle
3. Rear frame battery tray
4. U-bolt
5. Carriage bolt, 3/8 x 3/4 inch
6. Flange nut, 3/8 inch

5. Secure the lift cylinder support to the rear frame with 2 carriage bolts (3/8 x 3/4 inch) and 2 flange

nuts (3/8 inch). Tighten the 4 flange nuts on the U-bolts equally to make sure the bracket is aligned to the axle. Tighten the two nuts securing the rear of the bracket to the rear frame (Figure 5).

6. Mount the bottom end of the lift actuator to the lift cylinder support with a clevis pin and cotter pin. Position the components as shown in Figure 6.

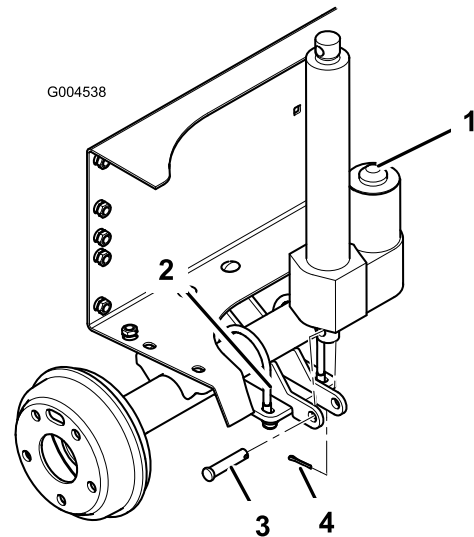

Figure 6

1. Actuator
2. Lift cylinder support
3. Clevis pin
4. Cotter pin

3

Installing the Switch

Parts needed for this procedure:

1	Solenoid
2	Bolt (#10 x 3/4 inch)
2	Nut (#10)
1	Accessory harness
1	Switch
1	Clevis pin, large
1	Cotter pin

Procedure

1. Remove the hood to access the main harness and solenoid plate.
2. Install the solenoid on the existing plate using two bolts (#10 x 3/4 inch) and two nuts (#10) as shown in Figure 7.

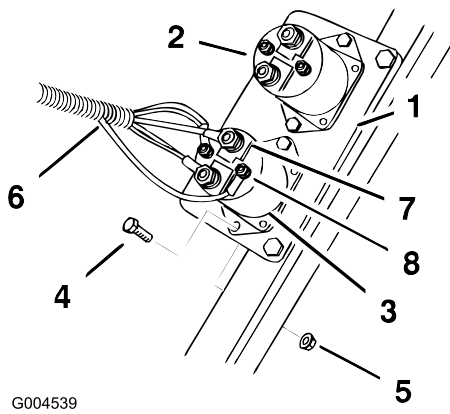

Figure 7

- | | |
|-------------------------|----------------------|
| 1. Solenoid plate | 5. Nut, #10 |
| 2. Solenoid, existing | 6. Accessory harness |
| 3. Solenoid, new | 7. Large posts |
| 4. Bolt, #10 x 3/4 inch | 8. Small posts |

- Attach the accessory harness to the solenoid. Connect a large ring to each large post. Connect a small ring wire to each small post. Secure the wires with the existing fasteners.
- Locate the optional 48v output connector as labeled on the main harness and remove the cap. Connect the accessory harness to the 48v output connector as shown in Figure 8.

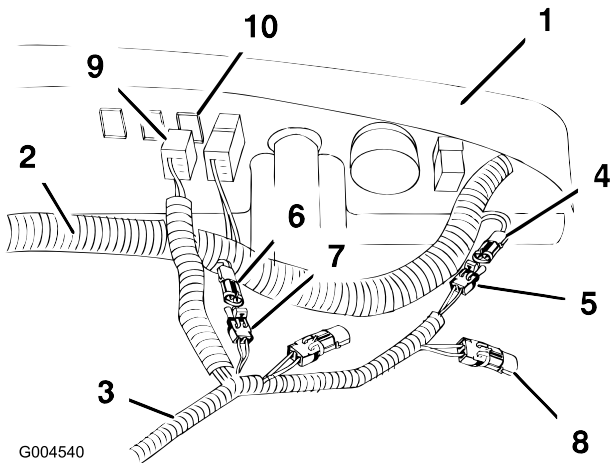

Figure 8

- | | |
|--|--|
| 1. Dash, under side | 6. Box lift kit connector, from main harness |
| 2. Main harness | 7. Box lift kit connector, from accessory harness |
| 3. Accessory harness | 8. Cap 48v connector extension, from accessory harness |
| 4. 48v connector, from main harness | 9. Switch connector |
| 5. 48v connector, from accessory harness | 10. Plug in dash |

- Locate the box lift kit connector on the main harness and remove the cap. Attach accessory harness to box lift kit connector wire from main harness.
- Cap 48v output connector on accessory harness.
- Place the switch connector into position behind the plug in the dash as shown in Figure 8.
- Remove the plug from the hole in the right side of the dash (Figure 9).
- Plug the switch into the accessory connector in the dash. Insert the switch into the hole in the dash (Figure 9).

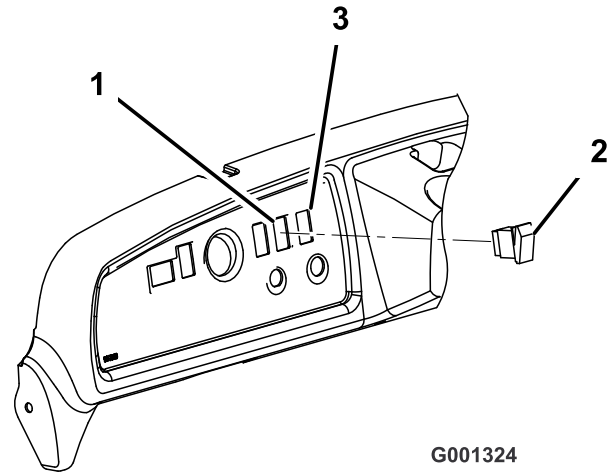

Figure 9

- | | |
|-----------------|--------------------------------|
| 1. Plugged hole | 3. Cut new hole (if required). |
| 2. Switch | |

⚠ WARNING

Loose or improperly secured battery connections could damage the vehicle and cables causing sparks. Sparks can cause the battery gasses to explode, resulting in personal injury.

Always ensure the battery polarity when making connections.

- Plug the switch into the harness connector in the dash. Insert the switch into the hole in the dash (Figure 9).
- Replace the short battery cable removed previously. Torque the nuts securing all battery cables to 120 to 180 inch-lb (13.5 to 21 N·m).
- Coat the battery terminals with Toro battery terminal protector.
- Press the switch upward to extend the actuator rod until it is aligned with the mounting holes in the

upper lift bracket. Secure the rod to the bracket with the large clevis pin and cotter pin.

14. Remove the nuts and bracket securing the prop rod to the underside of the bed. Install the nuts back on the carriage bolts to secure them in the bed and cover the holes.
15. Slide the prop rod forward to remove it from the bracket on the frame. Retain the prop rod components for future use.

Note: If the electric box lift is ever removed, install the prop rod using the existing fasteners and the prop rod bracket.

Operation

Important: When a ratcheting noise is heard, the box lift is completely extended or retracted. Do not continue pressing the switch.

Raising the Bed

⚠ WARNING

Driving the vehicle with the cargo box raised may cause the vehicle to tip or roll easier. The box structure may become damaged if the box is raised for an extended period of time while operating the vehicle.

- Only operate the vehicle when the cargo box is down.
- After a load has been dumped, lower the cargo box.

1. Turn the ignition key to the On position.
2. Push the top of the switch to raise the box.

Lowering the Bed

⚠ CAUTION

The weight of the box may be heavy. Hands or other body parts could be crushed.

Keep hands and other body parts clear when lowering the box.

Push the bottom of the switch to lower the box.

Important: When a ratcheting noise is heard, the box lift is completely extended or retracted. Do not continue pressing the switch.

Note: The actuator may cause slight deformation to the bed after it is fully lowered and before the actuator clutch engages. Release the switch when a ratcheting noise is heard.

Notes:



Count on it.