



Count on it.

Parts Catalog

Workman® MDX Utility Vehicle

Model No. 07273TC—Serial No. 310000801 and Up

Ordering Replacement Parts

To order replacement parts, please supply the part number, the quantity, and the description of each part desired.

Understanding Reference Numbers

Each identified part in an illustration has a reference number. The reference number for a part also appears in the parts list, along with other information about the part.

This catalog uses two special reference number formats, one to indicate parts in a service assembly and another to indicate the quantity of a given part in an illustration.

Service Assembly Reference Numbers

Parts in service assemblies have reference numbers in the form a:b. The a represents the reference number of the entire service assembly and the b represents a sequential number unique to each part within the service assembly.

For example, a wheel assembly might be identified by reference number 6, the tire by 6:1, the valve by 6:2, and the wheel by 6:3. When you order the assembly identified by reference number 6, you receive all parts identified by reference numbers 6:1, 6:2, and 6:3. However, you may also order any part individually. Reference numbers of this type appear in illustration and in parts lists.

Reference Numbers Indicating Quantity

In an illustration, if a reference number indicates more than one part, the reference number has the form nX y. The n represents the quantity of the part, the X is the multiplication symbol, and the y represents the reference number.

For example, in an illustration, the reference number 2X 37 means that two of the parts identified by reference number 37 are indicated.

List of Abbreviations

AR: as required

ASM: assembly

BBC: blade brake control

BHTF: button head thread forming

CARR: carriage

CCW: counter clockwise

CW: clockwise

DEG: degrees

ECM: electronic control module

EXT: external

FH: flat head

GA: gauge

HD: heavy-duty

HF: hex flange

HH: hex head

HHF: hex head flange

HHFTF: hex head flange thread forming

HJ: hex jam

HLH: hex lag head

HOC: height-of-cut

HSBH: hex socket button head

HSFH: hex socket flat head

HSH: hex socket head

HWH: hex washer head

HWHTF: hex washer head thread forming

HYD: hydraulic

LH: left hand

LP: Liquid Propane

NI: nylon insert

NPTF: national pipe thread fine

PFH: phillips flat head

PPH: phillips pan head

PPHTF: phillips pan head thread forming

PRH: phillips round head

PTH: phillips truss head

PTO: power-take-off

RH: right hand

ROPS: roll-over protection system

RRB: rear roller brush

SFH: slotted fillister head

SHH: slotted hex head

SHWH: slotted hex washer head

SPH: slotted pan head

SQH: square head

SRH: slotted round head

STD: standard

TAP: self tapping

TTH: torx truss head

Contents

Dash Assembly	4
Pedal Box Assembly	6
Shifter Assembly	7
Front Frame Assembly	8
Seat Base Assembly	9
Front Tire, Spindle and Tie Rod Assembly	11
Engine and Clutch Assembly	13
Primary Clutch Assembly No. 119-0800	15
Starter Generator Assembly No. 99-7108	16
Rear Tire and Transaxle Assembly	17
Transaxle Assembly No. 119-0760	18
LH Rear Brake Assembly No. 114-8332	20
RH Rear Brake Assembly No. 114-8331	21
Secondary Clutch Assembly No. 119-0803	22
Oil Filter and Air Cleaner Assembly	23
Air Cleaner Assembly No. 99-7120	24
Upper Steering Assembly	25
Steering Box Assembly No. 112-3130	26
Box and Tailgate Installation Assembly	27
Box and Tailgate Assembly	28
Hood and Fender Assembly	29
Frame Assembly	30
Master Cylinder and Brake Line Assembly	31
Master Cylinder Assembly No. 104-6782	32
Attachments and Accessories	33

Dash Assembly

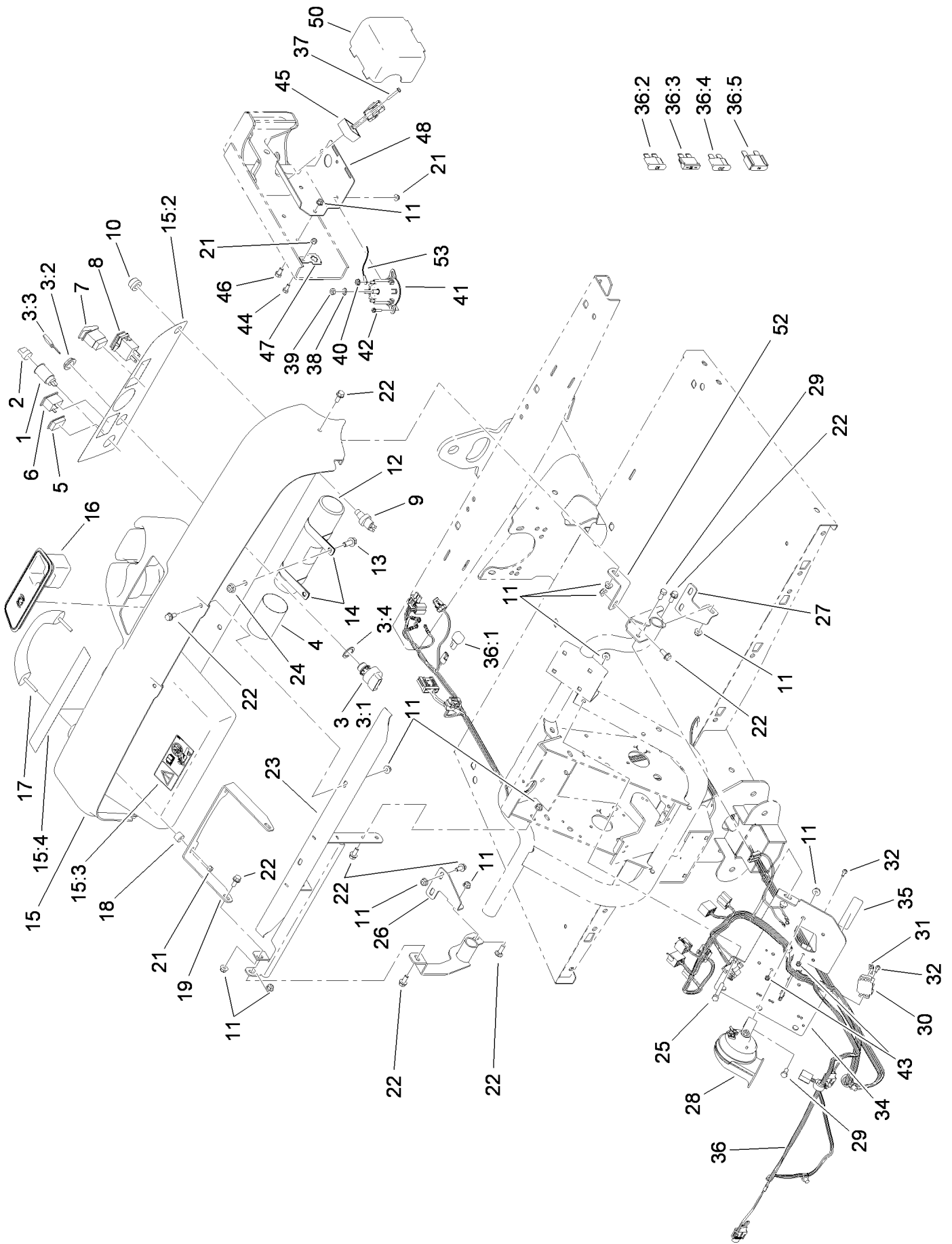

Dash Assembly (continued)

<i>Ref.</i>	<i>Part Number</i>	<i>Qty.</i>	<i>Description</i>	<i>Ref.</i>	<i>Part Number</i>	<i>Qty.</i>	<i>Description</i>
1	99-7411	1	Point-Power	25	322-11	2	Screw-HH
2	99-7416	1	Cap	26	114-8304	1	Bracket-Dash Mount, RH
3	112-3323	1	Ignition Switch ASM	27	114-8312	1	Bracket-Dash Mount, LH
3:1		1	Switch-Ignition ●	28	110-2594	1	Horn ASM
3:2	108-8660	1	Nut-Mounting	29	322-3	2	Screw-HH
3:3	99-7418	1	Key-Ignition	30	42862	1	Block-Terminal, Ground
3:4	108-8659	1	Washer-Backup	31	42863	1	Strip-Jumper
4	104-7048	1	Cap-Housing	32	32105-13	4	Screw-HWH
5	99-7420	1	Plug-Hole	34	112-3376-03	1	Plate-Mount, Electrical
6	99-7410	1	Indicator-Light, Low-Oil Pressure	35	112-3325	1	Decal-Block, Fuse
7	95-8999	1	Switch	36	119-5774	1	Harness-Wire
8	94-4208	1	Hourmeter	36:1	100-4918	1	Diode
9	112-3324	1	Switch-Horn	36:2	218-578	1	Fuse-10 Amp
10	112-3313	1	Cap And Nut ASM	36:3	109355	1	Fuse-15 Amp
11	104-8300	21	Nut-Flange, NI	36:4	109101	1	Fuse-20 Amp
12	104-7050	1	Tube-Manual	36:5	114-3342	1	Fuse-Maxi, 60 Amp
13	3234-11	2	Screw-HHF	37	100-4352	1	Screw-HWH
14	2412-133	2	R-Clamp	38	3255-8	2	Washer-Lock
15	114-8310	1	Dash ASM	39	3220-2	2	Nut-Jam
15:2	117-5001	1	Decal-Panel, Control	40	32149-8	2	Nut-Keps
15:3	104-6581	1	Decal-Danger	41	114-3315	1	Solenoid-12 Vdc
15:4	115-2412	1	Decal-No Storage	42	3234-33	2	Screw-HHF
16	104-6930	1	Plug-Rubber	43	3296-2	4	Nut-Lock, NI
17	112-3320	1	Handle-Grip	44	321-3	1	Screw-HH
18	114-8301	2	Spacer	45	119-9492	1	Regulator-Voltage
19	112-3391-03	1	Bracket-Grip, Handle	46	322-2	2	Screw-HH
21	104-7201	5	Nut-HF	47	114-5502	1	Clip-Fuse
22	110-5053	15	Screw-Flange	48	119-0752-03	1	Mount-Component
23	115-7651-03	1	Dash Support ASM	50	112-3027	1	Cover-Controller
24	104-8301	2	Nut-Flange, NI	52	114-8305	1	Angle-Mount, Dash (LH)
				53	112-3537	1	Cable-Battery, Positive

● Not serviced separately

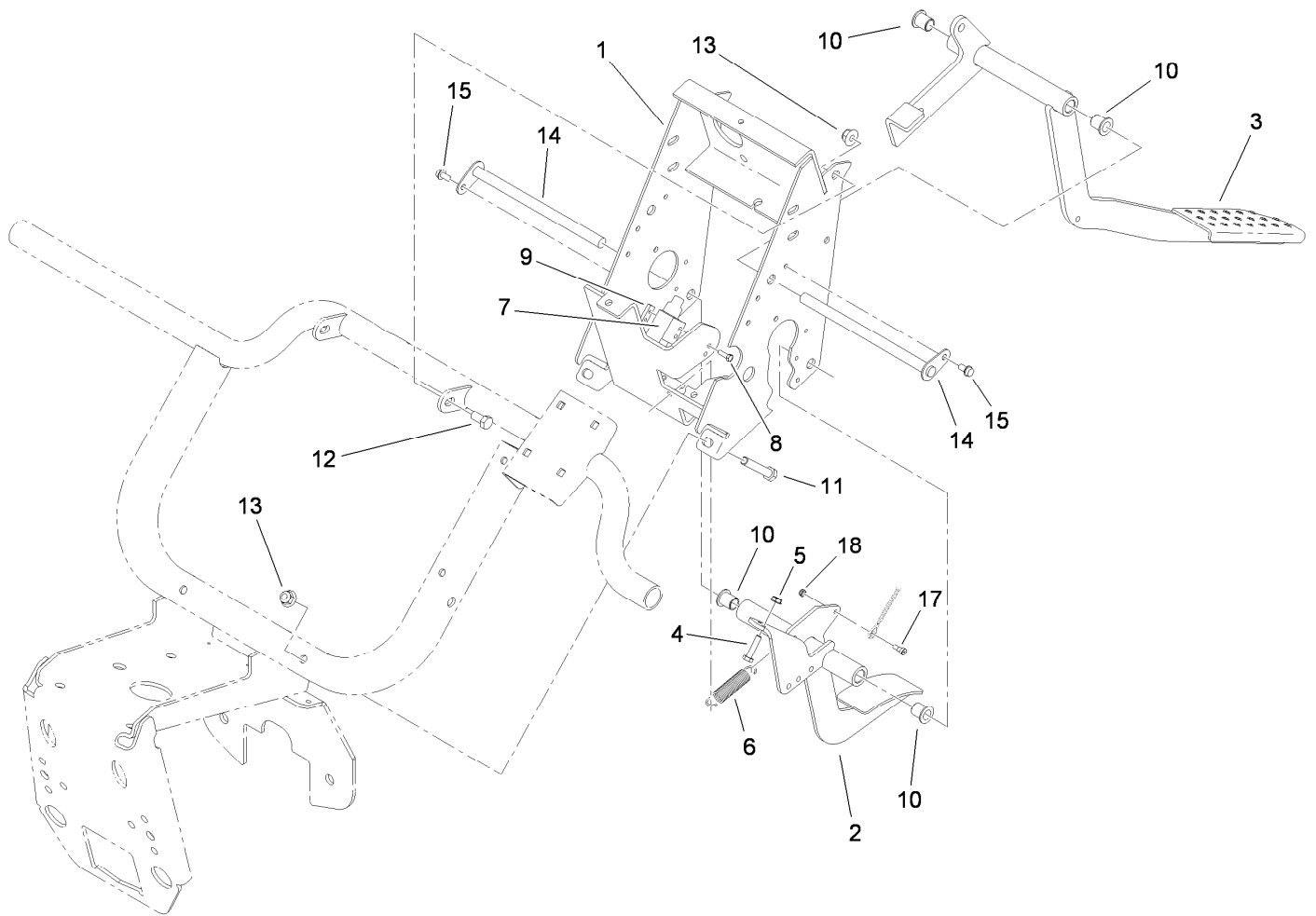

Pedal Box Assembly

<i>Ref.</i>	<i>Part Number</i>	<i>Qty.</i>	<i>Description</i>	<i>Ref.</i>	<i>Part Number</i>	<i>Qty.</i>	<i>Description</i>
1	119-0748-03	1	Pedal Support Frame ASM	10	256-155	4	Bushing-Flange
2	115-7630-03	1	Throttle Pedal ASM	11	323-11	2	Screw-HH
3	112-3314-03	1	Brake Pedal ASM	12	323-4	2	Screw-HH
4	321-7	2	Screw-HH	13	104-8301	4	Nut-Flange, NI
5	32149-2	2	Nut-Keps	14	104-7164	2	Pivot-Pedal
6	104-6415	1	Spring-Return, Pedal	15	32144-4	2	Screw-HWH
7	99-7407	1	Switch	17	115-7632	1	Bolt-Shoulder
8	3290-134	2	Screw	18	3296-47	1	Nut-Lock, NI
9	1-633181	1	Plate-Tapped				

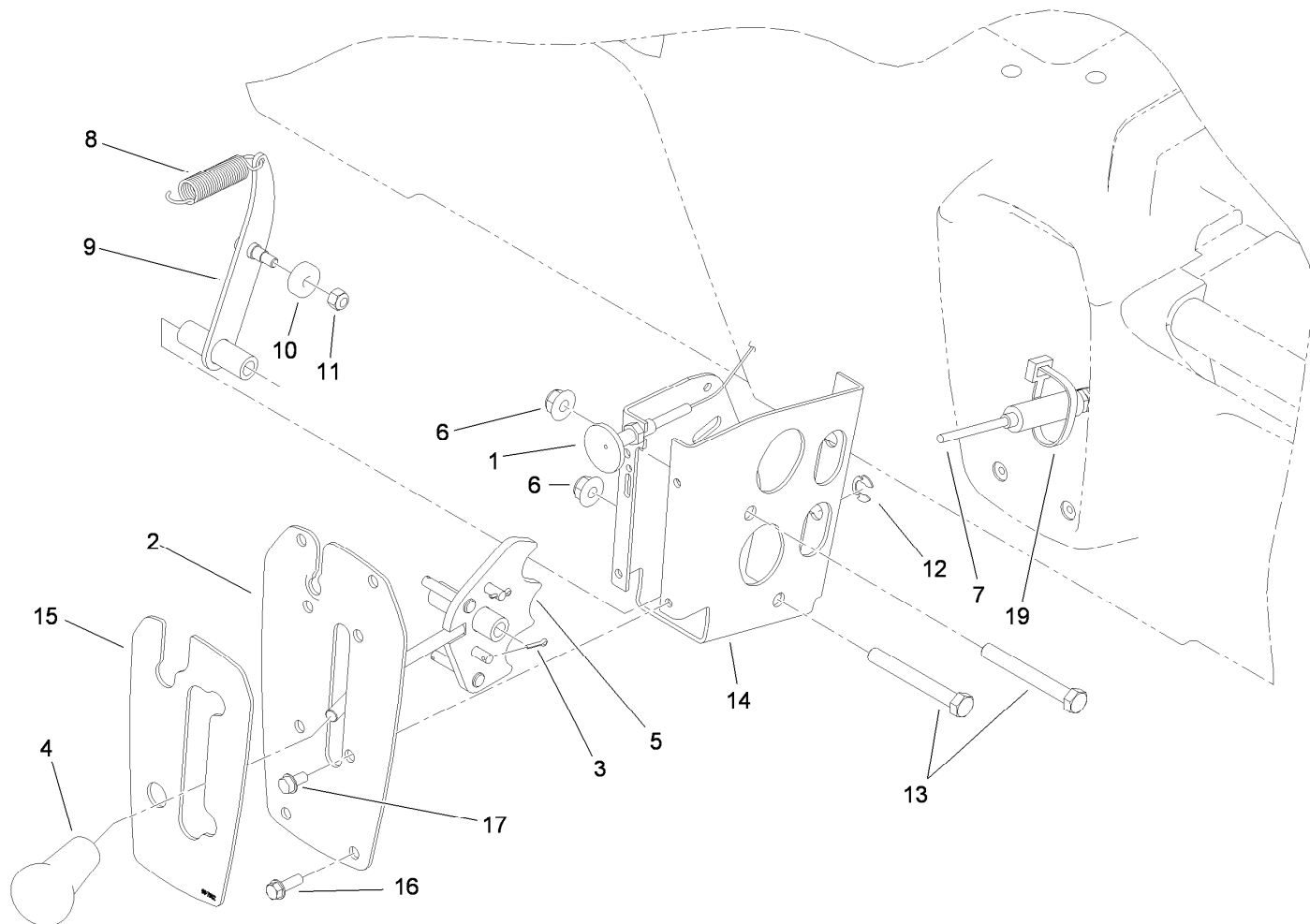

Shifter Assembly

<i>Ref.</i>	<i>Part Number</i>	<i>Qty.</i>	<i>Description</i>
1	99-7111	1	Cable-Choke
2	99-7887-03	1	Plate-Shifter
3	3272-5	2	Pin-Cotter
4	99-7981	1	Knob-Grip, Soft
5	114-2719	1	Plate-Detent
6	104-8301	2	Nut-Flange, NI
7	115-7679	2	Tension Cable Control ASM
8	104-6415	1	Spring-Return, Pedal
9	108-3138	1	Arm-Detent

<i>Ref.</i>	<i>Part Number</i>	<i>Qty.</i>	<i>Description</i>
10	251-307	1	Bearing-Ball
11	3296-42	1	Nut-Lock, NI
12	32151-101	2	E-Ring
13	323-14	2	Screw-HH
14	108-3141-03	1	Bracket-Shift
15	99-7952	1	Decal-Shifter
16	32105-15	4	Screw
17	32144-4	4	Screw-HWH
19	3290-378	1	Tie-Cable

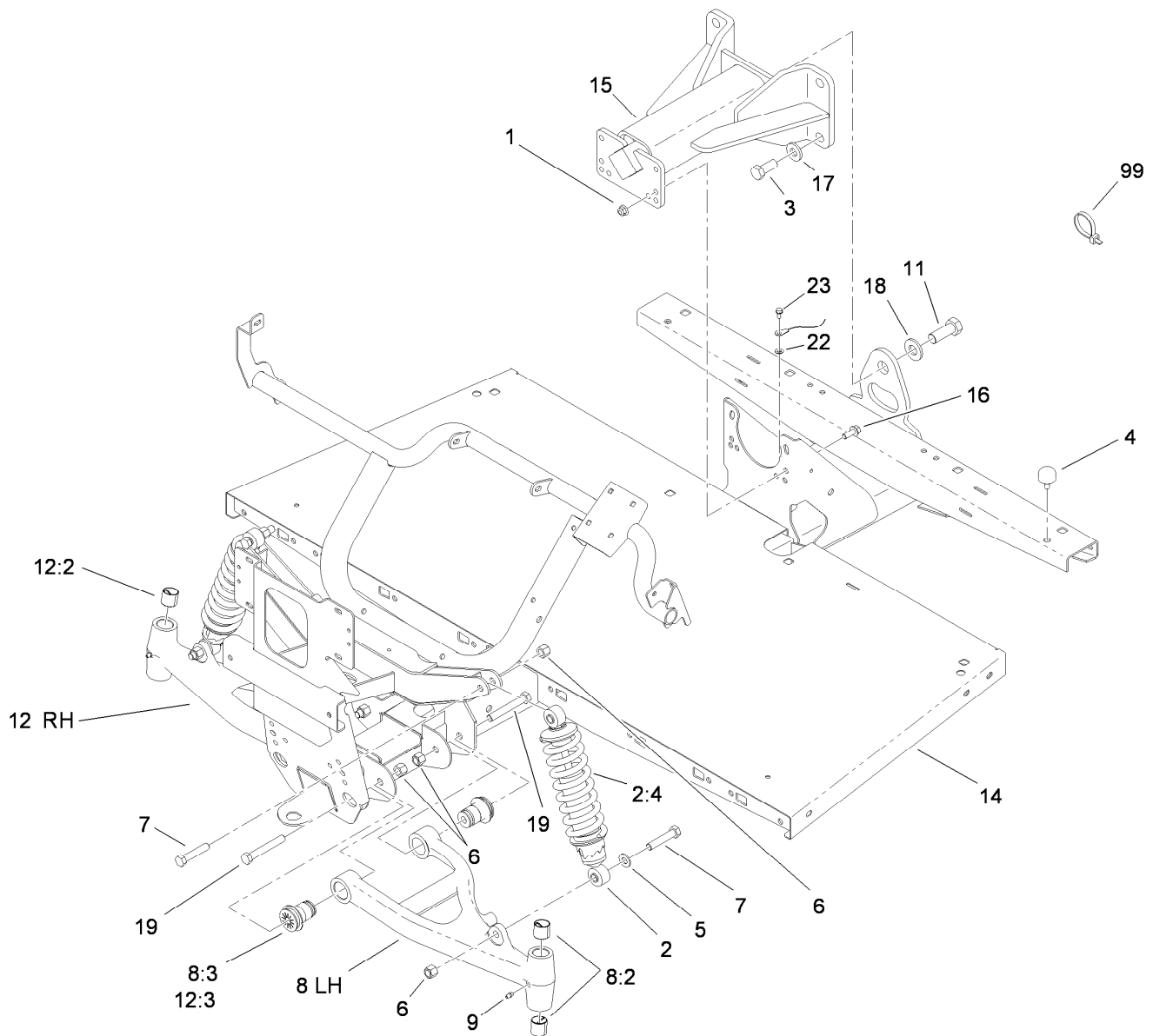

Front Frame Assembly

<i>Ref.</i>	<i>Part Number</i>	<i>Qty.</i>	<i>Description</i>	<i>Ref.</i>	<i>Part Number</i>	<i>Qty.</i>	<i>Description</i>
1	104-8301	4	Nut-Flange, NI	12	114-8314	1	RH A-Arm ASM
2	112-2975	2	Shock/Spring ASM	12:2	3-0348	2	Bushing
2:4	112-3383	1	Spring	12:3	87-1450	2	Bushing-Flange
3	327-4	4	Screw-HH	14	112-3340-03	1	Front Frame ASM
4	87-2440	1	Bumper-Rubber	15	99-7700	1	Pivot Yoke ASM
5	51-3500	2	Washer	16	3234-11	4	Screw-HHF
6	3296-23	8	Nut-Lock, NI	17	99-7667	4	Washer-Flat
7	325-10	4	Screw-HH	18	87-3060	1	Washer-Hardened
8	114-8313	1	LH A-Arm ASM	19	325-14	4	Screw-HH
8:2	3-0348	2	Bushing	22	3254-16	1	Washer-Lock/Int
8:3	87-1450	2	Bushing-Flange	23	32144-4	1	Screw-HWH
9	302-5	2	Fitting-Grease	99	3290-379	12	Tie-Cable
11	328-24	1	Screw-HH				

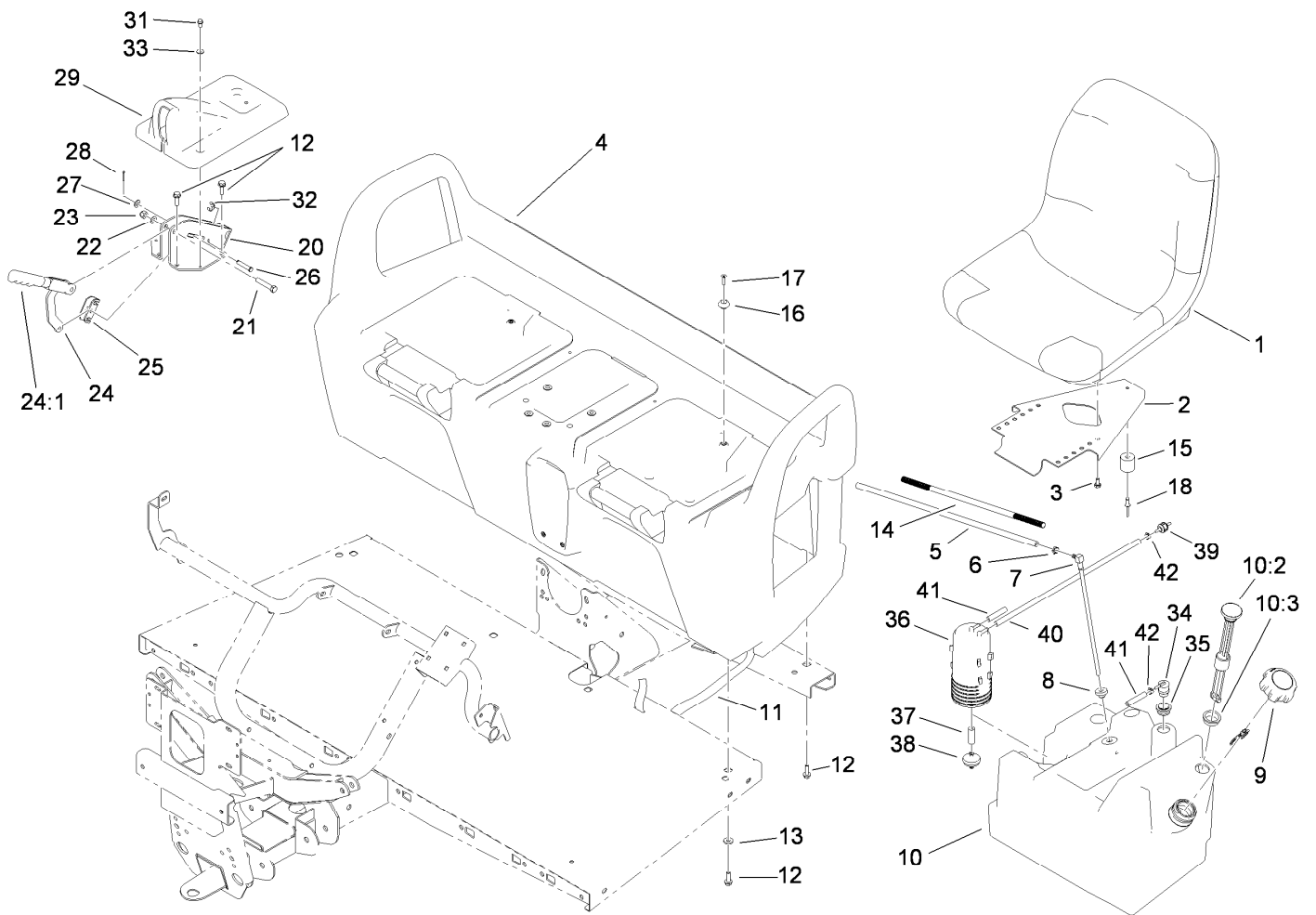

Seat Base Assembly

<i>Ref.</i>	<i>Part Number</i>	<i>Qty.</i>	<i>Description</i>	<i>Ref.</i>	<i>Part Number</i>	<i>Qty.</i>	<i>Description</i>
1	112-2923	2	Seat ASM	21	323-10	1	Screw-HH
2	99-7829	2	Bracket-Seat	22	3290-477	1	Washer-Curved
3	33114-016	8	Screw-HH	23	3296-39	1	Nut-Lock, NI
4	104-6847	1	Seat Base ASM	24	104-6842	1	Lever-Brake, Park
5	110-4103	1	Hose-Fuel	24:1	106-7972	1	Grip-Handle
6	2412-98	1	Clamp	25	87-3480	1	Bracket-Equalizer, Cable
7	99-7264	1	Pipe-Stand	26	94-3829	1	Pin-Clevis
8	46-6560	1	Bushing	27	3256-23	1	Washer-Flat
9	115-7788	1	Cap-Fuel	28	3272-6	1	Pin-Cotter
10	119-0784	1	Fuel Tank ASM	29	104-7014	1	Cover-Brake, Parking
10:2	99-7262	1	Gauge-Fuel	31	32144-4	2	Screw-HWH
10:3	95-8972	1	Grommet	32	32120-47	2	Ring-Retaining, External
11	3339-175	1	Strapping-Web, 48 Inch	33	3256-1	2	Washer-Flat
12	3234-17	12	Screw-HHF	34	114-0285	1	Valve-Rollover
13	88-7200	8	Washer-Flat	35	114-0284	1	Grommet
14	112-3337	1	Conduit-Line, Fuel	36	117-1221	1	Canister-Carbon, 800Cc
15	99-7830	2	Rubber Receptical ASM	37	106-5317	1	Hose-Fuel
16	99-7833	2	Post-Holding	38	115-7854	1	Filter-Fuel, Inline
17	32108-5	2	Screw-FH	39	115-7868	1	Valve-Check, Vacuum
18	3290-412	2	Rivet	40	75-4701	1	Hose-Fuel
20	104-6844-03	1	Support-Brake, Park				

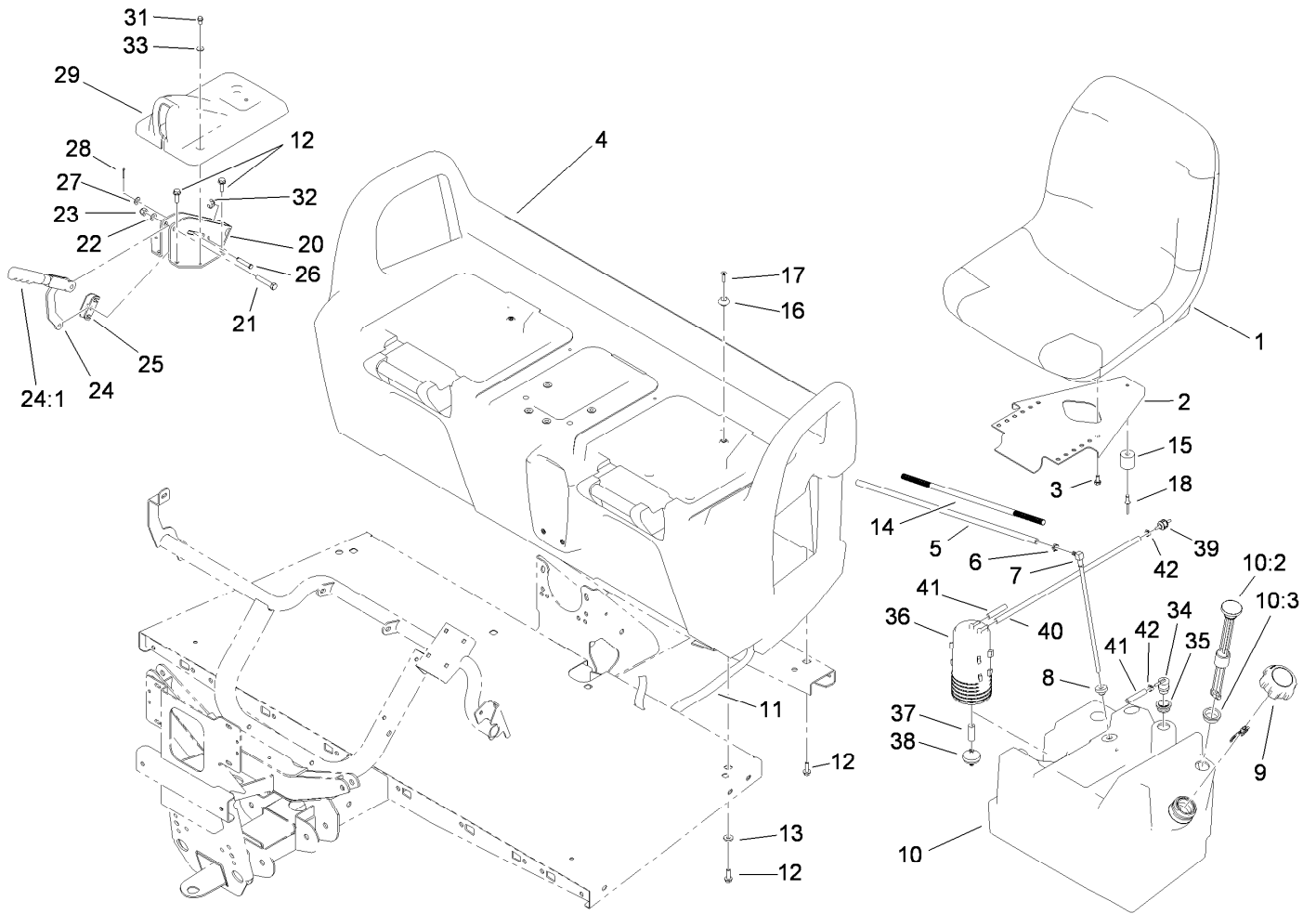

Seat Base Assembly (continued)

<i>Ref.</i>	<i>Part Number</i>	<i>Qty.</i>	<i>Description</i>
41	110-8751	1	Hose-Fuel
42	2412-146	2	Clamp-Hose

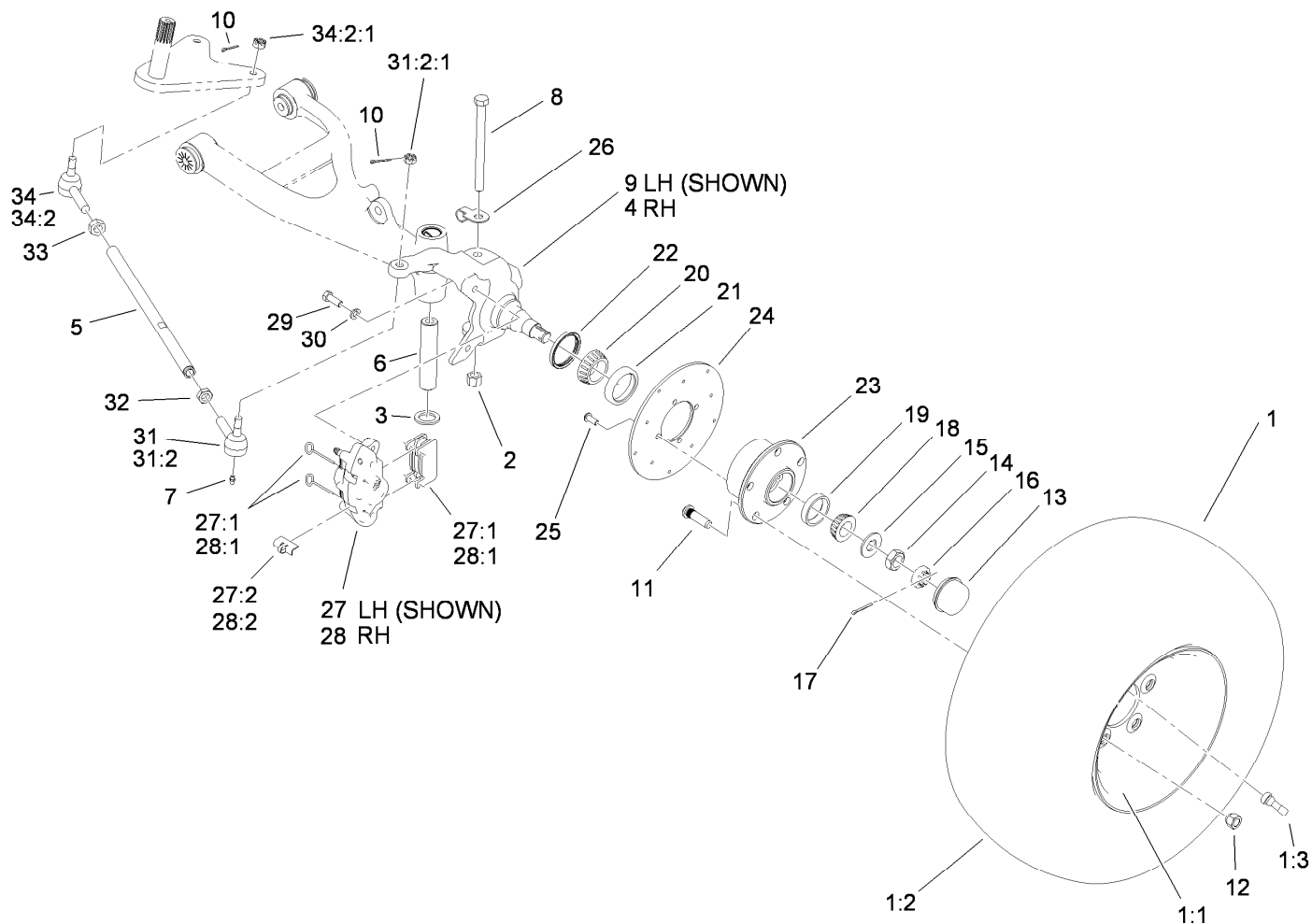

Front Tire, Spindle and Tie Rod Assembly

Ref.	Part Number	Qty.	Description	Ref.	Part Number	Qty.	Description
1	104-7290	2	Tire And Wheel ASM	17	3272-12	2	Pin-Cotter
1:1	104-7288	1	Wheel	18	254-94	2	Bearing-Cone, Tapered
1:2	104-7289	1	Tire	19	254-72	2	Bearing-Cup, Tapered
1:3	232-27	1	Stem-Valve	20	254-106	2	Cone-Bearing, Tapered
2	3296-23	2	Nut-Lock, NI	21	254-107	2	Cup-Bearing, Tapered
3	256-115	2	Washer-Thrust	22	108-7019	2	Seal-Shaft
4	112-3167	1	Spindle-RH	23	104-6809	2	Hub
5	115-7654	2	Tie Rod	24	104-6891	2	Rotor
6	99-7499	2	Sleeve-Kingpin	25	3274-55	8	Screw-HSBH
7	302-5	4	Fitting-Grease	26	112-3311	2	Clip-Hose
8	325-20	2	Screw-HH	27	112-3150	1	Caliper-LH
9	112-3166	1	Spindle-LH	27:1	107-0708	1	Friction Pad And Pin Kit
10	3272-7	4	Pin-Cotter	27:2	112-3152	1	Spring-Rattle, Anti
11	10-6830	10	Stud-Type, Drive	28	112-3151	1	Caliper-RH
12	242-50	10	Nut-Lug	28:1	107-0708	1	Friction Pad And Pin Kit
13	241-119	2	Cap-Dust	28:2	112-3152	1	Spring-Rattle, Anti
14	3220-7	2	Nut-Jam	29	323-6	4	Screw-HH
15	93-0309	2	Washer-Tab	30	3253-21	4	Washer-Lock
16	93-0307	2	Nut-Lock, Retainer	31	112771-03	2	LH Ball Joint ASM

● Not serviced separately

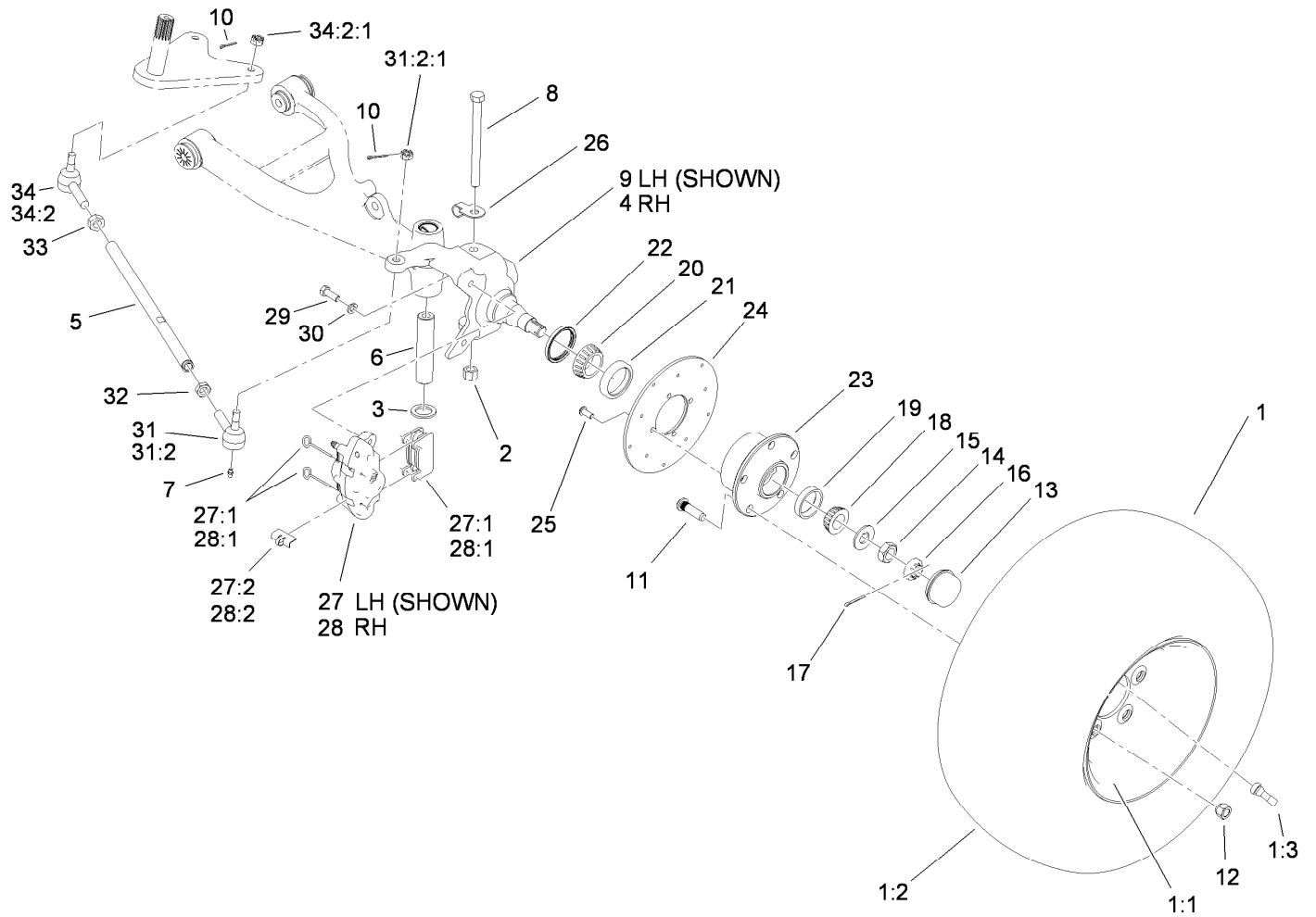

Front Tire, Spindle and Tie Rod Assembly (continued)

Ref.	Part Number	Qty.	Description
31:2		1	Joint-Ball, LH ●
31:2:1	915031	1	Nut
32	3218-21	2	Nut-Jam
33	3220-11	2	Nut-Jam

Ref.	Part Number	Qty.	Description
34	112772-03	2	RH Ball Joint ASM
34:2		1	Joint-Ball, RH ●
34:2:1	915031	1	Nut

● Not serviced separately

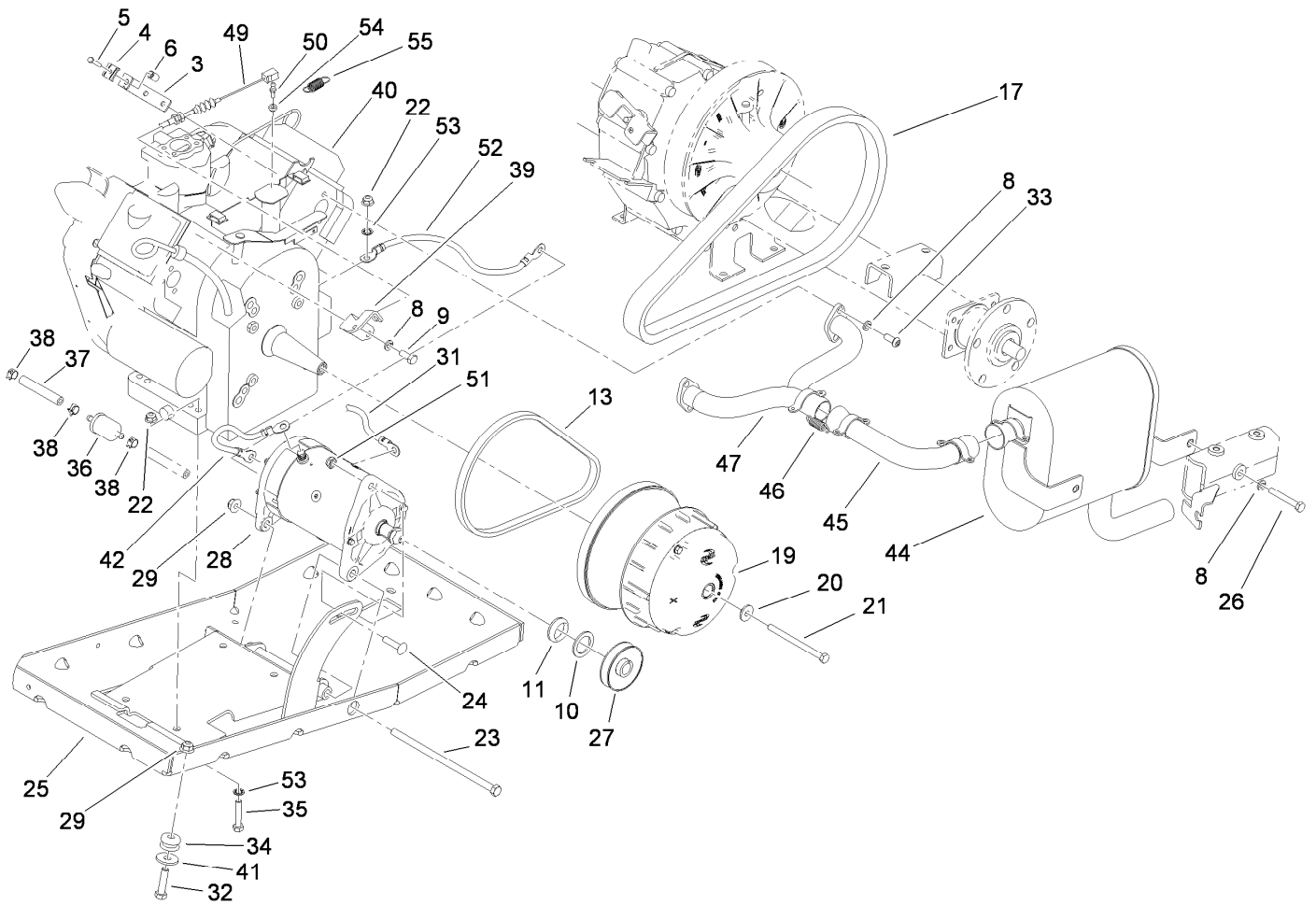

Engine and Clutch Assembly

Ref.	Part Number	Qty.	Description	Ref.	Part Number	Qty.	Description
3	107-0319	1	Bracket-Cable	28	99-7108	1	Starter Generator ASM
4	81-1690	1	Clamp-Cable	29	104-8301	3	Nut-Flange, NI
5	3290-432	1	Screw-HH	31	115-8109	1	Harness-Wire, Engine
6	32148-14	1	Insert-Threaded	32	323-8	2	Screw-HH
8	3253-4	8	Washer-Lock	33	3274-96	4	Screw-HSBH
9	66-3160	2	Screw-Cap	34	63-9750	2	Mount
10	119-0868	1	Washer-Flat	35	322-9	4	Screw-HH
11	119-9481	1	Seal-V Ring	36	94-2690	1	Filter-Fuel
13	112-2911	1	Belt-Starter	37	114-3765	1	Hose-Fuel
17	119-0711	1	Belt-Variable	38	2412-98	3	Clamp
19	119-0800	1	Clutch-Primary	39	115-2393	1	Bracket-Cable
20	119-0724	1	Washer-Flange	40	117-2714	1	Engine-Briggs & Stratton, 295440-0153-G2 ●
21	119-0722	1	Screw-HH	41	2844	2	Washer
22	104-8300	4	Nut-Flange, NI	42	99-7403	1	Cable-Negative
23	323-30	1	Screw-HH	44	119-0746	1	Muffler
24	112-6950	1	Screw-CARR	45	119-0717	1	Pipe-Exhaust
25	119-0709-03	1	Engine Tray ASM	46	104-6478	4	Spring-Coupler, Exhaust
26	322-11	2	Screw-HH	47	104-6476	1	Manifold-Engine
27	119-9482	1	Pulley-Drive				

● Obtain parts from www.briggsandstratton.com

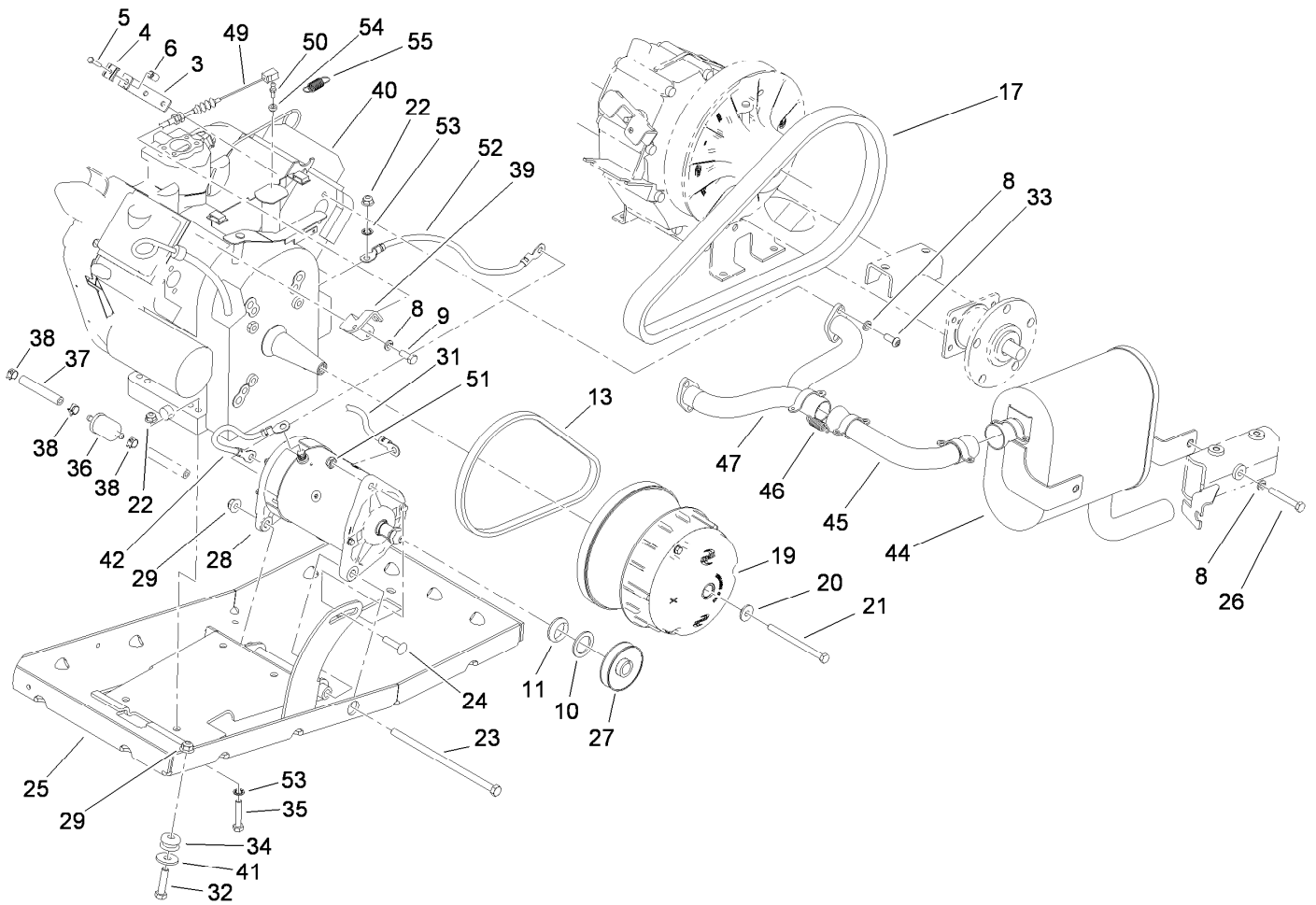

Engine and Clutch Assembly (continued)

<i>Ref.</i>	<i>Part Number</i>	<i>Qty.</i>	<i>Description</i>	<i>Ref.</i>	<i>Part Number</i>	<i>Qty.</i>	<i>Description</i>
49	115-7612	1	Cable-Accelerator	53	3254-2	2	Washer-Lock, Internal
50	99-7847	1	Ball-Stud	54	110-2619	1	Keeper-Spring
51	3296-69	1	Nut-Lock NI	55	71-5470	1	Spring-Brake
52	94-2777	1	Wire-Ground				

● Obtain parts from www.briggsandstratton.com

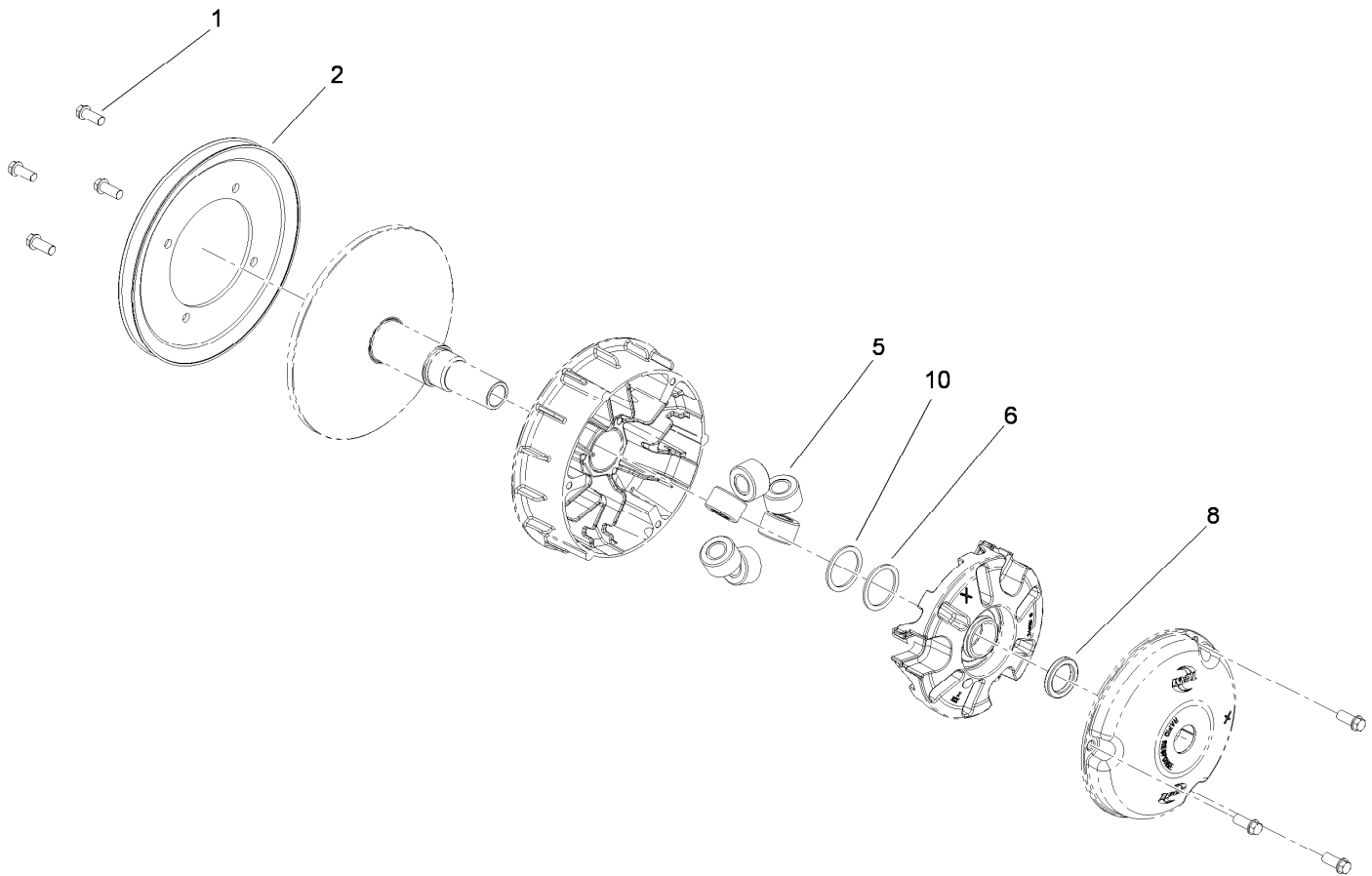

Primary Clutch Assembly No. 119-0800

<i>Ref.</i>	<i>Part Number</i>	<i>Qty.</i>	<i>Description</i>
1	49-2040	7	Screw-HWHTF
2	119-0813	1	Pulley-Primary
5	119-0804	6	Weight-Roller (47Gm)
6	119-0812	1	Shim-Spider
8	119-0806	1	Shim-Limiter (.250)
10	119-0815	1	Shim-Spider

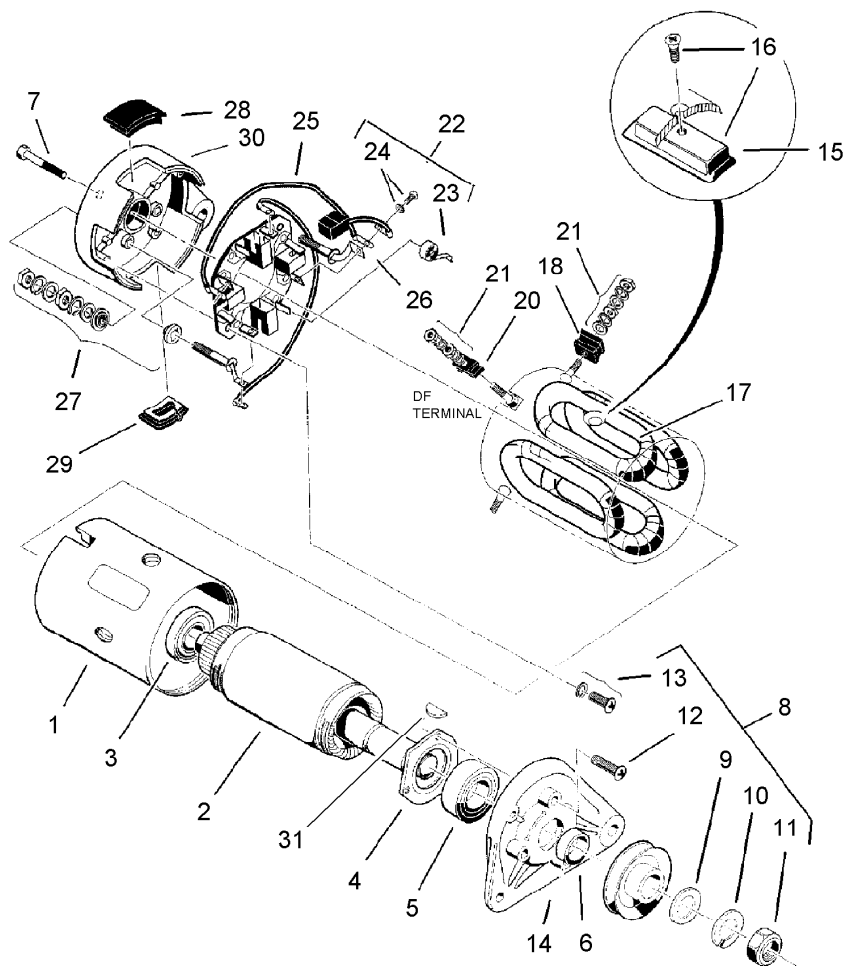

Starter Generator Assembly No. 99-7108

Ref.	Part Number	Qty.	Description	Ref.	Part Number	Qty.	Description
1		1	Yoke ●	16	104-1221	1	Set-Pole And Screw
2	104-1210	1	Armature Kit	17	104-1222	1	Field Stator Coil ASM
3	104-1211	1	Bearing-Ball, Rear	18		2	F Mold ●
4	104-1212	1	Retainer	20		1	Df Mold ●
5	104-1213	1	Bearing-Ball, Front	21	104-1224	1	Nut And Washer Set
6	104-1214	1	Spacer	22	104-1225	1	Brush Holder Kit
7	104-1215	2	Bolt	23	104-1226	4	Spring-Brush
8		1	Nut And Screw Set ●	24	104-1227	1	Brush And Screw Set
9	104-1216	1	Washer-Plain	25		2	Brush Connector ASM ●
10	104-1217	1	Washer-Spring	26		2	A Terminal ASM ●
11	104-1218	1	Nut-Hex	27	104-1228	2	Screw And Mold ASM
12		3	Screw-Flange ●	28		1	Cover Set ●
13	104-1219	2	Set-Screw	29		1	Cover B ●
14	104-1220	1	Bracket-Front	30		1	Bracket-Rear ●
15		4	Pole ●	31	3257-3	1	Key-Woodruff

● Not serviced separately

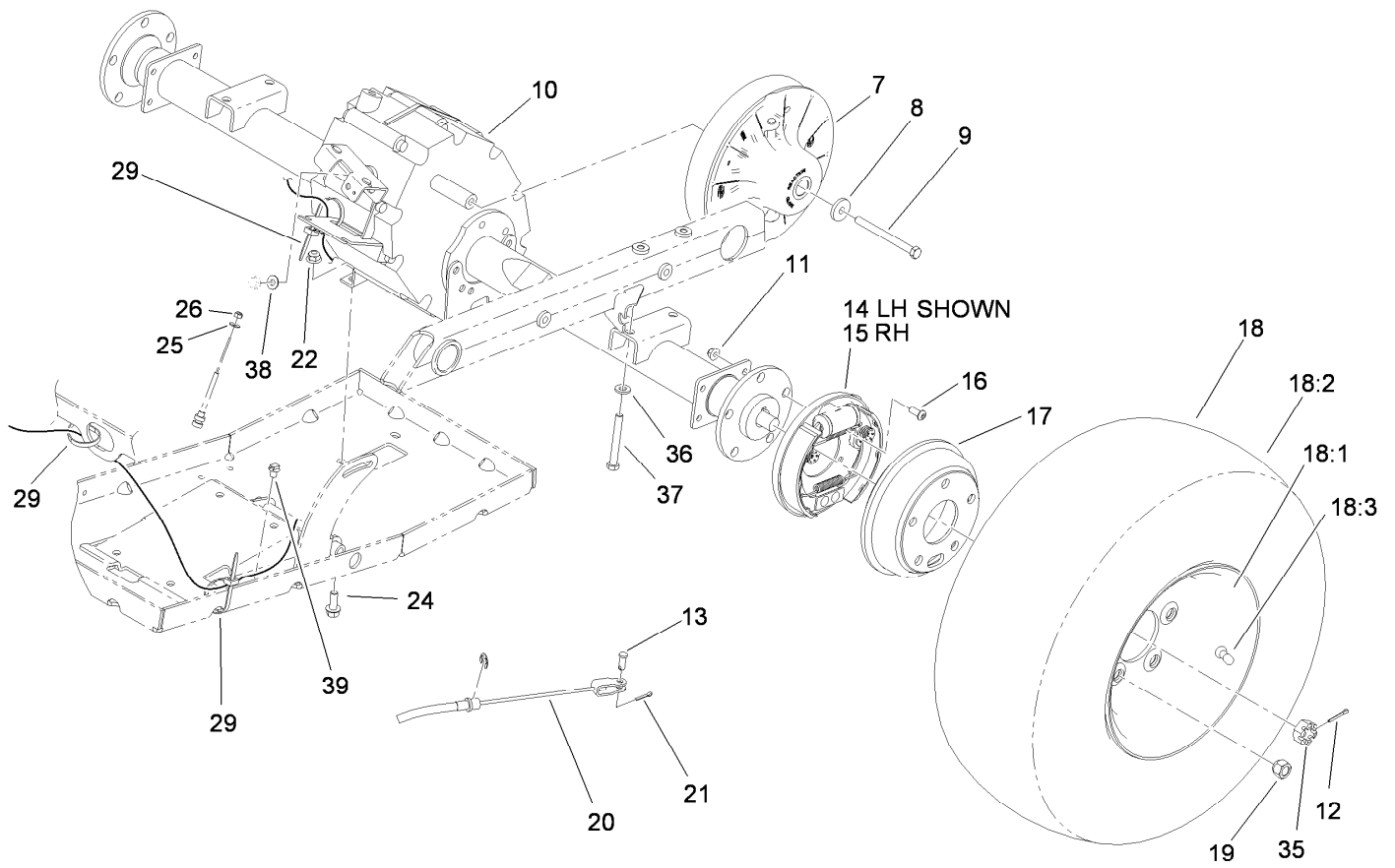

Rear Tire and Transaxle Assembly

Ref.	Part Number	Qty.	Description	Ref.	Part Number	Qty.	Description
7	119-0803	1	Clutch-Secondary	18:3	232-27	1	Stem-Valve
8	104-6563	1	Washer-Stepped	19	242-50	10	Nut-Lug
9	119-0723	1	Screw-HH, Lock	20	112-3309	2	Cable-Brake
10	119-0760	1	Transaxle	21	3272-10	2	Pin-Cotter
11	104-8300	8	Nut-Flange, NI	22	104-8301	4	Nut-Flange, NI
12	3272-12	2	Pin-Cotter	24	3234-11	4	Screw-HHF
13	283-62	2	Pin-Clevis	25	3256-49	2	Washer-Flat
14	114-8332	1	LH Brake ASM	26	3296-2	2	Nut-Lock, NI
15	114-8331	1	RH Brake ASM	29	3290-378	3	Tie-Cable
16	3274-55	8	Screw-HSBH	35	104-1656	2	Nut-Castle
17	104-6500	2	Drum-Brake	36	100-4852	4	Washer-Hardened
18	104-7282	2	Tire And Wheel ASM	37	323-14	4	Screw-HH
18:1	104-7279	1	Wheel	38	87-8640	1	Washer-Flat
18:2	104-7281	1	Tire	39	32180-030	1	Clip-Harness

Transaxle Assembly No. 119-0760

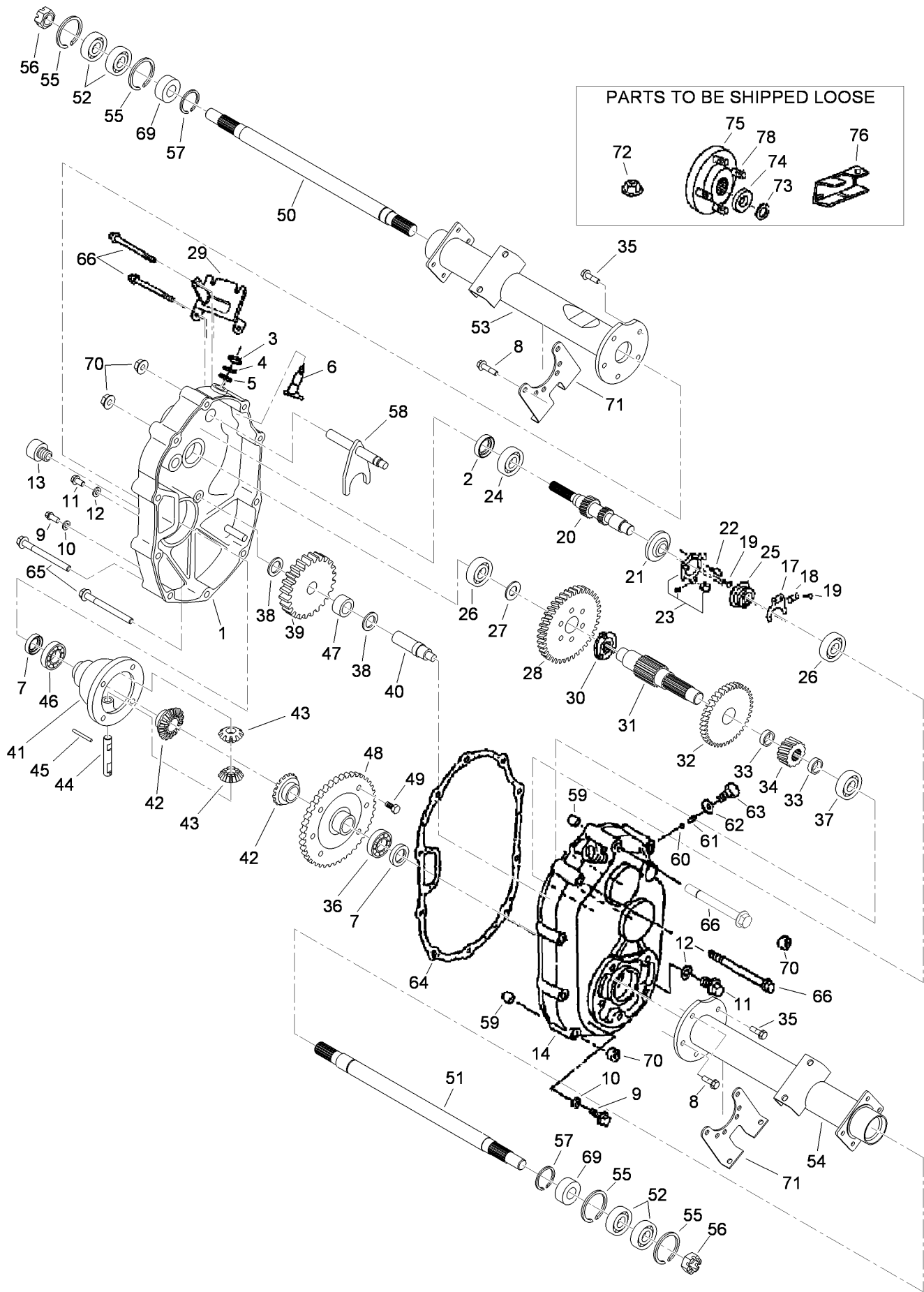

Transaxle Assembly No. 119-0760 (continued)

<i>Ref.</i>	<i>Part Number</i>	<i>Qty.</i>	<i>Description</i>	<i>Ref.</i>	<i>Part Number</i>	<i>Qty.</i>	<i>Description</i>
1	104-1601	1	Case-LH, Complete	40	104-1640	1	Shaft-Counter
2	104-1602	1	Seal-Oil	41	104-1641	1	Case-Differential
3	104-1603	1	Seal-Oil	42	104-1642	2	Gear-Side, Differential
4	104-1604	1	Ring-Snap	43	104-1643	2	Pinion-Differential
5	104-1605	1	Spacer	44	104-1644	1	Shaft-Differential
6	104-1606	1	Shaft-Selector	45	104-1645	1	Pin
7	104-1607	2	Seal-Oil	46	104-1646	1	Bearing-Ball
8	104-1608	4	Bolt-Flange	47	104-1647	1	Bearing-Needle
9	104-1609	2	Plug-Check, Oil	48	104-1648	1	Gear
10	104-1610	2	Gasket	49	104-1649	6	Bolt
11	104-1611	2	Plug-Drain, Oil	50	104-1650	1	Shaft-Axle, LH
12	104-1612	2	Gasket	51	104-1651	1	Shaft-Axle, RH
13	104-1613	1	Plug-Filler, Oil	52	104-1652	4	Bearing-Ball
14	104-1614	1	Case-Complete, RH	53	104-1653	1	Case-Axle, LH
17	104-1617	1	Fork-Governor	54	104-1654	1	Case-Axle, RH
18	104-1618	1	Stopper	55	104-1655	4	Ring-Snap
19	104-1619	4	Screw And Washer ASM	56	104-1656	2	Nut-Castle
20	104-7002	1	Shaft-Input, Complete	57	104-1657	2	Ring-Snap
21	104-1621	1	Base-Governor	58	104-6870	1	Shaft-Shift, Complete
22	104-1622	1	Pin-Lock	59	104-1659	2	Knock-Pipe
23	104-1623	1	Unit-Plate, Governor	60	104-1660	1	Ball-Steel
24	104-1624	1	Bearing-Ball	61	104-1661	1	Spring
25	104-1625	1	Sleeve-Governor	62	104-1662	1	Gasket
26	104-1626	2	Bearing-Ball	63	104-1663	1	Bolt
27	104-1627	1	Spacer	64	104-1664	1	Gasket
28	104-1628	1	Gear	65	104-1665	6	Bolt-Flange
29	104-1629	1	Bracket-Wire, Change	66	104-1666	4	Bolt-Flange
30	104-1630	1	Clutch-Pin	69	104-6867	2	Collar
31	104-1631	1	Shaft-Center	70	33004-00	10	Nut-HF
32	104-1632	1	Gear	71	104-1671	2	Bracket-Axle
33	104-1633	2	Collar	72	104-1672	1	Nut-Lock
34	104-1634	1	Gear	73	104-1673	2	Washer-Spring
35	104-1635	6	Bolt-Flange	74	104-1674	2	Washer
36	104-1636	1	Bearing-Ball	75	104-1675	2	Hub
37	104-1637	1	Bearing-Ball	76	104-6860	1	Lever-Select
38	104-1638	2	Spacer	78	104-8649	10	Stud
39	104-1639	1	Gear				

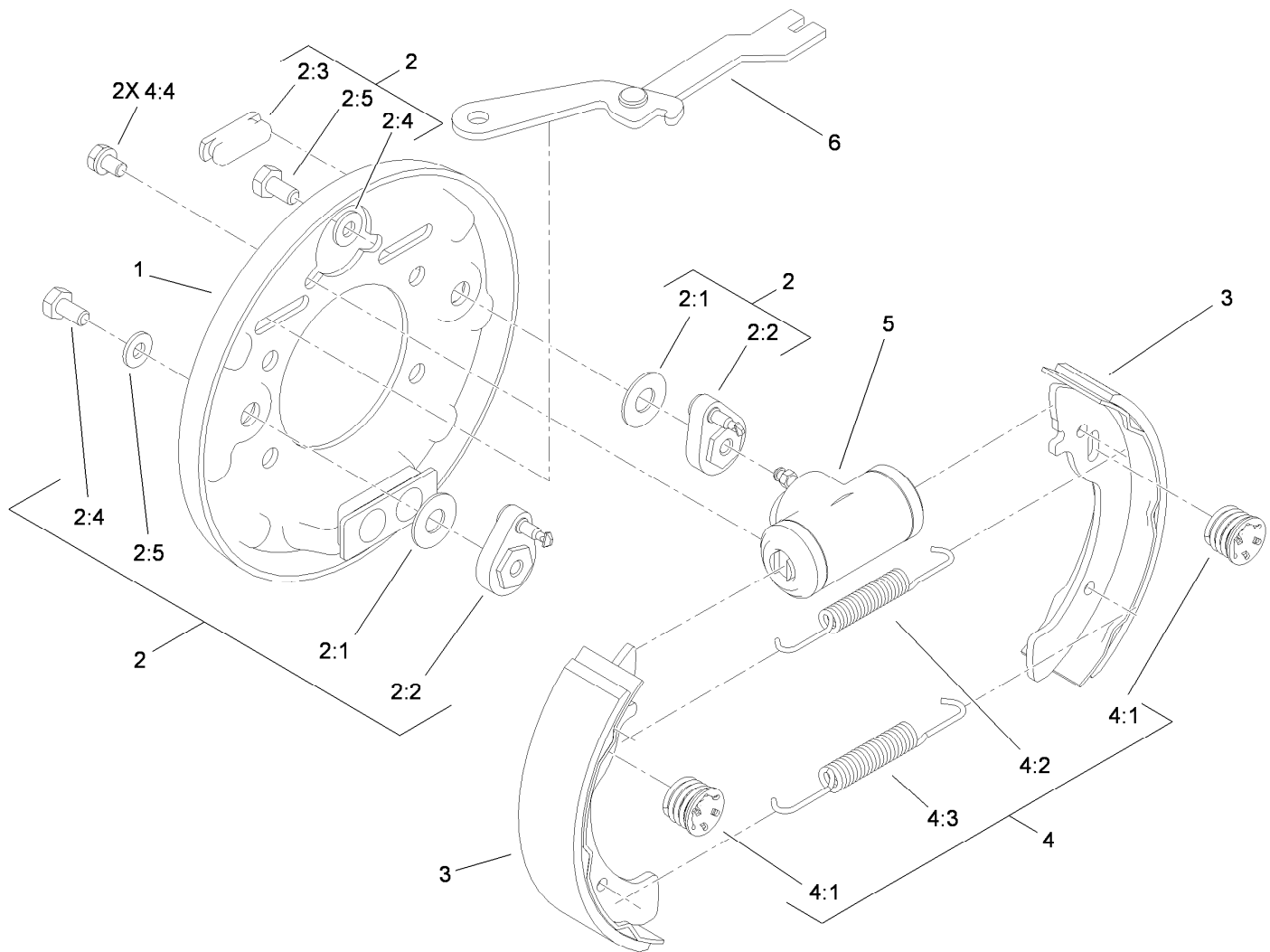

LH Rear Brake Assembly No. 114-8332

Ref.	Part Number	Qty.	Description
1	100-8586	1	Backing Plate ASM
2	104-6820	1	Adjuster Kit
2:1	100-8585	2	Washer-Bellville
2:2	100-8588	2	Adjuster Lever ASM
2:3	100-8584	2	Cover-Dust
2:4		2	Washer ●
2:5		2	Bolt ●
3	104-6818	4	Shoe And Lining Kit
4	104-6819	1	Hardware Kit
4:1	100-8583	2	Shoe Hold Down Spring ASM
4:2	100-8581	2	Spring-Upper
4:3	100-8582	2	Spring-Lower
4:4		2	Bolt And Washer ●
5	114-8333	1	Wheel Cylinder ASM
6	104-6825	1	LH Park Brake Lever ASM

● Not serviced separately

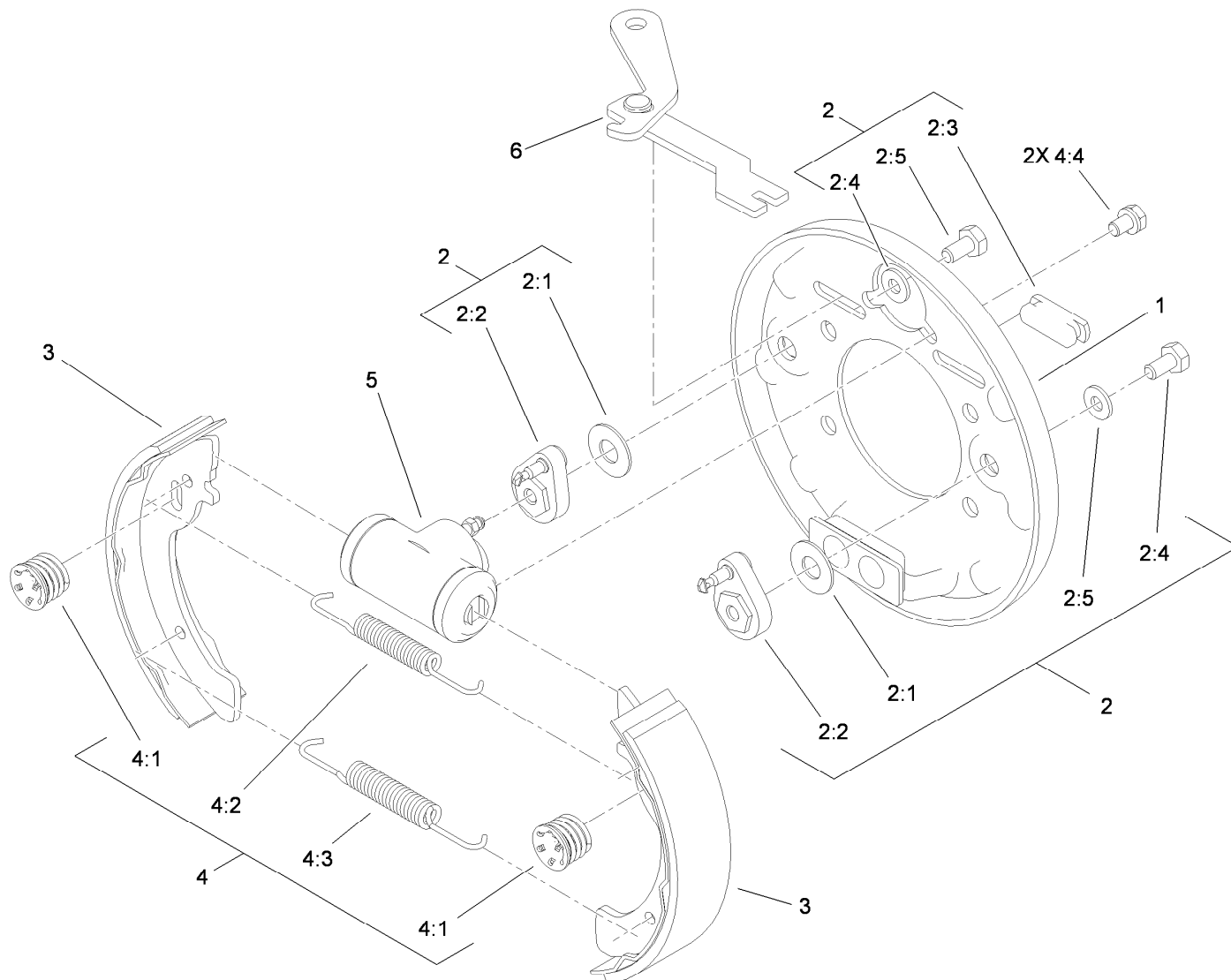

RH Rear Brake Assembly No. 114-8331

Ref.	Part Number	Qty.	Description
1	100-8586	1	Backing Plate ASM
2	104-6820	1	Adjuster Kit
2:1	100-8585	2	Washer-Bellville
2:2	100-8588	2	Adjuster Lever ASM
2:3	100-8584	2	Cover-Dust
2:4		2	Washer ●
2:5		2	Bolt ●
3	104-6818	4	Shoe And Lining Kit
4	104-6819	1	Hardware Kit
4:1	100-8583	2	Shoe Hold Down Spring ASM
4:2	100-8581	2	Spring-Upper
4:3	100-8582	2	Spring-Lower
4:4		2	Bolt And Washer ●
5	114-8333	1	Wheel Cylinder ASM
6	104-6826	1	RH Park Brake Lever ASM

● Not serviced separately

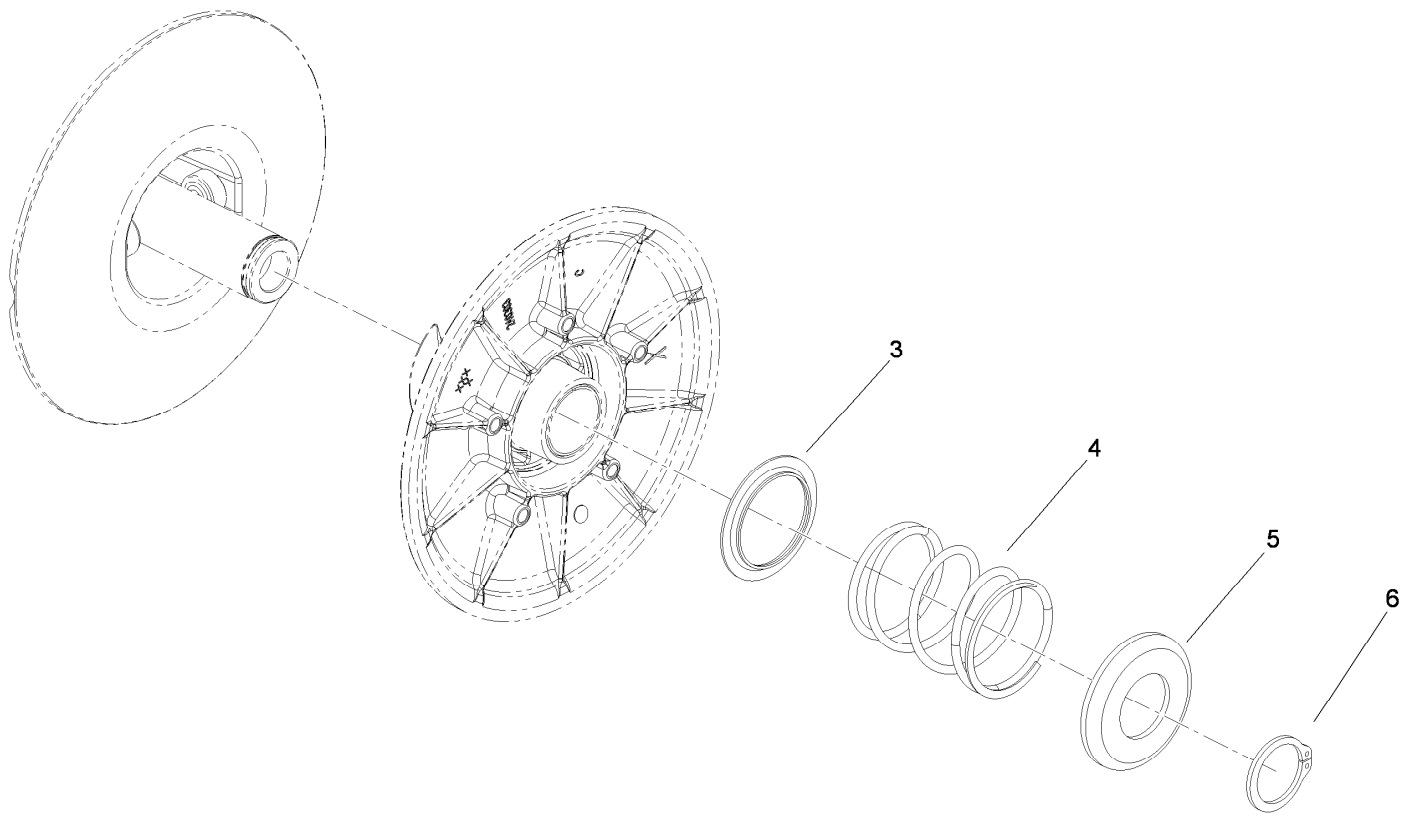

Secondary Clutch Assembly No. 119-0803

<i>Ref.</i>	<i>Part Number</i>	<i>Qty.</i>	<i>Description</i>
3	119-0809	1	Cup-Spring Retainer, Inner
4	119-0808	1	Spring-Secondary (Black/Blue)
5	119-0810	1	Cup-Spring Retainer, Outer
6	119-0811	1	Ring-Retaining

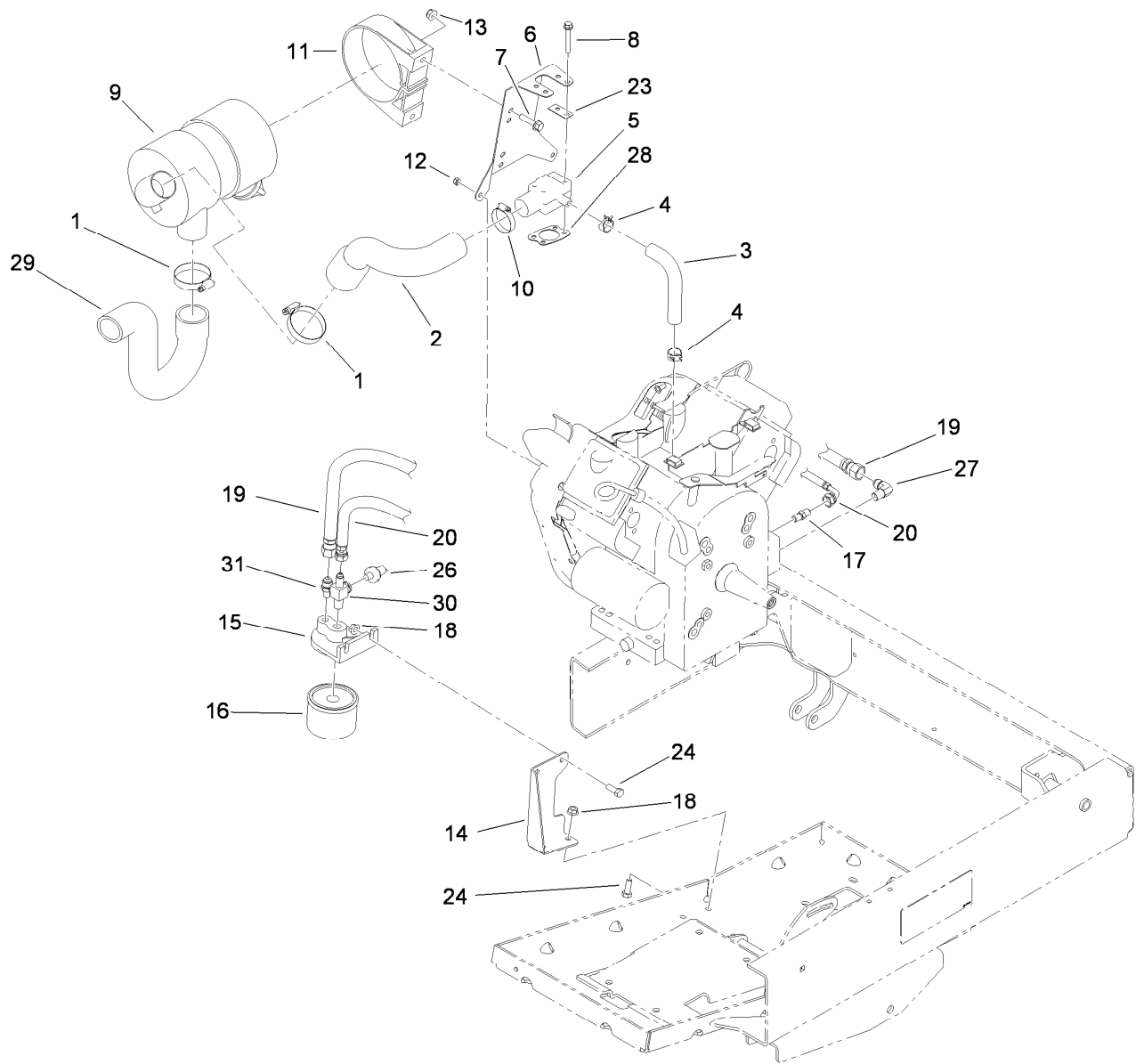

Oil Filter and Air Cleaner Assembly

<i>Ref.</i>	<i>Part Number</i>	<i>Qty.</i>	<i>Description</i>	<i>Ref.</i>	<i>Part Number</i>	<i>Qty.</i>	<i>Description</i>
1	2412-130	2	Clamp-Hose	15	115-2314	1	Adapter-Filter, Oil
2	112-3227	1	Hose-Intake	16	107-7817	1	Filter-Oil
3	112-6461	1	Hose-Adapter, Carboretor	17	112-3282	1	Fitting-Straight
4	2412-143	2	Clamp-Hose	18	32128-20	4	Nut-HF
5	108-2829	1	Adaptor-Carburetor	19	119-0831	1	HYD Hose ASM
6	119-0862-03	1	Bracket-Cleaner, Air	20	119-0832	1	HYD Hose ASM
7	3234-36	2	Screw-HHF	23	108-8427	2	Gasket-Carburetor
8	33103-045	4	Screw-HHF	24	110-5053	4	Screw-Flange
9	99-7120	1	Air Cleaner ASM	26	115-2316	1	Switch-Pressure
10	2412-3	1	Clamp-Hose	27	115-2317	1	Fitting-Elbow
11	95-5806	1	Bracket-Mounting	28	110-8158	1	Gasket-Adaptor
12	33023-00	2	Nut-Lock	29	115-7623	1	Hose-Intake
13	104-8300	2	Nut-Flange, NI	30	119-0826	1	Fitting-Tee
14	112-3240-03	1	Bracket-Filter, Oil	31	119-0833	1	Fitting-Straight

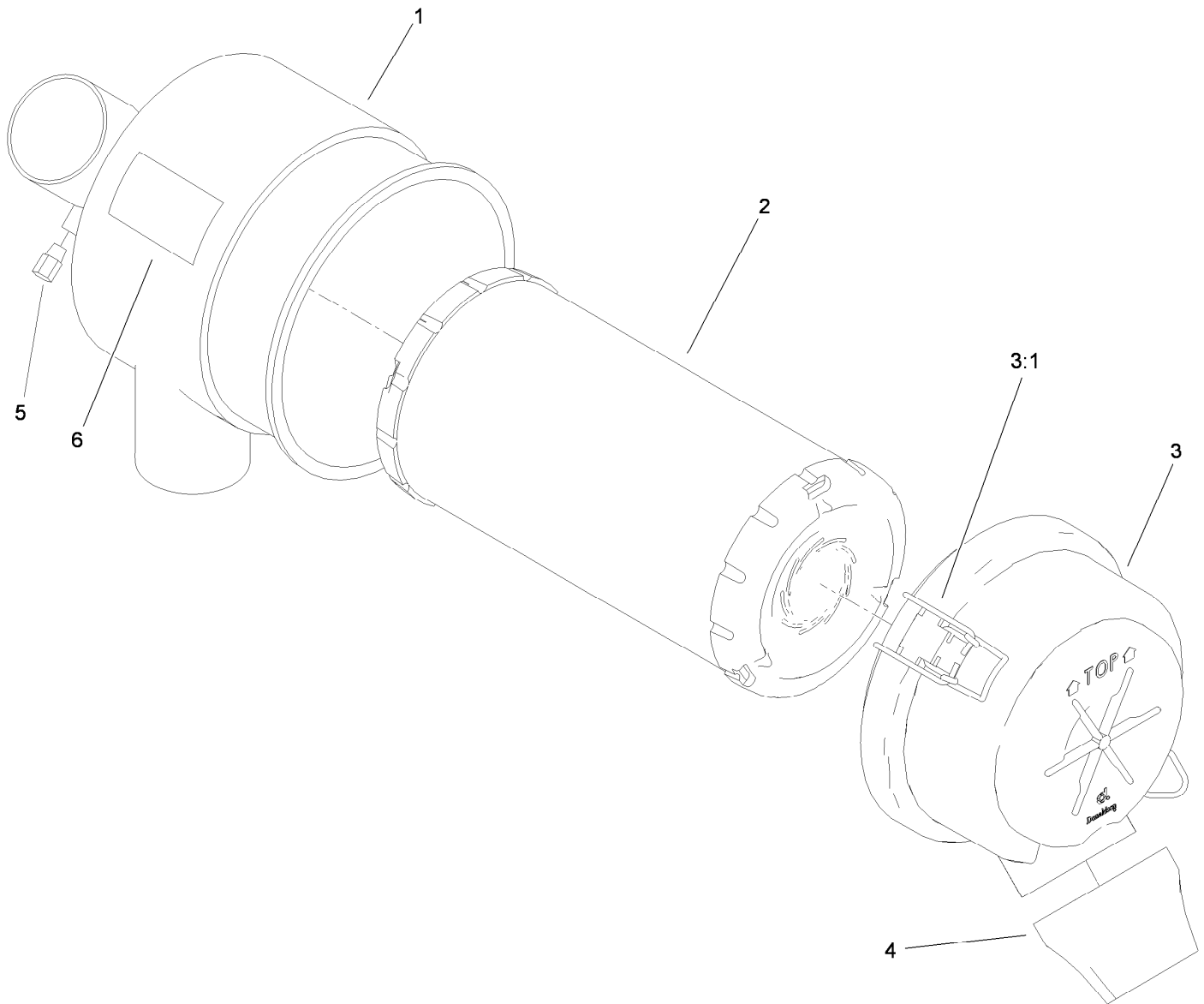

Air Cleaner Assembly No. 99-7120

Ref.	Part Number	Qty.	Description
1		1	Body ●
2	108-3811	1	Filter-Air
3	94-3652	1	Cover ASM
3:1	1-643283	2	Latch-Cleaner, Air
4	87-9400	1	Valve-Vacuator
5		1	Plug ●
6		1	Marking ●

● Not serviced separately

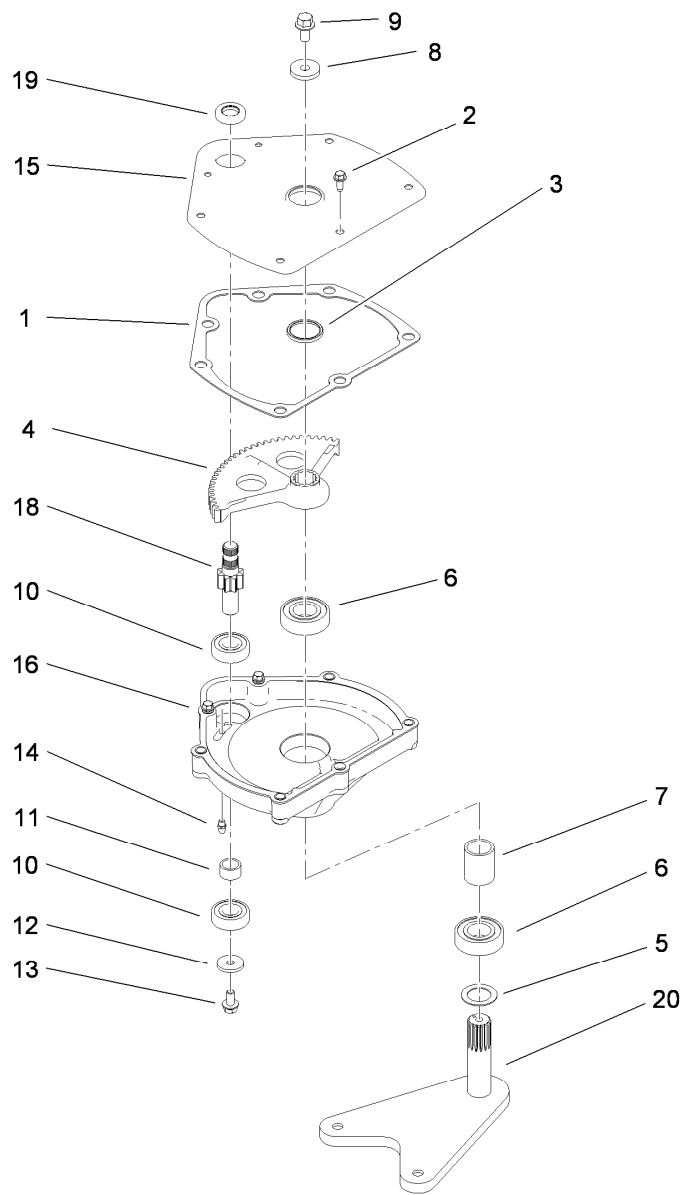

Steering Box Assembly No. 112-3130

<i>Ref.</i>	<i>Part Number</i>	<i>Qty.</i>	<i>Description</i>	<i>Ref.</i>	<i>Part Number</i>	<i>Qty.</i>	<i>Description</i>
1	94-2135	1	Gasket	11	94-2217	1	Spacer-Shaft, Input
2	32144-10	3	Screw-HWH	12	1-613235	1	Washer
3	103118	1	Seal	13	98-3498	1	Screw-HH
4	99-7843	1	Sector-Gear	14	302-5	1	Fitting-Grease
5	3256-42	1	Washer-Flat	15	112-2918-03	1	Cover-Housing, Steering
6	251-82	2	Bearing-Ball	16	114-8309	1	Housing-Steering
7	112-2917	1	Spacer	18	115-7726	1	Gear-Pinion
8	104-6563	1	Washer-Stepped	19	99-7657	1	Seal-Oil
9	104-7156	1	Screw-HHF	20	112-3096-03	1	Pitman Arm ASM
10	38-7820	2	Bearing-Ball				

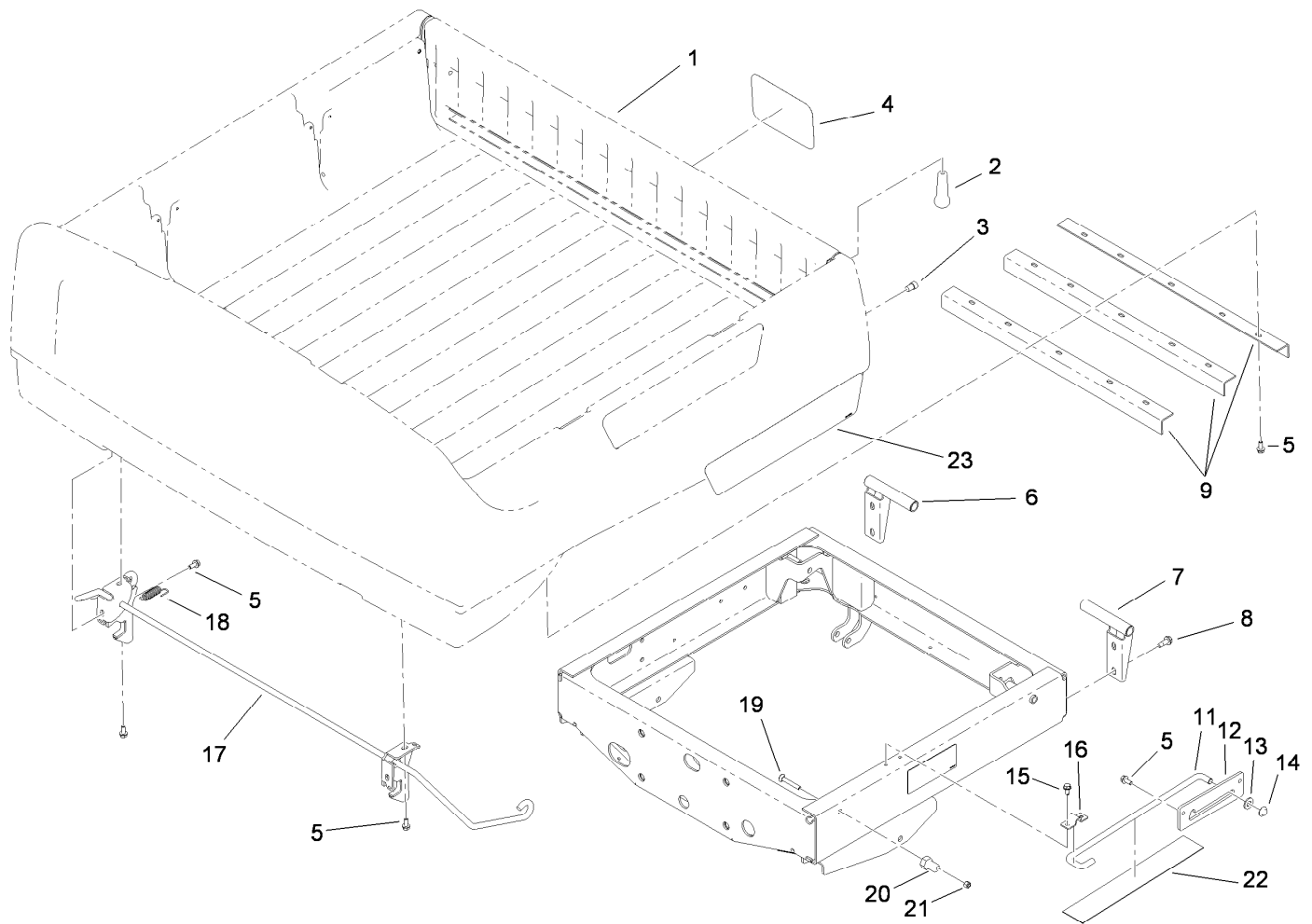

Box and Tailgate Installation Assembly

<i>Ref.</i>	<i>Part Number</i>	<i>Qty.</i>	<i>Description</i>	<i>Ref.</i>	<i>Part Number</i>	<i>Qty.</i>	<i>Description</i>
1		1	Box And Tailgate ASM ●	13	3256-26	1	Washer-Flat
2	99-7984	2	Knob-Soft Grip, Push-On	14	32112-14	1	Nut-Push
3	115-7986	2	Bumper-Rubber	15	32104-32	2	Screw-HWH
4	104-7213	1	Decal	16	99-7896	1	Bracket-U, Prop Rod
5	3234-5	19	Screw-HHF	17	115-2385	1	Rod-Latch
6	99-7309-03	1	RH Pivot Bracket ASM	18	5-7290	2	Spring-Tension
7	99-7308-03	1	LH Pivot Bracket ASM	19	3230-7	2	Screw-CARR
8	105-6245	4	Screw-Tapping	20	104-7248	2	Pin-Latch
9	99-7864-03	3	Brace-Box	21	3296-29	2	Nut-Lock, NI
11	99-7895	1	Rod-Prop	22	104-6859	1	Shield-Heat
12	99-7894	1	Bracket-Rod, Prop	23	115-2414	2	Decal

● Not serviced separately

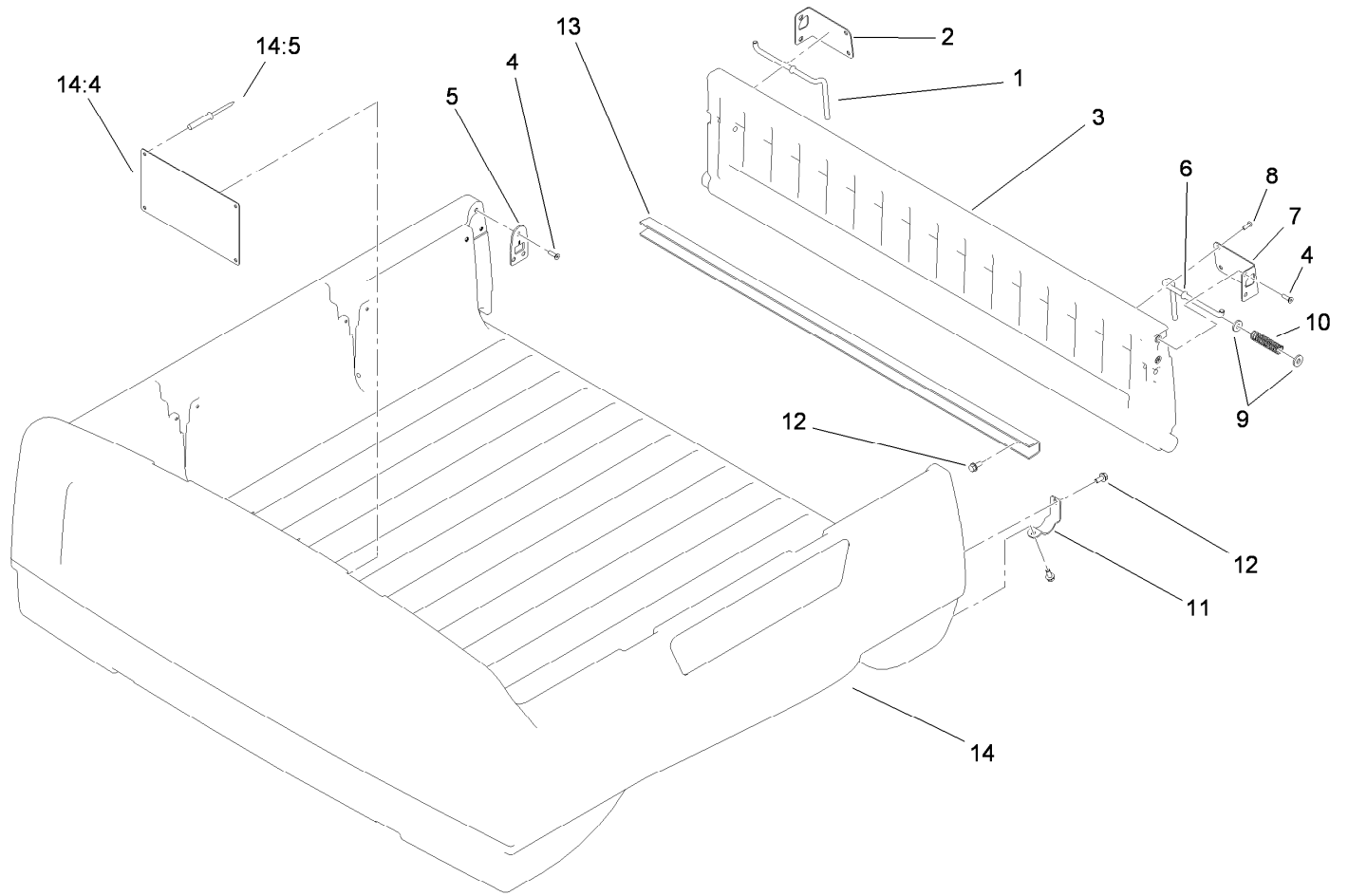

Box and Tailgate Assembly

<i>Ref.</i>	<i>Part Number</i>	<i>Qty.</i>	<i>Description</i>	<i>Ref.</i>	<i>Part Number</i>	<i>Qty.</i>	<i>Description</i>
1	99-7860	1	Rod-Latch, Right	9	99-7861	4	Washer-Latch
2	99-7858	1	Bracket-Tailgate Latch, Right	10	61-8880	2	Spring
3	115-7640	1	Tailgate ASM	11	99-7286	2	Bracket-Pivot, Tailgate
4	99-7334	10	Screw	12	3234-5	10	Screw-HHF
5	114-2749	2	Plate-Striker	13	99-7867	1	Channel-Tailgate
6	99-7859	1	Rod-Latch, Left	14	115-7638	1	Box ASM
7	99-7857	1	Bracket-Tailgate Latch, Left	14:4	99-7954	1	Decal-No Riders
8	99-7335	4	Screw	14:5	3290-415	4	Rivet

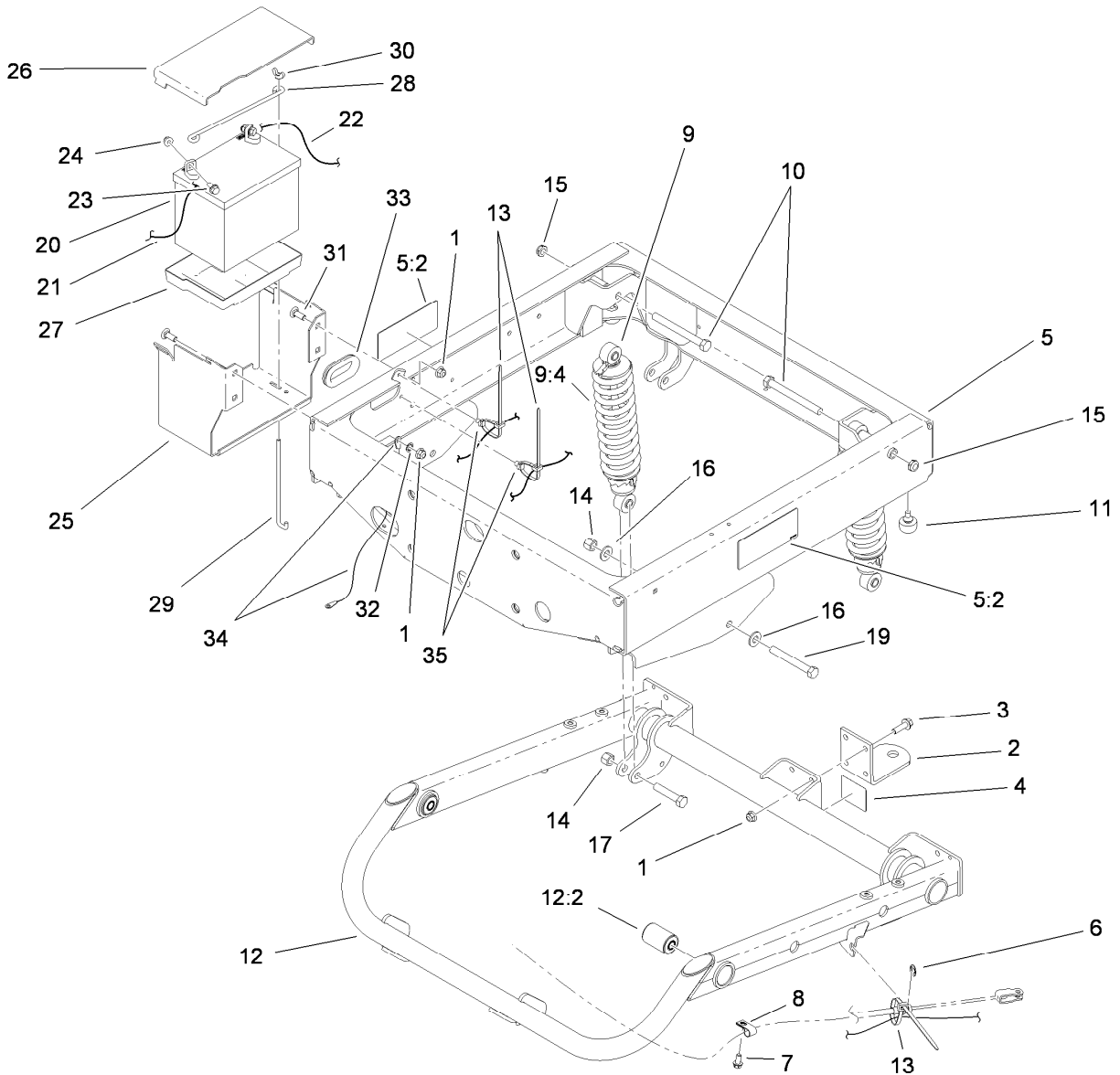

Frame Assembly

Ref.	Part Number	Qty.	Description	Ref.	Part Number	Qty.	Description
1	104-8301	8	Nut-Flange, NI	16	87-7270	4	Washer-Thrust
2	99-7654-03	1	Hitch-Duty, Light	17	325-10	2	Screw-HH
3	3234-24	4	Screw-HHF	19	325-17	2	Screw-HH
4	99-7350	1	Decal-Rating, Hitch (Light Duty)	20	104-8162	1	Battery
5	114-8307	1	Rear Frame Service ASM	21	115-8107	1	Cable-Battery, Negative
5:2	99-7345	2	Decal-Warning	22	114-9404	1	Cable-Battery, Positive
6	32120-47	2	Ring-Retaining, External	23	3234-5	2	Screw-HHF
7	32144-4	2	Screw-HWH	24	104-8300	2	Nut-Flange, NI
8	2412-89	2	Clamp	25	115-2302-03	1	Base-Battery
9	112-3168	2	Rear Shock/Spring ASM	26	115-2394	1	Cover-Battery
9:4	112-3386	1	Spring	27	106948	1	Tray-Battery
10	325-19	2	Screw-HH	28	100-6434	1	Rod-Hold Down, Battery
11	87-2440	2	Bumper-Rubber	29	100-6435	2	Post-Battery
12	115-7614	1	Swing Arm ASM	30	32103-22	2	Nut-Wing
12:2	112-3377	2	Bushing-Arm, Control	31	3231-22	4	Screw-CARR
13	3290-378	4	Tie-Cable	32	3254-6	1	Washer-Lock, Internal
14	3296-23	4	Nut-Lock, NI	33	240-12	1	Grommet
15	3296-45	2	Nut-Lock, NI	34	115-8108	1	Cable-Battery, Negative
				35	32180-030	2	Clip-Harness

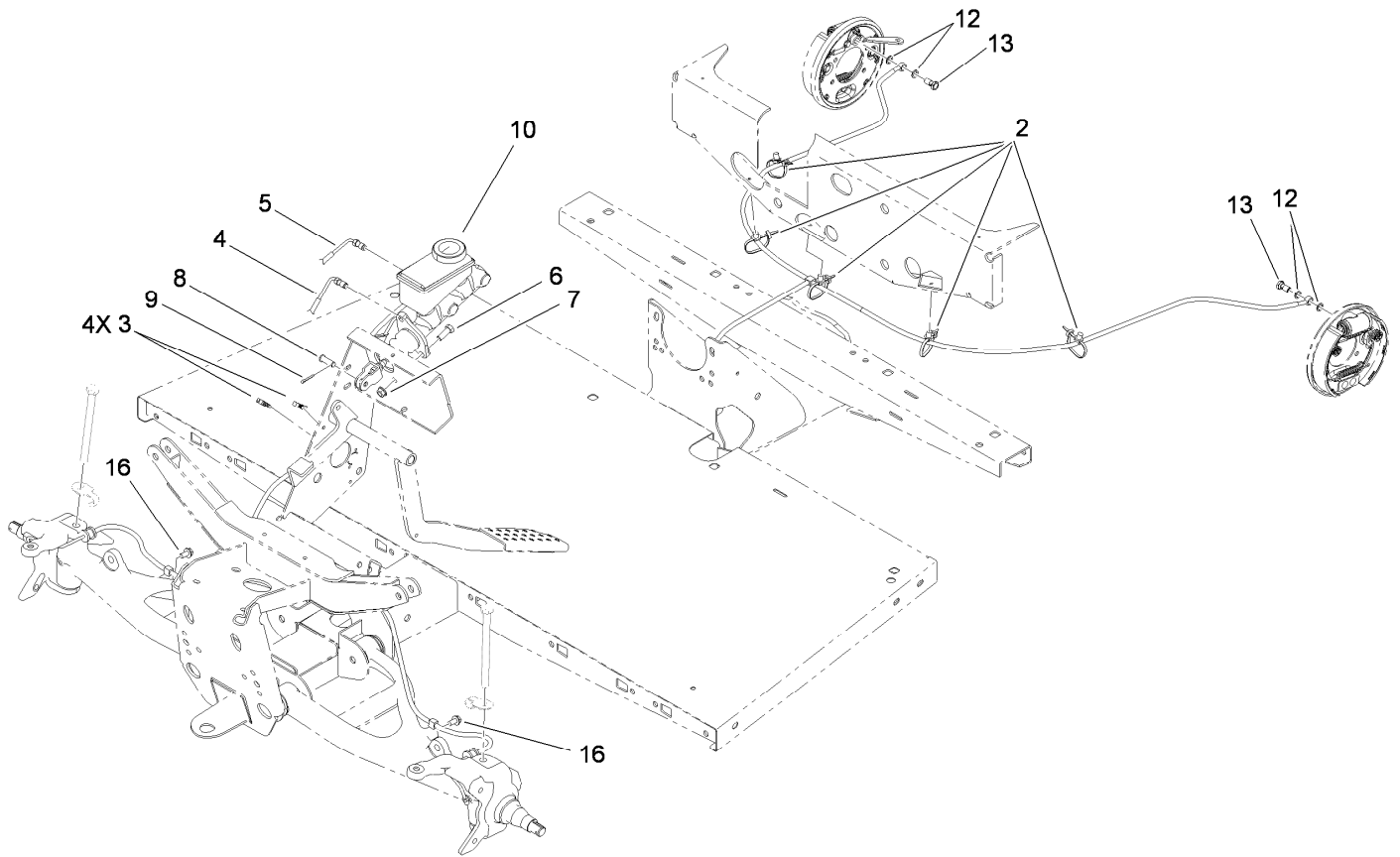

Master Cylinder and Brake Line Assembly

Ref.	Part Number	Qty.	Description
2	32180-030	5	Clip-Harness
3	114-8324	4	Clip-Line, Brake
4	112-2925	1	Front Brake Line ASM
5	112-2926	1	Rear Brake Line ASM
6	323-6	2	Screw-HH
7	3290-357	2	Nut-HHF, Whiz
8	283-2	1	Pin-Clevis
9	3272-10	1	Pin-Cotter
10	104-6782	1	Cylinder-Master
12	115-2341	4	Washer-Banjo
13	115-2340	2	Bolt-Banjo
16	32104-82	2	Screw-HHF

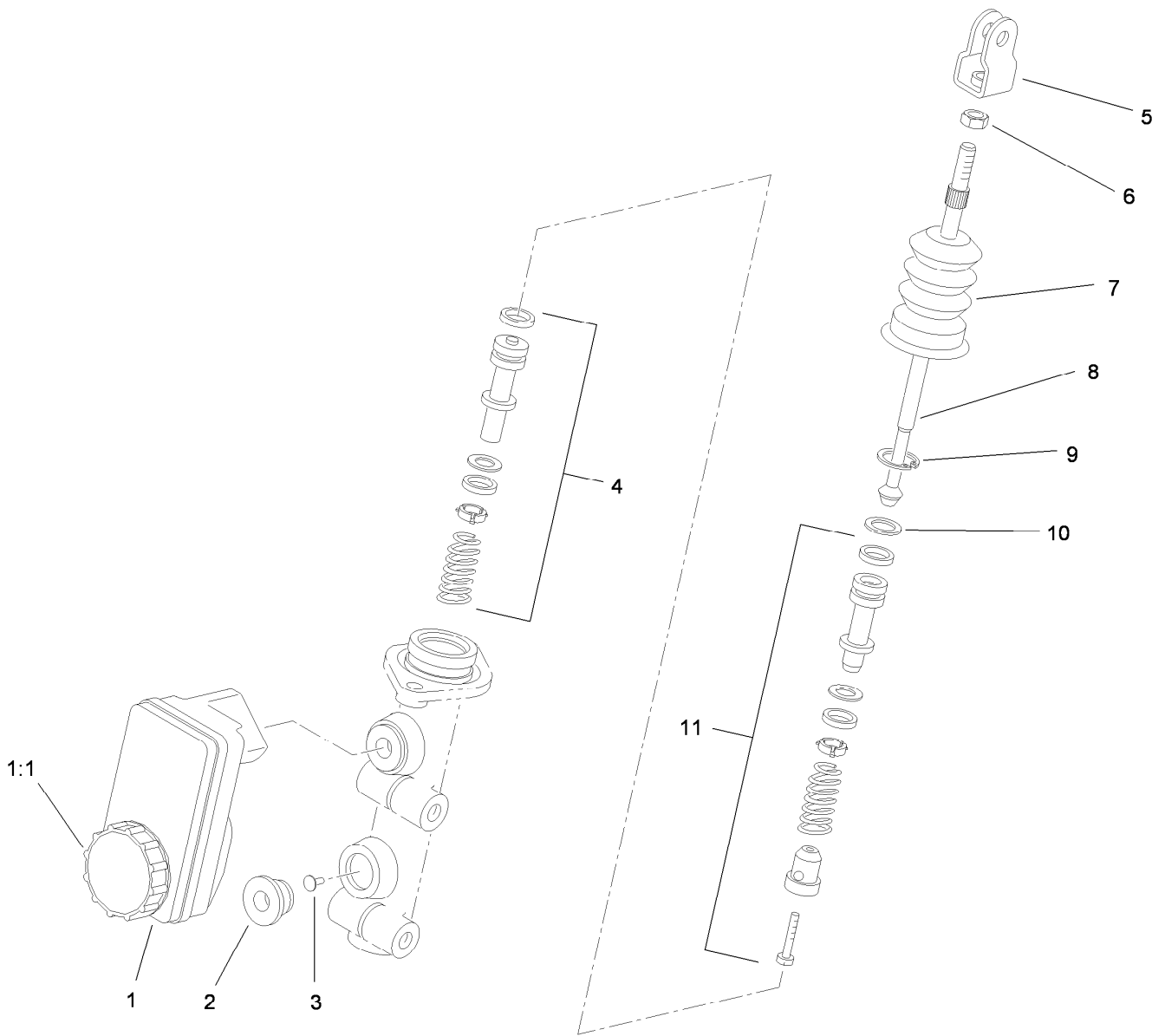

Master Cylinder Assembly No. 104-6782

Ref.	Part Number	Qty.	Description
1	104-6845	1	Reservoir ASM
1:1	92-4112	1	Cap ASM
2	93-8971	2	Seal-Port, Flange
3	92-4103	1	Pin-Stop
4	92-4102	1	Secondary Piston ASM
5	92-4110	1	Clevis
6	21-0360	1	Nut-Hex
7	94-5209	1	Cover-Dust
8	94-5210	1	Rod-Push
9	92-4109	1	Ring-Snap
10	92-4108	1	Retainer-Washer
11	92-4101	1	Primary Piston ASM

Attachments and Accessories

For 07273TC Workman MDX Utility Vehicle

Product Name	Model/Part
Roll-Over Protection System	07276
Receiver Hitch Kit	07278
Stake Side Kit	07290
Portable Refreshment Center	07298
Canopy Kit	07324
Solid Windshield Kit	07325
Folding Windshield Kit	07326
Snow Plow	07327
Hard Cab	07328
Heavy-Duty Bumper Kit	07329
Rear Lift Kit	07334
Electric Bed Lift Kit	07335
Vinyl Enclosure	07337
Heavy-Duty Brush Guard and Bumper Kit	07338
Sliding Window Door Kit	07352
Fixed Window Door Kit	07353
Wheel-5 Bolt	104-6889
Tire-AT 489, 24x10.5-10	104-7061
Tire-AT 489, 22x9.5-10	104-7062
Brake and Signal Light Kit	115-7749
Lift Wire Harness Kit	115-7823
Backup Alarm Kit	115-7824
Replacement Front Spring Kit	117-4847
Tire And Wheel Asm	119-0751

Notes:

Notes:



Count on it.