



# Hand Spray Gun Kit

## Multi-Pro® 5800 Turf Sprayer

Model No. 41605—Serial No. 311000001 and Up

### Installation Instructions

The hand spray gun kit is an attachment for a turf spray application vehicle and is intended to be used by professional, hired operators in commercial applications. It is primarily designed for spraying on well-maintained lawns in parks, golf courses, sports fields, and on commercial grounds.

This product complies with all relevant European directives. For details, please see the separate product-specific Declaration of Conformity (DOC) sheet.

Read this manual carefully to learn how to operate and maintain your product properly. The information in this manual can help you and others avoid injury and product damage. Although Toro designs and produces safe products, you are responsible for operating the product properly and safely.

You may contact Toro directly at [www.Toro.com](http://www.Toro.com) for product and accessory information, help finding a dealer, or to register your product.

Whenever you need service, genuine Toro parts, or additional information, contact an Authorized Service Dealer or Toro Customer Service and have the model and serial numbers of your product ready. Figure 1 illustrates the location of the model and serial numbers on the product.

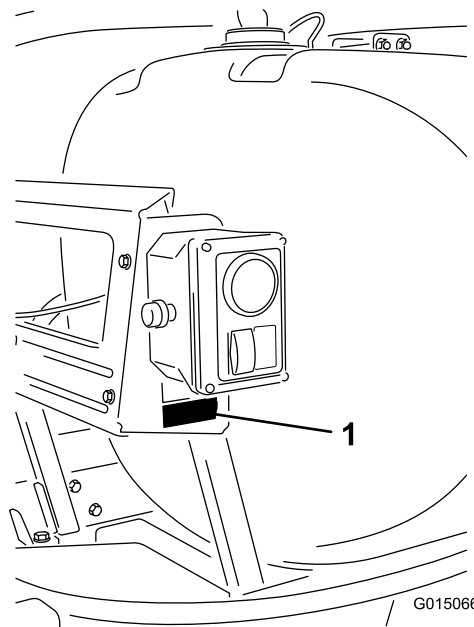

**Figure 1**

1. Model and serial number plate

<b>Model No.</b> _____
<b>Serial No.</b> _____

# Safety

This manual identifies potential hazards and has safety messages identified by the safety alert symbol (Figure 2), which signals a hazard that may cause serious injury or death if you do not follow the recommended precautions.



Figure 2

1. Safety alert symbol

---

This manual uses 2 other words to highlight information. **Important** calls attention to special mechanical information and **Note** emphasizes general information worthy of special attention.

Read also the safety and operation instructions in the vehicle *Operator's Manual*.

- Do not aim the hand sprayer at any person or animal. Fluids under high pressure can penetrate skin and cause severe injury, possibly resulting in amputation

or death. Hot liquids and chemicals can also cause burns or injury. If any part of the body comes in contact with the spray stream, immediately consult a physician familiar with injected fluid injuries.

- Do not place your hand or any other part of your body in front of the spray nozzle.
- Do not leave the equipment under pressure when you are not present.
- Do not use the hand sprayer if the hose, trigger lock, nozzle, or any other part is damaged or missing.
- Do not use the hand sprayer if there are any leaks in any hoses, fittings, or other components.
- Do not spray near power lines; the spray stream could contact the power lines and give you a potentially fatal electrical shock.
- Do not drive while spraying with a hand sprayer.
- Wear rubber gloves, safety goggles, and a full-body protective suit when spraying chemicals with the hand sprayer.
- Lightning can cause severe injury or death. If lightning is seen or thunder is heard in the area, do not operate the machine; seek shelter.

## Safety and Instructional Decals



Safety decals and instructions are easily visible to the operator and are located near any area of potential danger. Replace any decal that is damaged or lost.

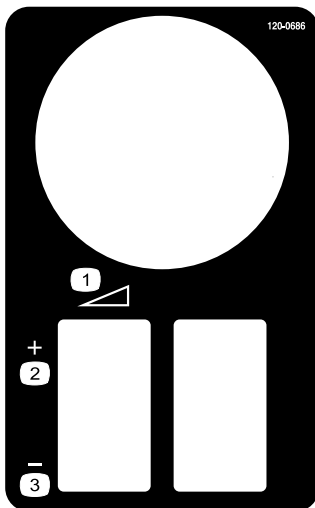

120-0686

1. Continuous variable setting
2. Increase
3. Decrease

# Installation

## Loose Parts

Use the chart below to verify that all parts have been shipped.

Procedure	Description	Qty.	Use
<b>1</b>	No parts required	–	Prepare the machine.
<b>2</b>	Hose hook Washer (3/8 inch) Locknut (5/16 inch) Carriage bolt	2 2 2 2	Installing the hose hooks.
<b>3</b>	Manual valve assembly Threaded rod Locknut Washer Jam nut	1 4 8 6 8	Install the valve assembly.
<b>4</b>	Control box and bracket assembly Bolt (1/4 x 5/8 inch) Locknut (1/4 inch)	1 3 3	Install the control box.
<b>5</b>	Hose Hose clamp	1 2	Install the supply hose.
<b>6</b>	Long hose with fitting Spray gun Hose clamp, small	1 1 1	Connect the spray hose.

**Note:** Determine the left and right sides of the machine from the normal operating position.

**Note:** Thread sealing tape is used in the installation of this kit.

# 1

## Preparing the Machine

### No Parts Required

#### Procedure

1. Ensure that the machine is empty of all fluids. If chemicals have been used in the machine, flush the system thoroughly with clean water and drain the water; refer to your vehicle *Operator's Manual* for instructions.
2. Disconnect the negative battery terminal from the battery.

# 2

## Installing the Hose Hooks

### Parts needed for this procedure:

2	Hose hook
2	Washer (3/8 inch)
2	Locknut (5/16 inch)
2	Carriage bolt

#### Procedure

1. Loosen the front tank strap on the right hand side (Figure 3).

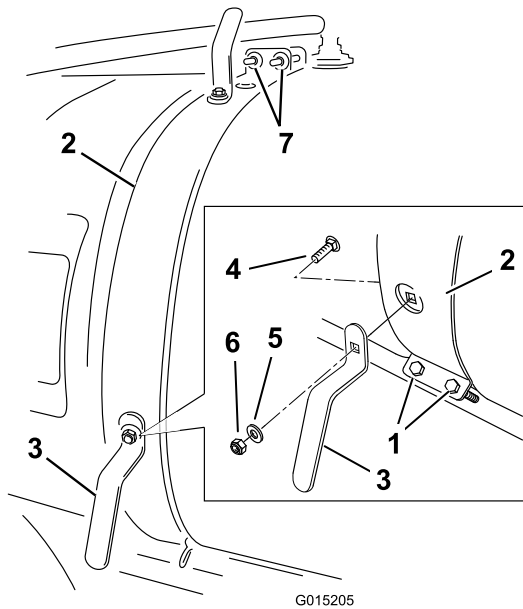

**Figure 3**

1. Tank strap fasteners (older style)
2. Front tank strap
3. Hose hook (2)
4. Carriage bolt (5/16 x 3/4 inch) (2)
5. Washer (3/8 inch)
6. Locknut (5/16 inch)
7. Tank strap fasteners (newer style)

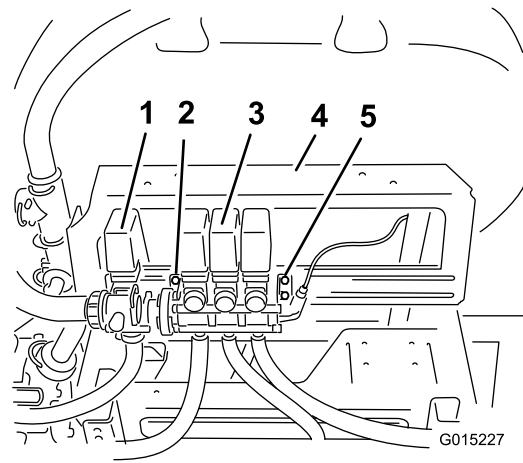

**Figure 4**

1. Agitation valve
2. Left-hand mount bracket
3. Bypass valve assembly
4. Right-hand mount bracket
5. Fasteners (loosen but do not remove)

2. Install the lower hose hook as shown in Figure 3 using a carriage bolt (5/16 x 3/4 inch), a washer (3/8 inch), and a locknut (5/16 inch).
3. Install the upper hose hook as shown in Figure 3 using a carriage bolt (5/16 x 3/4 inch), a washer (3/8 inch), and a locknut (5/16 inch).

# 3

## Installing the Manual Valve

### Parts needed for this procedure:

1	Manual valve assembly
4	Threaded rod
8	Locknut
6	Washer
8	Jam nut

### Procedure

1. Loosen, but do not remove, the bolts that secure the boom valve assembly to the right-hand mount bracket (Figure 4).

2. Remove the long bolts and fasteners that secure the valve assembly (Figure 5).

**Note:** Discard the long bolts, but retain the washers and locknuts.

**Note:** The valve assembly will no longer be anchored to the machine at this point.

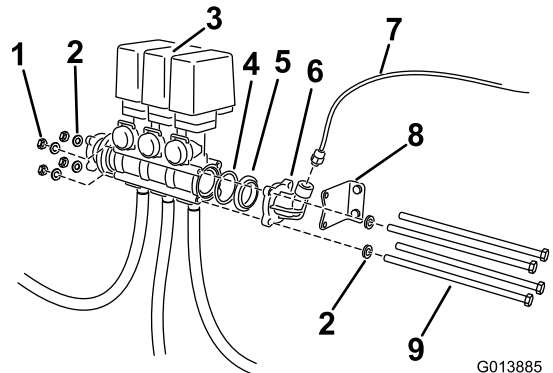

**Figure 5**

1. Locknut
2. Washer
3. Valve assembly
4. O-ring
5. Adapter
6. Elbow cap
7. Red tube
8. Right-hand mount bracket
9. Long bolts, existing

3. Secure the boom valves together with 2 cable ties from loose parts, and remove the right-hand bracket.

**Note:** As an alternative to this step, you may wish to remove the boom hoses from the valves and move the entire assembly to a workbench.

4. Remove the elbow cap and the adapter (Figure 5).

**Note:** Save these parts for installing the manual valve.

5. Move the right-hand mount bracket away from the existing valve assembly.
6. If the existing O-ring is not seated in the open end of the boom valve body, install it now.
7. Install the adapter that you removed in step 4.
8. Insert the threaded rods through the holes in the valve bodies of the boom bypass valves, and for the 2 rods closest to the mounting rail, through the left-hand mount bracket (Figure 4 and Figure 6).

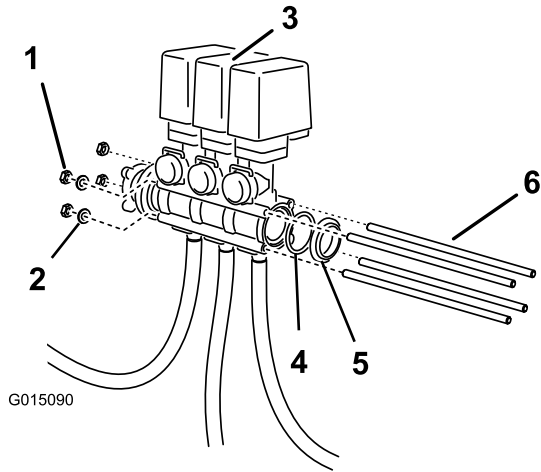

**Figure 6**

- |                   |                     |
|-------------------|---------------------|
| 1. Locknut (4)    | 4. O-ring           |
| 2. Washer (2)     | 5. Adapter          |
| 3. Valve assembly | 6. Threaded rod (4) |

9. Slip washers onto the rods that do not go through the left-hand mount bracket, and thread a locknut on the left-hand end of every rod (Figure 7).

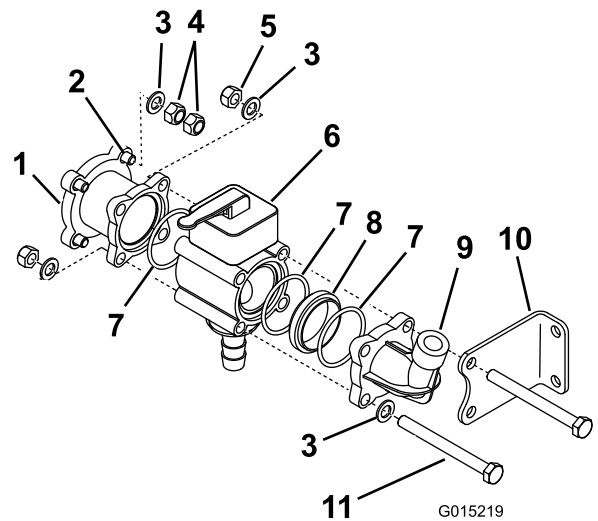

**Figure 7**

- |  |                         |
|--|-------------------------|
| 1. Reducing adapter                      | 7. O-ring               |
| 2. Threaded rod end (the rest not shown) | 8. Adapter              |
| 3. Washer                                | 9. Elbow cap (existing) |
| 4. Jam nuts (8)                          | 10. Mount bracket       |
| 5. Locknut                               | 11. Bolt (4)            |
| 6. Manual valve                          |                         |

10. Install the reducing adapter from the loose parts bag onto the threaded rods (Figure 7).
11. Install a washer and 2 jam nuts on the right-hand end of each of the 4 threaded rods to secure the reducing adapter to the boom bypass valve assembly (Figure 7).
12. Tighten all fasteners securely.
13. Pre-assemble the manual valve manifold assembly using the manual valve, an O-ring, an adapter from loose parts, an O-ring, and the elbow cap that you previously removed (Figure 7).

**Note:** You will need an O-ring from the loose parts bag.

**Note:** Install the elbow that you previously removed with the bend pointing upward.

14. Slip washers and bolts on the 2 front holes (away from the mount bracket) of the pre-assembled manual valve manifold to hold it together (Figure 7).
15. Install the manual valve assembly with 2 of the washers and bolts needed, and install, but do not tighten, a washer and a locknut on the other end of each rod (Figure 7).
16. Position the right-hand mount bracket in place.
17. Insert the 2 bolts through the right-hand mount bracket and the manual valve assembly.
18. Torque all locknuts on the threaded rods to 24 to 30 in-lb (272 to 373 N-cm).

19. Secure the bolts of the right-hand mount bracket to the mounting rail.
20. If the tee fitting is not connected to the elbow cap, install the tee fitting.

**Note:** Position the tee fitting so that the side port faces the tank.

- A. Remove the reducer fitting that secures the red pressure gauge tube to the elbow adapter.
- B. Install the reducer fitting that you removed in the previous step to the top port the tee fitting.
- C. Install the red pressure gauge.

# 4

## Installing the Control Box

### Parts needed for this procedure:

1	Control box and bracket assembly
3	Bolt (1/4 x 5/8 inch)
3	Locknut (1/4 inch)

### Procedure

1. Locate the control box and bracket assembly in loose parts.
2. Install the assembly to the mount bracket using 3 bolts (1/4 x 5/8 inch) and 3 locknuts (1/4 inch) as shown in Figure 8.

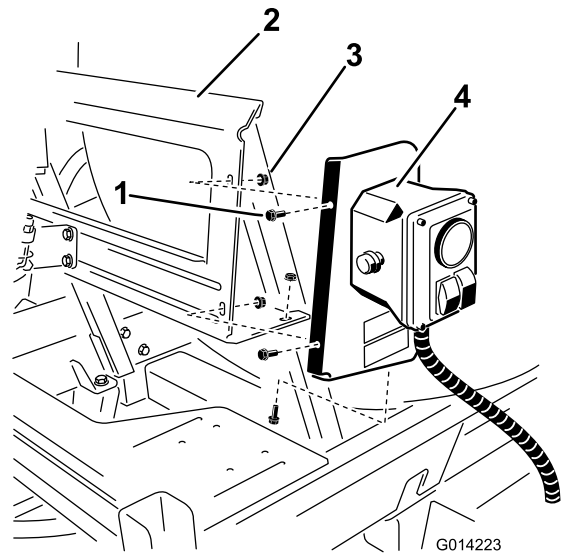

**Figure 8**

1. Bolt (3)
2. Mount bracket
3. Locknut (3)
4. Control box and bracket

3. Locate the red (pressure gauge) tube coming from the back of the control box and install it to the opening in the tee fitting (Figure 9).

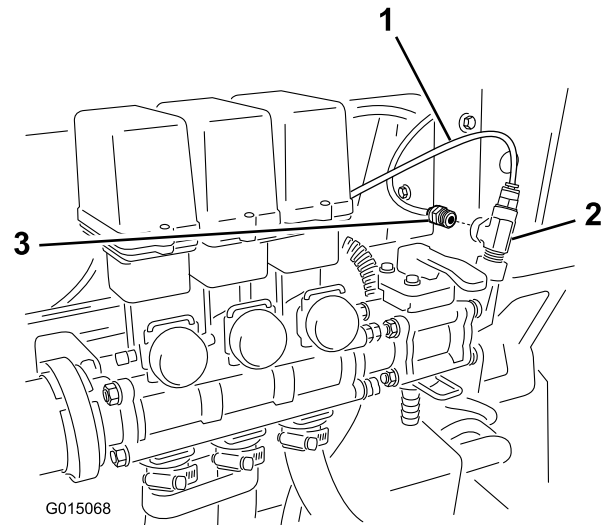

**Figure 9**

1. Pressure gauge tube from control box
2. Tee fitting
3. Reducer fitting

# 5

## Installing the Supply Hose

### Parts needed for this procedure:

1	Hose
2	Hose clamp

### Procedure

1. Slide a hose clamp over the open end of the hose and install the hose over the exposed barb in the manual valve.

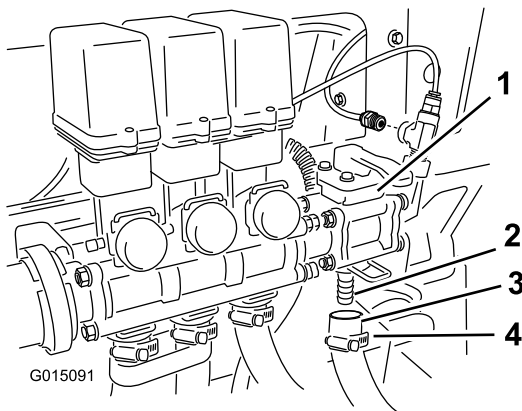

Figure 10

1. Manual valve
2. Barb
3. Hose
4. Hose clamp

2. Move the hose clamp over the barb and tighten to secure the hose to the valve assembly.

# 6

## Connecting the Spray Hose

### Parts needed for this procedure:

1	Long hose with fitting
1	Spray gun
1	Hose clamp, small

### Procedure

1. Connect the free end of the long hose to the fitting on the spray gun (Figure 11).

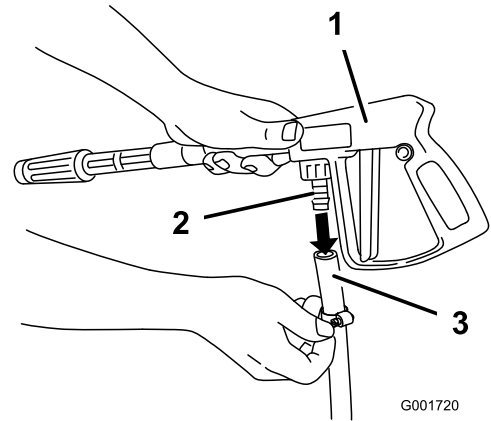

Figure 11

2. Secure the end of the hose with a small hose clamp.
3. Wrap the hose around the hooks of the tank and secure the gun as shown in Figure 12.

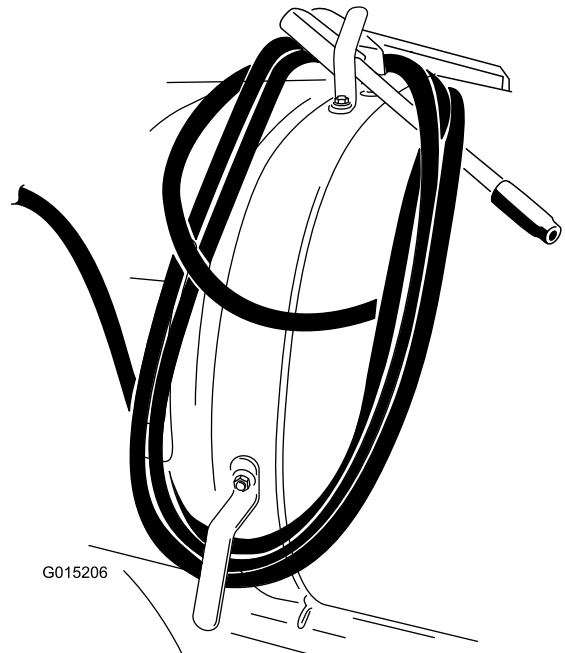

Figure 12

4. Connect the negative battery wire to the battery.

# 7

## Installing the Electrical Harness

### No Parts Required

### Procedure

Locate the electrical harness coming from the control box, and connect the harness to the harness plug labeled “hose reel.”

## Operation

### ⚠ WARNING

Fluid under pressure can penetrate skin and cause injury.

- Keep your body and hands away from nozzles that eject high pressure fluid.
- Do not aim the sprayer at any person or animal.
- Ensure that all fluid hoses and lines are in good condition and all connections and fittings are tight before applying pressure to the system.
- Use cardboard or paper to find leaks.
- Safely relieve all pressure in the system before performing any work on it.
- Get immediate medical help if fluid is injected into the skin.
- Hot liquids and chemicals can cause burns or other harm.

## Turf Care Precautions while Operating in Stationary Modes

**Important:** Under some conditions, heat from the engine, radiator, and muffler can potentially damage the grass when operating the sprayer in a stationary mode. Stationary modes include tank agitation, hand spraying, or using a walking boom.

Use the following precautions:

- **Avoid** stationary spraying when conditions are very hot and/or dry, as turf can be more stressed during these periods.
- **Avoid** parking on the turf while stationary spraying. Park on a cart path whenever possible.
- **Minimize** the amount of time the machine is left running over any particular area of turf. Both time and temperature affect how much the grass may be damaged.
- **Set the engine speed as low as possible** to achieve the desired pressure and flow. This will minimize the heat generated and the air velocity from the cooling fan.
- **Allow heat to escape** upward from the engine compartment by raising the engine guard/seat assemblies during stationary operation rather than being forced out under the vehicle. Refer to your *Operator's Manual* for more information on raising the seat assemblies.

**Note:** Use a heat shield blanket underneath the vehicle during stationary operation if you desire additional heat

protection. Contact an Authorized Toro Dealer to obtain a Toro heat shield blanket kit for turf sprayers.

## Switching from Boom Spray Mode to Hand Spray Mode

1. Stop the machine and set the parking brake.

### **▲ WARNING**

**Driving while using the hand sprayer can cause loss of control, resulting in injury or death. Do not operate the hand sprayer while driving.**

2. Set the throttle 25 percent of the way toward the Fast position.
3. Ensure that the pump switch is on and the Pro Control™ (if applicable) is set in the manual position.
4. Ensure that the trigger lock on the spray gun is locked.
5. Lift up the lever.

**Note:** The level of performance experienced by the operator is dependant upon accessory pressure required, accessory speed and other adjustable variables. For most reasonable settings, attachments will meet and exceed operator requirements. Please consult your nozzle selection guide for further information.

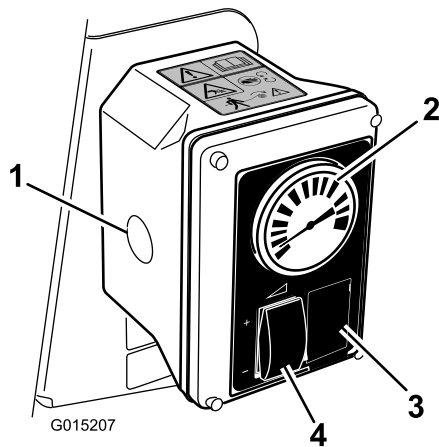

**Figure 13**

- |                   |                        |
|-------------------|------------------------|
| 1. Plug           | 3. Plug                |
| 2. Pressure gauge | 4. Rate control switch |

6. Adjust the rate control switch and the throttle to increase or decrease the pressure, as read on the pressure gauge, to the desired setting (Figure 13).

**Note:** Use the lowest throttle setting possible to achieve the desired pressure. This can be achieved

by setting the pressure to maximum with the rate control switch and then adjusting the throttle speed until the desired pressure is obtained.

**Note:** The maximum recommended operating pressure of the hand spray gun kit is 150 psi.

## Spraying with the Hand Sprayer

1. Remove the desired amount of hose from hose hooks.

**Important:** Do not pull the hose with the spray gun. Always hold the hose and pull on it directly. Pulling on the hose with the gun may break the fitting on the gun or damage the hose.

2. Release the trigger lock.
3. Direct the spray gun nozzle at the area to be sprayed and pull the trigger.
4. Release the trigger and set the trigger lock when finished.

## Switching from Hand Spray Mode to Boom Spray Mode

1. Press the rate control switch to reduce the pressure.
2. Set the spray selection switch to the off position.
3. Direct the spray gun nozzle at an area where it is safe to spray, release the trigger lock, and pull the trigger until all remaining fluid is out of the hose, then set the trigger lock.
4. Wrap the hose around the hooks of the tank and secure the gun as shown in Figure 14.

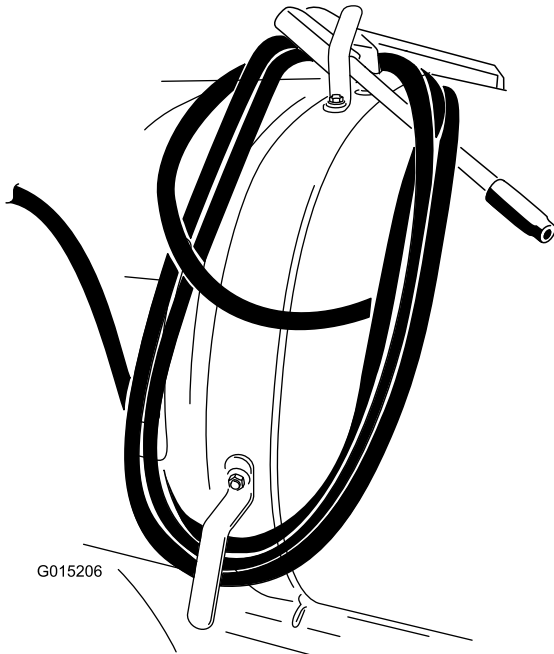

**Figure 14**

**Notes:**



**Count on it.**