



**Count on it.**

**Parts Catalog**

**21in Heavy-Duty**

**Recycler®/Rear Bagger Lawn Mower**

**Model No. 22195—Serial No. 311000001 and Up**

# Ordering Replacement Parts

To order replacement parts, please supply the part number, the quantity, and the description of each part desired.

## Understanding Reference Numbers

Each identified part in an illustration has a reference number. The reference number for a part also appears in the parts list, along with other information about the part.

This catalog uses two special reference number formats, one to indicate parts in a service assembly and another to indicate the quantity of a given part in an illustration.

## Service Assembly Reference Numbers

Parts in service assemblies have reference numbers in the form a:b. The a represents the reference number of the entire service assembly and the b represents a sequential number unique to each part within the service assembly.

For example, a wheel assembly might be identified by reference number 6, the tire by 6:1, the valve by 6:2, and the wheel by 6:3. When you order the assembly identified by reference number 6, you receive all parts identified by reference numbers 6:1, 6:2, and 6:3. However, you may also order any part individually. Reference numbers of this type appear in illustration and in parts lists.

## Reference Numbers Indicating Quantity

In an illustration, if a reference number indicates more than one part, the reference number has the form nX y. The n represents the quantity of the part, the X is the multiplication symbol, and the y represents the reference number.

For example, in an illustration, the reference number 2X 37 means that two of the parts identified by reference number 37 are indicated.

# List of Abbreviations

**AR:** as required

**ASM:** assembly

**BBC:** blade brake control

**BHTF:** button head thread forming

**CARR:** carriage

**CCW:** counter clockwise

**CW:** clockwise

**DEG:** degrees

**DPA:** Dual Point Adjustment

**ECM:** electronic control module

**EXT:** external

**FH:** flat head

**GA:** gauge

**HD:** heavy-duty

**HF:** hex flange

**HH:** hex head

**HHF:** hex head flange

**HHFTF:** hex head flange thread forming

**HJ:** hex jam

**HLH:** hex lag head

**HOC:** height-of-cut

**HSBH:** hex socket button head

**HSFH:** hex socket flat head

**HSH:** hex socket head

**HWH:** hex washer head

**HWTF:** hex washer head thread forming

**HYD:** hydraulic

**LH:** left hand

**LP:** Liquid Propane

**NI:** nylon insert

**NPTF:** national pipe thread fine

**PFH:** phillips flat head

**PPH:** phillips pan head

**PPHTF:** phillips pan head thread forming

**PRH:** phillips round head

**PTH:** phillips truss head

**PTO:** power-take-off

**RH:** right hand

**ROPS:** roll-over protection system

**RRB:** rear roller brush

**SFH:** slotted fillister head

**SHH:** slotted hex head

**SHWH:** slotted hex washer head

**SPH:** slotted pan head

**SQH:** square head

**SRH:** slotted round head

**STD:** standard

**TAP:** self tapping

**TTH:** torx truss head

# Contents

Housing Assembly .....	4
Housing Assembly No. 98-7139 .....	6
Front Wheel and Tire Assembly No. 100-2870 .....	7
Gear Case Assembly No. 74-1860 .....	8
Engine, Fuel Tank and Blade Assembly .....	9
Handle Assembly .....	10
Rear Drive and Wheel Assembly .....	12
Rear Wheel Assembly No. 100-2860 .....	13
Attachments and Accessories .....	14

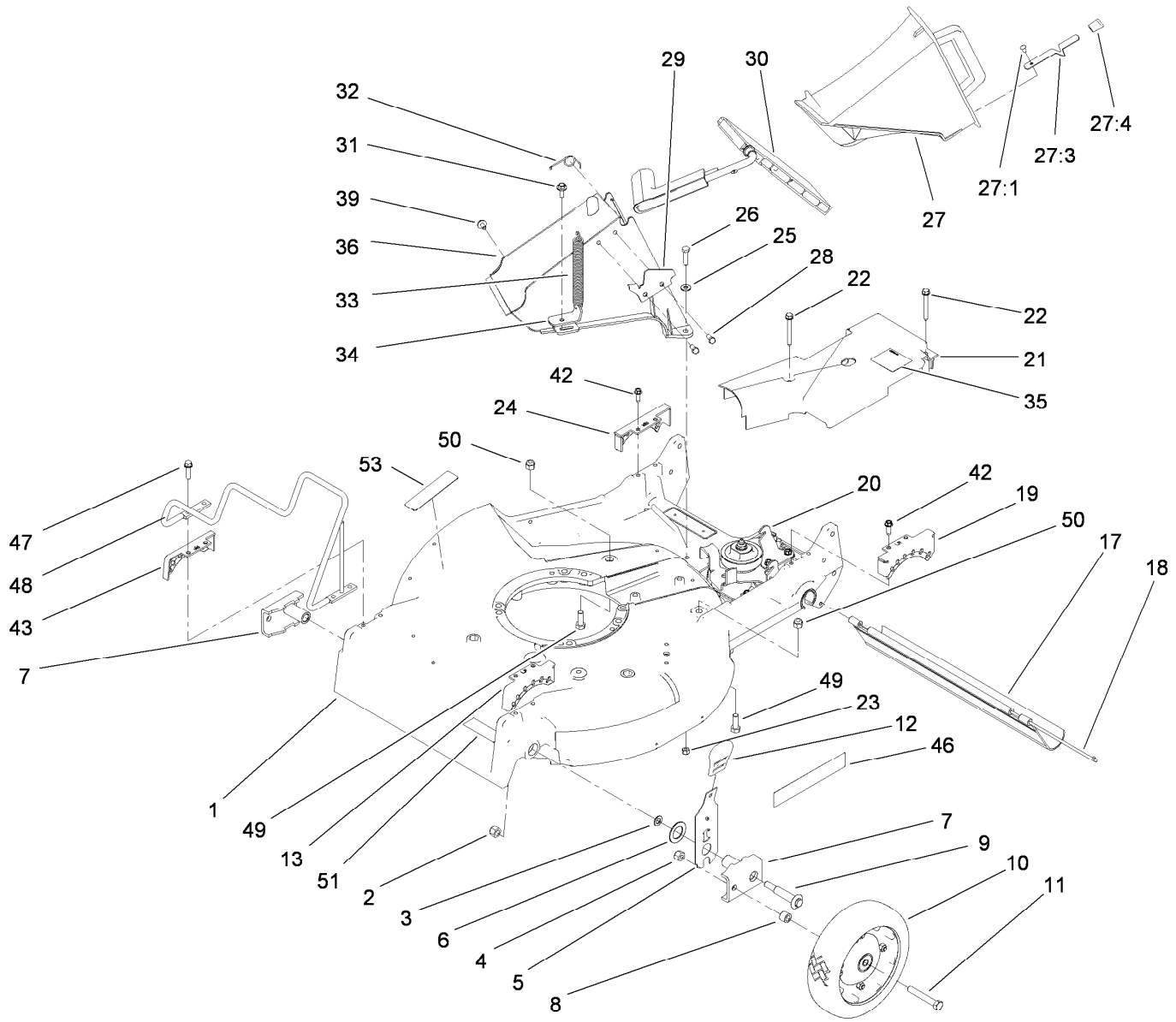

## Housing Assembly

Ref.	Part Number	Qty.	Description	Ref.	Part Number	Qty.	Description
1	98-7139	1	Housing	25	3256-22	2	Washer-Flat
2	3296-6	2	Nut-Lock	26	321-8	2	Screw-HH
3	40-1940	2	Washer	27	77-0500	1	Discharge Plug ASM
4	32152-2	2	Nut-Lock, Cone	27:1	3295-35	1	Rivet-Head, Flat
5	119-2323	2	Front Spring Arm ASM	27:3	76-4640	1	Latch-Plug, Discharge
6	257-3	2	Washer-Thrust	27:4	76-4650	1	Grip-Latch
7	61-8300	2	Arm-Pivot, Front	28	46-8090	2	Screw-Plastite
8	52-2480	2	Spacer-Wheel	29	93-3154	1	Latch-Plate
9	114-3468	2	Screw-Shoulder	30	93-7351	1	Discharge Door ASM
10	100-2870	2	Wheel And Tire ASM	31	46-6811	1	Screw-HWH
11	323-12	2	Screw-HH	32	80-3770	1	Retainer-Door
12	110-0549	2	Knob-HOC	33	76-4660	1	Spring-Door
13	49-8760	1	Quadrant-Front, LH	34	71-9350	1	Bracket-Spring
17	112-9989	1	Shield-Trailing	35	52-2620	1	Label-Grease
18	33-3208	1	Rod-Shield	36	82-9152	1	Tunnel-Discharge
19	49-8740	1	Quadrant-Rear, LH	39	46-6810	1	Screw And Washer ASM
20	74-1860	1	Gear Case ASM	42	49-2040	4	Screw-HWHTF
21	74-1770	1	Cover-Belt	43	49-8770	1	Quadrant-Front, RH
22	117-5248	2	Screw-HWH, Thrd Form	46	106-0689	1	Decal
23	3296-42	2	Nut-Lock, NI	47	32144-86	4	Screw-HWHTF
24	49-8750	1	Quadrant-Rear, RH	48	109-7638	1	Guard-Engine

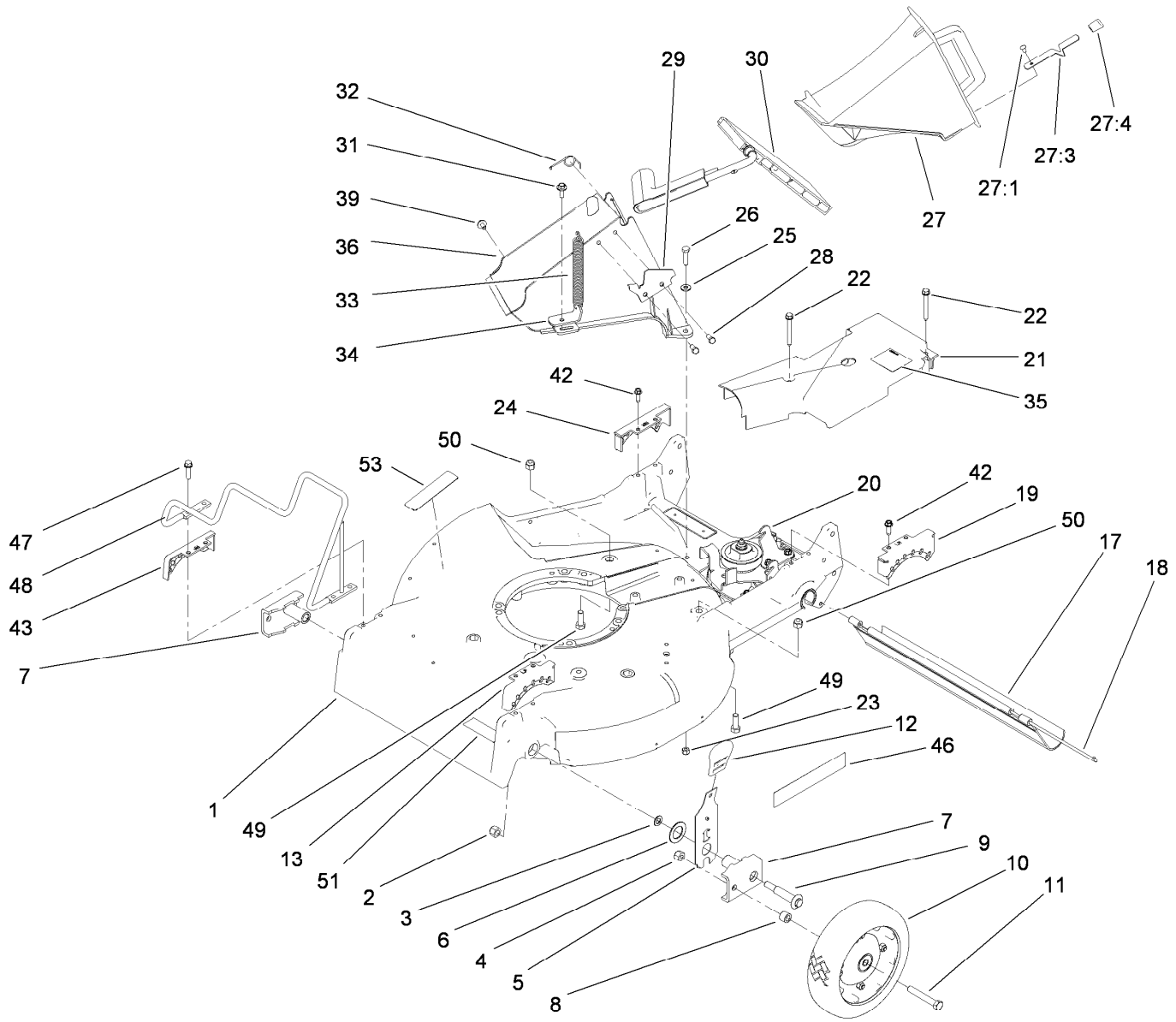

## Housing Assembly (continued)

<i>Ref.</i>	<i>Part Number</i>	<i>Qty.</i>	<i>Description</i>
49	323-6	2	Screw-HH
50	3296-39	2	Nut-Lock, NI

<i>Ref.</i>	<i>Part Number</i>	<i>Qty.</i>	<i>Description</i>
51	68-7410	1	Decal-Blade
53	117-2718	1	Decal-Arrester, Spark

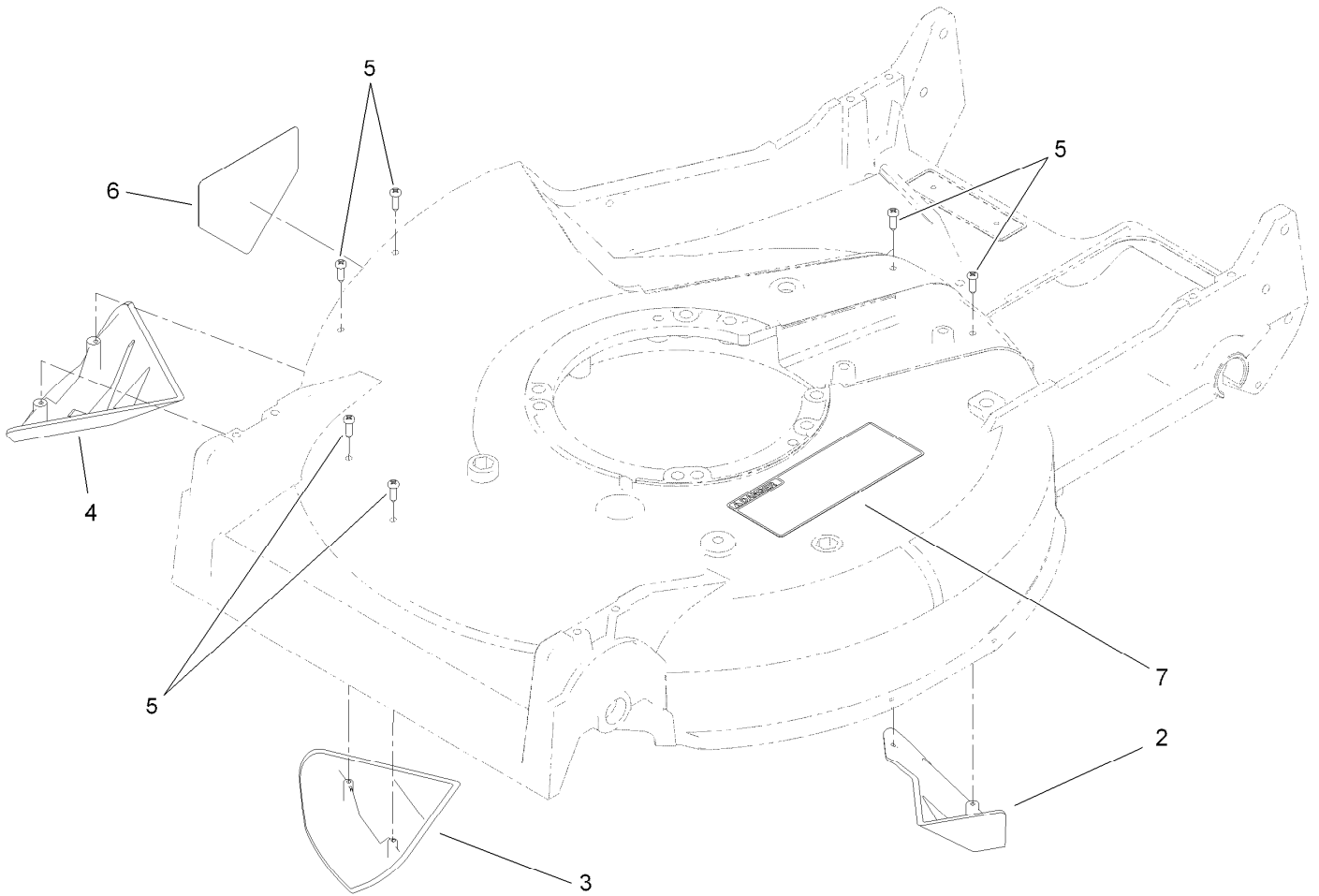

## Housing Assembly No. 98-7139

<i>Ref.</i>	<i>Part Number</i>	<i>Qty.</i>	<i>Description</i>
2	92-1750	1	Kicker-Rear
3	92-1720	1	Kicker-Front
4	92-1730	1	Kicker-RH
5	32144-111	6	Screw-PPH
6	94-8072	1	Decal-Danger
7	110-4989	1	Decal-Warning

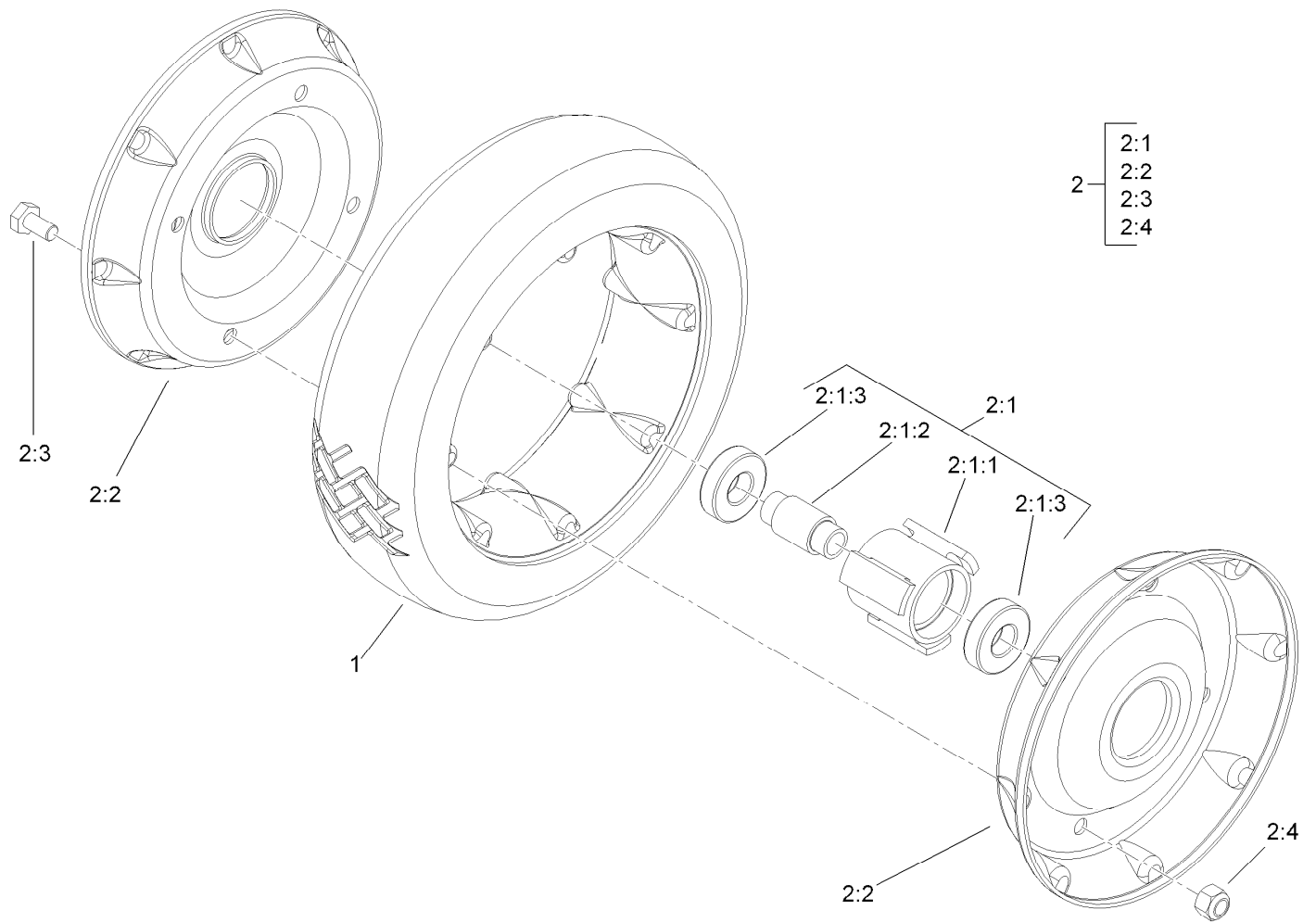

## Front Wheel and Tire Assembly No. 100-2870

<i>Ref.</i>	<i>Part Number</i>	<i>Qty.</i>	<i>Description</i>
1	53-7740	1	Tire
2		1	Wheel ASM ●
2:1		1	Hub And Bearing ASM ●
2:1:1	52-2410	1	Hub-Bearing
2:1:2	52-2440	1	Spacer-Bearing
2:1:3	52-2450	2	Bearing-Wheel
2:2	53-7780-06	2	Plate-Wheel, Half
2:3	321-2	4	Screw-HH
2:4	3296-42	4	Nut-Lock, NI

● Not serviced separately

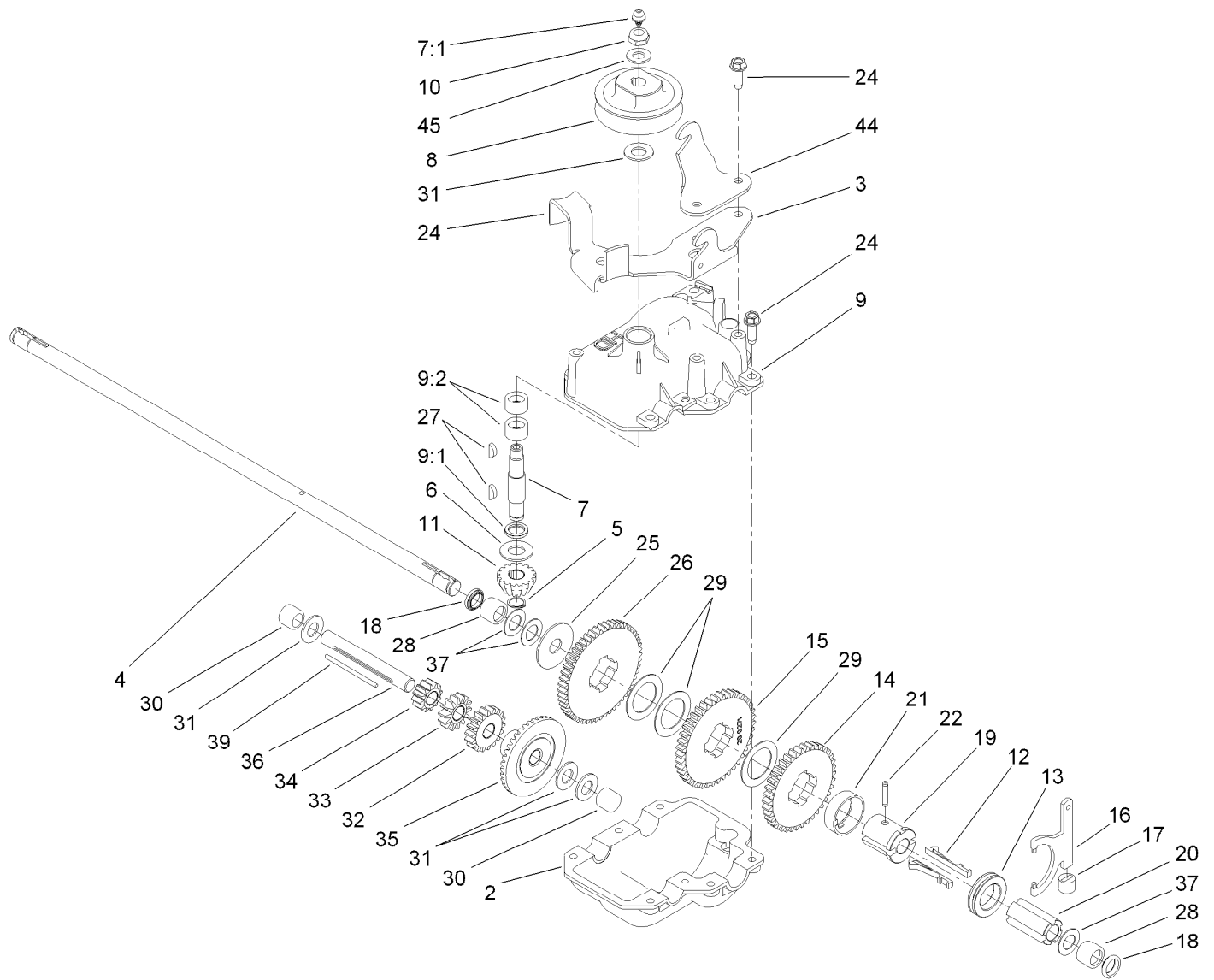

## Gear Case Assembly No. 74-1860

Ref.	Part Number	Qty.	Description	Ref.	Part Number	Qty.	Description
2	74-1920	1	Case-Gear, Lower	20	39-6720	1	Sleeve
3	49-8461-03	1	Bracket-Guide, Belt	21	55-8020	1	Retainer-Key
4	74-1890	1	Shaft-Output	22	3285-19	1	Pin-Groove
5	32151-57	1	Ring-Retaining	24	49-2040	8	Screw-HWHTF
6	47-2910	1	Washer-Thrust	25	29-9690	1	Washer
7	13-5149	1	Input Shaft ASM	26	46-3560	1	Gear
7:1	302-63	1	Zerk	27	3257-1	2	Key-Woodruff
8	39-6740	1	Pulley	28	117-3500	2	Bearing-Caged Needle Roller
9	13-9739	1	Upper Gearcase ASM	29	36-4770	3	Washer
9:1	47-7260	1	Seal	30	252-103	2	Bearing-Closed
9:2	47-7270	2	Bearing	31	36-4792	4	Washer-Thrust
10	3296-5	1	Nut-Lock	32	39-6650	1	Gear-18T
11	39-6660	1	Pinion-Bevel	33	46-3550	1	Gear-14T
12	29-9330	2	Key-Shift	34	46-3540	1	Gear-12T
13	29-9340	1	Collar-Shift	35	74-1760	1	Gear-Bevel
14	42-4740	1	Gear-38T	36	53-7950	1	Shaft-Intermediate
15	29-9271	1	Gear-42T	37	36-4780	3	Washer-Plain
16	60-8870	1	Yoke-Shift	39	39-7842	1	Key
17	29-9570	1	Bushing-Yoke	44	74-1750-03	1	Bracket-Engage, Traction
18	47-6730	2	Seal-Oil	45	3256-45	1	Washer-Flat
19	55-8010	1	Sleeve-Gear				



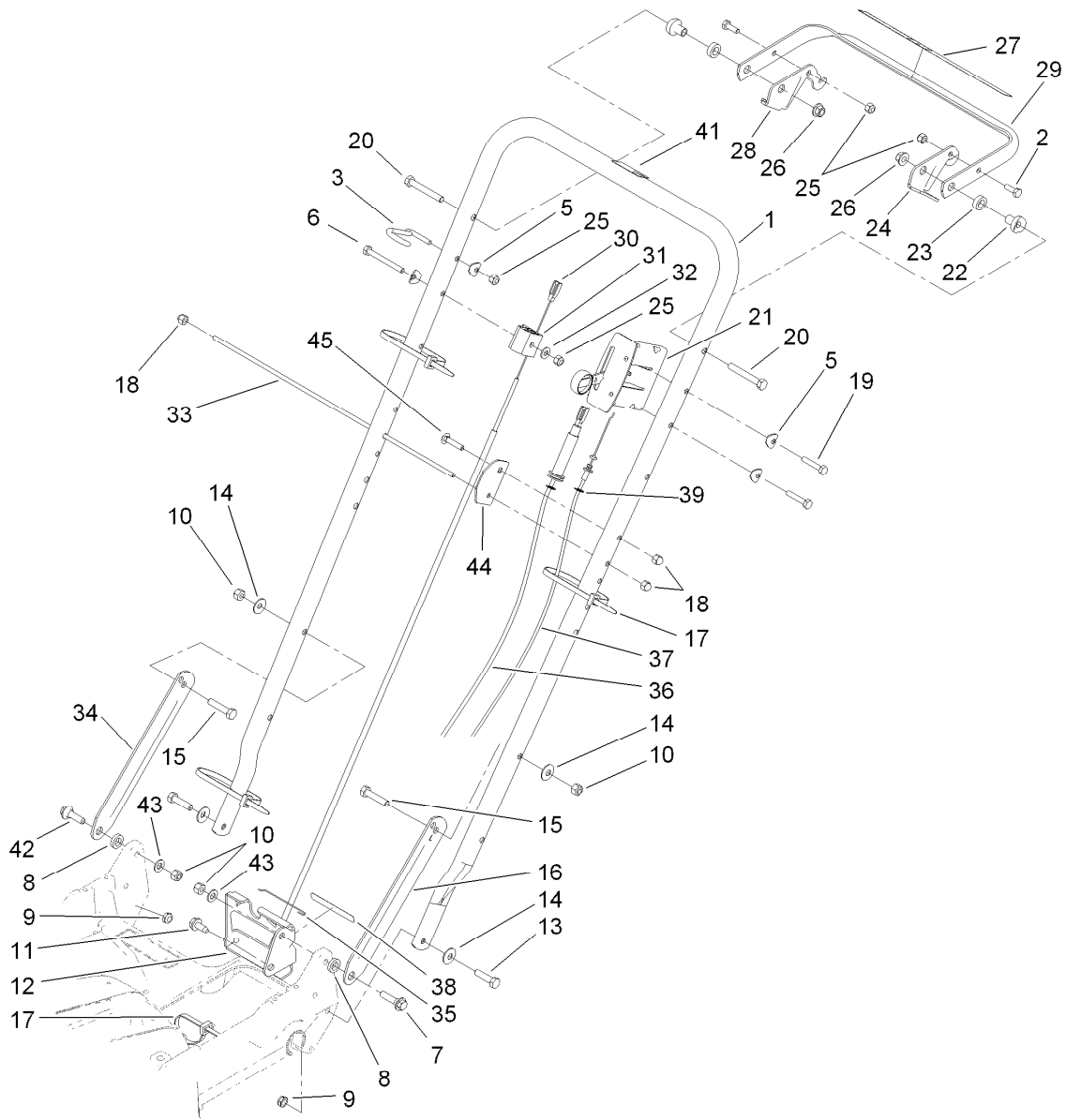

## Handle Assembly

<i>Ref.</i>	<i>Part Number</i>	<i>Qty.</i>	<i>Description</i>	<i>Ref.</i>	<i>Part Number</i>	<i>Qty.</i>	<i>Description</i>
1	98-2000-03	1	Handle	22	49-1630	2	Spacer-Support
2	321-4	2	Screw-HH	23	256-276	2	Spacer-Nylon
3	114-2775	1	Guide-Rope	24	66-5350	1	Lever-Control
5	3-7501	4	Washer	25	3296-42	4	Nut-Lock, NI
6	321-15	1	Screw-HH	26	3296-58	2	Nut-Lock, NI
7	27-7210	1	Screw-Shoulder	27	106-0690	1	Decal-Traction
8	3-3287	2	Spacer-Latch, Handle	28	77-5270	1	Lever-Control
9	3296-47	2	Nut-Lock, NI	29	61-8270-03	1	Bar-Control
10	3296-29	4	Nut-Lock, NI	30	119-7869	1	Cable-Control, Brake
11	32144-70	1	Screw-HWHTF	31	46-6980	1	Support-Cable
12	74-1741	1	Bracket-Adjustment, Traction	32	3256-22	1	Washer-Flat
13	322-6	2	Screw-HH	33	48-2810	1	Rod-Support, Bag
14	3290-456	4	Washer-Belleville	34	100-3297-03	1	Latch-Handle, RH
15	322-7	2	Screw-HH	35	46-7030	1	Retainer-Cable
16	100-3298-03	1	Latch-Handle, LH	36	74-1791	1	Cable-Traction
17	3290-378	4	Tie-Cable	37	106-0888	1	Throttle Cable ASM
18	32111-7	3	Nut-Cap	38	74-1970	1	Decal-Position, Gear
19	321-13	2	Screw-HH	39	32151-86	2	E-Ring
20	322-11	2	Screw-HH	41	98-4387	1	Decal-Protection, Ear
21	108-2645	1	Control-Head, Throttle	42	27-7211	1	Screw-Shoulder
				43	3256-23	2	Washer-Flat

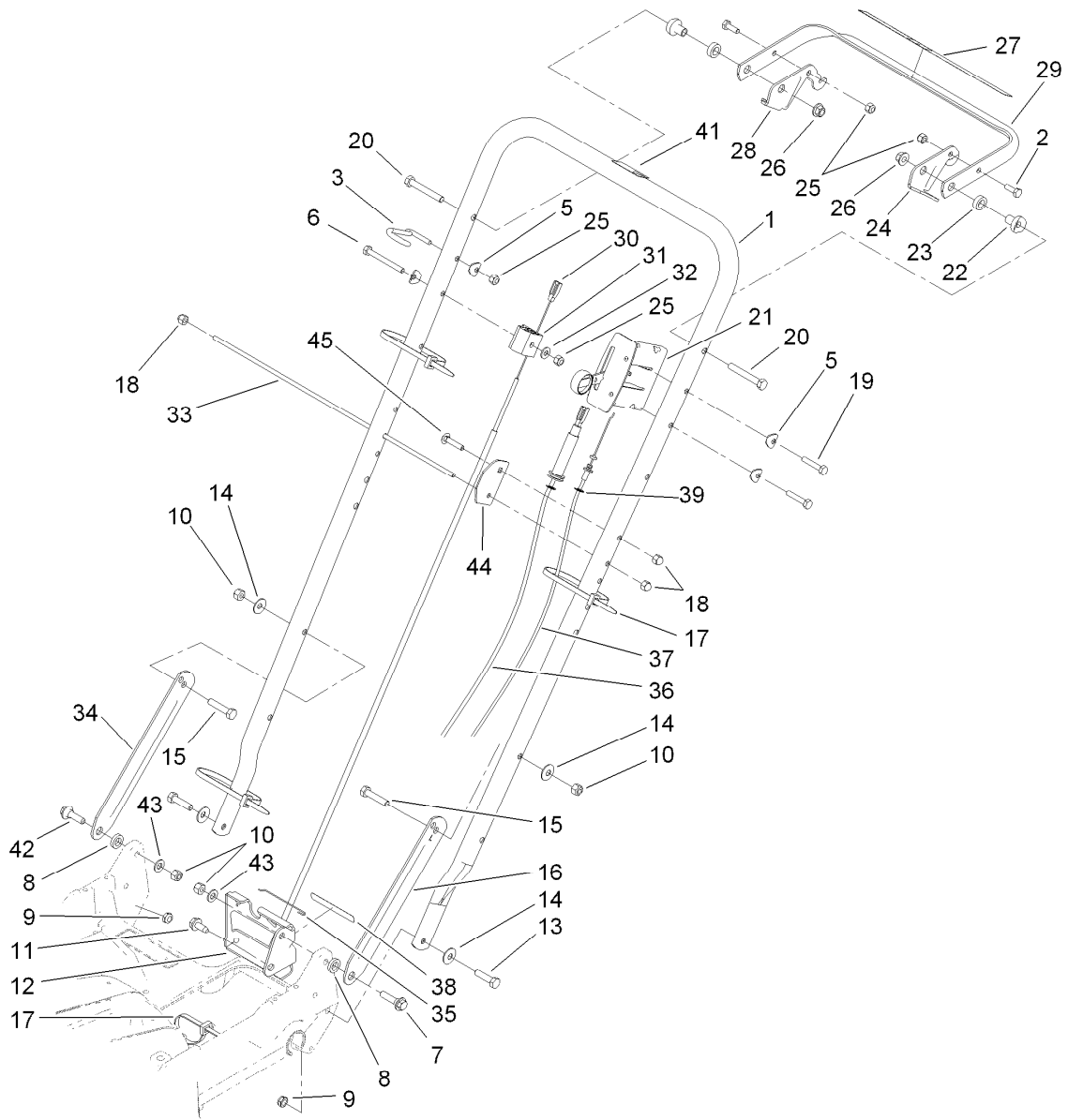

## Handle Assembly (continued)

<i>Ref.</i>	<i>Part Number</i>	<i>Qty.</i>	<i>Description</i>
44	104-1326	1	Plate-Aligning, Bag
45	3229-3	1	Screw-CARR

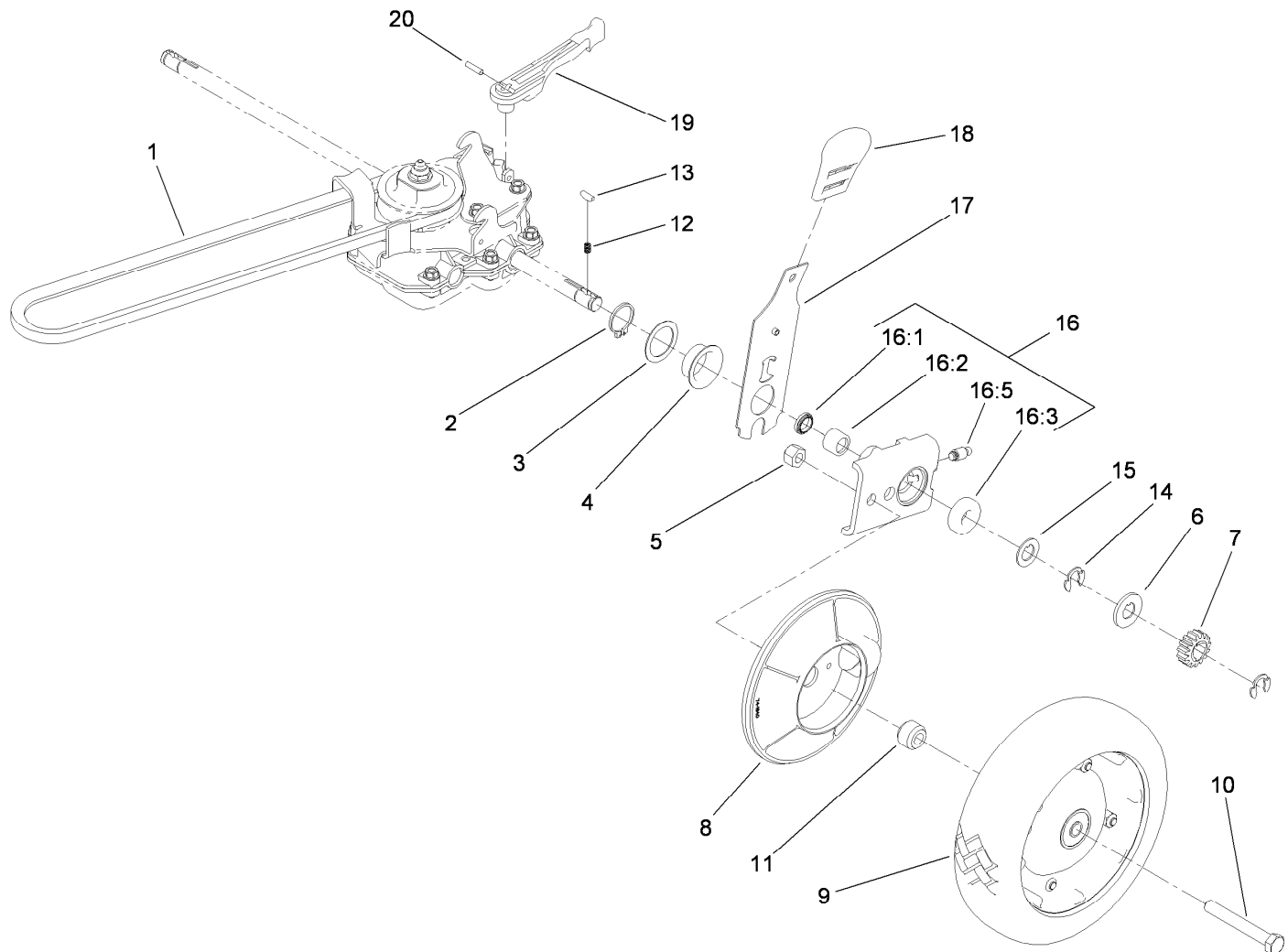

## Rear Drive and Wheel Assembly

<i>Ref.</i>	<i>Part Number</i>	<i>Qty.</i>	<i>Description</i>
1	36-8070	1	V-Belt
2	32151-36	2	Ring-Retaining
3	74-1810	2	Washer
4	48-2170	2	Cap-End
5	32152-2	2	Nut-Lock, Cone
6	62-3830	2	Washer-Thrust, Outer
7	39-9160	2	Gear-Pinion
8	74-1640	2	Cover-Wheel
9	100-2860	2	Wheel And Tire ASM
10	323-13	2	Screw-HH
11	74-1650	2	Spacer-Cover, Wheel
12	39-9650	2	Spring-Compression
13	612066	2	Key
14	32151-68	4	Ring-Retaining
15	49-7700	2	Washer-Thrust, Outer
16	74-1851	2	Pivot Arm ASM
16:1	47-6730	1	Seal-Oil
16:2	117-3500	1	Bearing-Caged Needle Roller
16:3	52-2450	1	Bearing-Wheel
16:5	92-6316	1	Zerk
17	119-2324	2	Rear Spring Arm ASM
18	110-0549	2	Knob-HOC
19	74-1960	1	Lever-Shift
20	32121-99	1	Pin-Coil

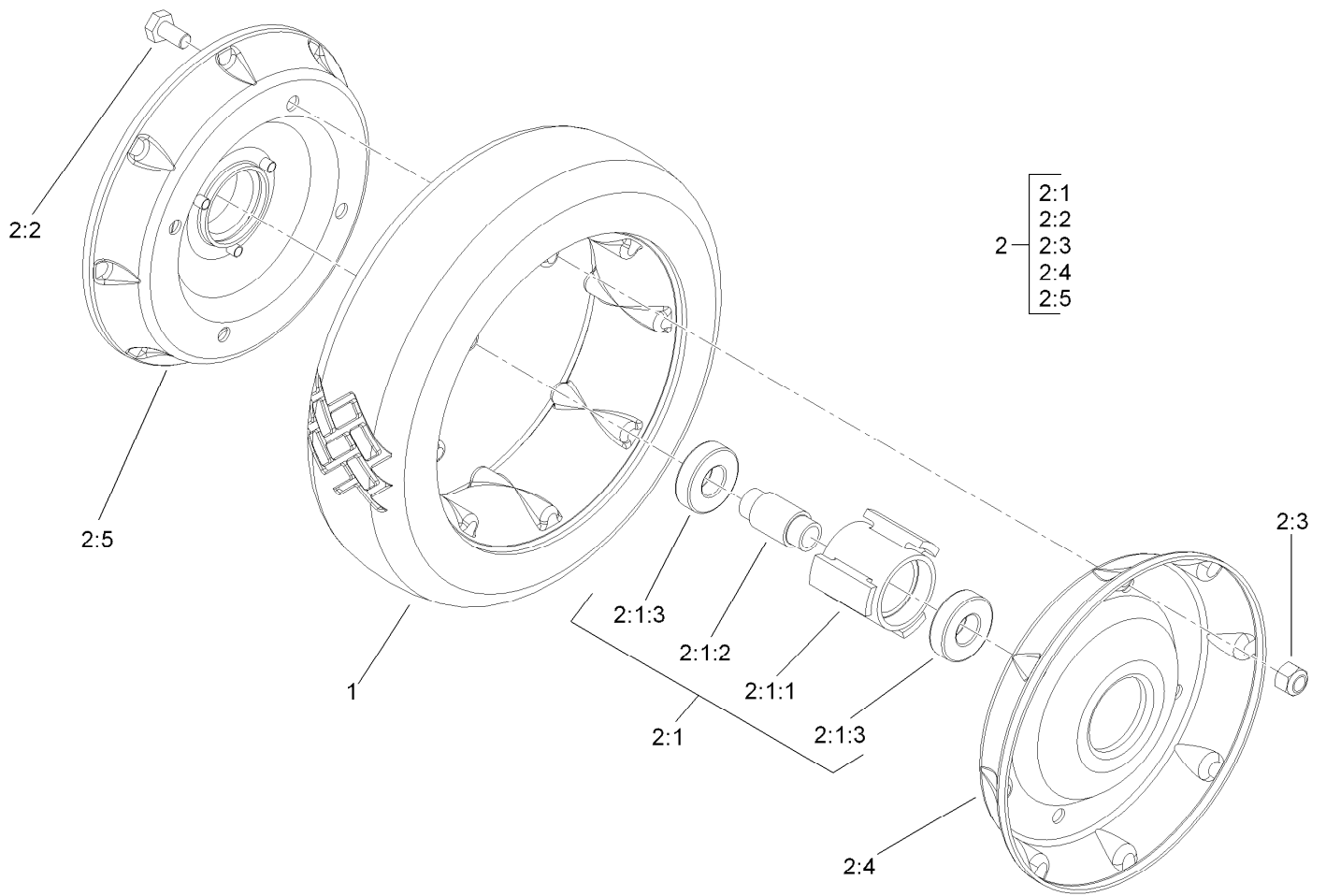

## Rear Wheel Assembly No. 100-2860

Ref.	Part Number	Qty.	Description
1	53-7740	1	Tire
2		1	Wheel ASM ●
2:1		1	Hub And Bearing ASM ●
2:1:1	52-2410	1	Hub-Bearing
2:1:2	52-2440	1	Spacer-Bearing
2:1:3	52-2450	2	Bearing-Wheel
2:2	321-2	4	Screw-HH
2:3	3296-42	4	Nut-Lock, NI
2:4	53-7780-06	1	Plate-Wheel, Half
2:5	92-4957-06	1	Wheel Half And Gear ASM

● Not serviced separately

# Attachments and Accessories

## For 22195 21in Heavy-Duty Recycler/Rear Bagger Lawn Mower

<b>Product Name</b>	<b>Model/Part</b>
Blade-Atomic, 21in .....	104-1302
Bag-Large, Walk Behind (Toro).....	490-7315
Bag-Walk Behind (Toro).....	490-7318
Bag-Large, Walk Behind (No Logo) .....	490-7322
Bag-Walk Behind (No Logo) .....	490-7325
Cover-Lawnmower .....	490-7462
Side Discharge Kit .....	59199

**Notes:**



**Count on it.**