



**Count on it.**

**Parts Catalog**

**Commercial Walk-Behind Mower  
16HP, T-Bar, Gear Drive with 91cm TURBO  
FORCE® Cutting Unit**

**Model No. 30070—Serial No. 311000001 and Up**

# Ordering Replacement Parts

To order replacement parts, please supply the part number, the quantity, and the description of each part desired.

## Understanding Reference Numbers

Each identified part in an illustration has a reference number. The reference number for a part also appears in the parts list, along with other information about the part.

This catalog uses two special reference number formats, one to indicate parts in a service assembly and another to indicate the quantity of a given part in an illustration.

## Service Assembly Reference Numbers

Parts in service assemblies have reference numbers in the form a:b. The a represents the reference number of the entire service assembly and the b represents a sequential number unique to each part within the service assembly.

For example, a wheel assembly might be identified by reference number 6, the tire by 6:1, the valve by 6:2, and the wheel by 6:3. When you order the assembly identified by reference number 6, you receive all parts identified by reference numbers 6:1, 6:2, and 6:3. However, you may also order any part individually. Reference numbers of this type appear in illustration and in parts lists.

## Reference Numbers Indicating Quantity

In an illustration, if a reference number indicates more than one part, the reference number has the form nX y. The n represents the quantity of the part, the X is the multiplication symbol, and the y represents the reference number.

For example, in an illustration, the reference number 2X 37 means that two of the parts identified by reference number 37 are indicated.

# List of Abbreviations

**AR:** as required

**ASM:** assembly

**BBC:** blade brake control

**BHTF:** button head thread forming

**CARR:** carriage

**CCW:** counter clockwise

**CW:** clockwise

**DEG:** degrees

**DPA:** Dual Point Adjustment

**ECM:** electronic control module

**EXT:** external

**FH:** flat head

**GA:** gauge

**HD:** heavy-duty

**HF:** hex flange

**HH:** hex head

**HHF:** hex head flange

**HHFTF:** hex head flange thread forming

**HJ:** hex jam

**HLH:** hex lag head

**HOC:** height-of-cut

**HSBH:** hex socket button head

**HSFH:** hex socket flat head

**HSH:** hex socket head

**HWH:** hex washer head

**HWTF:** hex washer head thread forming

**HYD:** hydraulic

**LH:** left hand

**LP:** Liquid Propane

**NI:** nylon insert

**NPTF:** national pipe thread fine

**PFH:** phillips flat head

**PPH:** phillips pan head

**PPHTF:** phillips pan head thread forming

**PRH:** phillips round head

**PTH:** phillips truss head

**PTO:** power-take-off

**RH:** right hand

**ROPS:** roll-over protection system

**RRB:** rear roller brush

**SFH:** slotted fillister head

**SHH:** slotted hex head

**SHWH:** slotted hex washer head

**SPH:** slotted pan head

**SQH:** square head

**SRH:** slotted round head

**STD:** standard

**TAP:** self tapping

**TTH:** torx truss head

# Contents

Engine and Clutch Assembly .....	4
Power-Take-Off Idler Assembly .....	5
Fuel System Assembly .....	6
Lower Control Assembly .....	7
Transmission Drive Assembly .....	8
Wheel Drive and Brake Assembly .....	9
Handle Assembly .....	10
Control Panel Assembly .....	11
Carrier Frame Assembly .....	12
Deck Drive and Baffle Assembly .....	13
Deck Decal Assembly No. 115-4230 .....	14
Spindle Assembly No. 110-6950 .....	15
Spindle Assembly No. 110-0728 .....	16
Deck Deflector, Roller and Cover Assembly .....	17
Deflector Assembly No. 110-0790 .....	18
Attachments and Accessories .....	19

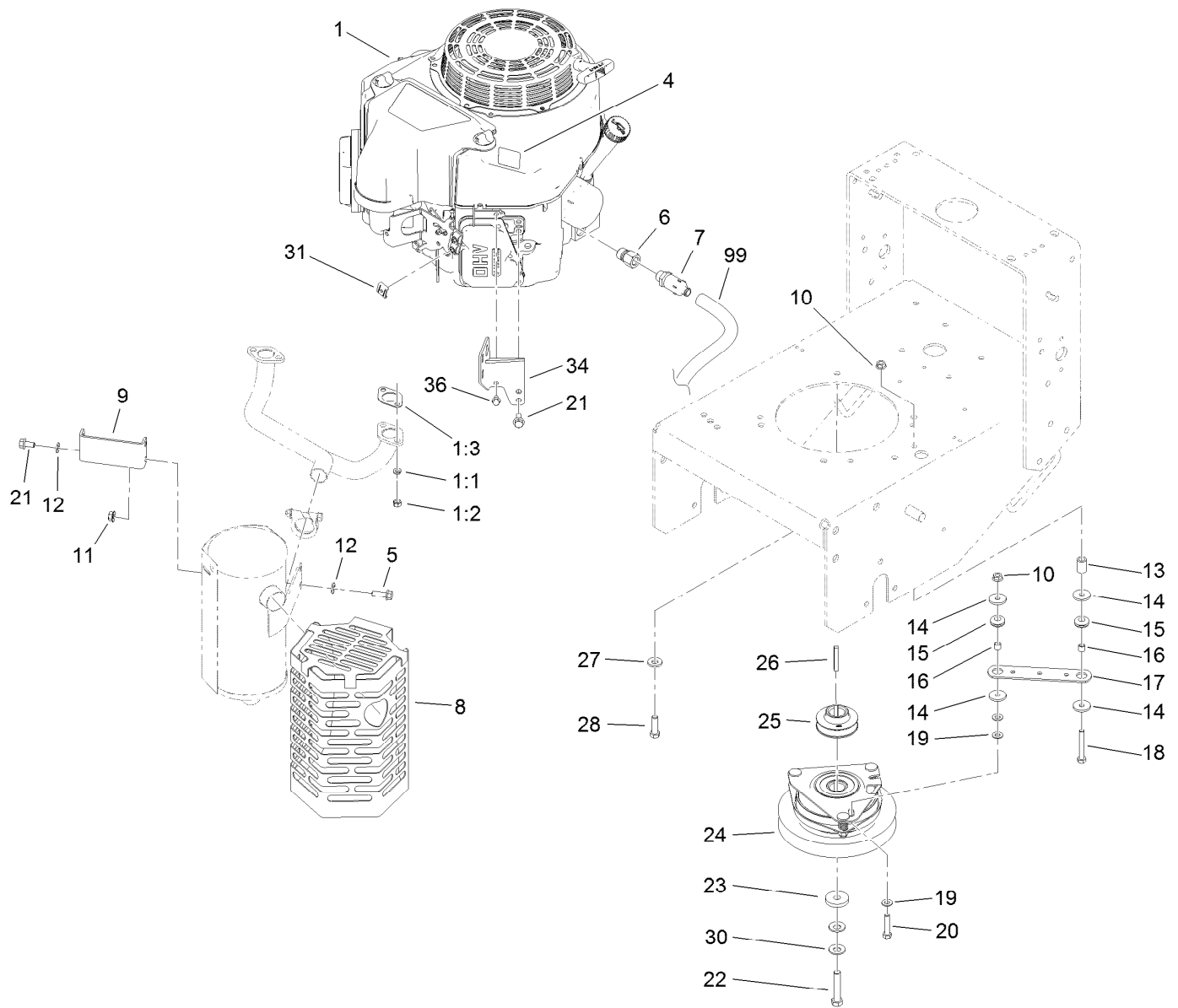

## Engine and Clutch Assembly

Ref.	Part Number	Qty.	Description
1		1	Engine-Kawasaki, Fs481V-As52 ●■
1:1	114-3550	4	Washer-Lock, Spring
1:2	114-3549	4	Nut
1:3	1-653313	2	Gasket-Exhaust
4	106-5517	1	Decal-Warning, Hot Surface
5	33104-025	4	Screw-HHF
6	103-1966	1	Adapter
7	92-6877	1	Valve-Drain, Oil
8	119-3629-03	1	Muffler Shield ASM
9	119-3635-03	1	Bracket-Shield, Muffler
10	32128-20	2	Nut-HF
11	117-1350	4	Nut-HF, Lock
12	1-303334	4	Washer-Spring
13	104-6373	1	Tube-Retainer
14	1-613235	4	Washer
15	1-633630	2	Grommet
16	1-633545	2	Spacer

Ref.	Part Number	Qty.	Description
17	1-633543-03	1	Strap-Clutch, Brake
18	322-11	1	Screw-HH
19	3256-23	3	Washer-Flat
20	322-7	1	Screw-HH
21	33104-016	2	Screw-HHF
22	3212-9	1	Screw-HH
23	107-4136	1	Washer
24	105-2635	1	Clutch / Brake ASM
25	107-4112	1	Pulley-Drive
26	608006	1	Key-Square
27	98-5975	4	Washer-Belleville
28	323-7	4	Screw-HH
30	1-603610	2	Washer-Spring
31	81-1690	1	Clamp-Cable
34	117-8561-03	1	Bracket-Muffler
36	33103-012	1	Screw-HHF
99	103-1964	1	Hose-Drain, Oil

● Not serviced separately

■ Obtain parts from [www.kawpowerepc.com](http://www.kawpowerepc.com)

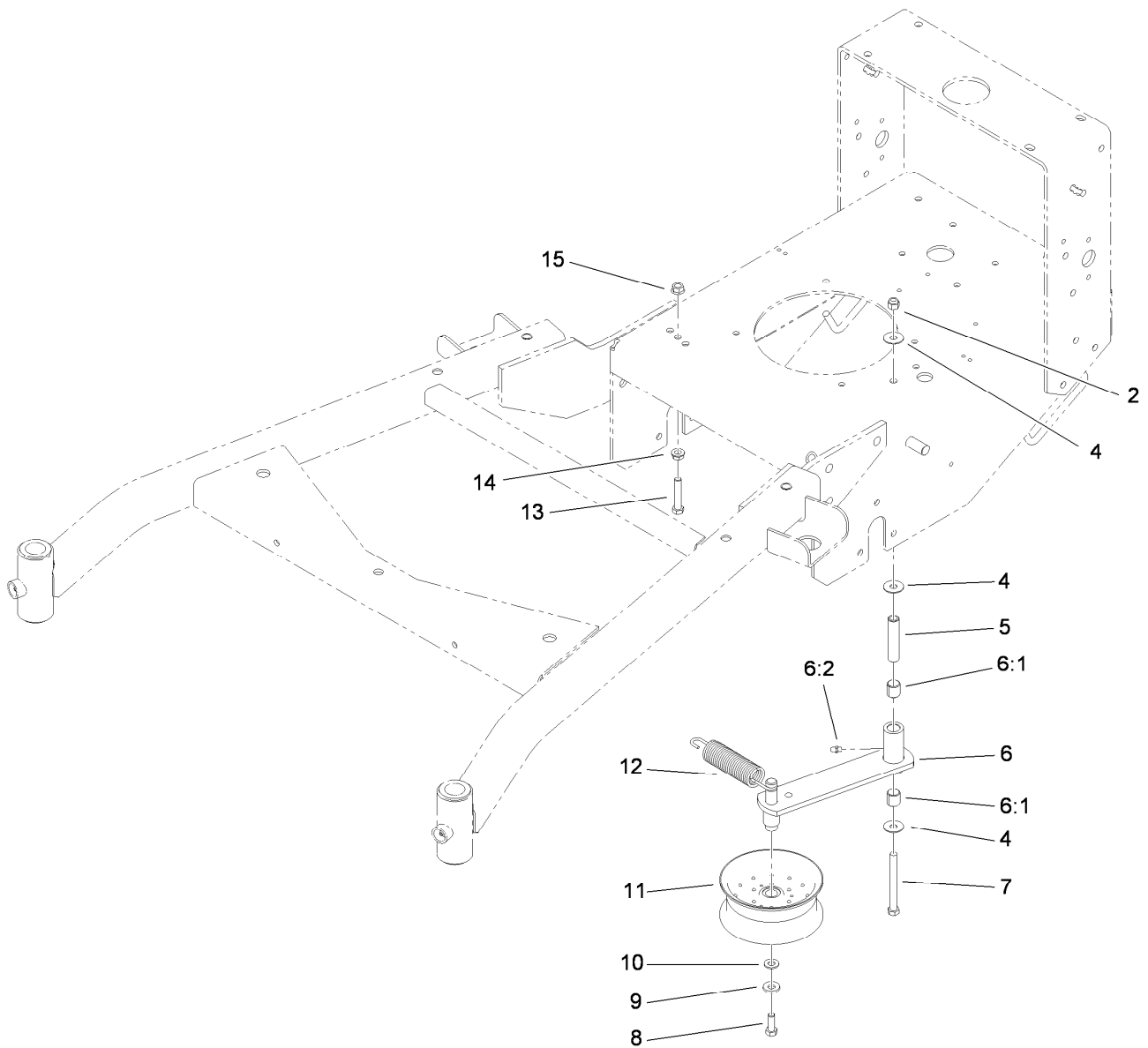

## Power-Take-Off Idler Assembly

Ref.	Part Number	Qty.	Description
2	3296-39	1	Nut-Lock, NI
4	52-2860	3	Washer
5	104-6377	1	Tube-Idler
6	112-7055	1	Idler Arm ASM
6:1	1-513034	2	Sleeve-Bearing
6:2	302-5	1	Fitting-Grease
7	323-42	1	Screw-HH
8	323-6	1	Screw-HH
9	98-5975	1	Washer-Belleville
10	3256-24	1	Washer-Flat
11	1-413099	1	Pulley-Idler
12	105-8443	1	Spring-Extension
13	323-10	1	Screw-HH
14	3290-357	1	Nut-HHF, Whiz
15	32128-21	1	Nut-HF

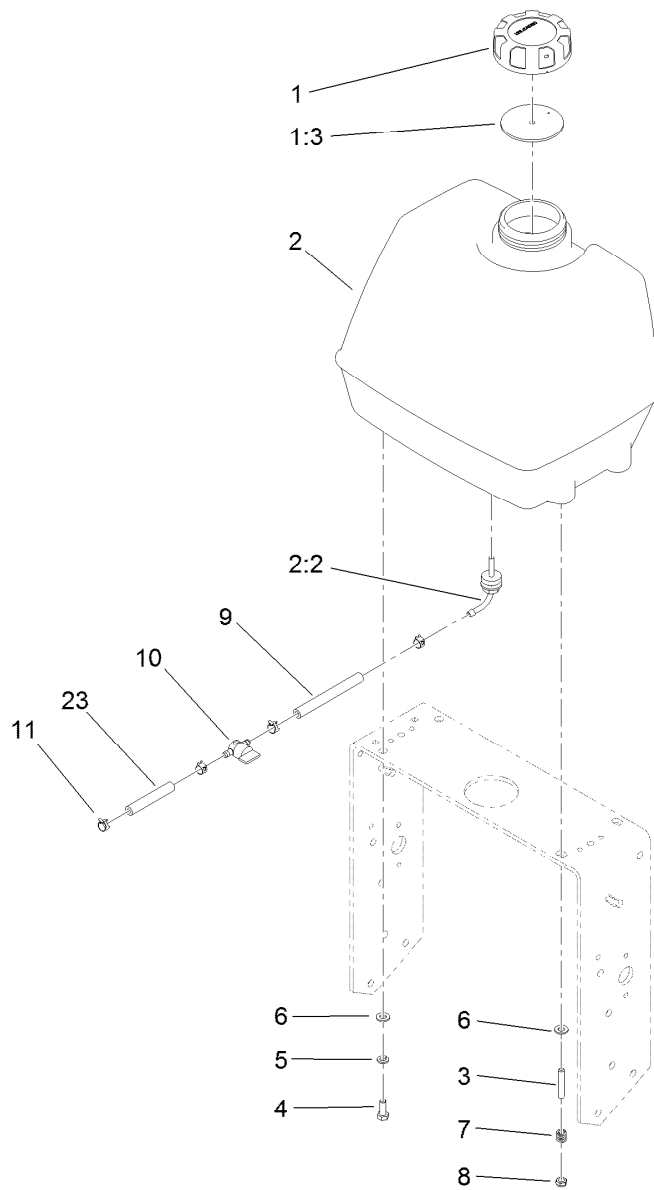

## Fuel System Assembly

Ref.	Part Number	Qty.	Description
1	88-3980	1	Gas Cap ASM
1:3	88-4010	1	Gasket-Cap, Gas
2	106-0730	1	Fuel Tank ASM
2:2	103-2605	1	Fitting-Fuel, Bulkhead
3	104-8121	2	Stud-Threaded
4	322-4	2	Screw-HH
5	3253-4	2	Washer-Lock
6	3256-23	4	Washer-Flat
7	1-633349	2	Spring-Tank, Fuel
8	3296-47	2	Nut-Lock, NI
9	109-0650	1	Hose-Fuel
10	1-603770	1	Valve-Fuel
11	2412-98	4	Clamp
23	99-9415	1	Hose-Fuel

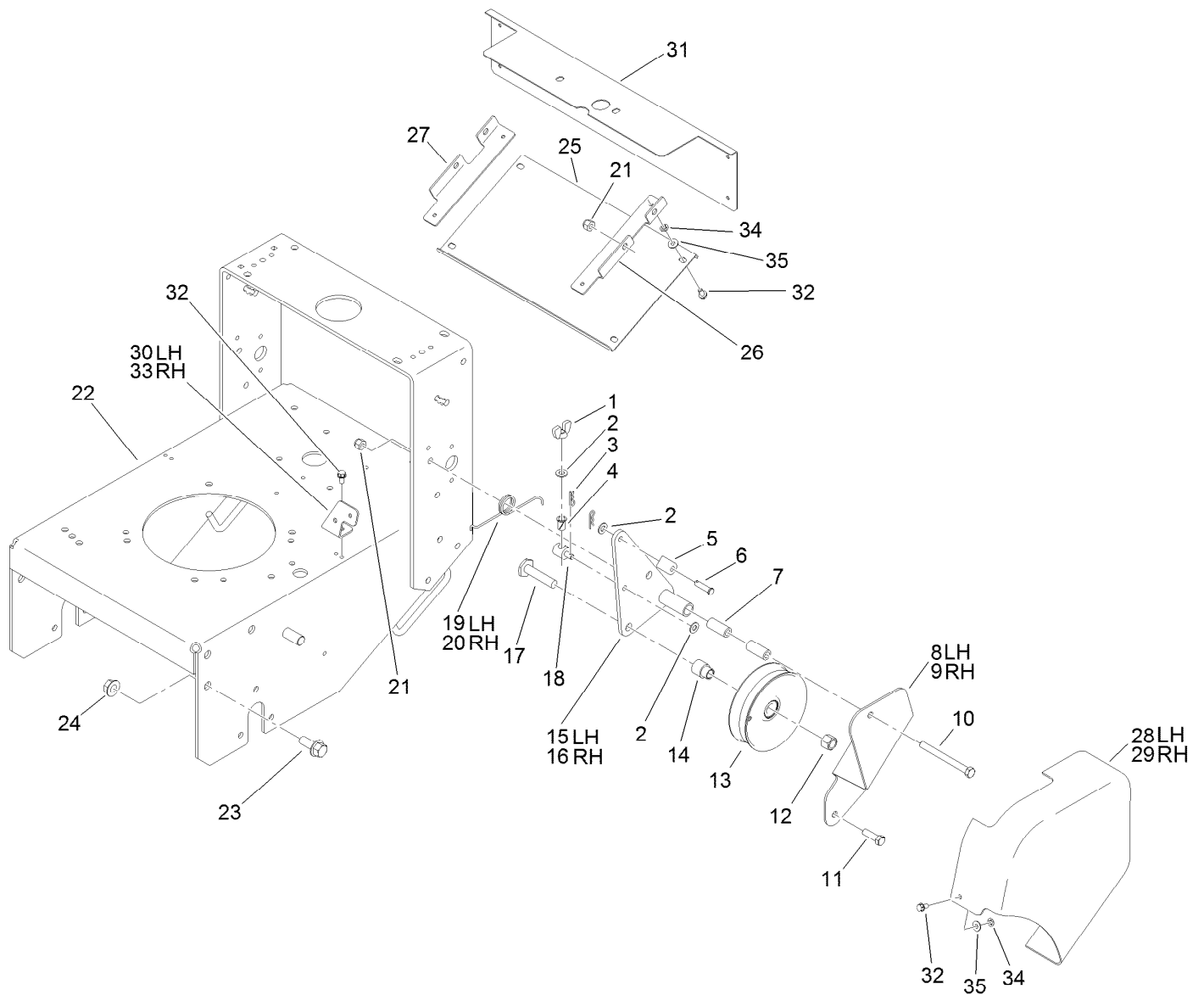

## Lower Control Assembly

<i>Ref.</i>	<i>Part Number</i>	<i>Qty.</i>	<i>Description</i>	<i>Ref.</i>	<i>Part Number</i>	<i>Qty.</i>	<i>Description</i>
1	32103-25	2	Nut-Wing	19	51-4380	1	Spring-Torsion, LH
2	3256-23	6	Washer-Flat	20	51-4370	1	Spring-Torsion, RH
3	3290-307	4	Pin-Hair	21	3296-39	6	Nut-Lock, NI
4	52-2890	2	Bushing-Nylon	22	117-3525-01	1	Gear Frame ASM
5	74-0521	2	Fitting-Rod	23	3234-32	6	Screw-HHF
6	283-6	2	Pin-Clevis	24	32128-23	6	Nut-HF
7	74-0040	4	Spacer-Pivot, Idler	25	110-5014-01	1	Panel-Bottom
8	108-2725-01	1	Support-Idler, LH	26	110-5012-01	1	Angle-Mounting, Left
9	108-2724-01	1	Support-Idler, RH	27	110-5013-01	1	Angle-Mounting, Right
10	323-16	2	Screw-HH	28	119-6509	1	Guard-Belt, LH
11	323-7	4	Screw-HH	29	119-6510	1	Guard-Belt, RH
12	3296-23	2	Nut-Lock, NI	30	107-4078-01	1	Bracket-Mounting, LH
13	95-2800	2	Pulley-Idler	31	104-8158-03	1	Guard-Shaft, Transmission
14	95-2801	2	Spacer-Pulley	32	32144-4	12	Screw-HWH
15	108-2740-01	1	LH Idler Arm ASM	33	107-4079-01	1	Bracket-Mounting, RH
16	108-2741-01	1	RH Idler Arm ASM	34	106-8737	8	Nut-Retainer
17	51-4450	2	Screw-Leveler	35	3256-1	8	Washer-Flat
18	68-9690	2	Fitting-Rod				

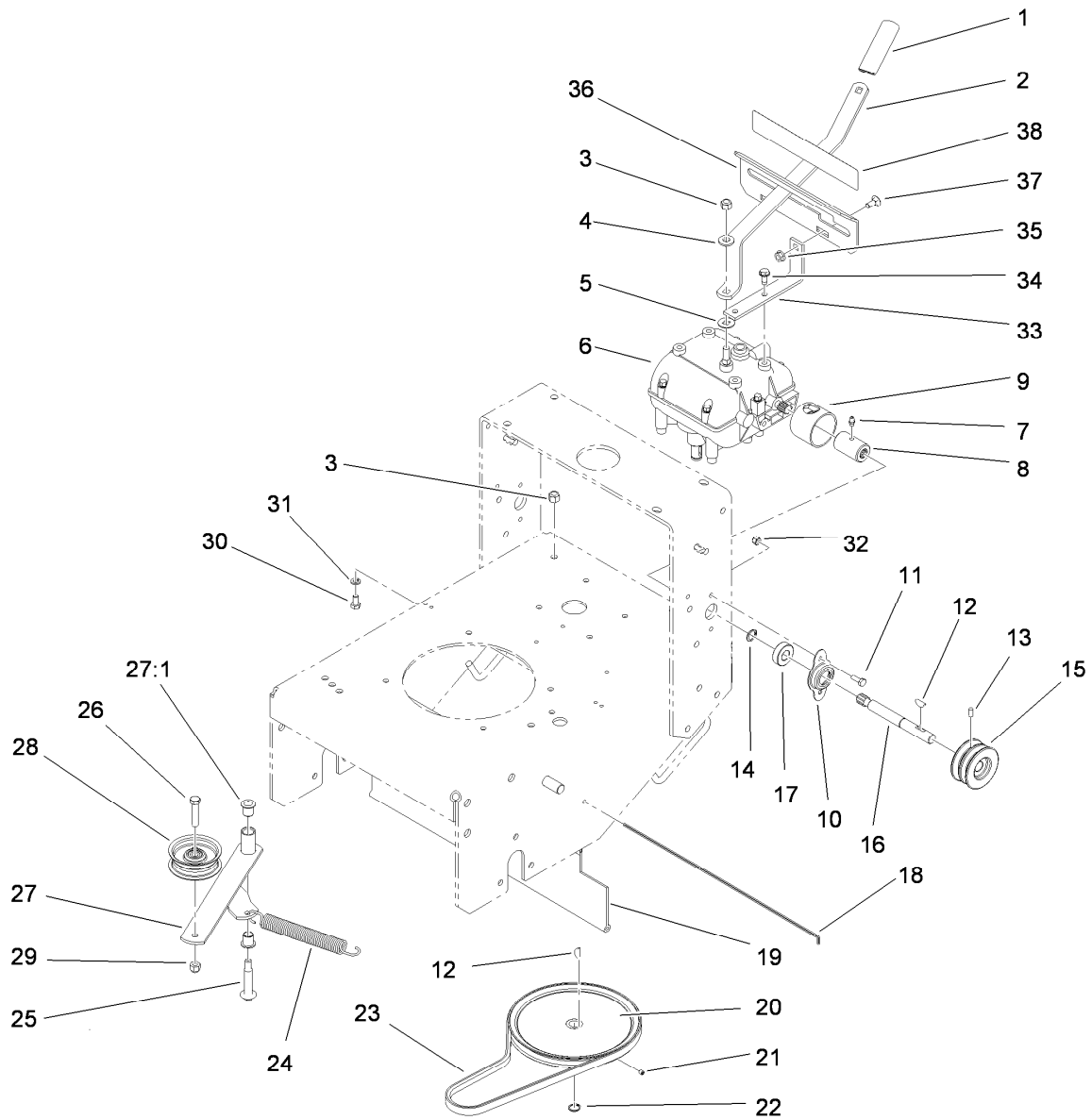

## Transmission Drive Assembly

Ref.	Part Number	Qty.	Description	Ref.	Part Number	Qty.	Description
1	47-1970	1	Grip	21	3245-1	1	Screw-Set, HSH
2	98-3274-03	1	Lever-Shift	22	32120-64	1	Ring-Snap, External
3	3296-6	2	Nut-Lock	23	105-5668	1	V-Belt
4	98-5975	1	Washer-Belleville	24	80-6610	1	Spring-Extension
5	1-323379	1	Washer	25	27-6230	1	Bolt-Wheel
6	1-323500	1	Transmission	26	323-9	1	Screw-HH
7	302-5	2	Fitting-Grease	27	16-7509	1	Lever-Idler
8	1-323680	2	Coupler	27:1	256-155	2	Bushing-Flange
9	51-4220	2	Guard-Coupler	28	62-4540	1	Pulley
10	1-323254	2	Flange-Output	29	3296-39	1	Nut-Lock, NI
11	321-4	4	Screw-HH	30	322-2	4	Screw-HH
12	3257-5	3	Key-Woodruff	31	3253-4	4	Washer-Lock
13	3245-9	2	Screw-Set	32	3296-42	4	Nut-Lock, NI
14	32151-62	2	Ring-Retaining	33	1-323389-03	2	Bracket-Plate, Shift
15	105-2698	2	Pulley-Transmission	34	9264964	4	Screw-HWH, Thread Cut
16	104-1102	2	Shaft-Output	35	32128-20	2	Nut-HF
17	1-323252	2	Bearing-Shaft	36	1-323387-03	1	Plate-Shift
18	95-1529	1	Rod-Shield	37	3230-1	2	Bolt-CARR
19	95-1526	1	Shield-Trailing	38	98-3264	1	Decal-Ground Speed
20	105-5646	1	Pulley-Driven				



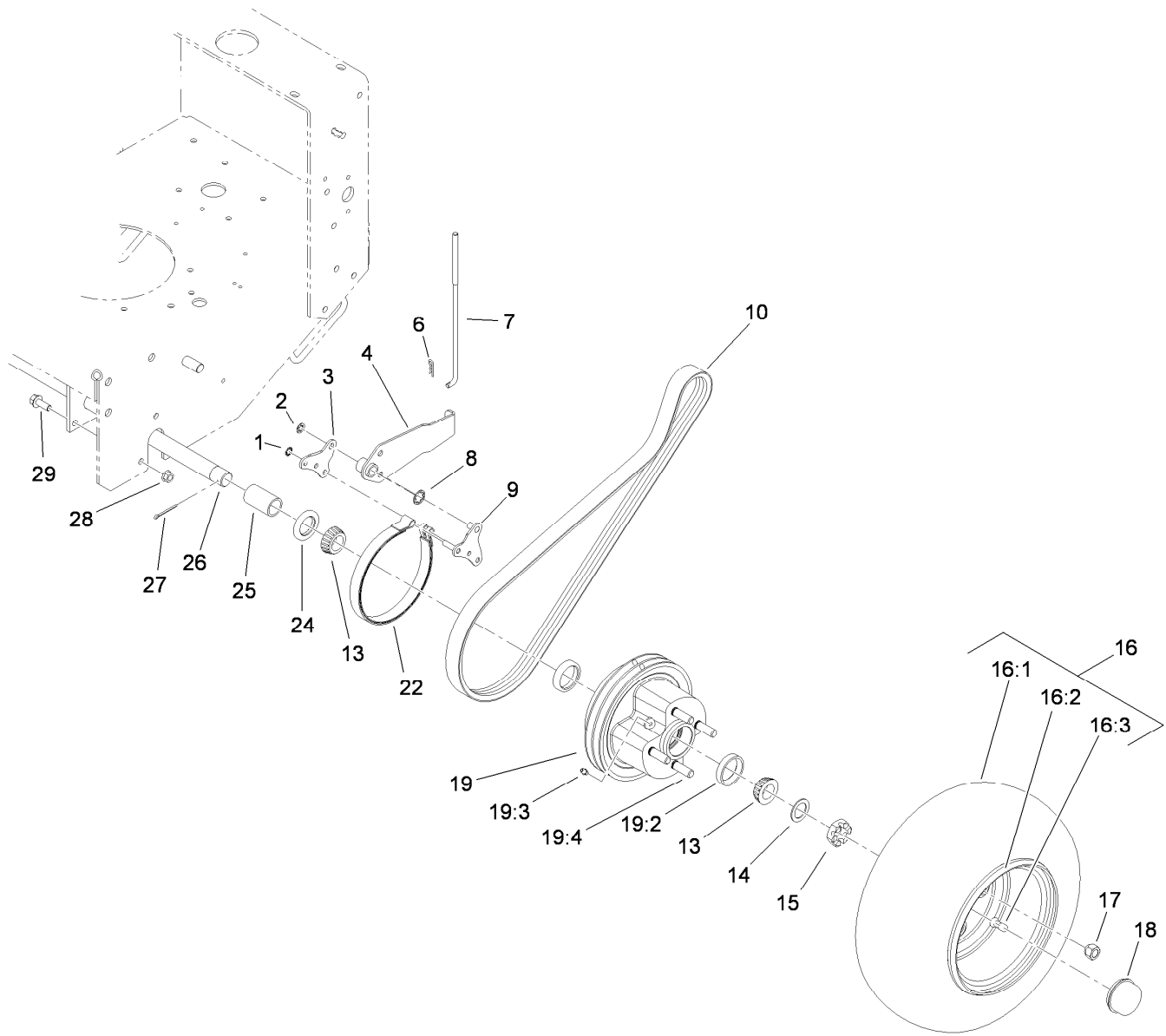

## Wheel Drive and Brake Assembly

Ref.	Part Number	Qty.	Description	Ref.	Part Number	Qty.	Description
1	32151-72	4	Ring-Retaining	16:3	232-27	1	Stem-Valve
2	32151-56	2	Ring-Retaining, External	17	242-50	8	Nut-Lug
3	106-8792	2	Plate-Link, Brake	18	241-119	2	Cap-Dust
4	110-5010-01	2	Brake Arm ASM	19	107-4090	2	Wheel Hub ASM
6	3290-307	2	Pin-Hair	19:2	1-543508	2	Cup-Bearing
7	108-2730	2	Rod-Brake	19:3	302-5	1	Fitting-Grease
8	32151-40	2	Ring-Retaining	19:4	10-6830	4	Stud-Type, Drive
9	106-8773	2	Brake Link ASM	22	1-323262	2	Band-Brake
10	110-5004	2	Belt-V, Banded	24	1-543511	2	Seal-Grease
13	1-543509	4	Bearing-Roller, Tapered	25	110-5006	2	Spacer-Wheel
14	1-523157	2	Washer-Spacer	26	110-4983-01	1	Axle ASM
15	1-809082	2	Nut-SHH	27	1-806800	2	Pin-Cotter
16	106-0892	2	Wheel And Tire ASM	28	32128-21	6	Nut-HF
16:1	104-6322	1	Tire	29	3234-11	6	Screw-HHF
16:2	106-0893	1	Wheel				

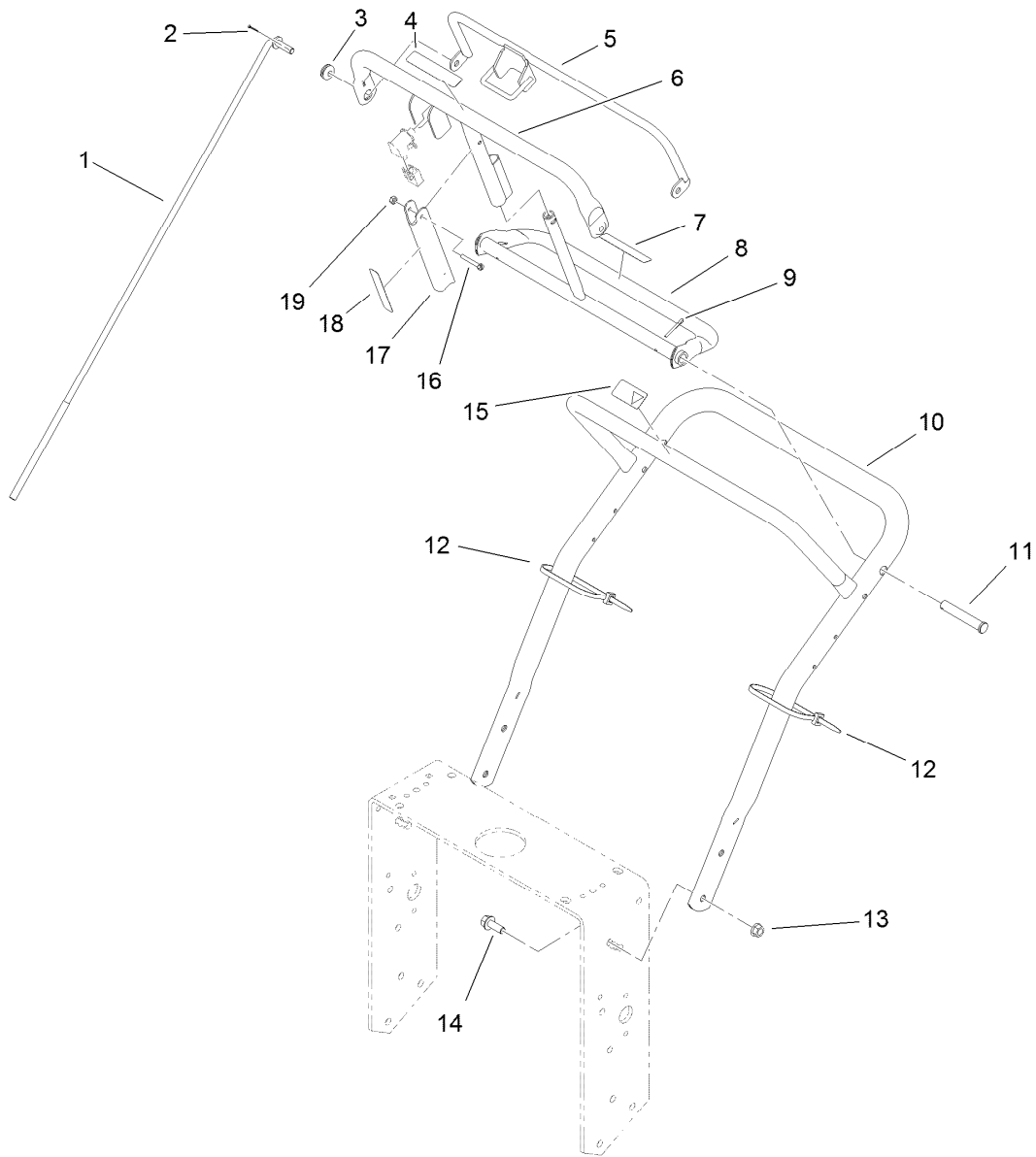

## Handle Assembly

<i>Ref.</i>	<i>Part Number</i>	<i>Qty.</i>	<i>Description</i>	<i>Ref.</i>	<i>Part Number</i>	<i>Qty.</i>	<i>Description</i>
1	105-4677	2	Rod-Control	11	283-55	2	Pin-Clevis
2	3272-4	2	Pin-Cotter	12	3290-378	2	Tie-Cable
3	237-141	2	Grommet-Rubber	13	32128-21	4	Nut-HF
4	93-7298	1	Decal-Bar, Control	14	3234-11	4	Screw-HHF
5	82-7680-03	1	Bail ASM	15	98-4387	1	Decal-Protection, Ear
6	82-7690-03	1	Bar-Control	16	32105-1	1	Screw-SHH
7	93-7299	1	Decal-Reverse	17	51-4850-03	1	Lever-Brake, Parking
8	106-5477-03	1	Control Pivot ASM	18	93-7442	1	Decal-Lever, Parking
9	3272-11	2	Pin-Cotter	19	3296-2	1	Nut-Lock, NI
10	105-3158-01	1	Upper Handle ASM				

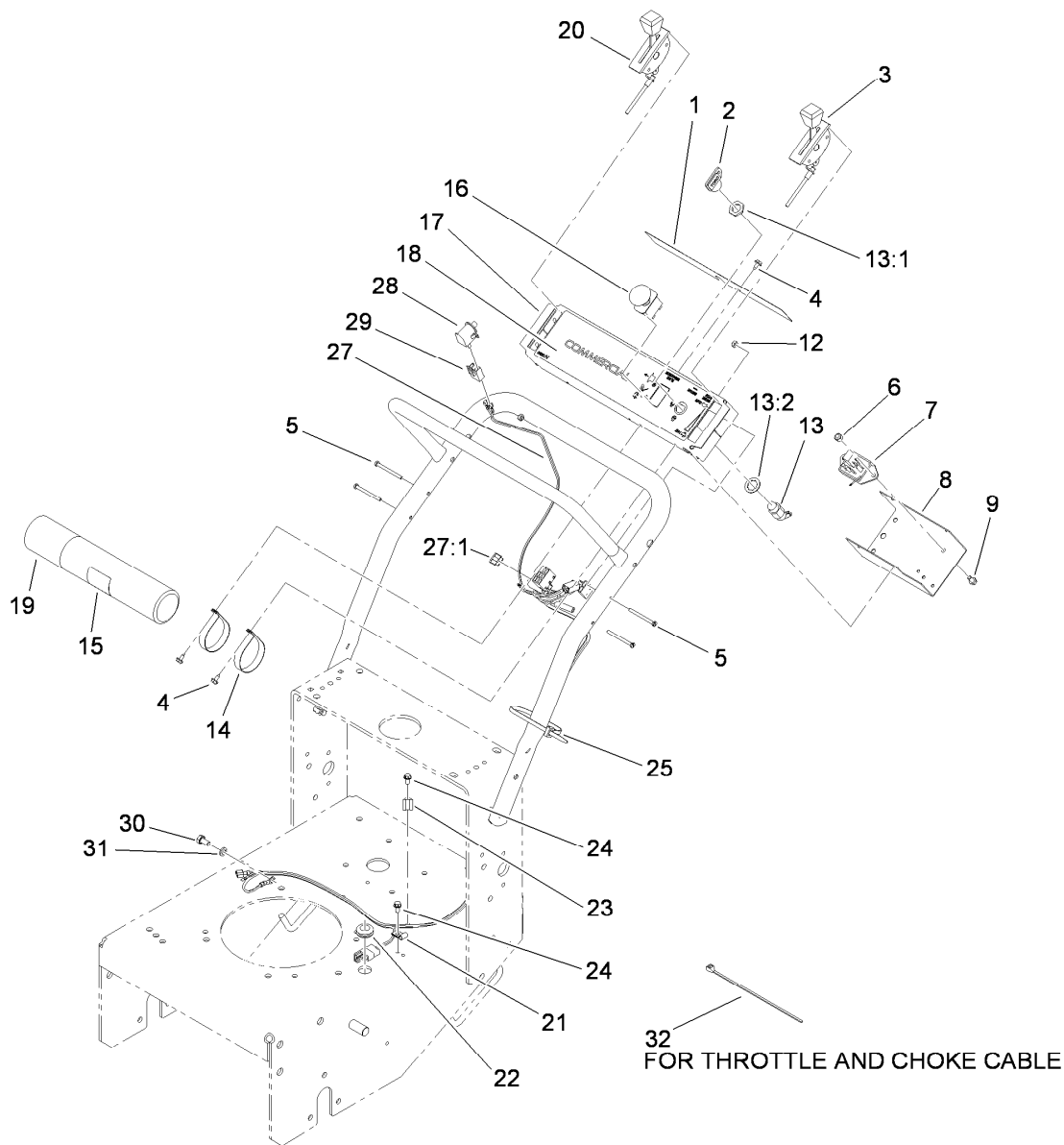

## Control Panel Assembly

<i>Ref.</i>	<i>Part Number</i>	<i>Qty.</i>	<i>Description</i>	<i>Ref.</i>	<i>Part Number</i>	<i>Qty.</i>	<i>Description</i>
1	106-5519	1	Decal-Danger	17	110-4982-03	1	Panel-Control
2	63-8360	1	Key-Ignition	18	110-4972	1	Decal-Panel, Control
3	119-6539	1	Cable-Throttle	19	104-7048	1	Cap-Housing
4	32104-76	4	Screw	20	110-4995	1	Cable-Choke
5	32105-14	4	Screw-SHH	21	2412-72	1	Clip-Closed, Insulated
6	3296-42	1	Nut-Lock, NI	22	112-7069	1	Grommet
7	104-8141	1	Module-Delay	23	2412-134	1	Clamp-R
8	93-1187-03	1	Panel-Bottom	24	32144-4	2	Screw-HWH
9	321-2	1	Screw-HH	25	3290-378	1	Tie-Cable
12	3296-2	4	Nut-Lock, NI	27	119-6508	1	Harness-Wire
13	29-5560	1	Switch-On / Off	27:1	114241	1	Fuse-Blade, 7.5 Amp
13:1	218-461	1	Nut-HH	28	82-2190	1	Switch-Bail
13:2	3254-5	1	Washer-Tooth, Internal	29	218-595	1	Connector-Body
14	2412-120	2	R-Clamp	30	33114-016	1	Screw-HH
15	104-7050	1	Tube-Manual	31	3253-4	1	Washer-Lock
16	104-8140	1	Switch-PTO	32	1-303287	1	Tie-Cable

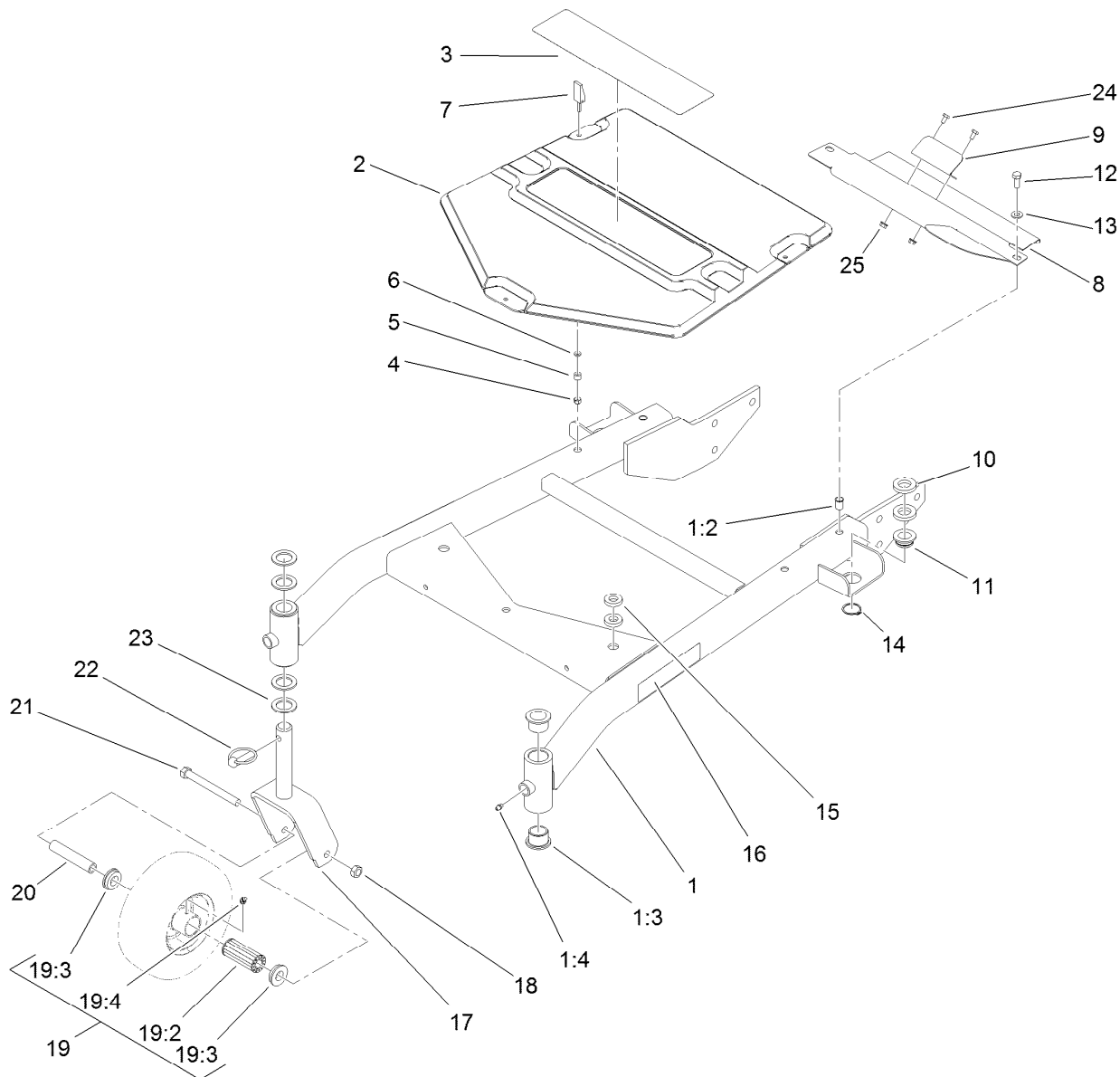

## Carrier Frame Assembly

Ref.	Part Number	Qty.	Description
1	110-6960	1	Carrier Frame ASM
1:2	32148-9	2	Insert-Nut
1:3	94-1291	4	Bushing
1:4	302-5	2	Fitting-Grease
2	110-6970	1	Cover-Frame, Carrier
3	112-9710	1	Decal
4	1-804254	3	Nut-Lock, HH
5	106-6778	3	Bushing-Latch, Swell
6	99-3058	3	Washer
7	106-6777	3	Handle-Latch, Swell
8	119-7858-01	1	Shield-Belt
9	119-7859-01	1	Shield-Heat, Manifold
10	104-1105	4	Spacer-Support, Deck
11	1-513336	2	Bushing-Deck
12	323-6	2	Screw-HH
13	3256-24	2	Washer-Flat

Ref.	Part Number	Qty.	Description
14	32120-33	2	Ring-Retaining
15	1-323539	4	Spacer
16	106-0636	2	Decal
17	105-3159-01	2	Castor Fork ASM
18	32153-5	2	Nut-Hex
19	110-5024	2	Wheel And Tire ASM
19:2	112-7066	1	Bearing-Roller
19:3	1-513810	2	Bushing
19:4	302-61	1	Fitting-Grease
20	100-6453	2	Bushing-Spanner
21	325-19	2	Screw-HH
22	283-71	2	Pin-Lynch
23	3-6781	8	Washer-Thrust
24	321-2	2	Screw-HH
25	32128-32	2	Nut-HHF

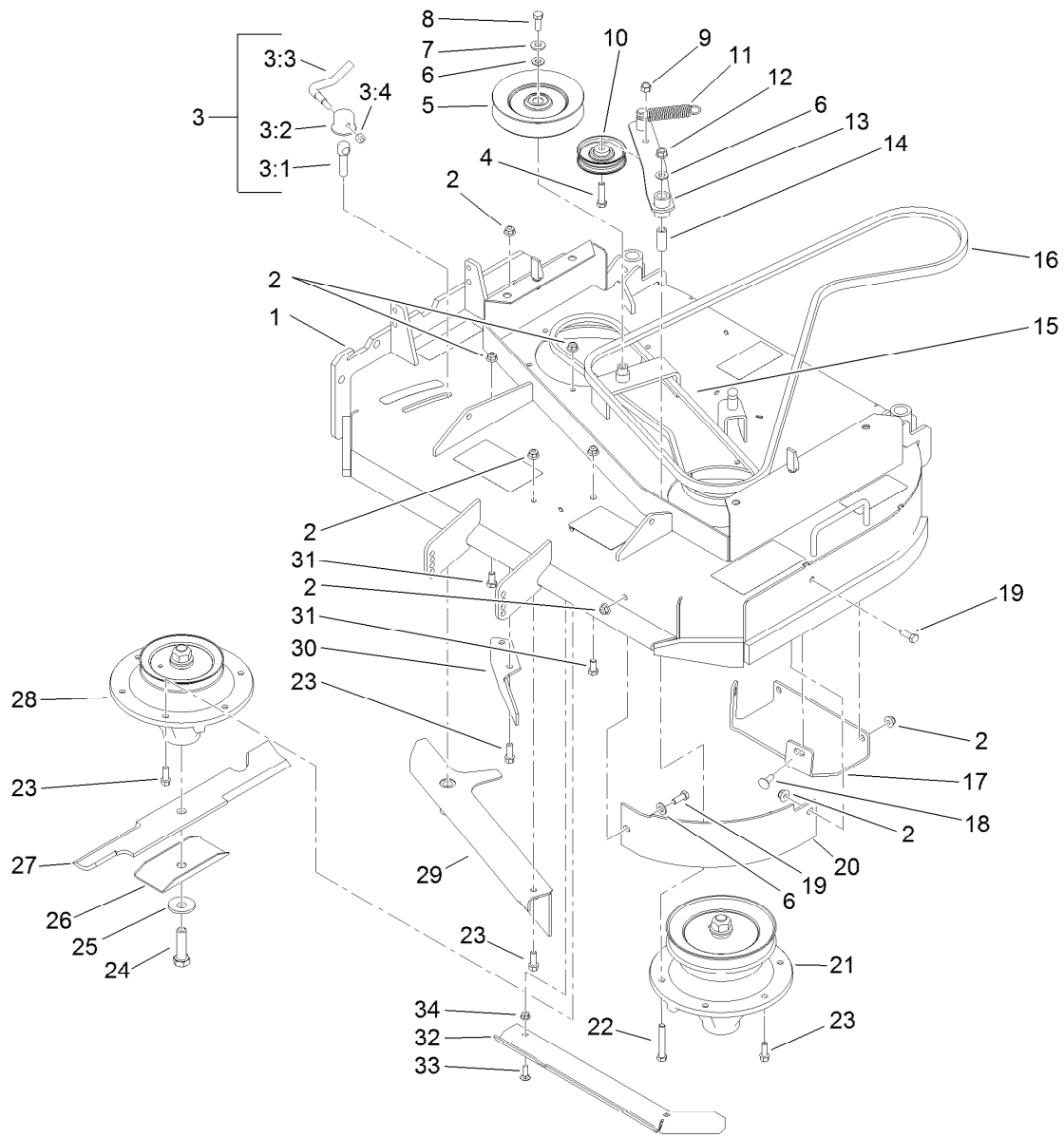

## Deck Drive and Baffle Assembly

Ref.	Part Number	Qty.	Description
1	115-4230	1	Deck And Decal ASM
2	104-8301	22	Nut-Flange, NI
3	107-1664	1	Lever ASM
3:1	106-3239	1	Screw-Lock
3:2	107-1644	1	Cap-Lock
3:3	106-3241	1	Lever-Lock
3:4	3296-29	1	Nut-Lock, NI
4	323-8	1	Screw-HH
5	1-633166	1	Pulley-Idler
6	3256-24	2	Washer-Flat
7	98-5975	1	Washer-Belleville
8	323-6	1	Screw-HH
9	3296-39	1	Nut-Lock, NI
10	51-3660	1	Pulley-Idler
11	105-2673	1	Spring-Extension
12	32128-21	1	Nut-HF
13	105-0889	1	Idler Arm ASM
14	51-3641	1	Sleeve-Pivot, Idler
15	110-6953	1	Belt-V

Ref.	Part Number	Qty.	Description
16	105-0886	1	Belt-Drive, PTO
17	110-2037-01	1	Plate-Skid
18	3231-2	4	Screw-CARR
19	323-6	2	Screw-HH
20	110-6903-03	1	Baffle-Front, LH
21	110-6950	1	Spindle ASM
22	323-12	1	Screw-HH
23	92-1624	14	Screw-HWH
24	51-4060	2	Screw-Blade
25	103-0865	2	Washer-Blade Bolt, Heavy
26	108-2727	2	Stiffener-Blade
27	105-7781-03	2	Blade-18 Inch (Hi Flow)
28	110-0728	1	Spindle ASM
29	110-6955-03	1	Adjust Baffle ASM
30	110-0754-01	1	Baffle-Discharge
31	323-4	2	Screw-HH
32	119-7839-01	1	Extender-Deck
33	3230-2	2	Bolt-CARR
34	104-8300	2	Nut-Flange, NI

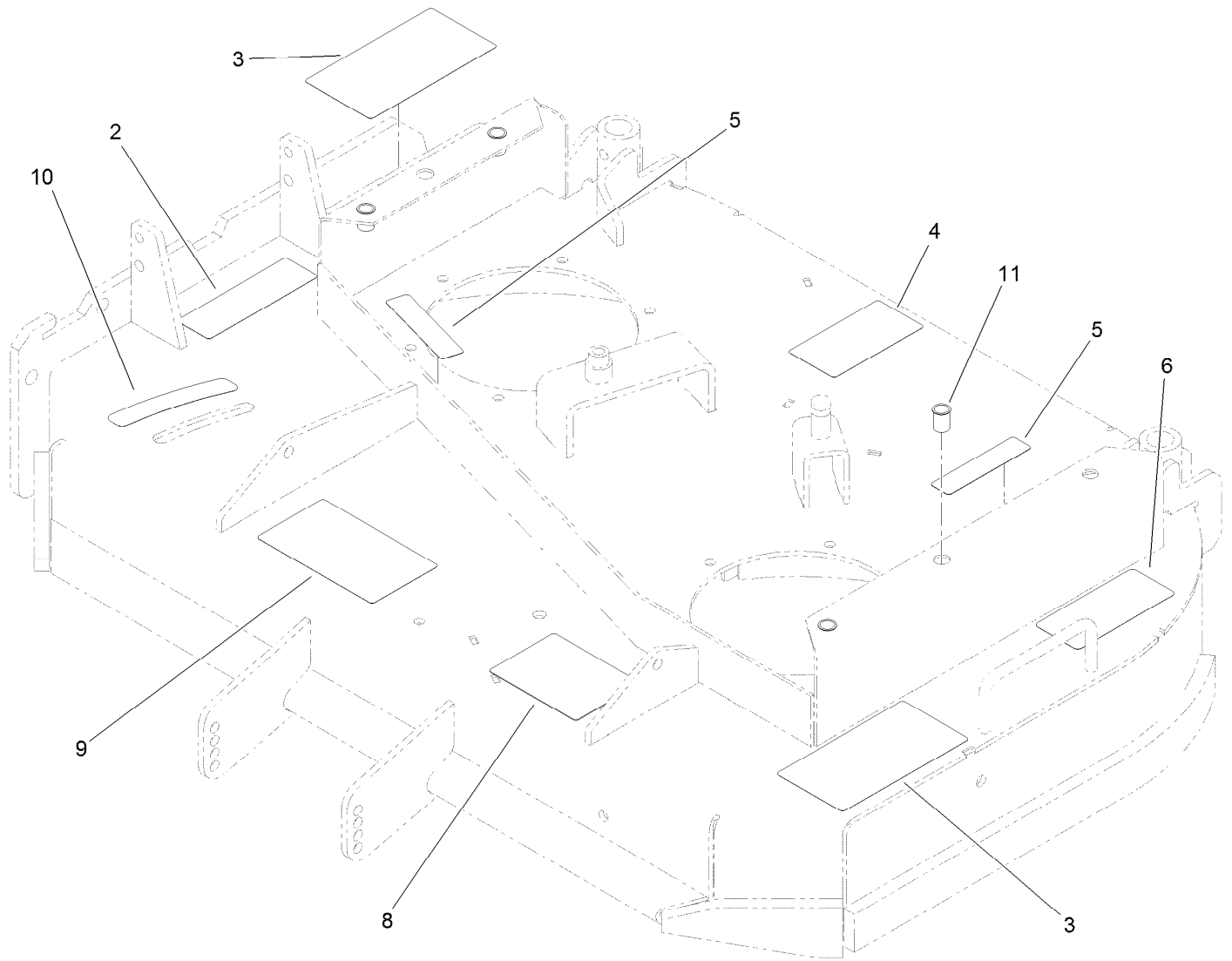

## Deck Decal Assembly No. 115-4230

<i>Ref.</i>	<i>Part Number</i>	<i>Qty.</i>	<i>Description</i>
2	93-7828	1	Decal-Warning, Deflector
3	114-3449	2	Decal-Danger
4	104-8185	1	Decal
5	98-1977	2	Decal-Warning
6	93-7818	1	Decal-Torque, Blade Bolt
8	99-8939	1	Decal-Anti Scalp
9	110-2068	1	Decal-Adjustment, Baffle
10	110-2067	1	Decal-Setting, Baffle
11	32148-9	4	Insert-Nut

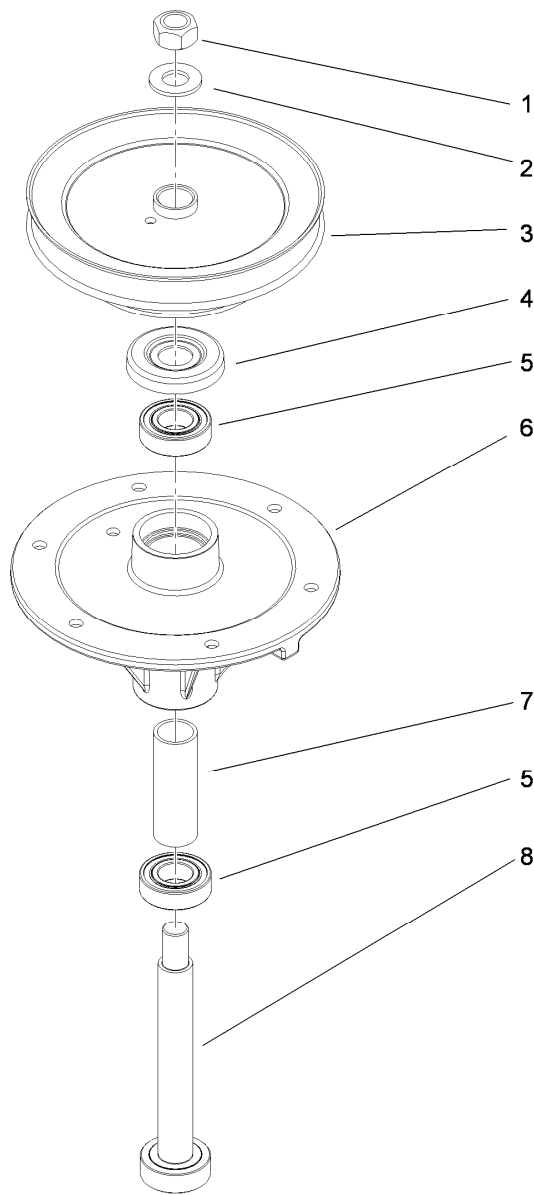

## Spindle Assembly No. 110-6950

<i>Ref.</i>	<i>Part Number</i>	<i>Qty.</i>	<i>Description</i>
1	3219-7	1	Nut-Hex
2	7-4150	1	Washer
3	110-6951	1	Pulley And Hub ASM
4	106-0873	1	Shield-Bearing
5	116-0720	2	Bearing-Ball
6	108-6696	1	Housing-Spindle
7	110-0727	1	Spacer-Bearing
8	110-0725	1	Shaft-Spindle

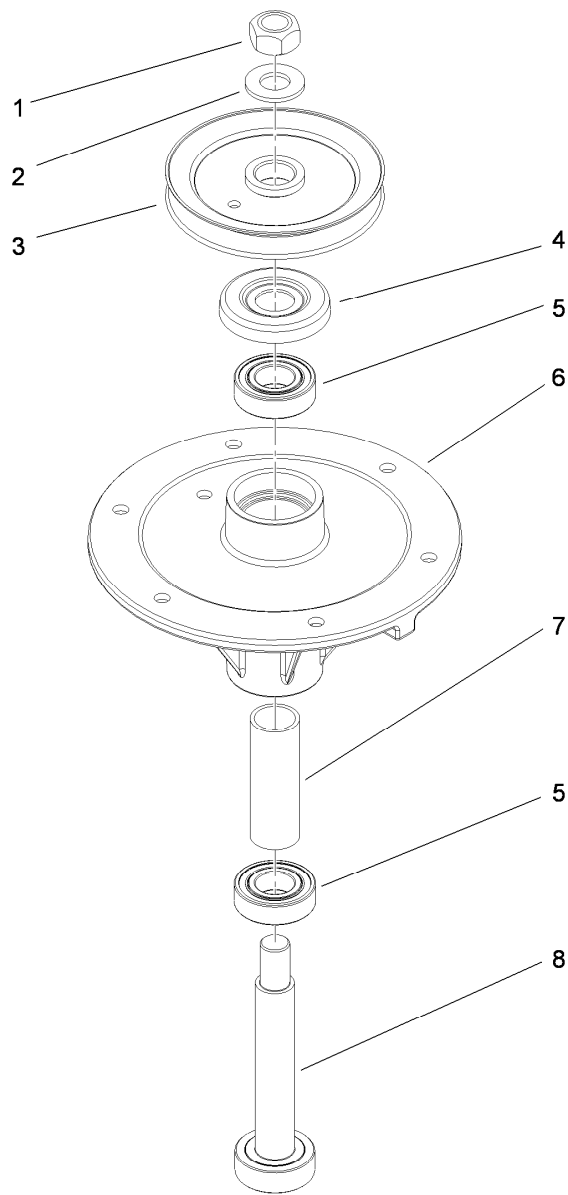

## Spindle Assembly No. 110-0728

<i>Ref.</i>	<i>Part Number</i>	<i>Qty.</i>	<i>Description</i>
1	3219-7	1	Nut-Hex
2	7-4150	1	Washer
3	104-1181	1	Pulley ASM
4	106-0873	1	Shield-Bearing
5	116-0720	2	Bearing-Ball
6	108-6696	1	Housing-Spindle
7	110-0727	1	Spacer-Bearing
8	110-0726	1	Shaft-Spindle



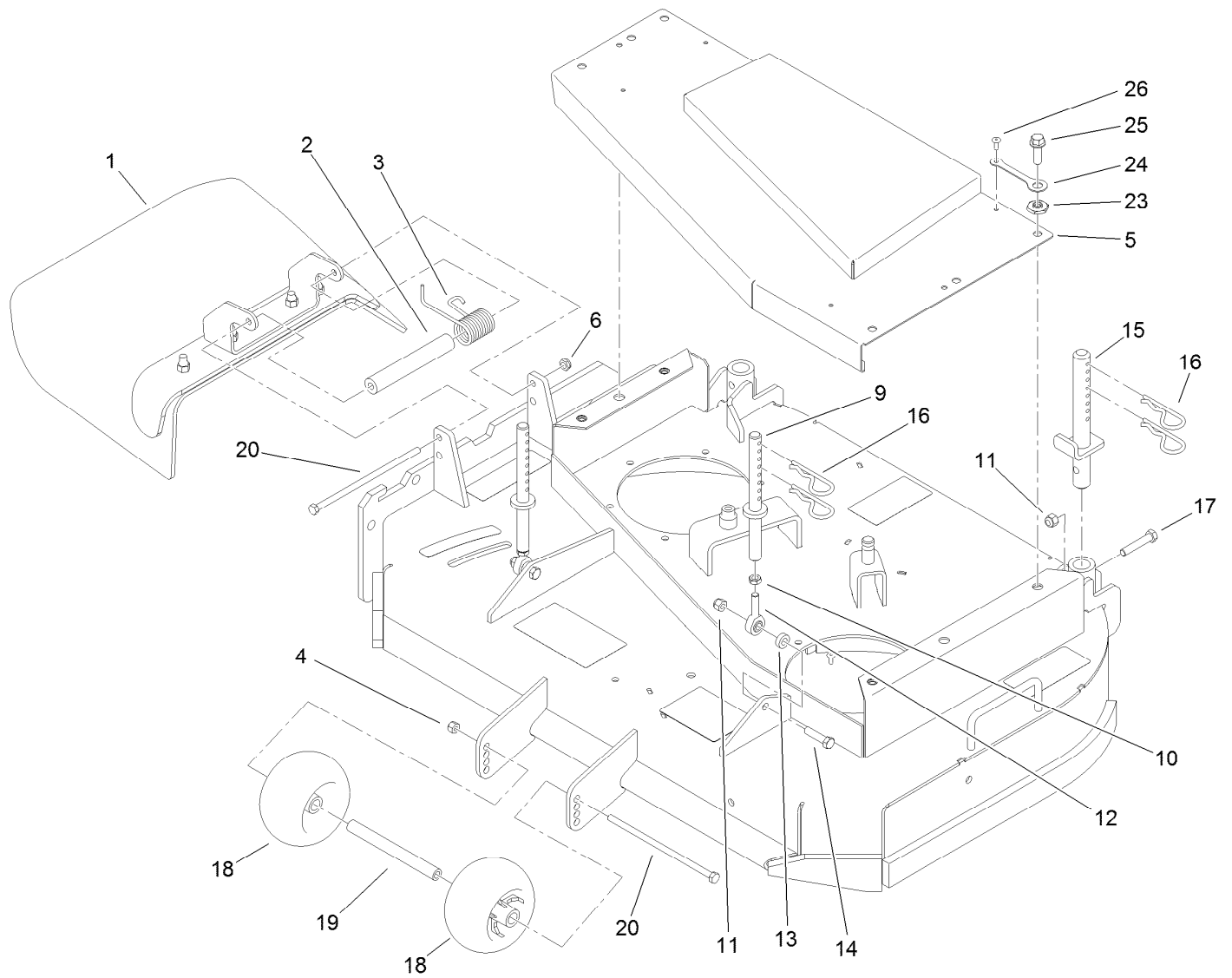

## Deck Deflector, Roller and Cover Assembly

<i>Ref.</i>	<i>Part Number</i>	<i>Qty.</i>	<i>Description</i>	<i>Ref.</i>	<i>Part Number</i>	<i>Qty.</i>	<i>Description</i>
1	110-0790	1	Deflector ASM	14	323-8	2	Screw-HH
2	105-4622	1	Spacer	15	110-2086	2	Rear Pin ASM
3	104-8554	1	Spring-Torsion	16	3290-256	6	Pin-Hair
4	3296-29	1	Nut-Lock, NI	17	323-10	2	Screw-HH
5	119-6512-01	1	Deck Belt Cover ASM	18	1-603299	2	Roller-Scalp, Anti
6	3296-47	1	Nut-Lock, NI	19	98-5967	1	Spacer-Wheel
9	108-2674	2	Front Pin ASM	20	322-50	2	Screw-HH
10	3220-3	2	Nut-HJ	23	117-8347	4	Nut-Shoulder
11	3296-39	4	Nut-Lock, NI	24	117-8339	4	Lanyard-3 Inch
12	1-613204	2	Balljoint	25	3234-24	4	Screw-HHF
13	104-1156	2	Spacer	26	114439	4	Rivet-Pop

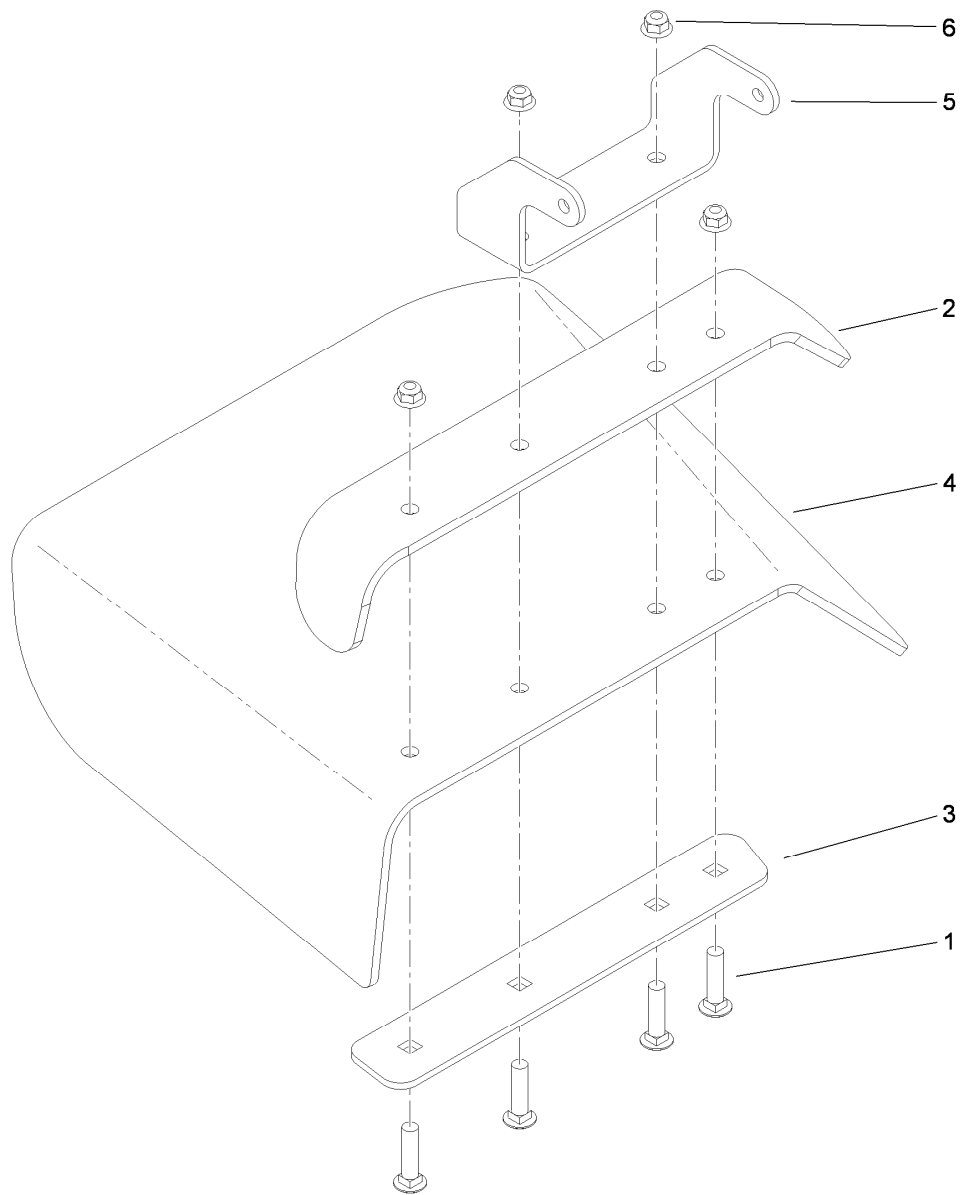

## Deflector Assembly No. 110-0790

<i>Ref.</i>	<i>Part Number</i>	<i>Qty.</i>	<i>Description</i>
1	3231-4	4	Screw-CARR
2	110-0792-01	1	Deflector
3	110-0793-03	1	Strap-Discharge
4	110-0791	1	Deflector-Rubber
5	107-4164-01	1	Bracket-Mounting, Deflector
6	104-8301	4	Nut-Flange, NI

# Attachments and Accessories

## For 30070 Commercial Walk-Behind Mower 16HP, T-Bar, Gear Drive with 91cm TURBO FORCE Cutting Unit

<b>Product Name</b>	<b>Model/Part</b>
Blade-Recycler, 18 inch .....	105-7779-03
Blade-Med Flow, 18 inch.....	105-7794-03
Blade-Low Flow, 18 inch .....	105-7795-03
Blade-Atomic, 18 inch.....	105-7796-03
Blade-Hi Flow, 18 inch (6 Pack) .....	108-1117
Blade-Atomic, 18 inch (6 Pack).....	108-1118
Blade-Lo Flow, 18 inch (6 Pack) .....	110-0406
Blade-Recycler, 18 inch (6 Pack).....	110-0408
Blade-Med Flow, 18 inch (6 Pack) .....	110-0409
36 inch Bagger Enhancement Kit.....	110-2026
36 inch Recycler Kit .....	110-2080
Weight-Cast.....	112-7059-01
Operator-Controlled Discharge Chute Kit .....	115-4190
Soft Bag (3 Bushel).....	30104
Tru Trak Sulky.....	30110



**Count on it.**