



Count on it.

Parts Catalog

**Commercial Walk-Behind Mower
Fixed Deck, Pistol Grip, Gear Drive with 48in
TURBO FORCE® Cutting Unit**

Model No. 30638—Serial No. 311000001 and Up

Ordering Replacement Parts

To order replacement parts, please supply the part number, the quantity, and the description of each part desired.

Understanding Reference Numbers

Each identified part in an illustration has a reference number. The reference number for a part also appears in the parts list, along with other information about the part.

This catalog uses two special reference number formats, one to indicate parts in a service assembly and another to indicate the quantity of a given part in an illustration.

Service Assembly Reference Numbers

Parts in service assemblies have reference numbers in the form a:b. The a represents the reference number of the entire service assembly and the b represents a sequential number unique to each part within the service assembly.

For example, a wheel assembly might be identified by reference number 6, the tire by 6:1, the valve by 6:2, and the wheel by 6:3. When you order the assembly identified by reference number 6, you receive all parts identified by reference numbers 6:1, 6:2, and 6:3. However, you may also order any part individually. Reference numbers of this type appear in illustration and in parts lists.

Reference Numbers Indicating Quantity

In an illustration, if a reference number indicates more than one part, the reference number has the form nX y. The n represents the quantity of the part, the X is the multiplication symbol, and the y represents the reference number.

For example, in an illustration, the reference number 2X 37 means that two of the parts identified by reference number 37 are indicated.

List of Abbreviations

AR: as required

ASM: assembly

BBC: blade brake control

BHTF: button head thread forming

CARR: carriage

CCW: counter clockwise

CW: clockwise

DEG: degrees

DPA: Dual Point Adjustment

ECM: electronic control module

EXT: external

FH: flat head

GA: gauge

HD: heavy-duty

HF: hex flange

HH: hex head

HHF: hex head flange

HHFTF: hex head flange thread forming

HJ: hex jam

HLH: hex lag head

HOC: height-of-cut

HSBH: hex socket button head

HSFH: hex socket flat head

HSH: hex socket head

HWH: hex washer head

HWHTF: hex washer head thread forming

HYD: hydraulic

LH: left hand

LP: Liquid Propane

NI: nylon insert

NPTF: national pipe thread fine

PFH: phillips flat head

PPH: phillips pan head

PPHTF: phillips pan head thread forming

PRH: phillips round head

PTH: phillips truss head

PTO: power-take-off

RH: right hand

ROPS: roll-over protection system

RRB: rear roller brush

SFH: slotted fillister head

SHH: slotted hex head

SHWH: slotted hex washer head

SPH: slotted pan head

SQH: square head

SRH: slotted round head

STD: standard

TAP: self tapping

TTH: torx truss head

Contents

Engine and Exhaust Assembly.....	4
Fuel System Assembly	5
Frame and Transmission Assembly	6
Drive Wheel and Brake Assembly	8
Handle Control Assembly	10
Handle Assembly	11
Deck Assembly	12
Deck Decal Assembly No. 110-4909.....	13
Deflector Assembly No. 110-0758.....	14
Sheave, Spindle and Blade Assembly	15
Idler Assembly	16
Caster Assembly	17
Attachments and Accessories	18

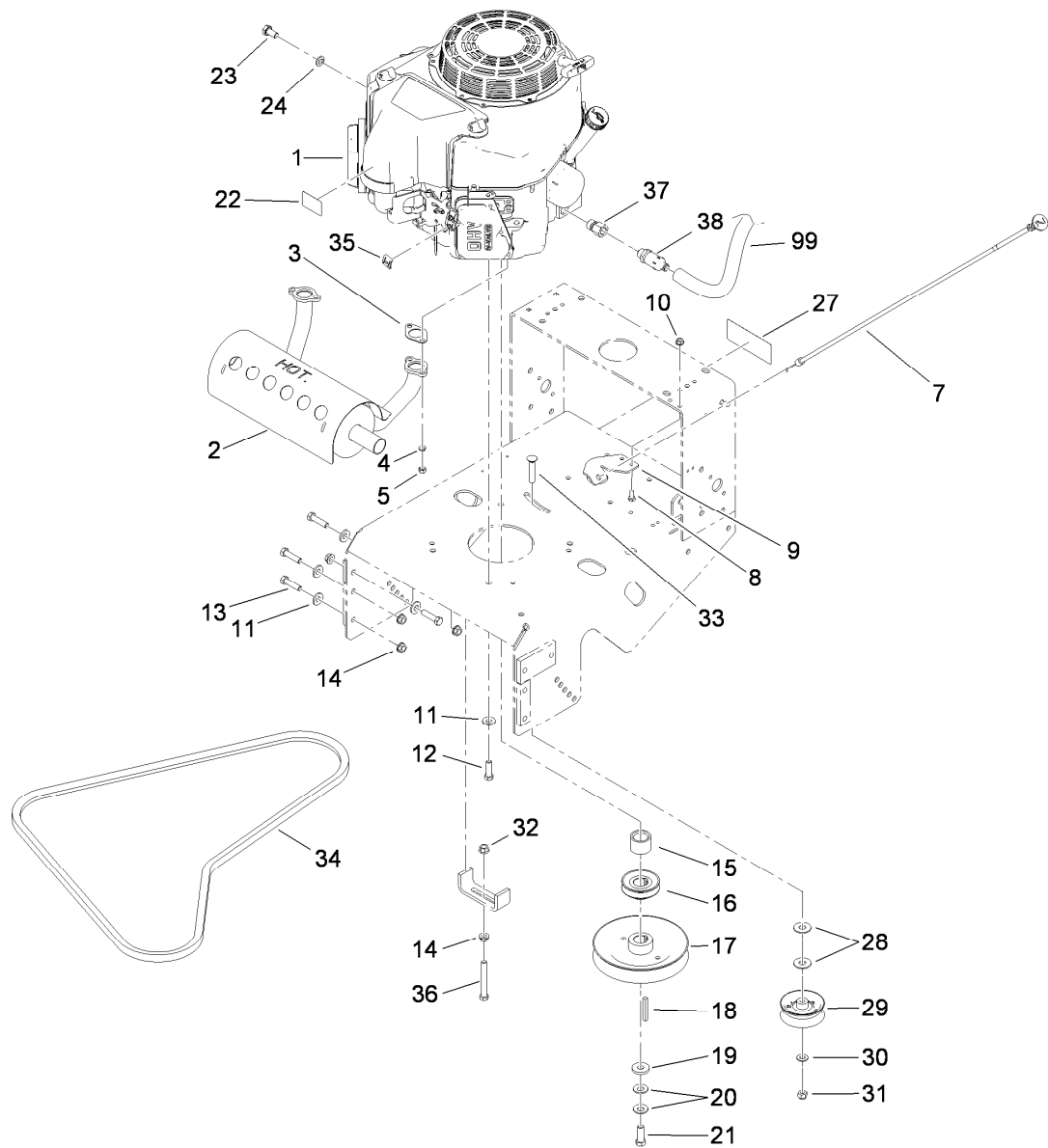

Engine and Exhaust Assembly

Ref.	Part Number	Qty.	Description
1		1	Engine-Kawasaki, Fs481V-As06 ●■
2	116-4396	1	Muffler-Horizontal, Offset
3	1-653313	2	Gasket-Exhaust
4	114-3550	4	Washer-Lock, Spring
5	114-3549	4	Nut
7	103-1796	1	Cable-Choke
8	321-3	2	Screw-HH
9	103-1797-01	1	Bracket-Cable, Choke
10	32128-33	2	Nut-HF
11	98-5975	12	Washer-Belleville
12	323-7	4	Screw-HH
13	323-8	8	Screw-HH
14	3290-357	9	Nut-HHF, Whiz
15	1-633453	1	Spacer-Clutch
16	103-1666	1	Sheave-Transmission
17	110-4890	1	Pulley ASM
18	103-4177	1	Key
19	1-373034	1	Washer

Ref.	Part Number	Qty.	Description
20	1-603610	2	Washer-Spring
21	116-3702	1	Screw-HH
22	103-2076	1	Decal-Caution
23	33114-016	1	Screw-HH
24	3253-4	1	Washer-Lock
27	98-0776	1	Decal-Caution
28	3256-5	2	Washer-Flat
29	1-323285	1	Pulley-Idler, Flat
30	3256-24	1	Washer-Flat
31	3296-39	1	Nut-Lock, NI
32	32128-21	1	Nut-HF
33	3231-6	1	Screw-CARR
34	110-0543	1	Belt-V
35	81-1690	1	Clamp-Cable
36	323-14	1	Screw-HH
37	103-1966	1	Adapter
38	92-6877	1	Valve-Drain, Oil
99	103-1964	1	Hose-Drain, Oil

● Not serviced separately

■ Obtain parts from www.kawpowerepc.com

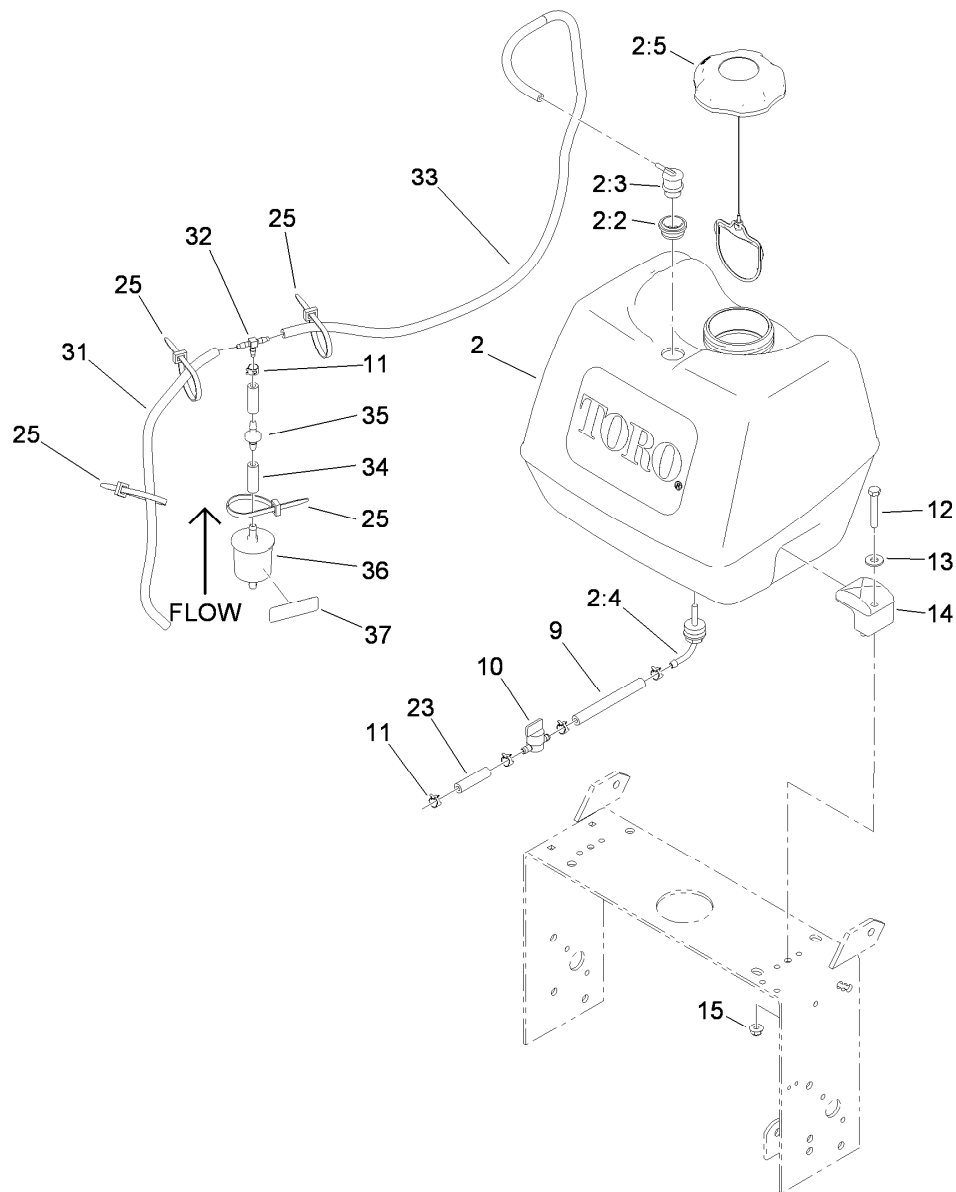

Fuel System Assembly

Ref.	Part Number	Qty.	Description	Ref.	Part Number	Qty.	Description
2	119-7899	1	Fuel Tank ASM	15	104-8300	2	Nut-Flange, NI
2:2	119-6549	1	Grommet-Valve, Roll Over	23	99-9415	1	Hose-Fuel
2:3	114-0285	1	Valve-Rollover	25	3290-378	4	Tie-Cable
2:4	103-2605	1	Fitting-Fuel, Bulkhead	31	115-7872	1	Hose-Fuel
2:5	115-4465	1	Cap-Fuel, Ratcheting	32	120-2234	1	Fitting-Tee
9	109-0650	1	Hose-Fuel	33	116-4346	1	Hose-Emissions
10	1-603770	1	Valve-Fuel	34	106-9492	2	Hose-Fuel
11	2412-98	5	Clamp	35	99-5000	1	Valve-Check, Fuel
12	322-10	2	Screw-HH	36	120-2235	1	Filter-Air
13	3256-3	2	Washer-Flat	37	116-4769	1	Decal-Filter, Emissions
14	107-4543	2	Clamp				

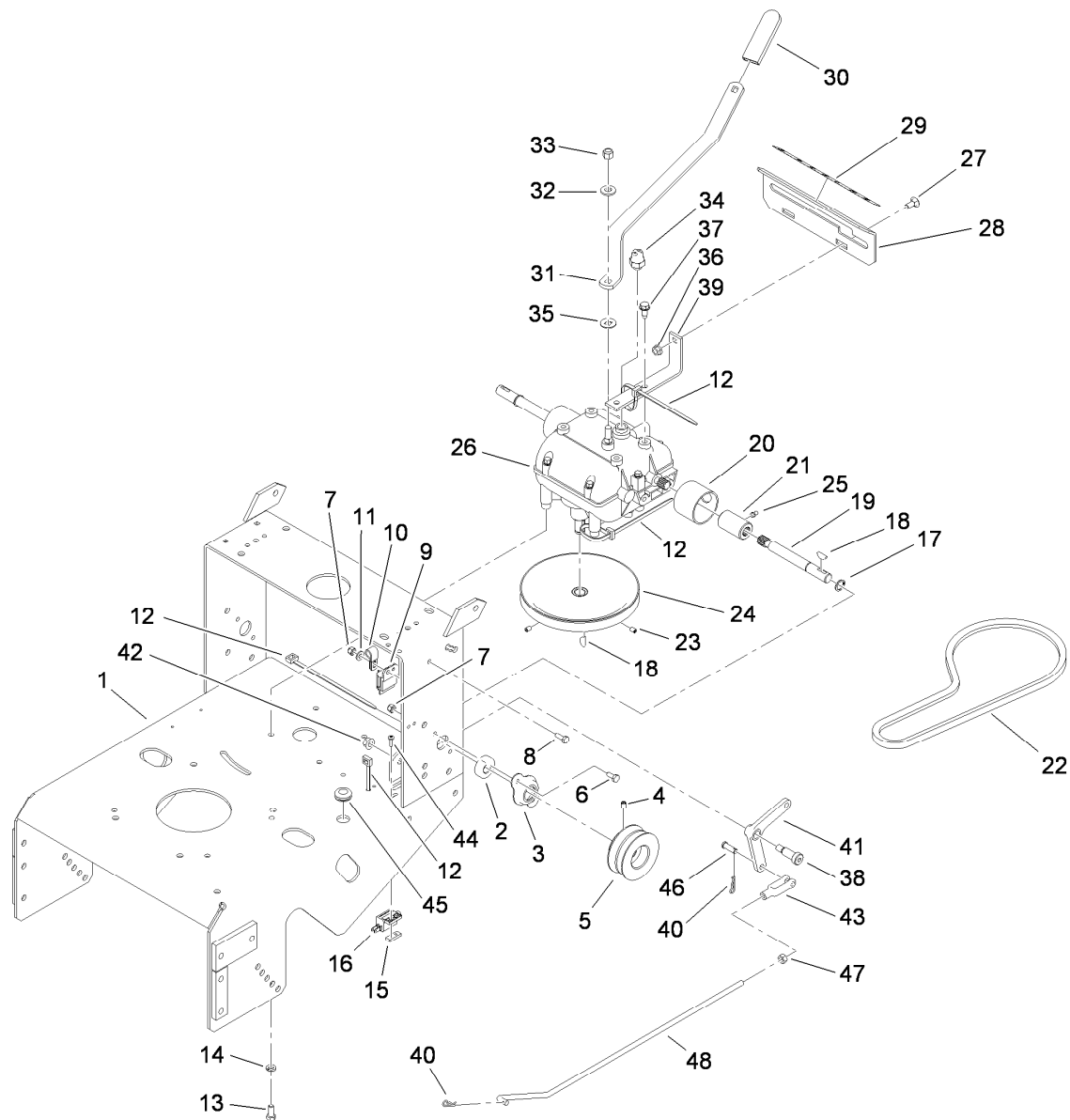

Frame and Transmission Assembly

Ref.	Part Number	Qty.	Description	Ref.	Part Number	Qty.	Description
1	117-3521-01	1	Gear Frame ASM	22	1-323630	1	V-Belt
2	1-323252	2	Bearing-Shaft	23	3245-41	2	Screw-HSH
3	1-323254	2	Flange-Output	24	1-323278	1	Sheave-Transmission
4	1-803310	2	Screw-Set	25	302-19	2	Fitting-Grease
5	103-6511	2	Sheave-Transmission	26	1-323500	1	Transmission
6	321-3	4	Screw-HH	27	3230-1	2	Bolt-CARR
7	3296-42	5	Nut-Lock, NI	28	1-323387-03	1	Plate-Shift
8	321-4	1	Screw-HH	29	105-4104	1	Decal-Speed, Ground
9	1-323430	1	Module-Interlock	30	1-303020	1	Grip-Lever
10	1-513762	1	Clip-Loom	31	98-3274-03	1	Lever-Shift
11	3256-22	1	Washer-Flat	32	98-5975	1	Washer-Belleville
12	1-303335	4	Tie-Plastic	33	3296-6	1	Nut-Lock
13	322-3	4	Screw-HH	34	1-303282	1	Switch-Start, Neutral
14	1-805005	4	Washer-Lock	35	1-323379	1	Washer
15	1-633181	1	Plate-Tapped	36	32128-20	2	Nut-HF
16	1-513051	1	Switch-Open, Normally	37	9264964	4	Screw-HWH, Thread Cut
17	32151-62	2	Ring-Retaining	38	1-603403	1	Bolt-Shoulder
18	3257-5	3	Key-Woodruff	39	1-323389-03	2	Bracket-Plate, Shift
19	1-323502	2	Shaft-Transmission	40	1-806003	2	Pin-Cotter, Hair
20	51-4220	2	Guard-Coupler	41	1-303186	1	Bellcrank
21	1-323680	2	Coupler	42	32128-21	1	Nut-HF

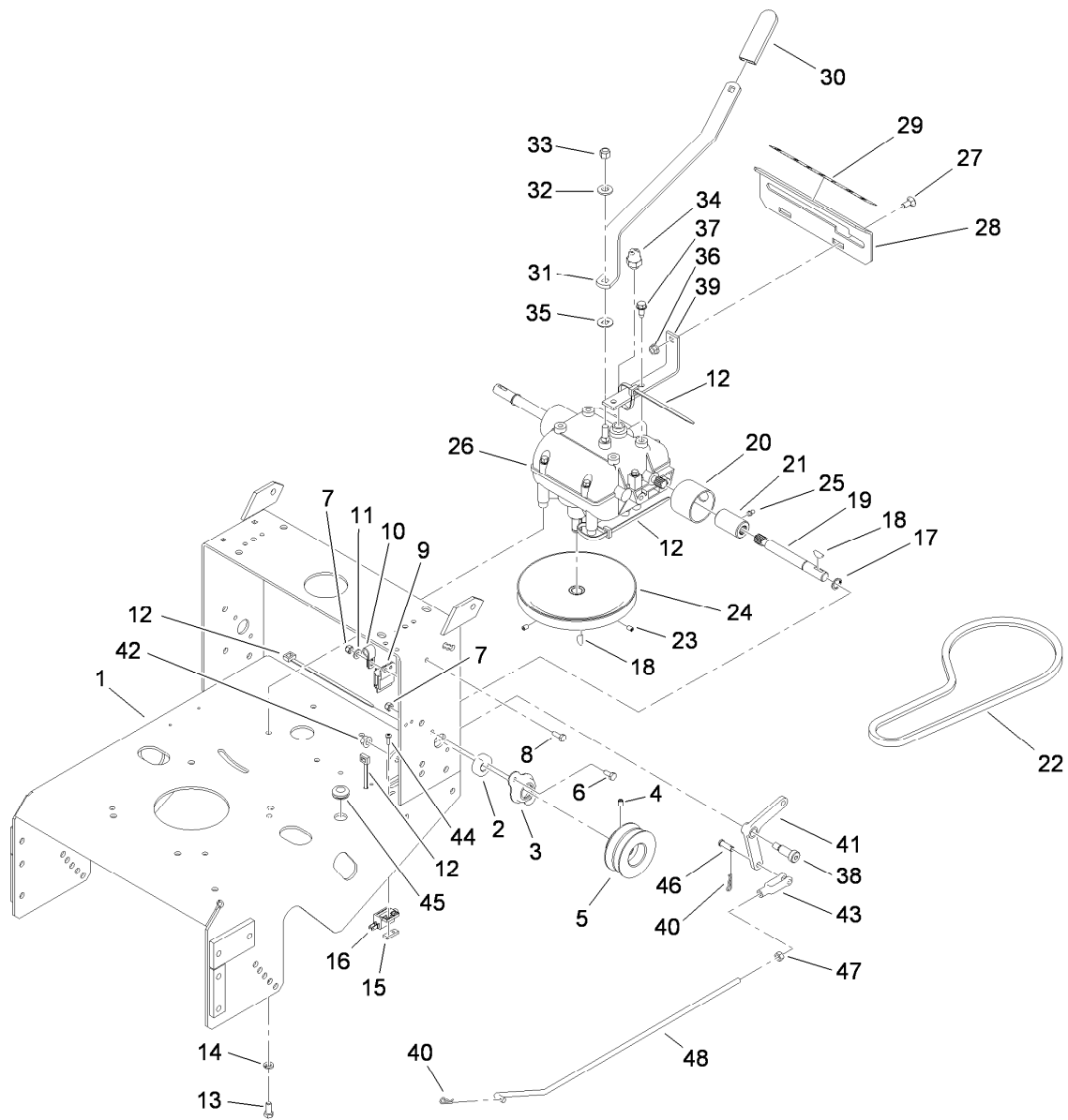

Frame and Transmission Assembly (continued)

Ref.	Part Number	Qty.	Description
43	1-303105	1	Yoke-Adjustable
44	3290-500	2	Screw-PPH
45	1-543296	1	Grommet

Ref.	Part Number	Qty.	Description
46	1-808280	1	Pin-Clevis
47	3219-2	1	Nut-Hex
48	1-323303	1	Linkage-Arm

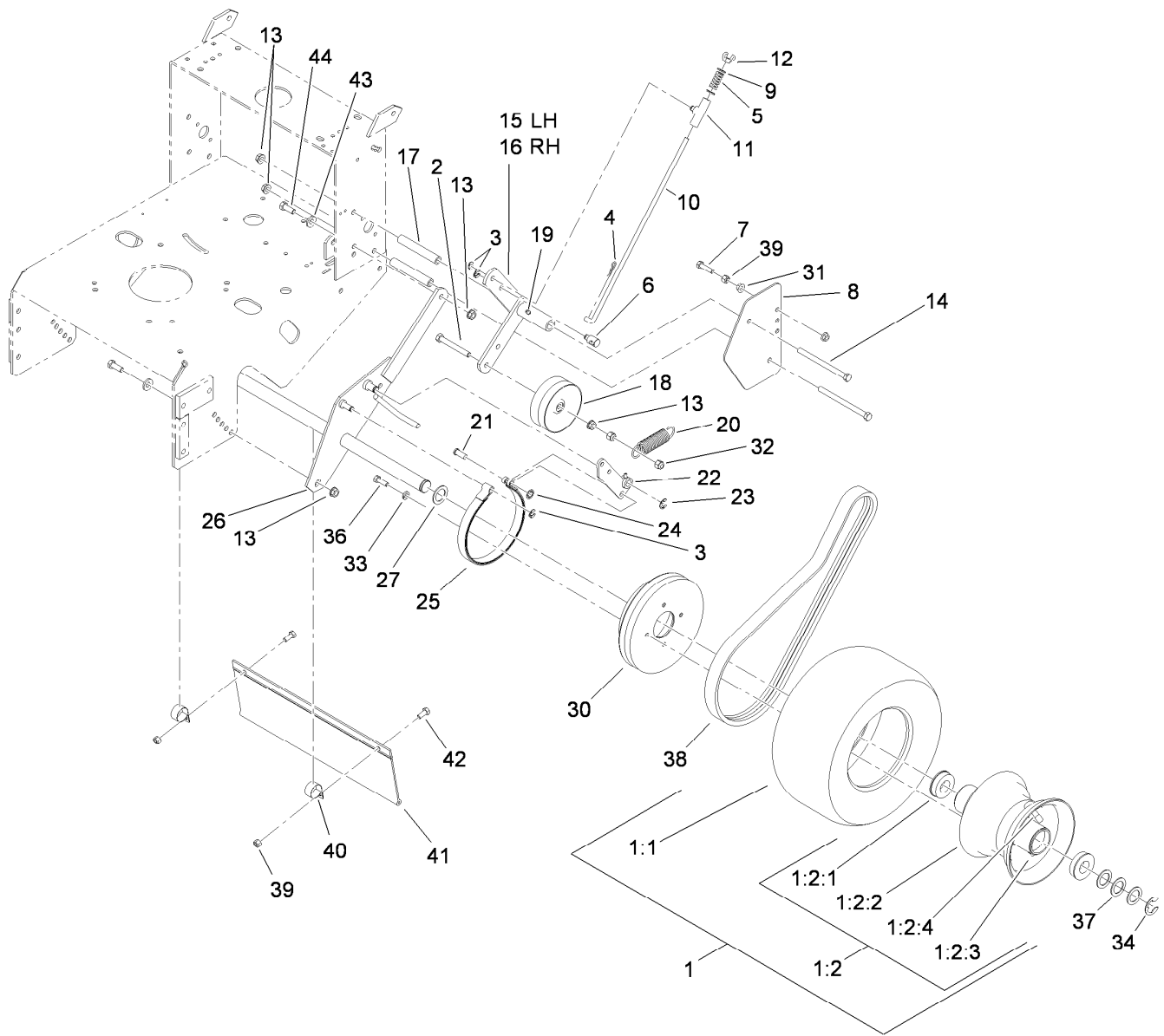

Drive Wheel and Brake Assembly

Ref.	Part Number	Qty.	Description	Ref.	Part Number	Qty.	Description
1	1-323719	2	Wheel And Tire ASM	14	323-39	4	Screw-HH
1:1	1-323720	1	Tire-Turfmaster	15	103-1615-03	1	Arm-Idler, LH
1:2	1-323328	1	Wheel And Hub ASM	16	103-1616-03	1	Arm-Idler, RH
1:2:1	1-323329	2	Bearing-Flanged	17	1-323283	4	Spacer-Shield
1:2:2		1	Rim ASM ●	18	119-7887	2	Pulley-Idler
1:2:3		1	Fitting-Grease ●	19	302-19	2	Fitting-Grease
1:2:4		1	Stem-Valve ●	20	1-603402	2	Spring-Extension
2	99-8664	2	Screw-HH	21	1-323307	2	Pin-Clevis
3	32151-47	6	Ring-Retaining	22	103-1611-03	2	Arm-Brake
4	1-806003	2	Pin-Cotter, Hair	23	32120-47	2	Ring-Retaining, External
5	1-323245	2	Spring-Compression	24	1-803051	2	Nut-Push
6	103-1864	2	Swivel-Lever, Drive	25	1-323262	2	Band-Brake
7	116-3515	2	Screw-HH Special	26	1-322117-03	1	Axle
8	1-323287-01	2	Shield-Wheel, Drive	27	1-543436	2	Washer-Spacer
9	3256-23	4	Washer-Flat	30	109-4359	2	Drum And Sheave ASM
10	1-323548	2	Linkage-Brake	31	32128-20	4	Nut-HF
11	110-5866	2	Swivel-Brake	32	3296-39	4	Nut-Lock, NI
12	1-513959	2	Wingnut-Nylock	33	1-805005	8	Washer-Lock
13	3290-357	10	Nut-HHF, Whiz	34	1-808519	2	Ring-Snap

● Not serviced separately

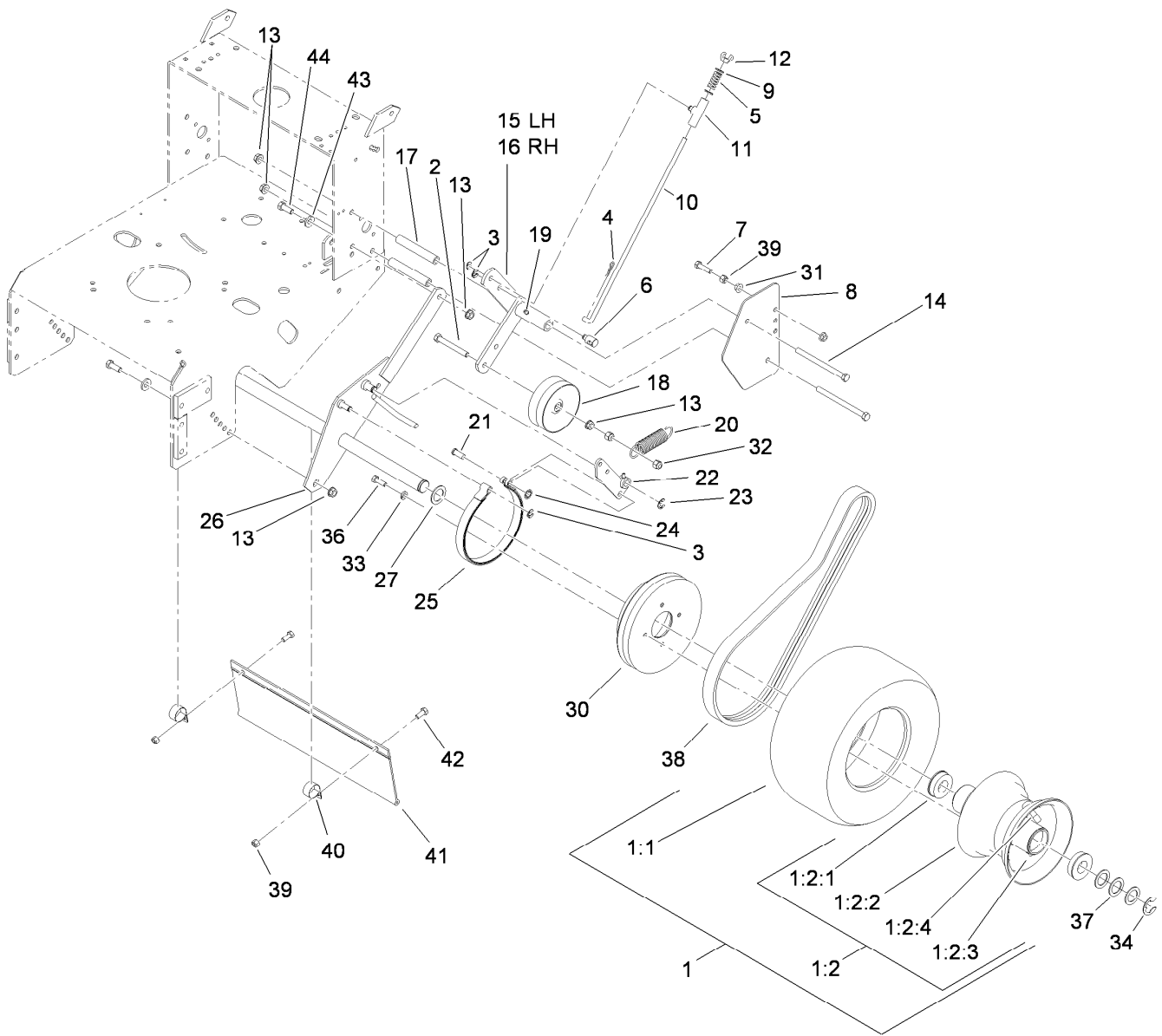

Drive Wheel and Brake Assembly (continued)

<i>Ref.</i>	<i>Part Number</i>	<i>Qty.</i>	<i>Description</i>	<i>Ref.</i>	<i>Part Number</i>	<i>Qty.</i>	<i>Description</i>
36	322-5	8	Screw-HH	41	98-3259	1	Shield-Trailing
37	1-523157	6	Washer-Spacer	42	322-3	2	Screw-HH
38	1-323631	2	V-Belt	43	98-5975	4	Washer-Belleville
39	3296-29	4	Nut-Lock, NI	44	323-6	4	Screw-HH
40	2412-104	2	Clamp-R				

● Not serviced separately

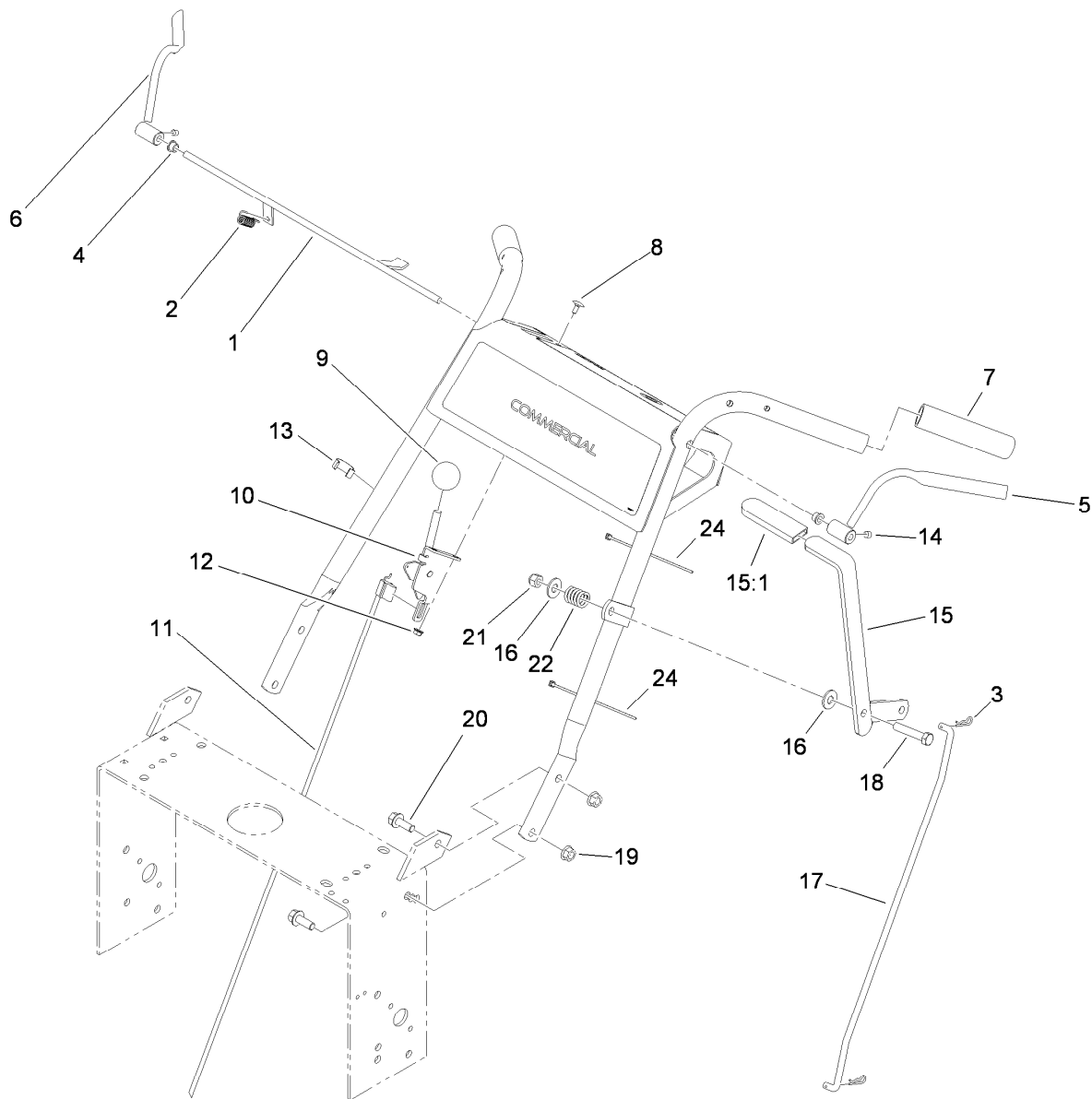

Handle Control Assembly

<i>Ref.</i>	<i>Part Number</i>	<i>Qty.</i>	<i>Description</i>	<i>Ref.</i>	<i>Part Number</i>	<i>Qty.</i>	<i>Description</i>
1	106-2717-03	1	Rod-Control, Operator Presence	12	32128-17	2	Nut-Lock, Flange
2	1-303363	1	Spring-Extension	13	1-303088	1	Clip-Cable
3	1-806003	2	Pin-Cotter, Hair	14	1-803322	2	Screw-Set
4	1-303365	2	Bushing-Nylon	15	1-322157	1	Lever ASM
5	106-5485	1	LH Operator Presence Control Lever ASM	15:1	1-303020	1	Grip-Lever
6	106-5486	1	RH Operator Presence Control Lever ASM	16	3256-4	2	Washer-Flat
7	104-9838	2	Grip-Foam	17	1-323298	1	Linkage-Blade, Upper
8	1-807513	2	Bolt-CARR	18	323-10	1	Screw-HH
9	1-603175	1	Knob-Ball	19	32128-21	4	Nut-HF
10	110-5547	1	Control Lever ASM	20	3234-11	4	Screw-HHF
11	119-1823	1	Cable-Control, Throttle	21	3296-39	1	Nut-Lock, NI
				22	1-303160	1	Spring-Compression
				24	1-303287	2	Tie-Cable

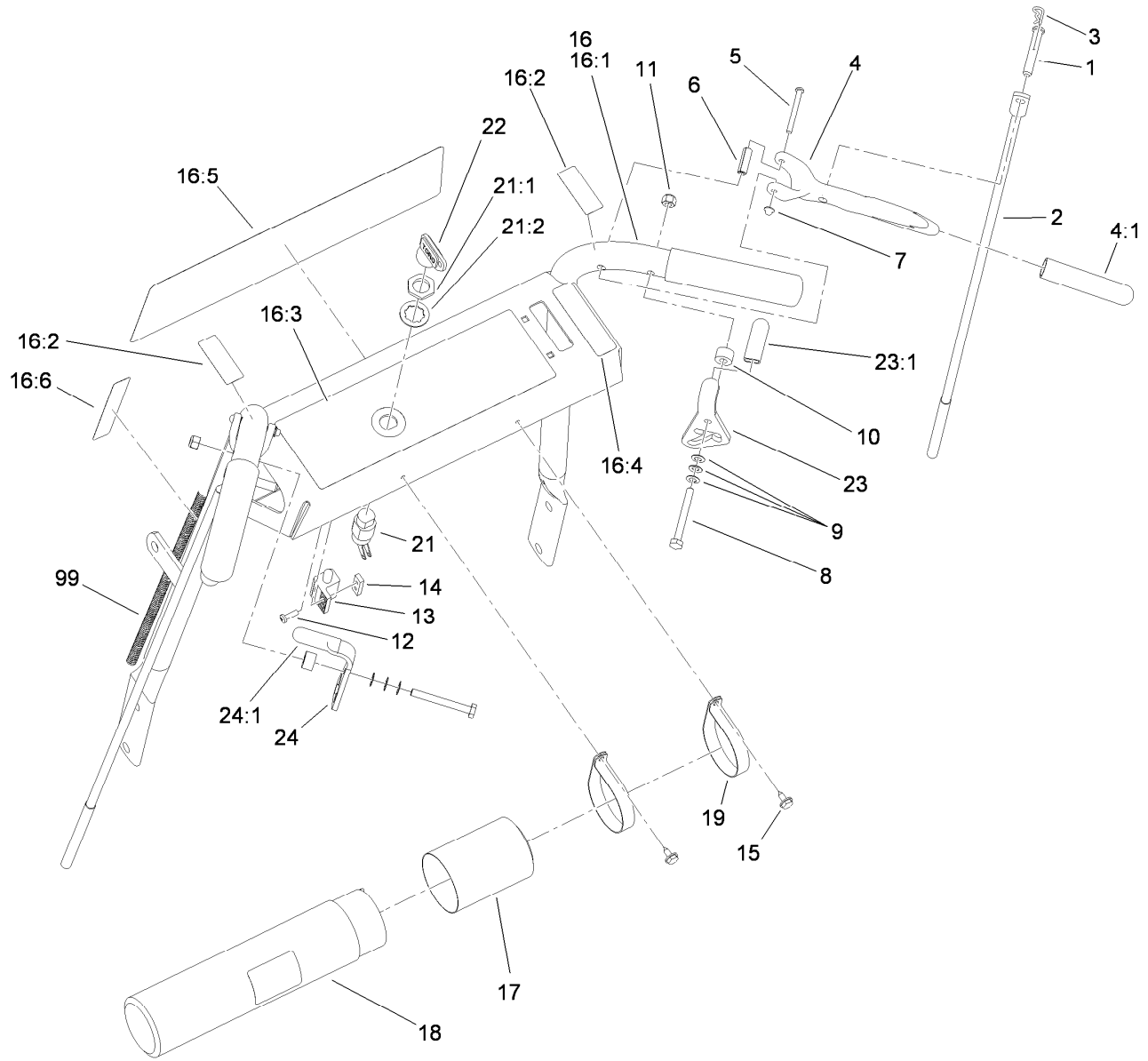

Handle Assembly

Ref.	Part Number	Qty.	Description	Ref.	Part Number	Qty.	Description
1	1-808286	2	Pin-Clevis	16:2	105-4111	2	Decal-Lock, Neutral
2	1-323359	2	Linkage-Wheel, Drive	16:3	106-2737	1	Decal-Warning
3	1-806003	2	Pin-Cotter, Hair	16:4	106-2733	1	Decal-Throttle
4	1-302006	2	Drive Lever ASM	16:5	110-6917	1	Decal
4:1	1-303021	1	Grip-Lever, Drive	16:6	95-5537	1	Decal-Engage, Deck
5	1-808250	2	Pin-Lever, Drive	17	104-7048	1	Cap-Housing
6	1-806340	2	Pin-Roll	18	104-7050	1	Tube-Manual
7	1-803001	2	Nut	19	2412-120	2	R-Clamp
8	321-18	2	Screw-HH	21	29-5560	1	Switch-On / Off
9	1-303435	6	Washer-Spring	21:1	218-461	1	Nut-HH
10	1-323549	2	Spacer	21:2	3254-5	1	Washer-Tooth, Internal
11	3296-42	2	Nut-Lock, NI	22	63-8360	1	Key-Ignition
12	3290-500	2	Screw-PPH	23	1-324280	1	RH Thumb Latch ASM
13	1-513051	1	Switch-Open, Normally	23:1	1-303019	1	Grip-Latch
14	1-633181	1	Plate-Tapped	24	1-324279	1	LH Thumb Latch ASM
15	32104-76	2	Screw	24:1	1-303019	1	Grip-Latch
16	119-3638	1	Handle ASM	99	116-2661	1	Harness-Wire
16:1		1	Pistol Grip Handle ASM ●				

● Not serviced separately

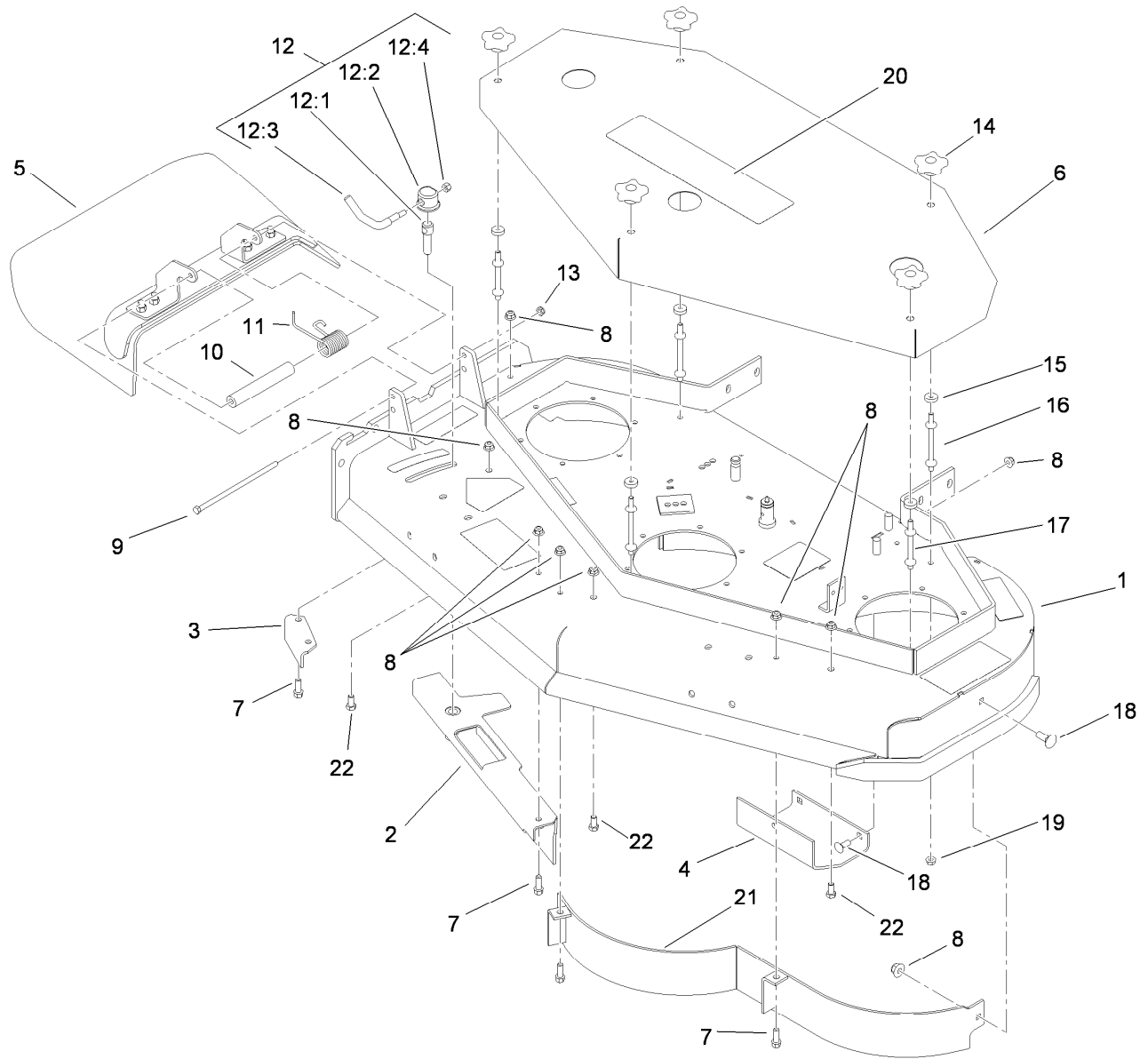

Deck Assembly

Ref.	Part Number	Qty.	Description	Ref.	Part Number	Qty.	Description
1	110-4909	1	Deck ASM	12:2	107-1644	1	Cap-Lock
2	110-0533-03	1	Baffle-Adjustable	12:3	106-3241	1	Lever-Lock
3	110-0744-01	1	Baffle-Discharge	12:4	3296-29	1	Nut-Lock, NI
4	107-3166-01	1	Skid	13	3296-47	1	Nut-Lock, NI
5	110-0758	1	Deflector ASM	14	106-4161	5	Knob-Handle
6	110-2119-01	1	Cover	15	1-323417	5	Washer
7	92-1624	5	Screw-HWH	16	1-303536	3	Stud-Shield, Belt (Long)
8	104-8301	12	Nut-Flange, NI	17	1-303537	2	Stud-Shield, Belt (Short)
9	322-50	1	Screw-HH	18	3231-2	4	Screw-CARR
10	105-4622	1	Spacer	19	32128-20	5	Nut-HF
11	104-8554	1	Spring-Torsion	20	112-9712	1	Decal
12	107-1664	1	Lever ASM	21	110-0735-03	1	Baffle ASM
12:1	106-3239	1	Screw-Lock	22	323-4	3	Screw-HH

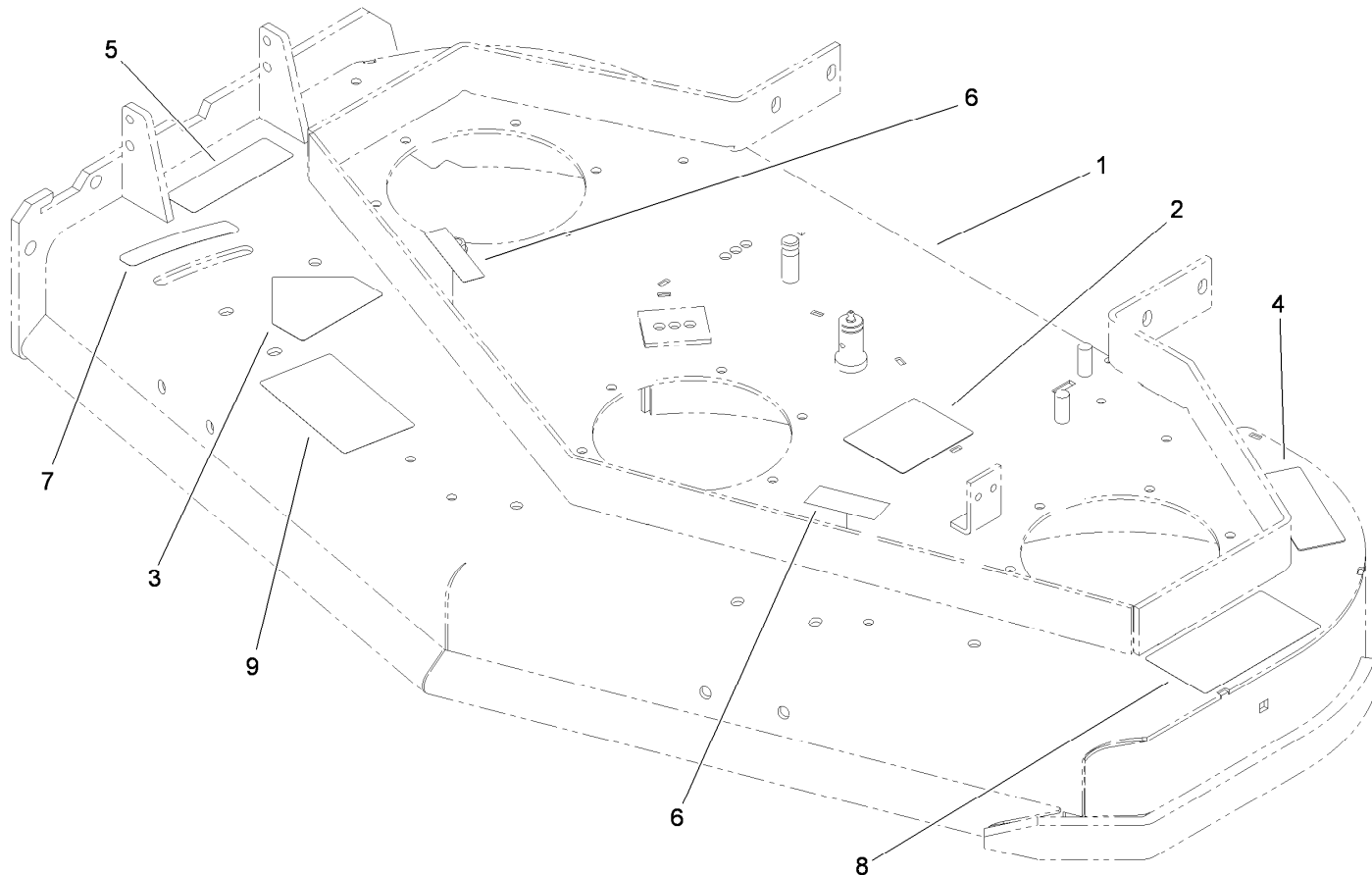

Deck Decal Assembly No. 110-4909

<i>Ref.</i>	<i>Part Number</i>	<i>Qty.</i>	<i>Description</i>
1		1	48 Inch Deck ASM ●
2	99-3943	1	Decal-Routing, Belt
3	43-8480	1	Decal-Danger
4	98-5130	1	Decal-Torque, Bolt
5	104-8569	1	Decal-Warning
6	98-5954	2	Decal-Cover, Missing
7	110-2067	1	Decal-Setting, Baffle
8	66-1340	1	Decal-Danger, Thrown Object
9	110-2068	1	Decal-Adjustment, Baffle

● Not serviced separately

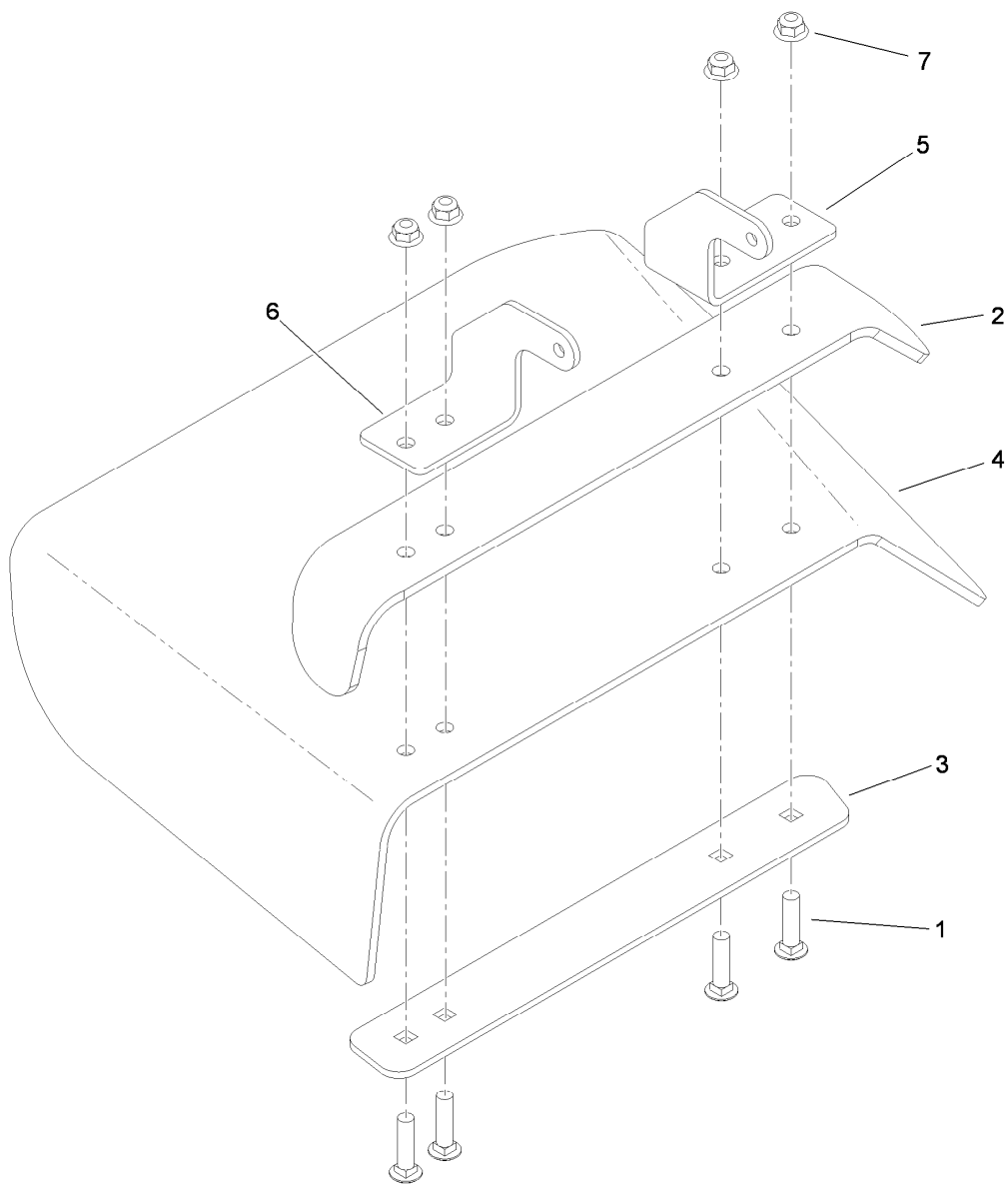

Deflector Assembly No. 110-0758

<i>Ref.</i>	<i>Part Number</i>	<i>Qty.</i>	<i>Description</i>
1	3231-4	4	Screw-CARR
2	106-3246-01	1	Deflector
3	106-3248-03	1	Strap-Discharge
4	110-0759	1	Deflector-Rubber
5	107-4197-01	1	Bracket-Hinge, Rear
6	107-4196-01	1	Bracket-Hinge, Front
7	104-8301	4	Nut-Flange, NI

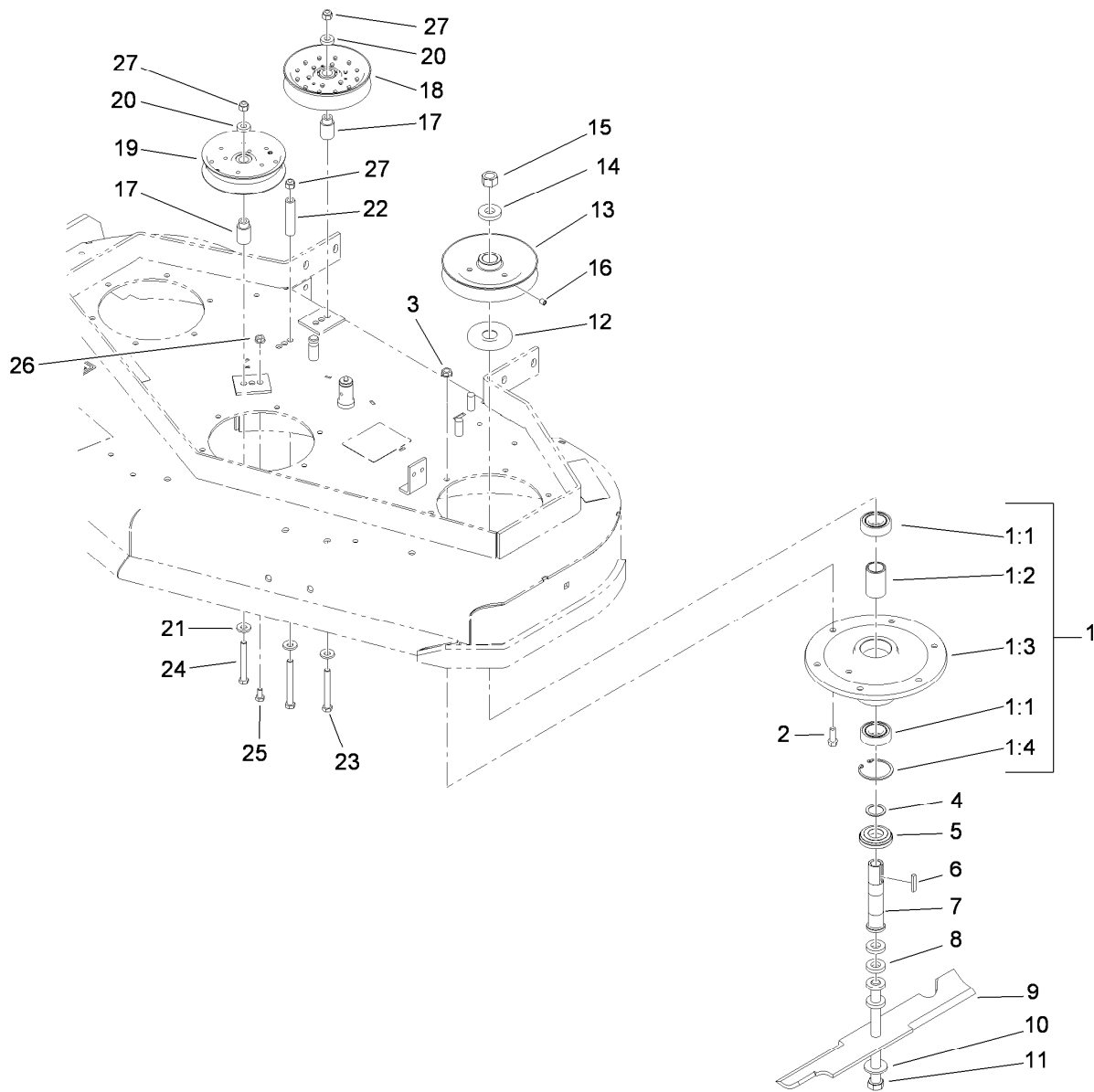

Sheave, Spindle and Blade Assembly

Ref.	Part Number	Qty.	Description	Ref.	Part Number	Qty.	Description
1	108-6697	3	Spindle Housing ASM	13	1-403183	3	Sheave
1:1	110-2118	2	Bearing	14	1-323339	3	Washer-Retainer, Sheave
1:2	110-2116	1	Spacer-Bearing	15	3219-6	3	Nut-Hex
1:3	108-6694	1	Housing-Spindle	16	1-803310	3	Screw-Set
1:4	32120-8	1	Ring-Snap	17	1-413113	2	Bushing-Idler
2	92-1624	18	Screw-HWH	18	1-403186	1	Idler-Pulley, Flat
3	104-8301	18	Nut-Flange, NI	19	1-613098	1	Pulley-Idler
4	110-4888	3	Washer-Spacer	20	5-0652	2	Spacer
5	103-2535	3	Spacer-Guard, Bottom	21	98-5975	3	Washer-Belleville
6	1-807267	3	Key	22	1-403188	1	Spacer
7	1-323529	3	Tube-Spindle, Short	23	323-15	1	Screw-HH
8	1-323539	12	Spacer	24	323-14	2	Screw-HH
9	107-3192-03	3	Blade-16.5 Inch (High Flow)	25	322-2	1	Screw-HH
10	1-513208	3	Washer-Spring	26	32128-20	1	Nut-HF
11	1-800861	3	Screw-Cap, HH	27	3296-39	3	Nut-Lock, NI
12	103-1330	3	Guard-Bearing, Top				

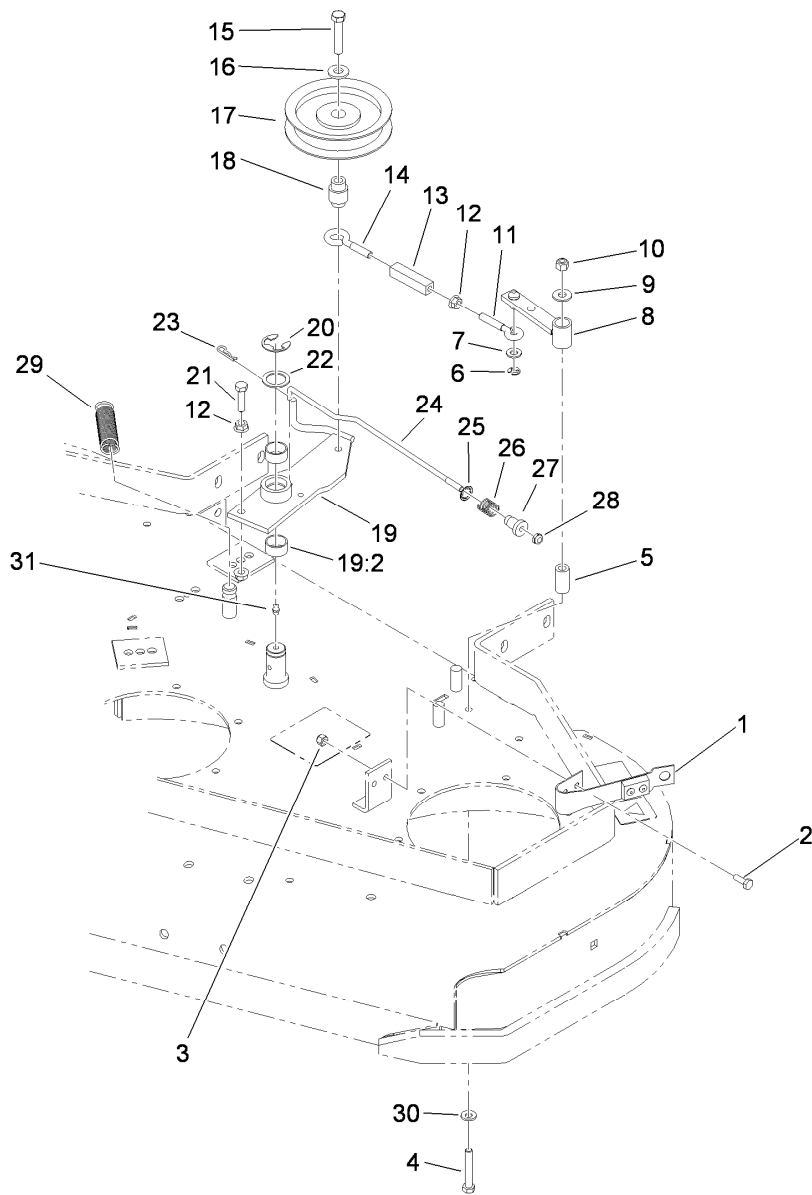

Idler Assembly

<i>Ref.</i>	<i>Part Number</i>	<i>Qty.</i>	<i>Description</i>	<i>Ref.</i>	<i>Part Number</i>	<i>Qty.</i>	<i>Description</i>
1	1-324372	1	Pad And Spring ASM	17	1-603843	1	Pulley-Idler
2	321-4	2	Screw-HH	18	1-303434	1	Bushing-Engagement
3	3296-42	2	Nut-Lock, NI	19	103-3600	1	Idler Arm ASM
4	322-10	1	Screw-HH	19:2	1-323729	2	Sleeve-Bearing
5	1-403179	1	Tube-Pivot	20	32151-103	1	Ring-Retaining, EXT
6	32120-35	1	Ring-Retaining, EXT	21	322-6	1	Screw-HH
7	3256-23	1	Washer-Flat	22	1-303352	1	Washer-Spindle
8	1-322235	1	Arm-Assist	23	1-806003	1	Pin-Cotter, Hair
9	3256-3	1	Washer-Flat	24	110-4932	1	Rod-Brake
10	3296-29	1	Nut-Lock, NI	25	1-323748	1	Ring-Push On
11	1-303238	1	Eyebolt-Thread, RH	26	1-323747	1	Spring-Compression
12	32128-20	3	Nut-HF	27	1-323746	1	Spacer-Flanged
13	1-303236	1	Body-Turnbuckle	28	3296-56	1	Nut-Lock, NI
14	1-303348	1	Eyebolt-Thread, LH	29	1-323071	1	Spring-Extension
15	702809	1	Screw-HH	30	1-303334	1	Washer-Spring
16	98-5975	1	Washer-Belleville	31	302-19	1	Fitting-Grease

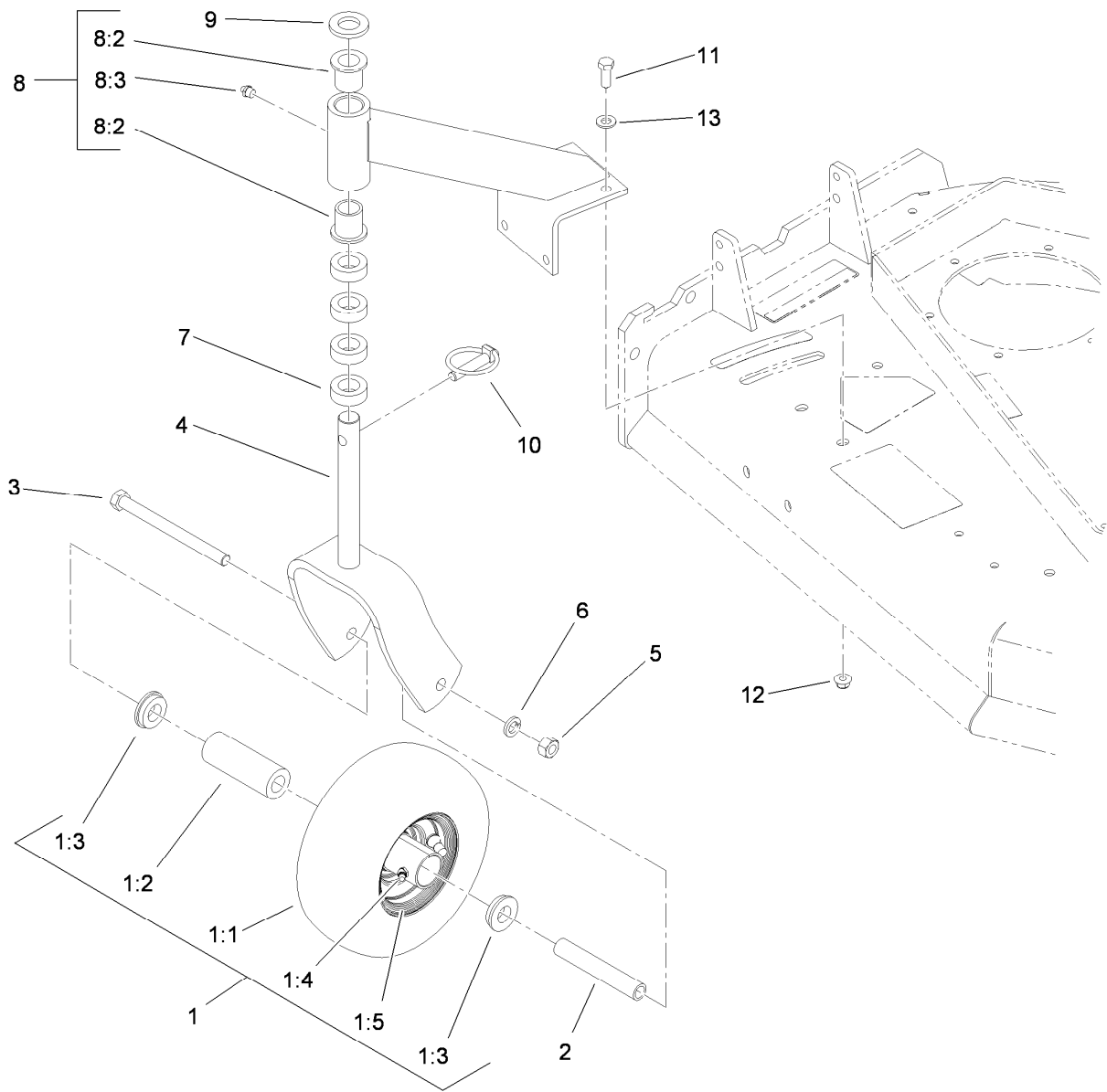

Caster Assembly

Ref.	Part Number	Qty.	Description
1	110-5023	2	Wheel And Tire ASM
1:1		1	Tire ●
1:2	1-513809	1	Bearing
1:3	1-513810	2	Bushing
1:4	302-61	1	Fitting-Grease
1:5		1	Wheel ●
2	1-513547	2	Spacer
3	325-20	2	Screw-HH
4	1-322145-01	2	Fork
5	3217-9	2	Nut-HH

Ref.	Part Number	Qty.	Description
6	3253-7	2	Washer-Lock
7	1-303314	8	Spacer-Caster
8	110-2130	2	Support ASM
8:2	1-303514	2	Bearing-Flanged
8:3	302-52	1	Fitting-Grease
9	1-513338	2	Washer-Flat
10	1-809020	2	Pin
11	323-6	8	Screw-HH
12	104-8301	8	Nut-Flange, NI
13	3256-24	8	Washer-Flat

● Not serviced separately

Attachments and Accessories

For 30638 Commercial Walk-Behind Mower Fixed Deck, Pistol Grip, Gear Drive with 48in TURBO FORCE Cutting Unit

Product Name	Model/Part
Blade-Low Flow, 16.5 inch	107-3193-03
Blade-Mid Flow, 16.5 inch.....	107-3194-03
Blade-Atomic, 16.5 inch.....	107-3195-03
Blade-Recycling, 16.5 inch	107-3196-03
Bagging Enhancement Kit	108-4091
Blade-Hi Flow, 16.5 inch (6 Pack)	110-0414
Blade-Lo Flow, 16.5 inch (6 Pack)	110-0415
Blade-Recycler, 16.5 inch (6 Pack).....	110-0416
Blade-Atomic, 16.5 inch (6 Pack).....	110-0417
Blade-Mid Flow, 16.5 inch (6 Pack).....	110-0418
48 inch Recycler Kit	110-2060
Weight Kit	110-2085
Operator Controlled Discharge Chute Kit.....	115-4195
Soft Bag (3 Bushel).....	30104
Sulky.....	30109

Notes:



Count on it.