



# TITAN Zero-Turn-Radius Riding Mowers

## Setup Instructions

### Loose Parts

Use the chart below to verify that all parts have been shipped.

Procedure	Description	Qty.	Use
<b>1</b>	No parts required	–	Connect the battery.
<b>2</b>	No parts required	–	Set up the motion control levers.
<b>3</b>	Rollbar Rollbar support Pivot bracket Flat spacer Pivot pin with hairpin and lanyard Reinforcing bracket Large washer Bolt (1/2 x 4–1/2 inches) Bolt (1/2 x 3–1/2 inches) Cylindrical spacer Flat washer Flange locknut (1/2 inch) Hex locknut (1/2 inch) Flange locknut (5/16 inch, may be pre-installed) Conical rubber bumper (may be pre-installed) Small rubber bumper (may be pre-installed)	1 2 4 4 2 2 4 2 8 2 4 8 2 2 2 2	Install the Roll Over Protection System (ROPS).
<b>4</b>	Hose coupling (not included with CE models) Cut off baffle (CE models only) Bolt (5/16 x 5/8 inch, 54 inch CE units only) Ignition Key Operator's Manual Engine Operator's Manual Operator Training Material	1 1 2 1 1 1 1	Complete the setup.

**Note:** Determine the left and right sides of the machine from the normal operating position.

# 1

## Connecting the Battery

### No Parts Required

### Procedure

1. Locate the battery and negative battery cable in the center of the machine.
2. Remove the black plastic cap from the negative battery post. Remove the fasteners from the negative battery cable and use them to secure the negative battery cable to the negative battery post (Figure 1).

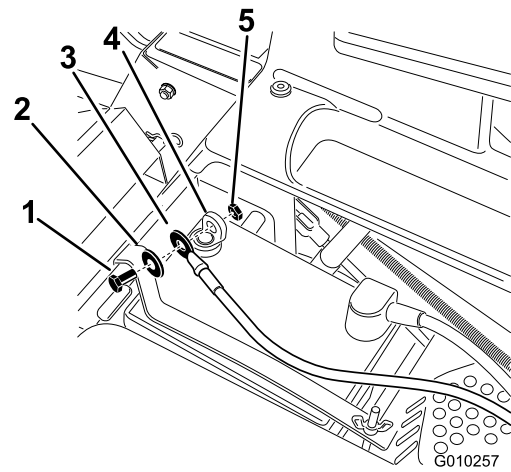

Figure 1

- |                           |                          |
|---------------------------|--------------------------|
| 1. Bolt                   | 4. Negative battery post |
| 2. Washer                 | 5. Nut                   |
| 3. Negative battery cable |                          |

# 2

## Setting Up the Motion Control Levers and the Seat

### No Parts Required

### Procedure

1. Locate the motion control levers attached but folded down on the machine.
2. Remove the upper bolt (3/8 x 1 inch) and washer; loosen the lower bolt (3/8 x 1 inch). Raise the motion control levers to the upright position.
3. Align the holes in the motion control lever with the holes in the control arm shaft and install the bolt and washer removed previously. Hand tighten all fasteners. Repeat this for both controls levers.
4. Setup the seat as follows (Figure 2):

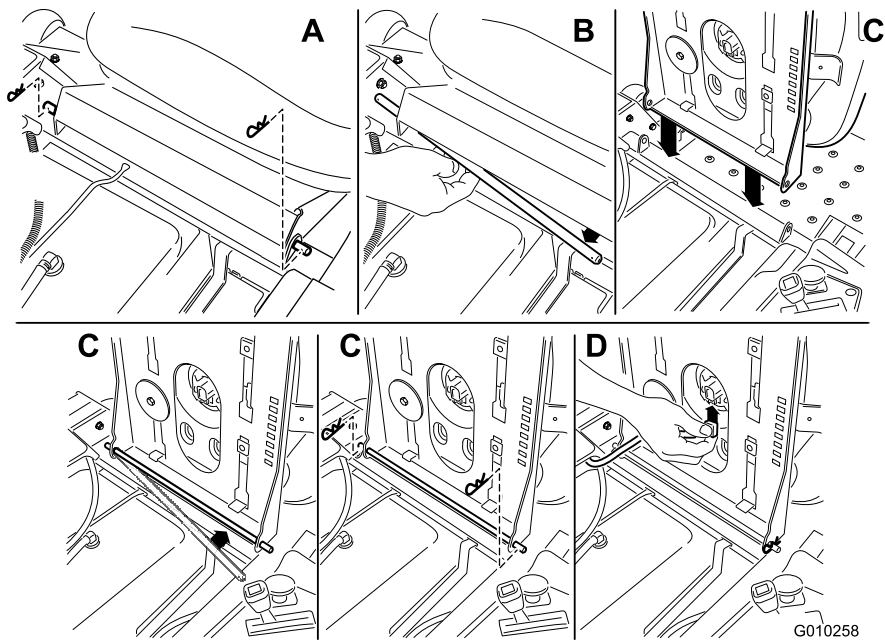

**Figure 2**

G010258

- A. With the motion control levers in the outward, neutral lock position, remove the hairpin cotters on the seat rod securing the seat to the machine.
  - B. Slide the seat rod out from the brackets and seat frame.
  - C. Rotate the seat 180 degrees and install it into the bracket you removed it from, using the rod and hairpin cotters removed previously.
  - D. Connect the interlock switch cable to the seat.
  - E. Lower the seat into the operating position.
5. Move the control levers back to the center position (neutral).
  6. Verify the motion control levers are properly aligned. Adjust as necessary. Tighten all fasteners.

# 3

## Installing the Roll Over Protection System (ROPS)

### Parts needed for this procedure:

1	Rollbar
2	Rollbar support
4	Pivot bracket
4	Flat spacer
2	Pivot pin with hairpin and lanyard
2	Reinforcing bracket
4	Large washer
2	Bolt (1/2 x 4-1/2 inches)
8	Bolt (1/2 x 3-1/2 inches)
2	Cylindrical spacer
4	Flat washer
8	Flange locknut (1/2 inch)
2	Hex locknut (1/2 inch)
2	Flange locknut (5/16 inch, may be pre-installed)
2	Conical rubber bumper (may be pre-installed)
2	Small rubber bumper (may be pre-installed)

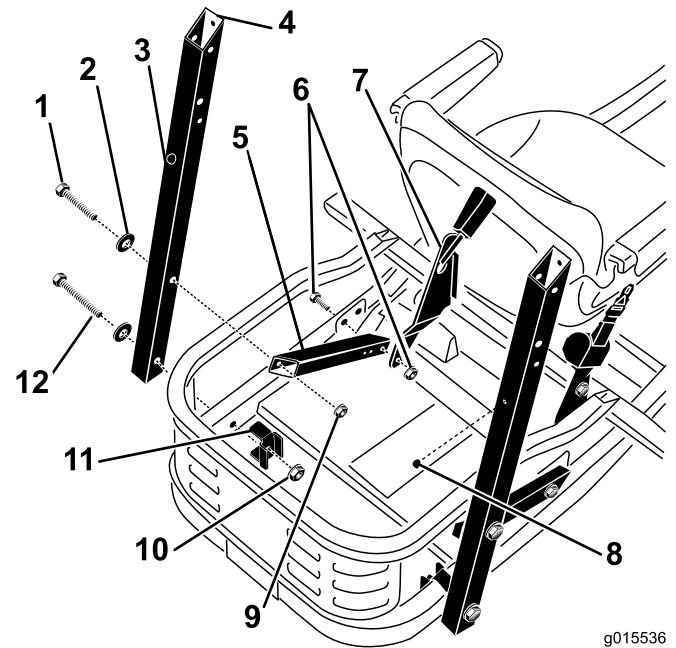

Figure 4

- |   |                                   |
|---|-----------------------------------|
| 1. Bolt (1/2 x 3-1/2 inches) (2)                            | 7. Seat belt assembly, existing   |
| 2. Large washer (4)   | 8. Small rubber bumper (2)        |
| 3. Rollbar support  | 9. Hex locknut (1/2 inch) (2)     |
| 4. Cutout faces the rear                                    | 10. Flange locknut (1/2 inch) (2) |
| 5. Brace, existing  | 11. Reinforcing bracket (2)       |
| 6. Bolt (1/2 x 1-1/4 inch) and locknut (1/2 inch), existing | 12. Bolt (1/2 x 4-1/2 inch) (2)   |

### Installing the Rollbar Supports

Complete the following steps for both left and right rollbar supports.

1. Locate the factory installed brace attached to the frame between the engine and the rear wheel (see Figure 3 and Figure 4).

**Note:** If preferred, the rear wheels may be removed for easier access to the brace.

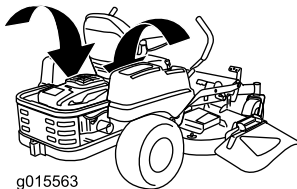

Figure 3

Location of the braces

2. Loosen the locknut that secures the brace to the frame. Stop when the brace swings freely (Figure 4).
3. Attach the rollbar support to the frame and the brace to the rollbar support as shown in Figure 4. Leave the bolts loose enough that the parts are free to shift around.

**Note:** Ensure that the cutout at the top of the support tube faces the rear of the machine.

**Note:** Note the orientation of the reinforcing bracket.

### Attaching the Pivot Brackets

Assemble the pivot brackets to the rollbar as shown in Figure 5. Leave the bolts loose enough that the parts are free to shift around.

**Note:** Ensure that the locknuts are on the inside of the support tube.

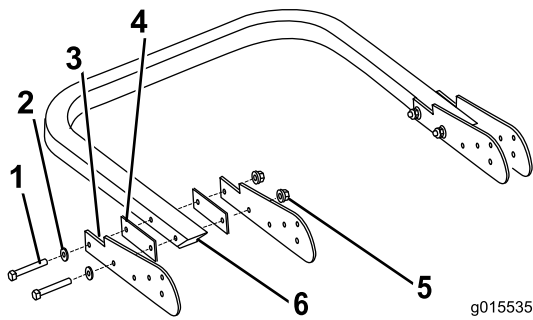

**Figure 5**

- |                                       |                                |
|---------------------------------------|--------------------------------|
| 1. Bolt (1/2 x 3-1/2 inches) (4)      | 4. Flat spacer (4)             |
| 2. Flat washer (4)                    | 5. Flange locknut (4)          |
| 3. Pivot bracket, notch facing up (4) | 6. Rollbar, cutout facing down |

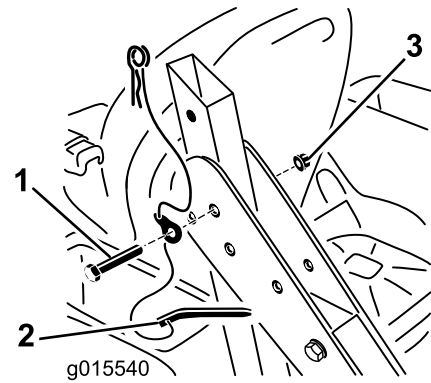
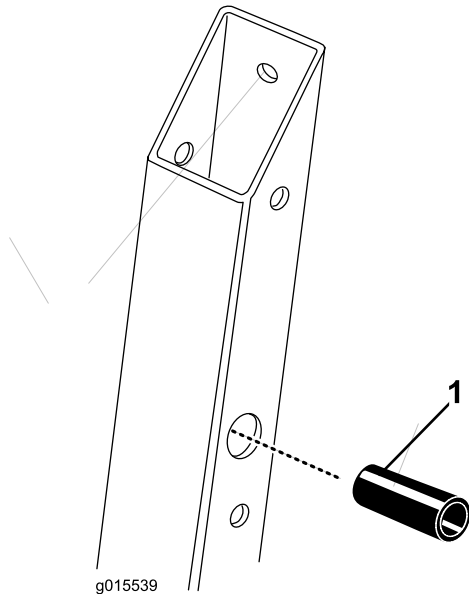

**Figure 7**

- |   |                       |
|---|-----------------------|
| 1. Bolt (1/2 x 3-1/2 inch) (2)            | 3. Flange locknut (2) |
| 2. Pivot pin with hairpin and lanyard (2) |                       |

## Attaching the Rollbar

1. Insert the cylindrical spacer in the pivot holes in both rollbar supports (Figure 6).



**Figure 6**

- |                     |                       |
|---------------------|-----------------------|
| 1. Large pivot hole | 2. Cylindrical spacer |
|---------------------|-----------------------|

2. Lift the rollbar with the cutouts in ends of the tube facing up and align the pivot holes with the cylindrical spacers in the rollbar supports.

**Note:** A second person to perform the next step will be helpful.

3. Attach the rollbar to the rollbar supports as shown in Figure 7. Leave the bolts just loose enough to allow the rollbar to freely pivot.

**Note:** Ensure that the tab to which the lanyard is attached is angled away from the surface of the pivot bracket.

4. Raise the rollbar into the upright position and lock it in place with both pivot pins as shown in Figure 8.

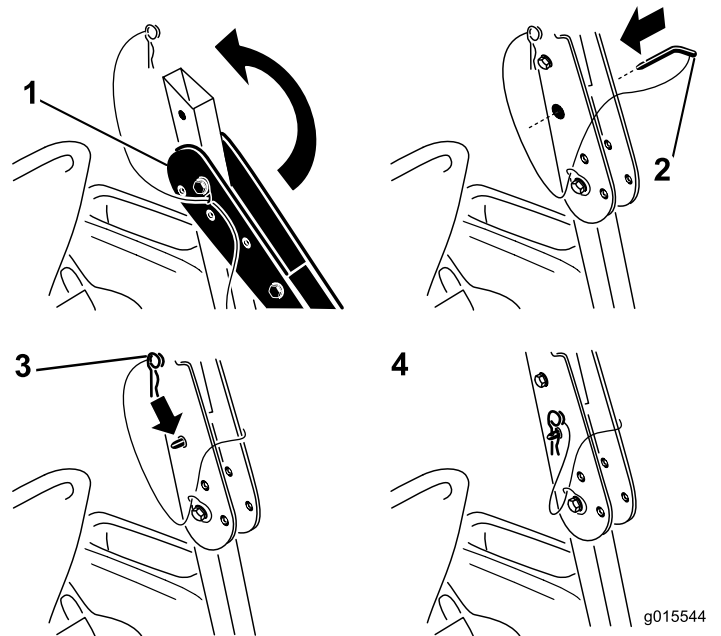

**Figure 8**

- |              |                                |
|--------------|--------------------------------|
| 1. Rollbar   | 3. Hairpin                     |
| 2. Pivot pin | 4. Rollbar, upright and locked |

## Making Final Adjustments

1. Tighten the fasteners in the order specified in the following table. Figure 4 and Figure 5 will help identify the parts.

Sequence	Description	Torque
1	Three bolts on each side attaching the pivot brackets to the rollbar and rollbar support. Ensure that the tab to which the lanyard is attached is pointed upward.	400 ± 40 in-lbs (45 ± 4 N-m)
2	Two bolts on each side attaching the rollbar support to the frame and the rollbar support to the brace .	300 ± 30 in-lbs (34 ± 3 N-m)
3	One bolt on each side attaching the braces to the machine frame.	75 ± 8 ft-lbs (102 ± 11 N-m)

**Note:** Do not exceed torque specifications. Doing so may cause structural damage to the ROPS or the frame of the machine.

- If necessary, install both small rubber bumpers. Press the small flange on the back of each into the holes on the back of the rollbar supports (Figure 4).
- Remove the pivot pins and ensure that the rollbar pivots freely up and down. If it does not, remove the rollbar and verify that the cylindrical spacers are correctly installed as previously described in Attaching the Rollbar.
- If the conical rubber bumpers are not pre-installed, unlock the rollbar and put it in the down position. Install the conical rubber bumpers inside the cutout at the top of the rollbar supports as shown in Figure 9. Secure them using the 5/16 inch flange nuts.

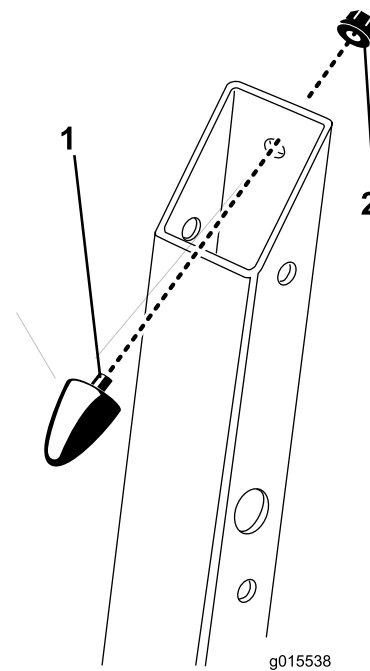

**Figure 9**

- Conical rubber bumper
- Flange nut (5/16 inch)

- Lock the rollbar in the upright position with the pivot pins. Use the hairpins at the end of each lanyard to secure the pivot pins (Figure 8).

**Important:** The hairpins at the end of both lanyards must be inserted into the holes on the straight end of each pivot pin until they lock in place.

## 4

## Completing the Setup

### Parts needed for this procedure:

1	Hose coupling (not included with CE models)
1	Cut off baffle (CE models only)
2	Bolt (5/16 x 5/8 inch, 54 inch CE units only)
1	Ignition Key
1	<i>Operator's Manual</i>
1	<i>Engine Operator's Manual</i>
1	Operator Training Material

## Procedure

### Checking the Tire Pressure

Check the front and rear tires for proper inflation. Refer to Checking the Tire Pressure in the *Operator's Manual* for the recommended inflation pressure.

### **Checking the Side Discharge Chute**

Remove the packing restraint holding the side discharge chute up and lower the chute into place.

### **Checking the Engine Oil Level**

Before you start the engine and use the machine, check the oil level in the engine crankcase; refer to Checking the Oil Level in the *Operator's Manual*.

### **Checking the Hydraulic Oil Level**

Before you start the engine and use the machine, check the hydraulic oil level in the reservoir behind the seat; refer to Checking the Oil Level in the *Operator's Manual*.

### **Checking the Mower Adjustment**

The mower deck was leveled at the factory. If the mower is not cutting level, adjust the side-to-side level and the front-to-rear blade slope. See the *Operator's Manual* for the proper procedure.

### **Review the Remaining Parts**

Keep all the following items with the machine:

- Ignition Key
- Hose Coupling (not included on CE models)
- Cut off baffle (CE models only)
- 5/16 inch bolts (54 inch CE units only)
- *Operator's Manual*
- *Engine Operator's Manual*
- View the Operator training material.



**Count on it.**