



**Count on it.**

**Parts Catalog**

**Greensmaster® 1000 Mower**

Model No. 04034—Serial No. 311000001 and Up

# Ordering Replacement Parts

To order replacement parts, please supply the part number, the quantity, and the description of each part desired.

## Understanding Reference Numbers

Each identified part in an illustration has a reference number. The reference number for a part also appears in the parts list, along with other information about the part.

This catalog uses two special reference number formats, one to indicate parts in a service assembly and another to indicate the quantity of a given part in an illustration.

## Service Assembly Reference Numbers

Parts in service assemblies have reference numbers in the form a:b. The a represents the reference number of the entire service assembly and the b represents a sequential number unique to each part within the service assembly.

For example, a wheel assembly might be identified by reference number 6, the tire by 6:1, the valve by 6:2, and the wheel by 6:3. When you order the assembly identified by reference number 6, you receive all parts identified by reference numbers 6:1, 6:2, and 6:3. However, you may also order any part individually. Reference numbers of this type appear in illustration and in parts lists.

## Reference Numbers Indicating Quantity

In an illustration, if a reference number indicates more than one part, the reference number has the form nX y. The n represents the quantity of the part, the X is the multiplication symbol, and the y represents the reference number.

For example, in an illustration, the reference number 2X 37 means that two of the parts identified by reference number 37 are indicated.

# List of Abbreviations

**AR:** as required

**ASM:** assembly

**BBC:** blade brake control

**BHTF:** button head thread forming

**CARR:** carriage

**CCW:** counter clockwise

**CW:** clockwise

**DEG:** degrees

**ECM:** electronic control module

**EXT:** external

**FH:** flat head

**GA:** gauge

**HD:** heavy-duty

**HF:** hex flange

**HH:** hex head

**HHF:** hex head flange

**HHFTF:** hex head flange thread forming

**HJ:** hex jam

**HLH:** hex lag head

**HOC:** height-of-cut

**HSBH:** hex socket button head

**HSFH:** hex socket flat head

**HSH:** hex socket head

**HWH:** hex washer head

**HWHTF:** hex washer head thread forming

**HYD:** hydraulic

**LH:** left hand

**LP:** Liquid Propane

**NI:** nylon insert

**NPTF:** national pipe thread fine

**PFH:** phillips flat head

**PPH:** phillips pan head

**PPHTF:** phillips pan head thread forming

**PRH:** phillips round head

**PTH:** phillips truss head

**PTO:** power-take-off

**RH:** right hand

**ROPS:** roll-over protection system

**RRB:** rear roller brush

**SFH:** slotted fillister head

**SHH:** slotted hex head

**SHWH:** slotted hex washer head

**SPH:** slotted pan head

**SQH:** square head

**SRH:** slotted round head

**STD:** standard

**TAP:** self tapping

**TTH:** torx truss head

# Contents

Frame Assembly.....	4
Engine Mount And Frame Assembly.....	5
Reel Drive Assembly.....	6
Reel Assembly.....	8
Drum Drive Assembly.....	9
Drum and Basket Assembly.....	11
Differential Assembly No. 93-6055.....	12
Inner Countershaft Assembly.....	13
Outer Crankshaft Assembly.....	14
Engine Assembly.....	15
Bellcrank Assembly.....	16
Handle Assembly.....	17
Cylinder and Crankcase Assembly.....	19
Piston and Crankshaft Assembly.....	20
Valve and Camshaft Assembly.....	21
Lubrication Equipment Assembly.....	22
Cooling Equipment Assembly.....	23
Electric Equipment Assembly.....	24
Control Equipment Assembly.....	25
Carburetor Assembly.....	26
Air Filter and Muffler Assembly.....	27
Fuel Tank and Fuel Valve Assembly.....	28
Starter Assembly.....	29
Label Set.....	30
Attachments and Accessories.....	31

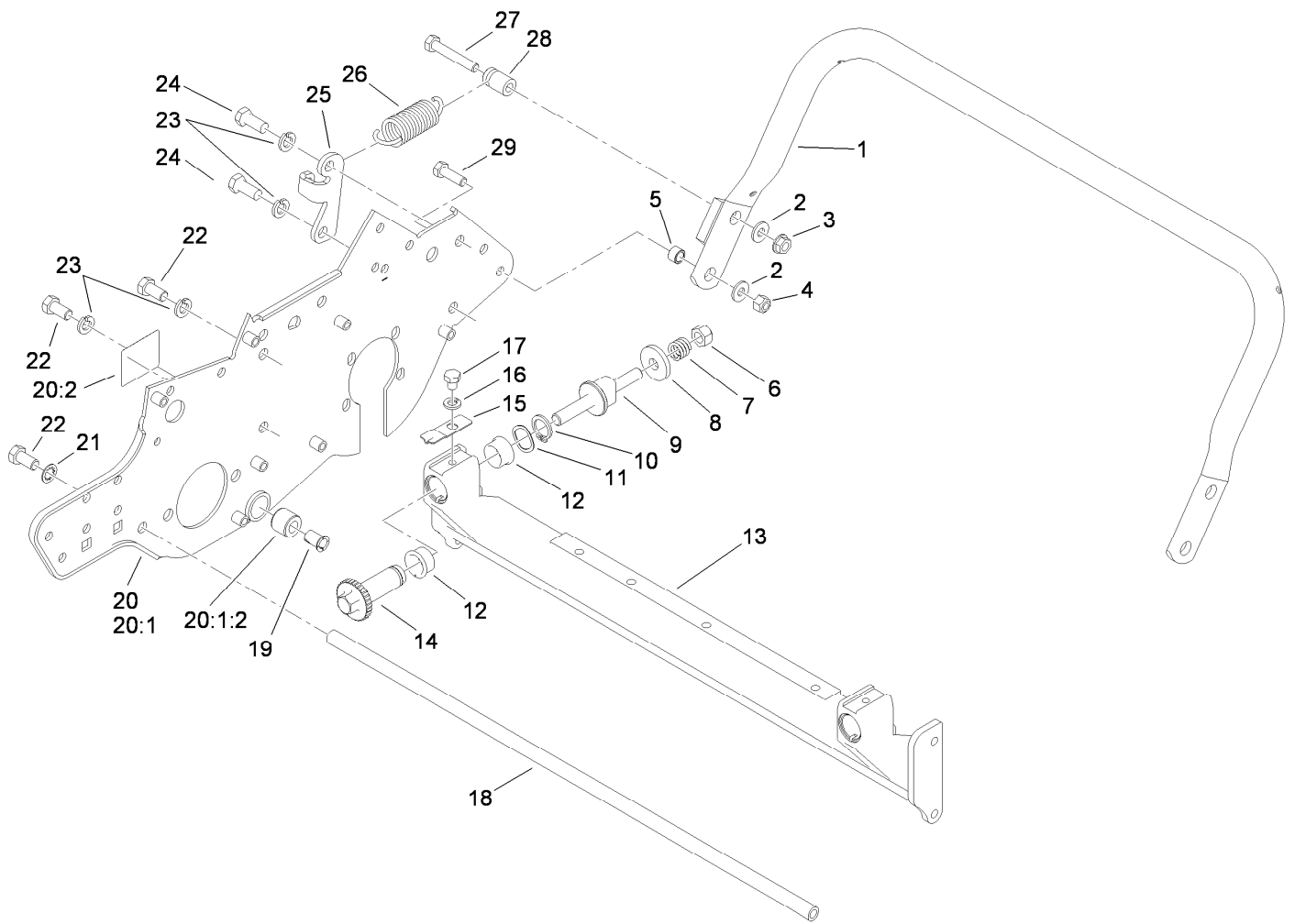

## Frame Assembly

Ref.	Part Number	Qty.	Description	Ref.	Part Number	Qty.	Description
1	65-7850-03	1	Kickstand ASM	18	88-7110	1	Rod-Support, Frame
2	3256-2	3	Washer-Flat	19	52-2890	2	Bushing-Nylon
3	32128-25	1	Nut-HF	20	93-6093	1	RH Side Plate ASM
4	3296-29	2	Nut-Lock, NI	20:1		1	RH Sideplate/Bushing ASM
5	65-7910	2	Spacer				●
6	33025-00	2	Nut-Lock, NI	20:1:2	63-9510	1	Bushing
7	99-3755	2	Spring-Compression	20:2	93-9389	2	Decal-Warning, Belt (Japan)
8	99-2098	2	Washer	20:2	93-9356	2	Decal-Warning, Belt
9	99-2096	2	Screw-Adjuster, Bedbar	21	3254-6	2	Washer-Lock, Internal
10	32120-93	2	Ring-Retaining	22	323-4	6	Screw-HH
11	106-5335	2	Washer-Wave	23	3253-21	4	Washer-Lock
12	106-5344	4	Bushing-Flange, Keyed	24	323-5	2	Screw-HH
13	112-9272-01	1	Crossmember	25	65-7890	1	Bracket
14	106-5363	2	Shaft-Adjuster	26	65-7880	1	Spring-Extension
15	99-2097	2	Detent	27	322-10	1	Screw-HH
16	3253-4	2	Washer-Lock	28	65-7900	1	Retainer-Spring
17	322-26	2	Screw-HH	29	322-5	2	Screw-HH

● Not serviced separately

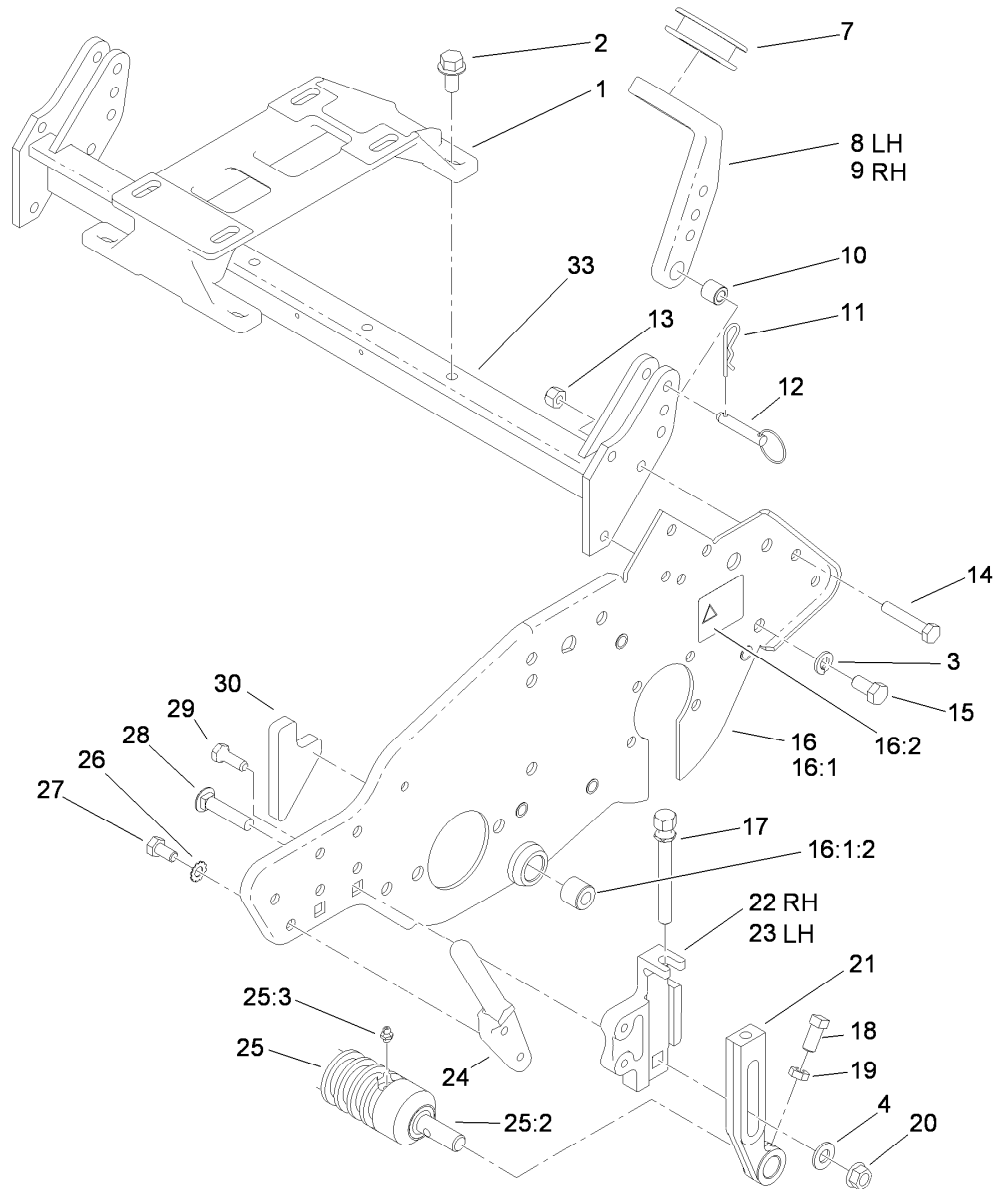

## Engine Mount And Frame Assembly

Ref.	Part Number	Qty.	Description	Ref.	Part Number	Qty.	Description
1	88-7670	1	Mount-Engine	17	93-6051	2	Screw-HOC
2	3234-1	4	Screw-HHF	18	3242-4	2	Screw-Set, SQH
3	3253-21	4	Washer-Lock	19	3218-2	2	Nut-Jam
4	3256-24	2	Washer-Flat	20	32128-21	2	Nut-HF
7	65-7510	2	Grommet-Handle	21	93-6090	2	Arm-HOC
8	93-6038	1	Arm-Support, Handle (LH)	22	93-6048	1	Bracket-HOC, RH
9	93-6037	1	Arm-Support, Handle (RH)	23	93-6049	1	Bracket-HOC, LH
10	93-6024	2	Bushing-Support, Handle	24	65-8570	2	Rod-Mounting
11	3290-467	2	Pin-Hair	25	99-6241	1	Wiehle Roller ASM (.20 Inch Spacing)
12	93-6029	2	Pin-Clevis, Ring	25:2	52-3180	2	Bearing-Roller, Front
13	3296-29	2	Nut-Lock, NI	25:3	302-5	2	Fitting-Grease
14	322-9	2	Screw-HH	26	3255-8	4	Washer-Lock
15	323-4	2	Screw-HH	27	322-2	4	Screw-HH
16	93-6094	1	LH Side Plate ASM	28	3231-5	2	Screw-CARR
16:1		1	LH Sideplate/Bushing ASM	29	92-8914	4	Bolt-Face, Tapered
16:1:2	63-9510	1	Bushing	30	93-6064	1	Seal-Catcher, Grass
16:2	93-9356	1	Decal-Warning, Belt	33	93-6025-01	1	Tube-Frame, Rear
16:2	93-9389	1	Decal-Warning, Belt (Japan)				

● Not serviced separately

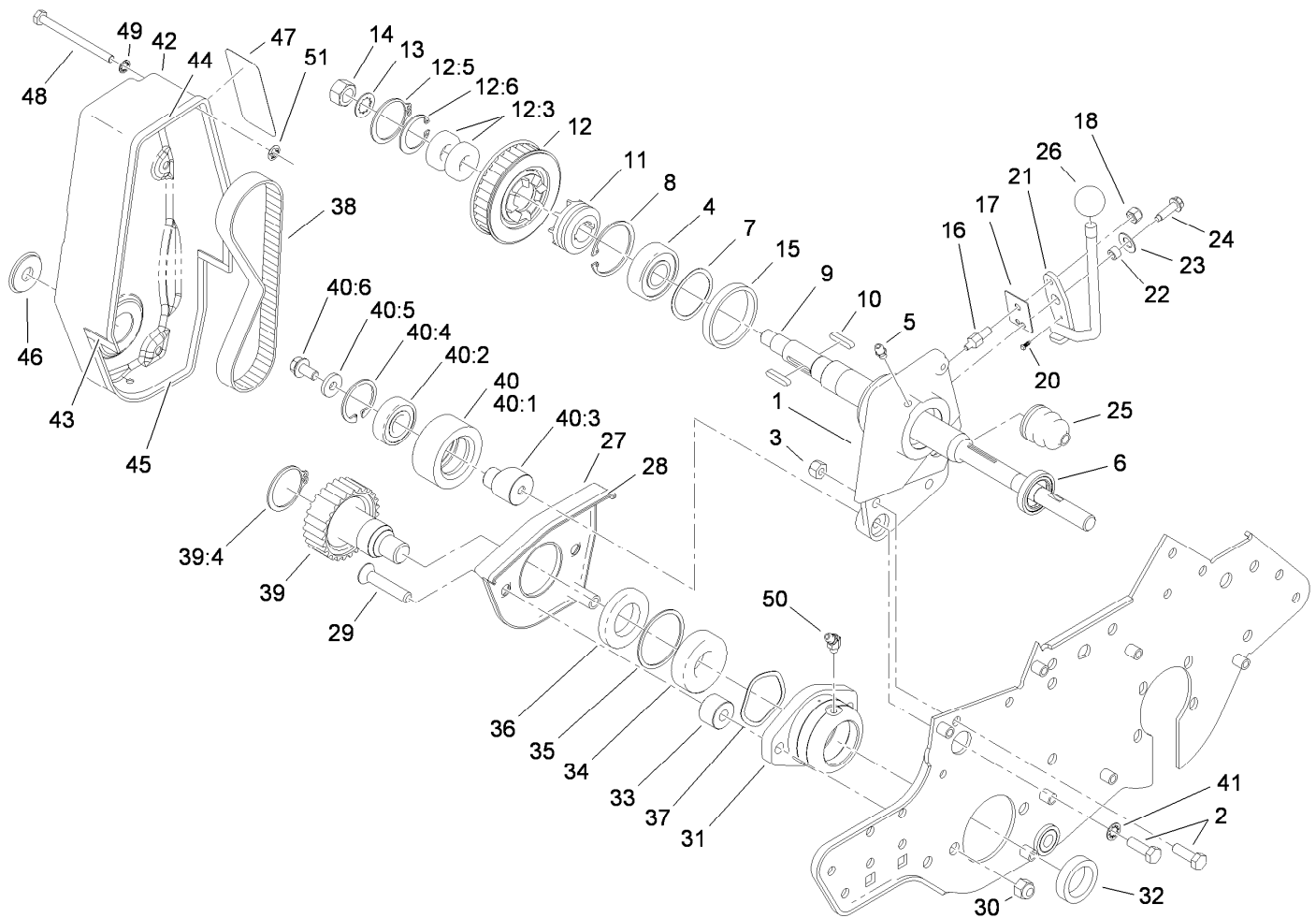

## Reel Drive Assembly

Ref.	Part Number	Qty.	Description	Ref.	Part Number	Qty.	Description
1	92-8013	1	Housing-Clutch	27	65-7190-01	1	Cover-Arm
2	322-5	3	Screw-HH	28	65-7131	1	Seal-Cover, Strip
3	3296-29	2	Nut-Lock, NI	29	3289-23	2	Capscrew
4	251-318	1	Bearing-Ball	30	3296-39	2	Nut-Lock, NI
5	302-5	1	Fitting-Grease	31	65-8640	1	Housing-Bearing
6	253-118	1	Seal-Oil	32	253-96	1	Seal-Oil
7	88-7720	1	Spring-Wave	33	65-8290	2	Standoff-Cover
8	32151-75	1	Ring-Retaining	34	251-342	1	Bearing-Ball
9	93-6056	1	Shaft-Power	35	32151-92	1	Ring-Retaining
10	88-7150	2	Key	36	253-163	1	Seal
11	65-6940	1	Clutch-Slider, Jaw	37	3290-485	1	Washer-Wave
12	88-7830	1	Clutch And Pulley ASM	38	65-6200	1	Belt
12:3	251-336	2	Bearing-Ball	39	88-7840	1	Pulley And Drive ASM
12:5	32151-95	1	Ring-Retaining	39:4	32151-95	1	Ring-Retaining
12:6	32151-89	1	Ring-Retaining, Bowed	40	88-7850	1	Idler Pulley ASM
13	3254-4	1	Washer-Lock/Int	40:1	88-7180	1	Pulley-Idler
14	3219-5	1	Nut-Hex	40:2	38-7820	1	Bearing-Ball
15	65-6970	1	Seal-Felt	40:3	88-7190	1	Spacer
16	93-9014	1	Pin-Clutch, Actuator	40:4	32120-42	1	Ring-Retaining
17	65-6290	1	Spring-Detent, Clutch	40:5	88-7200	1	Washer-Flat
18	3296-42	1	Nut-Lock, NI	40:6	3234-14	1	Screw-HHF
20	95-5731	1	Screw-Drive	41	3254-2	1	Washer-Lock, Internal
21	88-7170	1	Lever-Clutch	42	88-7700-01	1	Cover-Drive, Reel
22	88-7860	1	Spacer	43	88-7770	2	Strip-Seal, Front
23	3290-414	1	Washer-Belleville	44	88-7790	1	Strip-Seal, Upper
24	80-0700	1	Screw-HH, Torx	45	88-7800	1	Strip-Seal, Lower
25	65-8960	1	Boot-Clutch	46	237-160	1	Plug-Rubber
26	233-69	1	Knob				

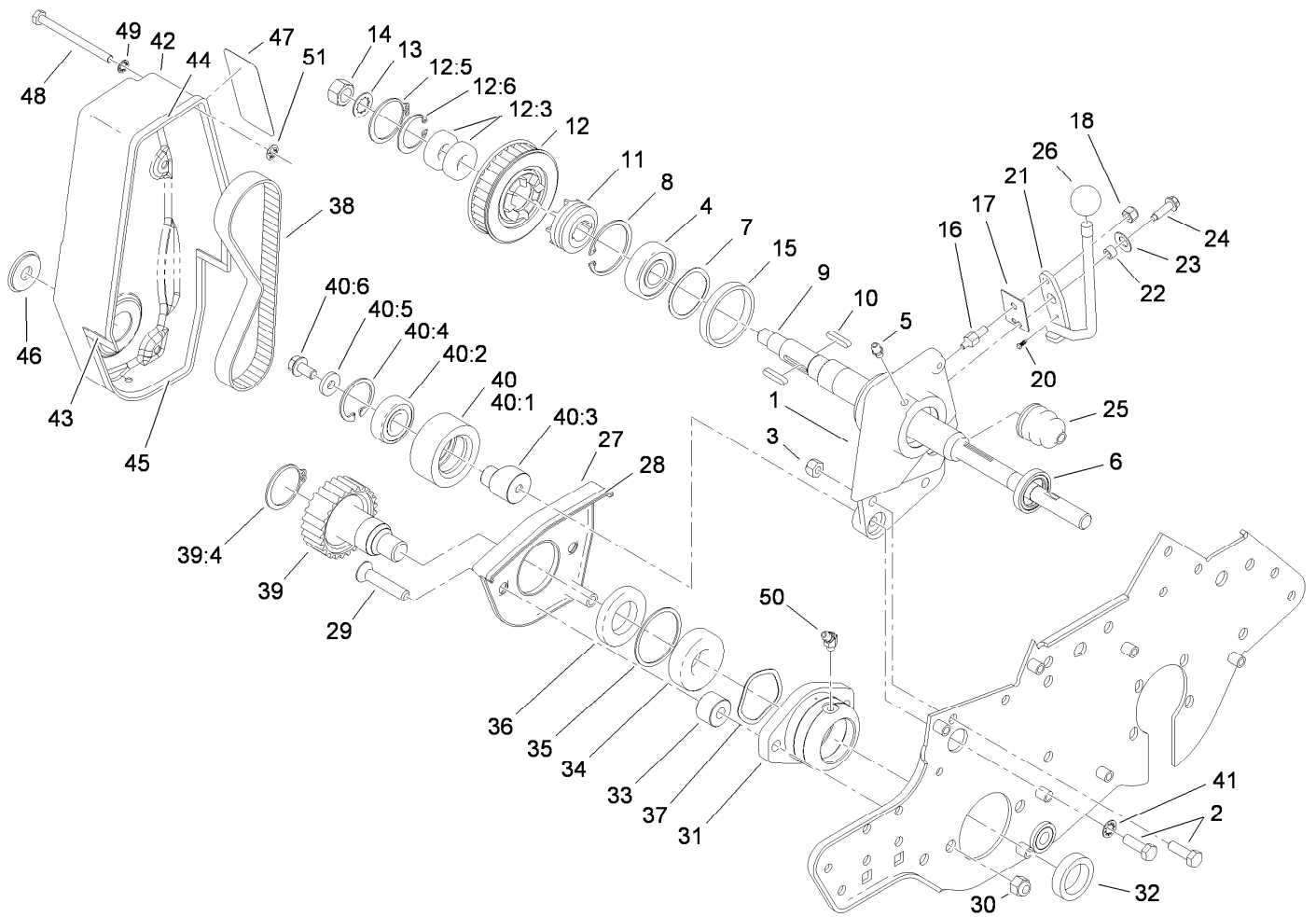

## Reel Drive Assembly (continued)

Ref.	Part Number	Qty.	Description
47	92-4817	1	Decal-Engagement, Reel (Japan)
47	93-7346	1	Decal-Engagement, Reel
48	321-20	4	Screw-HH

Ref.	Part Number	Qty.	Description
49	3254-8	4	Washer-Lock
50	302-11	1	Fitting-Lube, 45 DEG
51	106-8737	4	Nut-Retainer

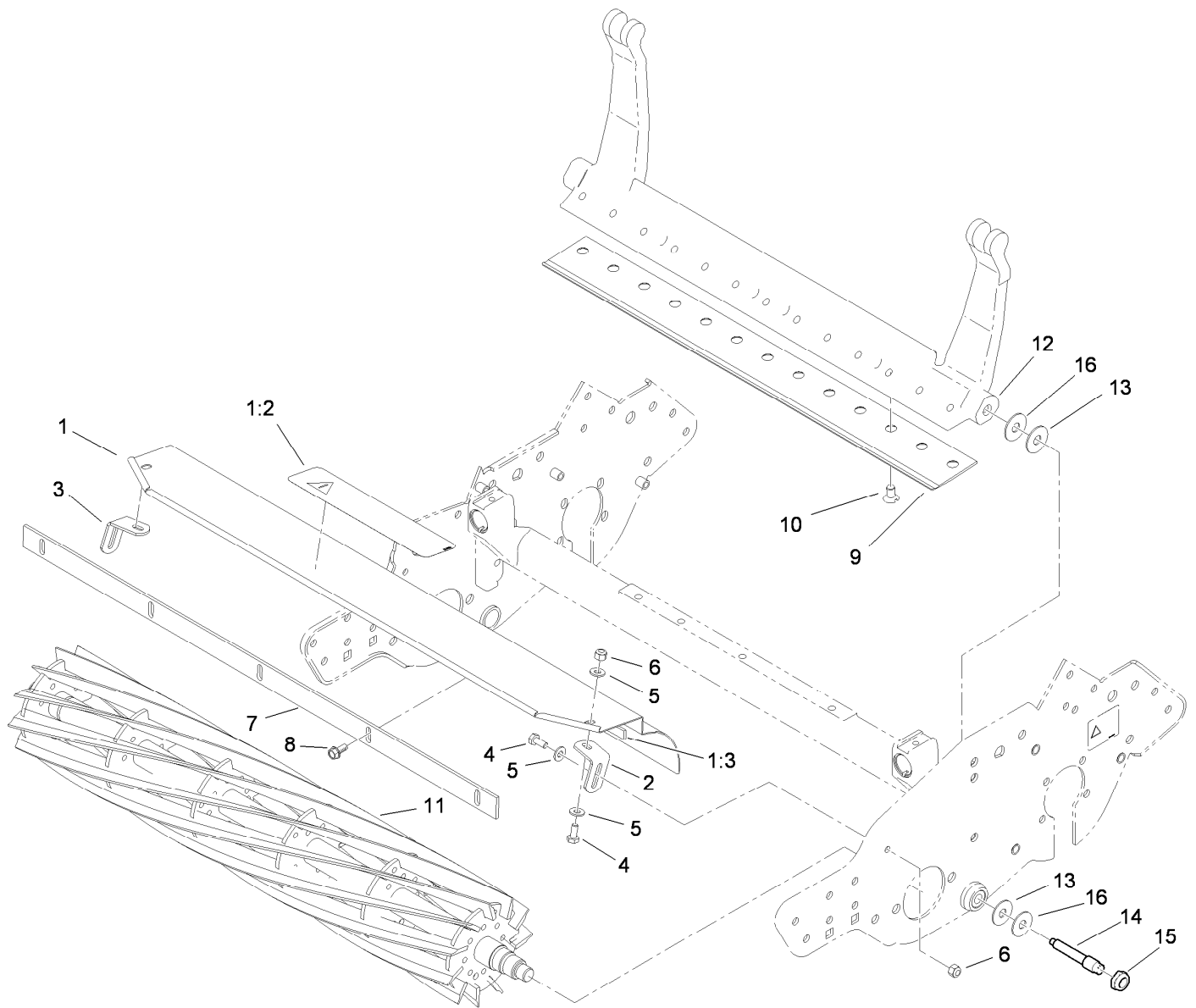

## Reel Assembly

Ref.	Part Number	Qty.	Description	Ref.	Part Number	Qty.	Description
1	112-9471	1	Grass Shield ASM	8	104-2065	5	Screw-HWH
1:2	84-6560	1	Decal-Warning (Japan)	9	93-4263	1	Bedknife-Tournament Cut
1:2	93-8064	1	Decal-Danger, Ce	10	57-4910	13	Screw-Special
1:3	106-2619	1	Strip-Seal	11	93-6097	1	11 Blade Reel ASM
2	65-6450	1	Bracket-LH	12	112-9281-01	1	Bedbar-Standard
3	65-6460	1	Bracket-RH	13	52-2900	4	Washer-Plastic
4	321-3	4	Screw-HH	14	117-9493	2	Bolt-Bedbar
5	3256-22	6	Washer-Flat	15	3296-28	2	Nut-Lock, NI
6	3296-42	4	Nut-Lock, NI	16	52-2860	4	Washer
7	36-7260	1	Bar-Off, Cut				

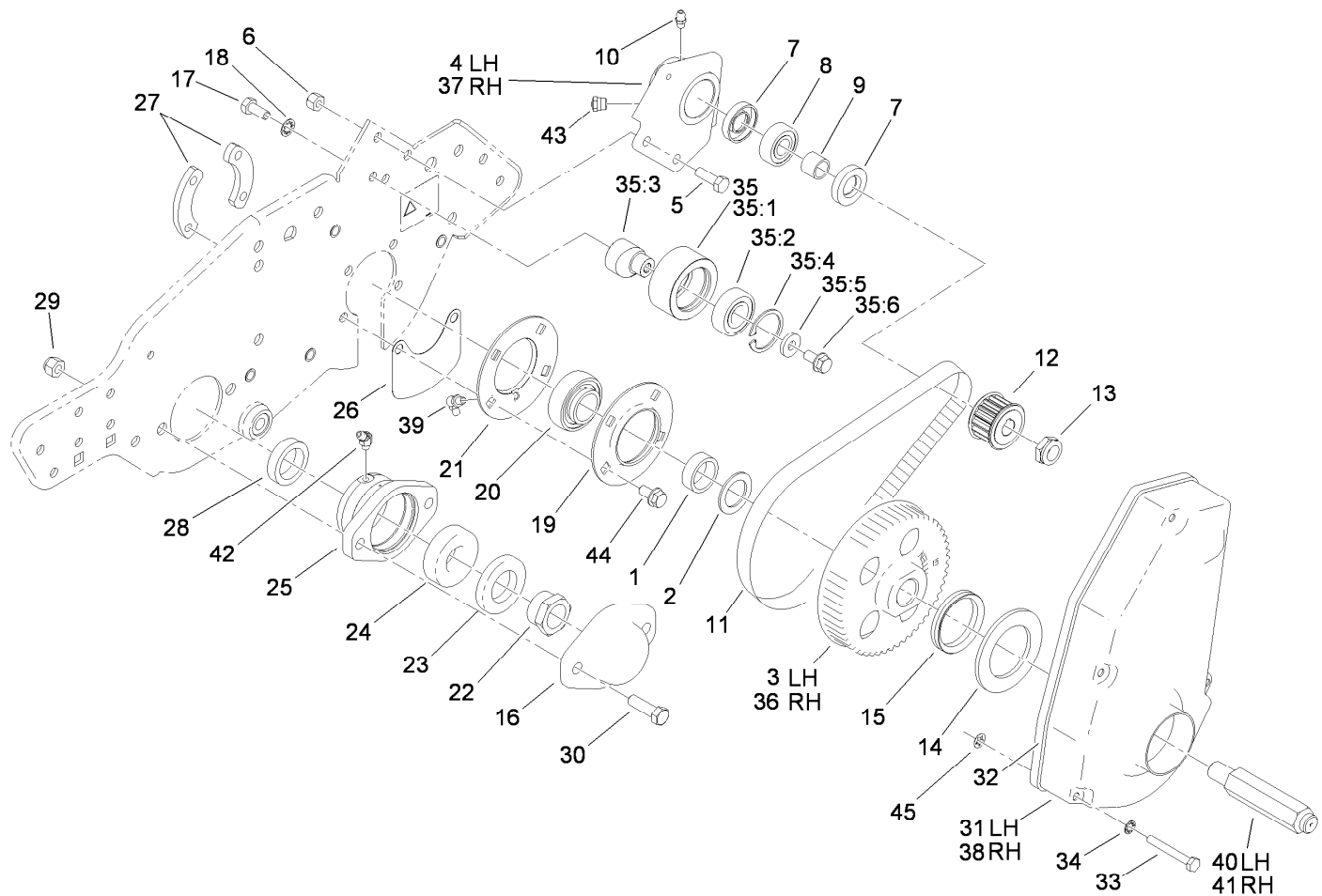

## Drum Drive Assembly

<i>Ref.</i>	<i>Part Number</i>	<i>Qty.</i>	<i>Description</i>	<i>Ref.</i>	<i>Part Number</i>	<i>Qty.</i>	<i>Description</i>
1	88-7530	2	Spacer	21	95-0923	2	Flangette
2	88-7540	2	Washer-Backup	22	92-7302	1	Nut-Bearing, Lock
3	105-5365	1	Pulley-Drum, LH	23	253-163	1	Seal
4	108-9414	1	Housing-Support, Differential (LH)	24	251-342	1	Bearing-Ball
5	322-5	4	Screw-HH	25	65-8640	1	Housing-Bearing
6	3296-29	4	Nut-Lock, NI	26	65-8720	2	Closure-Plate, Side
7	253-160	4	Seal-Grease	27	65-8730	4	Clamp-Bearing
8	251-338	2	Bearing-Ball	28	253-96	1	Seal-Oil
9	86-7130	2	Spacer-Pulley	29	3296-39	2	Nut-Lock, NI
10	302-5	2	Fitting-Grease	30	323-7	2	Screw-HH
11	65-6210	2	Belt	31	88-7680-01	1	Cover-Belt Drum, LH
12	65-6660	2	Pulley	32	88-7810	2	Seal-Strip, Drum Cover
13	3296-57	2	Nut-Lock, NI	33	321-11	8	Screw-HH
14	94-9018	2	Washer-Plastic	34	3254-8	8	Washer-Lock
15	253-161	2	Seal-V-Ring	35	88-7850	2	Idler Pulley ASM
16	65-6220-01	1	Cover-End, Reel	35:1	88-7180	1	Pulley-Idler
17	322-3	2	Screw-HH	35:2	38-7820	1	Bearing-Ball
18	3254-2	2	Washer-Lock, Internal	35:3	88-7190	1	Spacer
19	65-6590	2	Flangette-Bearing	35:4	32120-42	1	Ring-Retaining
20	88-7880	2	Bearing	35:5	88-7200	1	Washer-Flat
				35:6	3234-14	1	Screw-HHF

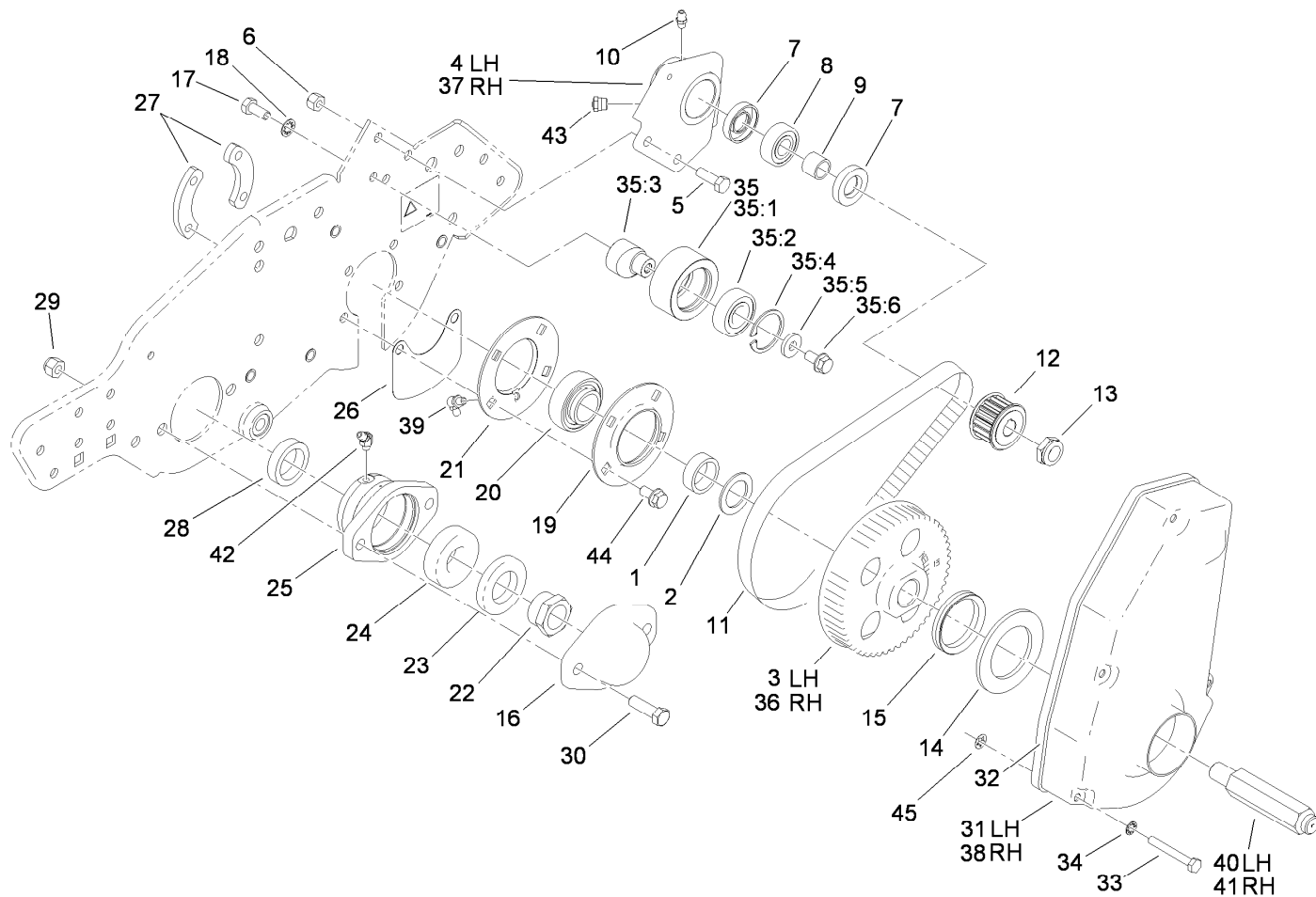

## Drum Drive Assembly (continued)

<i>Ref.</i>	<i>Part Number</i>	<i>Qty.</i>	<i>Description</i>	<i>Ref.</i>	<i>Part Number</i>	<i>Qty.</i>	<i>Description</i>
36	105-5364	1	Pulley-Drum, RH	41	88-7590	1	Shaft-Wheel, Transport (RH)
37	108-9416	1	Housing-Support, Differential (RH)	42	302-11	1	Fitting-Lube, 45 DEG
38	88-7690-01	1	Cover-Drum, Belt (RH)	43	302-34	2	Fitting-Lube
39	104-1843	2	Fitting-Grease, 90 DEG	44	3234-14	8	Screw-HHF
40	88-7580	1	Shaft-Wheel, Transport (LH)	45	106-8737	8	Nut-Retainer

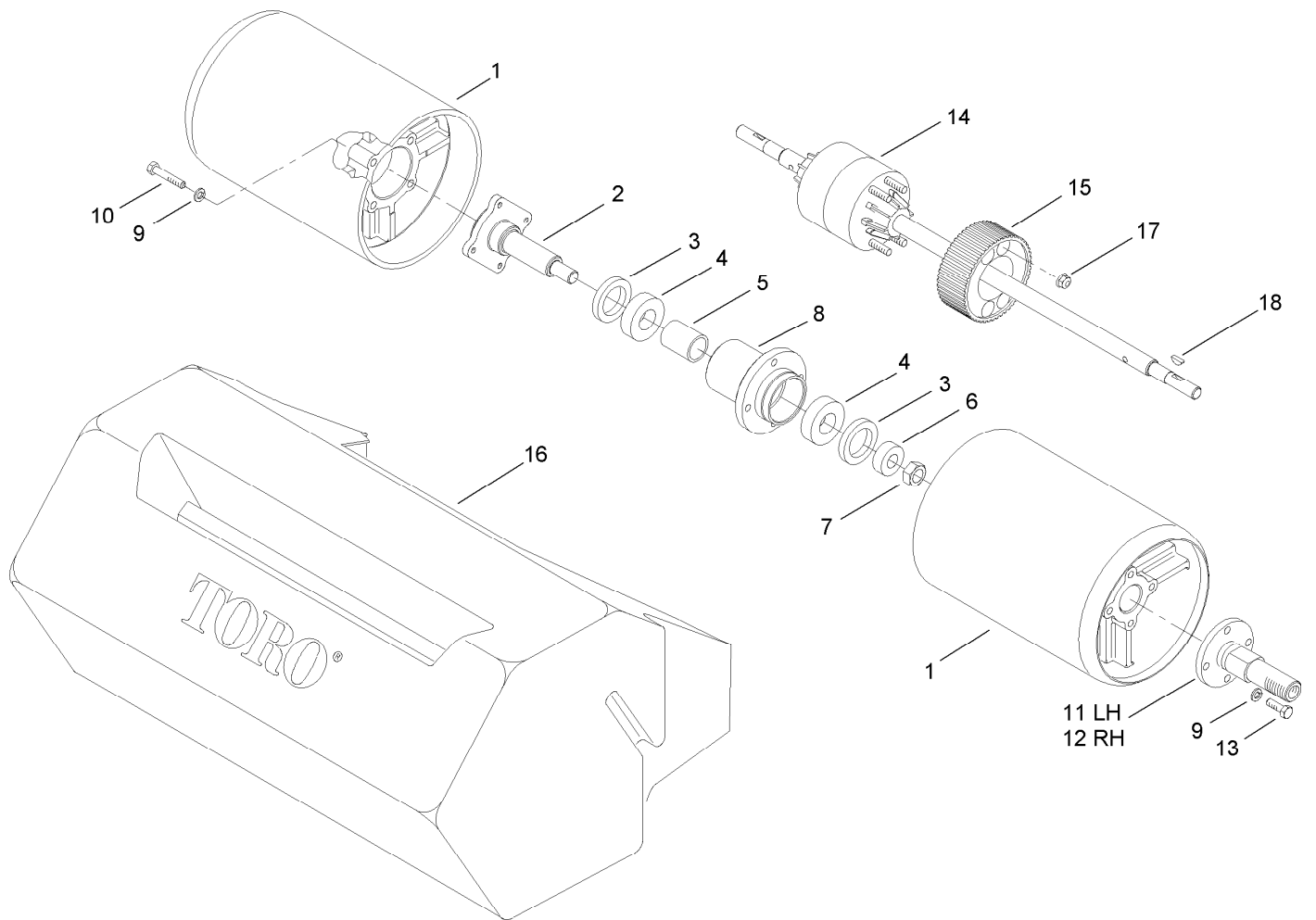

## Drum and Basket Assembly

Ref.	Part Number	Qty.	Description
1	93-9047	2	Drum
2	94-5850	1	Spindle-Drum
3	253-159	2	Seal
4	251-82	2	Bearing-Ball
5	65-6520	1	Spacer
6	65-6530	1	Spacer
7	3296-33	1	Nut-Lock, NI
8	94-5852	1	Hub-Drum
9	3253-4	16	Washer-Lock
10	322-9	8	Screw-HH
11	88-7520	1	Shaft-Extension, Drum (LH)
12	88-7510	1	Shaft-Extension, Drum (RH)
13	322-5	8	Screw-HH
14	93-6055	1	Differential ASM
15	65-9120	1	Pulley-Housing, Differential
16	65-7230	1	Basket-Grass
17	104-8300	4	Nut-Flange, NI
18	3257-30	2	Key-Woodruff

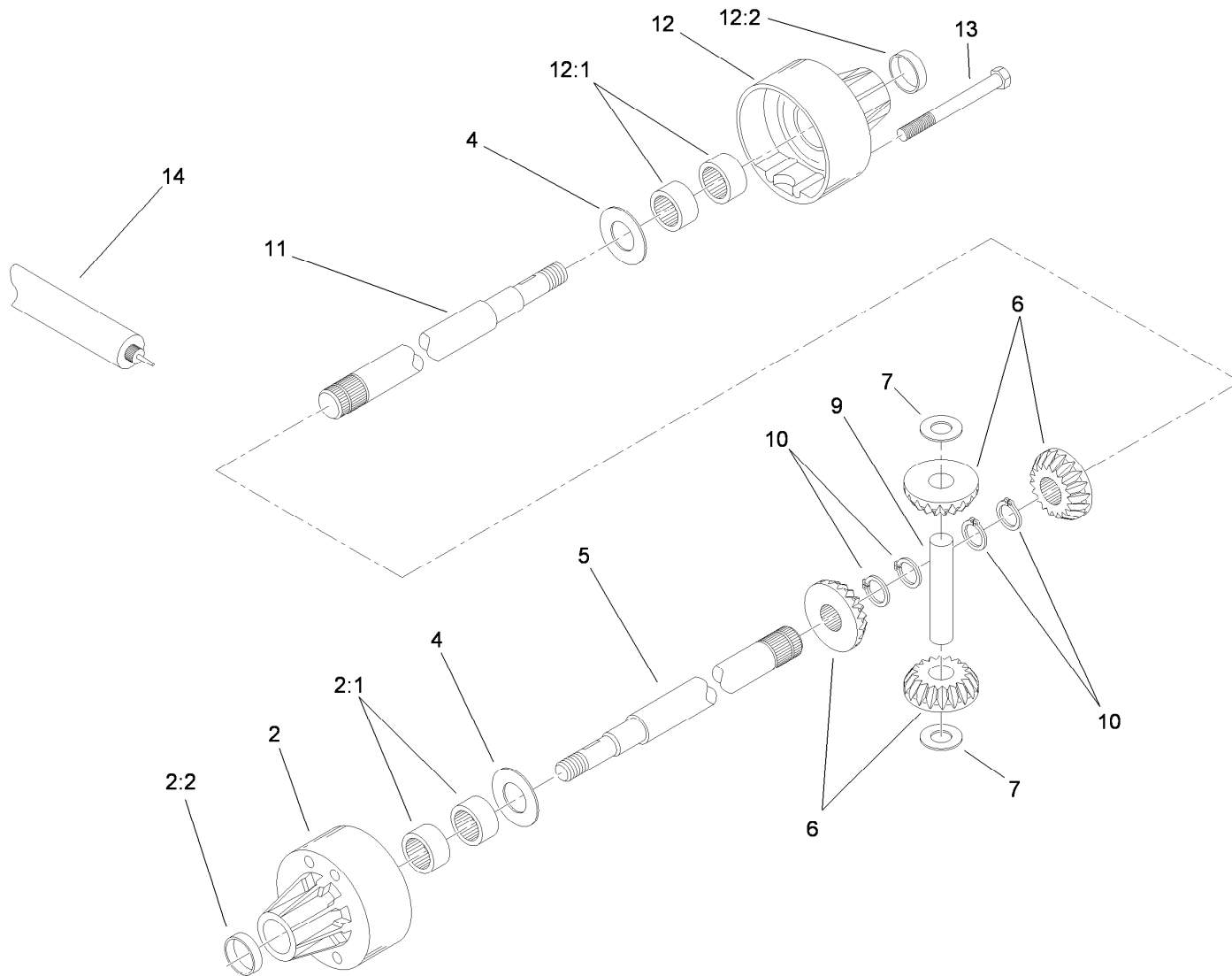

## Differential Assembly No. 93-6055

Ref.	Part Number	Qty.	Description
2	95-5741	1	Carrier-Differential
2:1	95-5738	4	Bearing-Needle
2:2	95-5737	2	Seal-Oil
4	95-5745	4	Washer
5	95-5736	1	Axle (Long)
6	104-0503	1	Gear Set-Differential
7	95-5744	2	Washer-Flat
9	95-5747	1	Pin-Drive
10	95-5746	4	Ring-Retaining
11	95-5735	1	Axle (Short)
12	95-5740	1	Carrier-Differential
12:1	95-5738	4	Bearing-Needle
12:2	95-5737	2	Seal-Oil
13	95-5739	4	Screw
14	95-5734	1	Grease

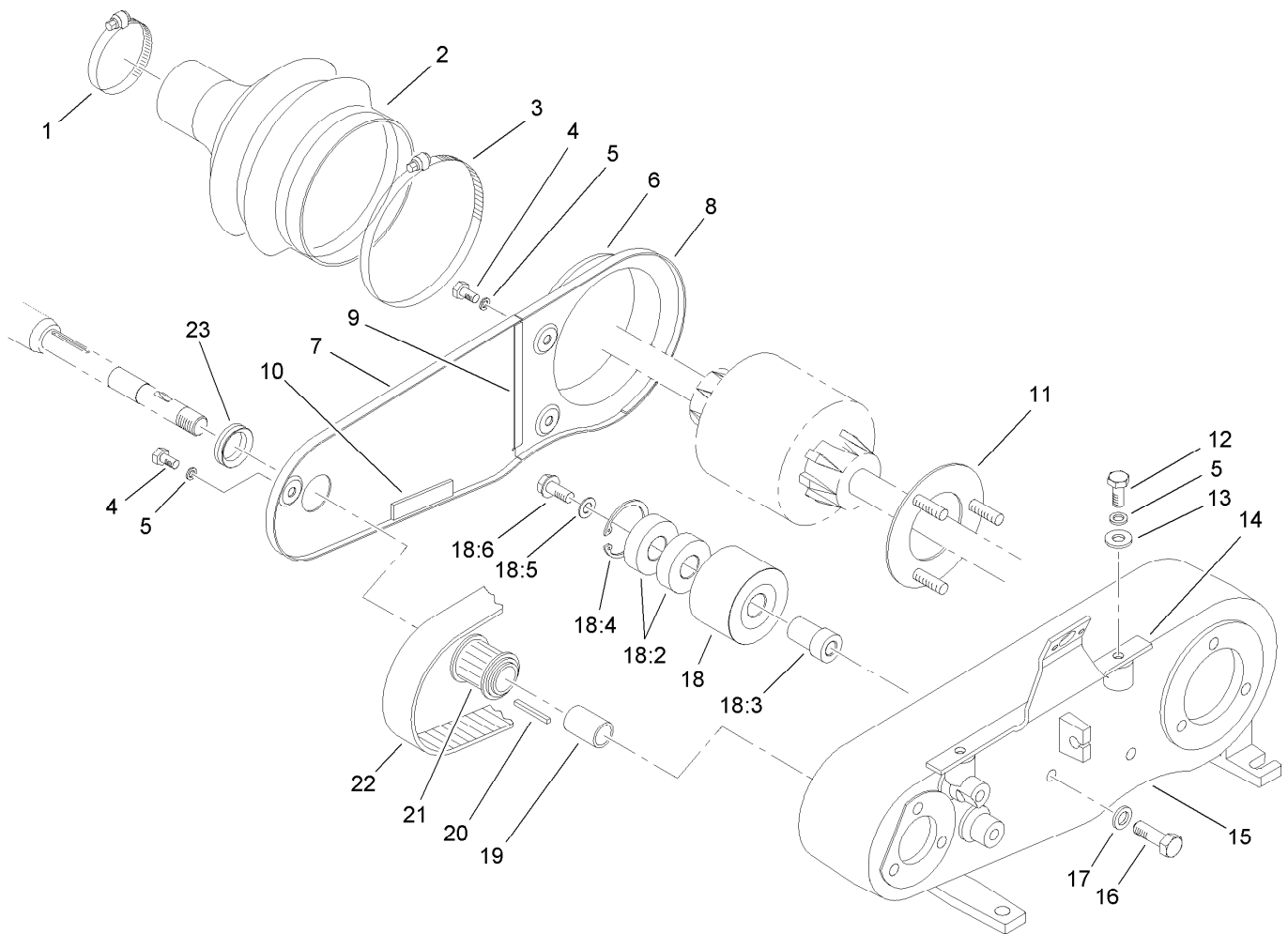

## Inner Countershaft Assembly

<i>Ref.</i>	<i>Part Number</i>	<i>Qty.</i>	<i>Description</i>	<i>Ref.</i>	<i>Part Number</i>	<i>Qty.</i>	<i>Description</i>
1	2412-139	1	Clamp-Hose	15	88-7230	1	Housing-Shaft, Counter
2	65-6800	1	Boot-Differential	16	322-5	1	Screw-HH
3	2412-140	1	Clamp-Hose	17	3254-2	1	Washer-Lock, Internal
4	321-2	3	Screw-HH	18	88-7870	1	Idler Pulley ASM
5	3253-3	5	Washer-Lock	18:2	38-7820	2	Bearing-Ball
6	88-7250-03	1	Cover-Box, Rear	18:3	88-7380	1	Spacer-Pulley
7	88-7240-03	1	Cover-Box, Front	18:4	32120-42	1	Ring-Retaining
8	65-6902	1	Strip-Seal, Cover	18:5	88-7200	1	Washer-Flat
9	65-6903	1	Strip-Seal, Cover	18:6	3234-14	1	Screw-HHF
10	65-6901	1	Strip-Seal, Cover	19	86-7140	1	Spacer
11	65-6720	1	Plate-Screw	20	65-6850	1	Key-Square
12	321-3	2	Screw-HH	21	65-8910	1	Pulley-Countershaft
13	3256-22	2	Washer-Flat	22	65-9080	1	Belt
14	93-1448	1	Bracket Cover ASM	23	88-7710	1	Seal-V-Ring

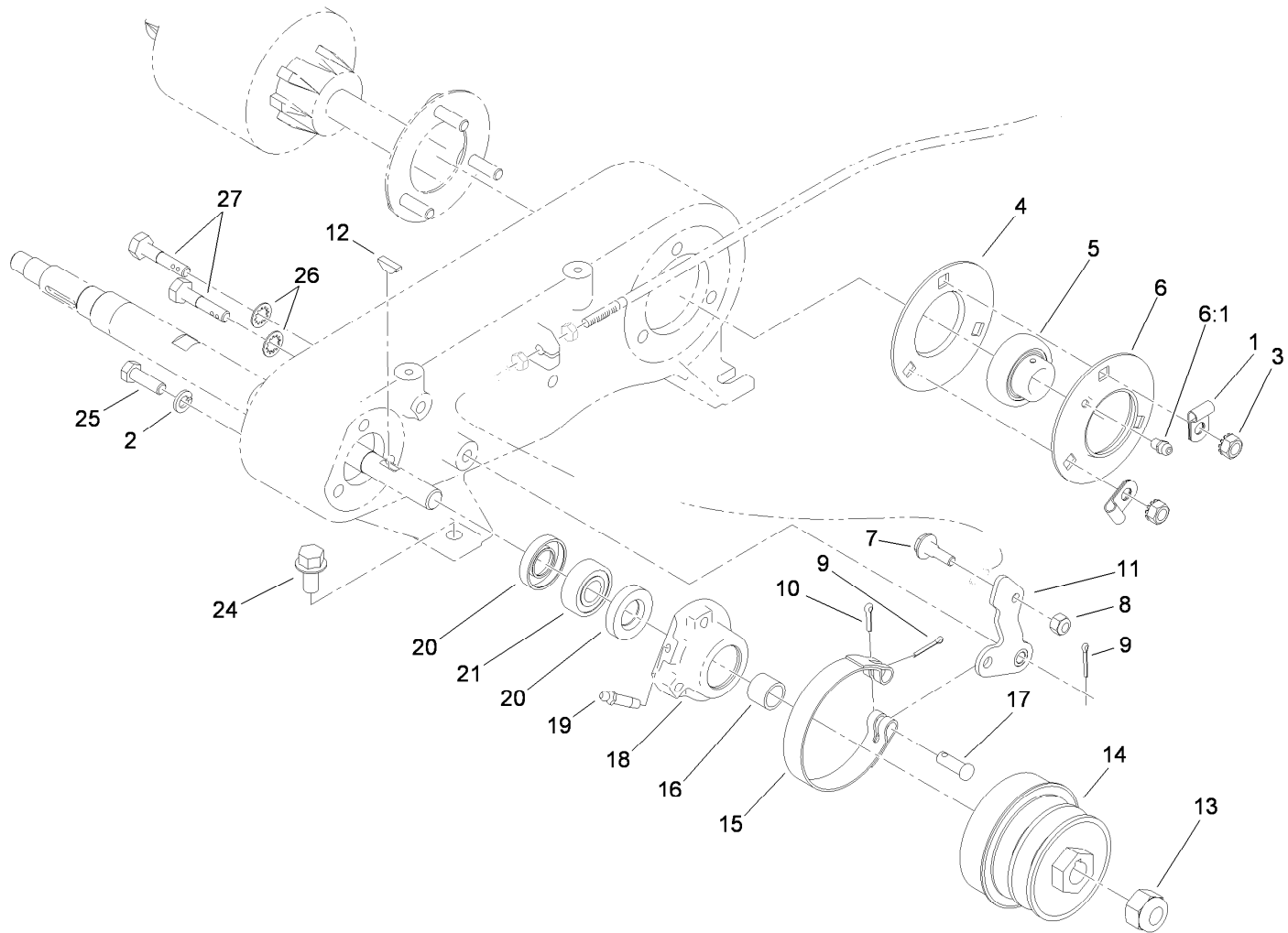

## Outer Crankshaft Assembly

<i>Ref.</i>	<i>Part Number</i>	<i>Qty.</i>	<i>Description</i>	<i>Ref.</i>	<i>Part Number</i>	<i>Qty.</i>	<i>Description</i>
1	88-7970	2	Clip	13	3296-63	1	Nut-Lock, NI
2	3253-4	3	Washer-Lock	14	92-9212	1	Pulley-Shaft, Input
3	32149-1	3	Nut-Keps	15	65-8700	1	Band-Brake
4	65-6710	1	Flangette-Bearing	16	86-7130	1	Spacer-Pulley
5	108-7663	1	Bearing-Race, Extended	17	283-75	1	Pin-Clevis
6	65-6700	1	Flangette-Lube	18	65-6760	1	Housing-Bearing
6:1	302-55	1	Fitting-Grease	19	302-64	1	Fitting-Grease
7	11-9030	1	Screw-Shoulder	20	253-160	2	Seal-Grease
8	3296-42	1	Nut-Lock, NI	21	251-338	1	Bearing-Ball
9	3272-6	2	Pin-Cotter	24	3234-1	4	Screw-HHF
10	3272-8	1	Pin-Cotter	25	322-5	3	Screw-HH
11	117-1433	1	Lower Brake Lever ASM	26	3254-6	2	Washer-Lock, Internal
12	3257-30	1	Key-Woodruff	27	117-1430	2	Bolt-Mount, Brake

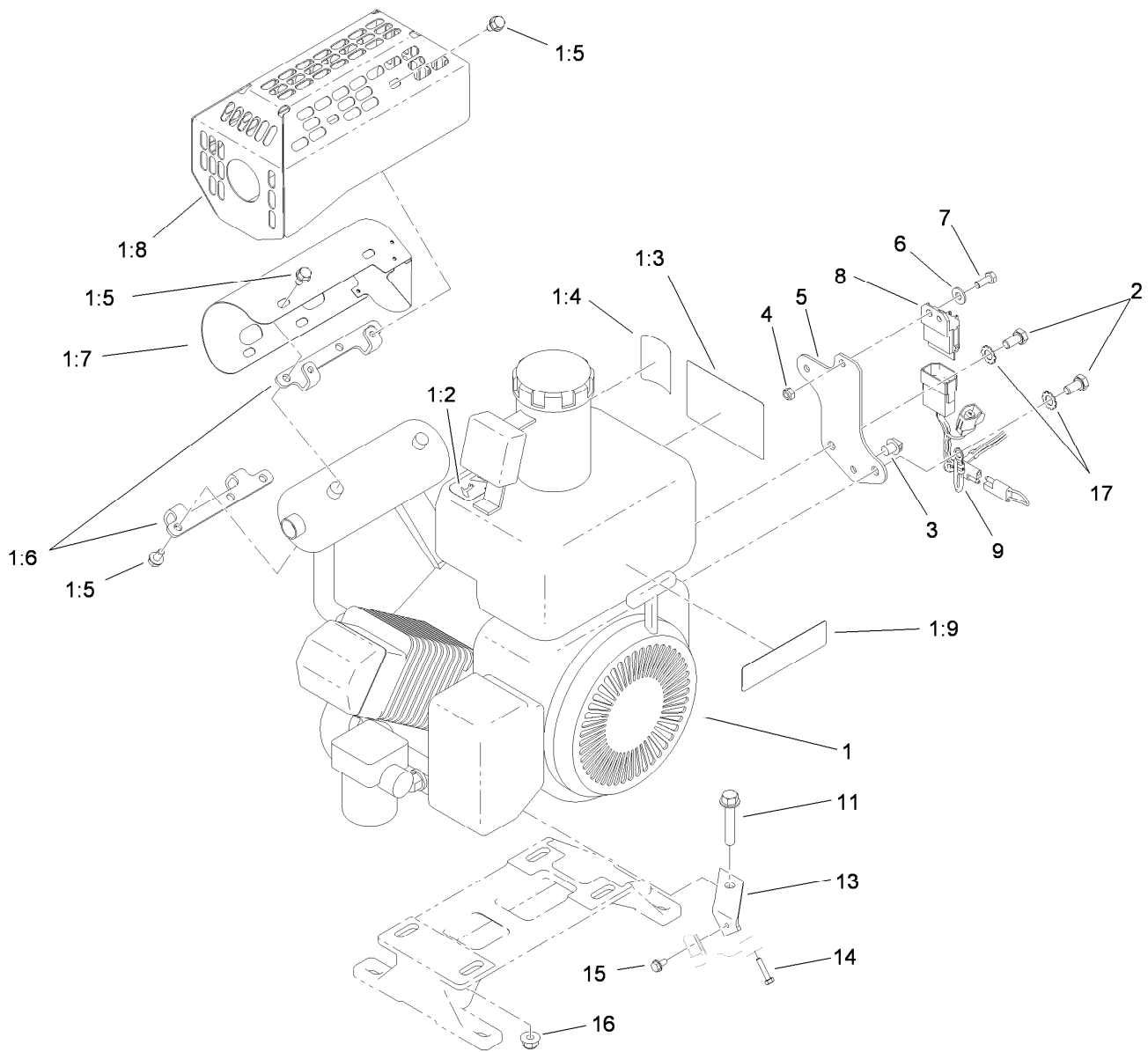

## Engine Assembly

<i>Ref.</i>	<i>Part Number</i>	<i>Qty.</i>	<i>Description</i>	<i>Ref.</i>	<i>Part Number</i>	<i>Qty.</i>	<i>Description</i>
1	117-1465	1	Engine ASM	5	117-1365-03	1	Plate-Harness, Wire
1:2	115-1615	1	Decal-Surface, Hot	6	3256-22	1	Washer-Flat
1:3	115-1613	1	Decal-Danger	7	33113-016	1	Screw-HH
1:4	93-9886	1	Decal-Fuel	8	1-323430	1	Module-Interlock
1:5	104-2628	8	Screw-HWH	9	115-1610	1	Harness-Wire
1:6	104-9771	2	Bracket-Guard, Muffler	11	94-5780	4	Screw-HWH
1:7	112-9360	1	Shield-Muffler, Inner	13	88-7960	1	Bracket-Cable, Throttle
1:8	112-9361-03	1	Guard-Muffler	14	94-9015	1	Screw-HH
1:9	117-2718	1	Decal-Arrester, Spark	15	104-2065	1	Screw-HWH
2	33114-016	2	Screw-HH	16	104-8300	4	Nut-Flange, NI
3	32180-030	1	Clip-Harness	17	3255-9	2	Washer-Lock
4	33023-00	1	Nut-Lock				

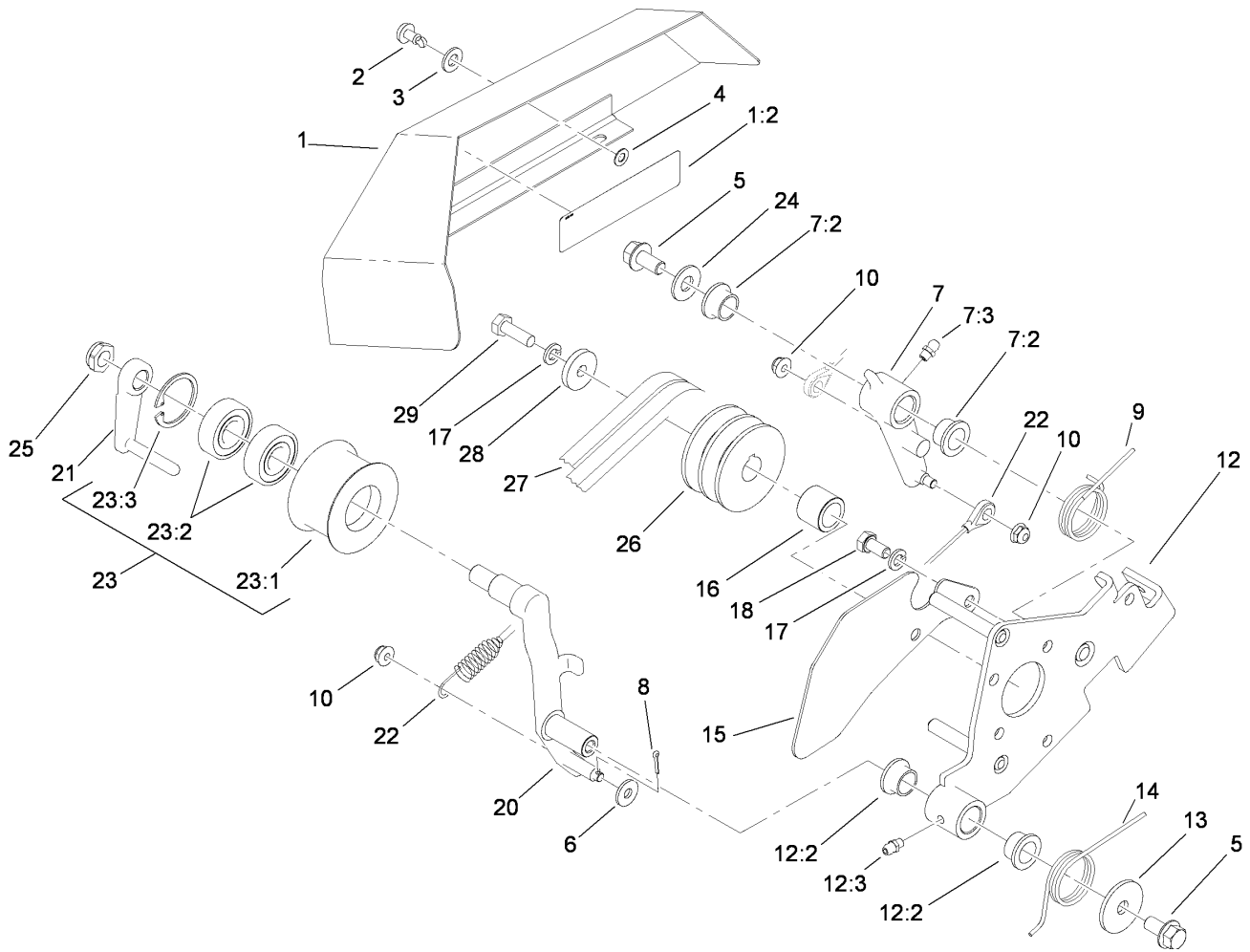

## Bellcrank Assembly

<i>Ref.</i>	<i>Part Number</i>	<i>Qty.</i>	<i>Description</i>	<i>Ref.</i>	<i>Part Number</i>	<i>Qty.</i>	<i>Description</i>
1	94-9007	1	Bellcrank Cover ASM	14	93-6012	1	Spring-Torque, Clutch Lever
1:2	84-7280	1	Decal-Danger, Japan	15	93-6013-03	1	Shield-Belt
1:2	93-7273	1	Decal-Danger	16	65-8260	1	Spacer-Shaft, Engine
2	93-6074	1	Stud	17	3253-4	6	Washer-Lock
3	3256-70	1	Washer-Flat	18	33114-016	5	Screw-HH
4	93-6073	1	Washer-Nylon	20	112-9392	1	Lever-Clutch
5	110-1718	2	Screw-HHF	21	112-9390	1	Guide-Belt
6	3256-78	1	Washer-Flat	22	93-9024	1	Cable Link ASM
7	112-9388	1	Traction Lever ASM	23	112-9385	1	Idler Pulley ASM
7:2	65-8770	2	Bushing-Bellcrank	23:1	98-7297	1	Pulley-Idler
7:3	302-5	1	Fitting-Grease	23:2	38-7820	2	Bearing-Ball
8	3272-5	1	Pin-Cotter	23:3	32120-42	1	Ring-Retaining
9	93-6011	1	Spring-Torsion	24	3256-4	1	Washer-Flat
10	104-7201	3	Nut-HF	25	3296-45	1	Nut-Lock, NI
12	112-9398	1	Clutch Bracket ASM	26	92-9216	1	Pulley-Drive, Input
12:2	65-8770	2	Bushing-Bellcrank	27	92-9218	1	Belt-V, Matched Set
12:3	302-5	1	Fitting-Grease	28	65-8270	1	Washer
13	93-6099	1	Washer	29	33114-025	1	Screw-HH

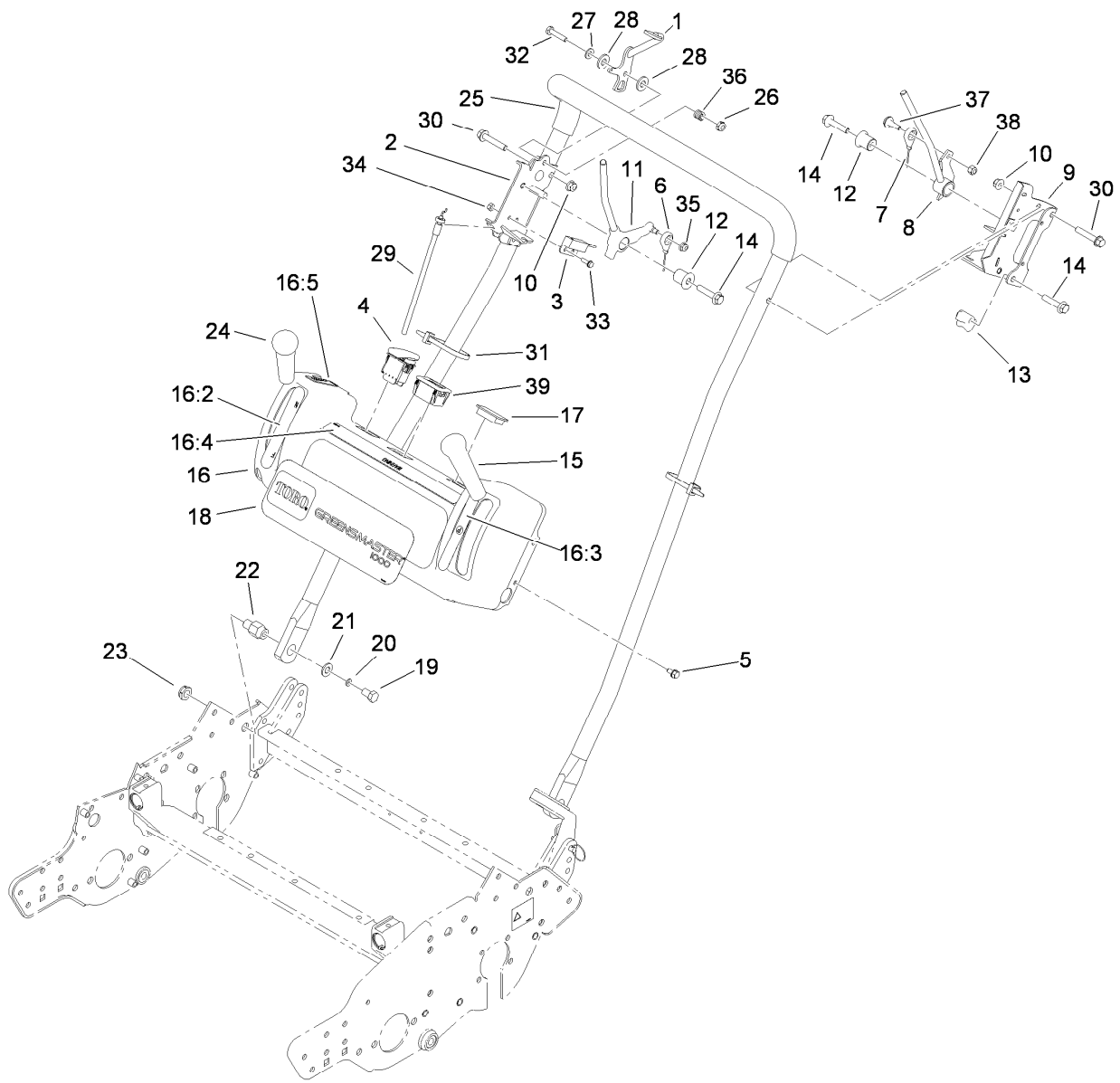

## Handle Assembly

Ref.	Part Number	Qty.	Description	Ref.	Part Number	Qty.	Description
1	115-1098	1	Throttle Lever ASM	18	115-1130	1	Decal-Console
2	115-1751-03	1	Traction Bracket ASM	19	323-34	2	Screw-HH
3	100-1270	1	Switch-Proximity	20	3253-21	2	Washer-Lock
4	112-9420	1	Switch-Engine	21	3256-24	2	Washer-Flat
5	104-2628	4	Screw-HWH	22	110-7364	2	Pin-Handle, Pivot
6	94-5870	1	Cable Clutch ASM	23	3296-28	2	Nut-Lock, NI
7	94-5871	1	Cable Brake ASM	24	104-9760	1	Knob-Black
8	115-1677	1	Brake Lever ASM	25	112-9478	1	Handle
9	115-1068-03	1	Brake Bracket ASM	26	3296-56	1	Nut-Lock, NI
10	104-8300	2	Nut-Flange, NI	27	3256-22	1	Washer-Flat
11	112-9321	1	Lever-Traction	28	66-2921	2	Washer-Friction
12	112-9317	2	Bushing-Flanged	29	115-1713	1	Cable-Throttle
13	110-2415	2	Clamp-Handle	30	94-5780	2	Screw-HWH
14	112-9318	4	Screw-HHF W/Lock	31	3290-378	4	Tie-Cable
15	104-9774	1	Knob-Red	32	321-8	1	Screw-HH
16	115-1124	1	Console ASM	33	115-1727	2	Screw-HHF
16:2	115-1720	1	Decal-Lever, Traction	34	1-804254	2	Nut
16:3	104-2618	1	Decal-Lever, Brake	35	104-7201	1	Nut-HF
16:4	115-1614	1	Decal-Warning	36	3-5787	1	Spring-Compression
16:5	93-6085	1	Decal-Throttle	37	11-9030	1	Screw-Shoulder
17	99-7420	1	Plug-Hole				

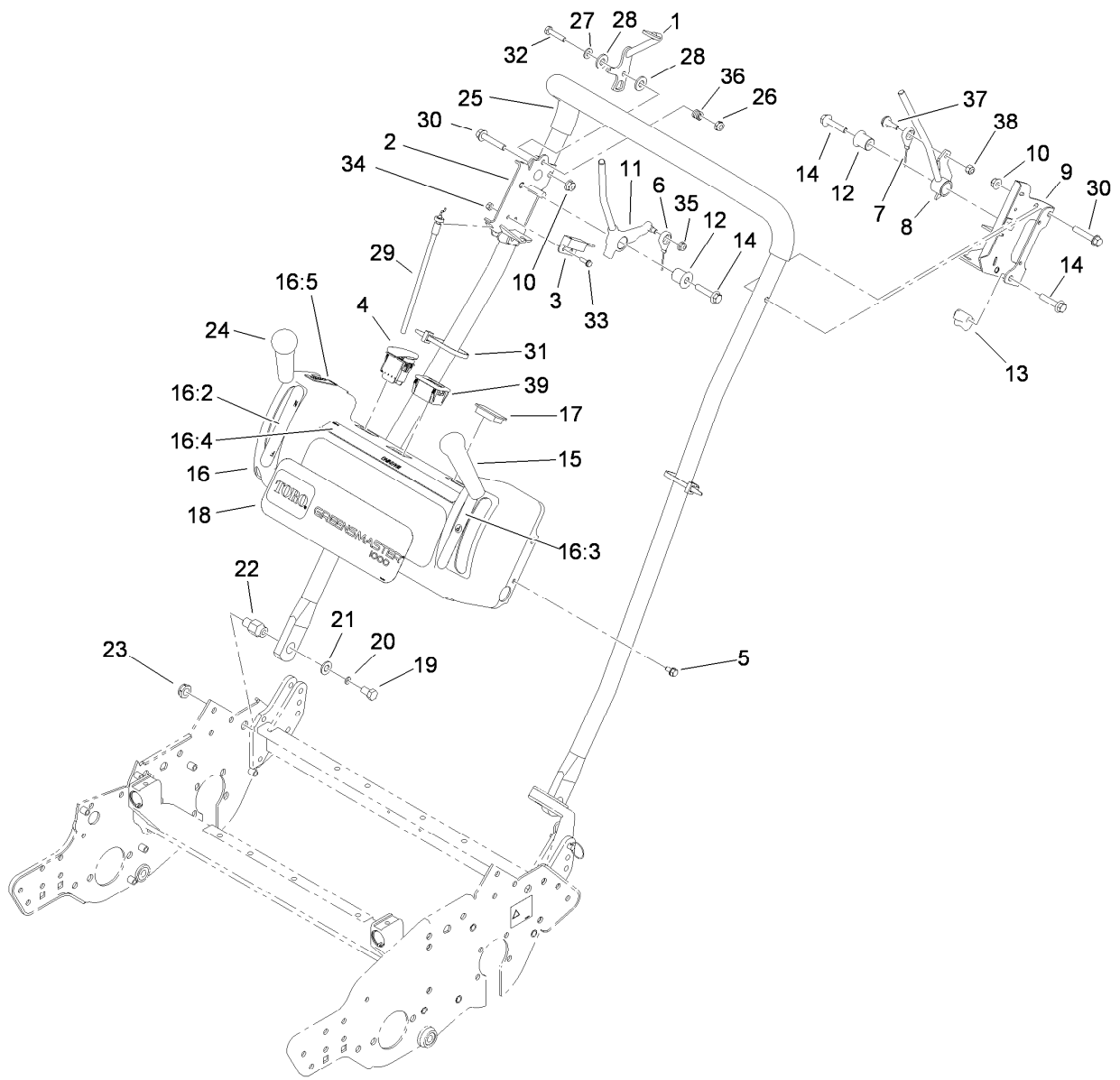

## Handle Assembly (continued)

<i>Ref.</i>	<i>Part Number</i>	<i>Qty.</i>	<i>Description</i>
38	3296-42	1	Nut-Lock, NI
39	119-1347	1	Meter-Hour

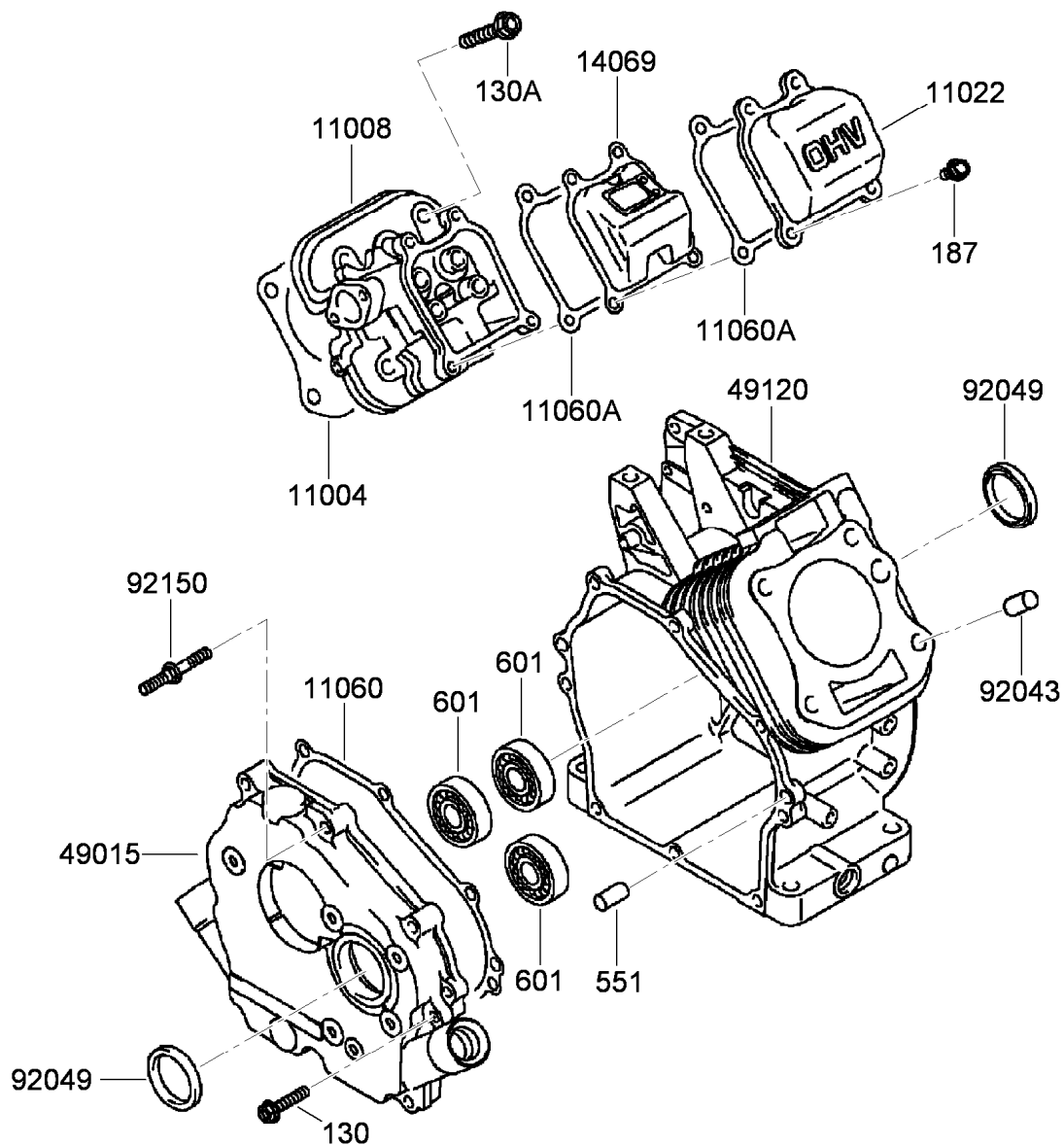

## Cylinder and Crankcase Assembly

<i>Ref.</i>	<i>Part Number</i>	<i>Qty.</i>	<i>Description</i>	<i>Ref.</i>	<i>Part Number</i>	<i>Qty.</i>	<i>Description</i>
130	108-2522	4	Bolt-Flanged (6X30)	11060	93-8525	1	Gasket-Cover, Crankcase
130A	115-1759	4	Bolt-Flanged (8X45)	11060A	93-8509	2	Gasket-Case, Rocker
187	115-1760	4	Bolt-Upset, Wsp (6X16)	14069	93-8510	1	Breather
551	93-8516	2	Pin-Dowel (6X12)	49015	93-8520	1	Cover-Crankcase
601	93-8517	3	Bearing-Ball	49120	93-8515	1	Crankcase
11004	93-8504	1	Gasket-Head	92043	93-8512	2	Pin
11008	115-1757	1	Head-Cylinder	92049	93-8511	2	Seal-Oil
11022	93-8508	1	Case-Rocker	92150	93-8524	1	Stud

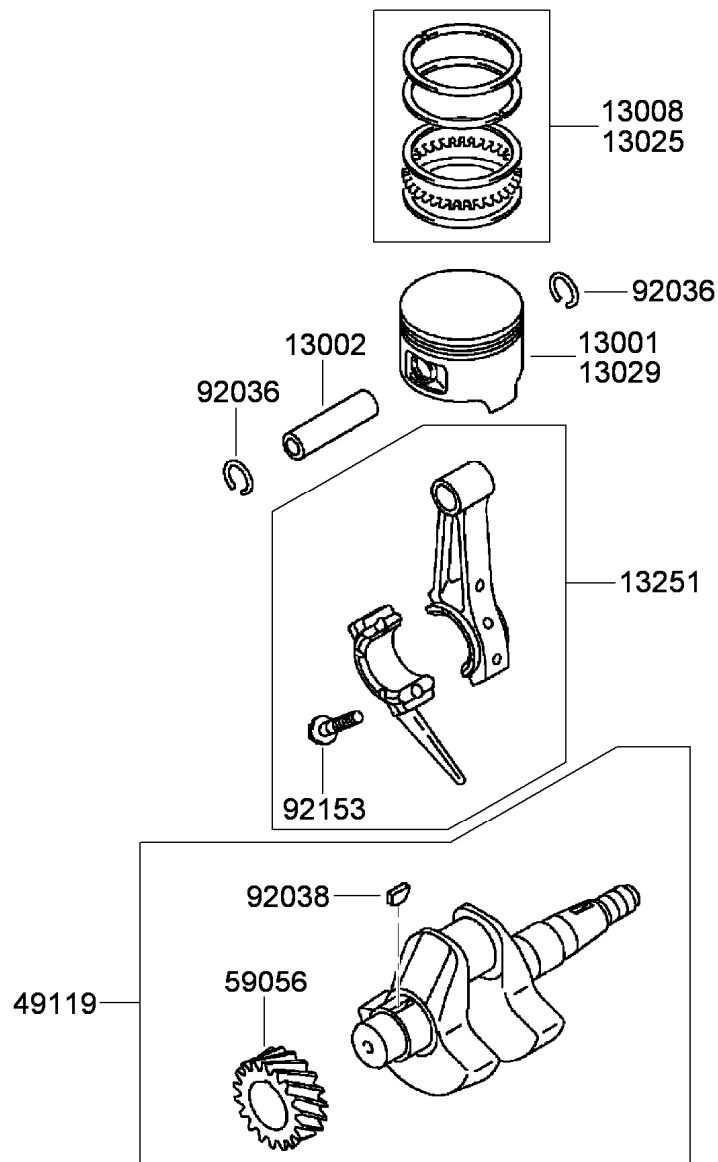

## Piston and Crankshaft Assembly

<i>Ref.</i>	<i>Part Number</i>	<i>Qty.</i>	<i>Description</i>
13001	93-8502	1	Piston
13002	93-8501	1	Pin-Piston
13008	93-8503	1	Set-Ring, Piston
13025	94-6837	1	Piston Ring Set (.05Mm)
13029	94-6836	1	Piston (0.5 O S)
13251	93-8528	1	Connecting Rod ASM
49119	93-8518	1	Crankshaft ASM
59056	94-9043	1	Gear-Helical
92036	93-8500	2	Ring-Retaining
92038	93-8698	1	Key
92153	115-1805	2	Bolt (6X30)

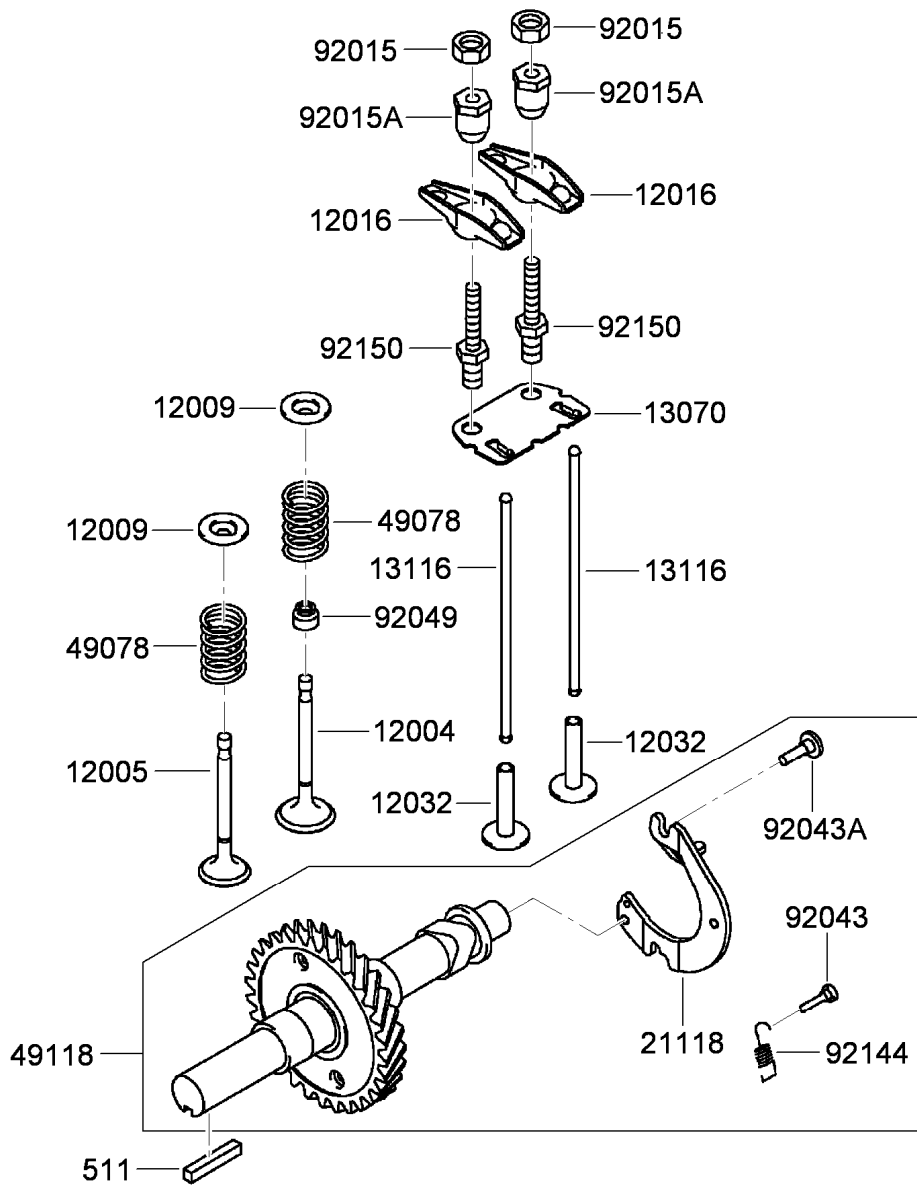

## Valve and Camshaft Assembly

<i>Ref.</i>	<i>Part Number</i>	<i>Qty.</i>	<i>Description</i>	<i>Ref.</i>	<i>Part Number</i>	<i>Qty.</i>	<i>Description</i>
511	108-9442	1	Key	49078	108-2533	2	Spring-Valve, Engine
12004	93-8532	1	Valve-Intake	49118	93-8544	1	Camshaft ASM
12005	93-8529	1	Valve-Exhaust	92015	93-8533	2	Nut
12009	93-8531	2	Retainer-Spring, Valve	92015A	93-8534	2	Nut
12016	93-8535	2	Arm-Rocker	92043	93-8542	1	Pin
12032	93-8539	2	Tappet	92043A	93-8540	2	Pin
13070	115-1758	1	Guide	92049	115-1762	1	Seal-Oil
13116	93-8538	2	Rod-Push	92144	93-8541	1	Spring
21118	93-8543	1	Decompressor	92150	93-8536	2	Bolt

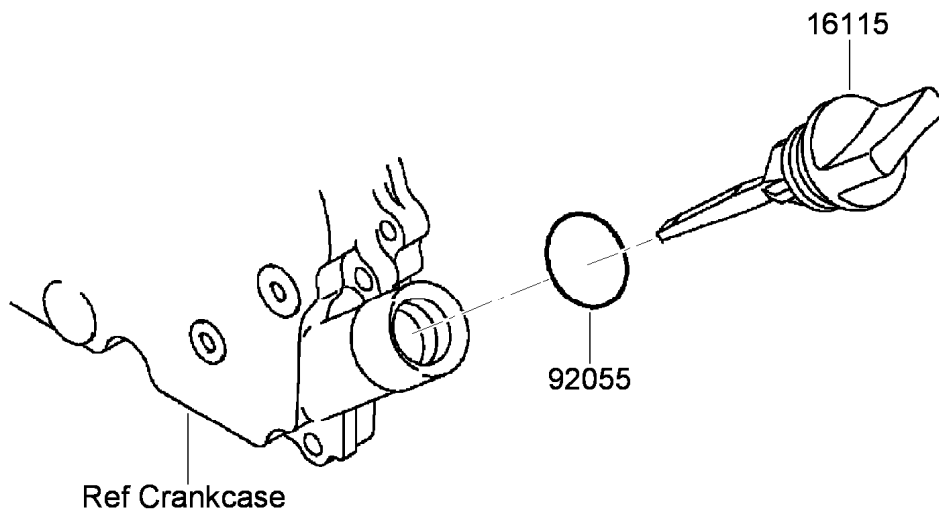
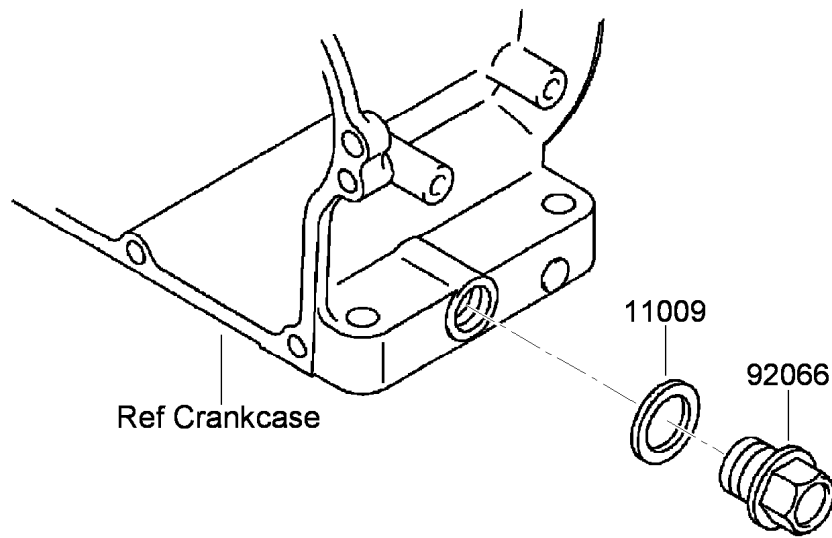

## Lubrication Equipment Assembly

<i>Ref.</i>	<i>Part Number</i>	<i>Qty.</i>	<i>Description</i>
11009	93-8514	2	Gasket-Plug, Drain (14.2X19X2)
16115	93-8523	2	Cap-Filler, Oil
92055	94-9041	2	O-Ring (20Mm)
92066	115-1761	2	Plug (14X12)

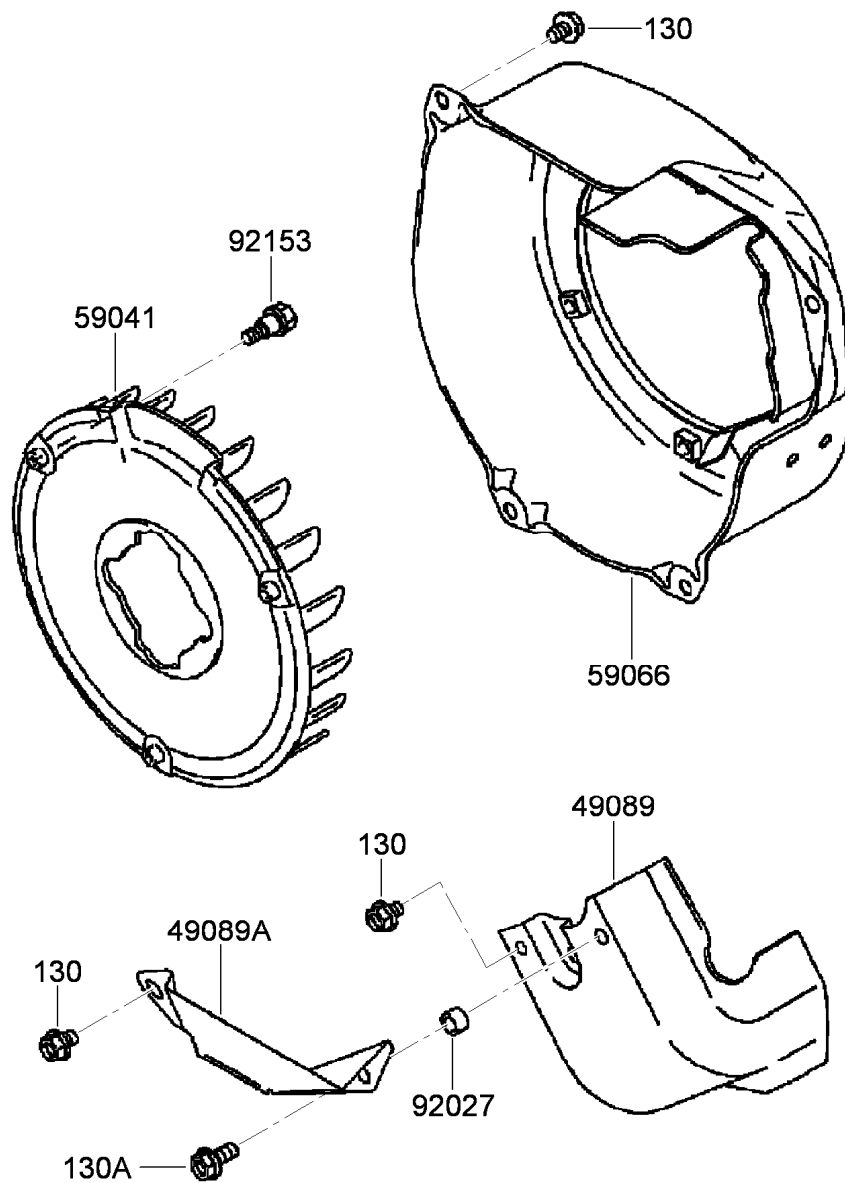

## Cooling Equipment Assembly

<i>Ref.</i>	<i>Part Number</i>	<i>Qty.</i>	<i>Description</i>
130	115-1765	7	Bolt-Flanged (6X8)
130A	115-1764	1	Bolt-Flanged (6X14)
49089	93-8563	1	Shroud-Engine
49089A	93-8565	1	Shroud-Engine
59041	93-8572	1	Fan
59066	115-1804	1	Housing-Fan
92027	93-8564	1	Collar (6.8X10X6)
92153	94-6840	3	Bolt-Flanged

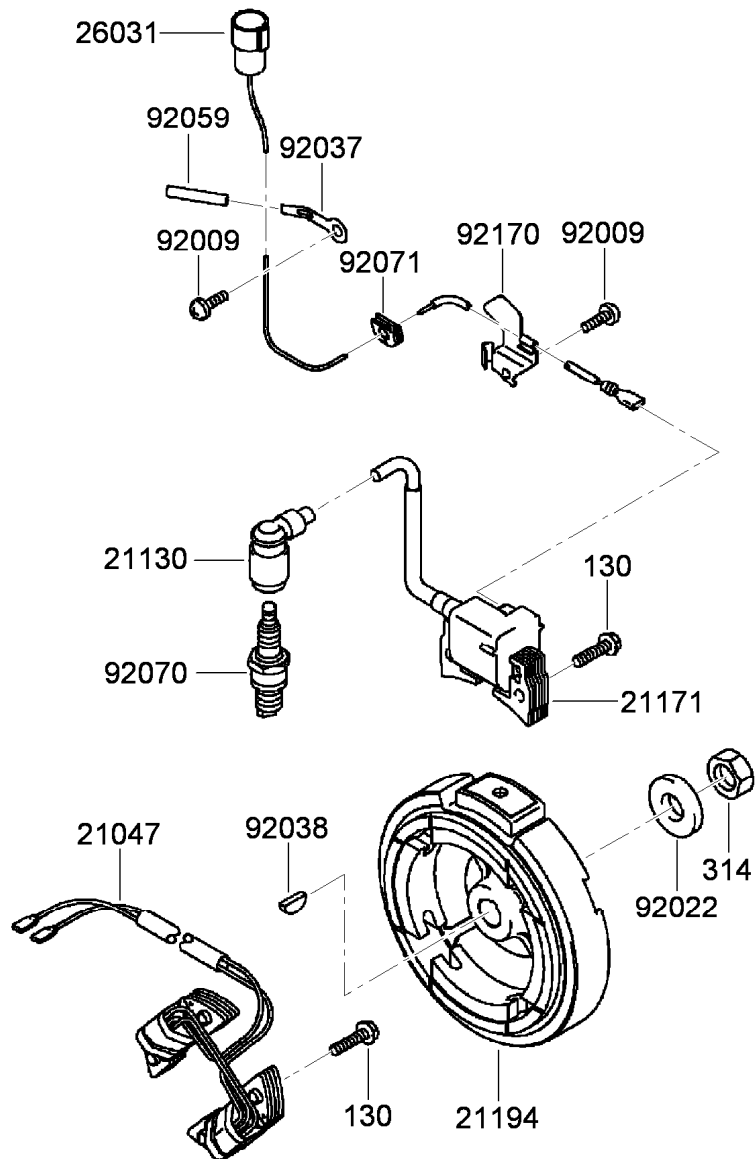

## Electric Equipment Assembly

<i>Ref.</i>	<i>Part Number</i>	<i>Qty.</i>	<i>Description</i>
130	100-2610	6	Bolt-Flanged (6X25)
314	115-1845	1	Nut-Hex, Fine
21047	99-4267	1	Coil-Lighting
21130	KW10087	1	Cap-Sparkplug
21171	94-9031	1	Ignition Coil ASM
21194	99-6237	1	Flywheel ASM
26031	115-1767	1	Harness
92009	95-9716	2	Screw
92022	93-8569	1	Washer
92037	93-8576	1	Clamp
92038	93-8571	1	Key
92059	115-1768	1	Tube (5X6X75)
92070	108-2557	1	Sparkplug (Bpr5Es) (Ngk) Solid
92071	115-1772	1	Grommet
92170	93-8583	1	Clamp



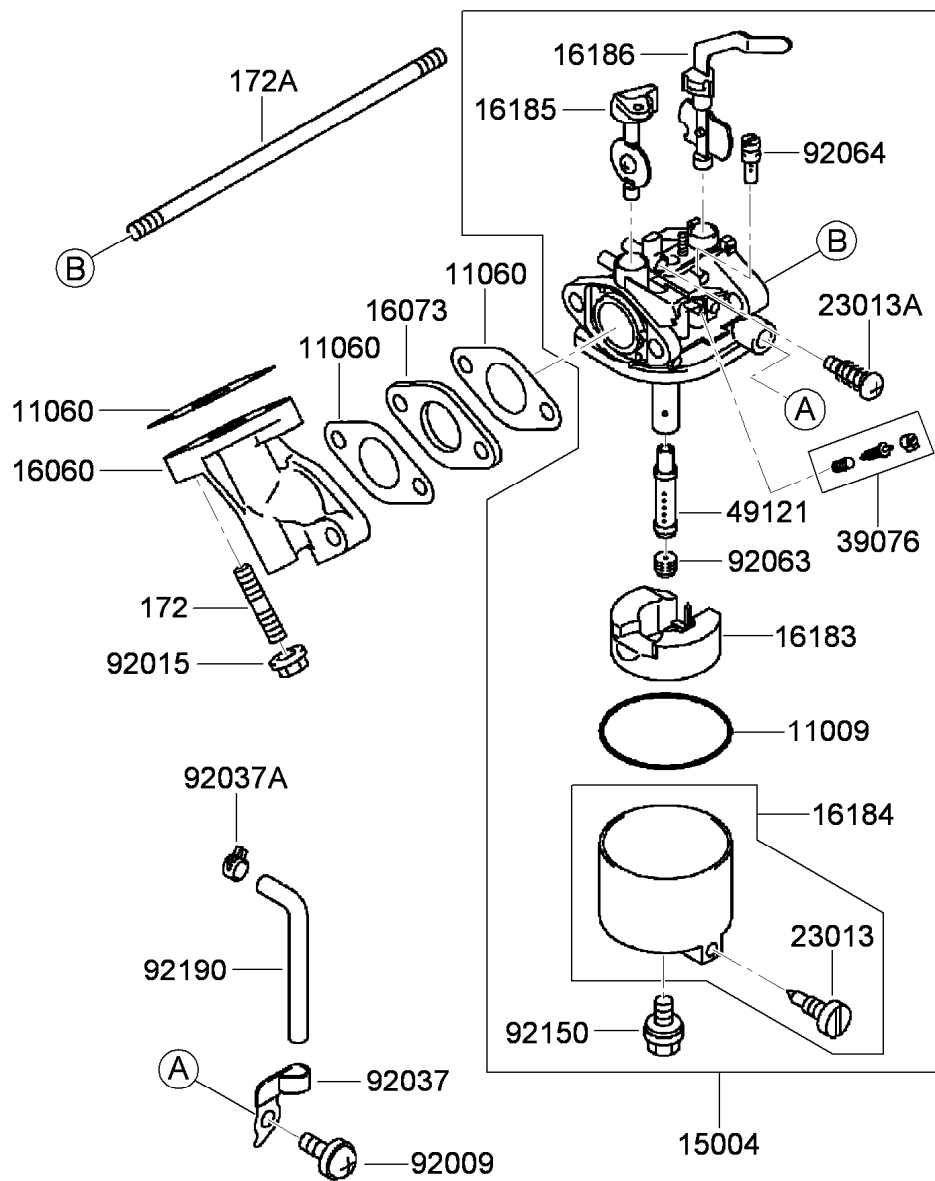

## Carburetor Assembly

Ref.	Part Number	Qty.	Description
172	93-8632	2	Bolt-Stud (6X18)
172A	115-1814	1	Bolt-Stud (6X73)
11009	93-8624	1	Gasket
11060	93-8613	3	Gasket
15004	115-1869	1	Carburetor ASM
16060	93-8633	1	Pipe-Intake
16073	94-9048	1	Insulator
16183	94-6844	1	Float ASM
16184	93-8625	1	Float Chamber ASM
16185	94-9033	1	Throttle Valve ASM
16186	115-1870	1	Choke Valve ASM
23013	93-8626	1	Screw ASM

Ref.	Part Number	Qty.	Description
23013A	93-8619	1	Screw ASM
39076	94-9034	1	Limiter
49121	115-1871	1	Nozzle-Main
92009	94-6845	1	Screw
92015	93-8631	2	Nut
92037	94-6846	1	Clamp
92037A	93-8629	1	Clamp
92063	94-9036	1	Jet-Main (No.65)
92064	94-9037	1	Jet-Pilot (No.40)
92150	93-8627	1	Bolt
92190	93-8630	1	Tube

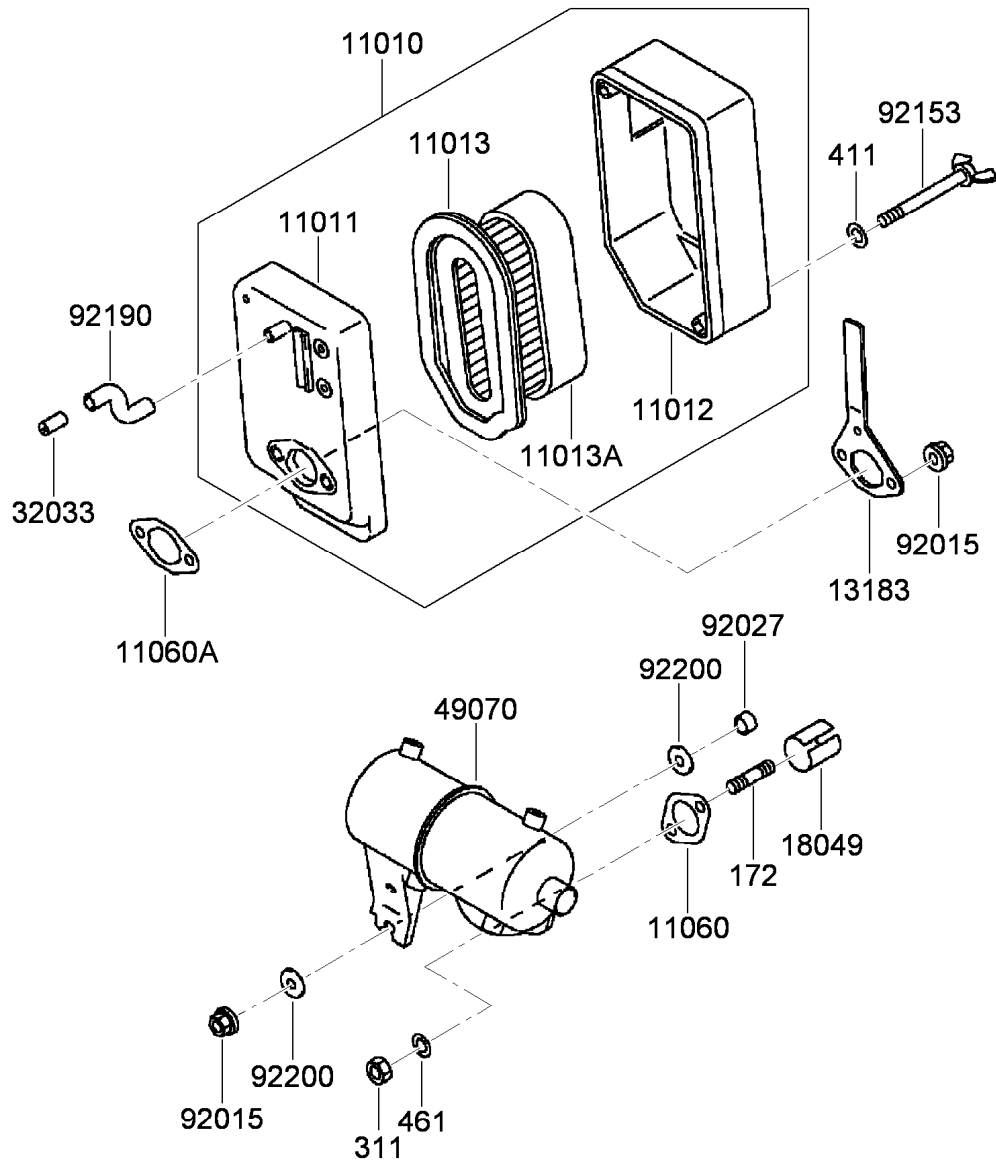

## Air Filter and Muffler Assembly

Ref.	Part Number	Qty.	Description
172	115-1819	2	Bolt-Stud (6X16)
311	93-8656	2	Nut-Hex (6Mm)
411	115-1802	2	Washer-Plain
461	115-1801	2	Washer-Spring
11010	115-1872	1	Air Filter ASM
11011	115-1873	1	Case-Filter, Air
11012	93-8638	1	Cap-Filter, Air
11013	93-8636	1	Element-Filter, Air
11013A	93-8637	1	Element-Filter, Air
11060	93-8654	1	Gasket-Muffler

Ref.	Part Number	Qty.	Description
11060A	93-8657	1	Gasket-Filter, Air
13183	93-8642	1	Plate-Filter, Air
18049	93-8652	1	Pipe-Exhaust
32033	93-8658	1	Pipe
49070	115-1874	1	Muffler
92015	93-8631	3	Nut
92027	93-8651	1	Collar
92153	93-8640	2	Bolt
92190	93-8659	1	Tube
92200	93-8650	2	Washer (.5X18X2.0)

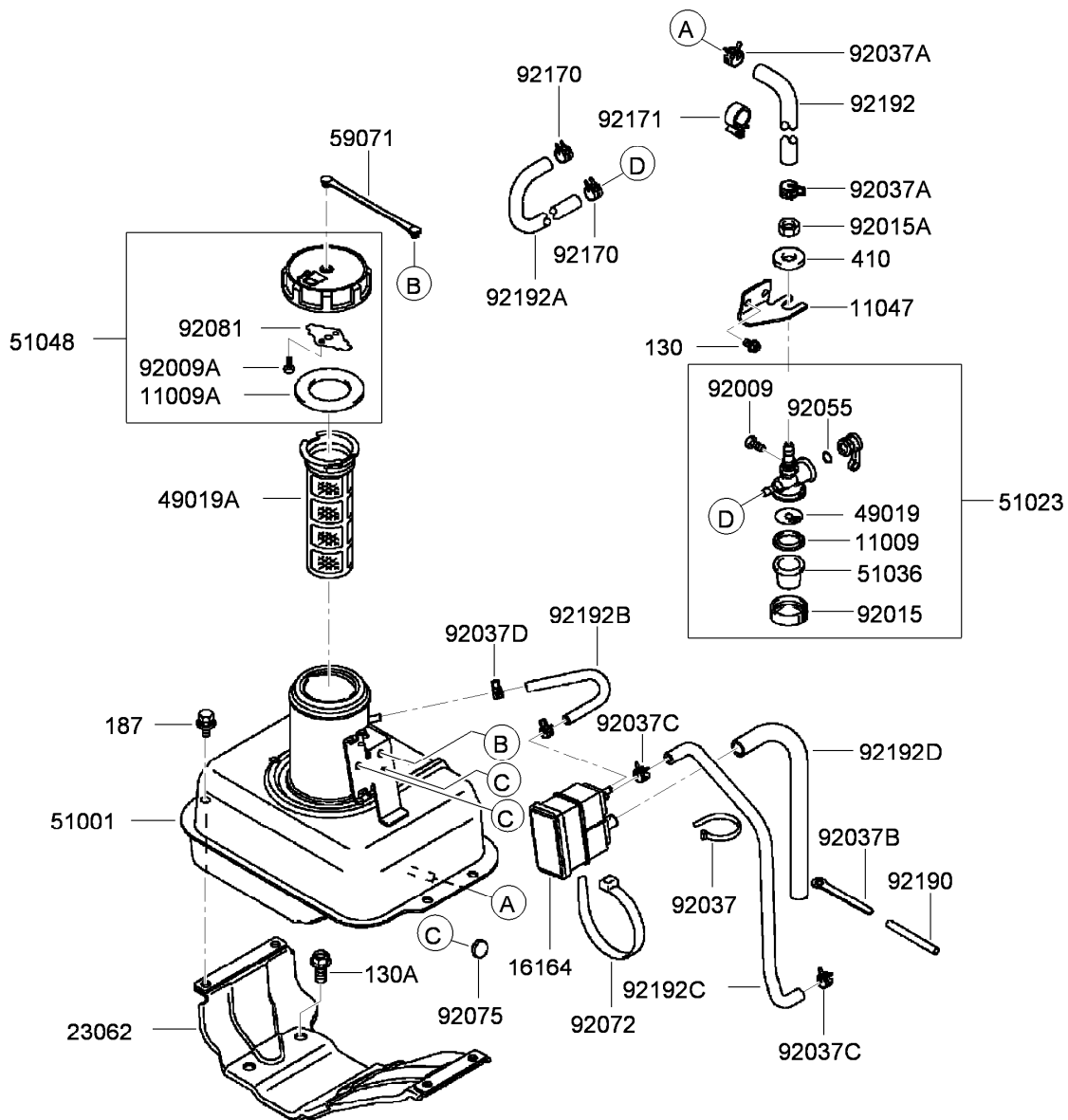

## Fuel Tank and Fuel Valve Assembly

Ref.	Part Number	Qty.	Description
130	115-1864	2	Bolt-Flanged (5X8)
130A	115-1867	4	Bolt-Flanged (8X18)
187	115-1760	4	Bolt-Upset, Wsp (6X16)
410	115-1885	1	Washer-Plain, Small
11009	93-8673	1	Gasket
11009A	93-8662	1	Gasket
11047	93-8681	1	Bracket
16164	115-1859	1	Canister
23062	104-2383	1	Bracket-Tank
49019	94-6849	1	Filter-Tapper, Fuel
49019A	94-6826	1	Filter-Fuel
51001	119-4133	1	Fuel Tank ASM, Carb
51023	93-8669	1	Fuel Tapper ASM
51036	93-8674	1	Cup-Tapper, Fuel
51048	115-1857	1	Tank Cap ASM
59071	115-1856	1	Joint
92009	93-8670	1	Screw
92009A	93-8661	2	Screw
92015	93-8675	1	Nut

Ref.	Part Number	Qty.	Description
92015A	94-9042	1	Nut
92037	115-1855	1	Clamp
92037A	115-1861	2	Clamp-Clip, Hose
92037B	115-1854	1	Clamp
92037C	93-8664	2	Clamp
92037D	93-8676	2	Clamp
92055	93-8671	1	O-Ring
92072	115-1853	1	Band
92075	115-1852	2	Damper
92081	93-8663	1	Spring
92170	115-1865	2	Clamp
92171	115-1862	1	Clamp
92190	115-1851	1	Tube
92192	115-1863	1	Tube (6.2X13.2X200)
92192A	115-1866	1	Tube (4X11X160)
92192B	115-1889	1	Tube
92192C	115-1890	1	Tube
92192D	115-1891	1	Tube

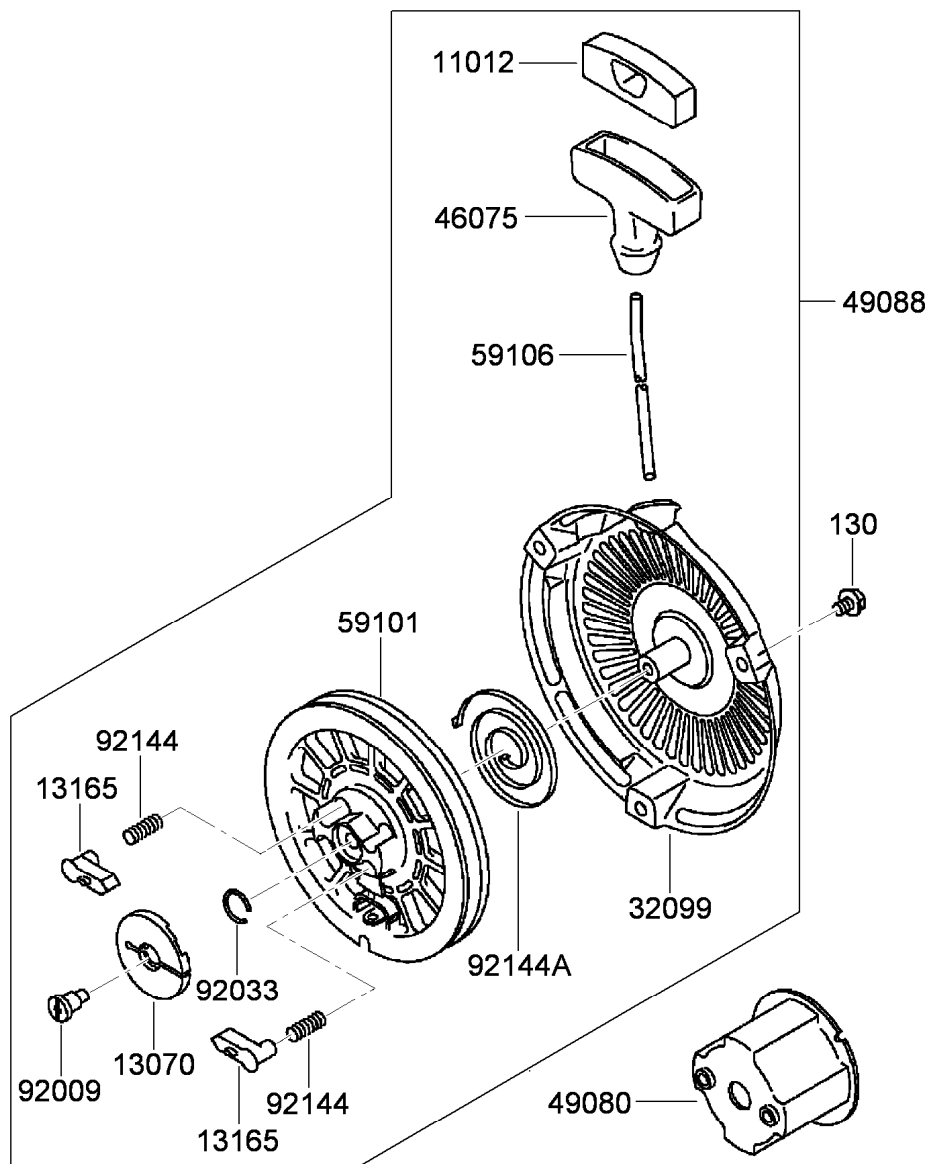

## Starter Assembly

Ref.	Part Number	Qty.	Description
130	115-1765	3	Bolt-Flanged (6X8)
11012	94-9044	1	Cap-Grip
13070	93-8562	1	Guide-Pawl
13165	93-8554	2	Pawl-Starter, Recoil
32099	94-9046	1	Case-Starter, Recoil
46075	94-9045	1	Grip-Starter, Recoil
49080	93-8567	1	Pulley-Recoil
49088	93-8552	1	Recoil Starter ASM
59101	93-8556	1	Reel-Starter, Recoil
59106	93-8560	1	Rope (4X1500)
92009	93-8553	1	Screw
92033	93-8561	1	Ring-Retaining
92144	93-8555	2	Spring-Return
92144A	93-8557	1	Spring

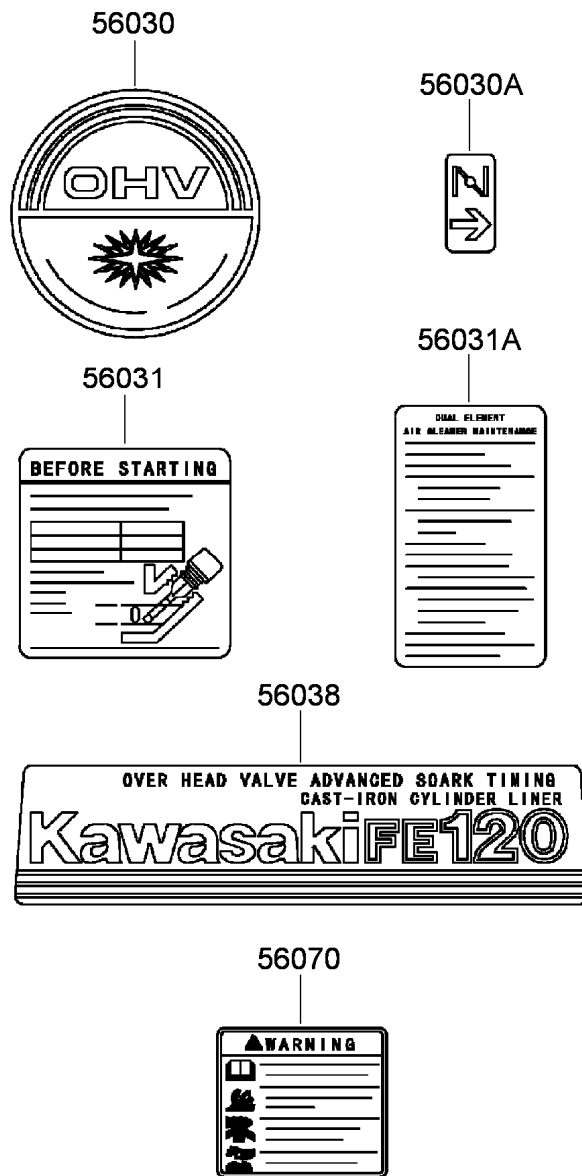

## Label Set

<i>Ref.</i>	<i>Part Number</i>	<i>Qty.</i>	<i>Description</i>
56030	94-9027	1	Label-Recoil
56030A	93-8687	1	Decal-Choke
56031	93-8689	1	Decal-Instructions
56031A	93-8690	1	Decal-Maintenance
56038	94-9028	1	Label-Kawasaki
56070	93-8692	1	Decal-Warning

# Attachments and Accessories

## For 04034 Greensmaster 1000 Mower

<b>Product Name</b>	<b>Model/Part</b>
Light Kit.....	04061
Dethatcher Kit.....	04109
Dethatcher Kit.....	04111
Out Front Brush Kit.....	04119
Wheel Kit.....	04123
Groomer Reel Kit.....	04131
Full Roller ASM (21 inch).....	104-2642
Hour Meter Kit.....	105-5350
Roller Rebuild Kit.....	107-1588
Bedbar-Aggressive.....	112-9279-03
Operator Presence Kit.....	112-9282
Smooth Scraper Kit.....	112-9285
Scraper Brush Kit.....	112-9286
Comb Scraper Kit.....	112-9287
Wide Wiehle Scraper Kit.....	112-9288
Narrow Wiehle Scraper Kit.....	112-9289
Bedknife-Edgemax, Microcut.....	115-1880
Bedknife-Edgemax, Tournament Cut.....	115-1881
16-Tooth Traction Pulley Kit.....	115-1886
Spark Arrestor Kit.....	117-1441
14 Blade Reel ASM.....	117-1449
MVP Filter and Spark Plug Kit.....	30065
Swaged Roller ASM.....	52-3590
Auxiliary Roller Kit.....	65-8560
.25 inch Clip Kit.....	65-9000
Wiehle Roller ASM (Cast Iron).....	71-1550
Wiehle Roller ASM (.43 inch Spacing).....	88-6790
Bedknife-Microcut.....	93-4262
Bedknife-Low Cut.....	93-4264
8 Blade Reel ASM.....	93-6087
Wiehle Roller ASM (2.5 inch Dia).....	93-9045
Height-of-Cut Bar ASM.....	94-9010
Jet-Main, No. 62 (High Altitude).....	98-8735
Jet-Main, No. 60 (High Altitude).....	98-8736



**Count on it.**