



Count on it.

Parts Catalog

53cm Super Bagger Lawn Mower

Model No. 20897—Serial No. 311000001 and Up

Ordering Replacement Parts

To order replacement parts, please supply the part number, the quantity, and the description of each part desired.

Understanding Reference Numbers

Each identified part in an illustration has a reference number. The reference number for a part also appears in the parts list, along with other information about the part.

This catalog uses two special reference number formats, one to indicate parts in a service assembly and another to indicate the quantity of a given part in an illustration.

Service Assembly Reference Numbers

Parts in service assemblies have reference numbers in the form a:b. The a represents the reference number of the entire service assembly and the b represents a sequential number unique to each part within the service assembly.

For example, a wheel assembly might be identified by reference number 6, the tire by 6:1, the valve by 6:2, and the wheel by 6:3. When you order the assembly identified by reference number 6, you receive all parts identified by reference numbers 6:1, 6:2, and 6:3. However, you may also order any part individually. Reference numbers of this type appear in illustration and in parts lists.

Reference Numbers Indicating Quantity

In an illustration, if a reference number indicates more than one part, the reference number has the form nX y. The n represents the quantity of the part, the X is the multiplication symbol, and the y represents the reference number.

For example, in an illustration, the reference number 2X 37 means that two of the parts identified by reference number 37 are indicated.

List of Abbreviations

AR: as required	HOC: height-of-cut	RRB: rear roller brush
ASM: assembly	HSBH: hex socket button head	SFH: slotted fillister head
BBC: blade brake control	HSFH: hex socket flat head	SHH: slotted hex head
BHTF: button head thread forming	HSH: hex socket head	SHWH: slotted hex washer head
CARR: carriage	HWH: hex washer head	SPH: slotted pan head
CCW: counter clockwise	HWTF: hex washer head thread forming	SQH: square head
CW: clockwise	HYD: hydraulic	SRH: slotted round head
DEG: degrees	LH: left hand	STD: standard
DPA: Dual Point Adjustment	LP: Liquid Propane	TAP: self tapping
ECM: electronic control module	NI: nylon insert	TTH: torx truss head
EXT: external	NPTF: national pipe thread fine	
FH: flat head	PFH: phillips flat head	
GA: gauge	PPH: phillips pan head	
HD: heavy-duty	PPHTF: phillips pan head thread forming	
HF: hex flange	PRH: phillips round head	
HH: hex head	PTH: phillips truss head	
HHF: hex head flange	PTO: power-take-off	
HHFTF: hex head flange thread forming	RH: right hand	
HJ: hex jam	ROPS: roll-over protection system	
HLH: hex lag head		

Contents

Housing and Tunnel Assembly.....	4
Side Discharge, Transmission and Rear Wheel Assembly	5
Upper Handle Assembly	6
Lower Handle Assembly	7
Engine and Blade Assembly	8
Blade Brake Control Assembly.....	9
Switch Assembly	10
Rear Bag Assembly	11
Attachments and Accessories	12

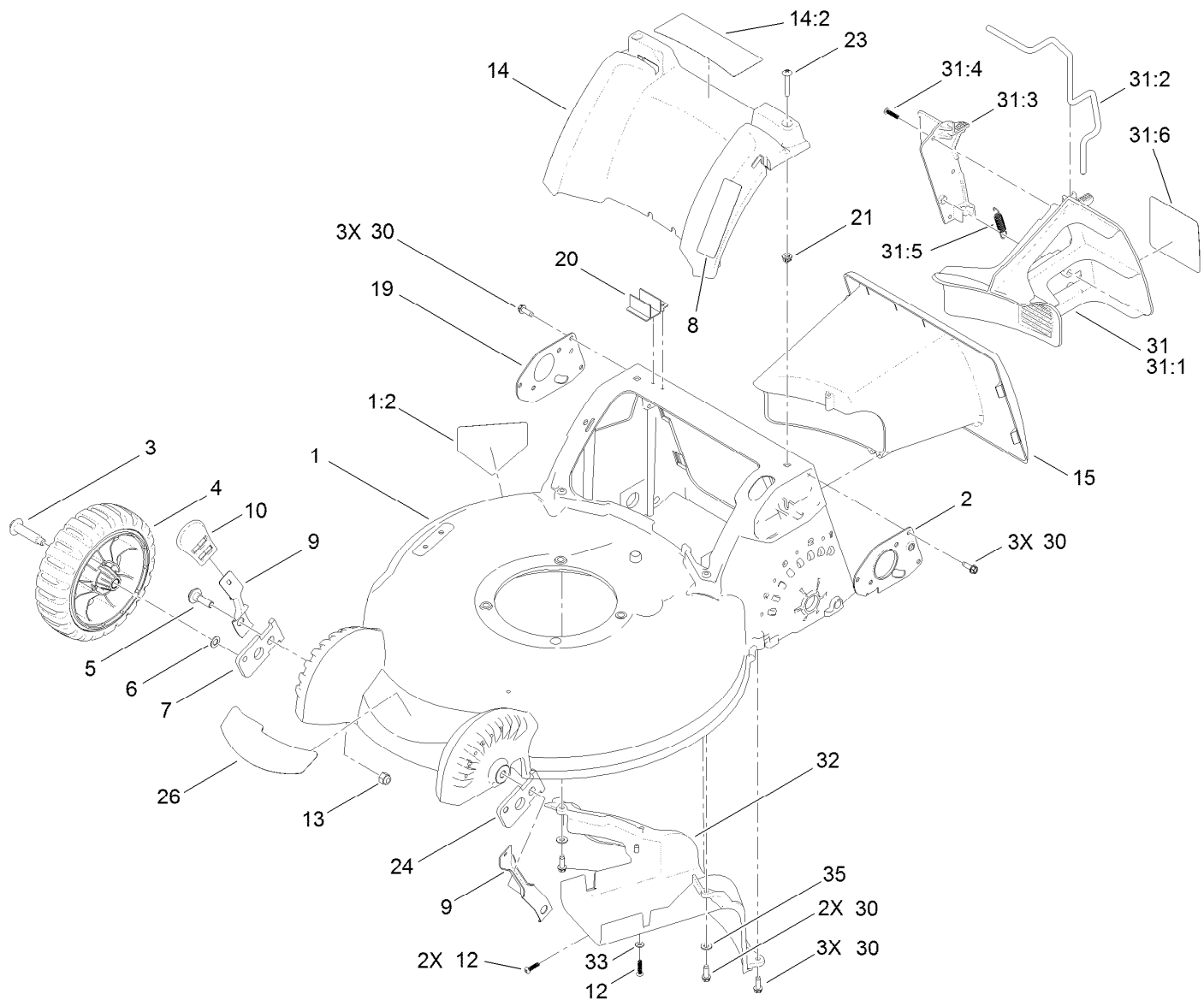

Housing and Tunnel Assembly

Ref.	Part Number	Qty.	Description	Ref.	Part Number	Qty.	Description
1	119-3781	1	Housing ASM	20	117-5905	1	Module-Switch
1:2	112-8760	1	Decal-Danger	21	94-1610	2	Nut-Clip
2	110-9415-03	1	Mount-Handle, LH	23	108-0965	2	Screw-PTH
3	614650	2	Bolt-Shoulder	24	110-9420	1	Arm-Pivot, LH
4	117-4103	2	8 Inch Wheel ASM	26	120-5233	1	Decal-Deck
5	614672	2	Bolt-Shoulder	30	49-2040	11	Screw-HWHTF
6	40-1940	2	Washer	31	110-9468	1	Mulch Plug ASM
7	110-9421	1	Arm-Pivot, RH	31:1	110-9446	1	Plug-Mulch, LH
8	117-5902	1	Decal-Quick Stow	31:2	110-9448	1	Latch-Plug, Mulch
9	110-9434	2	Arm-Spring, Front	31:3	110-9447	1	Plug-Mulch, RH
10	110-0549	2	Knob-HOC	31:4	108-7476	3	Screw-Plastite
12	108-7476	6	Screw-Plastite	31:5	110-9458	1	Spring-Extension
13	3296-39	2	Nut-Lock, NI	31:6	110-9457	1	Decal-Plug, Mulch
14	115-3177	1	Cover-Rear	32	110-9423	1	Baffle-Rear
14:2	114-2820	1	Decal-Warning	33	3256-14	1	Washer-Flat
15	110-9455	1	Tunnel	35	3256-22	2	Washer-Flat
19	110-9416-03	1	Mount-Handle, RH				

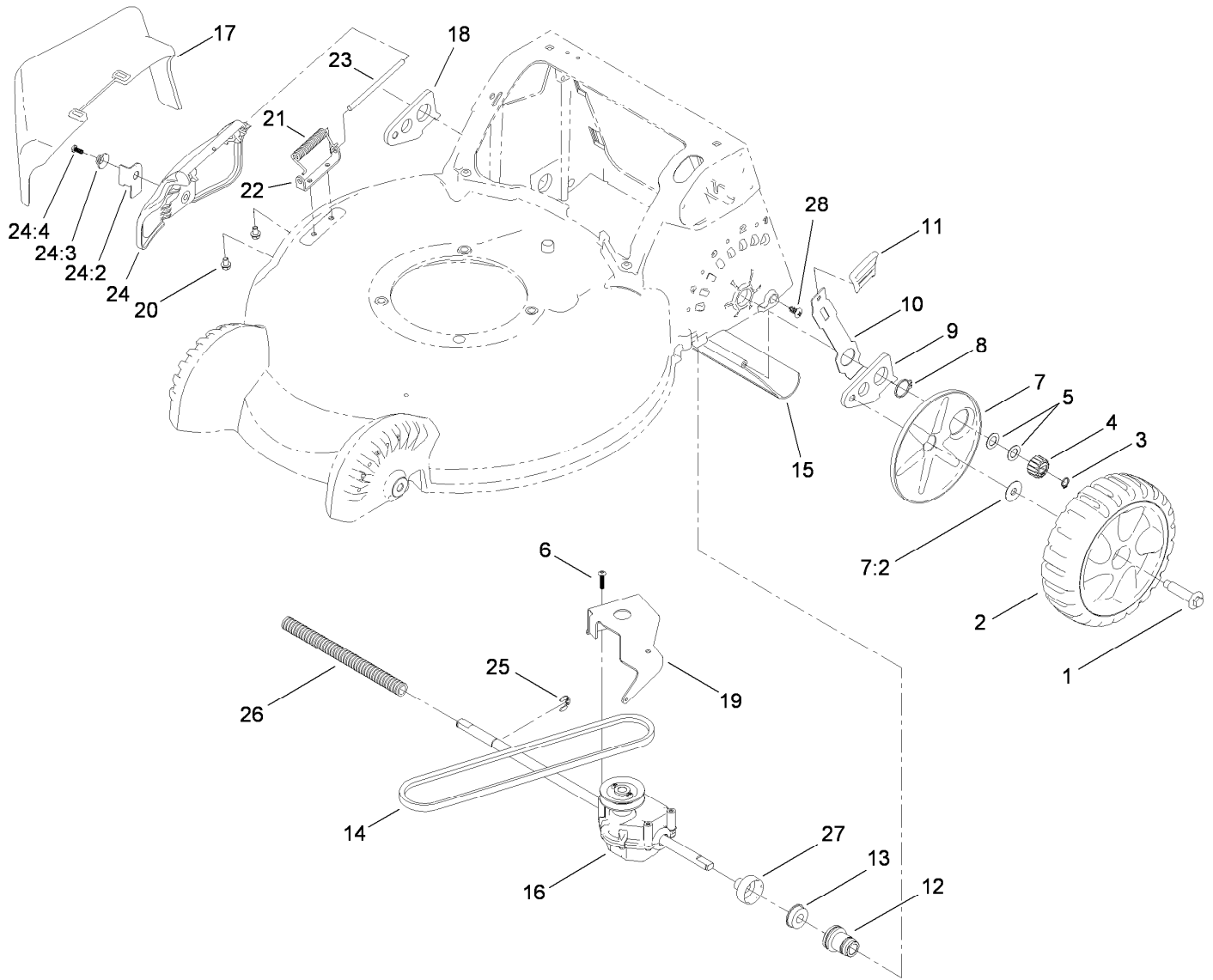

Side Discharge, Transmission and Rear Wheel Assembly

Ref.	Part Number	Qty.	Description	Ref.	Part Number	Qty.	Description
1	614650	2	Bolt-Shoulder	16	114-2812	1	Transmission ASM
2	117-4104	2	Rear Wheel ASM	17	105-3028	1	Chute-Discharge, Side
3	32151-61	2	Ring-Retaining	18	108-9343	1	Arm-Rear Pivot, RH
4	110-9417	2	Gear-Pinion, 15T	19	114-7977-03	1	Bracket-Transmission
5	36-4780	2	Washer-Plain	20	99-8445	2	Screw-HWH
6	120-0185	3	Screw-Pan Head, T20	21	99-5293	1	Spring-Torsion
7	117-4197	2	Wheel Cover ASM	22	112-6416	1	Bracket-Cover
7:2	614426	1	Washer-Stepped	23	99-5291	1	Rod-Cover
8	32151-36	2	Ring-Retaining	24	106-8376	1	Discharge Door ASM
9	108-9344	1	Arm-Rear Pivot, LH	24:2	107-0795	1	Latch-Door
10	110-9445	2	Arm-Spring, Rear	24:3	107-7456	1	Cap-Door
11	110-0549	2	Knob-HOC	24:4	107-7461	1	Screw-Plastite
12	110-9422	2	Retainer-Bearing	25	65-2720	1	Ring-Clip, Locking
13	104-8699	2	Bearing-Ball	26	24-7922	1	Conduit-Convolute, Split
14	110-9429	1	V-Belt	27	114-2755	2	Cap-Bearing
15	112-8768	1	Shield-Trailing	28	117-1092	2	Screw-PTH

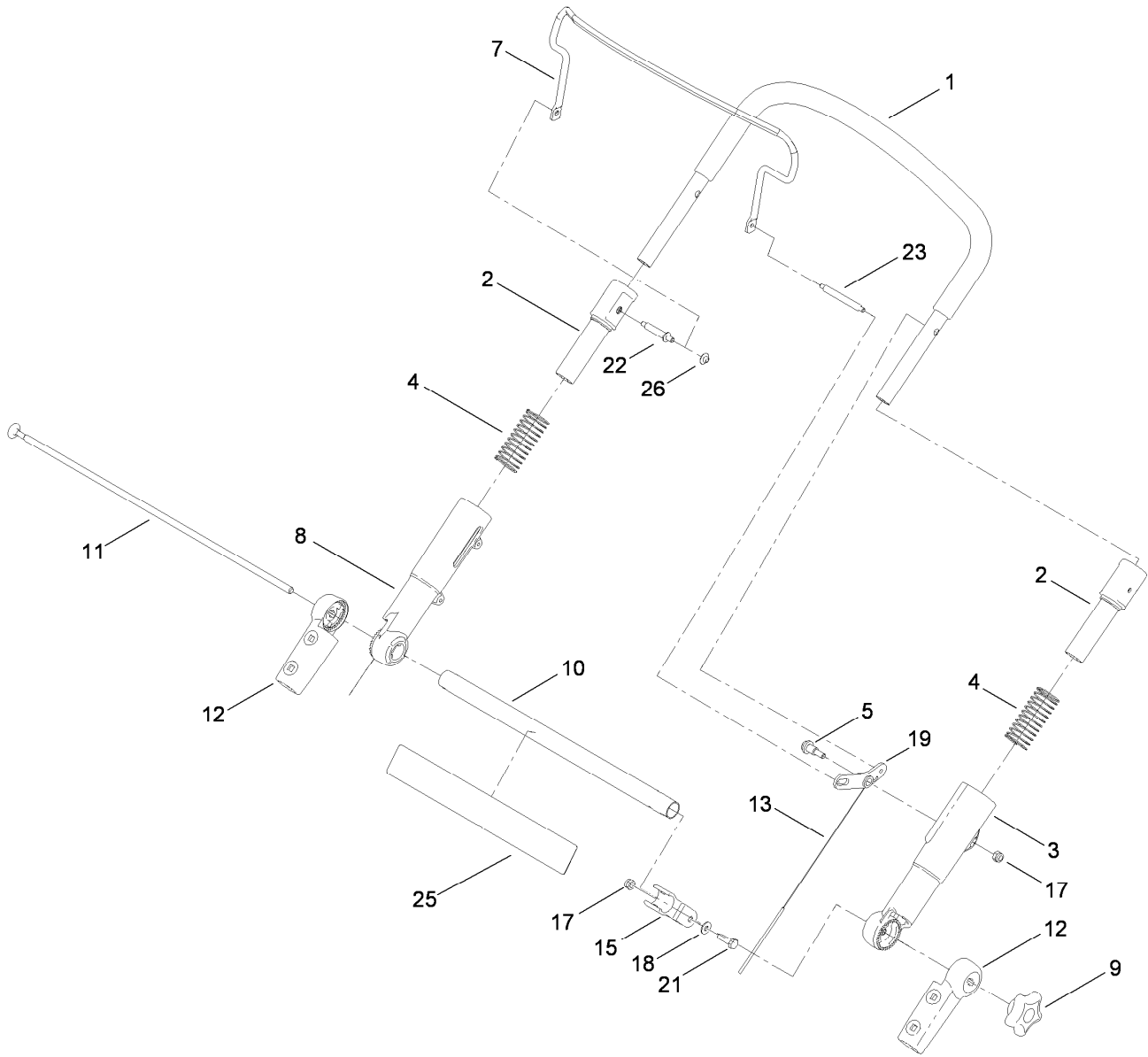

Upper Handle Assembly

Ref.	Part Number	Qty.	Description	Ref.	Part Number	Qty.	Description
1	108-0974	1	Upper Handle ASM	13	110-9465	1	Cable-Traction
2	112-8754	2	Sleeve-Inner	15	112-8801	1	Clamp-Cable
3	112-1544	1	Sleeve-Outer, LH	17	3296-73	2	Nut-Lock, NI
4	107-3869	2	Spring-Compression	18	3256-1	1	Washer-Flat
5	104-0858	1	Bolt-Shoulder	19	107-3893	1	Lever-Traction
7	110-1819-03	1	Bail-Brake	21	321-5	1	Screw-HH
8	112-1545	1	Sleeve-Outer, RH	22	108-0959	1	Pin-Handle
9	117-5976	1	Knob-Handle, Locking	23	110-1753	1	Pin-Handle, BBC
10	107-3867-03	1	Tube-Cross	25	120-3907	1	Decal-Ads
11	107-3871	1	Rod-Threaded	26	108-9378	1	Retainer-Push On
12	107-3865	2	Mount-Handle, Lower				

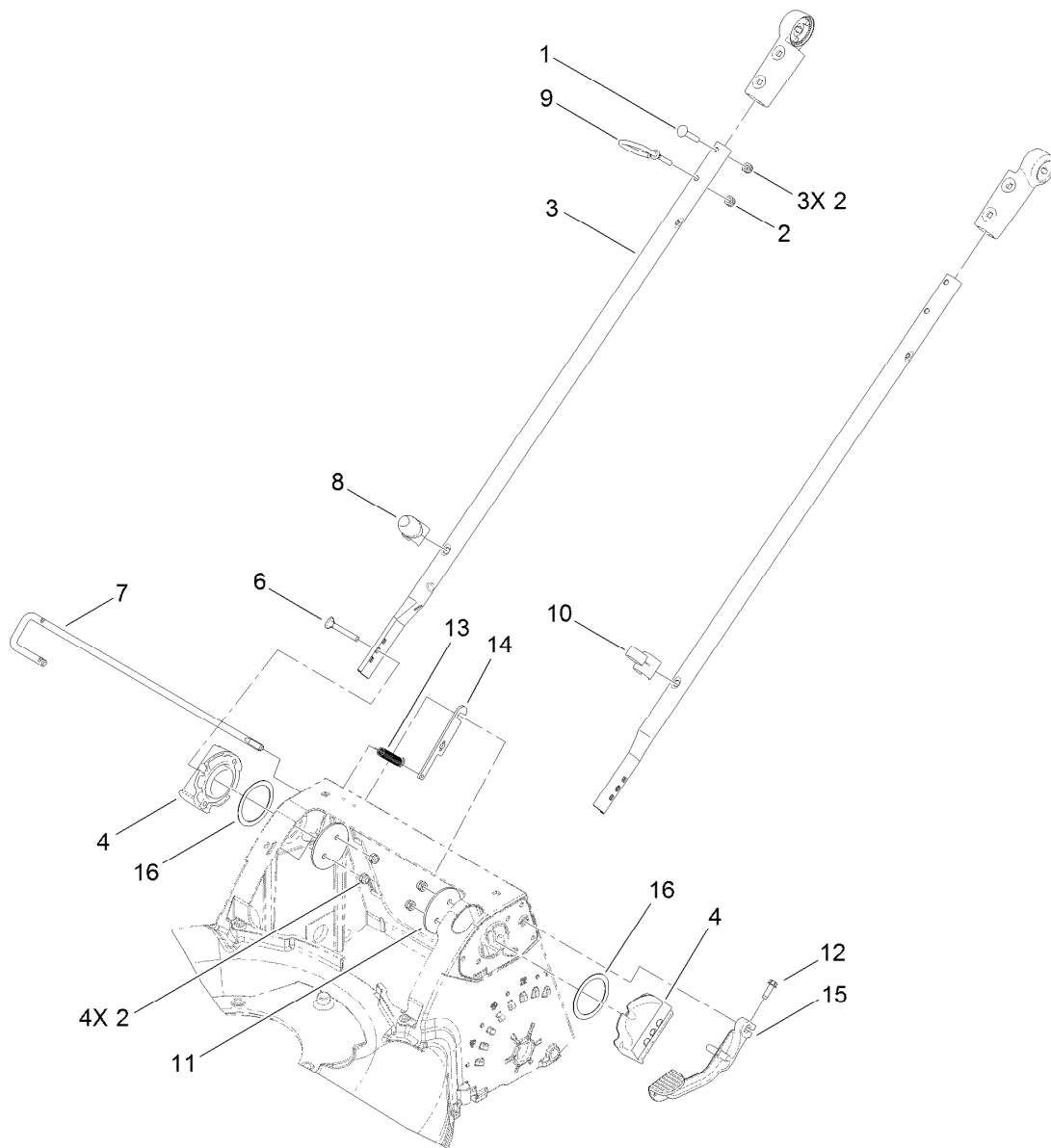

Lower Handle Assembly

Ref.	Part Number	Qty.	Description
1	108-0988	3	Screw-CARR
2	3296-73	8	Nut-Lock, NI
3	107-3887-03	2	Tube-Lower
4	119-3847-03	2	Mount-Handle
6	95-4453	4	Screw
7	112-8755	1	Rod-Release, Handle
8	117-4141	1	Guide-Rope, Lower
9	107-3908	1	Guide-Rope, Upper
10	114-7988	1	Guide-Cable
11	107-3944-03	2	Plate
12	49-2040	1	Screw-HWHTF
13	112-1542	1	Spring-Extension
14	112-1539	1	Plate-Rod, Release
15	110-1823-03	1	Lever-Release
16	107-3947	2	Washer-Nylon

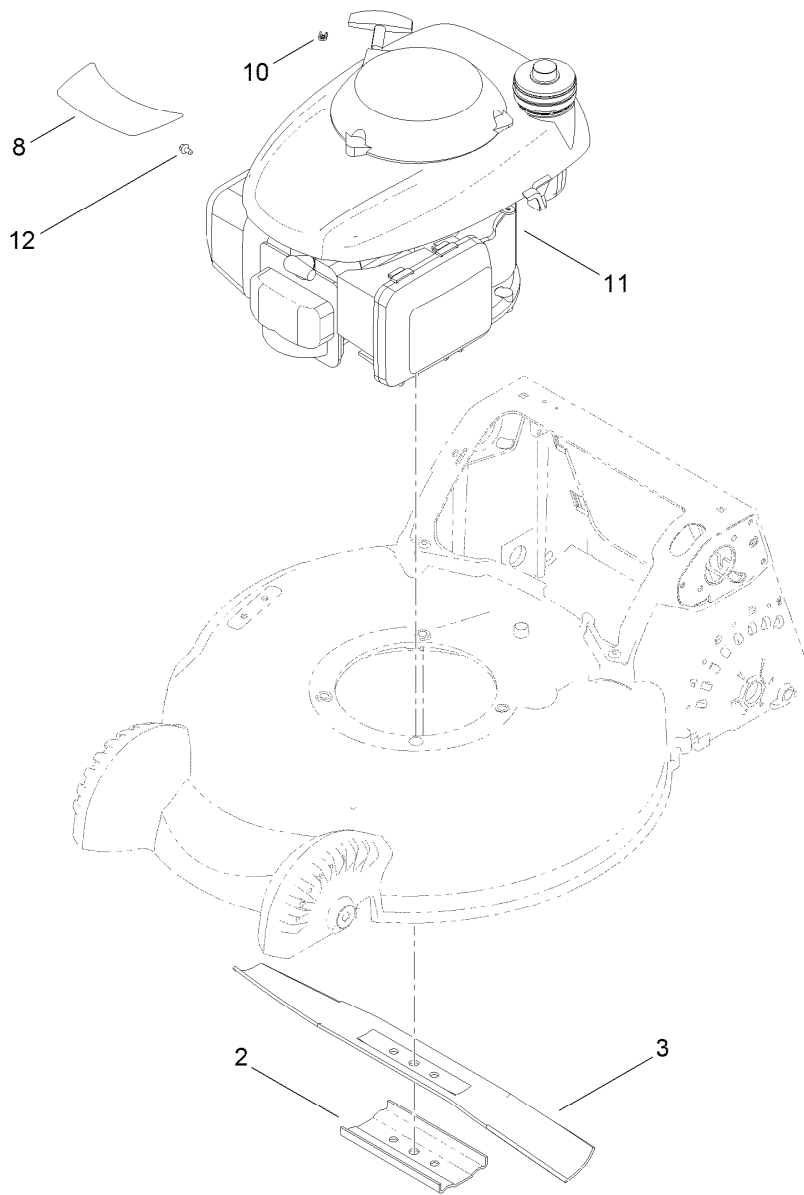

Engine and Blade Assembly

<i>Ref.</i>	<i>Part Number</i>	<i>Qty.</i>	<i>Description</i>
2	108-3766-03	1	Support-Blade
3	108-0954-03	1	Blade-21 Inch
8	120-1949	1	Decal-Engine
10	92-1701	1	Stop-Rope
11		1	Engine-Honda, Gcv160A0 S3Te ● ■
12	98-1394	1	Screw-HWH

● Not serviced separately

■ Obtain parts from www.honda-engines.com

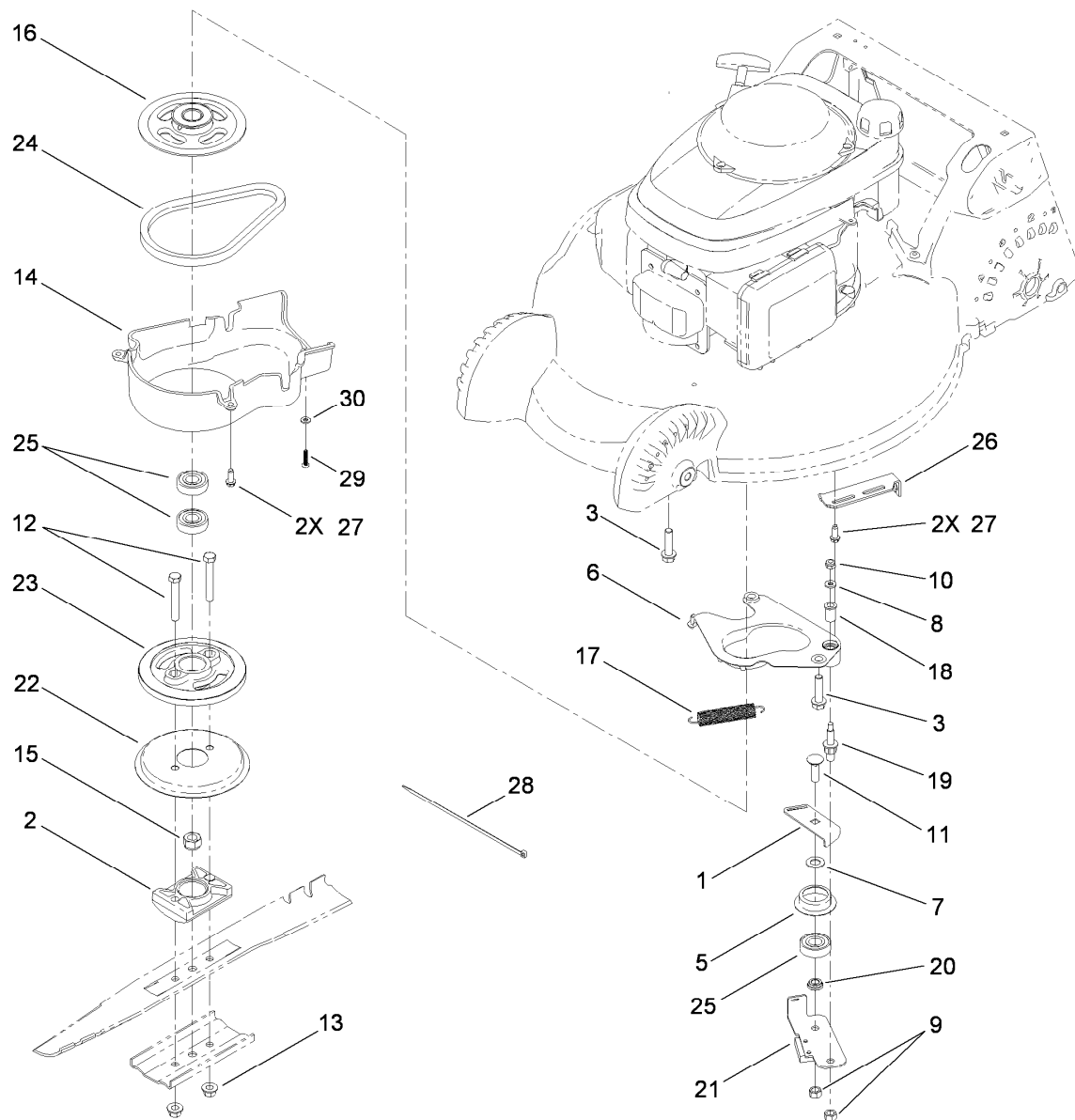

Blade Brake Control Assembly

Ref.	Part Number	Qty.	Description
1	107-7471	1	Plate-Guide
2	107-7487	1	Support-Blade
3	32144-102	3	Screw-HWH
5	108-3790	1	Retainer-Belt
6	107-0761	1	Plate-Anchor
7	605256	1	Washer-Plain
8	3256-16	1	Washer-Flat
9	603773	2	Nut
10	3296-73	1	Nut-Lock, NI
11	3231-25	1	Screw-CARR
12	3211-42	2	Screw-HH
13	54-9190	2	Nut-Lock
14	107-7488	1	Cover
15	108-9342	1	Nut-Hex
16	117-5970	1	Pulley-BBC

Ref.	Part Number	Qty.	Description
17	108-3792	1	Spring-Tension, Brake
18	107-0797	1	Bushing
19	107-0759	1	Bolt-Shoulder
20	107-0758	1	Spacer-Bearing
21	120-3327	1	Brake Arm ASM
22	108-3787	1	Disc
23	107-0754	1	Drum
24	110-1790	1	Belt-BBC
25	100-1048	3	Bearing-Ball
26	110-9425-03	1	Bracket-Cable
27	49-2040	4	Screw-HWHTF
28	614249	1	Strap-Tie
29	108-7476	1	Screw-Plastite
30	3256-14	1	Washer-Flat

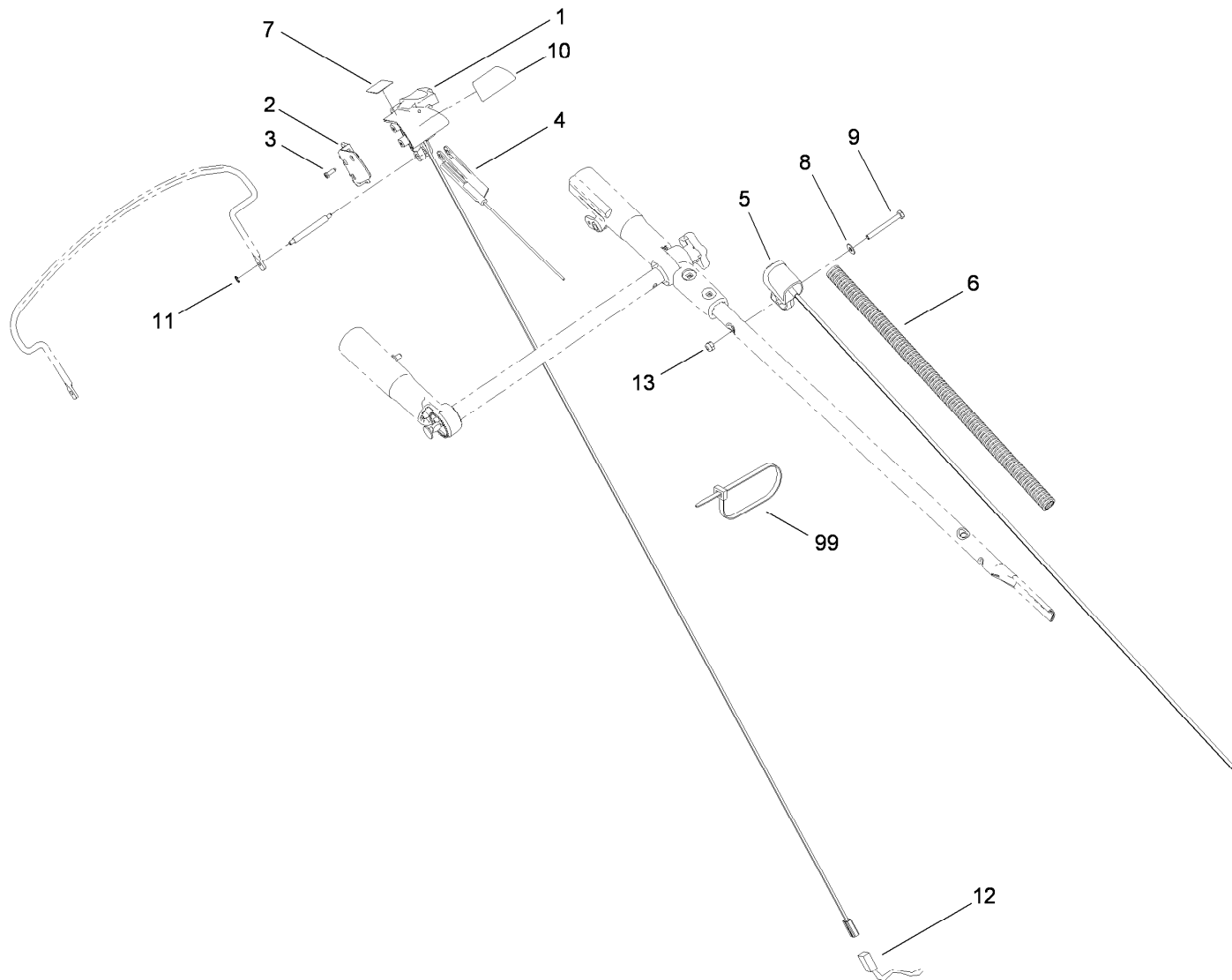

Switch Assembly

<i>Ref.</i>	<i>Part Number</i>	<i>Qty.</i>	<i>Description</i>
1	117-5908	1	Safety Switch ASM
2	108-7532	1	Cover-Switch
3	32144-111	3	Screw-PPH
4	112-1536	1	Cable-Bcs
5	117-5975	1	Switch Housing ASM
6	119-3778	1	Tube-Loom, Split
7	119-3796	1	Decal-Control, Blade
8	3256-1	1	Washer-Flat
9	321-13	1	Screw-HH
10	119-3821	1	Decal-Brake Control, Blade
11	110-1758	1	Ring-Retaining
12	119-0288	1	Harness-Wire
13	3296-73	1	Nut-Lock, NI
99	614249	2	Strap-Tie

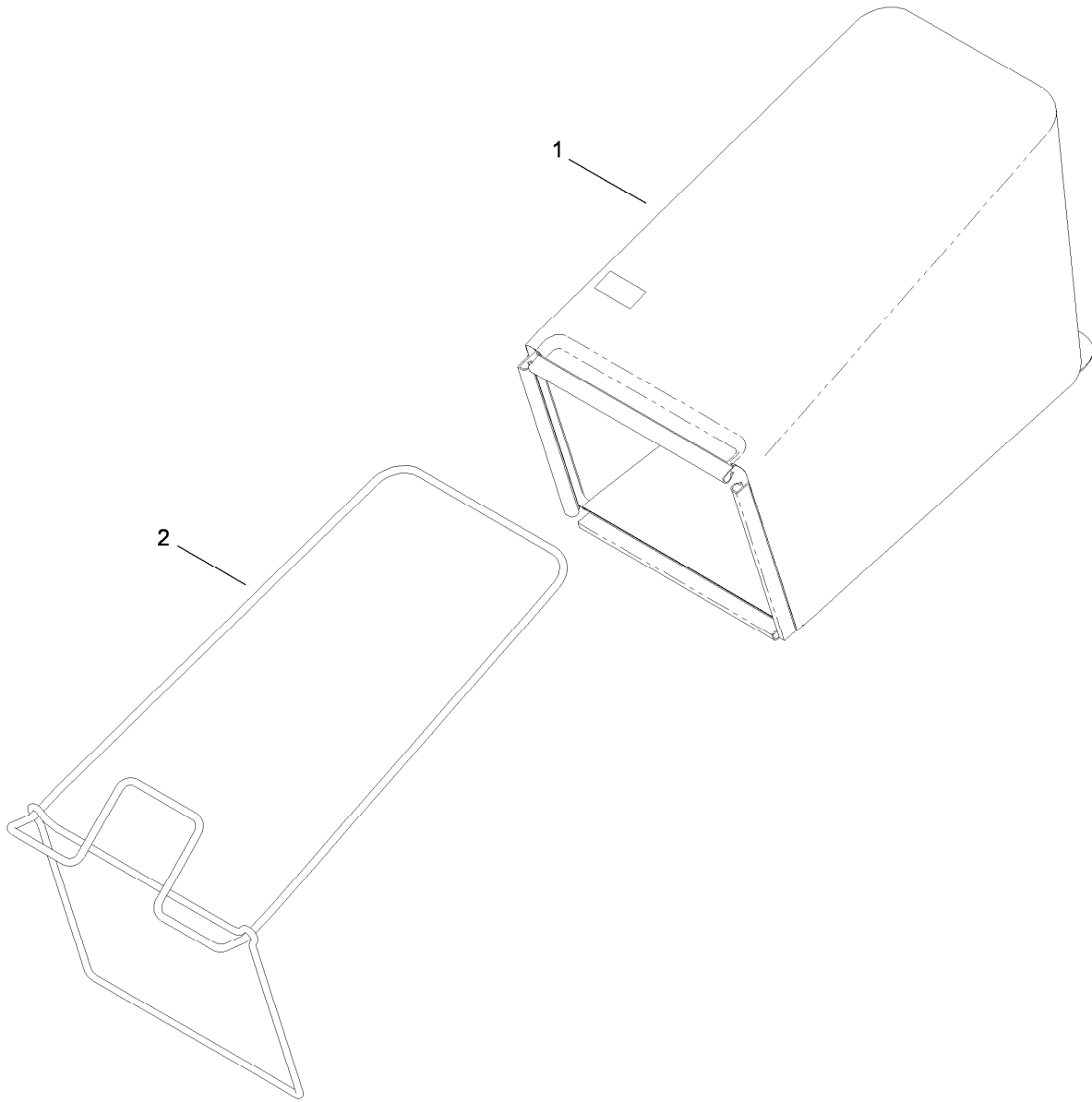

Rear Bag Assembly

<i>Ref.</i>	<i>Part Number</i>	<i>Qty.</i>	<i>Description</i>
1	117-4191	1	Grass Bag ASM
2	112-8750-03	1	Frame-Bag

Attachments and Accessories

For 20897 53cm Super Bagger Lawn Mower

Product Name

Model/Part

Cruise Control Kit..... 89919

Notes:

Notes:

Notes:



Count on it.