



Count on it.

Operator's Manual

66 Inch Rake-O-Vac® Sweeper

Model No. 07050—Serial No. 311000001 and Up

This product complies with all relevant European directives, for details please see the separate product specific Declaration of Conformity (DOC) sheet.

WARNING

CALIFORNIA Proposition 65 Warning

The engine exhaust from this product contains chemicals known to the State of California to cause cancer, birth defects, or other reproductive harm.

This spark ignition system complies with Canadian ICES-002.

Important: This engine is not equipped with a spark arrester muffler. It is a violation of California Public Resource Code Section 4442 to use or operate the engine on any forest-covered, brush-covered, or grass-covered land. Other states or federal areas may have similar laws.

Introduction

Read this information carefully to learn how to operate and maintain your product properly and to avoid injury and product damage. You are responsible for operating the product properly and safely.

You may contact Toro directly at www.Toro.com for product and accessory information, help finding a dealer, or to register your product.

Whenever you need service, genuine Toro parts, or additional information, contact an Authorized Service Dealer or Toro Customer Service and have the model and serial numbers of your product ready. Figure 1 illustrates the location of the model and serial numbers on the product. Write the numbers in the space provided.

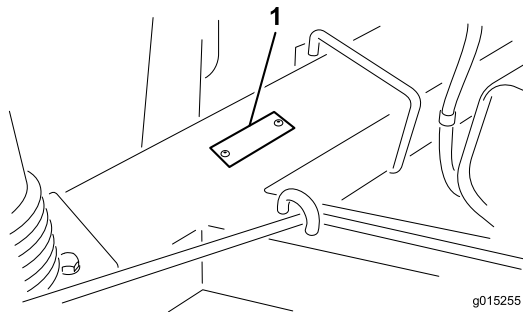

Figure 1

1. Location of the model and serial numbers

Model No. _____

Serial No. _____

This manual identifies potential hazards and has safety messages identified by the safety alert symbol (Figure 2), which signals a hazard that may cause serious injury or death if you do not follow the recommended precautions.



Figure 2

1. Safety alert symbol

This manual uses 2 other words to highlight information. **Important** calls attention to special mechanical information and **Note** emphasizes general information worthy of special attention.

Contents

Cleaning the Blower Housing.....	29
Storage.....	30

Introduction.....	2
Safety.....	4
Safe Operating Practices.....	4
Safety and Instructional Decals.....	6
Setup.....	8
1 Activating and Charging the Battery.....	8
2 Mount the Sweeper to the Prime Mover.....	9
3 Removing Sweeper from the Prime Mover.....	10
Product Overview.....	11
Controls.....	11
Specifications.....	12
Operation.....	12
Adding Fuel.....	12
Checking the Engine Oil Level.....	13
Starting and Stopping the Engine.....	13
Transporting the Machine.....	14
Adjusting the Reel Support Arm.....	14
Adjusting the Rake Depth.....	14
Adjust the Rubber Flap.....	15
Inspect and Cleanup after Operation.....	15
Operating Tips.....	16
Maintenance.....	17
Recommended Maintenance Schedule(s).....	17
Lubrication.....	18
Lubrication.....	18
Oil the Sweeper Jack.....	18
Engine Maintenance.....	19
Servicing the Air Cleaner.....	19
Changing the Engine Oil and Filter.....	19
Servicing the Spark Plugs.....	20
Remove Debris from the Engine.....	20
Fuel System Maintenance.....	21
Replacing the Fuel Filter.....	21
Electrical System Maintenance.....	22
Servicing the Battery.....	22
Drive System Maintenance.....	23
Tire Maintenance.....	23
Belt Maintenance.....	23
Inspecting the Belts.....	23
Adjusting the Belts.....	24
Changing the Rubber Flap.....	25
Pulley Removal.....	26
Flex Tip Reel Removal.....	26
Thatcher Installation.....	27
Flex Tip Rake Rod Or Finger Plate Replacement.....	28
Flex Tip Rake Tine Replacement.....	28
Brush Half Replacement.....	29
Cleaning.....	29

Safety

Improper use or maintenance by the operator or owner can result in injury. To reduce the potential for injury, comply with these safety instructions and always pay attention to the safety alert symbol, which means **Caution, Warning, or Danger**—personal safety instruction. Failure to comply with the instruction may result in personal injury or death.

Safe Operating Practices

Training

- Read the *Operator's Manual* and other training material. If the operator(s) or mechanic(s) can not read English it is the owner's responsibility to explain this material to them.
- Become familiar with the safe operation of the equipment, operator controls, and safety signs.
- All operators and mechanics should be trained. The owner is responsible for training the users.
- Never let children or untrained people operate or service the equipment. Local regulations may restrict the age of the operator.
- The owner/user can prevent and is responsible for accidents or injuries occurring to himself or herself, other people or property.
- The machine must be towed to operate, it is extremely important that the tow tractor be carefully selected to assure the best performance and safe operation.
- The tow tractor must have the proper wheel base, tread width, working seat belt, and must be equipped with a roll bar to operate safely on hilly terrain. The normal operating speed is 6 MPH (9 km/h) but will vary with terrain and debris being picked up. The maximum transport speed is 20 MPH (32 km/h) with slower speeds required on hilly terrain. Refer to tractor *Operator's Manual* for information or tractor service agency if you have any question on safe operation.
- The brakes of the tow tractor must have the capacity to stop the machine with hopper fully loaded and traveling at the maximum recommended transport speed.
- Ensure that the machine complies with local road requirements when being transported on public roads. A slow moving vehicle sign has been provided. Signal lights and brakes are not provided and may be required in some areas.

Preparation

- Evaluate the terrain to determine what accessories and attachments are needed to properly and safely perform the job. Only use accessories and attachments approved by the manufacturer.
- Wear the appropriate clothing including a hard hat, safety glasses, and hearing protection. Long hair, loose clothing, or jewelry may get tangled in moving parts.
- Use extra care when handling gasoline and other fuels. They are flammable and the vapors are explosive.
 - Use only an approved container.
 - Never remove the gas cap or add fuel with the engine running.
 - Allow the engine to cool before refueling.
 - Do not smoke when handling gasoline and other fuels.
 - Never refuel or drain the machine indoors.
- Check that the operator presence controls, safety switches, and shields are attached and functioning properly. Do not operate unless they are functioning properly.
- Keep all shields, safety devices, and decals in place. If a shield, safety device, or decal is malfunctioning, illegible, or damaged, replace it before operating the machine.

Operation

- Never run an engine in an enclosed area.
- Only operate in good light, keeping away from holes and hidden hazards.
- Be sure all drives are in neutral and parking brake is engaged before starting engine. Start the engine only from the operator's position.
- Never operate without the shields, covers, or other guards securely in place. Be sure all interlocks are functioning properly.
- Stop on a level ground, empty the hopper, and block the wheels before removing the sweeper from the prime mover.
- Shut the engine off and wait for all movement to stop. The impeller may momentarily turn after other components have stopped. Use extreme caution when removing the cover from the blower housing.
- Keep hands and feet away from the sweeper area.
- Never carry passengers. Keep pets and bystanders away.

- Be alert, slow down, and use caution when making turns. Look behind and to the side of the machine before changing directions.
- Before backing up, look to the rear of the machine and ensure that no one is behind the machine.
- Slow down and use caution when crossing roads and sidewalks.
- Do not operate the machine under the influence of alcohol or drugs.
- Lightning can cause severe injury or death. If lightning is seen, or thunder is heard in the area, do not operate the machine; seek shelter.
- Use care when approaching blind corners, shrubs, trees, or other objects that may obscure vision.
- Use extreme caution around ditches, creeks, or other hazards.
- Avoid sudden stops and starts.
- If the machine vibrates abnormally, stop immediately, turn the engine off, wait for all motion to stop, and inspect for damage. Repair all of the damage before operation.
- Shut the sweeper blower off when dumping the contents of the hopper. Always stand to the extreme right or left side of the hopper when opening the tailgate.

Slope Operation

- Do not operate near drop-offs, ditches, steep banks, or water. Wheels dropping over edges can cause rollovers, which may result in serious injury or death.
- Do not operate on slopes when grass is wet. Slippery conditions reduce traction and could cause sliding and loss of control.
- Do not make sudden turns or rapid speed changes.
- Reduce speed and use extreme caution on slopes.
- Remove or mark obstacles such as rocks, tree limbs, etc. from the operating area. Tall grass can hide obstacles.
- Watch for ditches, holes, rocks, dips, and rises that change the operating angle, as rough terrain could overturn the aerator.
- Always avoid sudden starting or stopping on a slope. If tires lose traction, disengage the tines and proceed slowly off the slope.
- Follow the recommendations for wheel weights or counterweights to improve stability.

Maintenance and Storage

- Disengage the power to the machine, stop the engine, and wait for all movement to stop before adjusting, cleaning, repairing, or transporting.
- Clean the grass and debris from the rake tines, drives, mufflers, and engine to help prevent fires. Clean up any oil or fuel spillage.
- Let the engine cool before storing and do not store near flame.
- Shut off the fuel while storing or transporting on trailers. Do not store the fuel near flames or drain indoors.
- Disconnect the battery or remove the spark plug wires before making any repairs. Disconnect the negative terminal first and the positive terminal last. Reconnect the positive terminal first and the negative terminal last.
- Keep hands and feet away from any moving parts. If possible, do not make adjustments with the engine running.
- Do not overspeed the engine by changing the governor settings. To ensure safety and accuracy, have an authorized Toro distributor check the maximum engine speed with a tachometer.
- Let the engine cool before checking the oil or adding oil to the crankcase.
- Check the prime mover brakes and all safety equipment periodically.
- Charge the battery in an open, well ventilated area, away from spark and flames. Unplug the charger before connecting or disconnecting it from the battery. Wear protective clothing and use insulated tools.
- Keep all of the parts in good working condition and all hardware tightened. Replace all of the worn or damaged decals.
- Use only Toro-approved attachments. The warranty may be voided if the machine is used with unapproved attachments.

Safety and Instructional Decals



Safety decals and instructions are easily visible to the operator and are located near any area of potential danger. Replace any decal that is damaged or lost.

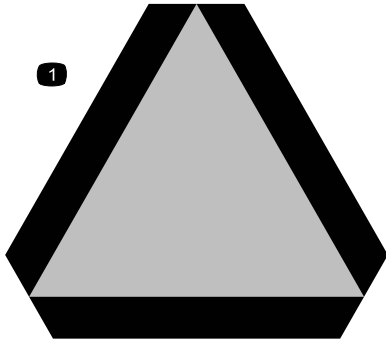

13-2930

1. Slow moving vehicle symbol



67-5360



92-8309



13-6760



13-7430



61-5950

OPERATING INSTRUCTIONS

- 1. INFLATE TIRES TO CORRECT PRESSURE.
TIRE SIZE:
11L - 14SL 28 PSI**
- 2. ADJUST HITCH TO TOW TRACTOR SO THAT FRAME IS PARALLEL WITH GROUND WHEN RAKE-O-VAC IS ON A FLAT SURFACE.**
- 3. FOR FLEX-TIP-REEL OR STREET BROOM, ADJUST COUNTERBALANCE SPRINGS TO PROVIDE 30-35 POUNDS EACH END, FOR PROPER FLOATATION.**
- 4. ADJUST GAGE WHEELS ON EACH SIDE SO FLEX-TIP-REEL FINGERS CONTACT TURF VERY LIGHTLY WITHOUT BENDING BACK AND STREET BROOM CONTACTS GROUND SURFACE WITH APPROXIMATELY 1" OF SWEEPING CONTACT WIDTH. HEAVIER CONTACT DECREASES PERFORMANCE.**
- 5. THE RUBBER FLAP SHOULD BE IN DOWN POSITION FOR MOST USEAGE. MAY BE RAISED FOR LARGE VOLUMES OF DRY TREE LEAVES.**
- 6. ALWAYS DUMP DEBRIS FROM HOPPER BEFORE REMOVING RAKE-O-VAC FROM TOW VEHICLE.**
- 7. BLOCK WHEELS WHEN DISCONNECTED FROM TOW VEHICLE AND PARK UNIT ON FLAT SURFACE.**
- 8. IF BLOWER HOUSING BECOMES BLOCKED WITH DEBRIS, STOP UNIT AND WAIT FOR IMPELLER TO COME TO A COMPLETE STOP BEFORE ATTEMPTING TO CLEAR DEBRIS.**
- 9. SEE OPERATOR'S MANUAL FOR ADDITIONAL OPERATING INSTRUCTIONS.**

93-4041

93-4041

Setup

Loose Parts

Use the chart below to verify that all parts have been shipped.

Procedure	Description	Qty.	Use
1	No parts required	–	Activate and charge the battery.
2	Bolts Locknuts	2 2	Mount sweeper to prime mover.
3	No parts required	–	Removing sweeper from prime mover.

Media and Additional Parts

Description	Qty.	Use
Operator's Manual Engine Operator's Manual	1 1	Read before operating the machine.
Parts Catalog	1	View and order parts.

Note: Determine the left and right sides of the machine from the normal operating position.



Activating and Charging the Battery

No Parts Required

Procedure

WARNING

CALIFORNIA Proposition 65 Warning

Battery posts, terminals, and related accessories contain lead and lead compounds, chemicals known to the State of California to cause cancer and reproductive harm.
Wash hands after handling.

1. Unlatch and open the battery compartment cover.
2. Remove the battery from the battery compartment.
3. Clean the top of the battery and remove the vent caps.

4. Carefully fill each cell with electrolyte until the electrolyte is up to the fill line.

Use only electrolyte (1.260 Specific Gravity) to fill the battery initially.

Important: Do not add electrolyte while the battery is in the machine. You could spill it, causing corrosion.

▲ DANGER

Battery electrolyte contains sulfuric acid which is a deadly poison and causes severe burns.

- Do not drink electrolyte and avoid contact with skin, eyes, or clothing. Wear safety glasses to shield your eyes and rubber gloves to protect your hands.
 - Fill the battery where clean water is always available for flushing the skin.
5. Connect a 3 to 4 amp battery charger to the battery posts. Charge the battery at a rate of 3 to 4 amps for 4 to 8 hours.
 6. Remove the filler caps and slowly add electrolyte to each cell until the level is up to the fill line. Install the filler caps.

Important: Do not overfill the battery. Electrolyte will overflow onto other parts of the machine and severe corrosion and deterioration will result.

⚠ WARNING

Charging the battery produces gasses that can explode.

Never smoke near the battery and keep sparks and flames away from the battery.

- When the battery is charged, disconnect the charger from the electrical outlet and battery posts. Allow the battery to sit for 5 to 10 minutes before proceeding to the next step.

Note: After the battery has been activated, add only distilled water to replace normal loss, although maintenance-free batteries should not require water under normal operating conditions.

- Insert the battery into the tray in the battery compartment. Position the battery so that the terminals are to the outside.

⚠ WARNING

Battery terminals or metal tools could short against metal machine components causing sparks. Sparks can cause the battery gasses to explode, resulting in personal injury.

- When removing or installing the battery, do not allow the battery terminals to touch any metal parts of the machine.
 - Do not allow metal tools to short between the battery terminals and metal parts of the machine.
- Slide the battery into the battery box with the terminals to the inside.

⚠ WARNING

Battery terminals or metal tools could short against metal tractor components causing sparks. Sparks can cause the battery gasses to explode, resulting in personal injury.

- When removing or installing the battery, do not allow the battery terminals to touch any metal parts of the tractor.
 - Do not allow metal tools to short between the battery terminals and metal parts of the tractor.
- Attach the positive cable (red cable from the ignition switch) to the positive (+) terminal.
 - Attach the negative cable (black cable from the engine block) to the negative (-) terminal of the battery.

Important: Make sure there is clearance between the battery cables and the speed selector lever. Verify that the speed selector lever does not come within 1 inch (2.5 cm) of either battery cable when it is moved through its entire range of motion. Do not wire tie or tape the negative and positive battery cables together.

⚠ WARNING

Incorrect battery cable routing could damage the machine and cables causing sparks. Sparks can cause the battery gasses to explode, resulting in personal injury.

- Always *disconnect* the negative (black) battery cable before disconnecting the positive (red) cable.
- Always *connect* the positive (red) battery cable before connecting the negative (black) cable.

- Coat the terminals and mounting fasteners with petroleum jelly to prevent corrosion.
- Install the battery cover and secure it with the springs.

2

Mount the Sweeper to the Prime Mover

Parts needed for this procedure:

2	Bolts
2	Locknuts

Procedure

To ensure proper debris pickup, make sure the sweeper frame is parallel with the ground.

- Position the machine on a flat, level surface.
- Insert the sweeper jack caster wheel onto the sweeper end of the jack tube.
- Adjust the sweeper jack so that the distance from the top of the frame to the ground is approximately 23-1/2 inches (59.69 cm) (Figure 3).

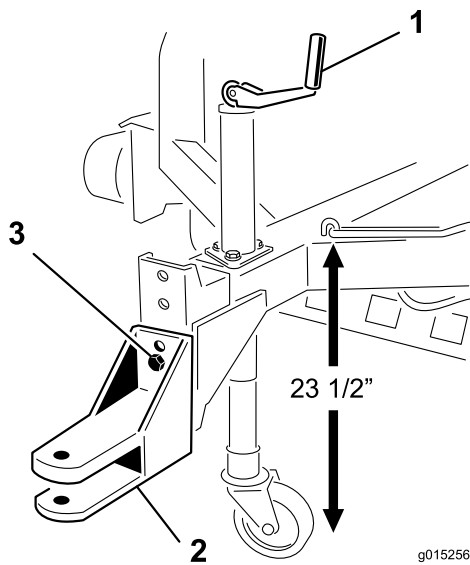

Figure 3

g015256

- | | |
|-------------------------------|---------------------|
| 1. Sweeper jack | 3. Adjusting screws |
| 2. Hitch tongue (Model 07050) | |

3. Raise the sweeper jack handle and lower the caster wheel to ground.
4. Continue to raise the sweeper with a jack until the hair pin cotter and hitch pin can be removed from the hitch.

4. Back the prime mover up to the sweeper.
5. Adjust the sweeper hitch tongue to the same level as the hitch of the prime mover as follows:
 - Remove the bolts and locknuts securing the hitch tongue to the frame.
 - Raise or lower the hitch tongue to the position approximately level with the prime mover hitch and secure it with the 2 bolts and locknuts.

3

Removing Sweeper from the Prime Mover

No Parts Required

Procedure

Important: Always empty the sweeper hopper before disconnecting the hopper from the prime mover or the sweeper may tip backwards and cause injury.

1. Park the sweeper on a level surface and block the wheels.
2. Insert the castor wheel onto the jack tube.

Product Overview

Controls

Flap Lever

Move the flap lever downward to the engaged position and upward for the disengaged position. Move the lever to the upward position when transporting the machine.

Reel Lever

Push the reel lever forward to raise the flex tip reel. To lower the flex reel, push the lever forward until the catch releases, then push to the rear until the lever hits Stop. Move the lever to the raised position when the machine is not in operation, when storing the machine, or when transporting the machine (Figure 4).

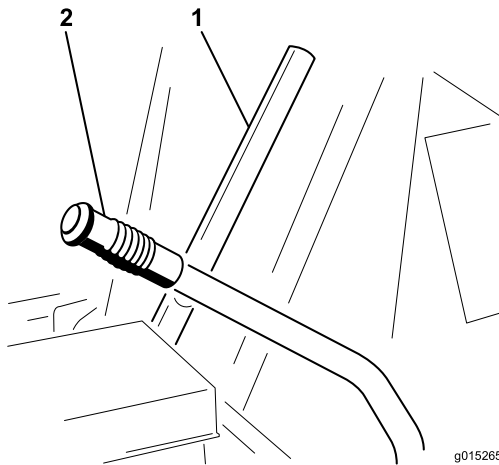

Figure 4

1. Flap lever
2. Reel lever

Choke Control

To start a cold engine, close the carburetor choke by moving the choke control lever to the On position. After the engine starts, regulate the choke to keep the engine running smoothly. Open the choke by moving the lever to the Off position. Starting a warm engine requires little or no choking (Figure 5).

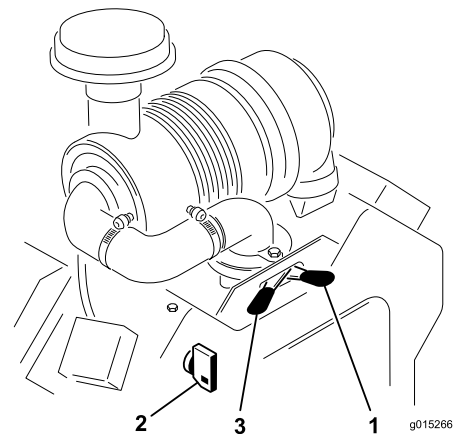

Figure 5

1. Choke control
2. Ignition switch
3. Throttle control

Ignition Switch

The ignition switch, which is used to start and stop the engine, has three positions: Off, Run, and Start. Rotate the key clockwise to the Start position to engage the starter motor. Release the key when the engine starts. The key will move automatically to the Run position. To shut the engine off, rotate the key counterclockwise to the Off position.

Throttle Control

The throttle is used to operate the engine at various speeds. Moving the throttle lever to the Fast position increases the engine speed. To decrease the engine speed, move the lever to the Slow position.

Tailgate Latch Rope

Pull the tailgate latch rope to unlatch the tailgate when emptying the hopper (Figure 6).

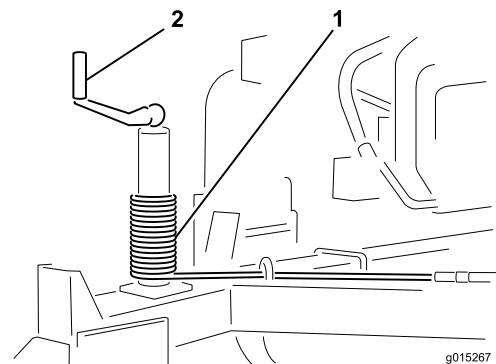

Figure 6

1. Tailgate latch rope
2. Jack handle

Specifications

Note: Specifications and design are subject to change without notice.

Width	85.5 inches (217.17 cm)
Length	159 inches (403.86 cm)
Height	79.5 inches (201.93 cm)
Empty Weight	2160 lbs (979.76 kg)

Operation

Note: Determine the left and right sides of the machine from the normal operating position.

Adding Fuel

Use unleaded gasoline (85 pump octane minimum). Leaded, regular gasoline may be used if unleaded is not available.

⚠ DANGER

In certain conditions, gasoline is extremely flammable and highly explosive. A fire or explosion from gasoline can burn you and others and can damage property.

- Fill the fuel tank outdoors, in an open area, when the engine is cold. Wipe up any gasoline that spills.
- Do not fill the fuel tank completely full. Add gasoline to the fuel tank until the level is 1 inch (25 mm) below the bottom of the filler neck. This empty space in the tank allows gasoline to expand.
- Never smoke when handling gasoline, and stay away from an open flame or where gasoline fumes may be ignited by a spark.
- Store gasoline in an approved container and keep it out of the reach of children. Never buy more than a 30-day supply of gasoline.
- Do not operate without the entire exhaust system in place and in proper working condition.

⚠ DANGER

In certain conditions during fueling, static electricity can be released causing a spark which can ignite the gasoline vapors. A fire or explosion from gasoline can burn you and others and can damage property.

- Always place gasoline containers on the ground away from your vehicle before filling.
- Do not fill gasoline containers inside a vehicle or on a truck or trailer bed because interior carpets or plastic truck bed liners may insulate the container and slow the loss of any static charge.
- When practical, remove gas-powered equipment from the truck or trailer and refuel the equipment with its wheels on the ground.
- If this is not possible, then refuel such equipment on a truck or trailer from a portable container, rather than from a gasoline dispenser nozzle.
- If a gasoline dispenser nozzle must be used, keep the nozzle in contact with the rim of the fuel tank or container opening at all times until fueling is complete.

Important: Do not use methanol, gasoline containing methanol, or gasohol containing more than 10% ethanol because the fuel system could be damaged. Do not mix oil with gasoline.

⚠ WARNING

Gasoline is harmful or fatal if swallowed. Long-term exposure to vapors can cause serious injury and illness.

- Avoid prolonged breathing of vapors.
- Keep face away from nozzle and gas tank or conditioner opening.
- Keep gas away from eyes and skin.

Filling the Fuel Tank

The fuel tank capacity is approximately 4 gal (15.14 l).

1. Clean around the fuel tank cap and remove it.

2. Fill the tank to approximately 1 inch below the top of the tank (the bottom of the filler neck).

Important: This space in the tank allows gasoline to expand. Do not fill the fuel tank completely full.

3. Install the fuel tank cap securely.
4. Wipe up any gasoline that may have spilled.

Checking the Engine Oil Level

Service Interval: Before each use or daily (Check the oil when the engine is cold.)

The engine is shipped with oil in the crankcase; however, the oil level must be checked before and after the engine is first started.

Crankcase capacity is approximately 2 qt. (1.9 l) with the filter.

Use high-quality engine oil as described in Changing the Engine Oil and Filter (page 19).

Note: The best time to check the engine oil is when the engine is cool before it has been started for the day. If it has already been run, allow the oil to drain back down to the sump for at least 10 minutes before checking. If the oil level is at or below the add mark on the dipstick, add oil to bring the oil level to the full mark. **Do not** overfill. If the oil level is between the full and add marks, no oil addition is required.

1. Park the machine on a level surface, stop the engine, remove the key, and wait for all moving parts to stop before leaving the operating position.
2. Clean around the oil dipstick so that dirt cannot fall into the filler hole and damage the engine (Figure 7).

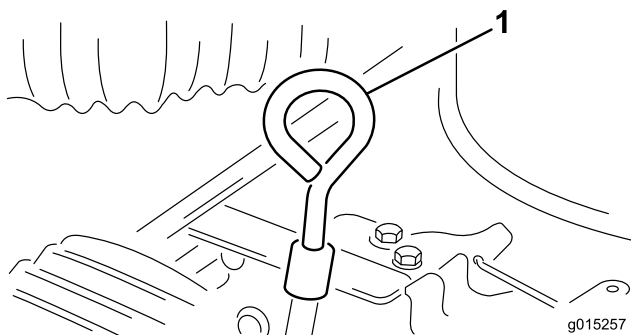

Figure 7

1. Dipstick
-
3. Remove the dipstick, wipe it clean, and install it until it is fully seated.
 4. Remove the dipstick and check the oil level on the dipstick.

The oil level should be up to the Full mark on the metal end of the dipstick.

5. If the oil level is below the Full mark, remove the filler tube cap and add oil until the level reaches the Full mark on the dipstick (Figure 8). **Do not** overfill.

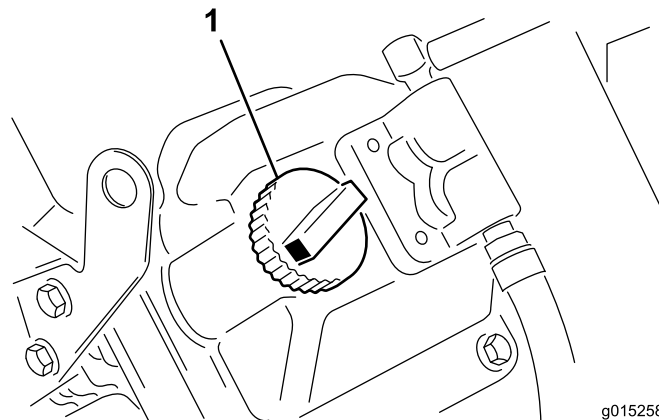

Figure 8

1. Filler cap

Important: Do not overfill the crankcase with oil because this may cause engine damage. Do not run the engine with oil below the low mark because the engine may be damaged as a result.

6. Install the filler tube cap and dipstick.

Starting and Stopping the Engine

Starting the Engine

1. Place all of the controls in the Off or Disengaged position.
2. Move the throttle lever midway between the Slow and Fast position.
3. Move the choke lever to the On position.

Note: Choke is not required when starting a warm engine.

4. Insert the key into the ignition switch and rotate it clockwise to start the engine. Release the key when the engine starts. Regulate the choke to keep the engine running smoothly.

Important: To prevent overheating of the starter motor, do not engage the starter longer than 10 seconds. After 10 seconds of continuous cranking, wait 60 seconds before engaging the starter motor again.

5. Move the throttle lever to the desired engine speed.

- Pull the flap lever as far forward as possible.
- Push the reel lever forward until the catch releases, then push it to the rear until the lever hits Stop.

Note: Do not allow the sweeper to stand still with the rake engaged as turf damage may occur.

Stopping the Engine

- Move the throttle lever to the Slow position.
- Let the engine idle for 60 seconds.
- Turn the ignition key to the Off position and remove the key.

Note: To stop the machine in an emergency, move the ignition switch to the Off position.

Transporting the Machine

- Lift each end of the reel and remove the transport hooks before operating the machine (Figure 9).

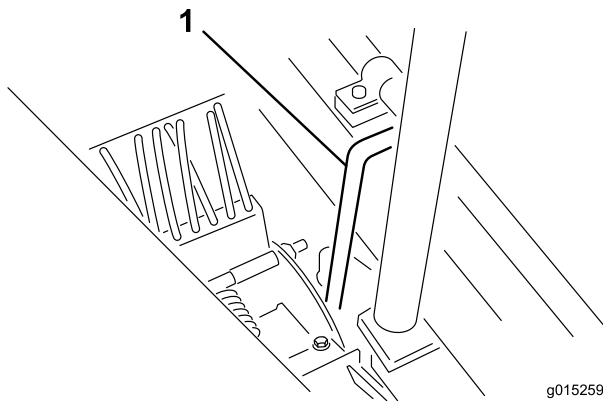

Figure 9

- Transport hook

- Support the flex tip reel, broom, or thatching reel with the transport hooks.

Adjusting the Reel Support Arm

The gauge wheel should ride over the turf evenly. If the reel support arm has a tendency to bounce, the spring setting is too tight. If the gauge wheel scars the turf, the spring setting is too loose.

- Pull the rake lever rearward to lower the flex tip reel or broom (Figure 10).

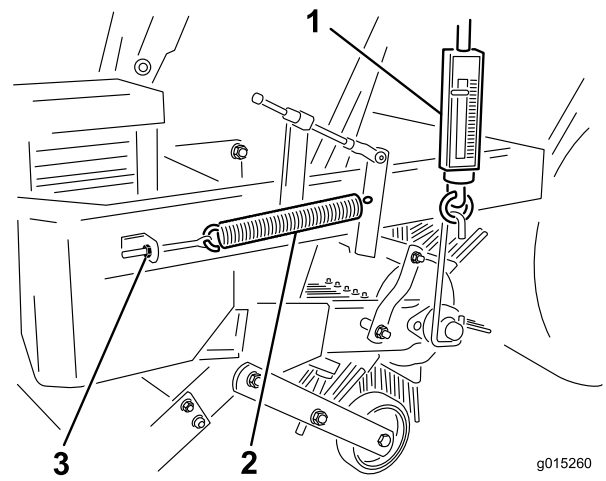

Figure 10

- Spring scale
- Counterbalance spring
- Adjustment screw

- Position a spring scale on the transport hook and lift it up. The tension necessary to lift the gauge wheel off the ground should be 30–50 lbs (13–23 kg).
- If the tension is not 30–50 lbs (13–23kg), adjust the tension by tightening or loosening the adjustment screw on the counterbalance spring.
- Perform this procedure on both sides of the sweeper.

Note: Because of the added weight of the drive components, the spring on the right side of the machine will require a tighter setting than the spring on the left side of the machine.

Adjusting the Rake Depth

The flex tip reel should be adjusted to ensure that the rake tips slightly touch surface but do not penetrate the turf. If the rake tips penetrate the turf, improper debris pickup could result.

- Position the machine on a level surface.
- Loosen the locknut on the depth adjustment bolt so that it can be turned (Figure 11).

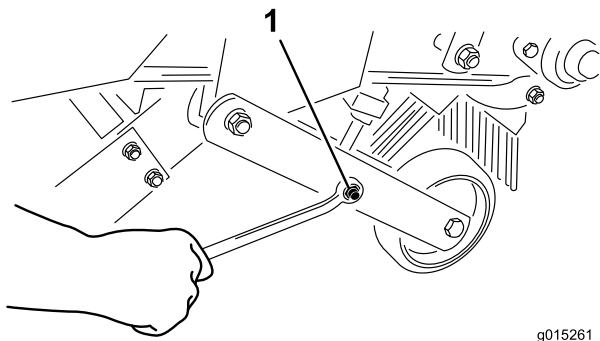

Figure 11

g015261

1. Locknut

3. Turn the depth adjustment bolt until the rake slightly contacts the top of the turf grass. If a broom is installed, slight contact should be made with the surface. When the broom is operating, the contact width surface should be about 1 inch (25.4 mm) wide across the entire length of the broom (Figure 12).

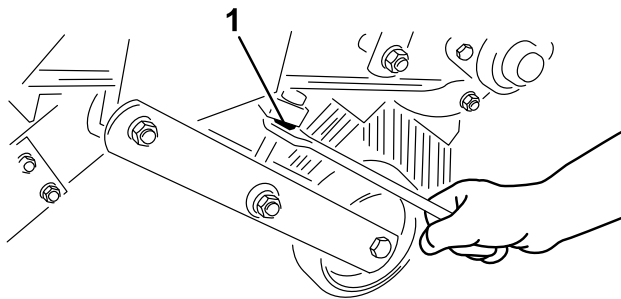

Figure 12

g015262

1. Depth adjusting bolt

4. Repeat the procedure on the opposite side of the machine.
5. Tighten the adjustment lock nut.

Adjust the Rubber Flap

For the best debris pick up results, the metal portion of the front flap should be vertical to the ground.

1. Move the flat lever forward to lower the flat (Figure 13).

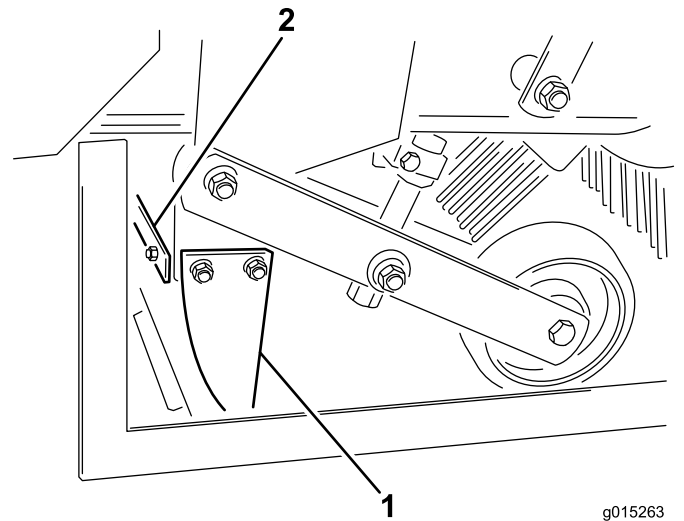

Figure 13

g015263

1. Rubber flap
2. Metal edge

2. Loosen the jam nut on top of the stop and rotate the adjustment bolt up or down until the flap is vertical to the ground (Figure 14).

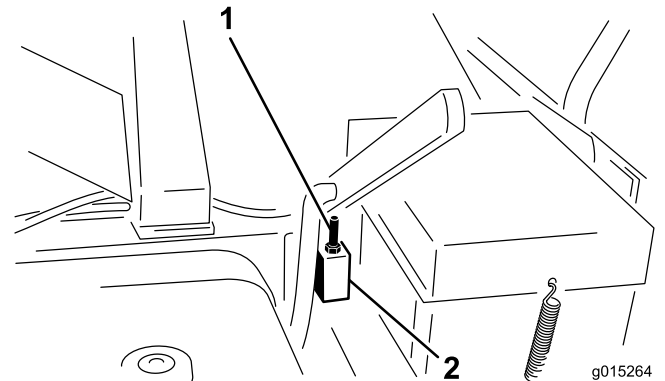

Figure 14

g015264

1. Adjustment bolt
2. Stop

3. Tighten the jam nut to secure the adjustment.

Note: The flap may be positioned in raised position when picking up large amounts of leaves.

Inspect and Cleanup after Operation

When the sweeping has been completed, thoroughly clean and wash the machine. Air out the dry hopper. After cleaning, it is recommended that the machine be inspected for possible damage to the mechanical components and blower. These procedures will ensure that the machine will perform satisfactorily during the next sweeping operation.

Important: When towing the sweeper for long distances, fasten the gauge wheel arm securely

to the sweeper frame with the transport hooks. Should the gauge wheel arm fall to the ground, damage to the sweeper may occur.

Operating Tips

General

- Before starting to sweep, survey area to determine the best direction to sweep.
Note: To maintain a straight line when sweeping, sight of an object in the foreground.
- Always try to make a long, continuous run with a slight overlap on the return run.
- On turf areas, the flex tip reel will pick up twigs, clippings, leaves, pine needles and cones, small debris (beverage cans, small bottles, paper plates, etc.).
- The rake teeth are made of flexible nylon and easily changed. To prevent damage, the rake is protected from solid obstructions by spring action. The nylon teeth will not mar bronze, stone markers, sidewalks or pavement.
- Because of its unique design, the sweeper also grooms the turf. The flex tip reel combs through and lifts grass for a uniform cut when mowed. As it cleans, the light scarifying action increase water and pesticide penetration, thus reducing the need for renovation.

Important: Do not make sharp turns when using the thatching reel as damage to turf may occur.

Important: Do not operate sweeper while reel is turning and in the raised position. Damage to the rake and tires may result if teeth come in contact with tires.

- To empty hopper, pull tailgate latch rope.

⚠ CAUTION

This product may exceed noise levels of 85 dB(A) at the operator position. Ear protectors are recommended, for prolonged exposure, to reduce the potential of permanent hearing damage.

Maintenance

Note: Determine the left and right sides of the machine from the normal operating position.

Important: Refer to your engine *Operator's Manual* for additional maintenance procedures.

Recommended Maintenance Schedule(s)

Maintenance Service Interval	Maintenance Procedure
After the first 50 hours	<ul style="list-style-type: none">• Change the engine oil and filter.
Before each use or daily	<ul style="list-style-type: none">• Check the engine oil level. (Check the oil when the engine is cold.)• Check the tire pressure.
Every 25 hours	<ul style="list-style-type: none">• Lubricate the bearings.• Service the Air Cleaner.• Check the electrolyte level and clean the battery.• Check the battery cable connections.
Every 50 hours	<ul style="list-style-type: none">• Oil the Sweeper Jack.
Every 100 hours	<ul style="list-style-type: none">• Change the engine oil and filter.• Remove debris from engine.
Every 200 hours	<ul style="list-style-type: none">• Check the spark plugs.
Every 600 hours	<ul style="list-style-type: none">• Replace the fuel filter.
Before storage	<ul style="list-style-type: none">• Refer to the Storage section for procedures necessary to perform before storing the machine for more than 30 days.

Lubrication

Lubrication

Service Interval: Every 25 hours

The Rake-O-Vac has grease fittings that must be lubricated regularly with No. 2 General Purpose Lithium Base Grease. Lubricate the bearings after every 30 hours of operation or whenever machine is washed with water. Bearings and bushings must be lubricated daily when operating conditions are extremely dusty and dirty. Dusty and dirty operating conditions could cause dirt to get into the bearings and bushings, resulting in accelerated wear. The grease fittings that must be lubricated are: the gauge wheel bearings, the reel shaft bearings, the impeller shaft bearings, the jackshaft bearings, and the left and right trailing arms.

1. Wipe the grease fittings clean to ensure that foreign matter cannot be forced into the bearing or bushing.
2. Pump grease into the bearing or bushing (Figure 15, Figure 16, and Figure 17).

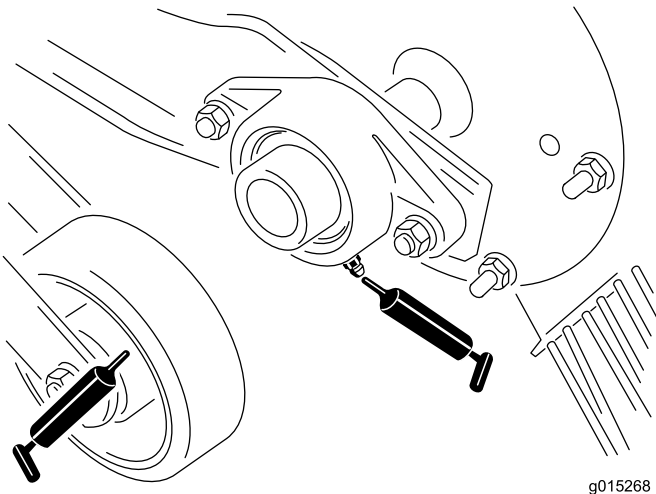

Figure 15

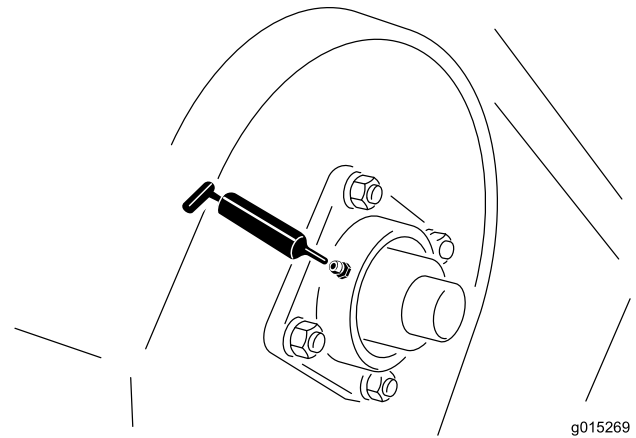

Figure 16

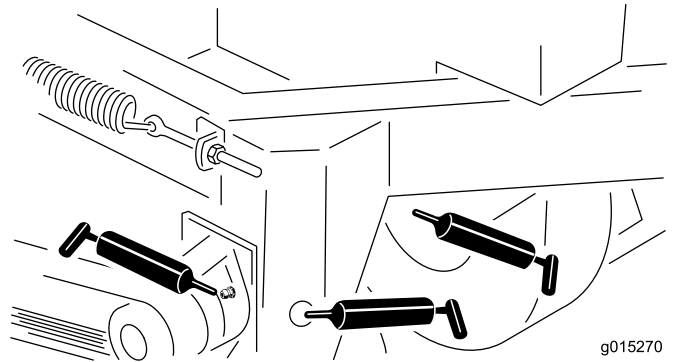

Figure 17

3. Wipe up any excess grease.

Oil the Sweeper Jack

Service Interval: Every 50 hours—Oil the Sweeper Jack.

Oil the Sweeper jack after every 50 hours of operation (Figure 18).

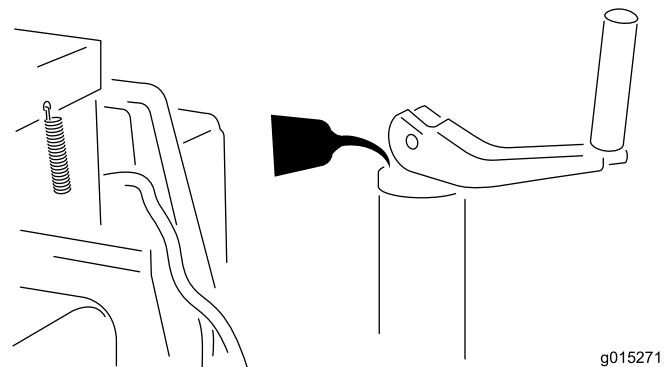

Figure 18

Engine Maintenance

Servicing the Air Cleaner

Service Interval: Every 25 hours

1. Release the latches securing the air cleaner cover to the air cleaner body. Separate the cover of the air cleaner from the body of the unit. Clean the inside of the air cleaner cover (Figure 19).

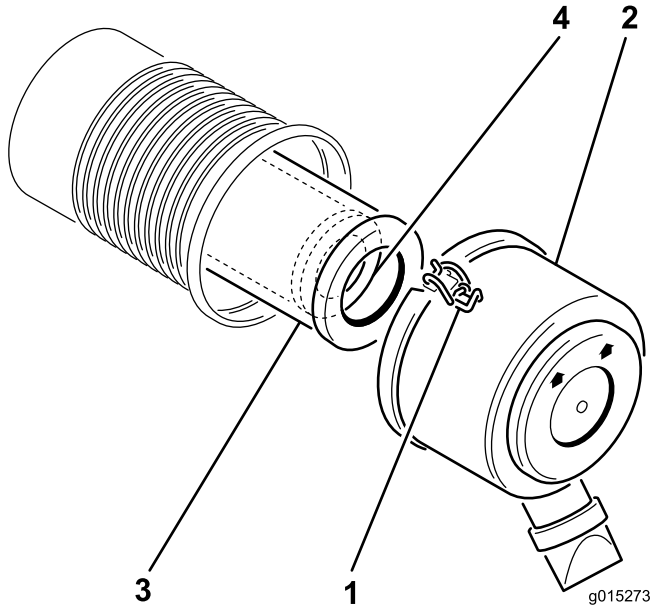

Figure 19

- | | |
|------------------------|-------------------|
| 1. Air cleaner latches | 3. Primary filter |
| 2. Dust cup | 4. Safety filter |

2. Gently slide the primary filter out of the air cleaner body to reduce the amount of dust dislodged. Avoid knocking the filter against the air cleaner body. Do not remove the safety filter.
3. Inspect the primary filter and replace it if there is damage. Do not wash or reuse a damaged filter.
Important: Do not attempt to clean the safety filter. Replace the safety filter with a new one after every 3 primary filter services.
4. Blow compressed air from the inside to the outside of the dry filter element. Do not exceed 100 psi to prevent damage to the element.
5. Keep the air hose nozzle at least 2 inches from the filter and move the nozzle up and down while rotating the filter element. Inspect the filter for holes and tears by looking through the filter toward a bright light.
6. Inspect the new filter for any shipping damages. Check the sealing end of the filter. Do not install a damaged filter.

7. Insert the new filter properly into the air cleaner body. Make sure the filter is sealed properly by applying pressure to the outer rim of the filter when installing. Do not press on the flexible center of the filter.
8. Reinstall the cover and secure the latches. Make sure the cover is positioned with the top side up.

Changing the Engine Oil and Filter

Service Interval: After the first 50 hours

Every 100 hours—Change the engine oil and filter.

Note: Change the oil and filter more frequently when operating conditions are extremely dusty or sandy.

Oil Type: Detergent oil (API service SJ, SK, SL, or higher)

Crankcase Capacity: w/filter, 2.0 qt. (1.9 l)

1. Start the engine and let it run for five minutes. This warms the oil so it drains better.
2. Park the machine so that the drain side is slightly lower than the opposite side to ensure that the oil drains completely.
3. Set the parking brake, stop the engine, and remove the key.
4. Place a pan below the oil drain. Remove the oil drain plug to allow the oil to drain (Figure 20).

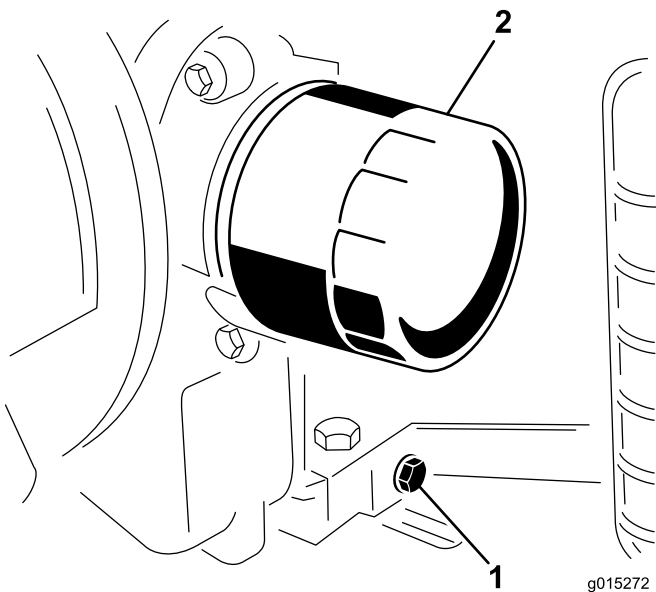

Figure 20

1. Drain plug 2. Oil filter

5. When the oil has drained completely, replace the plug.
Note: Dispose of the used oil at a certified recycling center.
6. Place a shallow pan or rag under the filter to catch oil.
7. Remove the old filter and wipe the surface of the filter adapter gasket.
8. Pour the new oil of the proper type through the center hole of the filter. Stop pouring when the oil reaches the bottom of the threads.
9. Allow a minute or two for the oil to be absorbed by filter material, then pour off the excess oil.
10. Apply a thin coat of new oil to the rubber gasket on the replacement filter.
11. Install the replacement oil filter to the filter adapter. Turn the oil filter clockwise until the rubber gasket contacts the filter adapter, then tighten the filter an additional 1/2 turn. **Do not** over tighten.
12. Check the oil level; refer to Checking the Engine Oil Level (page 13).
13. Slowly add additional oil to bring the level to the full mark on the dipstick.
14. Replace the fill cap.

Servicing the Spark Plugs

Service Interval: Every 200 hours—Check the spark plugs.

Ensure that the air gap between the center and side electrodes is correct before installing each spark plug.

Use a spark plug wrench for removing and installing the spark plugs and a gapping tool/feeler gauge to check and adjust the air gap. Install new spark plugs if necessary.

Type: Champion RC12YC or equivalent. Air Gap: 0.03 inch (0.75 mm)

Removing the Spark Plugs

1. Stop the engine, set the parking brake, and remove the key.
2. Pull the wires off of the spark plugs.
3. Clean around the spark plugs.
4. Remove both spark plugs and metal washers.

Checking the Spark Plugs

1. Look at the center of both spark plugs (Figure 21). If you see light brown or gray on the insulator, the engine is operating properly. A black coating on the insulator usually means the air cleaner is dirty.

Important: Never clean the spark plugs. Always replace the spark plugs when they have a black coating, worn electrodes, an oily film, or cracks.

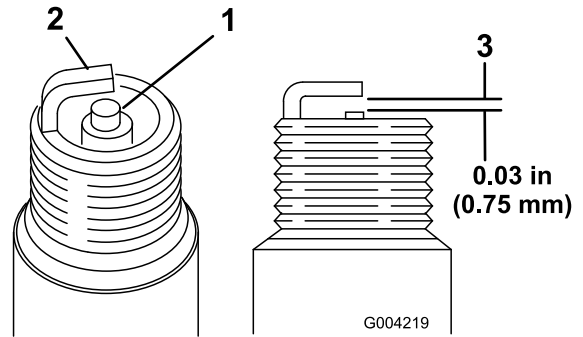

Figure 21

1. Center electrode insulator
 2. Side electrode
 3. Air gap (not to scale)
2. Check the gap between the center and side electrodes (Figure 21).
 3. Bend the side electrode (Figure 21) if the gap is not correct.

Installing the Spark Plugs

1. Thread the spark plugs into the spark plug holes.
2. Tighten the spark plugs to 20 ft-lb (27 N-m).
3. Push the wires onto the spark plugs.

Remove Debris from the Engine

Service Interval: Every 100 hours

To ensure proper cooling, keep the grass screen, cooling fins, and other external surfaces of the engine clean at all times.

Every 100 hours of operation (more often under extremely dusty, dirty conditions) remove the blower housing and other cooling shrouds. Clean the cooling fins and external surfaces as necessary. Make sure the cooling shrouds are reinstalled.

Note: Operating the engine with a blocked grass screen, dirty or plugged cooling fins, or cooling shrouds removed, will cause engine damage due to overheating.

Fuel System Maintenance

Replacing the Fuel Filter

Service Interval: Every 600 hours/Yearly (whichever comes first)

Important: Never install a dirty filter if it is removed from the fuel line.

1. Allow the machine to cool down.
2. Place a clean container under the fuel filter (Figure 22).

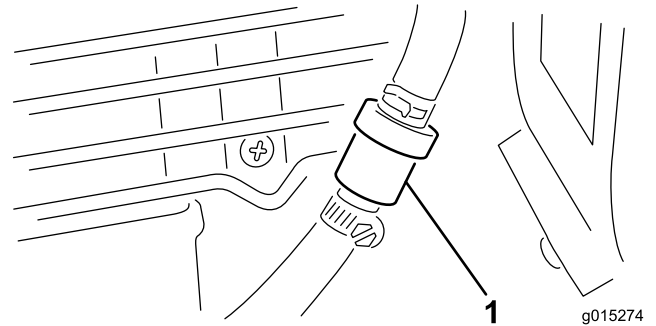

Figure 22

1. Fuel filter

-
3. Remove the clamps securing the fuel filter to the fuel lines.
 4. Install a new filter to the fuel lines with the clamps previously removed. Filter is to be mounted so that the arrow points toward the carburetor.
 5. Wipe up any spilled fuel.

Electrical System Maintenance

Servicing the Battery

Service Interval: Every 25 hours—Check the electrolyte level and clean the battery.
Every 25 hours—Check the battery cable connections.

WARNING

CALIFORNIA Proposition 65 Warning

Battery posts, terminals, and related accessories contain lead and lead compounds, chemicals known to the State of California to cause cancer and reproductive harm.
Wash hands after handling.

⚠ DANGER

Battery electrolyte contains sulfuric acid which is a deadly poison and causes severe burns.

- Do not drink electrolyte and avoid contact with skin, eyes, or clothing. Wear safety glasses to shield your eyes and rubber gloves to protect your hands.
- Fill the battery where clean water is always available for flushing the skin.

The battery electrolyte level must be properly maintained and the top of the battery kept clean. If the machine is stored in a location where temperatures are extremely high, the battery will run down more rapidly than if the machine is stored in a location where temperatures are cool.

Check the electrolyte level every 25 operating hours or, if machine is in storage, every 30 days.

Maintain the cell level with distilled or demineralized water. Do not fill the cells above the bottom of the split ring inside each cell.

Keep the top of the battery clean by washing it periodically with a brush dipped in ammonia or bicarbonate of soda solution. Flush the top surface with water after cleaning. Do not remove the fill caps while cleaning.

The battery cables must be tight on the terminals to provide good electrical contact.

⚠ WARNING

Incorrect battery cable routing could damage the machine and cables causing sparks. Sparks can cause the battery gasses to explode, resulting in personal injury.

- Always *disconnect* the negative (black) battery cable before disconnecting the positive (red) cable.
- Always *connect* the positive (red) battery cable before connecting the negative (black) cable.

If corrosion occurs at the terminals, disconnect the cables (negative (–) cable first) and scrape clamps and terminals separately. Reconnect the cables (positive (+) cable first) and coat the terminals with petroleum jelly.

⚠ WARNING

Battery terminals or metal tools could short against metal tractor components causing sparks. Sparks can cause the battery gasses to explode, resulting in personal injury.

- When removing or installing the battery, do not allow the battery terminals to touch any metal parts of the machine.
- Do not allow metal tools to short between the battery terminals and metal parts of the machine.

Drive System Maintenance

Tire Maintenance

Checking the Tire Pressure

Service Interval: Before each use or daily

Maintain the air pressure in the front and rear tires at 28 psi (193 kPa). Check the pressure at the valve stem (Figure 23) before each use.

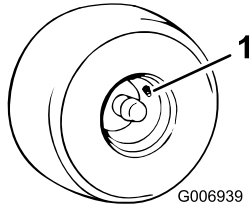

Figure 23

1. Valve stem

Changing the Tires

1. Park the machine on a flat, level surface. Block the other tire to prevent accidental rolling or injury.
2. Place the jack under the frame or axle shaft behind the wheel and jack up the wheel until it just contacts the floor.

⚠ WARNING

A 2000 lb. capacity hydraulic jack should be used when changing a tire.

3. Loosen all lug bolts and continue to jack up until the tire can be removed.
4. Reverse the above procedure to install a tire. Torque the lug bolts to 70–90 ft-lb (95–122 N-m).

Belt Maintenance

Inspecting the Belts

Note: It is not necessary to remove the upper belt guard (Figure 24) to check the belt tension. If for some reason the belt guard must be removed, remove the 4 bolts, washers, and nuts securing the guard to the frame. Never operate the machine without the guards in place.

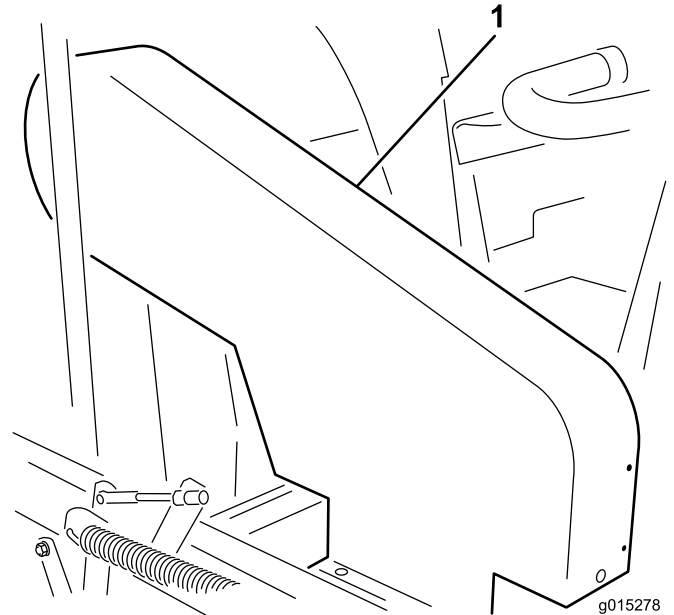

Figure 24

1. Upper belt guard

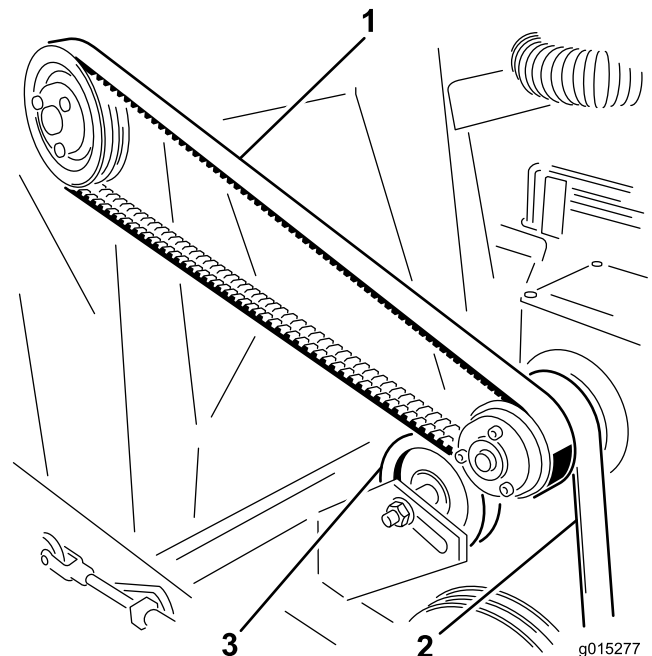

Figure 25

1. Impeller belt
2. Jackshaft belt
3. Idler pulley

Inspecting the Impeller Drive Belt

Check the tension by depressing the belt at the mid span of the impeller and clutch pulleys with 4–5 lbs (1.81–2.27 kg) of force. The belt should deflect .5 inches (1.27 cm). If the deflection is incorrect, proceed to Adjusting the Impeller Drive Belt (page 24). If the deflection is correct, continue normal operation (Figure 24).

Inspecting the Jackshaft Belt

Check the tension by depressing the belt at mid span of the jackshaft and clutch pulleys with 4–5 lbs (1.81–2.27 kg) of force. The belt should deflect .25 inches (6.35 mm). If the deflection is incorrect, proceed to Adjusting the Jackshaft Belt (page 24). If the deflection is correct, continue normal operation (Figure 24).

Inspecting the Reel Drive Belt

Check the tension by depressing the belt at mid span of the idler pulley and the reel driver pulley with 25–29 lbs (11.34–13.15 kg) of force. The belt should deflect .25 inches (6.35 mm). If the deflection is incorrect, proceed to Adjusting the Reel Drive Belt (page 24). If the deflection is correct, continue normal operation.

Adjusting the Belts

Adjusting the Impeller Drive Belt

1. Loosen the engine mounting bolts (Figure 26).

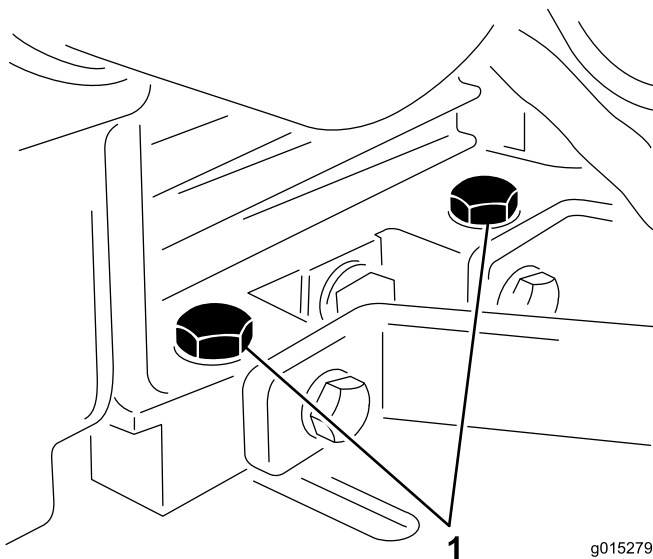

Figure 26

1. Engine mounting bolts

mounting bolts. Adjust the engine so that it is parallel with frame. Continue tightening the engine mounting bolts (Figure 27).

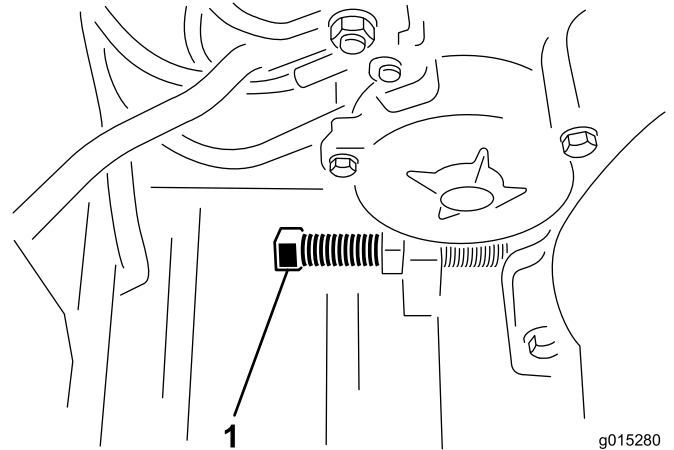

Figure 27

1. Adjusting bolt

3. Whenever the impeller belt is adjusted it is necessary to readjust the jackshaft belt (engine drive) or chain (PTO drive).

Adjusting the Jackshaft Belt

1. Remove the 4 bolts, washers and nuts securing the upper shroud to the frame (Figure 24).
2. If the belt has too much slack, loosen the idler pulley nut, press forward on the idler pulley until the desired tension is obtained and retighten the idler pulley nut.
3. If the belt is too tight, loosen the idler pulley nut, pull rearward on the idler pulley until the desired tension is obtained and tighten the idler pulley nut.

Adjusting the Reel Drive Belt

1. Remove the 2 bolts, nut, retaining nut, and washer securing the lower belt guard to the frame. Remove the guard (Figure 28).

2. Turn the belt adjusting bolt until the desired belt tension is obtained. Slightly tighten the engine

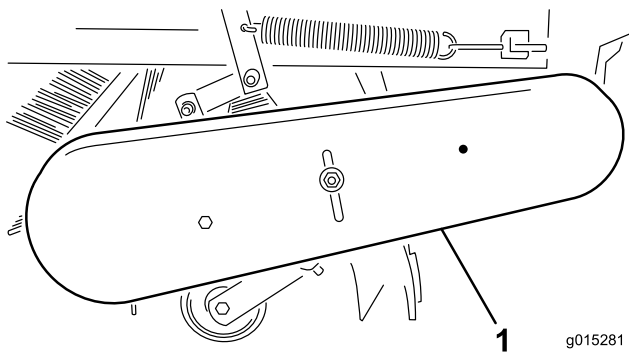

Figure 28

1. Lower belt guard

2. If the belt has too much slack, loosen the idler pulley nut, press down on the idler pulley until the desired tension is obtained and tighten the idler pulley nut (Figure 29).

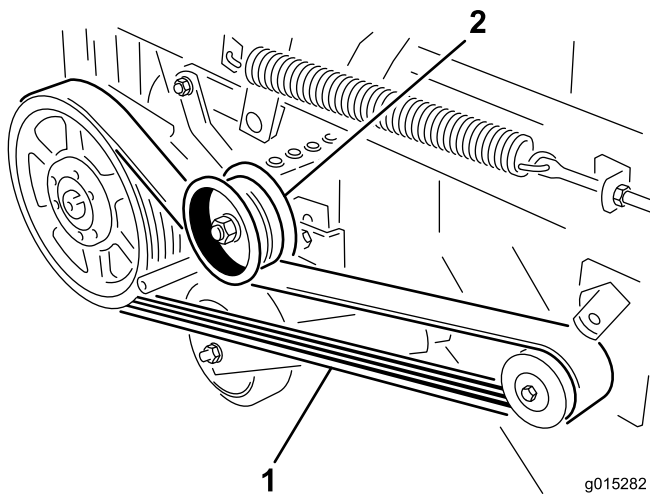

Figure 29

1. Reel drive belt
2. Idler pulley

3. If the belt is too tight, loosen the idler pulley nut, pull upward on the idler pulley until the desired tension is obtained and tighten the idler pulley nut.
4. Install the belt guard. Ensure that there is clearance between the belt and the belt guard.

Changing the Rubber Flap

Replace the rubber flap when it becomes worn or damaged.

CAUTION

Change rubber flap on a flat, level surface and block wheels to prevent sweeper from rolling. Failure to do so may result in personal injury.

1. Remove the 10 bolts, washers, and nuts on the mounting flap and flap retainer (Figure 30).

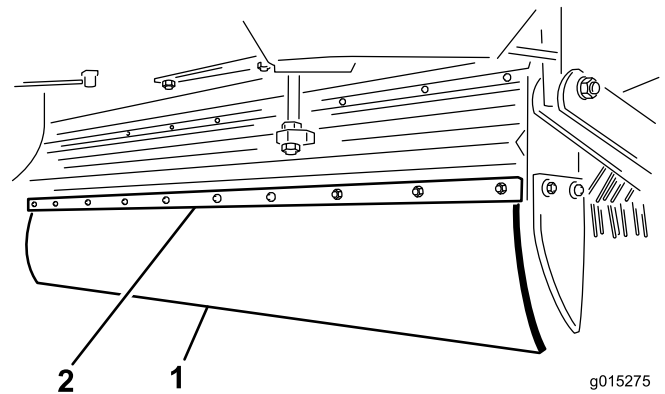

Figure 30

1. Rubber flap
2. Flap retainer

2. Replace with the new rubber flap and fasten it securely.

Pulley Removal

1. Remove the bolts and lockwashers one at a time and screw them into the adjoining holes (Figure 31).

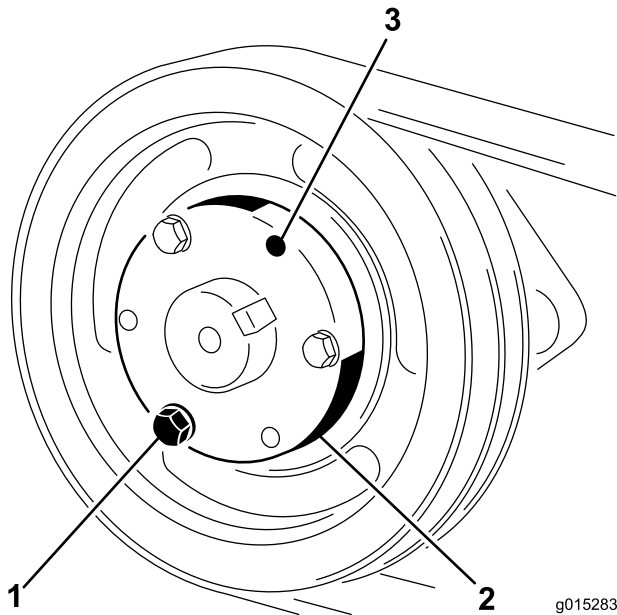

Figure 31

1. bolts & locknuts
2. Taper lock bushing
3. Taper lock release hole

2. Turn each bolt the same number of times until the lock separates. The pulley will now slide off of the shaft.

Flex Tip Reel Removal

1. Place the machine on a hard and level surface.
2. Raise the front of the sweeper as high as possible by lowering the jack.
3. Raise the reel to the highest position.
4. Remove the lower belt guard and reel drive belt (Figure 28 and Figure 29).
5. Remove the 2 bolts, lockwashers, and nuts securing the reel shaft bearings to the reel support arms on each side of the sweeper. Lower the flex tip reel to the ground.
6. Lift the reel support arms to the highest position.
7. Slide the end of the rake rearward and pull it out from under the machine.

Thatcher Installation

A 32 tooth jackshaft sprocket, a 19 tooth idler sprocket and a No. 60 chain make up the Thatcher Kit Drive Components.

1. Remove the lower belt guard (Figure 28) and the reel drive belt (Figure 29).
2. Remove the bolt and washer securing the jackshaft pulley to the jackshaft and remove the pulley (Figure 32).

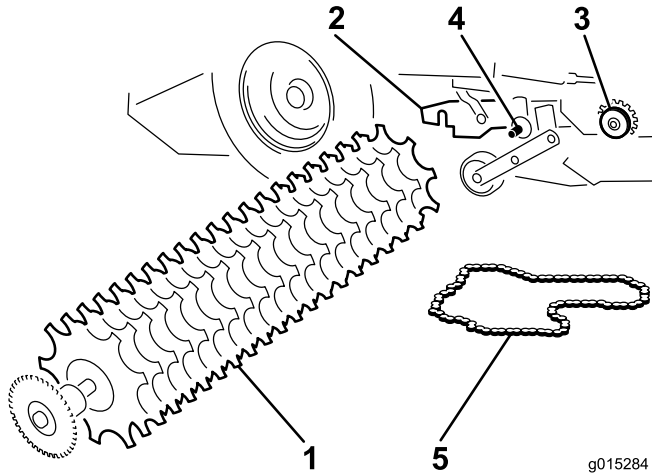

Figure 32

- | | |
|-----------------------|-------------------|
| 1. Thatcher reel | 4. Idler sprocket |
| 2. Reel support arm | 5. Chain |
| 3. Jackshaft sprocket | |

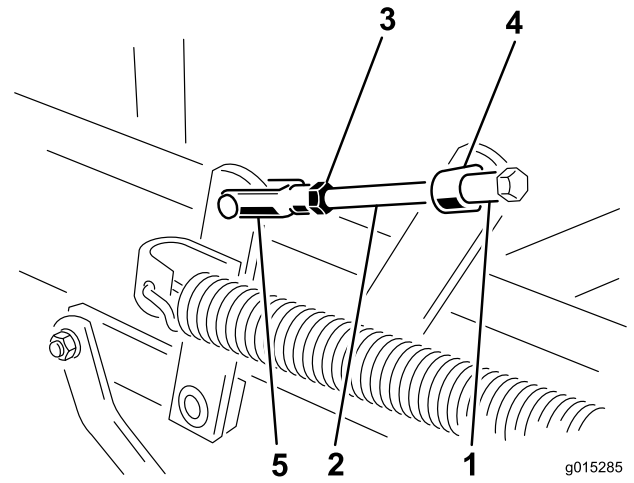

Figure 33

- | | |
|--------------------|----------------|
| 1. Spacer | 4. Pivot block |
| 2. Adjusting screw | 5. Clevis |
| 3. Jam nut | |

3. Slide the 16 tooth jackshaft sprocket onto the jackshaft.
4. Secure by tightening the 2 set screws and lock nuts on the sprocket hub.
5. Remove the idler pulley presently on the machine and replace it with the 19 tooth (#60) idler sprocket included in the kit.
6. Slide the thatcher into position and secure it to the reel support arms.
7. Align the idler sprocket with the jackshaft sprocket and thatcher sprocket.
8. Install the No. 60 chain, included in the kit. Lubricate with SAE 30 oil.
9. Push down on the idler sprocket until desired the chain tension is obtained.
10. Fasten the idler sprocket securely.

Note: Spacers mounted on the lift mechanism adjusting screws must be removed when the thatcher is installed on the machine (Figure 33).

11. Put the reel support arms in a lowered position.
12. Remove the jam nut and adjusting screw. Slide the spacer off adjusting screw.
13. Reassemble the jam nut and adjusting screw with the spacer positioned on the adjusting screw between the pivot block and clevis. This is the storage position for the spacer during thatcher operation.
14. Repeat the procedure on other side of the sweeper.

Note: Spacers should be re-installed whenever the thatcher is removed and either the brush or the flex tip reel is mounted to the sweeper.

Flex Tip Rake Rod Or Finger Plate Replacement

1. Remove the bolt and locknut from one end of the reel (Figure 34).

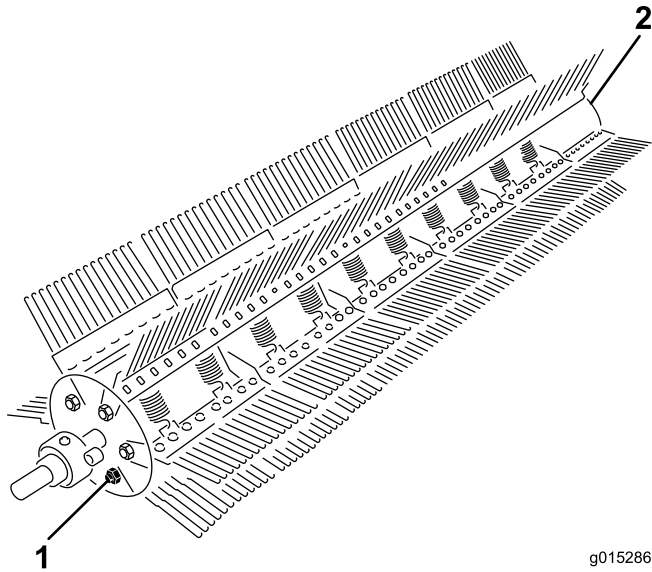

Figure 34

g015286

1. bolt and locknut
2. Locknut

2. Remove the locknut only from the opposite end of the reel.
3. Drive the rod from the end plate. Drive the rod from the end without the tab welded to it.
4. Remove the finger plates or rods as required and replace.
5. Line up the finger plate with the rod and drive the rod back through the end plate.
6. Attach the bolt, locknuts, and hook up the springs.

Flex Tip Rake Tine Replacement

1. Remove the tine retainer and slide the damaged tine out (Figure 35).

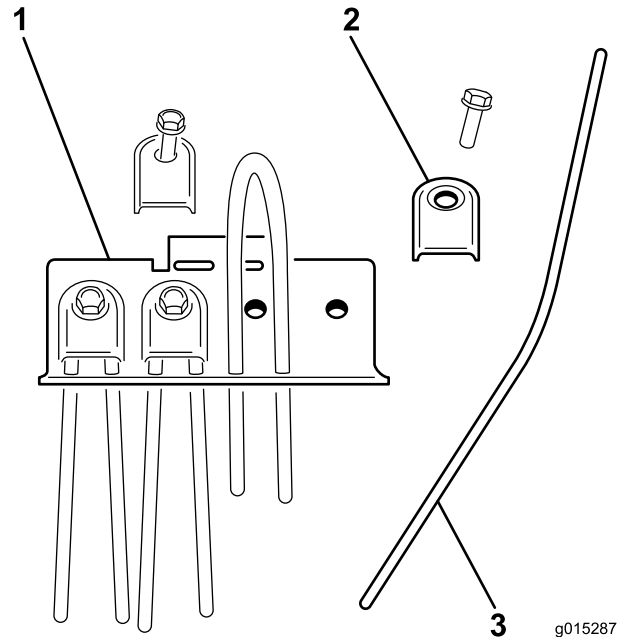

Figure 35

g015287

1. Finger plate
2. Tine retainer
3. Tine

2. Bend the new tine in half and slide it into position.
3. Place the tine bracket over the curved end of the tine and fasten it securely with the bolt and lockwasher.

Brush Half Replacement

1. Remove the brush from the sweeper.
2. Loosen the clamps with an allen wrench and remove it from the brush halves (Figure 36).

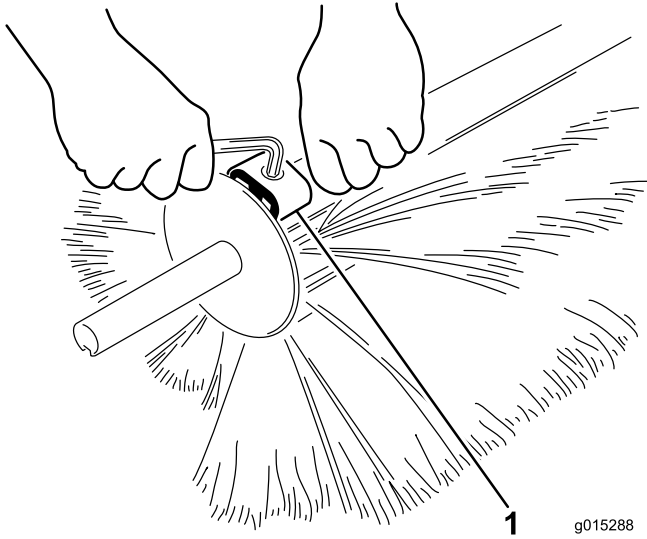

Figure 36

1. Clamp

3. Separate the brush halves and discard the damaged section(s) (Figure 37).

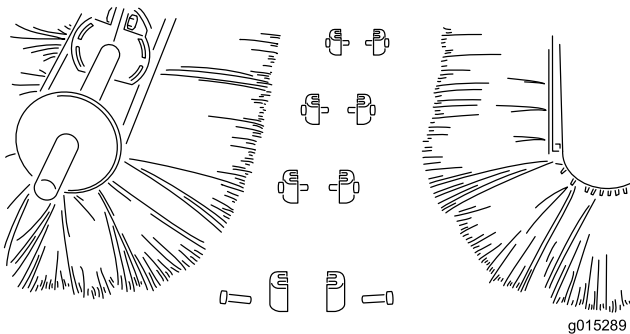

Figure 37

4. Install the new brush section by pushing them together and securing both ends with the brush clamps. When the ends have been secured, fasten the brush with the remaining clamps.

Cleaning

Cleaning the Blower Housing

⚠ WARNING

Before removing any debris from blower housing, disengage P.T.O. drive, stop engine(s) and make certain all moving parts have stopped or personal injury may occur.

1. Make sure the impeller has stopped rotating before removing the access plates.
2. Loosen the 2 wing nuts securing the access plate (Figure 38).

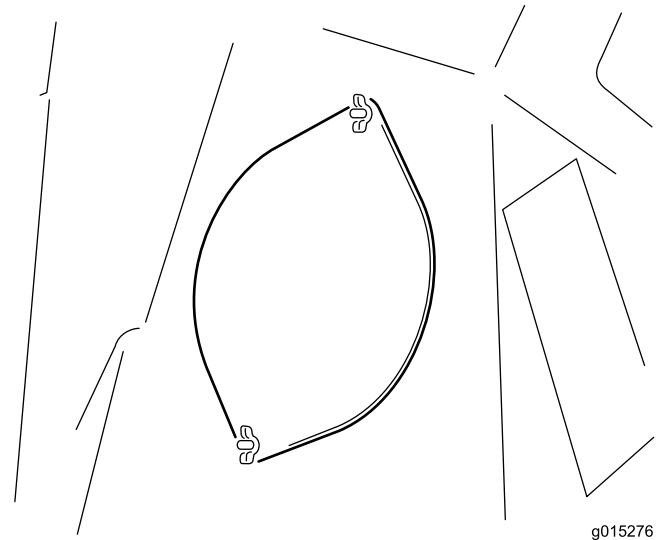

Figure 38
Access Plate

3. Swing the access plate to one side allowing the removal of debris.
4. After the debris has been removed, lower the access plate and secure with the wing nuts. Repeat the procedure on the other access plate.

Storage

1. Set the parking brake and turn the ignition key to off. Remove the spark plug wire and the key.
2. Remove grass, dirt, and grime from the external parts of the entire machine, especially the engine. Clean dirt and chaff from the outside of the engine's cylinder head fins and blower housing.
3. Service the air cleaner; refer to Servicing the Air Cleaner (page 19).
4. Change the crankcase oil; refer to Changing the Engine Oil and Filter (page 19).
5. Check the tire pressure; refer to Checking the Tire Pressure (page 23).
6. Check the condition of the tines.
7. If you will be storing the machine for more than 30 days, prepare it as follows:
 - A. Remove the battery terminals from the battery posts and remove the battery from the machine.
 - B. Clean the battery, terminals, and posts with a wire brush and baking soda solution.
 - C. Coat the cable terminals and battery posts with Grafo 112X skin-over grease (Toro Part No. 505-47) or petroleum jelly to prevent corrosion.
 - D. Slowly recharge the battery every 60 days for 24 hours to prevent lead sulfation of the battery. To prevent the battery from freezing, make sure it is fully charged. The specific gravity of a fully charged battery is 1.265 to 1.299.

⚠ WARNING

Charging the battery produces gasses that can explode.

Never smoke near the battery and keep sparks and flames away from it.

- E. Either store the battery on the shelf or on the machine. Leave the cables disconnected if it is stored on the machine. Store it in a cool atmosphere to avoid quick deterioration of the charge in the battery.
- F. Add a petroleum based stabilizer/conditioner to fuel in the tank. Follow mixing instructions from stabilizer manufacture. **Do not use an alcohol based stabilizer (ethanol or methanol).**

Note: A fuel stabilizer/conditioner is most effective when mixed with fresh gasoline and used at all times.

- G. Run the engine to distribute conditioned fuel through the fuel system (5 minutes).
- H. Stop the engine, allow it to cool and drain the fuel tank.
- I. Restart the engine and run it until it stops.
- J. Choke the engine. Start and run the engine until it will not start.
- K. Dispose of the fuel properly. Recycle as per local codes.

Important: Do not store stabilizer/conditioned gasoline over 90 days.

8. Remove the spark plugs and check the condition; refer to Servicing the Spark Plugs (page 20). With the spark plugs removed from the engine, pour two tablespoons of engine oil into each spark plug hole. Now use the starter to crank the engine and distribute the oil inside the cylinders. Install the spark plugs. Do not install the wires on the spark plugs.
9. Check and tighten all bolts, nuts, and screws. Repair or replace any part that is damaged or defective.
10. Wash and dry the entire unit. Remove the tines, clean and oil them. Spray light oil mist on the coring head bearings (crank & damper links).

Important: You can wash the machine with mild detergent and water. Do not pressure wash the machine. Avoid excessive use of water, especially near the control panel, engine, hydraulic pumps and motors.

Note: Run the machine with the engine at high idle for 2 to 5 minutes after washing.

11. Paint all scratched or bare metal surfaces. Paint is available from your Authorized Service Distributor.
12. Secure service latch if the aerator is to be stored for more than a couple days.
13. Store the machine in a clean, dry garage or storage area. Remove the key from the ignition switch and keep it out of reach of children or other unauthorized users.
14. Cover the machine to protect it and keep it clean.

Notes:



The Toro Total Coverage Guarantee

A Limited Warranty

Conditions and Products Covered

The Toro® Company and its affiliate, Toro Warranty Company, pursuant to an agreement between them, jointly warrant your Toro Commercial product ("Product") to be free from defects in materials or workmanship for two years or 1500 operational hours*, whichever occurs first. This warranty is applicable to all products with the exception of Aerators (refer to separate warranty statements for these products). Where a warrantable condition exists, we will repair the Product at no cost to you including diagnostics, labor, parts, and transportation. This warranty begins on the date the Product is delivered to the original retail purchaser.

* Product equipped with an hour meter.

Instructions for Obtaining Warranty Service

You are responsible for notifying the Commercial Products Distributor or Authorized Commercial Products Dealer from whom you purchased the Product as soon as you believe a warrantable condition exists. If you need help locating a Commercial Products Distributor or Authorized Dealer, or if you have questions regarding your warranty rights or responsibilities, you may contact us at:

Commercial Products Service Department
Toro Warranty Company
8111 Lyndale Avenue South
Bloomington, MN 55420-1196
E-mail: commercial.warranty@toro.com

Owner Responsibilities

As the Product owner, you are responsible for required maintenance and adjustments stated in your Operator's Manual. Failure to perform required maintenance and adjustments can be grounds for disallowing a warranty claim.

Items and Conditions Not Covered

Not all product failures or malfunctions that occur during the warranty period are defects in materials or workmanship. This warranty does not cover the following:

- Product failures which result from the use of non-Toro replacement parts, or from installation and use of add-on, or modified non-Toro branded accessories and products. A separate warranty may be provided by the manufacturer of these items.
- Product failures which result from failure to perform recommended maintenance and/or adjustments. Failure to properly maintain your Toro product per the Recommended Maintenance listed in the *Operator's Manual* can result in claims for warranty being denied.
- Product failures which result from operating the Product in an abusive, negligent or reckless manner.
- Parts subject to consumption through use unless found to be defective. Examples of parts which are consumed, or used up, during normal Product operation include, but are not limited to, brakes pads and linings, clutch linings, blades, reels, bed knives, tines, spark plugs, castor wheels, tires, filters, belts, and certain sprayer components such as diaphragms, nozzles, and check valves, etc.
- Failures caused by outside influence. Items considered to be outside influence include, but are not limited to, weather, storage practices, contamination, use of unapproved coolants, lubricants, additives, fertilizers, water, or chemicals, etc.

Countries Other than the United States or Canada

Customers who have purchased Toro products exported from the United States or Canada should contact their Toro Distributor (Dealer) to obtain guarantee policies for your country, province, or state. If for any reason you are dissatisfied with your Distributor's service or have difficulty obtaining guarantee information, contact the Toro importer. If all other remedies fail, you may contact us at Toro Warranty Company.

- Normal noise, vibration, wear and tear, and deterioration.
- Normal "wear and tear" includes, but is not limited to, damage to seats due to wear or abrasion, worn painted surfaces, scratched decals or windows, etc.

Parts

Parts scheduled for replacement as required maintenance are warranted for the period of time up to the scheduled replacement time for that part. Parts replaced under this warranty are covered for the duration of the original product warranty and become the property of Toro. Toro will make the final decision whether to repair any existing part or assembly or replace it. Toro may use remanufactured parts for warranty repairs.

Note Regarding Deep Cycle Battery Warranty:

Deep cycle batteries have a specified total number of kilowatt-hours they can deliver during their lifetime. Operating, recharging, and maintenance techniques can extend or reduce total battery life. As the batteries in this product are consumed, the amount of useful work between charging intervals will slowly decrease until the battery is completely worn out. Replacement of worn out batteries, due to normal consumption, is the responsibility of the product owner. Battery replacement may be required during the normal product warranty period at owner's expense.

Maintenance is at Owner's Expense

Engine tune-up, lubrication cleaning and polishing, replacement of Items and Conditions Not Covered filters, coolant, and completing Recommended Maintenance are some of the normal services Toro products require that are at the owner's expense.

General Conditions

Repair by an Authorized Toro Distributor or Dealer is your sole remedy under this warranty.

Neither The Toro Company nor Toro Warranty Company is liable for indirect, incidental or consequential damages in connection with the use of the Toro Products covered by this warranty, including any cost or expense of providing substitute equipment or service during reasonable periods of malfunction or non-use pending completion of repairs under this warranty. Except for the Emissions warranty referenced below, if applicable, there is no other express warranty.

All implied warranties of merchantability and fitness for use are limited to the duration of this express warranty. Some states do not allow exclusions of incidental or consequential damages, or limitations on how long an implied warranty lasts, so the above exclusions and limitations may not apply to you.

This warranty gives you specific legal rights, and you may also have other rights which vary from state to state.

Note regarding engine warranty:

The Emissions Control System on your Product may be covered by a separate warranty meeting requirements established by the U.S. Environmental Protection Agency (EPA) and/or the California Air Resources Board (CARB). The hour limitations set forth above do not apply to the Emissions Control System Warranty. Refer to the Engine Emission Control Warranty Statement printed in your *Operator's Manual* or contained in the engine manufacturer's documentation for details