



Electric Bed Lift Kit

2011 and After Workman® MDE Utility Vehicle

Model No. 07382—Serial No. 311000001 and Up

Addendum

Connecting the Electric Lift to the Upper Lift Bracket

The following procedures have been amended for use on all mid duty vehicles. These procedures supersede the corresponding ones within your *Installation Instructions*. Keep this document with the original *Installation Instructions*.

1. Press the switch upward to extend the actuator rod until it aligns with the upper lift bracket.
2. Locate the two sets of holes in the upper lift bracket (Figure 1).

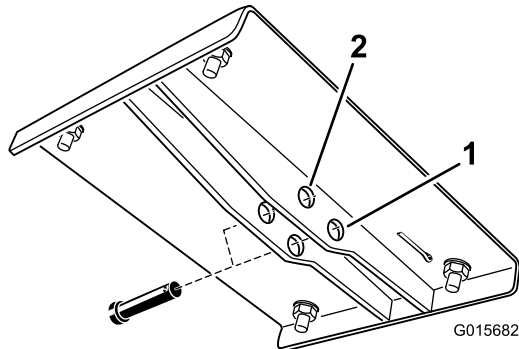

Figure 1

1. Hole for gasoline powered vehicles 2. Hole for electric vehicles

- For gasoline powered vehicles, select the set of holes in the bracket as depicted in Figure 1.
 - For electric vehicles, select the alternate set of holes in the bracket as depicted in Figure 1.
3. Secure the rod to the bracket with the large clevis pin and cotter pin.