



Belt Guard Kit

TimeCutter® ZS 5000 Riding Mower

Model No. 120-7790

Installation Instructions

Do not supply these instructions to the customer.

These instructions are for a dealer to install additional belt guards on units sold in France.

Safety

Safety and Instructional Decals



Safety decals and instructions are easily visible to the operator and are located near any area of potential danger. Replace any decal that is damaged or lost.



120-1119

1. Fire hazard—read the *Operator's Manual*.

Installation

1

Preparing for Installation

No Parts Required

Procedure

Important: Refer to the *Operator's Manual* if you are unfamiliar with the specifics of operating this machine before proceeding. The manual contains important information about safely operating the machine. If you do not know this information, you could seriously injure yourself or others.

1. Park the machine on a level, smooth surface with sufficient space to access both sides of the mowing deck.

▲ WARNING

Before working on the machine, stop the engine, set the parking brake, remove the ignition key, and disconnect the spark plug wire.

▲ CAUTION

If you leave the key in the ignition switch, someone could accidentally start the engine and seriously injure you or other bystanders.

Remove the key from the ignition and disconnect the wire from the spark plug before you do any maintenance. Set the wire aside so that it does not accidentally contact the spark plug.

2. Check the loose parts bag and verify that it contains all the parts listed in this document.
3. Remove the mowing deck and slide it out from under the traction unit; refer to the *Operator's Manual* for this model.

2

Assembling the Deck Belt Guard

Parts needed for this procedure:

1	Left deck guard plate
1	Right deck guard plate
1	Top deck guard plate
4	Hex Bolt (M6-1X16)
4	Locknut (NIM6-1)

Procedure

Assemble the left, right and top deck guard plates using 4 hex bolts and 4 locknuts as shown in Figure 1.

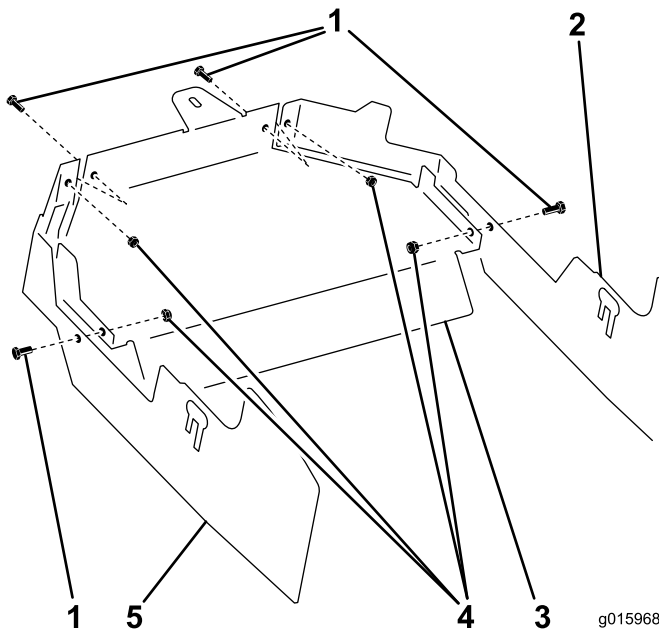

Figure 1

- 1. Hex Bolt (M6-1X16) (4)
- 2. Left deck guard plate
- 3. Top deck guard plate
- 4. Locknut (NIM6-1) (4)
- 5. Right deck guard plate

3

Installing the Deck Belt Guard

No Parts Required

Procedure

1. Loosen, **but do not remove**, the flange nut on the outside of each suspension bracket on the rear of the deck; see Figure 2.

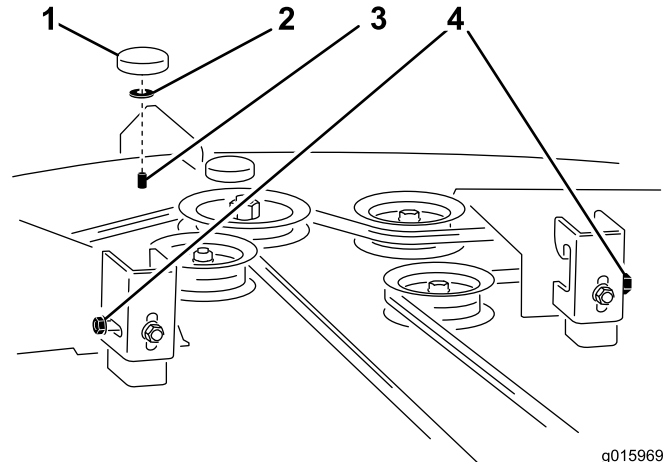

g015969

Figure 2

- 1. Knob, existing
 - 2. Washer, existing
 - 3. Bolt, existing
 - 4. Flange nuts
2. Remove the knob, washer and bolt shown in Figure 2 and set them aside.
 3. Mount the assembled deck belt guard onto the deck.
 - A. Attach the tab at the front of the guard to the deck using the existing bolt, washer and knob that you just set aside; see Figure 3.

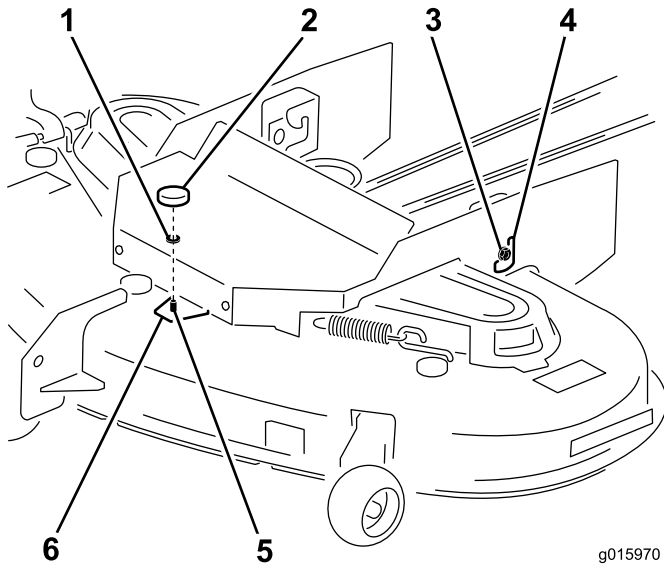

Figure 3

- | | |
|-----------------------------|-------------------------|
| 1. Washer, existing | 4. Rear slots, pair (2) |
| 2. Knob, existing | 5. Bolt, existing |
| 3. Flange nut, existing (2) | 6. Tab |

B. For each side of the guard, insert the previously loosened flange nut through the large opening and slide the bolt into the slot that fits best (Figure 3).

C. Tighten both flange nuts and the knob securely.

4. Verify that the guard is clear of all moving parts across their full range of operation, that it will not cause damage to wires, hoses or other components and that it will not interfere with the safe operation of the cutting deck.

4

Attaching the Deck

No Parts Required

Procedure

1. Slide the deck back under the machine, mount it to the traction unit and adjust it as described in the *Operator's Manual* for this model.
2. Verify that the belt guards are clear of all moving parts across their full range of operation, that they will not cause damage to wires, hoses or other components and that they will not interfere with the safe operation of the mowing deck and the traction unit.



Count on it.