



Count on it.

Parts Catalog

**Z580-D Z Master[®], With 132cm
TURBO FORCE[®] Side Discharge
Mower**

Model No. 74264TE—Serial No. 311000001 and Up

Ordering Replacement Parts

To order replacement parts, please supply the part number, the quantity, and the description of each part desired.

Understanding Reference Numbers

Each identified part in an illustration has a reference number. The reference number for a part also appears in the parts list, along with other information about the part.

This catalog uses two special reference number formats, one to indicate parts in a service assembly and another to indicate the quantity of a given part in an illustration.

Service Assembly Reference Numbers

Parts in service assemblies have reference numbers in the form a:b. The a represents the reference number of the entire service assembly and the b represents a sequential number unique to each part within the service assembly.

For example, a wheel assembly might be identified by reference number 6, the tire by 6:1, the valve by 6:2, and the wheel by 6:3. When you order the assembly identified by reference number 6, you receive all parts identified by reference numbers 6:1, 6:2, and 6:3. However, you may also order any part individually. Reference numbers of this type appear in illustration and in parts lists.

Reference Numbers Indicating Quantity

In an illustration, if a reference number indicates more than one part, the reference number has the form nX y. The n represents the quantity of the part, the X is the multiplication symbol, and the y represents the reference number.

For example, in an illustration, the reference number 2X 37 means that two of the parts identified by reference number 37 are indicated.

List of Abbreviations

AR: as required

ASM: assembly

BBC: blade brake control

BHTF: button head thread forming

CARR: carriage

CCW: counter clockwise

CW: clockwise

DEG: degrees

DPA: Dual Point Adjustment

ECM: electronic control module

EXT: external

FH: flat head

GA: gauge

HD: heavy-duty

HF: hex flange

HH: hex head

HHF: hex head flange

HHFTF: hex head flange thread forming

HJ: hex jam

HLH: hex lag head

HOC: height-of-cut

HSBH: hex socket button head

HSFH: hex socket flat head

HSH: hex socket head

HWH: hex washer head

HWTF: hex washer head thread forming

HYD: hydraulic

LH: left hand

LP: Liquid Propane

NI: nylon insert

NPTF: national pipe thread fine

PFH: phillips flat head

PPH: phillips pan head

PPHTF: phillips pan head thread forming

PRH: phillips round head

PTH: phillips truss head

PTO: power-take-off

RH: right hand

ROPS: roll-over protection system

RRB: rear roller brush

SFH: slotted fillister head

SHH: slotted hex head

SHWH: slotted hex washer head

SPH: slotted pan head

SQH: square head

SRH: slotted round head

STD: standard

TAP: self tapping

TTH: torx truss head

Contents

Front Frame Assembly	4
Fork, Caster Wheel and Z Stand Assembly	5
Traction Frame and Floor Pan Assembly	6
Seat and Roll-Over Protection System Assembly	7
Deluxe Seat Assembly No. 110-0838	8
Roll-Over Protection System Assembly No. 110-0877	9
Main Frame and Rear Wheel Assembly	10
Hydro Control Assembly	11
Engine, Exhaust and Air Intake Assembly	12
Air Cleaner Assembly No. 93-2190	13
Hydro and Gearbox Assembly	14
Gearbox Assembly No. 107-9887	15
Hydraulic Tank, Motor and Pump Assembly	16
Tandem Pump Assembly No. 107-9885	18
Hydraulic Motor Assembly No. 112-8357 (CCW)	19
Hydraulic Motor Assembly No. 112-8358 (CW)	20
Hydraulic Hose System Assembly	21
Fuel System and Throttle Control Assembly	22
Fuel Line Assembly	23
Engine Housing Assembly	24
Cooling System Assembly	25
Hood Assembly	26
Deck Connection Assembly	27
Deck Assembly	28
Spindle Assembly No. 117-6159	30
Deck Decal Assembly No. 114-4487	31
Rubber Deflector Assembly No. 108-2792	32
Lever Assembly No. 107-1664	33
Electrical Assembly	34
Attachments and Accessories	35

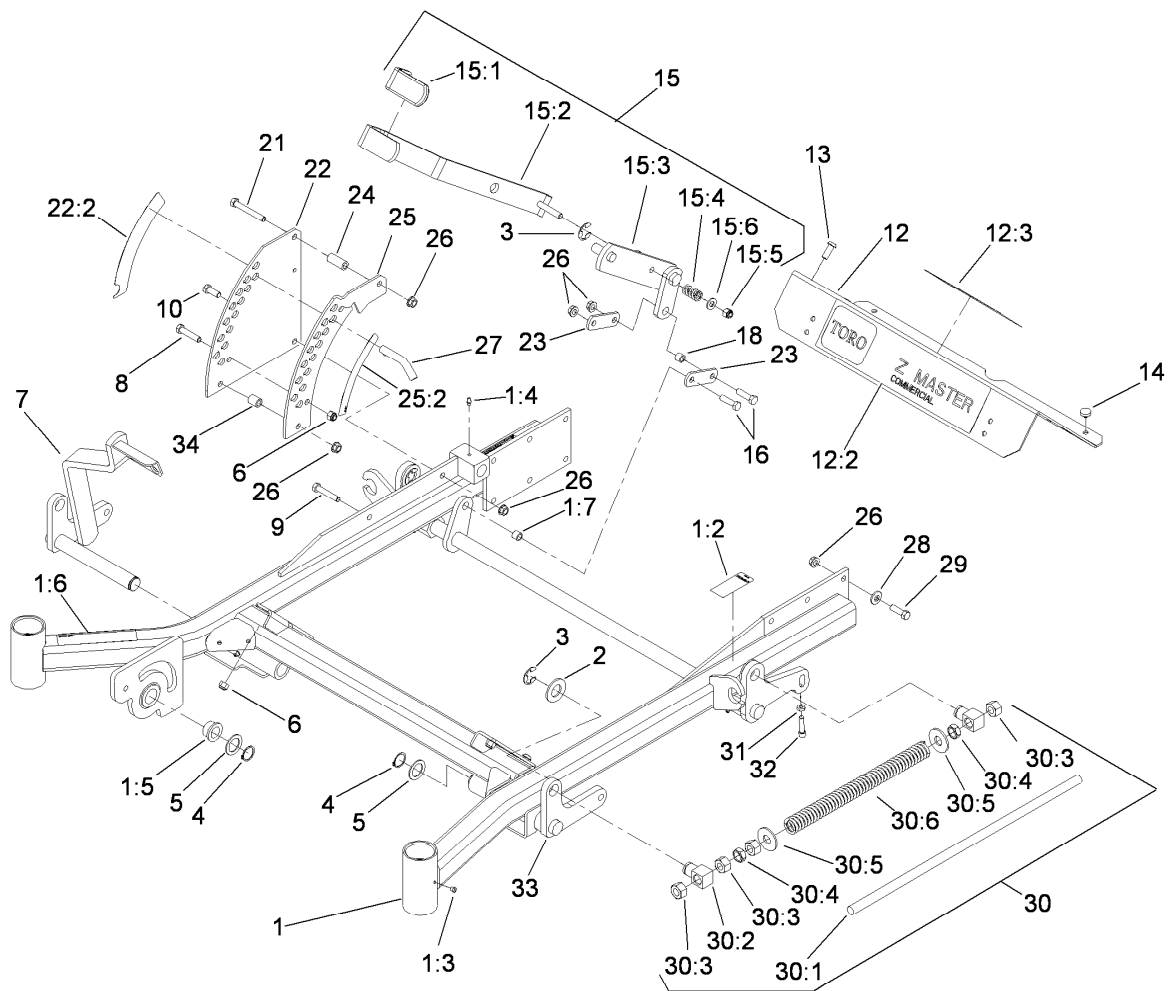

Front Frame Assembly

Ref.	Part Number	Qty.	Description	Ref.	Part Number	Qty.	Description
1	110-0800	1	Frame ASM	15:5	3296-39	1	Nut-Lock, NI
1:2	107-3968	1	Decal-Brake, Parking	15:6	3256-24	1	Washer-Flat
1:3	1-811010	2	Plug	16	323-29	2	Screw-HH
1:4	302-19	5	Fitting-Grease	18	103-1918	1	Bushing
1:5	94-1291	2	Bushing	21	323-11	1	Screw-HH
1:6	107-3969	1	Decal-Warning	22	117-0367	1	Plate-HOC, Outer
1:7	103-1918	1	Bushing	22:2	107-3961	1	Decal-Height, Deck
2	3256-29	4	Washer-Flat	23	1-633068	2	Arm-Lift, Deck
3	32151-103	5	Ring-Retaining, EXT	24	1-633082	1	Bushing-Lever, Lift
4	32151-29	2	Ring-Retaining	25	117-0370	1	Plate-HOC, Inner
5	1-523157	2	Washer-Spacer	25:2	107-3962	1	Decal-Height, Deck
6	3296-39	5	Nut-Lock, NI	26	3290-357	17	Nut-HHF, Whiz
7	108-7786-01	1	RH Front Deck Lift ASM	27	109-8757	1	Pin-HOC
8	323-9	1	Screw-HH	28	98-5975	12	Washer-Belleville
9	323-10	1	Screw-HH	29	323-7	12	Screw-HH
10	323-6	1	Screw-HH	30		2	Front Frame Spring ASM ●
12	107-3976	1	Footrest	30:1	1-633096	1	Rod-Lift, Deck
12:2	106-7451	1	Decal	30:2	1-633441	2	Swivel-Deck Mount, Rear
12:3	107-1866	1	Decal-Danger, Slope	30:3	3217-11	4	Nut-Hex
13	3274-94	4	Screw-HSBH	30:4	3218-6	2	Nut-Jam
14	1-513658	2	Bumper	30:5	3256-7	2	Washer-Flat
15	110-5860	1	Deck Lift Handle ASM	30:6	1-633064	1	Spring-Support, Deck
15:1	1-633295	1	Grip-Lever, Lift	31	3218-2	2	Nut-Jam
15:2	103-2083	1	Lever-Lift	32	3274-18	2	Screw-HSH
15:3	103-2064	1	Arm-Lift, Deck	33	106-8984-01	1	LH Deck Lift ASM
15:4	1-633325	1	Spring-Compression	34	1-633080	1	Bushing-Lever, Lift

● Not serviced separately

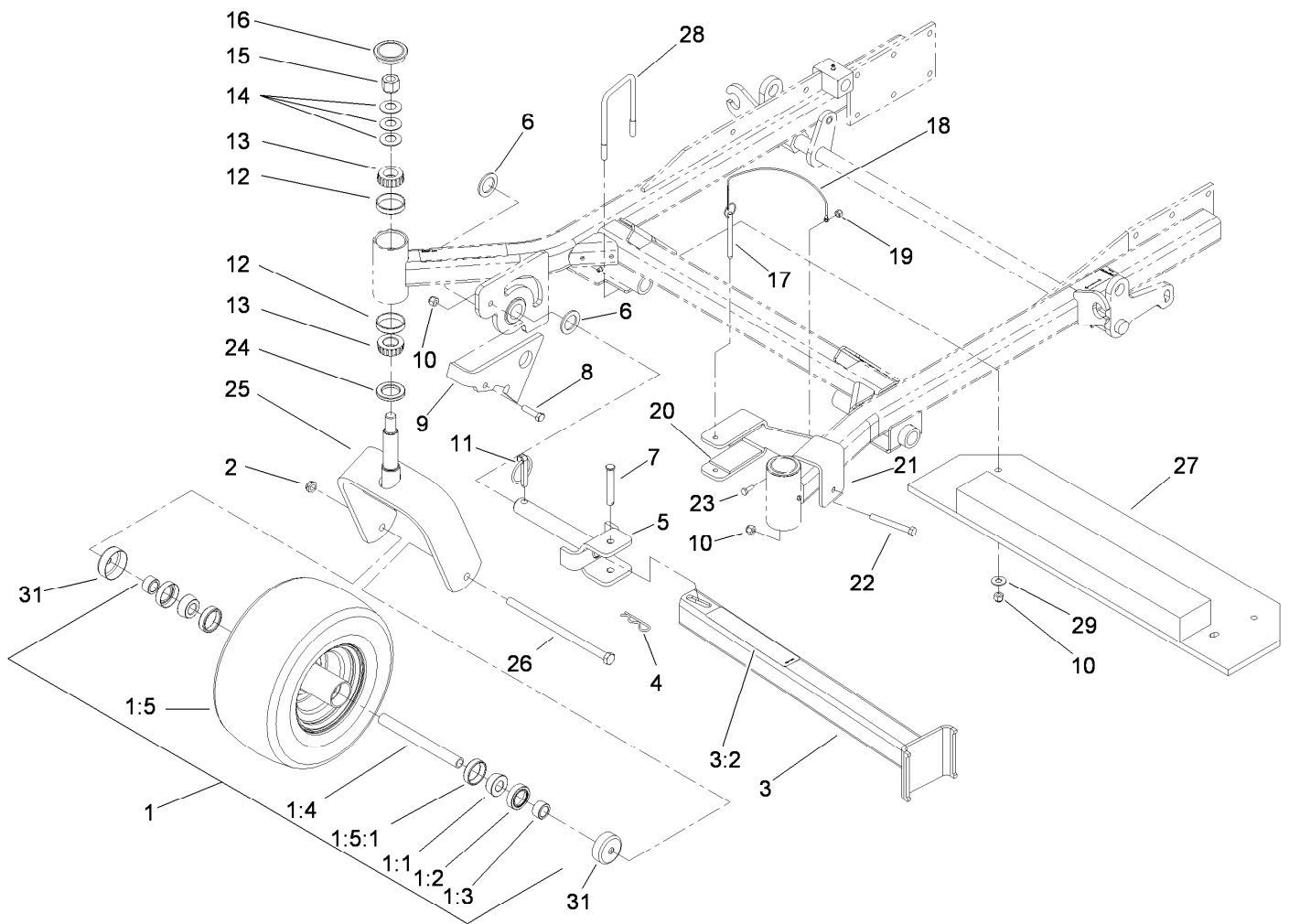

Fork, Caster Wheel and Z Stand Assembly

Ref.	Part Number	Qty.	Description	Ref.	Part Number	Qty.	Description
1	109-9125	2	Wheel And Tire ASM	13	254-94	4	Bearing-Cone, Tapered
1:1	1-633585	2	Bearing-Cone, Taper	14	1-633508	6	Washer-Bellville
1:2	103-0063	2	Seal-Caster	15	3296-51	2	Nut-Lock, NI
1:3	103-3051	2	Spacer-Nut	16	103-4882	2	Cap-Grease
1:4	103-5156	1	Axle-Caster	17	105-1647	1	Pin-Hitch, Cotterless
1:5	109-9124	1	Wheel And Tire ASM	18	100-9385	1	Lanyard-Nylon
1:5:1	1-633584	1	Bearing-Cup	19	3296-42	1	Nut-Lock, NI
2	3296-23	2	Nut-Lock, NI	20	100-6547	2	Cushion-Rubber
3	107-1874	1	Leg ASM	21	100-6542-01	1	Bracket-Cradle
3:2	106-7464	1	Decal-Z Stand	22	323-20	1	Screw-HH
4	3290-355	1	Pin-Hair	23	321-4	1	Screw-HH
5	100-9692-01	1	Pivot Pin ASM	24	1-543511	2	Seal-Grease
6	3-6781	2	Washer-Thrust	25	1-642111-01	2	Caster
7	283-55	1	Pin-Clevis	26	325-24	2	Screw-HH
8	323-8	1	Screw-HH	27	107-9874-01	1	Weight ASM
9	100-9686-01	1	Bracket-Latch	28	110-0817	2	U-Bolt, 3 Inch
10	3296-39	6	Nut-Lock, NI	29	3256-4	4	Washer-Flat
11	283-71	1	Pin-Lynch	31	103-2768	4	Guard-Seal
12	254-72	4	Bearing-Cup, Tapered				

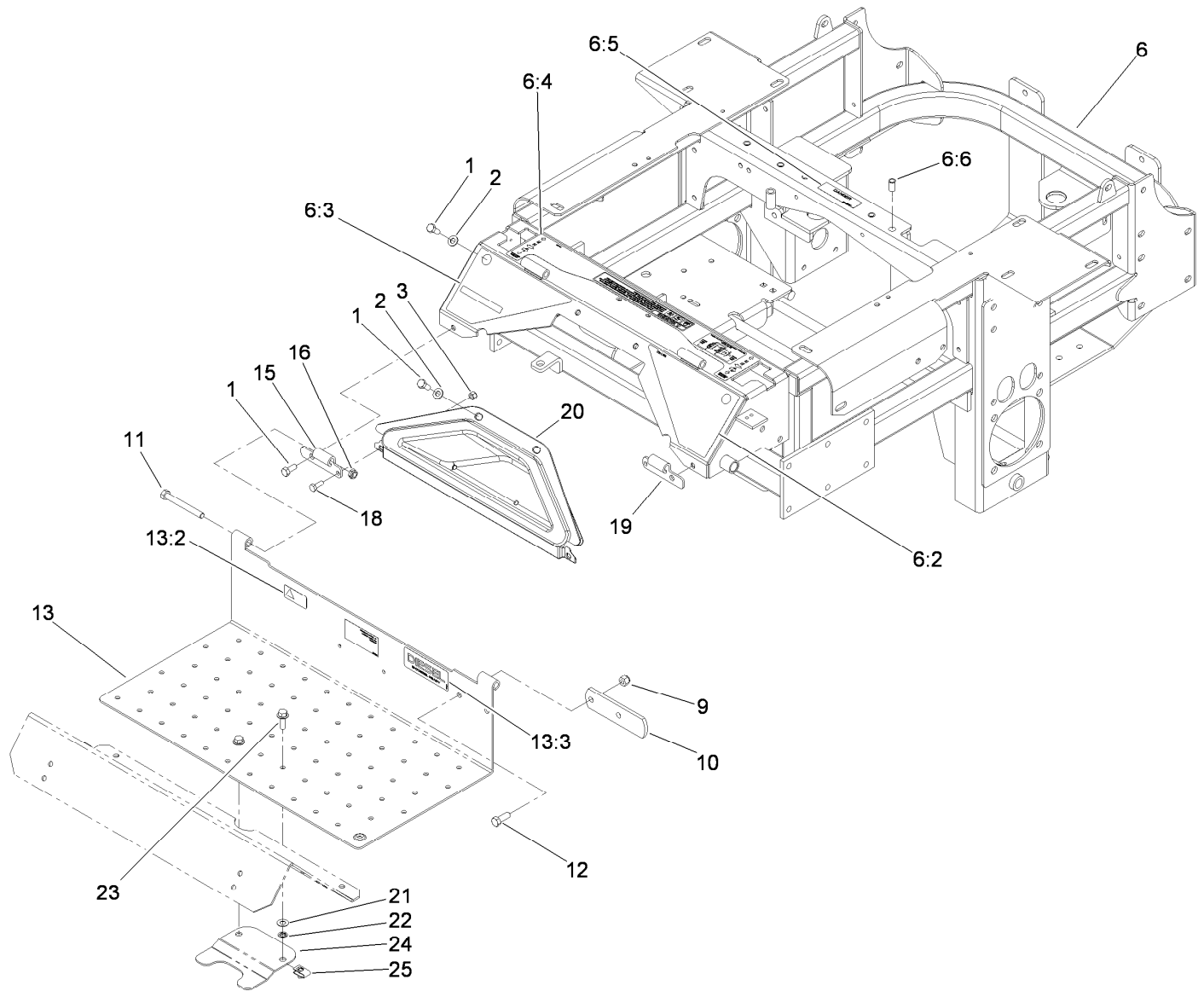

Traction Frame and Floor Pan Assembly

Ref.	Part Number	Qty.	Description	Ref.	Part Number	Qty.	Description
1	322-43	6	Screw-HH	13	115-3851	1	Floor Pan ASM
2	3256-70	4	Washer-Flat	13:2	98-4387	1	Decal-Protection, Ear
3	3296-42	2	Nut-Lock, NI	13:3	114-5879	1	Decal-Diesel, Bio-Ready
6	115-2757	1	Traction Frame ASM	15	106-7488-03	1	Hinge-Floorpan, LH
6:2	107-3963	1	Decal-Danger, Left	16	3296-59	2	Nut-Lock, NI
6:3	107-3964	1	Decal-Warning, Right	18	321-4	2	Screw-HH
6:4	110-0820	1	Decal-Console, Top (Ce)	19	106-7489-03	1	Hinge-Floorpan, RH
6:5	98-1977	1	Decal-Warning	20	106-7498	1	Pocket
6:6	32148-11	5	Insert-Threaded	21	73-0041	2	Washer-Thrust
9	3296-39	2	Nut-Lock, NI	22	117-2749	2	Nut-Push
10	1-633964-03	1	Stop-Brake, Park	23	3234-29	2	Screw-HHF
11	323-20	2	Screw-HH	24	119-0395-03	1	Adapter-Captive
12	323-6	2	Screw-HH	25	94-2413	2	U-Nut

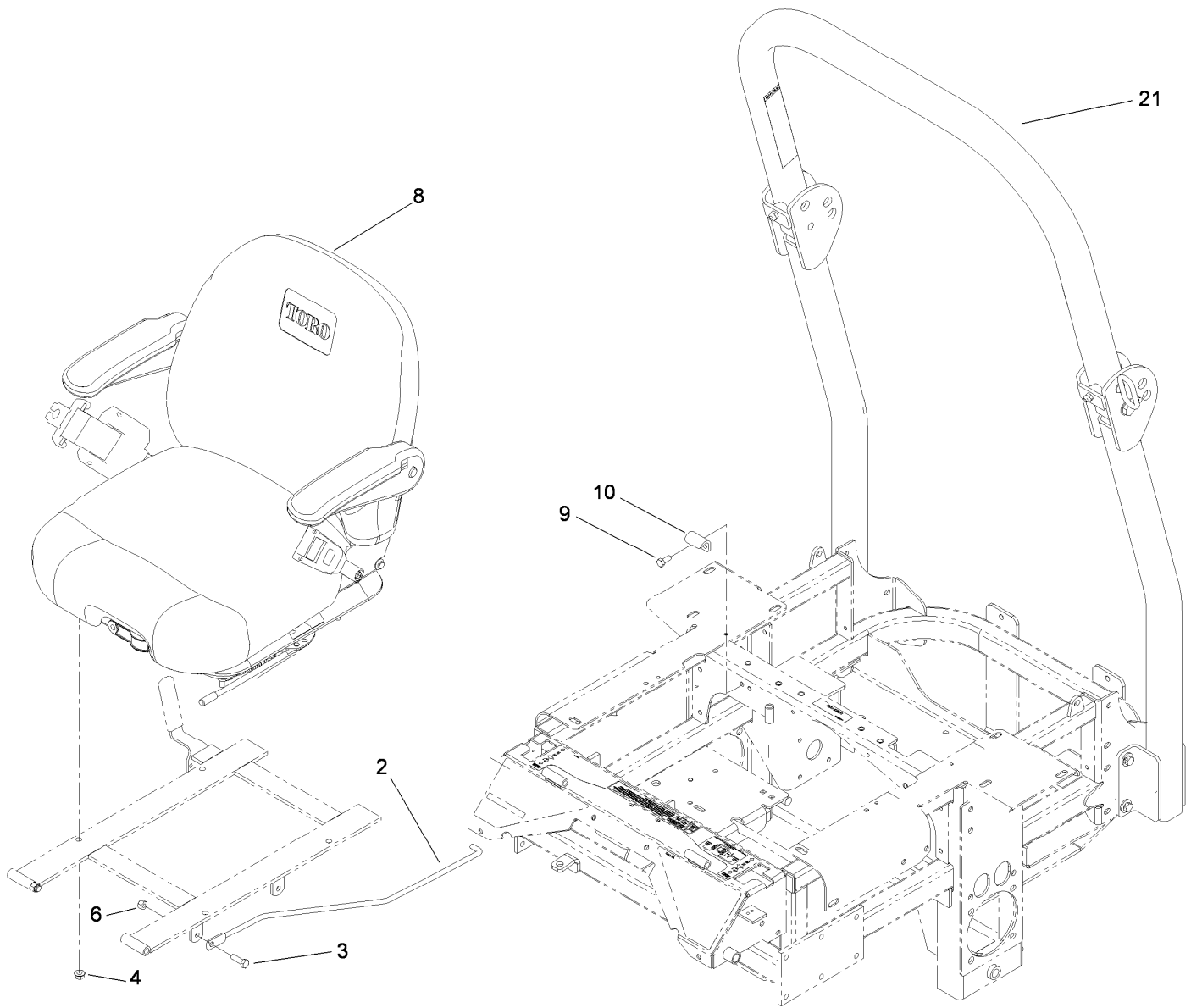

Seat and Roll-Over Protection System Assembly

<i>Ref.</i>	<i>Part Number</i>	<i>Qty.</i>	<i>Description</i>
2	108-5341	1	Rod-Prop, Seat
3	322-5	1	Screw-HH
4	32128-20	4	Nut-HF
6	3296-29	3	Nut-Lock, NI
8	110-0838	1	Deluxe Seat ASM
9	322-3	2	Screw-HH
10	107-3058	1	Catch-Latch, Seat
21	110-0877	1	ROPS Kit

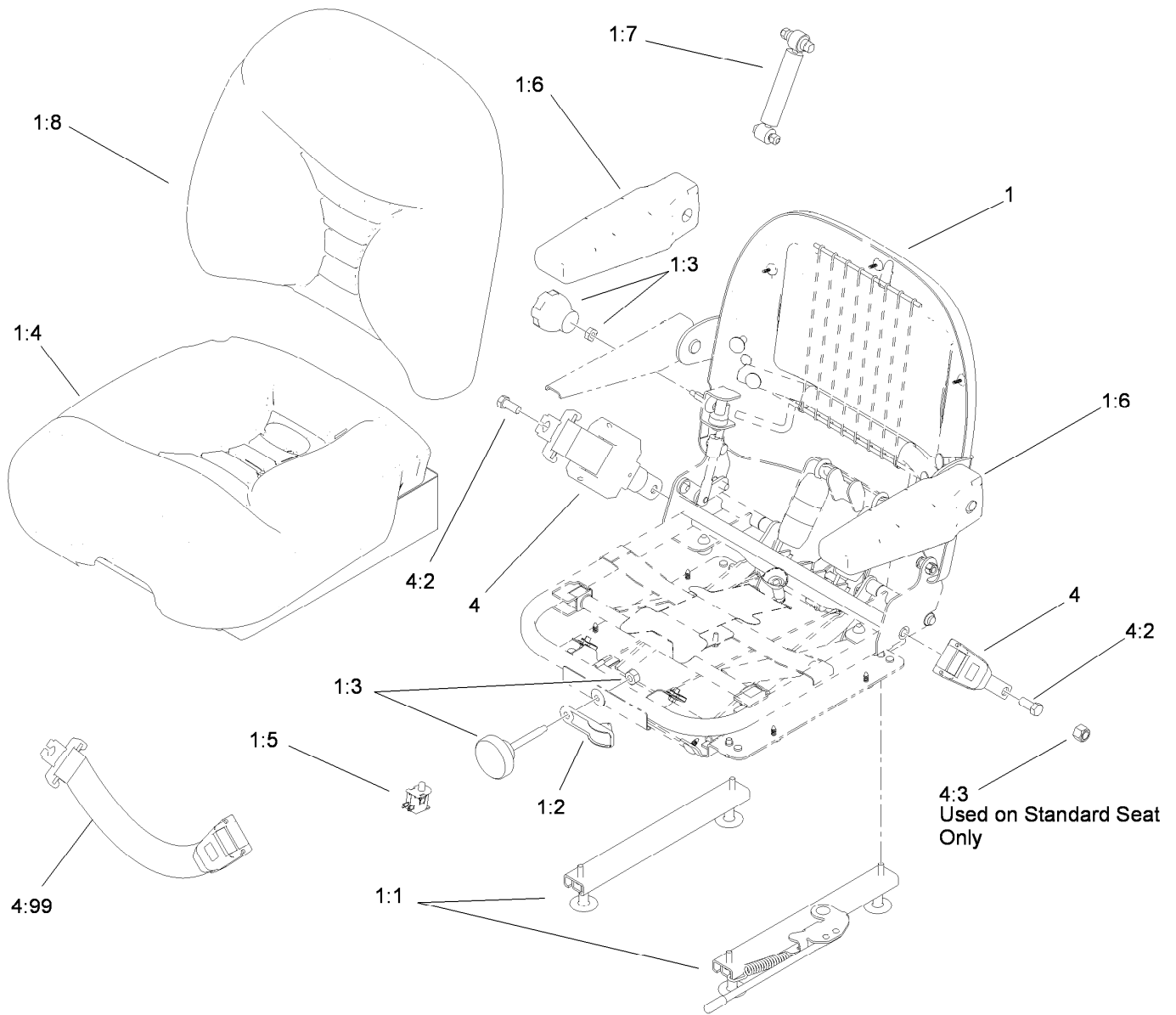

Deluxe Seat Assembly No. 110-0838

Ref.	Part Number	Qty.	Description
1	112-8355	1	Seat-Suspension
1:1	107-1880	1	Seat Track Kit
1:2	107-1885	1	Weight Indicator Kit
1:3	107-1881	1	Knob Kit
1:4	107-1883	1	Bottom Cushion Kit
1:5	82-2190	1	Switch-Bail
1:6	107-1887	1	Armrest Kit
1:7	107-1884	1	Shock Absorber Kit
1:8	112-8356	1	Cushion-Back
4	110-0883	1	Retractable Seatbelt Kit
4:2	3212-4	2	Screw-HH
4:3	3296-7	2	Nut-Lock
4:99	109-6226	1	Seat Belt Extension Kit

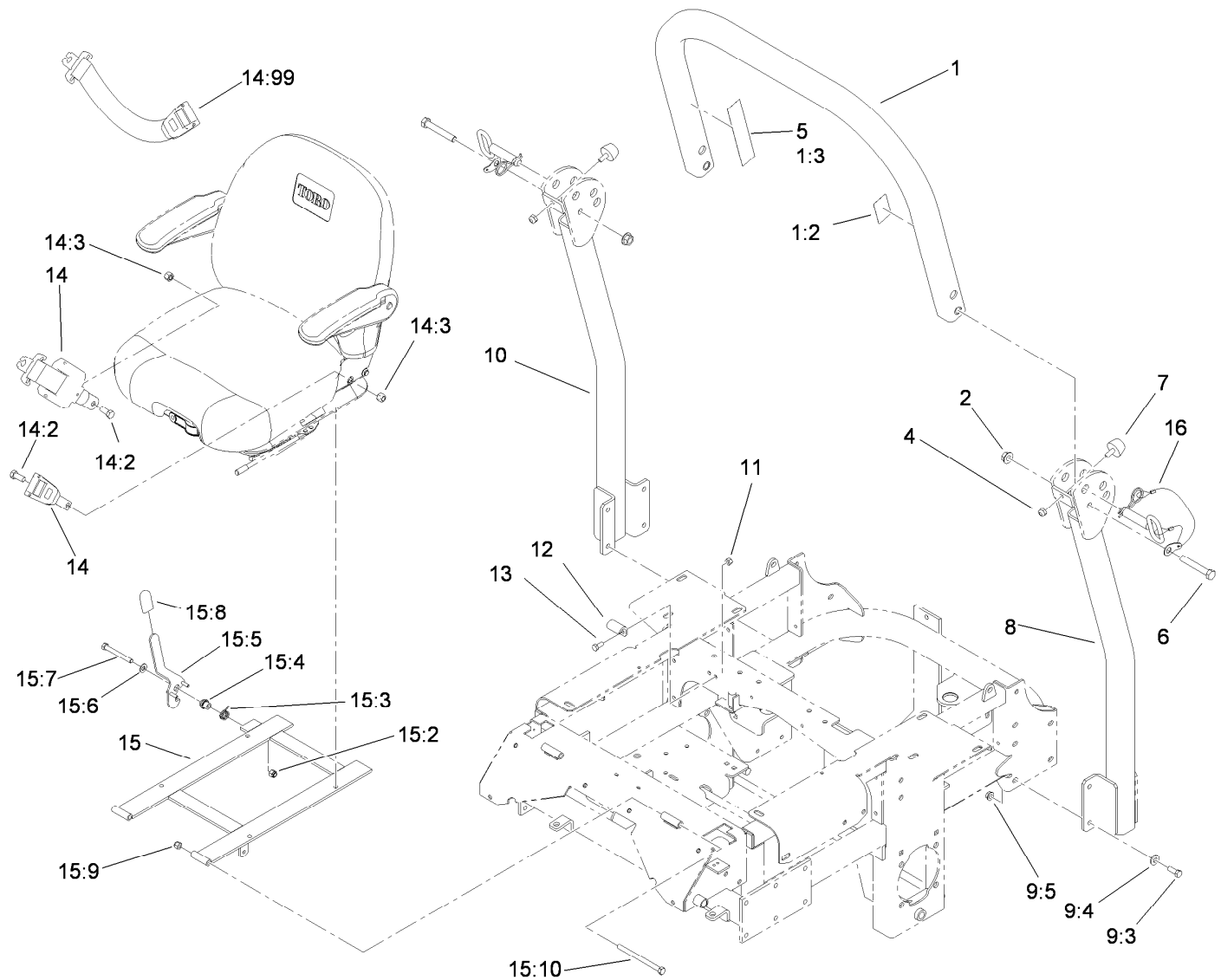

Roll-Over Protection System Assembly No. 110-0877

Ref.	Part Number	Qty.	Description	Ref.	Part Number	Qty.	Description
1		1	Upper Tube ASM ■	12	107-3058	1	Catch-Latch, Seat
1:2	107-2101	1	Decal-ROPS	13	322-3	2	Screw-HH
1:3	107-2102	1	Decal-Warning, Folding ROPS	14	110-0883	1	Retractable Seatbelt Kit
2	32128-23	2	Nut-HF	14:2	3212-4	2	Screw-HH
4	3296-73	2	Nut-Lock, NI	14:3	3296-7	2	Nut-Lock
5	107-3069	1	Decal-Warning, Folding ROPS	14:99	109-6226	1	Seat Belt Extension Kit
6	325-13	2	Screw-HH	15	110-0874	1	Seatframe ASM
7	109-2365	2	Rubber Bumper ASM (W/Stud)	15:2	3296-39	1	Nut-Lock, NI
8		1	Tube-Support, LH ■	15:3	107-0076	1	Spring-Torsion
9		1	Bag-Bolt, ROPS ● ■	15:4	107-0075	1	Bushing-Latch, Seat
9:3	323-6	8	Screw-HH	15:5	107-3083	1	Latch ASM
9:4	98-5975	8	Washer-Belleville	15:6	3256-24	1	Washer-Flat
9:5	3290-357	8	Nut-HHF, Whiz	15:7	323-20	1	Screw-HH
10		1	Tube-Support, RH ■	15:8	103-4434	1	Grip-Lever
11	3296-29	2	Nut-Lock, NI	15:9	3296-39	2	Nut-Lock, NI
				15:10	323-39	2	Screw-HH
				16	103-4553	2	ROPS Fold Pin ASM

● Not illustrated

■ Not serviced separately

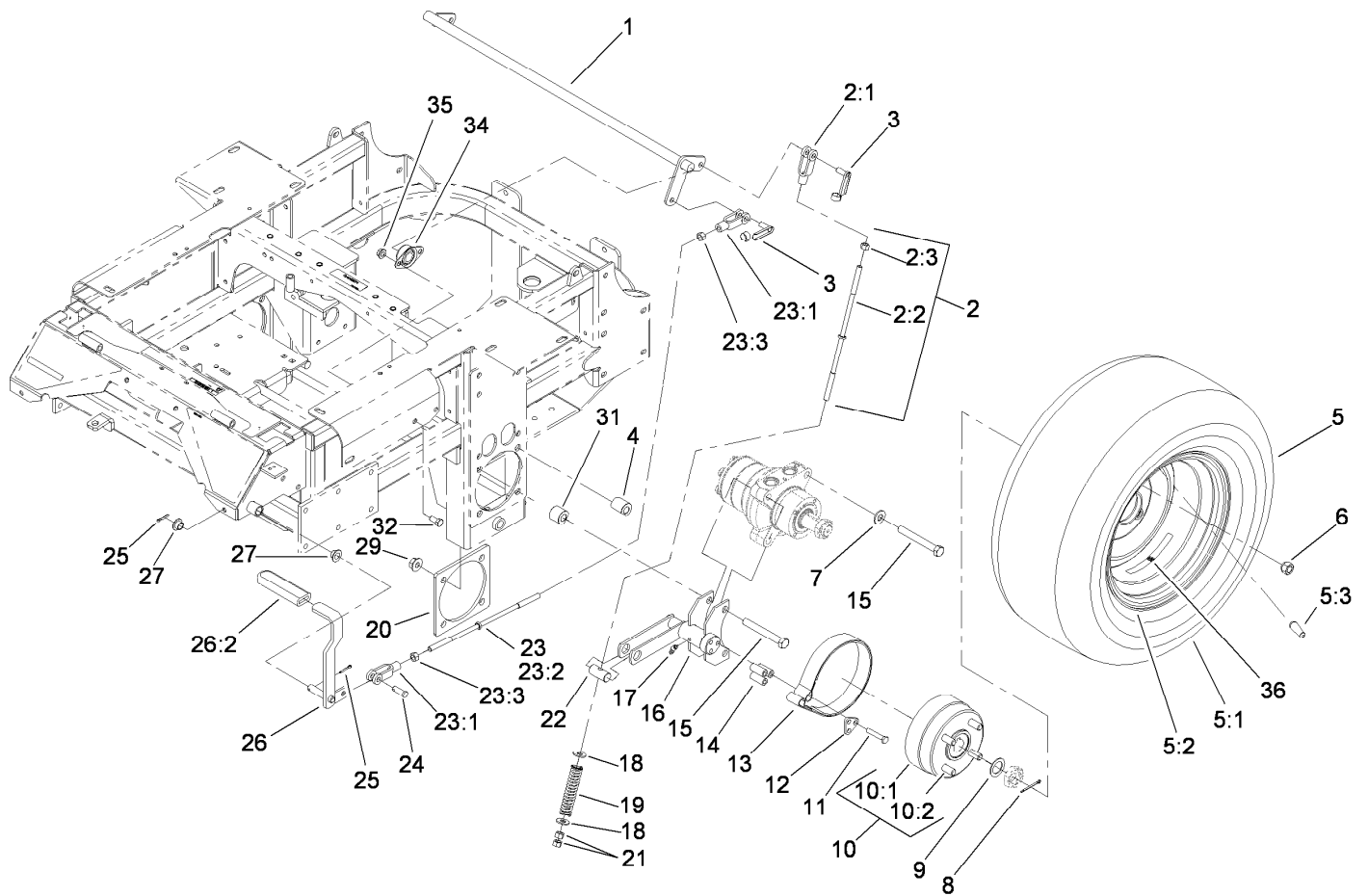

Main Frame and Rear Wheel Assembly

Ref.	Part Number	Qty.	Description	Ref.	Part Number	Qty.	Description
1	1-632217-03	1	Shaft-Brake	16	103-0352-03	2	Bracket-Brake
2	108-5963	2	Brake Rod ASM	17	1481	2	Fitting-Grease
2:1	1-633131	1	Yoke-Linkage, Brake	18	3256-4	4	Washer-Flat
2:2	108-5980	1	Rod-Brake	19	1-633454	2	Spring-Brake
2:3	3219-3	1	Nut-Hex	20	103-3271-03	2	Plate-Reinforcement
3	103-2399	3	Pin-Spring, Clevis	21	3219-3	4	Nut-Hex
4	114-1185	4	Spacer-Wheel, Long	22	1-633144	2	Pin-Trunion
5	1-653010	2	Wheel And Tire ASM	23	108-5962	1	Brake Rod ASM
5:1	1-653160	1	Tire	23:1	1-633131	2	Yoke-Linkage, Brake
5:2	1-653158	1	Wheel	23:2	1-633477	1	Rod-Brake
5:3	232-27	1	Stem-Valve	23:3	3219-3	2	Nut-Hex
6	242-50	8	Nut-Lug	24	1-808285	1	Pin-Clevis
7	87-7270	4	Washer-Thrust	25	3272-10	2	Pin-Cotter
8	1-806800	2	Pin-Cotter	26	1-634500	1	Brake Lever ASM
9	1-523157	2	Washer-Spacer	26:2	1-633268	1	Grip-Lever
10	103-0590	2	Hub And Wheel ASM	27	1-513140	2	Bearing-Control
10:1	103-0589	1	Wheel Hub ASM	29	32128-49	8	Nut-HHF
10:2	1-633926	4	Stud-Wheel	31	114-1184	4	Spacer-Wheel, Short
11	322-9	6	Screw-HH	32	323-4	4	Screw-HH
12	103-0374	2	Retainer-Band, Brake	34	1-633102	2	Bearing-Flange, Side
13	103-0355	2	Band-Brake	35	3290-357	4	Nut-HHF, Whiz
14	103-0384	6	Spacer	36	109-7949	2	Decal
15	325-18	8	Screw-HH				

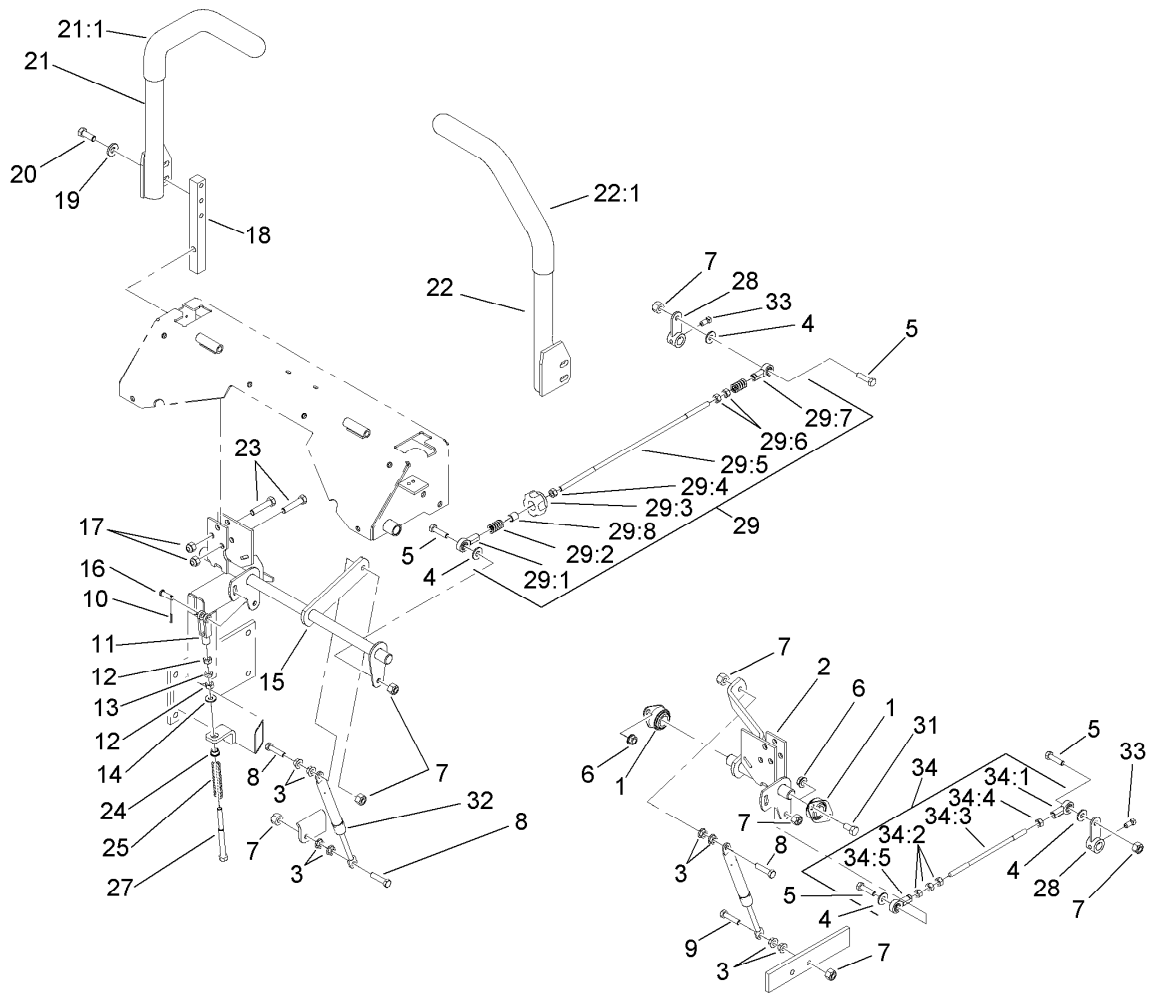

Hydro Control Assembly

Ref.	Part Number	Qty.	Description
1	1-633102	4	Bearing-Flange, Side
2	107-3480	1	LH Motion Control ASM
3	32128-20	10	Nut-HF
4	3256-3	4	Washer-Flat
5	322-6	4	Screw-HH
6	3290-357	6	Nut-HHF, Whiz
7	3296-29	8	Nut-Lock, NI
8	1-403180	3	Screw-HH
9	322-41	1	Screw-HH
10	3272-5	2	Pin-Cotter
11	1-303105	2	Yoke-Adjustable
12	3219-2	4	Nut-Hex
13	3220-2	2	Nut-Jam
14	3256-2	2	Washer-Flat
15	107-3481	1	RH Motion Control ASM
16	1-808280	2	Pin-Clevis
17	3296-39	6	Nut-Lock, NI
18	103-0407	2	Arm-Shaft, Control
19	98-5975	4	Washer-Belleville
20	323-6	4	Screw-HH
21	108-7237	1	RH Lever ASM
21:1	106-9987	1	Grip-Control, Motion
22	108-7238	1	LH Lever ASM
22:1	106-9987	1	Grip-Control, Motion

Ref.	Part Number	Qty.	Description
23	323-9	6	Screw-HH
24	1-603735	2	Bushing-Flanged
25	1-603807	2	Spring-Return, Neutral
27	1-603737	2	Bolt-Return, Neutral
28	107-3470-03	2	Hydraulic Control Arm ASM
29	107-3474	1	RH Control Rod ASM
29:1	1-543017	1	Balljoint-RH
29:2	1-323245	2	Spring-Compression
29:3	103-3060	1	Knob-Tracking
29:4	3219-2	1	Nut-Hex
29:5	107-3472	1	Rod-Control, RH
29:6	1-804524	2	Nut
29:7	1-633152	1	Balljoint-LH
29:8	103-1166	1	Spacer-Tube, Pump Link
31	323-4	6	Screw-HH
32	109-2339	2	Damper-Control, Motion
33	1-803022	2	Screw-Set
34	107-3475	1	LH Control Rod ASM
34:1	1-543017	1	Balljoint-RH
34:2	3219-2	3	Nut-Hex
34:3	107-3473	1	Rod-Control, LH
34:4	1-804524	1	Nut
34:5	1-633152	1	Balljoint-LH

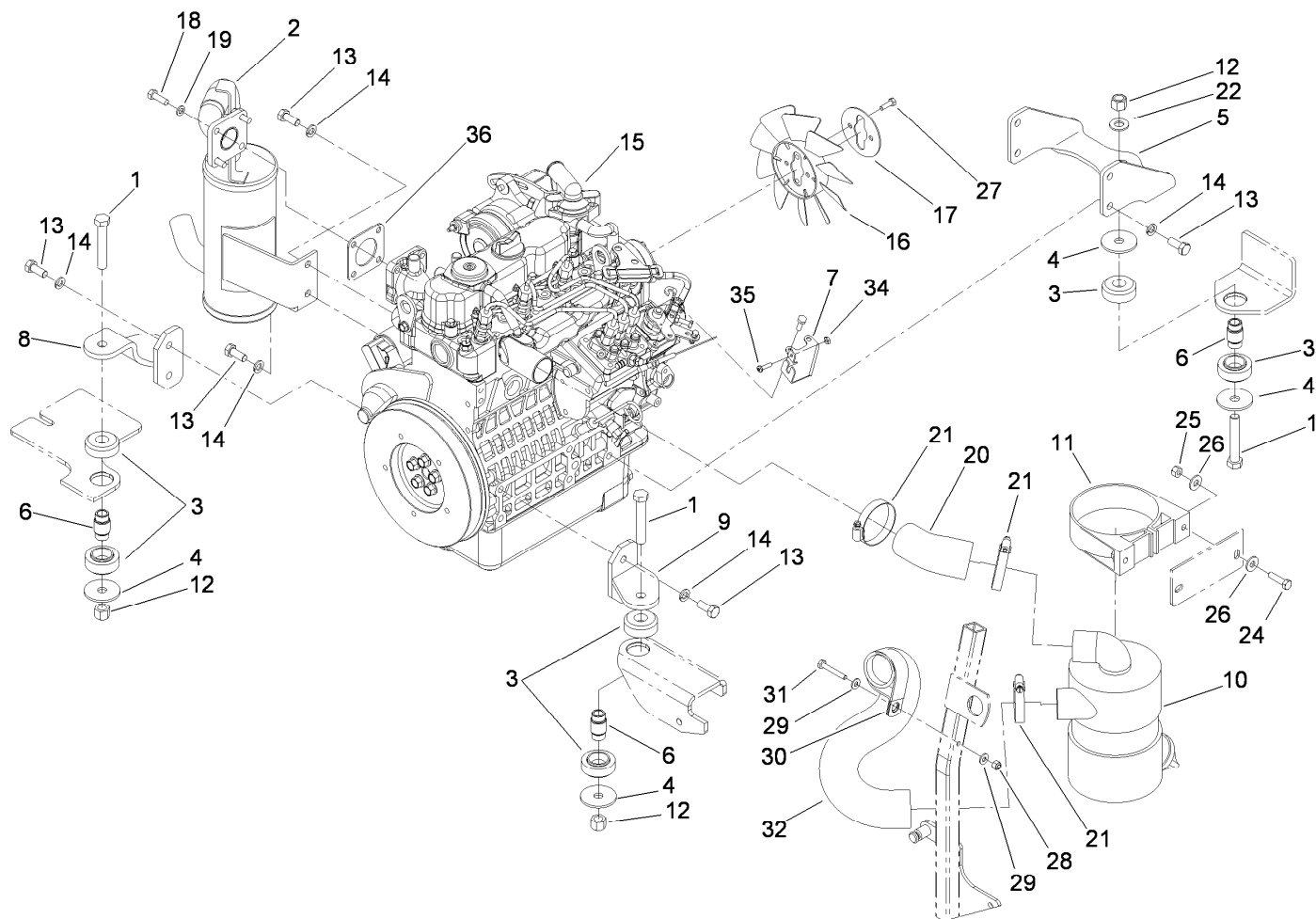

Engine, Exhaust and Air Intake Assembly

Ref.	Part Number	Qty.	Description	Ref.	Part Number	Qty.	Description
1	325-12	3	Screw-HH	18	33114-025	4	Screw-HH
2	107-9909	1	Muffler	19	3253-4	4	Washer-Lock
3	107-9914	3	Mount-Isolation	20	108-5371	1	Hose-Intake, Air Cleaner
4	55-7960	4	Washer-Large	21	1-643009	3	Clamp-Hose
5	107-9917-03	1	Bracket-Engine Mount, Rear	22	3256-26	1	Washer-Flat
6	110-0300	3	Spacer	24	322-6	2	Screw-HH
7	108-5922	1	Bracket-Support, Throttle	25	3296-29	2	Nut-Lock, NI
8	107-9920-03	1	RH Engine Support ASM	26	3256-23	4	Washer-Flat
9	107-9930-03	1	LH Engine Support ASM	27	33113-020	2	Screw-HH
10	93-2190	1	Air Cleaner ASM	28	3296-42	1	Nut-Lock, NI
11	95-5806	1	Bracket-Mounting	29	3256-22	2	Washer-Flat
12	3296-23	3	Nut-Lock, NI	30	1-643241	1	Clip-Loom
13	43-0090	10	Screw-HH	31	321-10	1	Screw-HH
14	42-9600	10	Washer-Lock, Spring	32	108-5370	1	Hose-Intake, Engine
15	114-8220	1	Engine-Kubota	34	3217-26	1	Nut-Hex
16	110-0814	1	Fan	35	110-0863	1	Screw-Torx
17	110-0816	1	Plate-Retainer, Fan	36	99-8343	1	Gasket-Muffler

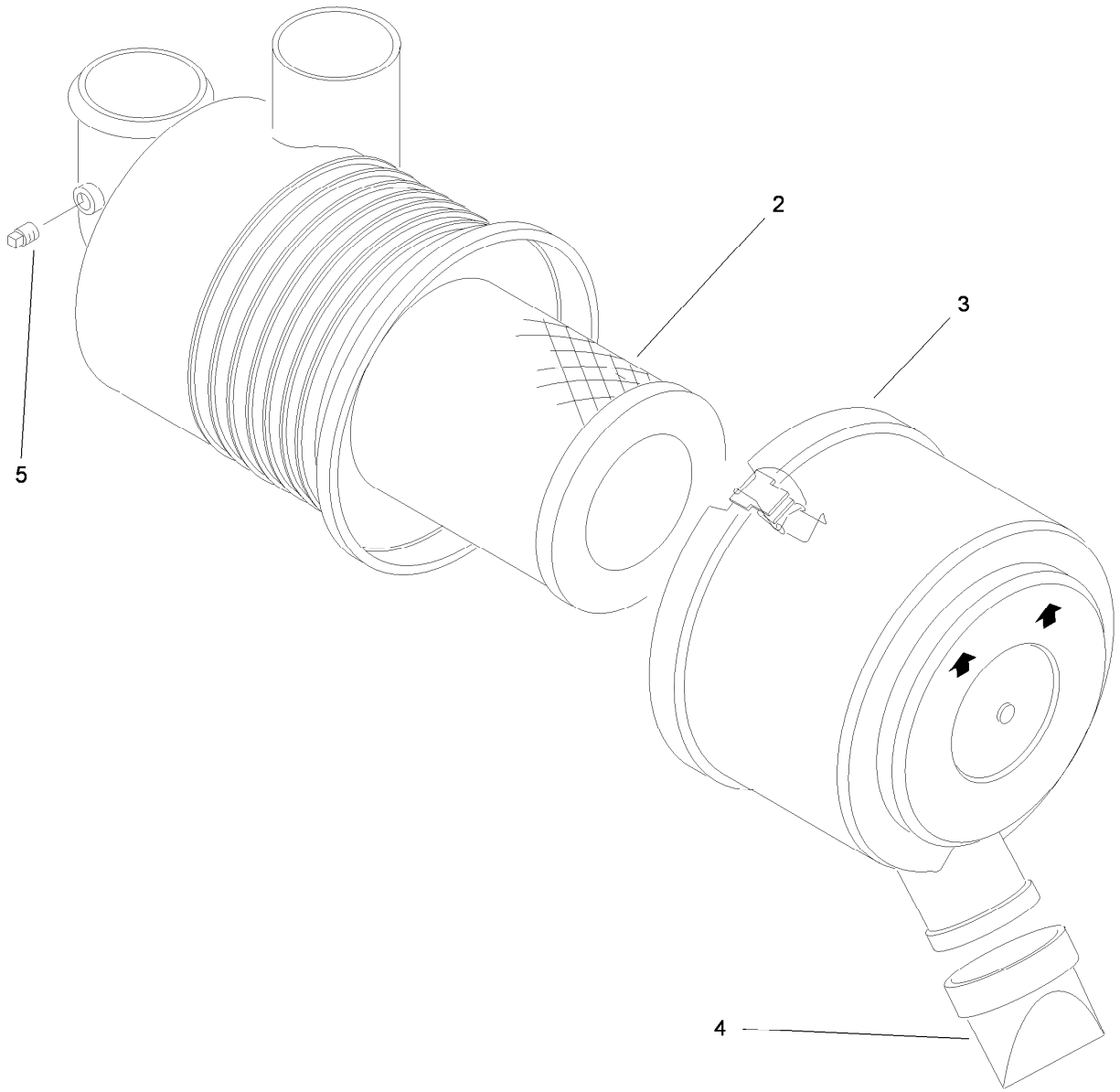

Air Cleaner Assembly No. 93-2190

<i>Ref.</i>	<i>Part Number</i>	<i>Qty.</i>	<i>Description</i>
2	108-3811	1	Filter-Air
3	94-3652	1	Cover ASM
4	87-9400	1	Valve-Vacuator
5	285-17	1	Plug-Pipe

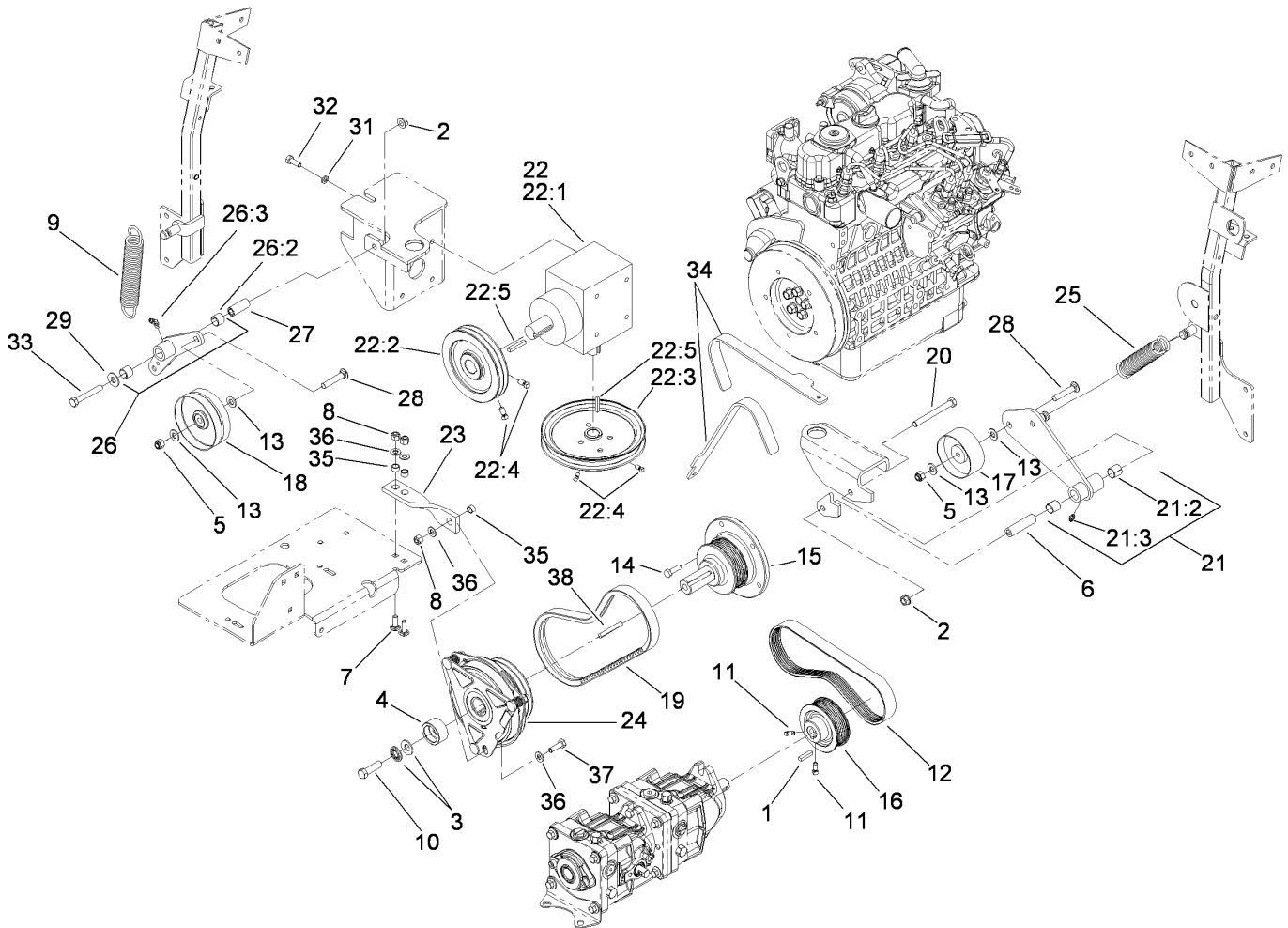

Hydro and Gearbox Assembly

Ref.	Part Number	Qty.	Description	Ref.	Part Number	Qty.	Description
1	5-0698	1	Key	22:1	107-9887	1	Gearbox-90 DEG
2	3290-357	2	Nut-HHF, Whiz	22:2	108-5912	1	Pulley
3	1-603610	2	Washer-Spring	22:3	110-0893	1	Pulley
4	114-8152	1	Retainer-Clutch	22:4	1-803022	4	Screw-Set
5	3296-39	2	Nut-Lock, NI	22:5	67-7490	2	Key-Square
6	1-603384	1	Bushing-Pivot, Idler	23	112-1781	1	Strap-Stop, Clutch
7	3230-22	2	Screw-CARR	24	112-2320	1	Clutch-Magnetic
8	3296-29	3	Nut-Lock, NI	25	119-0394	1	Spring-Extension
9	119-0392	1	Spring-Extension	26	112-2354	1	Gearbox Idler ASM (W/Bearings)
10	3212-6	1	Screw-HH	26:2	103-4681	2	Sleeve-Bearing
11	1-803022	2	Screw-Set	26:3	1481	1	Fitting-Grease
12	107-9910	1	Belt-V	27	1-603044	1	Bushing
13	3256-24	5	Washer-Flat	28	3231-6	2	Screw-CARR
14	33114-025	5	Screw-HH	29	3256-4	1	Washer-Flat
15	112-2335	1	Stub Shaft	31	3253-4	4	Washer-Lock
16	108-5976	1	Pulley	32	322-4	4	Screw-HH
17	108-5910	1	Pulley-Flat	33	323-12	1	Screw-HH
18	110-0803	1	Pulley-Flat	34	110-0876	1	Tool-Alignment, Pulley
19	110-0805	1	Belt-V	35	65-9820	3	Spacer
20	323-15	1	Screw-HH	36	3256-23	4	Washer-Flat
21	108-5939	1	Pump Idler Arm ASM	37	322-5	1	Screw-HH
21:2	1-513034	2	Sleeve-Bearing	38	5-1336	1	Key-Square
21:3	302-5	1	Fitting-Grease				
22		1	Gearbox ●				

● Not serviced separately

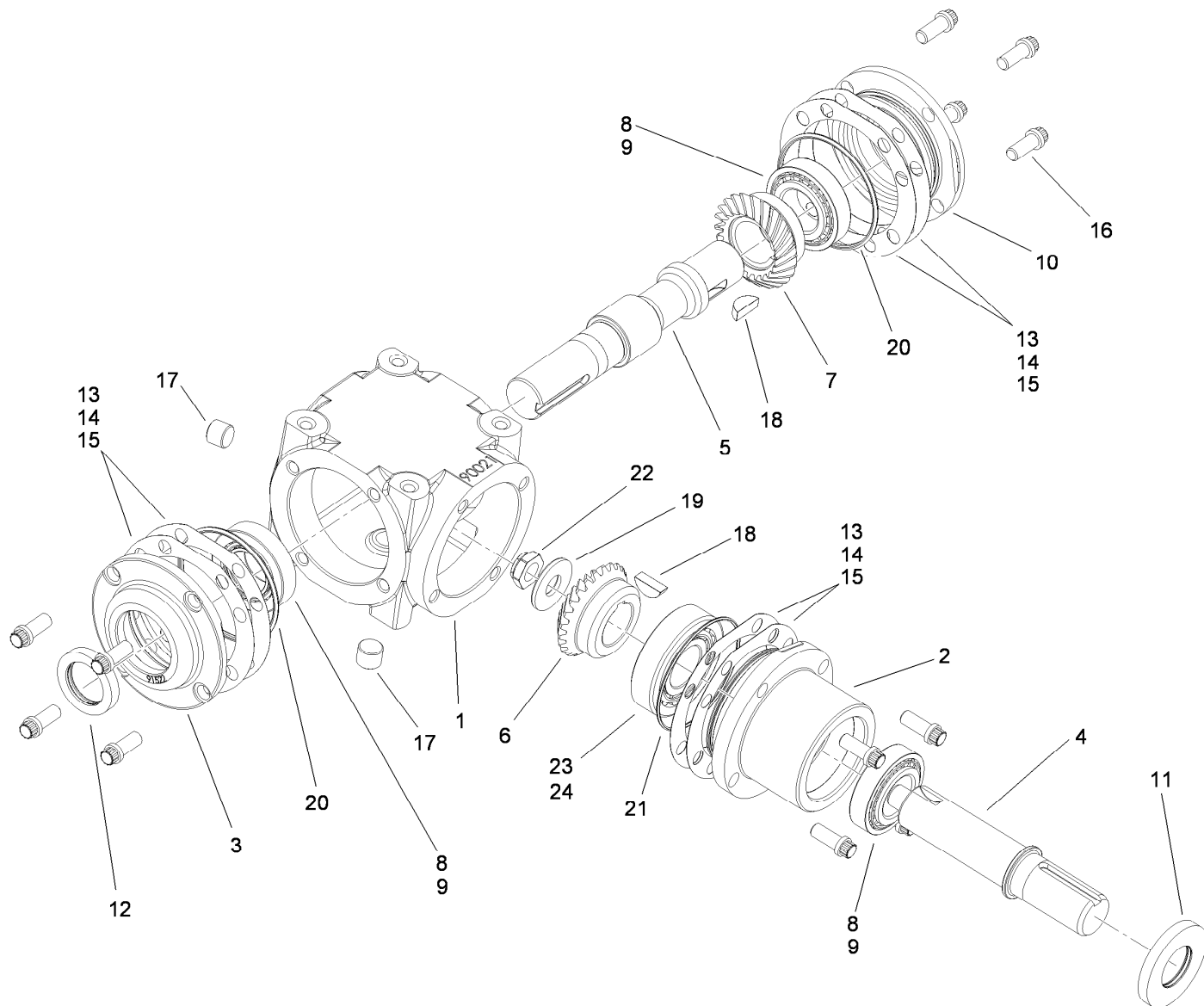

Gearbox Assembly No. 107-9887

<i>Ref.</i>	<i>Part Number</i>	<i>Qty.</i>	<i>Description</i>	<i>Ref.</i>	<i>Part Number</i>	<i>Qty.</i>	<i>Description</i>
1	110-0843	1	Case	13	100-4591	1	Shim-Brown, .010In
2	110-0853	1	Housing-Pinion	14	100-4592	1	Shim-Blue, .005In
3	100-4566	1	Cap-End, Open	15	100-4593	1	Shim-Green, .003In
4	110-0844	1	Shaft-Pinion	16	100-4578	12	Screw
5	110-0845	1	Shaft-Cross	17	100-4579	2	Plug
6	110-0847	1	Gear-Shaft, Cross	18	3257-33	2	Key-Woodruff
7	110-0846	1	Gear-Pinion	19	100-4581	1	Washer
8	110-0848	3	Bearing-Cup	20	100-4582	2	O-Ring
9	110-0849	3	Bearing-Cone	21	110-0851	1	O-Ring
10	100-4574	1	Cap-End, Closed	22	110-0852	1	Nut Lock
11	100-4575	1	Seal	23	100-5817	1	Bearing-Cup
12	110-0850	1	Seal-Shaft, Cross	24	100-5816	1	Bearing-Cone

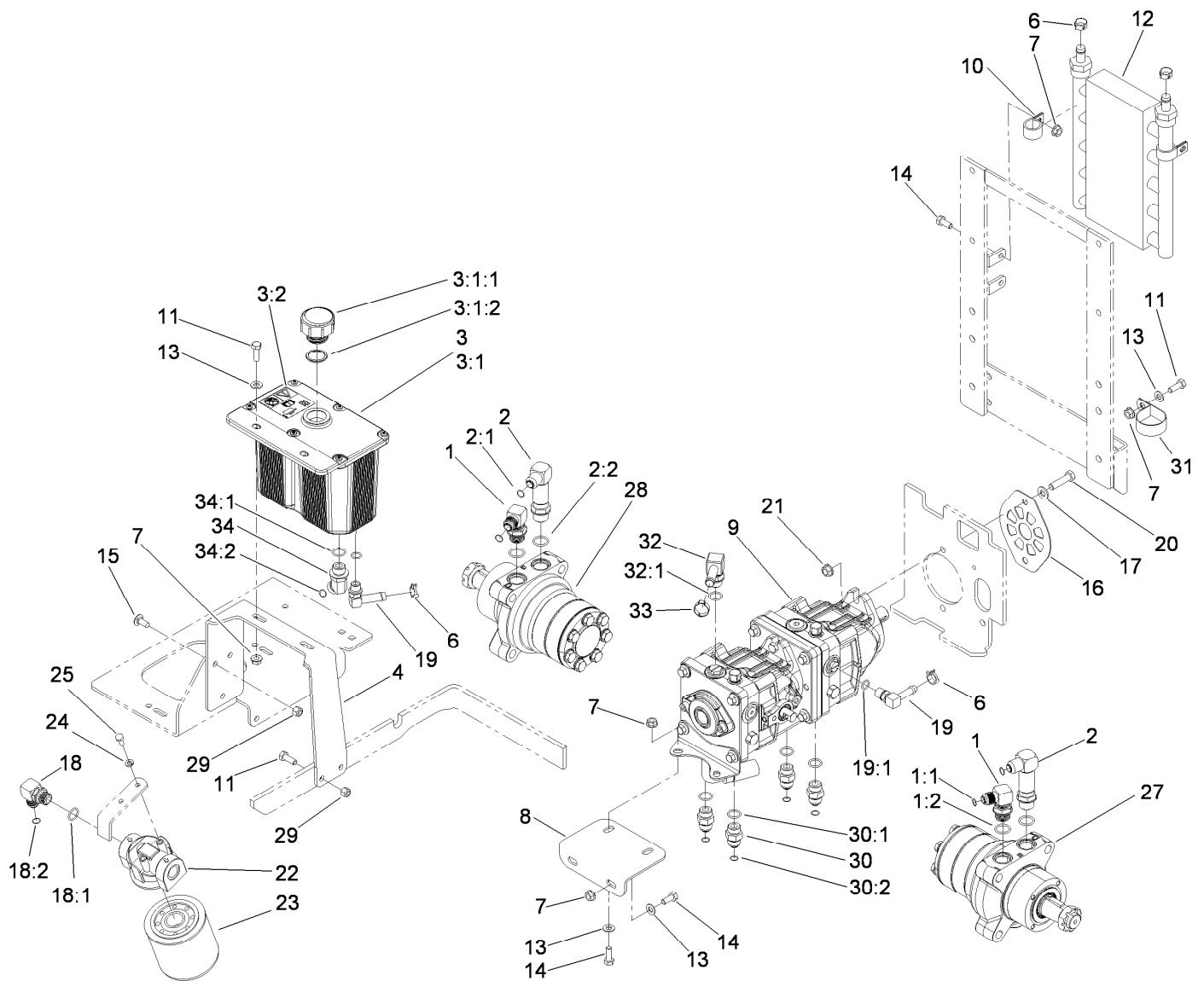

Hydraulic Tank, Motor and Pump Assembly

Ref.	Part Number	Qty.	Description	Ref.	Part Number	Qty.	Description
1	1-633605	2	Fitting-HYD, 90 DEG	13	3256-23	7	Washer-Flat
1:1	1-603992	1	O-Ring	14	322-3	8	Screw-HH
1:2	237-80	1	O-Ring	15	3230-23	3	Screw-CARR
2	108-5323	2	Fitting-Elbow-90	16	108-5367-03	1	Plate-Shield, Pump
2:1	1-603992	1	O-Ring	17	3256-24	2	Washer-Flat
2:2	237-80	1	O-Ring	18	103-2153	1	Fitting-90 DEG
3	108-5320	1	Hydraulic Tank ASM	18:1	1-603920	1	O-Ring
3:1		1	Tank-Hydraulic ●	18:2	1-603992	1	O-Ring
3:1:1	103-1948	1	Cap-Reservoir, HYD	19	109-6449	2	Fitting-Elbow, 90
3:1:2	103-1949	1	Gasket-Cap	19:1	237-42	1	O-Ring
3:2	115-4212	1	Decal-Warning	20	323-8	2	Screw-HH
4	108-5352-03	1	Bracket-Tank, Hydraulic	21	3290-357	2	Nut-HHF, Whiz
6	110-6242	4	Clamp-Hose	22	86-9080	1	Head-Filter
7	32128-20	11	Nut-HF	23	67-8110	1	Cartridge-Filter, Oil
8	107-3462-03	1	Bracket-Pump, Front	24	1-805004	2	Washer-Lock
9	107-9885	1	Tandem Pump ASM	25	321-3	2	Screw-HH
10	110-0824	4	R-Clamp	27	112-8357	1	HYD Motor ASM (CCW)
11	322-5	4	Screw-HH	28	112-8358	1	HYD Motor ASM (CW)
12	114-8168	1	Cooler-Oil, Hydro	29	3296-29	4	Nut-Lock, NI

● Not serviced separately

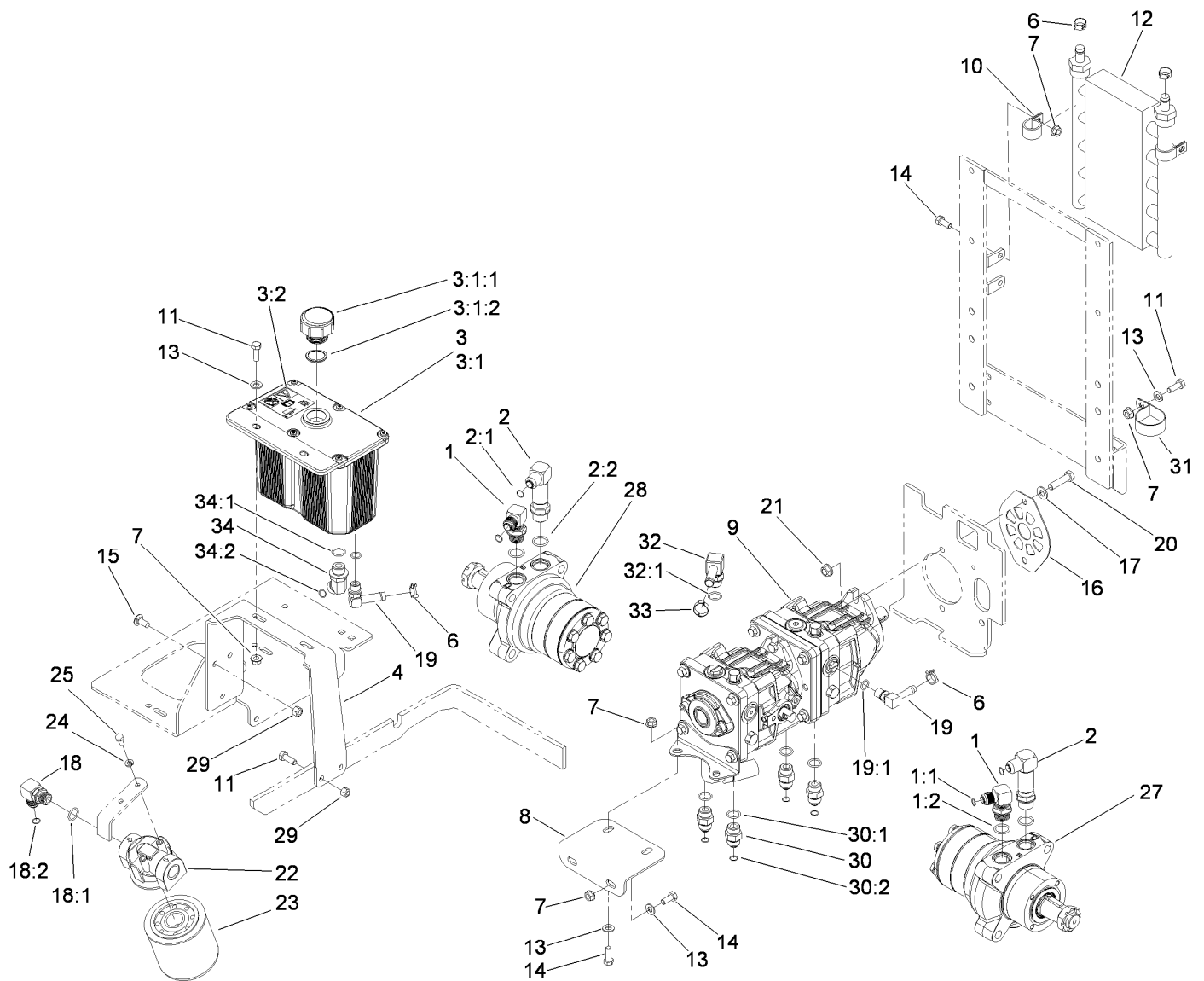

Hydraulic Tank, Motor and Pump Assembly (continued)

<i>Ref.</i>	<i>Part Number</i>	<i>Qty.</i>	<i>Description</i>	<i>Ref.</i>	<i>Part Number</i>	<i>Qty.</i>	<i>Description</i>
30	1-603990	4	Fitting-Straight	32:1	237-79	1	O-Ring
30:1	1-603920	1	O-Ring	33	103-2104	1	Clamp-Hose
30:2	1-603992	1	O-Ring	34	1-523221	1	Fitting-HYD, 45 DEG
31	2412-147	1	Clamp	34:1	1-603920	1	O-Ring
32	108-5316	1	Fitting-Elbow, 90 DEG	34:2	1-603992	1	O-Ring

● Not serviced separately

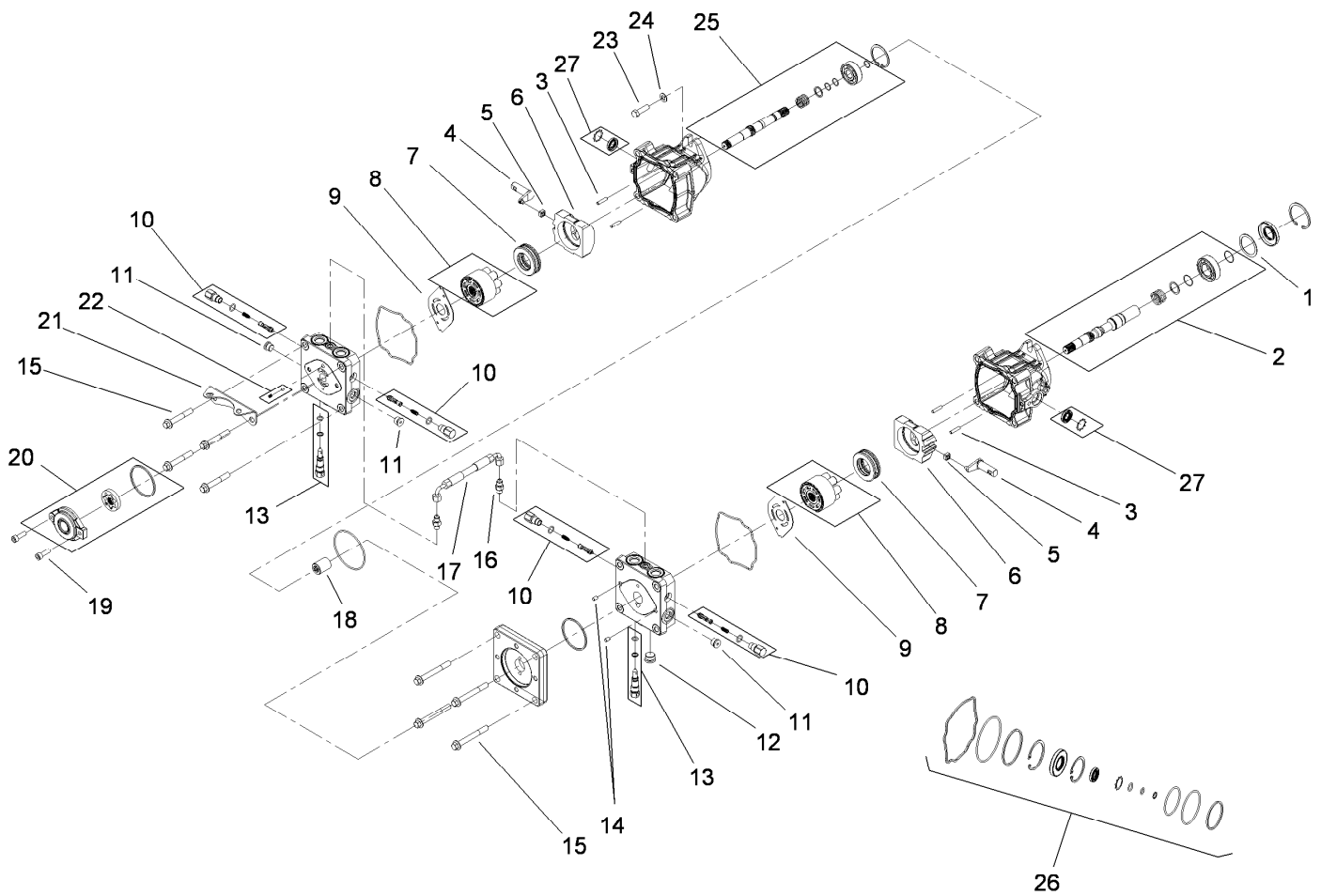

Tandem Pump Assembly No. 107-9885

<i>Ref.</i>	<i>Part Number</i>	<i>Qty.</i>	<i>Description</i>	<i>Ref.</i>	<i>Part Number</i>	<i>Qty.</i>	<i>Description</i>
1	112-4168	1	Spacer	15	112-4157	8	Bolt
2	112-4151	1	Input Pump Shaft Kit	16	117-7842	2	Fitting-Straight
3	106-8753	4	Pin-Headless, Straight	17	117-7843	1	Hose ASM
4	112-4152	2	Arm-Trunnion	18	112-4160	1	Coupling
5	94-1910	2	Guide-Slot	19	112-4161	2	Bolt
6	112-4153	2	Swashplate	20	112-4162	1	Charge Pump Kit
7	112-4154	2	Bearing-Thrust	21	112-4163	1	Bracket-Support, Pump
8	108-2112	2	Cylinder Block Kit	22	112-4164	1	Charge Relief Kit
9	108-6801	2	Plate-Valve	23	112-4165	2	Bolt-HSH
10	112-4155	4	Shock Valve Kit	24	112-4166	2	Washer
11	104-2189	3	Plug-Thread, Straight	25	112-4167	1	Second Pump Shaft Kit
12	112-4156	1	Plug-Steel	26	112-4150	1	Overhaul Seal Kit
13	106-8759	2	Bypass Valve Kit	27	114-8155	1	Trunnion Seal Kit
14	104-2170	2	Pin				

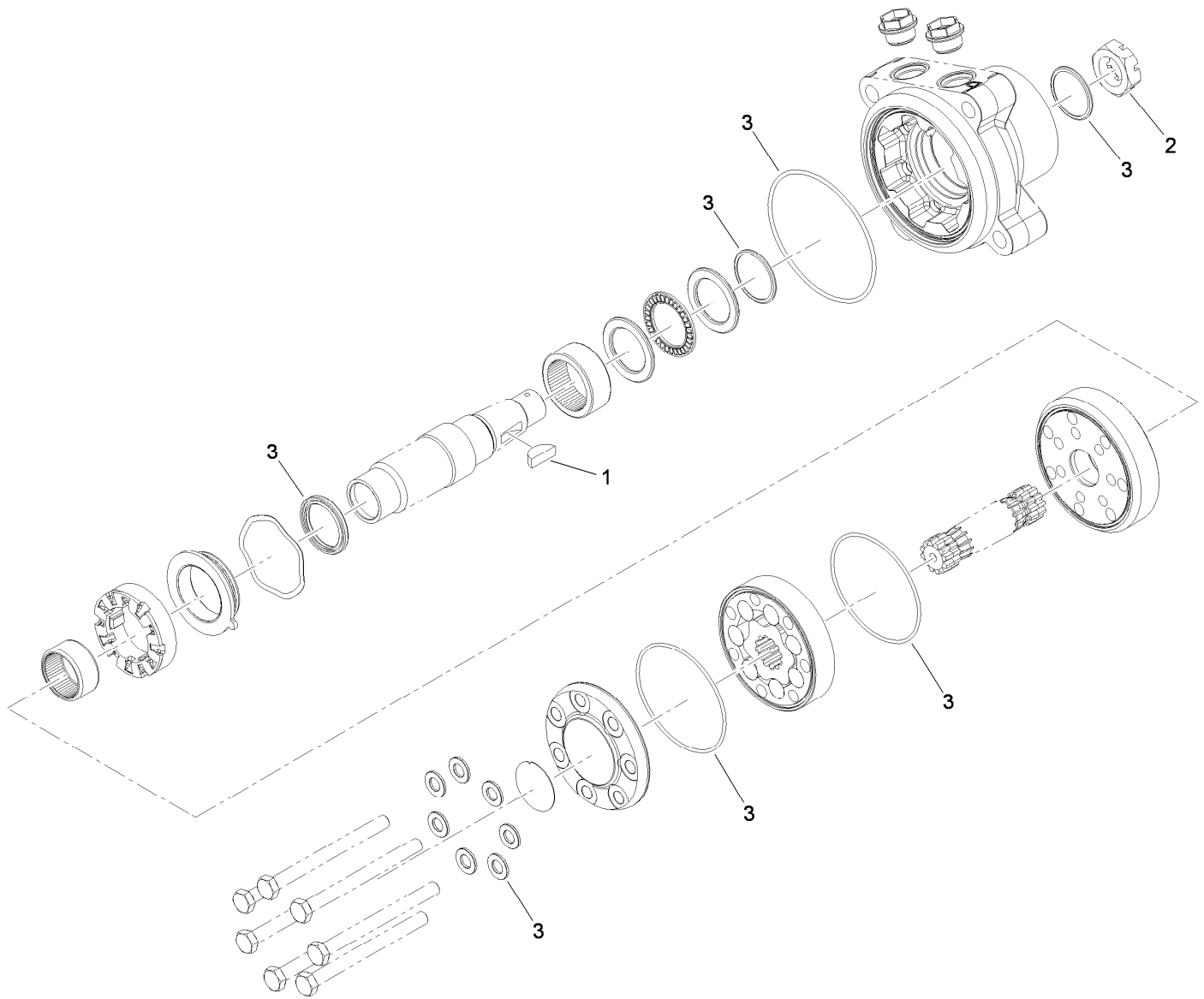

Hydraulic Motor Assembly No. 112-8357 (CCW)

<i>Ref.</i>	<i>Part Number</i>	<i>Qty.</i>	<i>Description</i>
1	3257-42	1	Key-Woodruff
2	1-809036	1	Nut-HH
3	109-5966	1	Wheel Motor Seal Kit ●

● Not illustrated

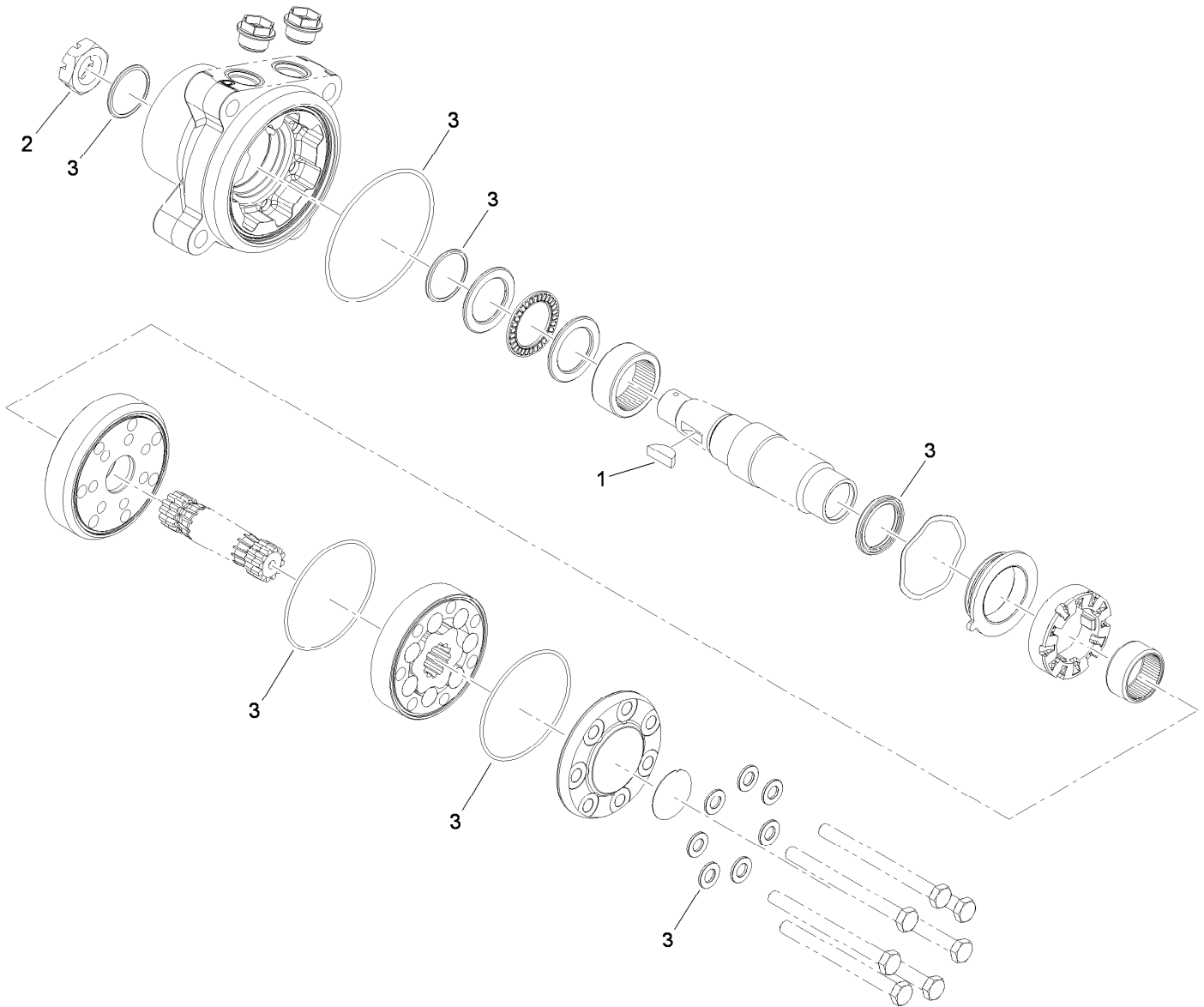

Hydraulic Motor Assembly No. 112-8358 (CW)

<i>Ref.</i>	<i>Part Number</i>	<i>Qty.</i>	<i>Description</i>
1	3257-42	1	Key-Woodruff
2	1-809036	1	Nut-HH
3	109-5966	1	Wheel Motor Seal Kit ●

● Not illustrated

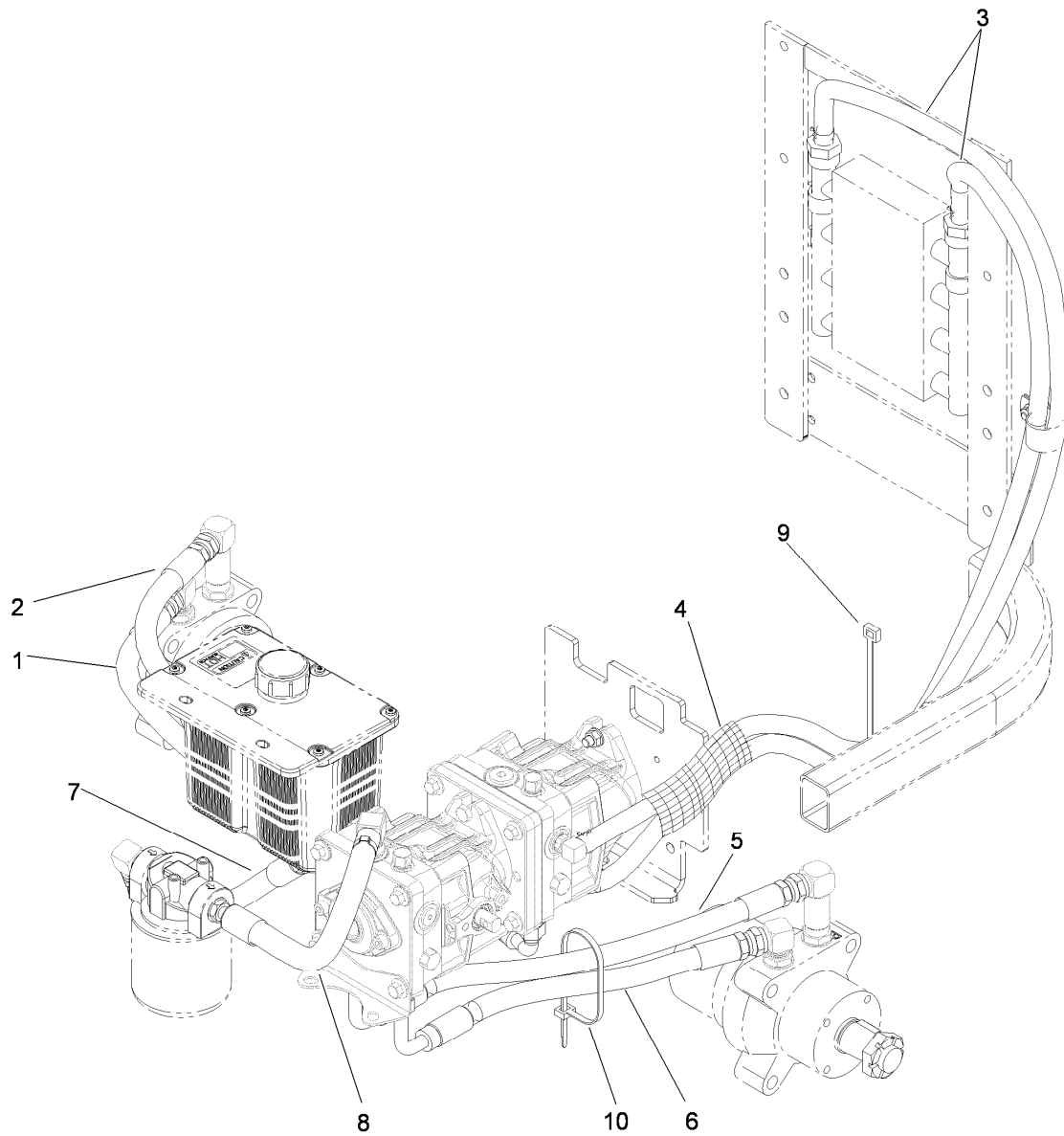

Hydraulic Hose System Assembly

<i>Ref.</i>	<i>Part Number</i>	<i>Qty.</i>	<i>Description</i>
1	107-3495	1	Hydraulic Hose ASM
2	107-3490	1	Hydraulic Hose ASM
3	114-8169	2	Hose-Hydraulic
4	114-8201	1	Sleeve-Fabric
5	108-5318	1	Hydraulic Hose ASM
6	107-3491	1	Hydraulic Hose ASM
7	110-3854	1	Hydraulic Hose ASM
8	108-5374	1	Hydraulic Hose ASM
9	1-303335	1	Tie-Plastic
10	1-809066	1	Tie-Plastic

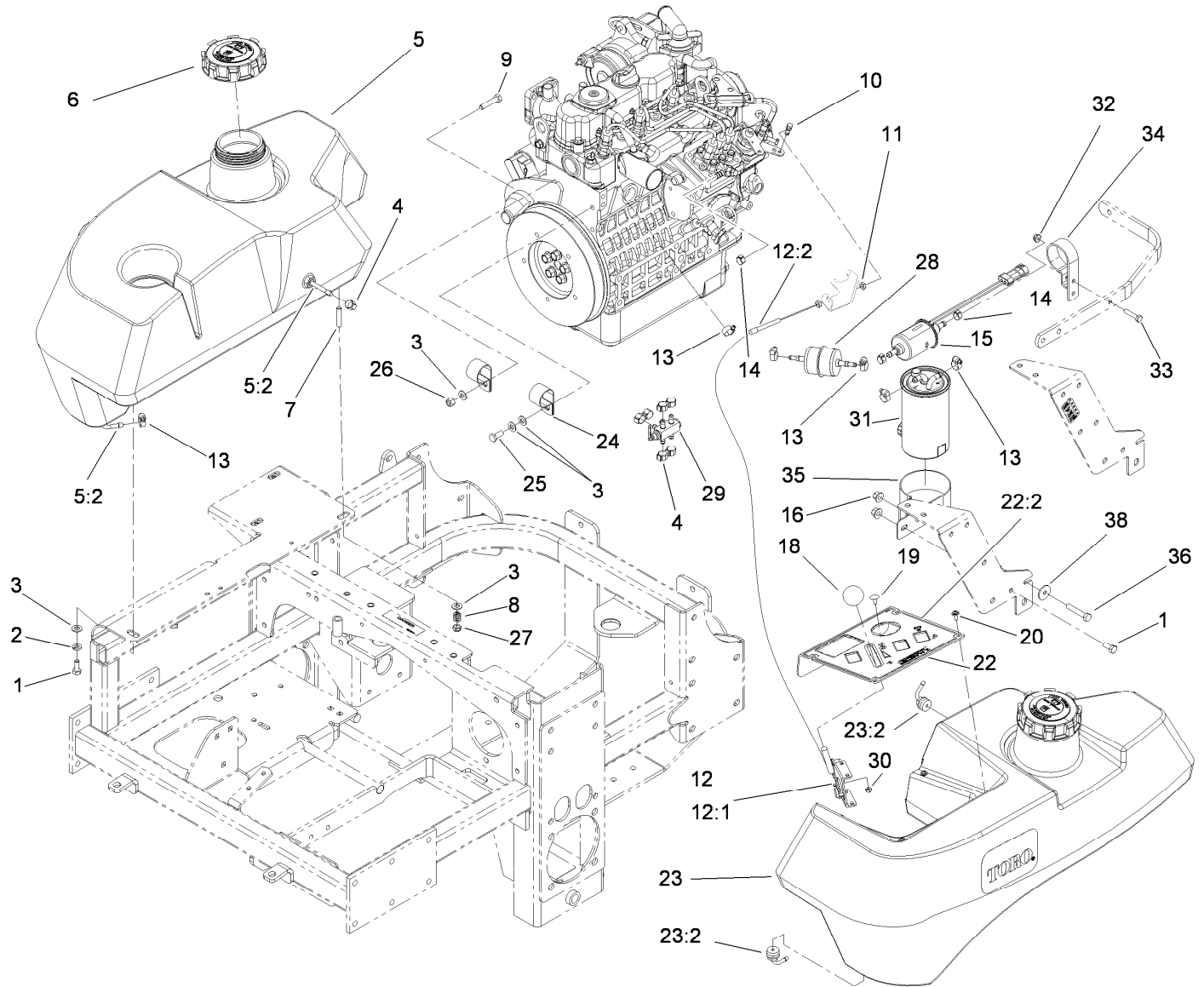

Fuel System and Throttle Control Assembly

Ref.	Part Number	Qty.	Description	Ref.	Part Number	Qty.	Description
1	322-3	3	Screw-HH	19	1-807513	2	Bolt-CARR
2	1-805005	2	Washer-Lock	20	109-2661	4	Screw-PPH
3	3256-23	11	Washer-Flat	22	117-0913	1	Control Panel ASM
4	1-643293	8	Clamp-Hose, Fuel	22:2	117-0912	1	Decal-Panel, Control
5	114-8221	1	RH Fuel Tank ASM	23	114-8222	1	LH Fuel Tank ASM
5:2	103-2615	2	Fitting-Fuel, Bulkhead	23:2	103-2615	2	Fitting-Fuel, Bulkhead
6	114-5062	2	Cap-Biodiesel	24	1-643312	2	Clip-Loom
7	1-633023	6	Stud	25	33114-020	1	Screw-HH
8	1-633349	6	Spring-Tank, Fuel	26	3296-29	1	Nut-Lock, NI
9	322-7	1	Screw-HH	27	3296-47	6	Nut-Lock, NI
10	108-5928	1	Swivel-Stop, Cable	28	112-7836	1	Filter-Inline
11	3220-1	2	Nut-Jam	29	1-643234	1	Valve-Fuel, Dual Flow
12	108-5927	1	Cable-Control, Throttle	30	3296-2	2	Nut-Lock, NI
12:1	112-2333	1	Lever-Cable, Throttle	31	112-9188	1	Element-Filter, Fuel/Water
12:2	108-6337	1	Cable-Throttle	32	104-7201	1	Nut-HF
13	2412-108	7	Clamp-Worm	33	321-8	1	Screw-HH
14	1-643277	3	Clamp-Hose, Fuel	34	110-8817	1	Bracket-Pump, Fuel
15	110-8806	1	Pump-Fuel	35	110-8807	1	Bracket-Filter, Fuel
16	3296-58	2	Nut-Lock, NI	36	322-9	1	Screw-HH
18	1-603175	1	Knob-Ball	38	3256-82	1	Washer-Flat

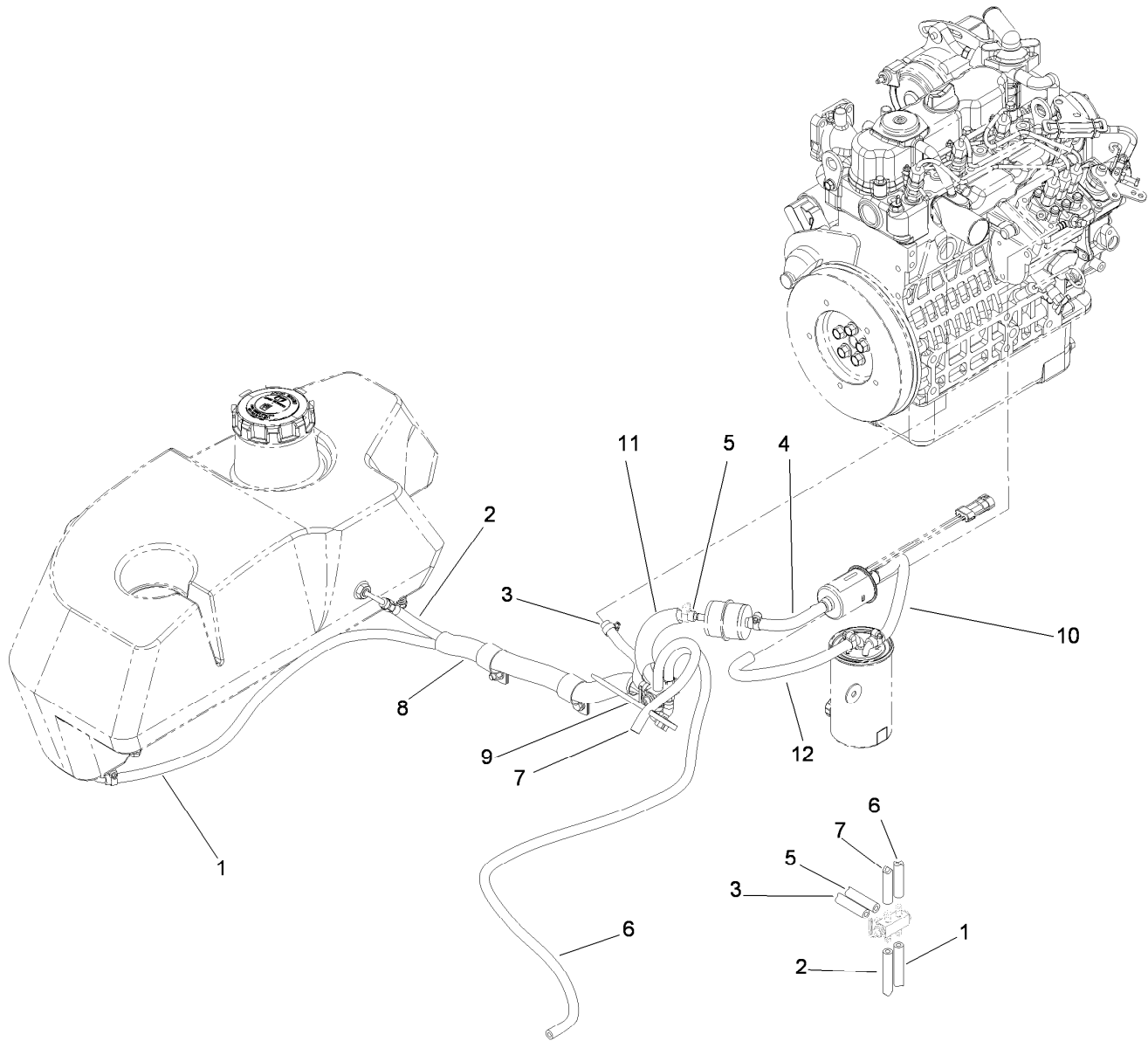

Fuel Line Assembly

<i>Ref.</i>	<i>Part Number</i>	<i>Qty.</i>	<i>Description</i>
1	108-5376	1	Hose-Fuel
2	109-0301	1	Hose-Fuel
3	110-1876	1	Hose-Fuel
4	108-3283	1	Hose-Fuel
5	109-0303	1	Hose-Fuel
6	109-0275	1	Hose-Fuel
7	109-0297	1	Hose-Fuel
8	108-5377	1	Sleeve-Fabric
9	1-303335	1	Tie-Plastic
10	110-4124	1	Hose-Fuel
11	114-8224	1	Conduit-Fuel Line
12	110-4105	1	Hose-Fuel

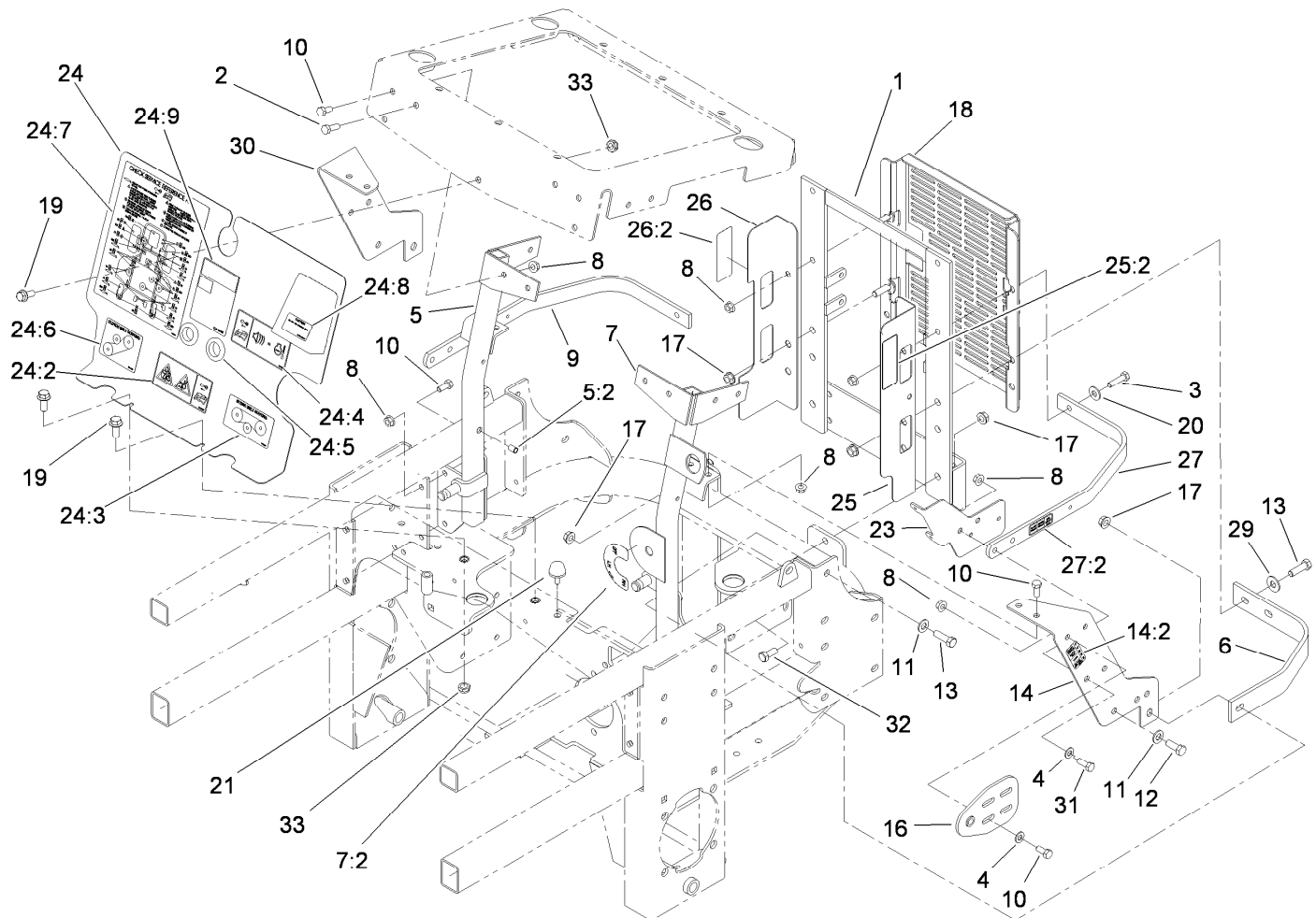

Engine Housing Assembly

Ref.	Part Number	Qty.	Description
1	107-9934-03	1	Support-Radiator, Rear
2	322-5	2	Screw-HH
3	322-6	2	Screw-HH
4	3256-23	8	Washer-Flat
5	114-1170	1	RH Radiator Brace ASM
5:2	32148-11	1	Insert-Threaded
6	103-7623-03	2	Strap-Guard
7	110-3870	1	LH Radiator Brace ASM
7:2	107-2114	1	Decal-Valve, Fuel
8	32128-20	22	Nut-HF
9	114-8223-03	1	Top-Rib
10	322-3	14	Screw-HH
11	3256-24	3	Washer-Flat
12	323-6	1	Screw-HH
13	323-7	4	Screw-HH
14	119-6650	1	LH Support Bracket ASM
14:2	119-0398	1	Decal-Fuse
16	108-5345-03	2	Plate-Pivot, Hood
17	3290-357	7	Nut-HHF, Whiz
18	112-8302-03	1	Shield-Cooler
19	3234-21	3	Screw-HHF
20	3256-3	2	Washer-Flat
21	109-2365	2	Rubber Bumper ASM (W/Stud)

Ref.	Part Number	Qty.	Description
23	119-0393-03	1	Bracket-Relay, Fuse
24	108-5936	1	Front Engine Shield ASM
24:2	110-3853	1	Decal-Danger, Rotating Devices
24:3	108-5955	1	Decal-Routing, Hydro Belt
24:4	110-3852	1	Decal- Warning, Buzzer
24:5	100-3815	2	Grommet-Rubber
24:6	108-5957	1	Decal-Routing, Clutch Belt
24:7	110-3851	1	Decal-Check, Service
24:8	110-0806	1	Decal- Caution
24:9	104-2449	1	Decal-Coolant
25	110-0879	1	Guard-Fan, LH (Ce)
25:2	107-7719	1	Decal-Danger
26	110-0888	1	Guard-Fan, RH (Ce)
26:2	107-7719	1	Decal-Danger
27	119-0399	1	Top Strap ASM
27:2	119-0397	1	Decal-Relay
29	3256-4	2	Washer-Flat
30	108-5339-03	1	Bracket-Support, RH
31	322-4	4	Screw-HH
32	323-5	2	Screw-HH
33	3296-56	3	Nut-Lock, NI

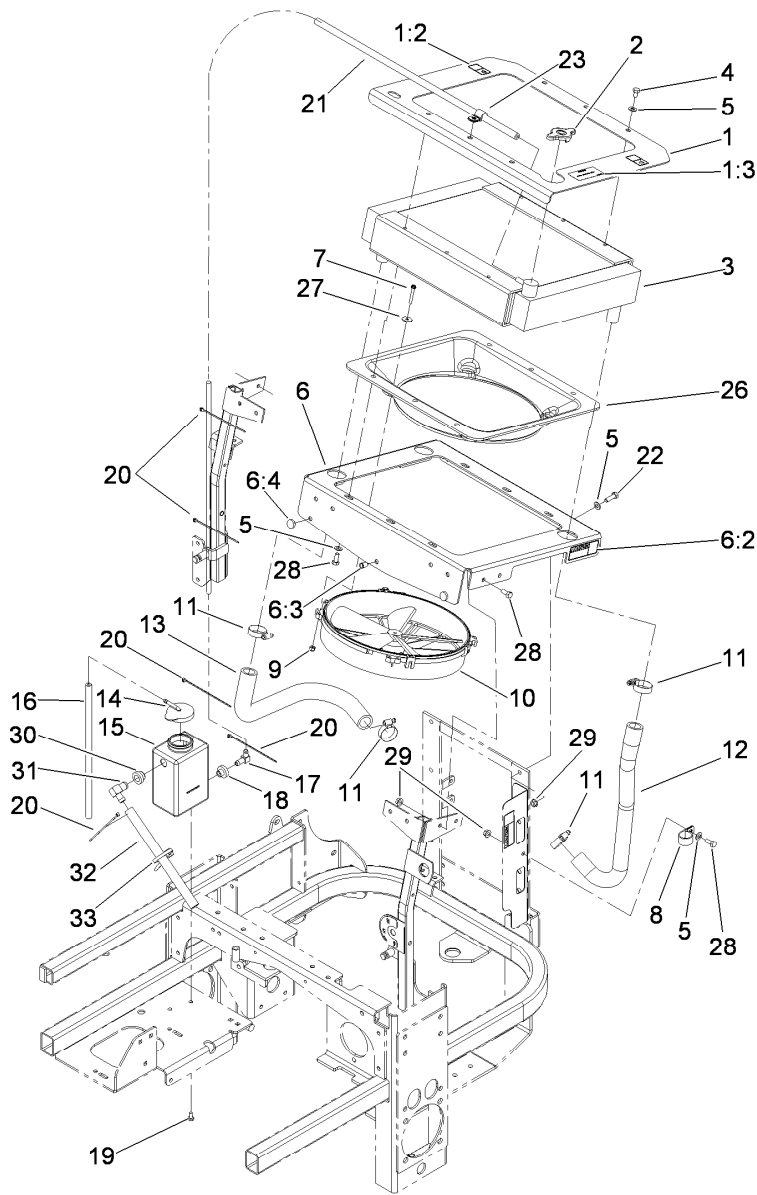

Cooling System Assembly

Ref.	Part Number	Qty.	Description	Ref.	Part Number	Qty.	Description
1	110-3845	1	Top Radiator Plate ASM	14	1-643164	1	Cap-Tank, Overflow
1:2	93-8069	2	Decal-Surface, Hot	15	117-0941	1	Tank-Overflow
1:3	110-3842	1	Decal-Antifreeze	16	1-603954	1	Hose-Line, Fuel
2	1-643161	1	Cap-Radiator	17	1-643259	1	Fitting-Elbow
3	107-9932	1	Radiator	18	1-513645	1	Bushing-Valve, Fuel
4	322-1	6	Screw-HH	19	321-2	2	Screw-HH
5	3256-23	16	Washer-Flat	20	1-303287	6	Tie-Cable
6	110-0880	1	Bottom Radiator Plate ASM	21	103-1428	1	Hose-Overflow
6:2	107-7719	2	Decal-Danger	22	322-5	3	Screw-HH
6:3	32148-6	1	Insert-Nut	23	1-603727	1	Clip-Loom
6:4	1-513658	2	Bumper	26	108-5971	1	Shroud-Cooling, Engine
7	108-5988	4	Screw	27	3256-67	4	Washer-Flat
8	1-643312	1	Clip-Loom	28	322-3	10	Screw-HH
9	1-804254	4	Nut-Lock, HH	29	32128-20	3	Nut-HF
10	1-633831	1	Fan	30	104-0790	1	Bushing
11	1-633989	4	Clamp-Hose	31	117-0943	1	Fitting-Elbow
12	108-5372	1	Hose-Radiator, LH	32	115-4969	1	Hose-Overflow
13	108-5904	1	Hose-Outlet, Engine	33	1-303335	1	Tie-Plastic

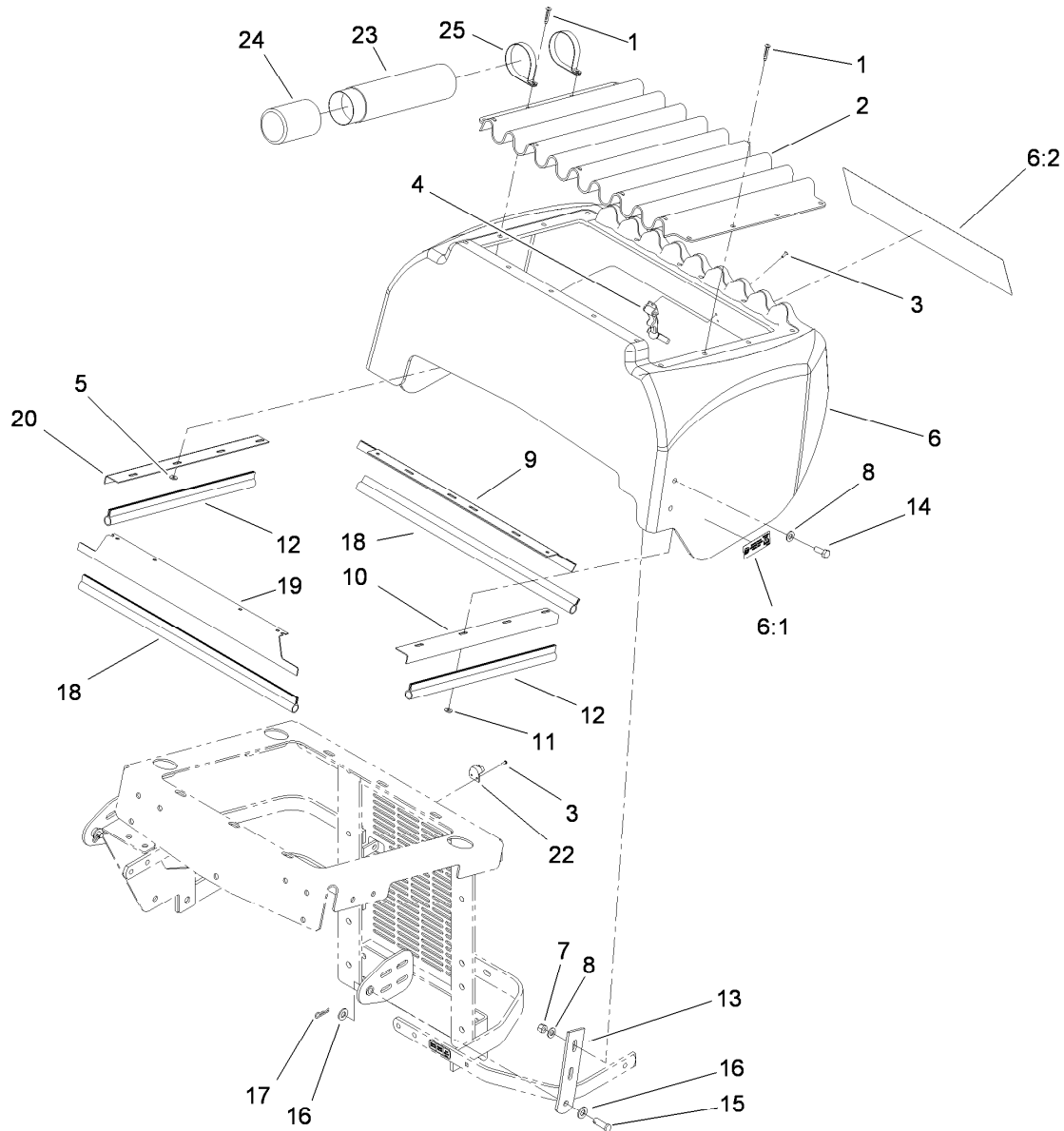

Hood Assembly

Ref.	Part Number	Qty.	Description	Ref.	Part Number	Qty.	Description
1	1-803072	17	Rivet	12	1-643186	2	Seal-Trim
2	1-633864-03	1	Screen-Radiator	13	108-5337-03	2	Plate-Hinge, Hood
3	923786	4	Rivet	14	322-4	4	Screw-HH
4	1-643188	1	Latch-Rubber	15	1-808285	2	Pin-Clevis
5	1-303435	4	Washer-Spring	16	3256-24	4	Washer-Flat
6	114-8225	1	Hood ASM	17	1-806003	2	Pin-Cotter, Hair
6:1	114-9600	2	Decal-Low Sulfur	18	1-643187	2	Seal-Trim
6:2	107-7674	1	Decal	19	1-643107-03	1	Angle-Radiator, Top
7	3296-29	4	Nut-Lock, NI	20	1-643106-03	1	Angle-Radiator, RH
8	3256-23	8	Washer-Flat	22	1-643189	1	Keeper-Latch, Rubber
9	1-643108-03	1	Angle-Radiator, Bottom	23	104-7050	1	Tube-Manual
10	1-643105-03	1	Angle-Radiator, LH	24	104-7048	1	Cap-Housing
11	3256-14	12	Washer-Flat	25	2412-120	2	R-Clamp

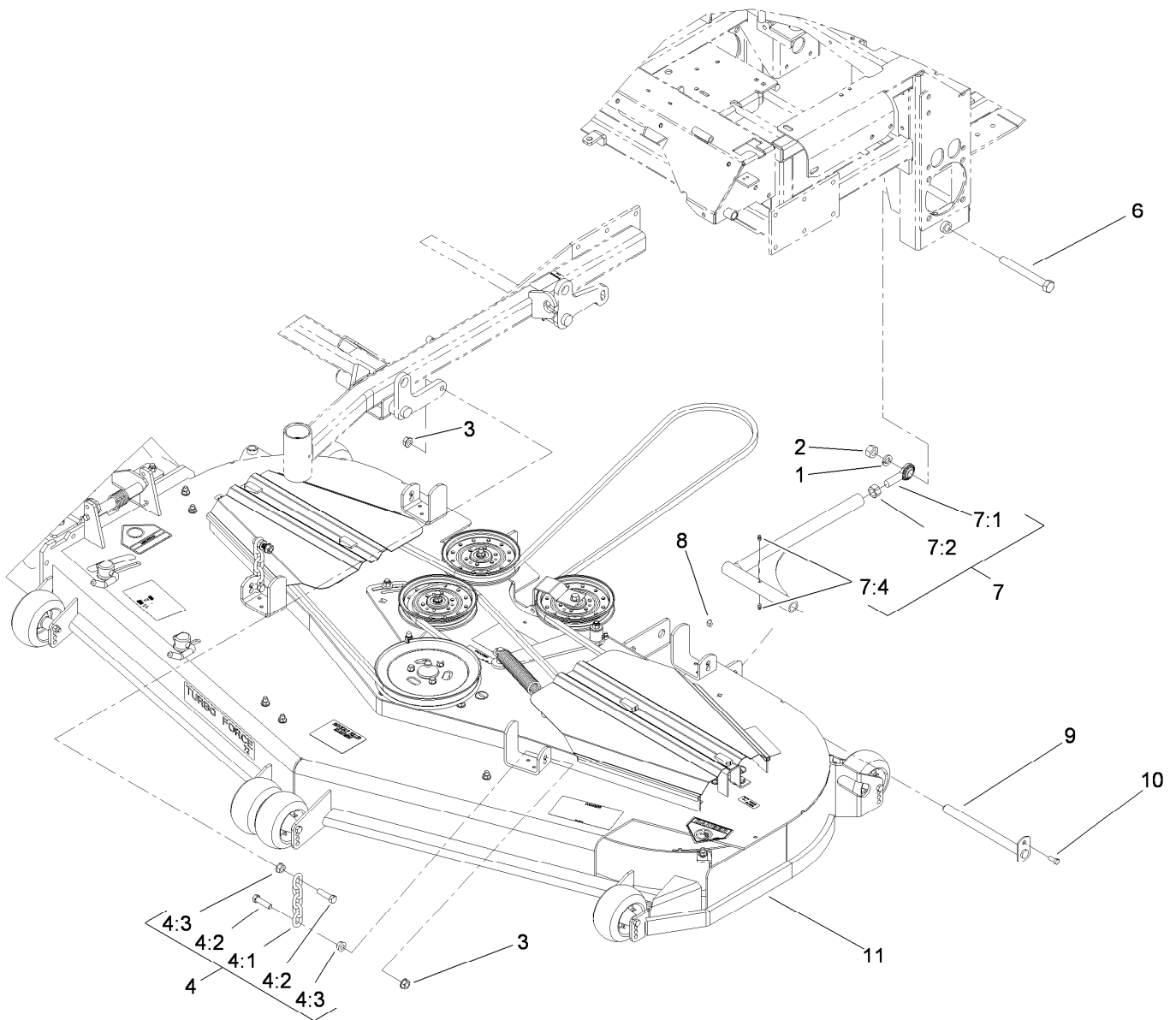

Deck Connection Assembly

Ref.	Part Number	Qty.	Description	Ref.	Part Number	Qty.	Description
1	3253-8	2	Washer-Lock	7	108-5969	2	Strut ASM
2	3217-11	2	Nut-Hex	7:1	1-633029	1	Balljoint-Spherical
3	32128-37	8	Nut-HF	7:2	3219-6	1	Nut-Hex
4	103-9792	4	Deck Chain ASM	7:4	109-1380	1	Fitting-Grease
4:1	1-633447	1	Chain-Lift, Deck	8	3296-29	2	Nut-Lock, NI
4:2	103-1898	2	Screw-HH	9	1-632199-01	2	Pin-Strut
4:3	32128-37	2	Nut-HF	10	322-3	2	Screw-HH
6	327-28	2	Screw-HH	11		1	Deck ASM ●

● Not serviced separately

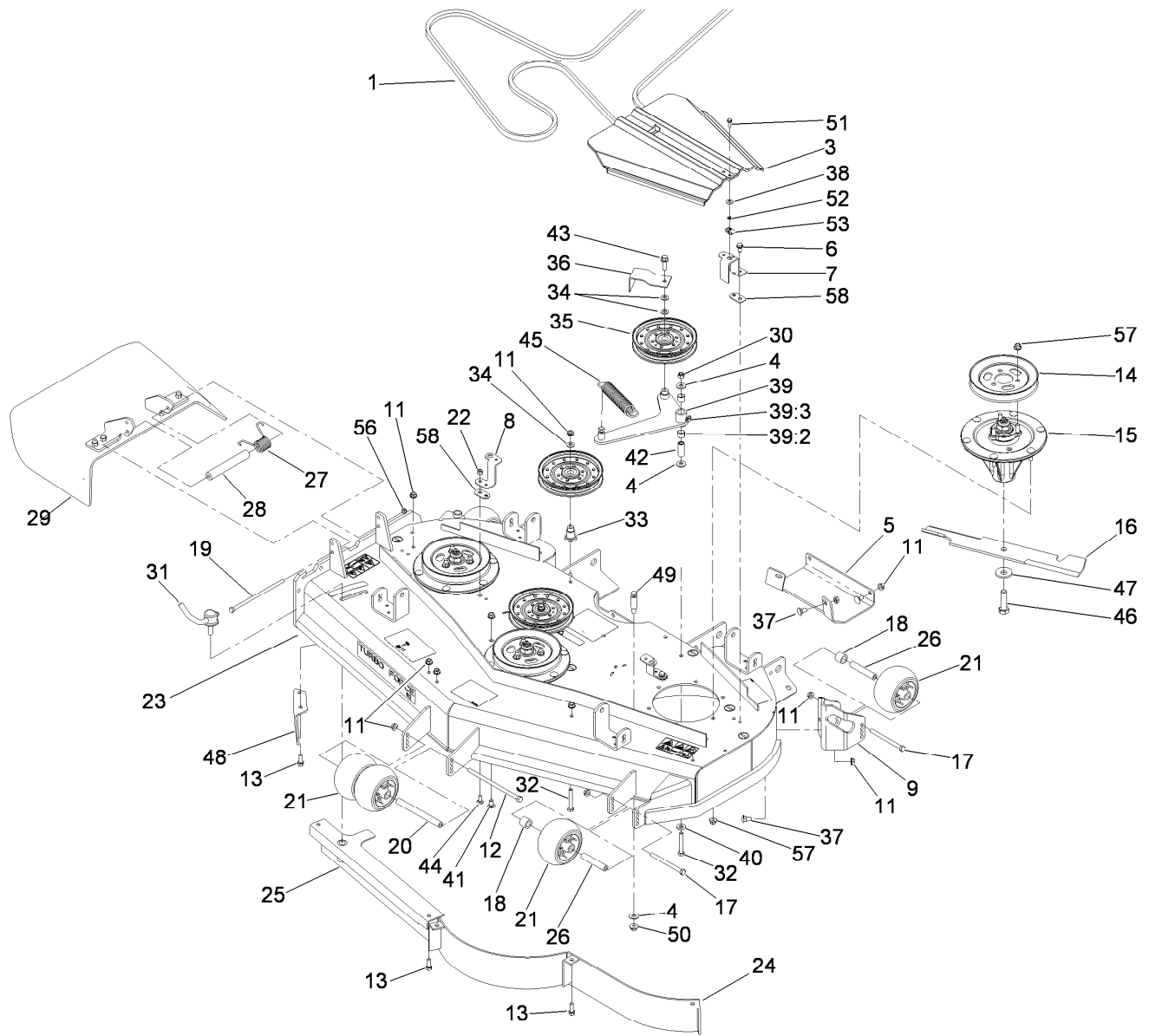

Deck Assembly

Ref.	Part Number	Qty.	Description	Ref.	Part Number	Qty.	Description
1	108-5951	1	Belt-V	24	105-7754-01	1	Baffle ASM
3	107-8536	2	Cover-Belt	25	105-7755-01	1	Baffle ASM
4	3256-4	3	Washer-Flat	26	98-7912	3	Tube-Spanner
5	106-7358-01	1	Plate-Skid	27	108-4052	1	Spring-Torsion
6	32144-70	3	Screw-HWHTF	28	105-4622	1	Spacer
7	108-4121-01	2	Bracket-Cover	29	108-2792	1	Rubber Deflector ASM
8	108-2177-01	2	Bracket-Cover, Tall	30	3296-39	1	Nut-Lock, NI
9	106-7354-01	1	Mount-Wheel, LH	31	107-1664	1	Lever ASM
11	3290-357	24	Nut-HHF, Whiz	32	323-12	3	Screw-HH
12	108-5388	1	Screw-HH	33	106-3214	2	Mount-Pulley
13	92-1624	6	Screw-HWH	34	3256-24	4	Washer-Flat
14	108-5979	3	Pulley-B Section	35	1-633109	3	Idler-Flat
15	117-6159	3	Spindle ASM	36	108-7220-01	1	Guide-Belt
16	105-7781-03	3	Blade-18 Inch (Hi Flow)	37	3231-1	11	Screw-CARR
17	323-23	3	Screw-HH	38	73-0041	2	Washer-Thrust
18	98-7913	3	Tube-Spacer	39	108-5949	1	Deck Idler Arm ASM
19	322-50	1	Screw-HH	39:2	103-4681	2	Sleeve-Bearing
20	98-5967	1	Spacer-Wheel	39:3	302-40	1	Fitting-Grease
21	1-603299	5	Roller-Scalp, Anti	40	98-5975	1	Washer-Belleville
22	3296-29	1	Nut-Lock, NI	41	3231-21	1	Screw-CARR
23	114-4487	1	Deck Decal ASM	42	1-603044	1	Bushing

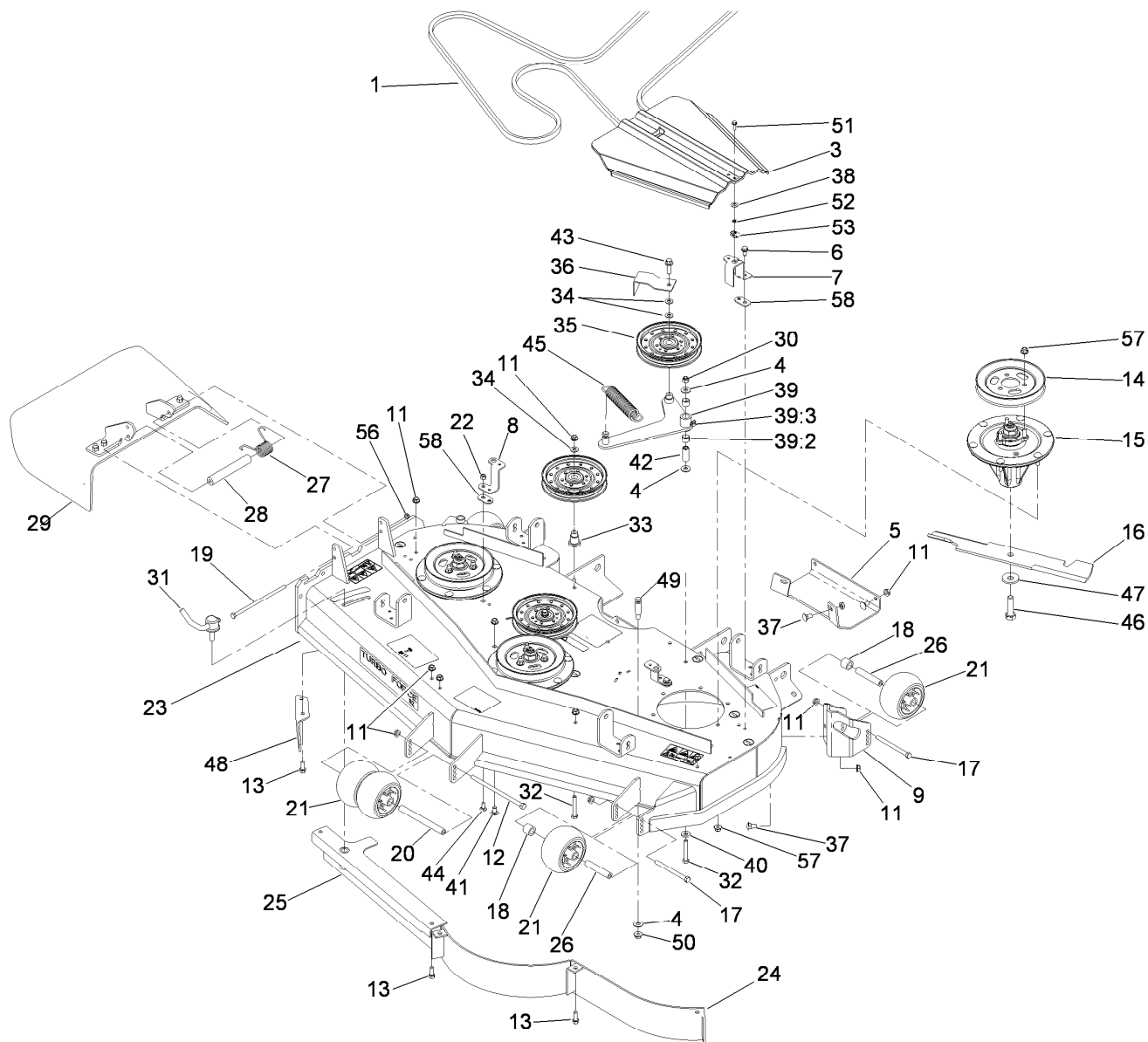

Deck Assembly (continued)

<i>Ref.</i>	<i>Part Number</i>	<i>Qty.</i>	<i>Description</i>	<i>Ref.</i>	<i>Part Number</i>	<i>Qty.</i>	<i>Description</i>
43	3234-24	1	Screw-HHF	50	32128-19	1	Nut-HF
44	3230-23	1	Screw-CARR	51	32105-15	2	Screw
45	110-0822	1	Spring-Extension	52	106-8737	2	Nut-Retainer
46	51-4060	3	Screw-Blade	53	107069	2	Clip
47	103-0865	3	Washer-Blade Bolt, Heavy	56	3296-47	1	Nut-Lock, NI
48	106-3216-01	1	Baffle-Discharge	57	104-8301	27	Nut-Flange, NI
49	110-0801	1	Pin-Threaded, Spring Anchor	58	119-4222-01	4	Spacer-Belt Cover

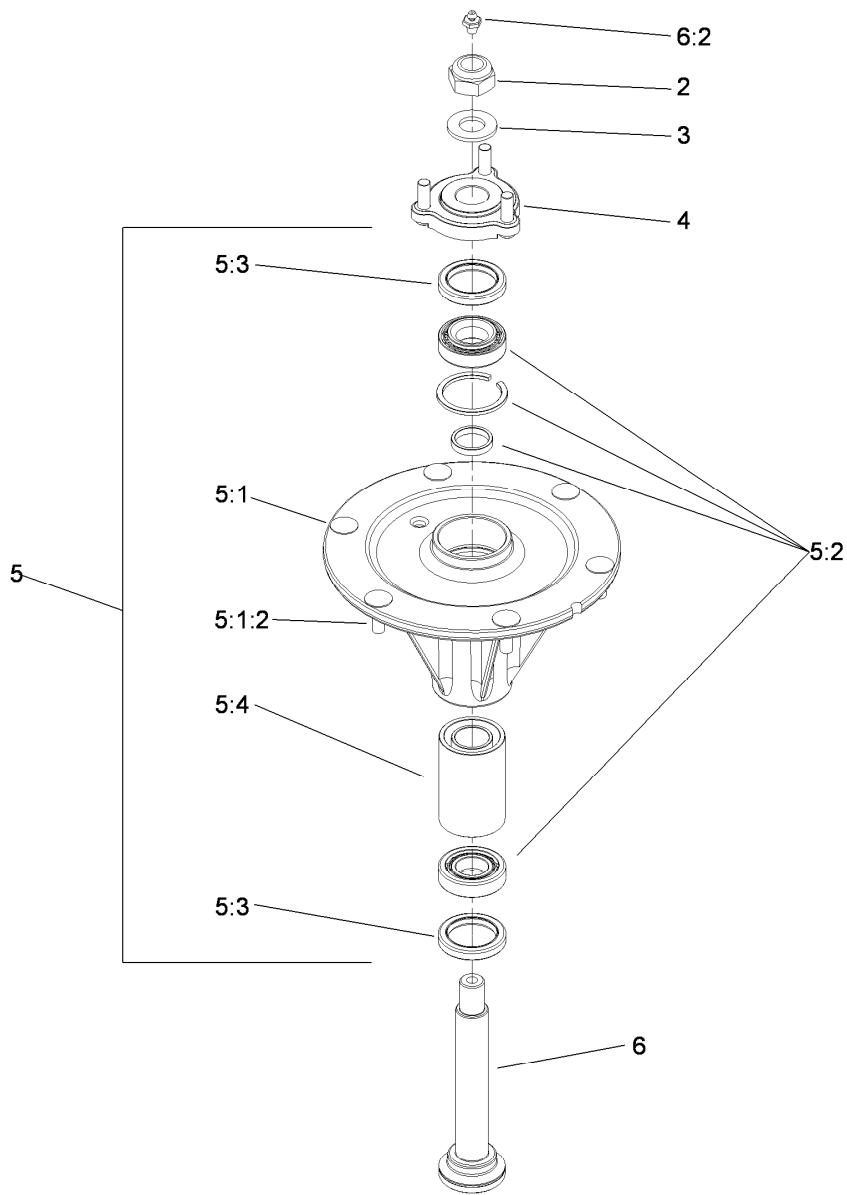

Spindle Assembly No. 117-6159

Ref.	Part Number	Qty.	Description
2	3296-67	1	Nut-Lock, NI
3	92-5836	1	Washer
4	117-6172	1	Spindle Hub ASM
5	117-6156	1	Spindle Housing And Tapered Bearings ASM
5:1		1	Trb Spindle Housing ASM W/Studs ●
5:1:2	114-8195	6	Bolt-Ribbed Neck
5:2	114-8163	1	Bearing ASM
5:3	253-133	2	Seal-Oil
5:4	117-6185	1	Spacer Set
6	119-1851	1	Spindle Shaft And Zerk ASM
6:2	302-2	1	Fitting-Grease

● Not serviced separately

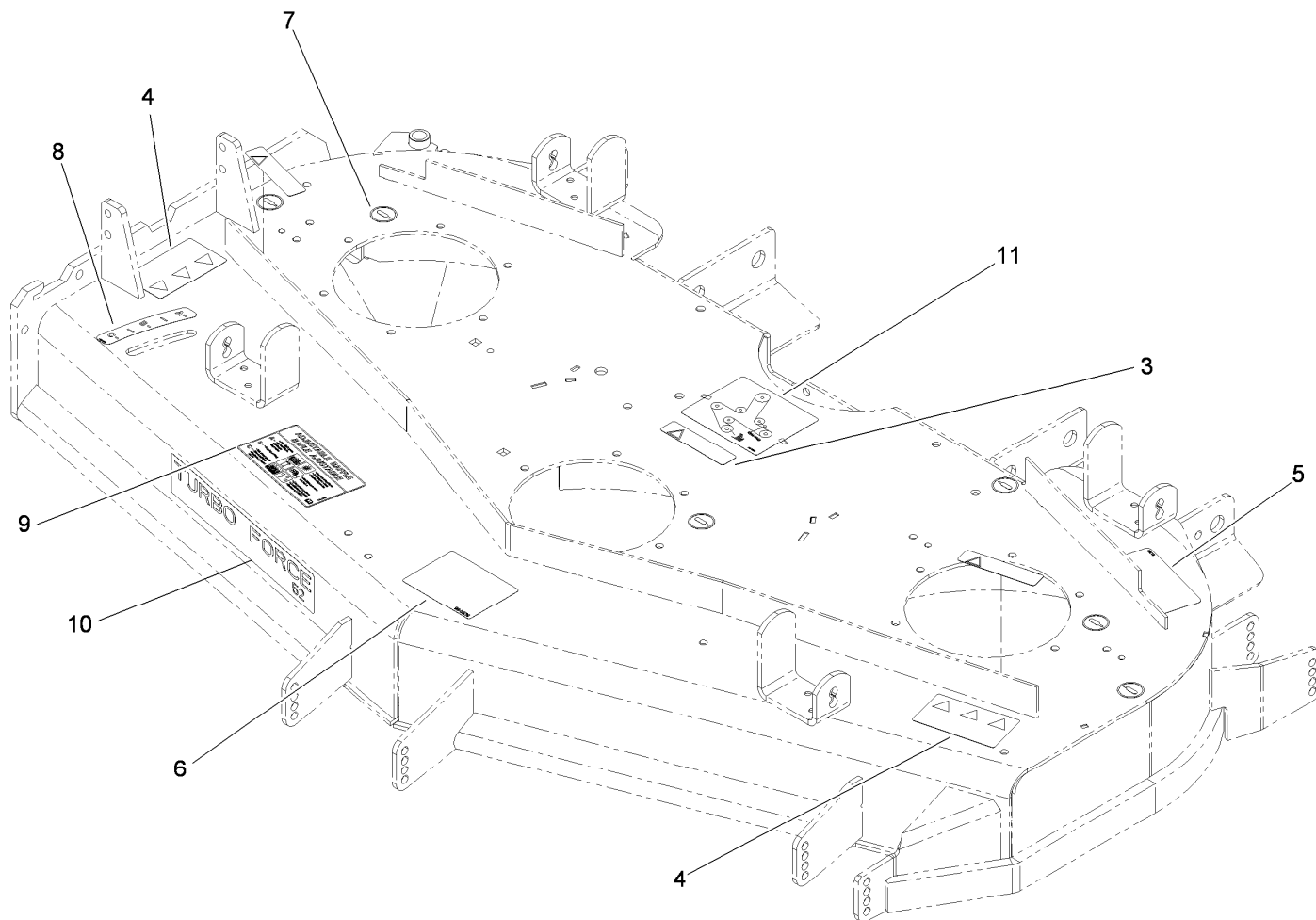

Deck Decal Assembly No. 114-4487

<i>Ref.</i>	<i>Part Number</i>	<i>Qty.</i>	<i>Description</i>
3	98-1977	3	Decal-Warning
4	93-7010	2	Decal-Danger
5	93-7818	1	Decal-Torque, Blade Bolt
6	99-8939	1	Decal-Anti Scalp
7	58-6520	6	Decal-Grease
8	110-2067	1	Decal-Setting, Baffle
9	110-2068	1	Decal-Adjustment, Baffle
10	107-1618	1	Decal
11	108-5981	1	Decal-Routing, Belt

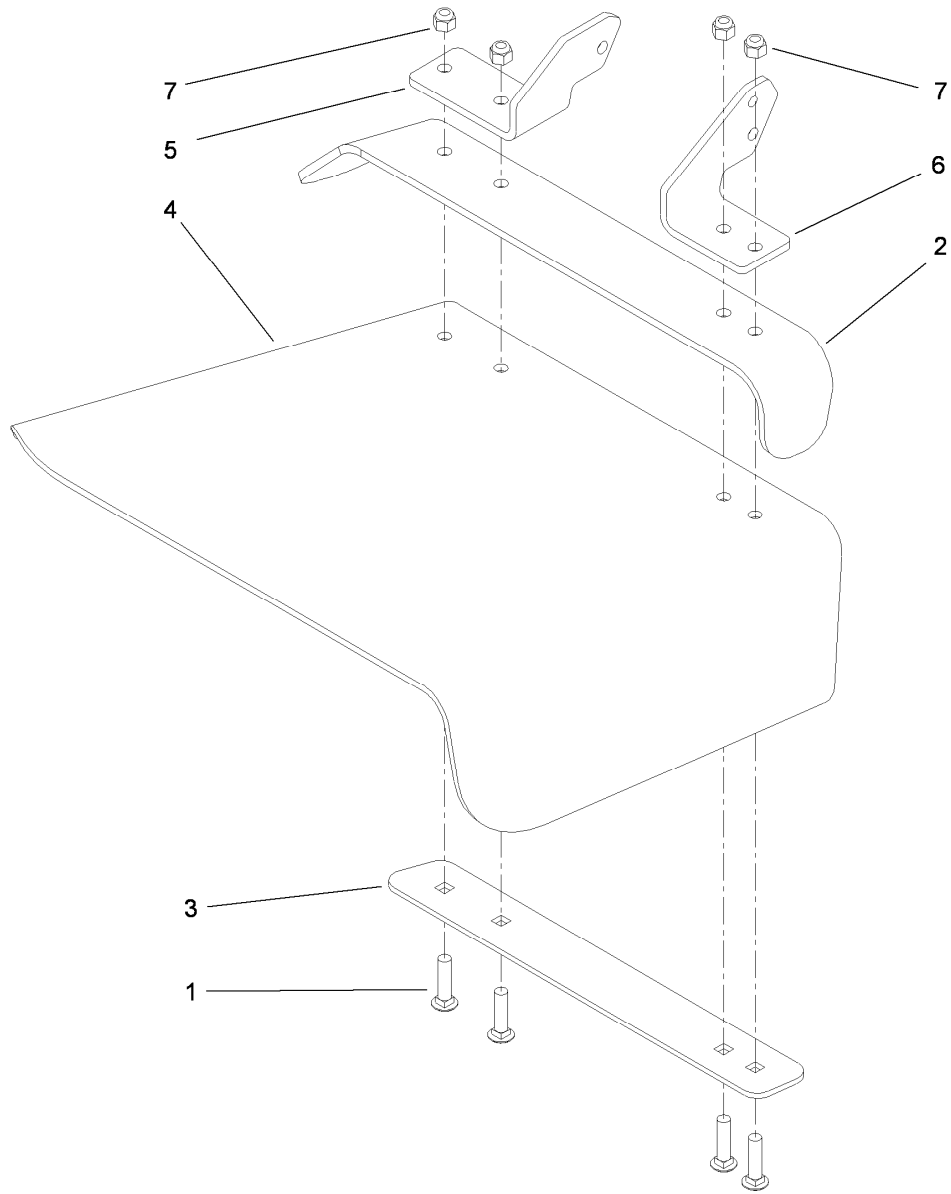

Rubber Deflector Assembly No. 108-2792

<i>Ref.</i>	<i>Part Number</i>	<i>Qty.</i>	<i>Description</i>
1	3231-4	4	Screw-CARR
2	106-3246-01	1	Deflector
3	106-3248-03	1	Strap-Discharge
4	108-5029	1	Deflector-Rubber
5	108-4059-01	1	Plate-Hinge, Rear
6	106-3253-01	1	Plate-Hinge, Front
7	3296-39	4	Nut-Lock, NI

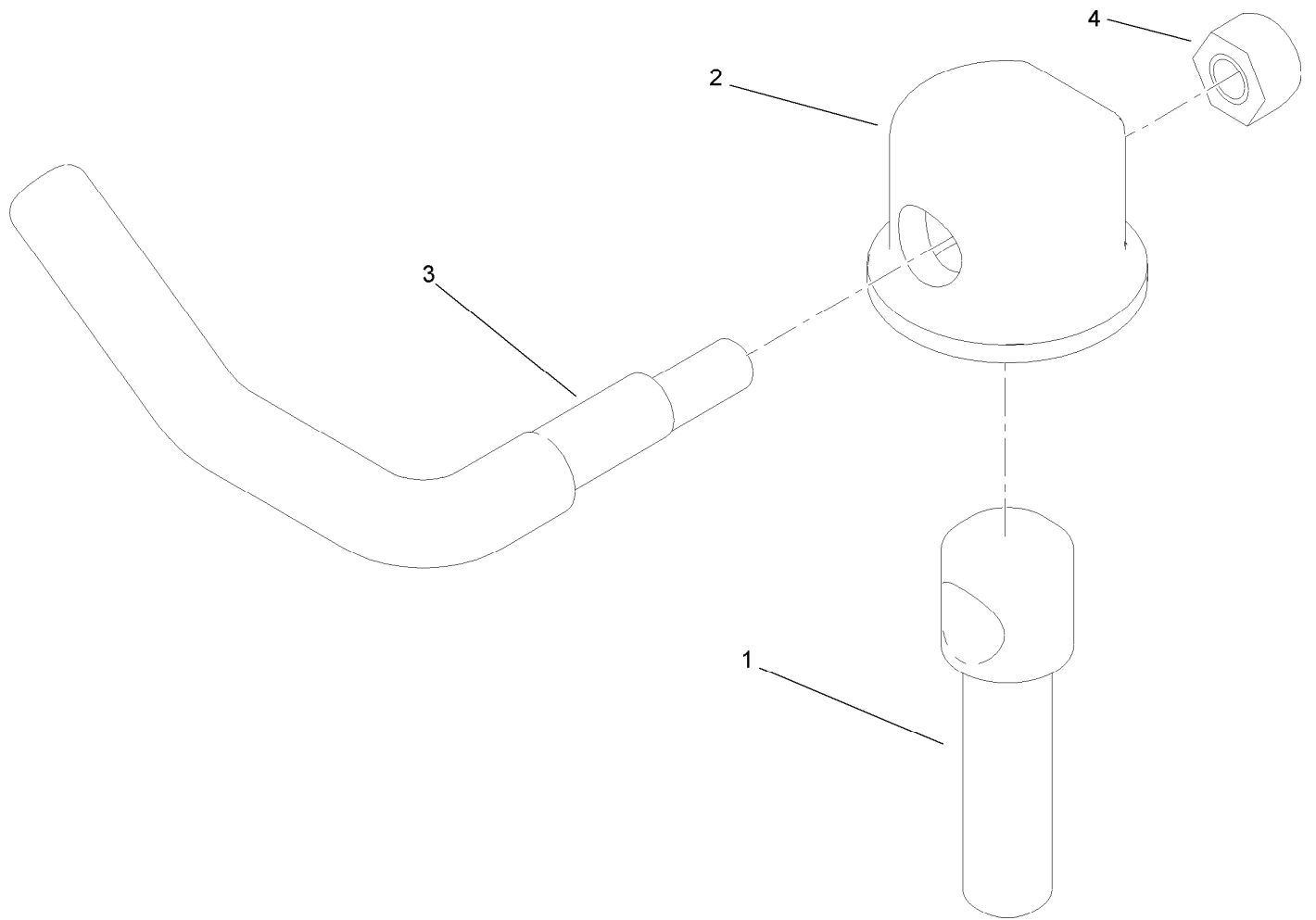

Lever Assembly No. 107-1664

<i>Ref.</i>	<i>Part Number</i>	<i>Qty.</i>	<i>Description</i>
1	106-3239	1	Screw-Lock
2	107-1644	1	Cap-Lock
3	106-3241	1	Lever-Lock
4	3296-29	1	Nut-Lock, NI

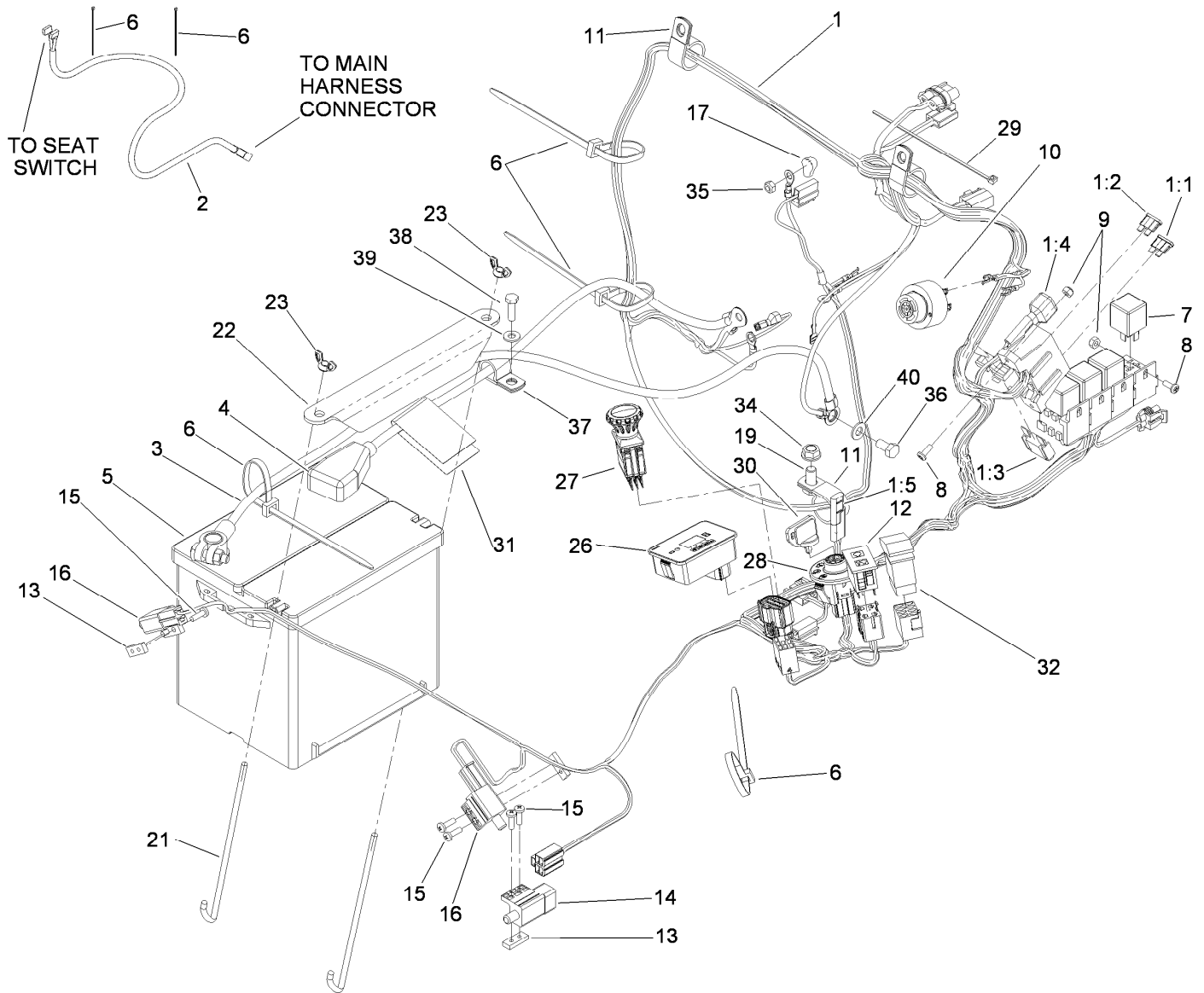

Electrical Assembly

Ref.	Part Number	Qty.	Description	Ref.	Part Number	Qty.	Description
1	119-0351	1	Harness-Wire	17	1-643178	1	Cap-Insulator, Red
1:1	218-578	1	Fuse-Blade, 10 Amp	19	323-4	1	Screw-HH
1:2	109103	1	Fuse-Blade, 30 Amp	21	103-1312	2	Bolt-Holddown
1:3	94-8002	1	Fuse-Blade, 50 Amp	22	103-1311-03	1	Holddown-Battery
1:4	100-4918	1	Diode	23	1-543792	2	Wingnut
1:5	116-0053	1	Cap-Plug	26	112-8650	1	Hour Meter ASM
2	103-1227	1	Harness-Wiring, Seat	27	116-0124	1	Switch-PTO, 10A
3	110-0303	1	Cable-Battery, Negative	28	117-2221	1	Switch-Ignition
4	110-0304	1	Cable-Battery, Positive	29	1-303287	1	Tie-Cable
5	106-5187	1	Battery	30	63-8360	2	Key-Ignition
6	1-303335	7	Tie-Plastic	31	107-9309	1	Decal-Instructions, Charging
7	1-643275	4	Relay	32	110-0811	1	Switch-Rocker
8	1-803071	4	Screw	34	3290-357	1	Nut-HHF, Whiz
9	3296-2	4	Nut-Lock, NI	35	33023-00	1	Nut-Lock
10	103-0205	1	Alarm-Tone, Dual	36	33114-016	1	Screw-HH
11	1-643312	3	Clip-Loom	37	1-633396	2	Clip-Loom
12	100-8071	1	Lamp-Warning	38	321-5	2	Screw-HH
13	1-633181	3	Plate-Tapped	39	3256-22	2	Washer-Flat
14	1-633111	1	Switch	40	3256-23	1	Washer-Flat
15	3290-500	6	Screw-PPH				
16	1-513051	2	Switch-Open, Normally				

Attachments and Accessories

For 74264TE Z580-D Z Master, With 132cm TURBO FORCE Side Discharge Mower

Product Name	Model/Part
1.25 Inch Spark Arrester Kit.....	105-1672
Blade-Recycler, 18 inch.....	105-7779-03
Blade-Hi Flow, 18 Inch.....	105-7781-03
Blade-Med Flow, 18 inch.....	105-7794-03
Blade-Low Flow, 18 inch.....	105-7795-03
Blade-Atomic, 18 inch.....	105-7796-03
Recycler Kit.....	107-1610
Striping Kit.....	107-1630
Turbo Baffle Kit.....	107-1634
Light Kit.....	107-9880
Blade-Hi Flow, 18 inch (6 Pack).....	108-1117
Blade-Atomic, 18 inch (6 Pack).....	108-1118
Roller Striping Kit.....	108-2162
Blade-Lo Flow, 18 inch (6 Pack).....	110-0406
Blade-Recycler, 18 inch (6 Pack).....	110-0408
Blade-Med Flow, 18 inch (6 Pack).....	110-0409
DFS Vac Collection System Mounting Kit.....	110-0891
DFS Pulley Kit.....	110-3944
DFS Bagger Gusset Kit.....	110-3946
Hypr-Oil 500 (quart).....	114-4713
Hypr-Oil 500 (gallon).....	114-4714
Hypr-Oil 500-5 (5 gallon).....	114-4715
Bimini Folding Shade Assembly.....	115-4510
Vac Collection System.....	78514
Chute Gate Kit.....	78521
Filter Minder Gauge.....	99-4664
Hitch Kit.....	99-8925



Count on it.