

For Serial Nos.  
600,000 & Higher

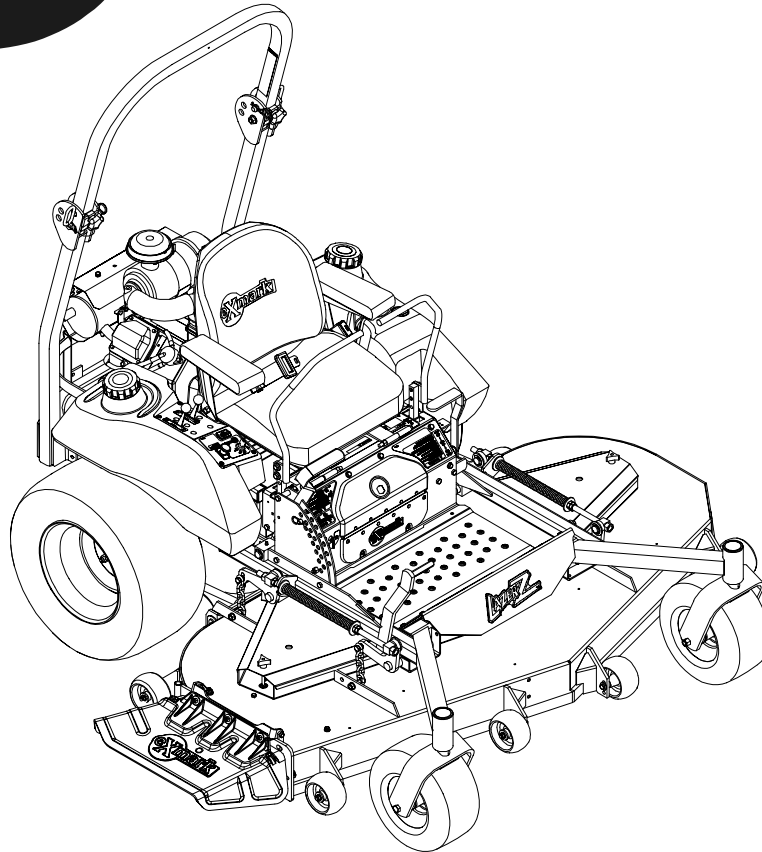

PARTS MANUAL

# LAZER Z<sup>®</sup>

## AIR-COOLED MODELS

**CONGRATULATIONS** on the purchase of your new Exmark mower. This product has been carefully designed and manufactured to give you a maximum amount of dependability and years of trouble-free operation. If additional information is needed, or should you require trained mechanic service, contact your authorized Exmark equipment dealer or distributor. If you need to order replacement parts from your dealer, always give the model number and serial number of your mower as well as the part number, description and quantity of the part needed.

The Serial No. plate is located on the right side of the console. For ease of ordering and reference, we suggest that you record the information requested in the following identification table.

Place Model No. and Serial No. Label Here (Included in Literature Pack) or Fill in Below
Model No. _____
Serial No. _____

Engine Model No. and Spec. No. (Code) \_\_\_\_\_

Engine Serial No. (E/No) \_\_\_\_\_

Date Purchased \_\_\_\_\_

# EXMARK PARTS PLUS® PROGRAM

EFFECTIVE DATE: September 1, 1995

## Program

If your Exmark dealer does not have the Exmark part in stock, Exmark will get the parts to the dealer the next business day or the part will be FREE\* Guaranteed!!

## *How the Program Works*

1. If dealer does not have part in stock for a "down" unit at the time of request by customer, the dealer contacts his distributor by 1:00 p.m., local time, and requests Exmark Parts Plus® shipment of six (6) line items or less.
2. Distributor ships part(s) to dealer or customer, as requested by dealer, same day, overnight UPS. Distributor bills dealer for part and freight charges where applicable.
3. If distributor does not have the part(s) in stock to satisfy Exmark Parts Plus® order, he contacts Exmark by 3:00 p.m., central time, with an Exmark Parts Plus® order of six (6) line items or less.
4. If order is received by 3:00 p.m. central time, Exmark ships part(s) direct to dealer or customer, as requested by distributor, same day, overnight UPS. Exmark bills the distributor for parts and shipping charges, where applicable.
5. The customer pays for the part and freight if it is shipped under the Exmark Parts Plus® and if it arrives in accordance to the program.
6. Who pays for the part and freight if it fails to arrive overnight in accordance to the program?
  - A. Under any circumstance the customer does not pay.
  - B. If the part does not arrive overnight due to:
    1. The dealer not submitting the Exmark Parts Plus® order to his Exmark distributor by 1:00 p.m., the dealer pays for the part and freight.
    2. The Distributor being unable to ship the part the same day or not submitting the Exmark Parts Plus® order to Exmark by 3:00 p.m., central time, the Distributor pays for the part and freight.
    3. Exmark being unable to ship the part and the Exmark parts order is received by 3:00 p.m., central time, Exmark pays for the part and freight.
    4. If the part does not arrive overnight due to the shipper (UPS), the shipper pays for the freight and Exmark pays for the part.

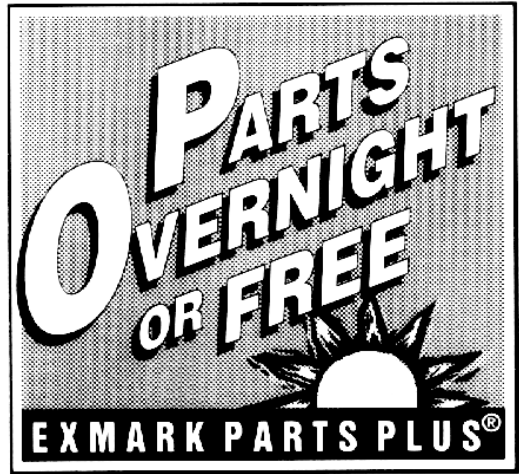

**The following restrictions apply** -- The Exmark Parts Plus® Program is available only through participating Exmark Dealers and applies only to orders submitted on this program Monday through Thursday. Parts Plus service is available only in the 48 contiguous United States. UPS has initiated a Saturday delivery program to many areas of the continental United States and can be requested for an overnight shipment on Friday to be delivered Saturday. The next day air charge, plus the Saturday delivery fee will be the responsibility of the purchaser. Exmark Mfg. will assume no responsibility for Saturday delivery shipments. To qualify, all Exmark Parts Plus® orders must be received by Exmark by 3:00 p.m., central time. Orders must be six (6) line items or less. Exclusions from the Exmark Parts Plus® Program are: Any wholegood or accessory in its entirety, engines and engine replacement parts, 5-speed Peerless transmissions and 5-speed transaxles, hydraulic or hydrostatic wheel motors, cutter decks and engine decks or any item exceeding United Parcel Service size and weight restrictions.

Due to UPS restrictions, aerosol spray paint is considered a hazardous material and cannot be shipped via UPS next day or Second Day Air.

Exmark Manufacturing stocks a limited supply of parts for transaxles, pumps and wheel motors. These parts can be ordered for Next Day Air shipment but will not be guaranteed per the Parts Plus Program.



**READ OPERATOR'S MANUAL BEFORE  
OPERATING OR SERVICING EXMARK EQUIPMENT.**

## **TABLE OF CONTENTS**

<b><u>Description</u></b>	<b><u>Page</u></b>
Deck Group.....	3-5
Decal Group.....	21-22
Electrical Diagrams .....	25-26
Electrical Groups.....	23-24
Electrical Logic Schematics.....	27-28
Engine Deck Group.....	16-18
Front Frame Group .....	7-8
Fuel Groups .....	11-12
Hydraulics Group .....	19-20
Main Frame Group.....	9-10
Motion Control Group.....	15
Park Brake Group .....	13-14
Spindle Assembly .....	6

## DECK GROUP

Item	Part No.	Description	Qty.
1	1-303334	Washer, Spring Disk 5/16.....	1
2	1-303537	Stud, Belt Shield .....	2
3	1-322110	Wld, Belt Guide .....	1
4	1-323385	Knob .....	2
5	1-323417	Washer, Belt Shield.....	2
6	1-603805	Sheave, Idler.....	1
7	1-633109	Sheave, Flat Idler.....	2
8	1-633456	Bushing, Idler.....	2
9	98-5961	Screw, HH 3/8-16 x 4 Gr8 .....	1
10	98-5975	Washer, Spring Disk 3/8.....	3
11	103-2916	Guard, Top.....	1
12	103-3330	Spring .....	1
13	103-3504	Bearing, Spherical.....	2
14	103-3505	Seal, Double Lip.....	1
15	103-3506	Seal, Single Lip.....	1
16	103-5677	Spacer .....	1
17	103-8103-01	Latch, Belt Shield.....	2
18	109-2097	Asm, Shield W/Decal 60" RH .....	1
	109-2133	Asm, Shield W/Decal 66" RH .....	1
	109-2135	Asm, Shield W/Decal 72" RH .....	1
19	109-2096	Asm, Shield W/Decal 60" LH.....	1
	109-2132	Asm, Shield W/Decal 66" LH.....	1
	109-2134	Asm, Shield W/Decal 72" LH.....	1
20	105-7699	Strip-Seal, 3".....	4
21	106-7159	O-Ring.....	2

Item	Part No.	Description	Qty.
22	109-2100	Asm, Deck W/Decals 60" .....	1
	109-2103	Asm, Deck W/Decals 66" .....	1
	109-2105	Asm, Deck W/Decals 72" .....	1
23	1-633127	Belt 60".....	1
	109-0775	Belt 66".....	1
	1-643052	Belt 72".....	1
24*	109-2095	Kit, Idler Arm W/Bearings.....	1
25	302-40	Zerk, 90° 1/4-28.....	1
26	322-6	Screw, HH 5/16-18 x 1 1/4.....	1
27	323-11	Screw, HH 3/8-16 x 2 1/4.....	2
28	3230-18	Bolt, Carriage 5/16-18 x 5/8 .....	9
29	3230-16	Bolt, Carriage 5/16-18 x 7/8 .....	2
30	3234-11	Screw, HH FLG 3/8-16 x 1 .....	1
31	3256-23	Washer, 5/16 SAE .....	2
32	3256-24	Washer, 3/8 SAE .....	3
33	3256-3	Washer, 5/16 Std.....	6
34	3256-4	Washer, 3/8 Std.....	2
35	3290-357	Nut, Whizlock 3/8-16.....	2
36	3296-29	Nut, Nyloc 5/16-18 .....	2
37	3296-39	Nut, Nyloc 3/8-16 .....	1
38	32120-10	Ring, Retaining .....	2
39	32128-20	Nut, Whizlock 5/16-18.....	12
40▲	109-2101	Asm, Deck Complete 60".....	1
	109-2104	Asm, Deck Complete 66".....	1
	109-2106	Asm, Deck Complete 72".....	1

Exmark red touch up paint (spray paint - P/N 1-850337 - .6 oz liquid bottle - P/N 103-9140).

- ▲ Complete deck assembly includes all items from pages 3 – 6 except items ( #8, #16, #28, #31,#38, and #40 from page 5) and includes mule drive belt from page 16.
- \* Kit also includes items #10 & #37.

# DECK GROUP

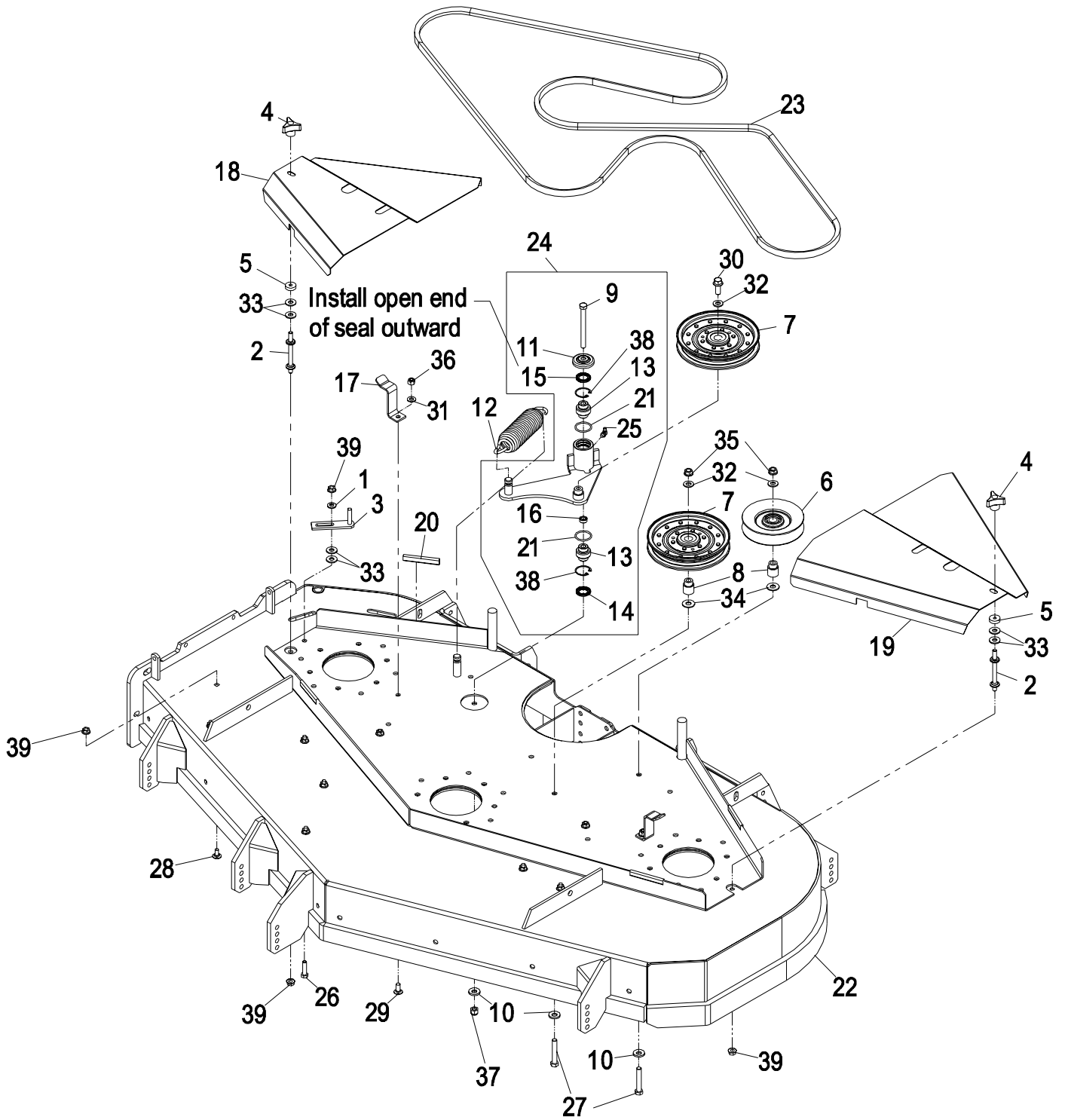

## DECK GROUP (cont.)

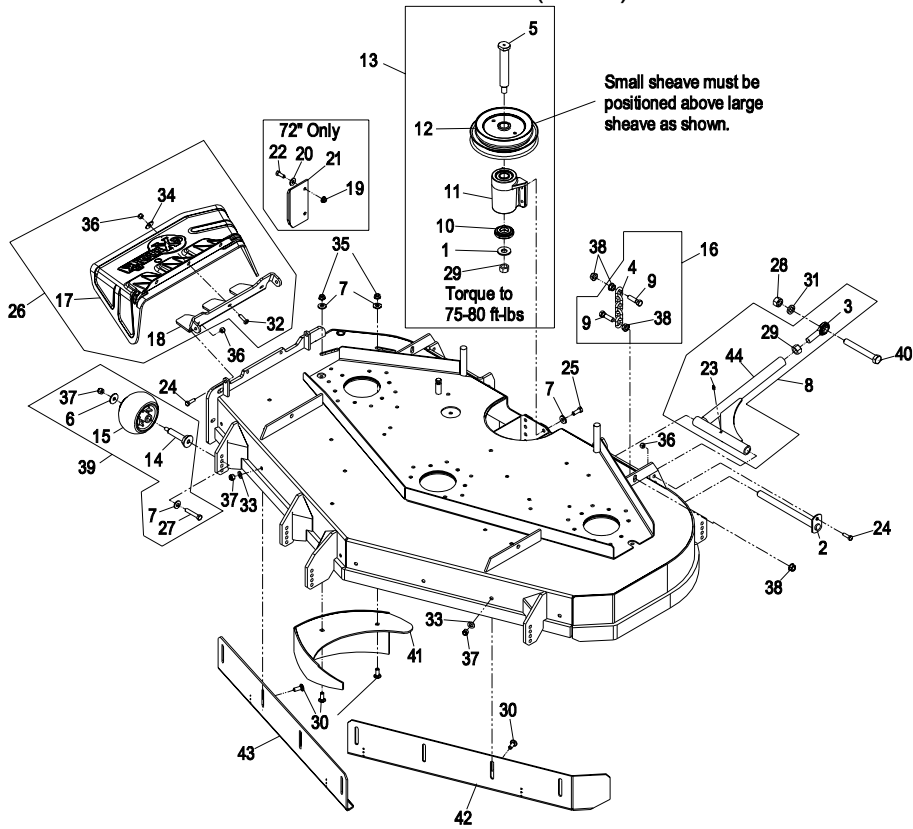

Item	Part No.	Description	Qty.
1	1-513208	Washer, Spring Disk 5/8.....	1
2	1-632199-01	Wld, Pin Deck Strut.....	2
3	1-633029	Balljoint.....	2
4	1-633447	Chain, Deck Lift.....	4
5●	1-643393	Jackshaft, Lazer.....	1
6	63-8410	Washer.....	6
7	98-5975	Washer, Spring Disk 3/8.....	12
8	103-1081	Asm, Strut 60".....	2
	103-1083	Asm, Strut 66" & 72".....	2
9	103-1898	Screw, HH 7/16-20 x 1-5/8 Sp.....	8
10	103-2535	Spacer, Guard Bottom.....	1
11●	103-2544	Asm, Jackshaft Housing.....	1
12●	103-3046	Sheave, Jack Shaft- Double.....	1
13	103-3249	Asm, Jackshaft.....	1
14	103-5364	Axle, Anti-Scalp Roller.....	6
15	103-8415	Roller, Anti-Scalp.....	6
16	103-9792	Asm, Chain Deck.....	4
17	109-0497	Chute, Discharge LZ.....	1
18	109-0498-03	Hinge, Grass Discharge.....	1
19	32128-20	Nut, Whizlock 5/16-18 72".....	2
20	3256-3	Washer, 5/16 Std 72".....	2
21	103-9423-01	Deflector, Discharge 72".....	1
22	322-4	Screw, HH 5/16-18 x 7/8 72".....	2
23	302-19	Zerk, 1/4-28 Str.....	4
24	322-5	Screw, HH 5/16-18 x 1.....	4
25	323-6	Screw, HH 3/8-16 x 1.....	4
26	109-2099	Asm, Discharge Chute.....	1

Item	Part No.	Description	Qty.
27	3211-46	Screw, HH 3/8-24 x 2 Gr8.....	6
28	3217-11	Nut, Hex 5/8-11.....	2
29	3219-6	Nut, Hex 5/8-18.....	3
30	3231-22	Bolt, Carriage 3/8-16 x 1.....	10
31	3253-8	Washer, Lock 5/8.....	2
32	3230-16	Bolt, Carriage 5/16-18 x 7/8.....	3
33	3256-24	Washer, 3/8 SAE.....	8
34	3256-82	Washer.....	3
35	3290-357	Nut, Whizlock 3/8-16.....	2
36	3296-29	Nut, Nyloc 5/16-18.....	7
37	3296-39	Nut, Nyloc 3/8-16.....	14
38	32128-37	Nut, Whizlock 7/16-14.....	16
39	109-2098	Kit, Anti-Scalp Roller.....	6
40	327-11	Screw, HH 5/8-11 x 5 60".....	2
	327-28	Screw, HH 5/8-11 x 5 1/2 66" & 72".....	2
41	109-0694-01	Wld, Dogleg 60".....	1
	109-0821-01	Wld, Dogleg 66".....	1
	109-1039-01	Wld, Dogleg 72".....	1
42	109-0701-01	Wld, Baffle Front Adj LH 60".....	1
	109-0822-01	Wld, Baffle Front Adj LH 66".....	1
	109-1044-01	Wld, Baffle Front Adj LH 72".....	1
43	109-0704-01	Wld, Baffle Front Adj RH 60".....	1
	109-0823-01	Wld, Baffle Front Adj RH 66".....	1
	109-1047-01	Wld, Baffle Front Adj RH 72".....	1
44	103-1072-01	Wld, Deck Strut-Std 60".....	2
	103-1073-01	Wld, Deck Strut-Std 66" & 72".....	2

Exmark red touch up paint (spray paint - P/N 1-850337 - .6 oz liquid bottle - P/N 103-9140).

- Apply Mobil HTS grease (P/N 103-5217 1.5 oz packet) (or a food-grade antiseize) between the jackshaft and bearings and jackshaft and sheaves. DO NOT use a copper or nickel based antiseize.

# SPINDLE ASSEMBLY

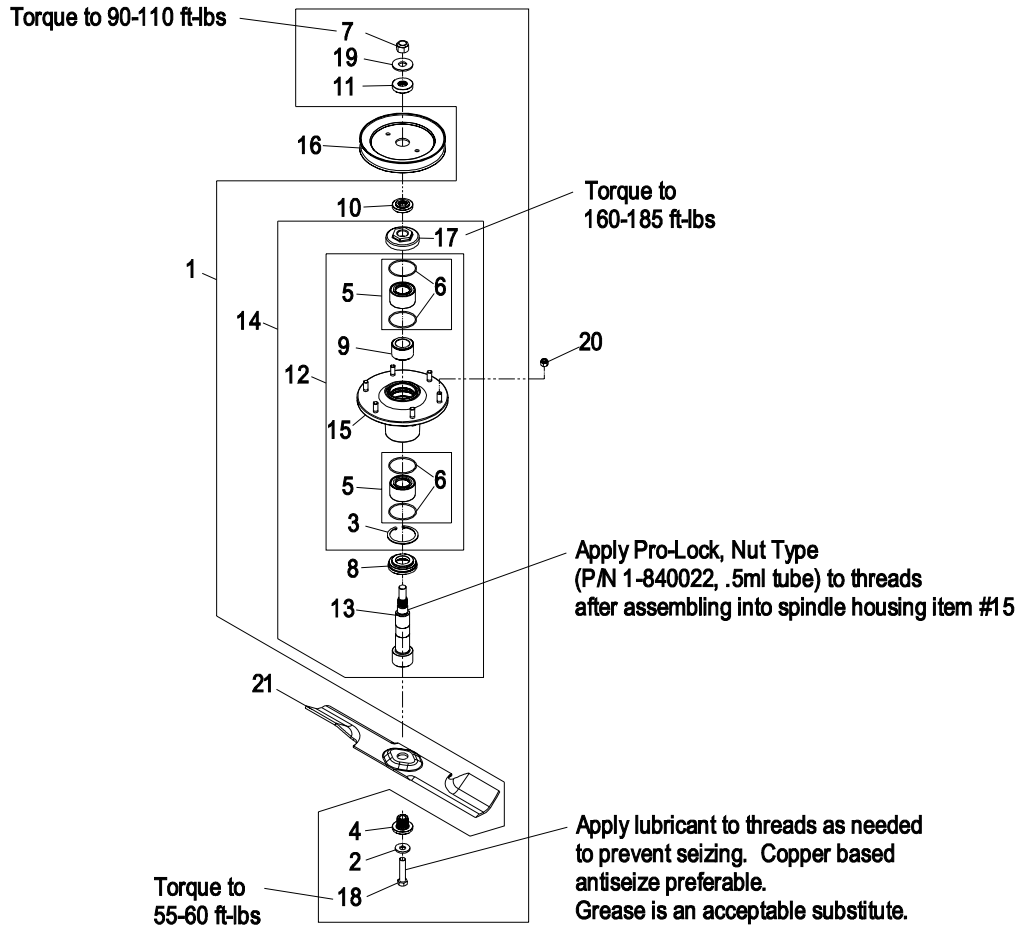

Item	Part No.	Description	Qty.
1	109-2102	Asm, Cutter Housing Complete .....	3
2	1-513435	Washer, Spring Disk 1/2.....	3
3	92-5581	Retaining Ring, Internal.....	3
4	103-3037	Bushing, Splined .....	3
5	109-2064	Asm, Bearing W/O-Rings .....	6
6	103-5895	O-Ring .....	12
7	3296-41	Nut, Nyloc 5/16-18 .....	3
8	103-9504	Guard, Bottom.....	3
9	103-9506	Spacer, Bearing .....	3
10	103-9522	Spacer, Splined Stepped.....	3
11	103-9523	Spacer, Splined.....	3
12	103-9539	Asm, Cutter Housing.....	3
13●	103-9540	Spindle, Double Spline .....	3
14	103-9541	Asm, Spindle Housing.....	3
15	109-0764	Asm, Housing W/Studs .....	3
16	109-0914	Sheave, Blade Drive 60" .....	3
	109-0929	Sheave, Blade Drive 66" .....	3
	109-1005	Sheave, Blade Drive 72" .....	3
17	109-1058	Nut, Spindle 7/8-14 .....	3
18	3213-6	Screw, HH 1/2-20 x 2 1/4 .....	3
19	3256-7	Washer, 5/8 Std .....	3
20	3296-39	Nut, Nyloc 3/8-16 .....	18

Item	Part No.	Description	Qty.
21	103-8240	Blade, Low Lift 60" .....	3
	103-8396	Blade, Medium Lift 60" .....	3
	103-8239	Blade, High Lift Solid 60" .....	3
	103-8244	Blade, High Lift Notched 60" .....	3
	103-8432	Blade, High Lift Ls 60" .....	3
	103-8431	Blade, High Lift Ls Solid 60" .....	3
	■ 103-8107	Blade, Mulch 60" .....	3
	103-9616	Blade, Low Lift 66" .....	3
	103-9619	Blade, Medium Lift 66" .....	3
	103-9617	Blade, High Lift Solid 66" .....	3
	103-9618	Blade, High Lift Notched 66" .....	3
	103-9620	Blade, High Lift Ls 66" .....	3
21	103-9621	Blade, High Lift Ls Solid 66" .....	3
	■ 103-9612	Blade, Mulch 66" .....	3
	103-9622	Blade, Low Lift 72" .....	3
	103-9625	Blade, Medium Lift 72" .....	3
	103-9623	Blade, High Lift Solid 72" .....	3
	103-9624	Blade, High Lift Notched 72" .....	3
	103-9626	Blade, High Lift Ls 72" .....	3
	103-9627	Blade, High Lift Ls Solid 72" .....	3
	■ 103-9613	Blade, Mulch 72" .....	3

Exmark red touch up paint (spray paint - P/N 1-850337 - .6 oz liquid bottle - P/N 103-9140).

■ Requires installation of Micro-Mulch accessory for proper mulching. Mulch kit P/N MK605 (60"), MK665 (66"), and MK725 (72").

● Apply Mobil HTS grease (P/N 103-5217 1.5 oz packet) (or a food-grade antiseize) between the spindles and bearings. DO NOT use a copper or nickel based antiseize.

## FRONT FRAME GROUP

Item	Part No.	Description	Qty.
1▲	109-2072	Asm, Front Frame, 60" .....	1
▲	109-2073	Asm, Front Frame, 66" .....	1
▲	109-2074	Asm, Front Frame, 72" .....	1
2	302-19	Zerk, 1/4-28 Straight .....	5
3	109-1903	Asm, Floorpan (103-8274-01) W/Decals .....	1
4	1-543509	Bearing Cone, Tapered Roller .....	4
5	103-2084	Asm, Lever (103-2083-03)W/Grip .....	1
6	1-633295	Grip, Lift Lever .....	1
7	103-9529-03	Arm Wldmt, Deck Lift .....	1
8	1-633325	Spring, Compression.....	1
9	3256-24	Washer, 3/8 SAE Flat.....	1
10	3296-39	Nut, Nyloc 3/8-16 .....	4
11	32151-103	E-Ring.....	5
12	1-633068	Arm, Deck Lift .....	2
13	1-633889-01	Plate, Deck Lift.....	1
14	108-7759-01	Wld, Deck Lift Plate.....	1
15	1-633082	Bushing, Lift Lever .....	1
16	103-8275	Stop, Deck Height .....	1
17	323-13	Screw, 3/8-16 x 2 3/4 .....	1
18	1-633097	Hitch Pin W/Lanyard .....	1
19	1-806005	Hairpin Cotter.....	1
20	323-9	Screw, 3/8-16 x 1 3/4 .....	2
21	98-5975	Washer, 3/8 Disc Spring.....	12
22	3290-357	Nut, Whizlock 3/8-16.....	15
23	323-6	Screw, 3/8-16 x 1 .....	1
24	323-7	Screw, 3/8-16x1 1/4 .....	12
25	3256-29	Washer, 7/8 SAE Flat.....	4
26	1-633096	Rod, Deck Lift .....	2
27	3217-11	Nut, 5/8-11 Regular.....	6
28	1-633441	Swivel, Deck Mount.....	4

Item	Part No.	Description	Qty.
29	3256-7	Washer, 5/8 Std Flat .....	4
30	1-643015	Spring, Deck Support.....	2
31	103-4882	Cap, Grease .....	2
32	3218-6	Jam Nut, 5/8-11 .....	6
33	109-1902	Asm, Floorpan, Liftout (103-8276-01) W/Decal.....	1
34	1-543511	Seal, Grease.....	2
35	103-1474-01	Caster Wldmt.....	2
36	3296-51	Nut, 3/4-10 Nyloc.....	2
37	1-633508	Washer, Spring Disk .....	6
38	325-39	Screw, 1/2-13 x 9 1/2.....	2
39	1-811010	Plug .....	2
40	103-2768	Guard, Seal .....	4
41	3296-23	Nut, 1/2-13 Nyloc.....	2
42	3230-1	Bolt, Carriage 5/16-18 x 3/4 .....	4
43	103-0063	Seal, Bearing.....	4
44	1-633585	Bearing Cone.....	4
45	32128-20	Nut, Whizlock 5/16-18.....	4
46	103-5156	Axle, Caster .....	2
47	103-1918	Bushing .....	2
48	323-29	Screw, 3/8-16 x 1 3/8.....	2
49	32151-29	Ring, Retaining .....	2
50	3274-18	Screw, Socket HD5/16-18x1 1/4 .....	2
51	1-543508	Bearing Cup, Tapered Roller .....	4
52+	103-3051	Spacer, Nut.....	4
53	103-3799	Asm, Caster Wheel (Semi-Pneumatic)...	2
54	3218-2	Jam Nut, 5/16-18 .....	2
55	103-9741-01	Weldmt, Front Lift Shaft (LH) .....	1
56	103-9740-01	Weldmt, Front Lift W/Lever(RH) .....	1
57	1-523157	Washer, Spacer.....	2
58	103-2047	Asm, Deck Lift Spring .....	2

Exmark red touch up paint (spray paint - P/N 1-850337 - .6 oz liquid bottle - P/N 103-9140).

✚ Use Pro-Lock, Nut Type (P/N 1-840022, .5ml tube) on spacer nut, Item #52.

▲ Includes frame weldment plus items #2, #31, #34, #39, #49, #51, #55, #56 and #57.



# MAINFRAME GROUP

Item	Part No.	Description	Qty.
1	1-643255	Track, Seat (4" Adjustable).....	1
	103-8386	Spring, Seat Rail .....	1
2●	103-3524	Seat .....	1
3	1-543401	Spacer, Seat Track .....	2
4	322-3	Screw, 5/16-18 x 3/4 .....	6
5	103-3521	Cushion, Seat .....	1
6	103-3520	Cushion, Backrest.....	1
7	103-0292	Cushion, Armrest (RH).....	1
8*	103-0291	Cushion Armrest (LH) .....	1
9	1-633859	Seat Frame .....	1
10	3256-3	Washer, 5/16 Std Flat .....	2
11	109-1906	Asm, Frame (103-9040-03) W/Decals ....	1
12	103-2743	Wheel/Tire Assy.....	2
	103-2744	Tire, 24x12-12 4 Ply.....	2
	1-633992	Wheel .....	2
13	109-2075	Asm, Console (103-8273-03) W/Decals .	1
14	103-4423	Asm, Seat Frame .....	1
15	242-50	Nut, Wheel 1/2-20 .....	8
16	1-633293	Rod, Seat Hold-Up.....	1
17	322-5	Screw, 5/16-18 x 1 .....	1
18	323-39	Screw, 3/8-16 x 5 .....	2
19	3296-2	Nut, Nyloc #10-24 .....	8
20	3296-29	Nut, Nyloc 5/16-18 .....	3
21	3296-39	Nut, Nyloc 3/8-16 .....	3
22	3290-357	Nut, Whizlock 3/8-16.....	10
23	32128-20	Nut, Whizlock 5/16-18.....	8
24	323-20	Screw, 3/8-16 x 3-1/4.....	1
25	3256-24	Washer, 3/8 SAE Flat.....	1
26	109-0665	Kit, Seat Belt.....	1
27	107-3083	Latch, Seat.....	1
28	322-4	Screw, 5/16-18 x 7/8 .....	2

Item	Part No.	Description	Qty.
29	1-513658	Bumper.....	2
30	3256-23	Washer, 5/16 SAE Flat .....	6
31	103-4434	Grip .....	1
32	323-6	Screw, 3/8-16 x 1.....	2
33	1-633964-03	Stop, Park Brake.....	1
34	103-8383	Bolt, Seat Cushion .....	5
35	106-0887	Knob (Type A) .....	2
36	322-7	Screw, 5/16-18 x 1 1/2.....	2
37	107-3124	Clip (Type A).....	2
38	3212-4	Screw, 7/16-20 x 1.00.....	2
39	3296-38	Nut, Nyloc 7/16-20.....	2
40■	103-4553	Asm, ROPS Fold Pin .....	2
41	107-0075	Bushing .....	1
42	107-0076	Spring.....	1
43	107-3058	Catch, Seat Latch .....	1
44	3256-14	Washer, #10 STD Flat .....	8
45	32122-28	Screw, Truss HD #10-24 x 1 .....	4
46	1-803075	Screw, Truss HD #10-24 x 3/4 .....	2
47	3290-500	Screw, Pan Head #10-24 x 5/8 .....	2
48	103-3790	Latch, Cubby Door.....	1
49	103-3666	Asm, Cubby .....	1
50	323-6	Screw, Hex Cap 3/8 x 1 .....	8
51	107-3154	Nut, Push 3/8-16 (Type A) .....	4
52	98-5975	Washer, Spring Disk 3/8 .....	8
53	107-3155	Cotter, Hair Pin Double Loop .....	2
54	32128-23	Nut, Hex Flange Side Lock 1/2-13 .....	2
55	325-13	Screw, 1/2-13 x 3 1/4.....	2
56	3296-73	Nut, Nyloc 1/4-20 (Type B).....	1
57	109-2365	Bumper (Type B) .....	1
58◆	103-8436	Kit, ROPS LZ .....	1

Exmark black touch up spray paint - gloss black.

\* Not illustrated.

■ Includes ROPS fold pin plus hairpin, item #53.

◆ Rollover protection frame is serviced as a complete assembly only. Includes complete ROPS frame, mounting hardware, fold pivot and locking hardware, seat frame assembly item #14, catch item #43, and seat belt assembly item #26.

● Includes armrests and seat back decal. Does not include seat belt or tracks.

# MAINFRAME GROUP

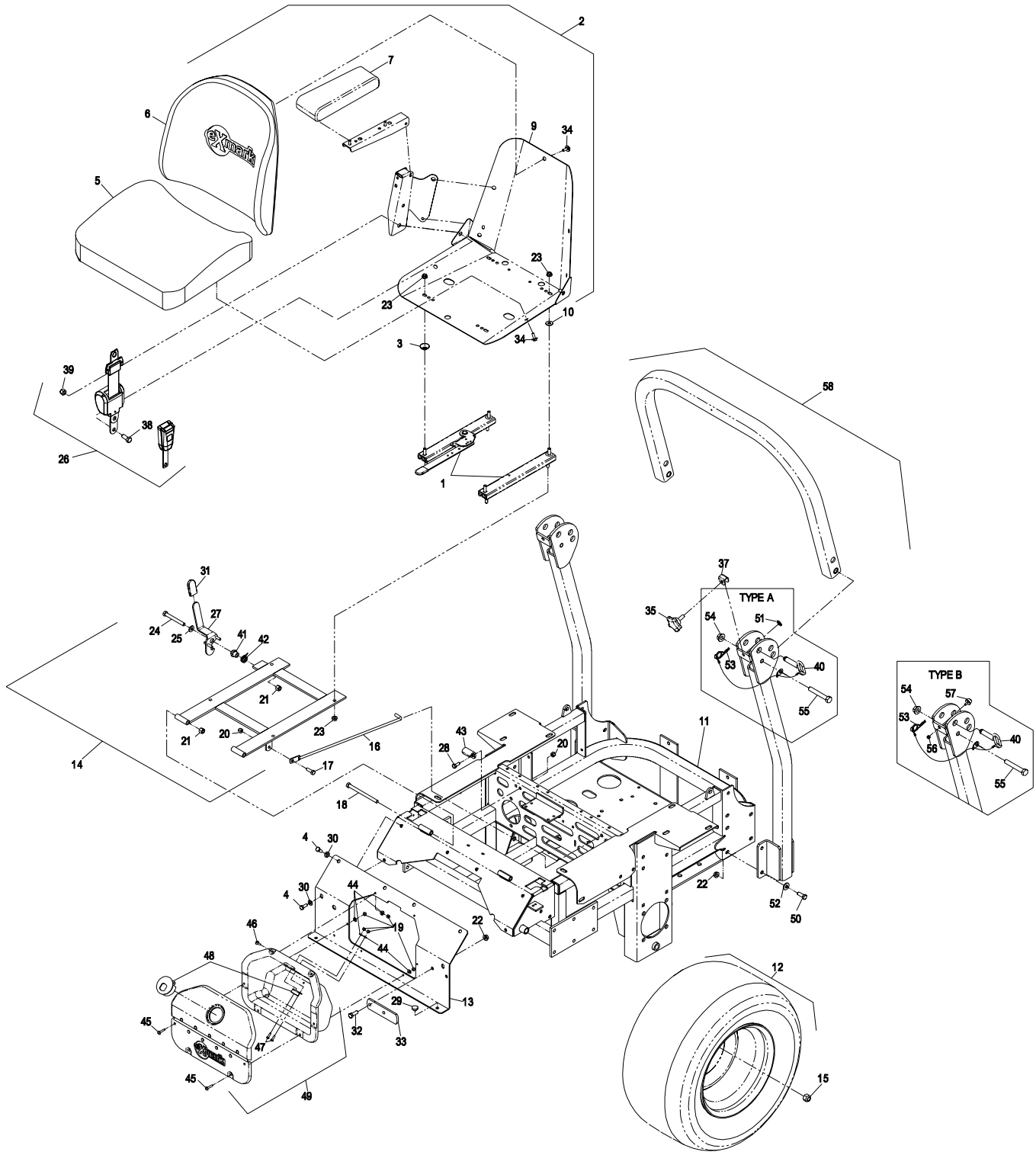



## 28 HP KOHLER EFI FUEL GROUP

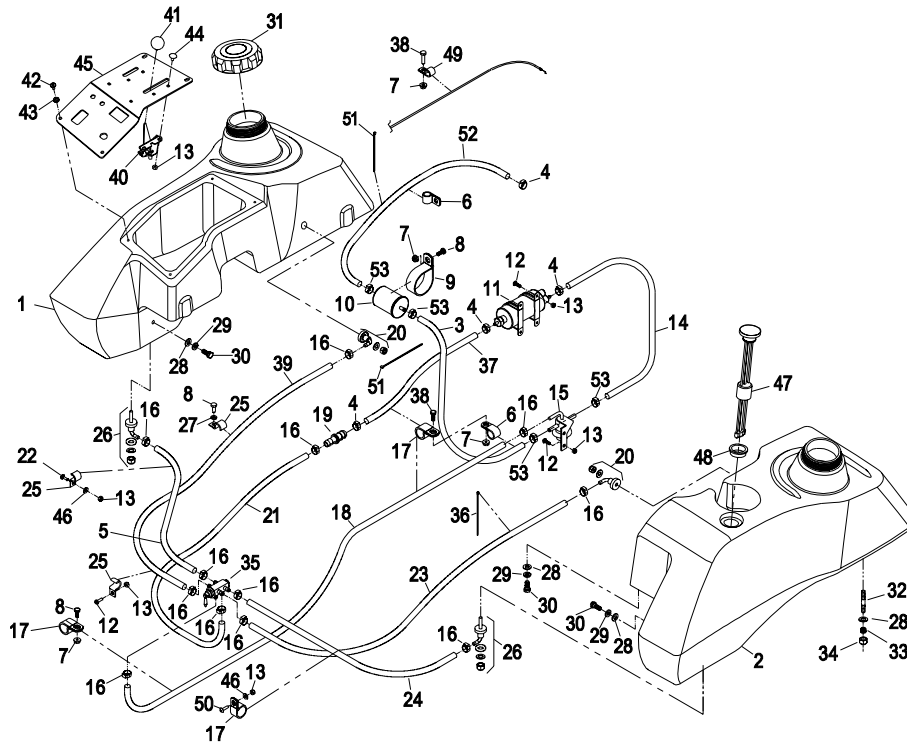

Item	Part No.	Description	Qty.
1*	109-0897	Asm, Tank EFI Fuel (RH).....	1
2*	103-4927	Asm, Tank EFI Fuel (LH).....	1
3	109-2070	Kit, Fuel Line W/Clamps.....	1
4▲	1-643277	Clamp, Fuel Line 5/16.....	4
5	109-0302	Hose, Fuel Line 24".....	1
6	1-603727	Clip, Loom.....	2
7	32128-33	Nut, Whizlock 1/4-20.....	4
8	321-3	Screw, Cap 1/4 -20 x 5/8.....	3
9	1-643241	Clip, Loom.....	1
10+	<b>Kohler</b>	Part No. 24 050 03 Fuel Filter (Large)....	1
11+	<b>Kohler</b>	Part No. 393 20 Fuel Pump.....	1
12	3290-500	Screw, Machine #10-24x5/8.....	7
13	3296-2	Nut, Nyloc #10-24.....	11
14	109-2067	Kit, Fuel Line W/Clamps.....	1
15+	<b>Kohler</b>	Part No. 24 403 17 Fuel Regulator.....	1
16▲	1-643293	Clamp, Fuel Line 1/4.....	12
17	1-643312	Clip, Loom.....	3
18	109-0285	Hose, Fuel Line 42".....	1
19	103-2595	Connector, 1/4x 5/16.....	1
20●	103-2615	Fitting, Fuel Blkhd W/O Screen.....	2
	103-2784	O-Ring.....	2
21	109-0293	Hose, Fuel Line 8 1/2".....	1
22	1-807533	Bolt, Carriage #10-24 x 5/8.....	1
23	109-0273	Hose, Fuel Line 38 1/4".....	1
24	109-0275	Hose, Fuel Line 32".....	1
25	103-1193	Clip, Loom Half.....	3
26●	103-2605	Fitting, Fuel Blkhd W/Screen.....	2
	103-2784	O-Ring.....	2

Item	Part No.	Description	Qty.
27	1-805004	Washer, Lock 1/4.....	1
28	3256-23	Washer, Flat SAE 5/16.....	10
29	1-805005	Washer, Lock 5/16 Hvy.....	4
30	322-3	Screw, 5/16-18 x 3/4.....	4
31	109-0346	Cap, Fuel Tank.....	2
32◆	1-633023	Stud, Fuel Tank.....	6
33	1-633349	Spring, Fuel Tank.....	6
34	3296-47	Nut, Thin Nyloc 5/16-18.....	6
35	1-643234	Valve, Fuel Dual Flow.....	1
36	1-303287	Plastic Tie (Small).....	1
37	109-0309	Hose, Fuel Line 28".....	1
38	321-6	Screw, 1/4-20 x 1.....	2
39	109-0286	Hose, Fuel Line 35".....	1
40	103-4091	Cable, Throttle.....	1
41	1-513592	Knob, Red (Throttle).....	1
42■	32122-30	Screw, Phillips Truss HD #10-24 x 1/2... 4	4
43	1-303435	Washer, Spring Disk 1/4.....	4
44	1-807513	Bolt, Carriage #10-24 x 1/2.....	4
45	109-2388	Asm, Control Panel W/Decals.....	1
46	3256-14	Washer, Washer, #10 Std.....	2
47	99-7262	Gage, Fuel.....	1
48	95-8972	Grommet.....	1
49	1-513762	Clip, Loom.....	1
50	1-803075	Screw, Truss HD #10-24 x 3/4.....	1
51	1-303335	Plastic Tie.....	2
52	109-2069	Kit, Fuel Line W/Clamps.....	1
53▲	103-6711	Clamp, Fuel Line 14.5 Oetiker (Black).... 4	4

- ✚ Refer to Engine Owner's Manual (Fuel Filter **Must** be 40 Micron or smaller).
- Use Pro-lock, Nut type (Part No. 1-840022), .5ml tube on fuel fitting.
- ◆ Use Pro-lock, Retaining Type (Part No. 1-840023), .5cc tube on stud threads going into the tank.
- \* Includes: tank, cap, fittings & studs. LH tank also includes fuel gauge.
- ▲ Clamps require special pliers Part No. 1-643394 (Oetiker Part No. 14100118 or Kohler Part No. 2445505) for installation.
- Snug fit only on slotted holes, **Do Not Overtighten**, tank must be able to expand.

## PARK BRAKE GROUP

Item	Part No.	Description	Qty.
1	1-513140	Bushing.....	2
2	1-633454	Spring, Brake Rod.....	2
3	1-633477	Rod, Brake.....	3
4	1-634500	Lever (1-632489-03)W/Grip .....	1
5	1-632217-03	Shaft, Brake.....	1
6	103-0352-03	Bracket, Brake (60").....	2
	103-0354-03	Bracket, Brake (66" & 72").....	2
7	1-523157	Washer, Spacer .....	2
8	1-809036	Nut, Slotted 1.00-20 .....	2
9	109-9761	Band, Brake.....	2
10	1-633380	Spacer (Short)(60") .....	4
*	1-633060	Spacer (Short) (66" & 72") .....	4
11	1-633382	Spacer (Long)(60").....	4
*	1-633062	Spacer (Long)(66" & 72") .....	4
12	1-633102	Bearing, Flange.....	2
13	1-633131	Yoke .....	4
14	1-633144	Pin, Trunion .....	2
15	103-0590	Hub & Drum W/Studs, Wheel.....	2
*	1-633926	Studs, Wheel .....	8

Item	Part No.	Description	Qty.
16	3257-42	Key, Woodruff 5/16 x 1 .....	2
17	1-633268	Grip, Brake Lever.....	1
18	323-4	Screw, 3/8-16 x 3/4.....	4
19	103-2399	Pin, Clevis Spring 3/8.....	3
20	325-17	Screw, 1/2-13 x 4 (60") .....	8
	325-20	Screw, 1/2-13 x 6 (66" & 72") .....	8
21	1481	Zerk, 1/4-28 45° .....	2
22	103-0131	Nut, Sq. Reg. 1/2-13 UNC-2B (60").....	8
◆	32128-49	Nut, Whizlock 1/2-13 (66" & 72").....	8
23	3219-3	Nut, 3/8-24.....	8
24	3290-357	Nut, Whizlock 3/8-16.....	4
25	3253-7	Washer, Lock 1/2.....	8
26	3256-4	Washer, 3/8 Std.....	4
27	3272-10	Pin, Cotter 1/8 x 3/4 .....	2
28	1-806800	Pin, Cotter 9/64 x 1 1/2 .....	2
29	322-9	Screw, 5/16-18 x 1 3/4 .....	6
30	103-0384	Spacer .....	6
31	103-0374	Retainer, Brake Band.....	2
32	1-808285	Pin, Clevis 3/8 x 1 1/8 .....	1

Exmark black touch up spray paint - gloss black.

\* Not Illustrated.

# PARK BRAKE GROUP

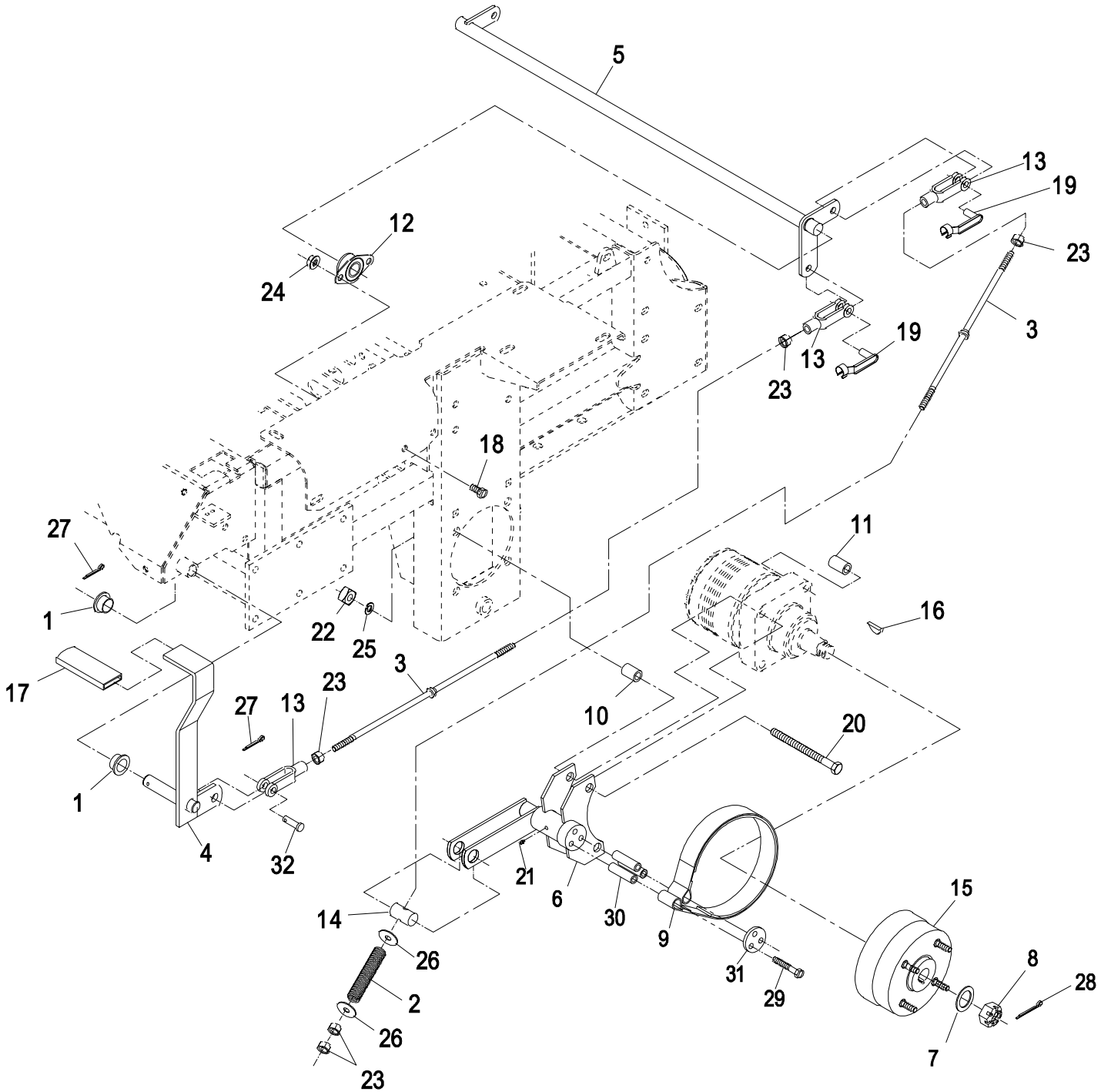



# ENGINE DECK GROUP

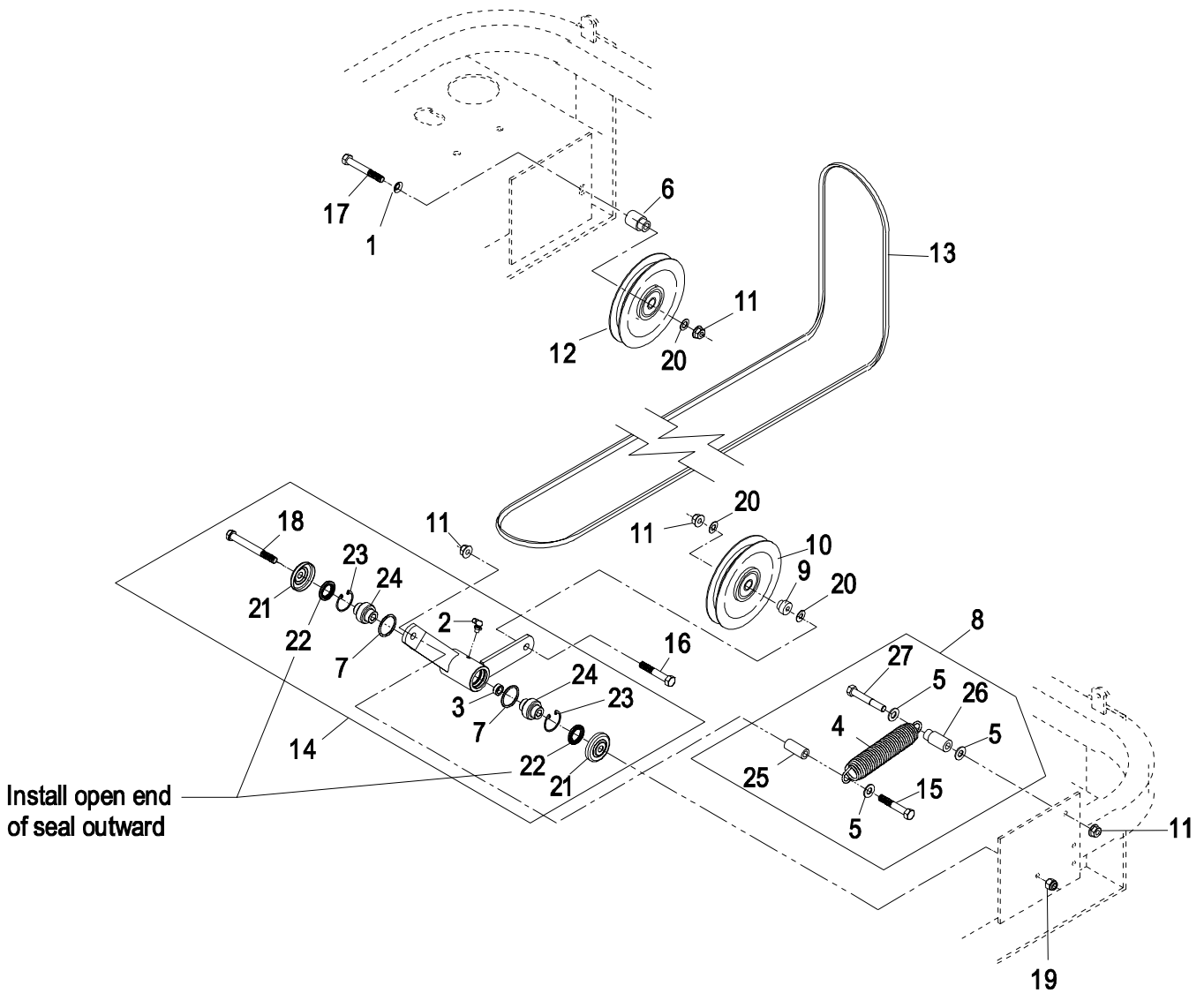

Item	Part No.	Description	Qty.
1	98-5975	Washer, Spring Disc 3/8.....	1
2	302-40	Zerk, 1/4-20 (90°).....	1
3	103-5677	Spacer .....	1
4	103-8599	Spring .....	1
5	3256-4	Washer, 3/8 Std .....	3
6	103-2627	Bushing, Idler .....	1
7	106-7159	O-ring.....	2
8■	103-9019	Kit, Mule Idler Spring.....	1
9	1-603496	Bushing, Idler .....	1
10	1-603805	Pulley, Idler .....	1
11	3290-357	Nut, Whizlock 3/8-16 .....	4
12	1-633166	Pulley, Idler .....	1
13	103-4014	Belt, Mule Drive.....	1
14✕	103-5695	Kit, Idler Arm (103-4593-03) W/Brgs .....	1

Item	Part No.	Description	Qty.
15	323-11	Screw, 3/8-16 x 2 1/4 .....	1
16	323-9	Screw, 3/8-16 x 1 3/4 .....	1
17	323-13	Screw, 3/8-16 x 2 3/4 .....	1
18	1-800805	Screw, 3/8-16 x 3 1/2 Gr8 .....	1
19	3296-39	Nut, Nyloc 3/8 .....	1
20	3256-24	Washer, 3/8 SAE .....	3
21	103-2916	Guard, Top .....	2
22	103-3506	Seal, Single Lip.....	2
23	32120-10	Ring, Retaining .....	2
24	103-3504	Bearing, Spherical .....	2
25	1-633082	Bushing .....	1
26	1-653366	Bushing, Shouldered.....	1
27	323-12	Screw, 3/8-16 x 2 1/2 .....	1

Exmark black touch up spray paint - gloss black.

✕ Kit also includes item #19.

■ Kit includes items #4, #5, #11 (2), #15, #25, #26, & #27.

## ENGINE DECK GROUP (cont.)

Item	Part No.	Description	Qty.
1	1-643315	Baffle, Engine Cooler (27HP, 28HP EFI & 30HP).....	1
2	1-805005	Washer, Lock 5/16 Hvy.....	4
3	1-523420	Bumper, Rubber.....	2
4	323-6	Screw, 3/8-16 x 1.....	1
5	33014-00	Nut, Hex M8 1.25.....	4
6	1-603610	Washer, Spring Disc.....	2
7	1-633615-03	Guard, Rear Engine.....	1
8	3256-4	Washer, 3/8 Std.....	1
9●	103-3245	Clutch Kit (23HP).....	1
●	103-3246	Clutch Kit (27HP & 30HP).....	1
●	103-5835	Clutch Kit (28HP EFI).....	1
	103-3012	Kit, Brake Pole Module.....	1
10	1-633453	Spacer (23HP).....	1
	1-633179	Spacer (27HP, 28HP EFI & 30HP).....	1
11	103-3340	Asm, Shield W/Decals.....	1
12	103-1308	Shield, Engine.....	1
13	323-9	Screw, 3/8-16 x 1 3/4.....	4
14	1-634796	Shield (LH) – Subassy.....	1
15	1-633301	Shield, Heat.....	2
16	321-4	Screw, 1/4-20x 3/4.....	1
17	1-643313-03	Shield, Muffler.....	1
18	1-644316	Shield (RH) – Subassy.....	1
19	1-523285	Clip, Shield.....	2
20	103-3535	Kit, Cable Heat Shield.....	1
21	52-4780	Rod, Belt.....	1

Item	Part No.	Description	Qty.
22	321-4	Screw, 1/4-20 x 3/4.....	10
23	106-7022	Tube, Oil Drain.....	1
24	323-6	Screw, 3/8-16x1 (23, 27 & 30HP).....	6
	323-6	Screw, 3/8-16 x 1 (28HP EFI).....	7
25▲	3212-10	Screw, 7/16-20 x 2 1/2.....	1
26	1-803035	Rivet, 3/16 x 1/4.....	11
27	3296-42	Nut, Nyloc 1/4-20.....	4
28	103-7454-03	Bracket, Guard Top.....	2
29	3256-2	Washer, 1/4 Std.....	4
30	103-1513	Arrester, Spark (1.25) (28HP EFI).....	1
31	1-653291	Gasket.....	2
32	3290-357	Nut, Whizlock 3/8-16 (23, 27 & 30HP)....	14
	3290-357	Nut, Whizlock 3/8-16 (28HP EFI).....	15
33	32128-33	Nut, Whizlock 1/4-20.....	9
34	1-633396	Clip, Loom .56.....	1
35	1-809108	Screw, Self Tapping 5/16-18x1.75.....	2
36	103-1514	Clamp, Muffler (1.38) (28HP EFI).....	1
37	1-323236	Spacer.....	2
38	3253-6	Washer, Lock 7/16.....	2
39	324-2	Screw, 7/16-14x.75 G5.....	2
40	98-5975	Washer, Spring Disc 3/8.....	5
41	3256-63	Washer, 3/16 Std.....	6
42+	92-6877	Valve, Oil Drain.....	1
43✱	103-7480	Kit, Muffler Kohler (23, 27 & 30HP).....	1
*	103-7483	Kit, Muffler Kohler (28HP EFI).....	1
44	9266934	Screw, 5/16-18x.5.....	2

Exmark black touch up spray paint - gloss black.

✚ Use a Teflon Pipe Sealant or equivalent on threads.

▲ Use Pro-Lock, Nut Type (P/N 1-840022, .5ml tube) on clutch bolt.

\* Includes items #20, #30, #36 & #50.

✱ Includes items #20, & #31.

### **Kohler Replacement Parts List**

(Refer to Engine Owner's Manual)

<u>Description</u>	<u>Kohler Part</u>
Engine Oil Filter.....	5205002
Engine Air Filter.....	2508301
Safety Filter.....	2508304

# ENGINE DECK GROUP (cont.)

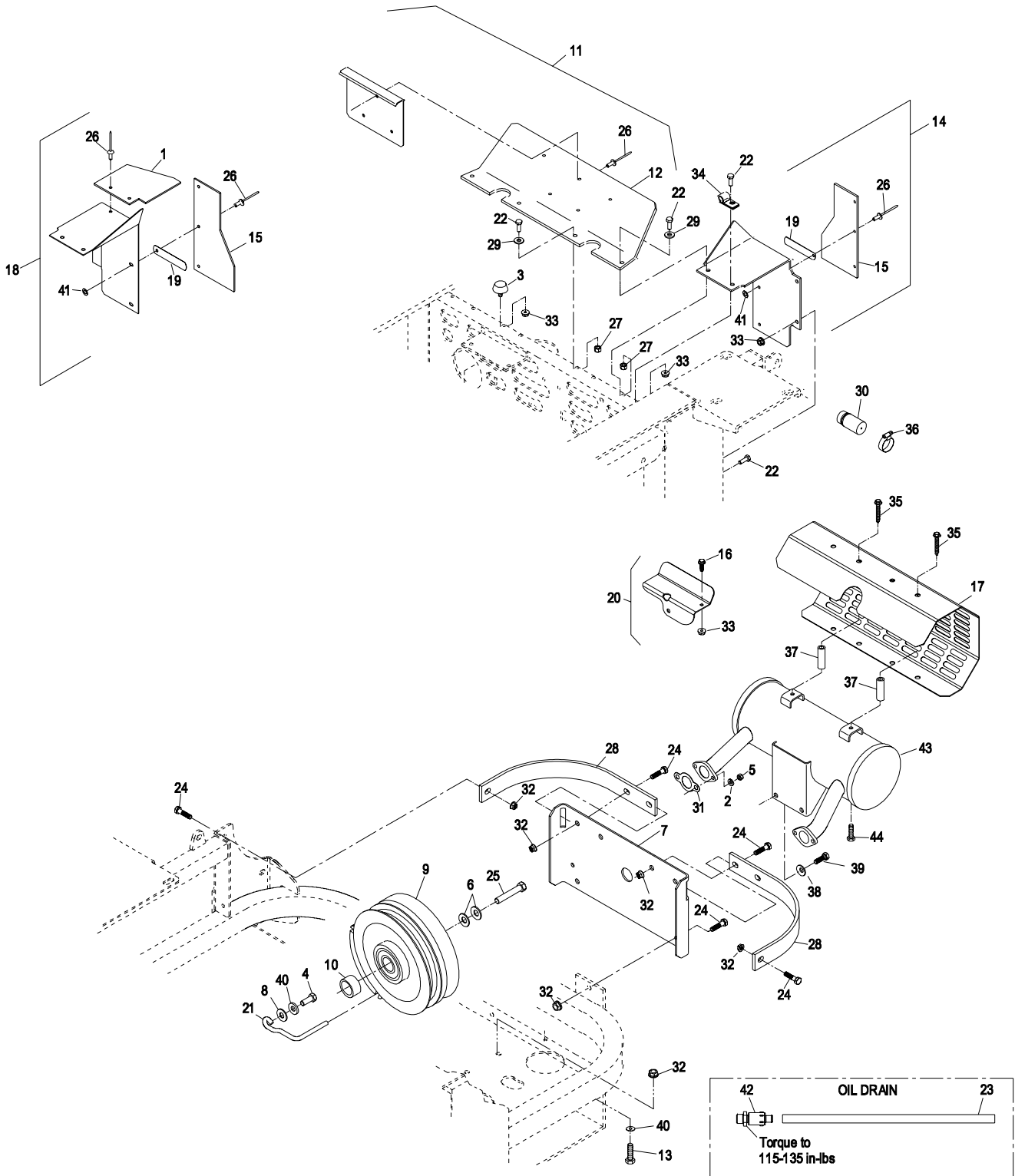

## HYDRAULIC GROUP

Item	Part No.	Description	Qty.
1	103-1947	Asm, Reservoir W/Decal .....	1
2	103-1948	Cap, Hydraulic Reservoir .....	1
3	103-1949	Gasket, Reservoir Cap.....	1
4	104-7836	Head, Filter .....	1
5	1-513211	Element, Hydraulic Oil Filter.....	1
▲	1-523541	Element, Hydraulic Filter (Winter).....	1
6	103-1988	Clamp, Hose (11/16).....	2
7	103-1716	Clamp, Hose (17/32).....	3
8	109-1936	Asm, Hose Hydraulic.....	1
	1-603921	Boss O-Ring .....	1
9	32120-10	Ring, Retaining .....	2
10	103-1808	Hose, Hydraulic.....	1
11	103-1806	Asm, Case Drain Hose.....	1
12	103-1807	Elbow,45°.....	1
	1-603921	Boss O-Ring .....	1
13	103-3506	Seal, Single Lip.....	2
14	103-1801	Adapter, Straight .....	1
	1-603921	Boss O-Ring .....	1
15	103-1912	Adapter, Straight .....	1
	1-603921	Boss O-Ring .....	1
16	103-1799	Elbow,90°.....	2
	1-603921	Boss O-Ring .....	1
17	321-3	Screw,1/4-20 x 5/8 .....	2
18	1-805004	Lockwasher, 1/4.....	2
19	103-1802	Elbow, 90°.....	2
	1-603921	Boss O-Ring .....	1
20	103-7262	Pump, Hydraulic.....	2
	103-7441	Kit, Input Bearing .....	1
	103-8448	Kit, Thrust Bearing .....	1
	103-7443	Kit, Cylinder Block.....	1
	105-6184	Kit, Overhaul Seal.....	1
	103-2741	Kit, Shock Value.....	1
21	1-603990	Connector, Straight .....	4
	1-603920	O-Ring (SAE #8) .....	1
	1-603992	O-Ring (37° Flare #8).....	1
22	103-6988	Motor, Wheel Drive .....	2
	103-6996	Kit, Output Shaft & Seals.....	1
	103-6994	Kit, Seal .....	1

Item	Part No.	Description	Qty.
23	103-3733	Hose, Upper LH (60").....	1
	103-3734	Hose, Upper (66" & 72").....	2
24	103-3735	Hose, Lower LH (60").....	1
	103-1863	Hose, Lower (66" & 72").....	2
25	103-3736	Hose, Upper RH (60").....	1
26	103-3737	Hose, Lower RH (60").....	1
27	103-6907	Sheave, Pump .....	2
28+	1-803022	Setscrew, Sq Hd 5/16-18 x 5/8.....	2
29+	30-1710	Setscrew, Sq Hd Cup 5/16-18 x 1 .....	2
30+	1-803050	Setscrew, Sq Hd Cup 5/16-18 x 3/4 .....	2
31	5-1077	Key, Machine 3/16 SQ x 1 .....	2
32	1-603991	Adapter, Straight (60") .....	4
	1-603919	Boss O-Ring .....	1
	1-603992	Flare O-Ring .....	1
	1-633786	Elbow,90° Long (66" & 72").....	4
	1-603919	Boss O-Ring .....	1
	1-603992	Flare O-Ring .....	1
33	1-633167	Pulley, Idler W/Bushing.....	1
34	103-5694	Kit, Idler Arm (103-4595-03) W/Bearings.....	1
35	323-9	Screw, HH 3/8-16 x 1 3/4.....	1
36	3256-3	Washer, Flat Std 5/16 .....	1
37	3290-357	Nut, Whizlock 3/8-16.....	8
38	103-5677	Spacer .....	1
39	32128-33	Nut, Whizlock 1/4-20.....	2
40	1-633567	Sheave, Engine .....	1
41	103-6906	Belt, Pump Drive.....	1
42	323-8	Screw,3/8-16 x 1 1/2 .....	1
43	1-800805	Screw,3/8-16 x 3 1/2 Gr8 .....	1
44	323-7	Screw,3/8-16 x 1 1/4 .....	4
45	106-7159	O-ring .....	2
46	13-2840	Key, 1/4 x 1/4 x 1 1/4.....	1
47	302-40	Zerk,90° 1/4-28.....	1
48	103-3504	Bearing, Spherical .....	2
49	103-3330	Spring, Extension.....	1
50	321-6	Screw, HH 1/4-20 x 1 .....	2
51	3256-22	Washer, SAE 1/4 .....	2
52	103-2916	Guard, Top .....	2

Exmark black touch up spray paint - gloss black.

✚ Use Pro-Lock, Nut Type (P/N 1-840022, 5 ml tube) on setscrews.

▲ Use only for operation below 32°F (0°C).

# HYDRAULIC GROUP

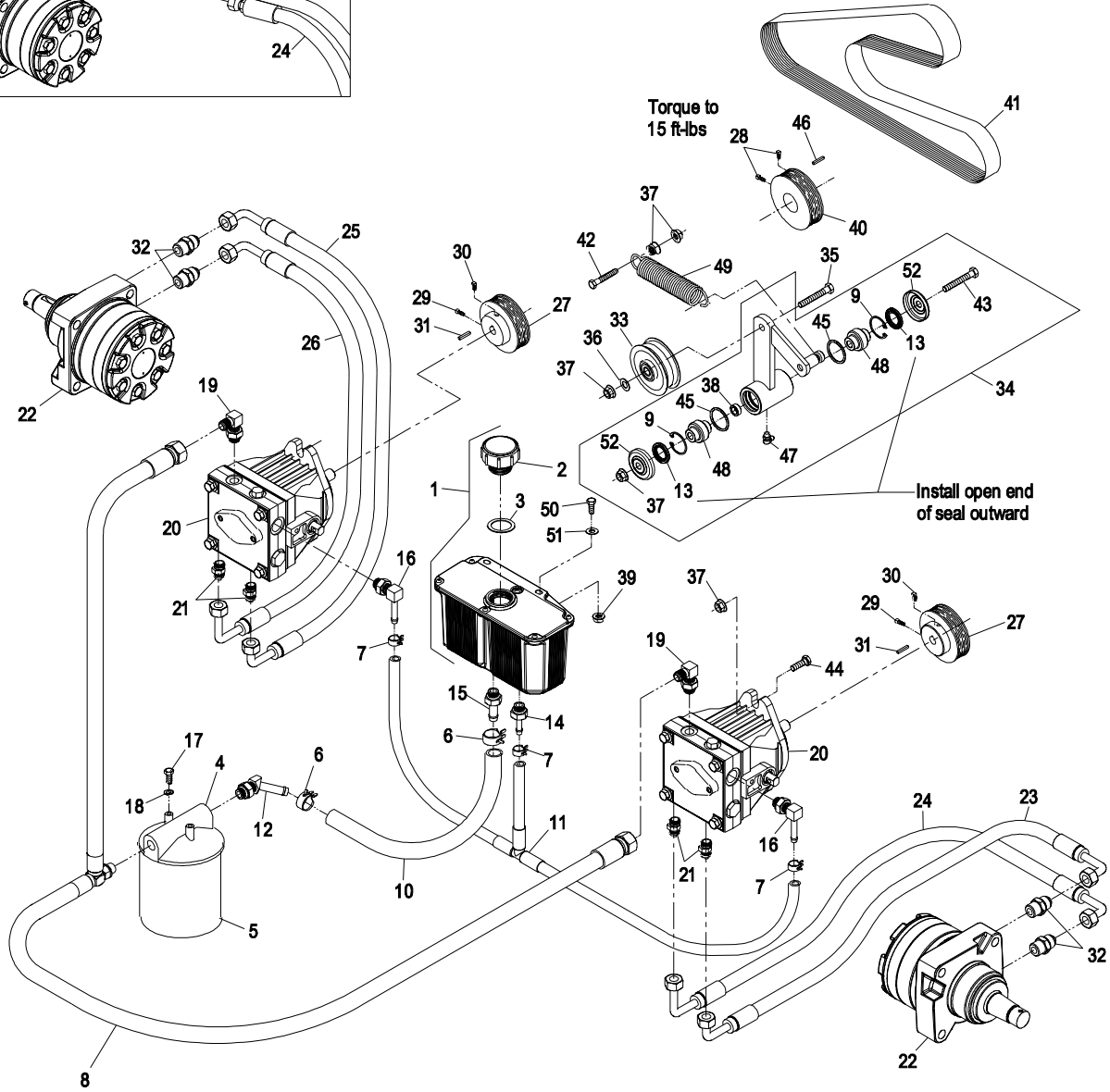
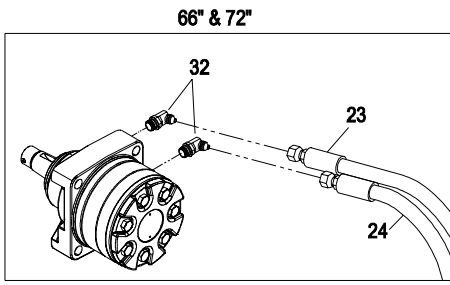

## DECAL GROUP

Item	Part No.	Description	Qty.
1	109-1214	Decal, Park Brake .....	1
2	109-1215	Decal, Cutting Height .....	1
3	107-2112	Decal, Warning Slope .....	1
4	103-6319	Decal, Check Service.....	1
5	109-2219	Decal, Belt Routing .....	1
6	109-0872	Decal, Baffle Adjustment.....	1
7	1-633706	Decal, Deck Height .....	1
8▲	103-1798	Decal, Throttle.....	1
9	109-1803	Decal, Triton 60.....	1
10	1-513742	Decal, No Step.....	2
11+	103-0261	Decal, Fuel Valve.....	1
12	1-513748	Decal, Guard.....	1
13▲	103-3113	Decal, Lazer Model .....	1
14	109-1804	Decal, Triton 66.....	1
15	1-643339	Decal, Pump Belt Rtg.....	1
16	1-303508	Decal, Discharge Warning.....	1
17	103-3270	Decal, 3750 RPM.....	1
18+	103-5177	Decal, EFI.....	1

Item	Part No.	Description	Qty.
19▲	103-4474	Decal, Ignition/PTO.....	1
20+	103-5456	Decal, Ignition/PTO EFI .....	1
21▲	103-4930	Decal, Choke .....	1
22	103-7491	Decal, Bolt Torque .....	1
23+	103-3679	Decal, Console Throttle .....	1
24	98-5954	Decal, Missing Cover.....	2
25	109-2113	Decal, Triton Badge .....	1
26+	103-2750	Decal, Relay/Fuse .....	1
27	107-2102	Decal, Rops Folding.....	1
28	109-1399	Decal, Anti-Scalp .....	1
29	103-5881	Decal, Rotating Devices.....	1
30	1-633462	Decal, Important .....	1
31	1-403005	Decal, Danger.....	2
32	109-1805	Decal, Triton 72 .....	1
33	1-523552	Decal, Hyd Tank/Hot Surface.....	1
34	103-2882	Decal, Exmark Logo.....	1
35	103-9255	Decal, Console Top .....	1
	103-5470	Decal Kit-Air-Cooled (Including EFI)	

▲ Decal for all units except Kohler EFI.

+ Decals for Kohler EFI units only.

# DECAL GROUP

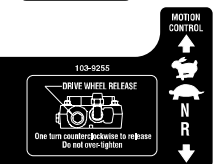
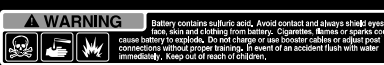
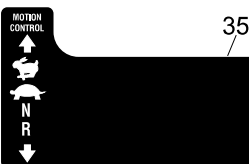
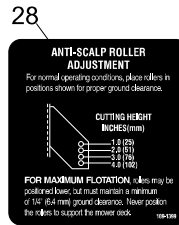
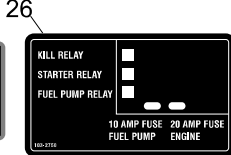
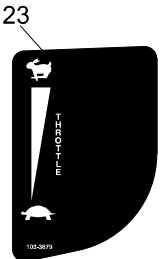
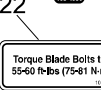
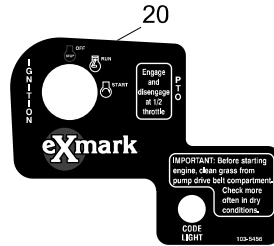
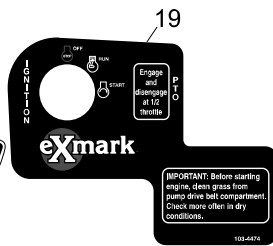
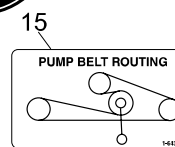
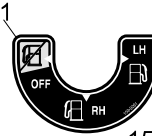
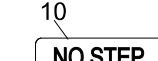
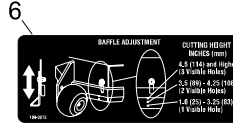
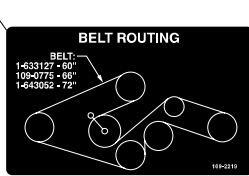
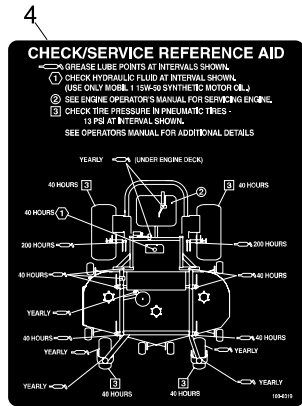
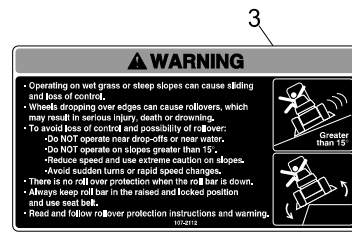

## 23, 27 & 30 HP KOHLER AIR-COOLED ELECTRICAL GROUP

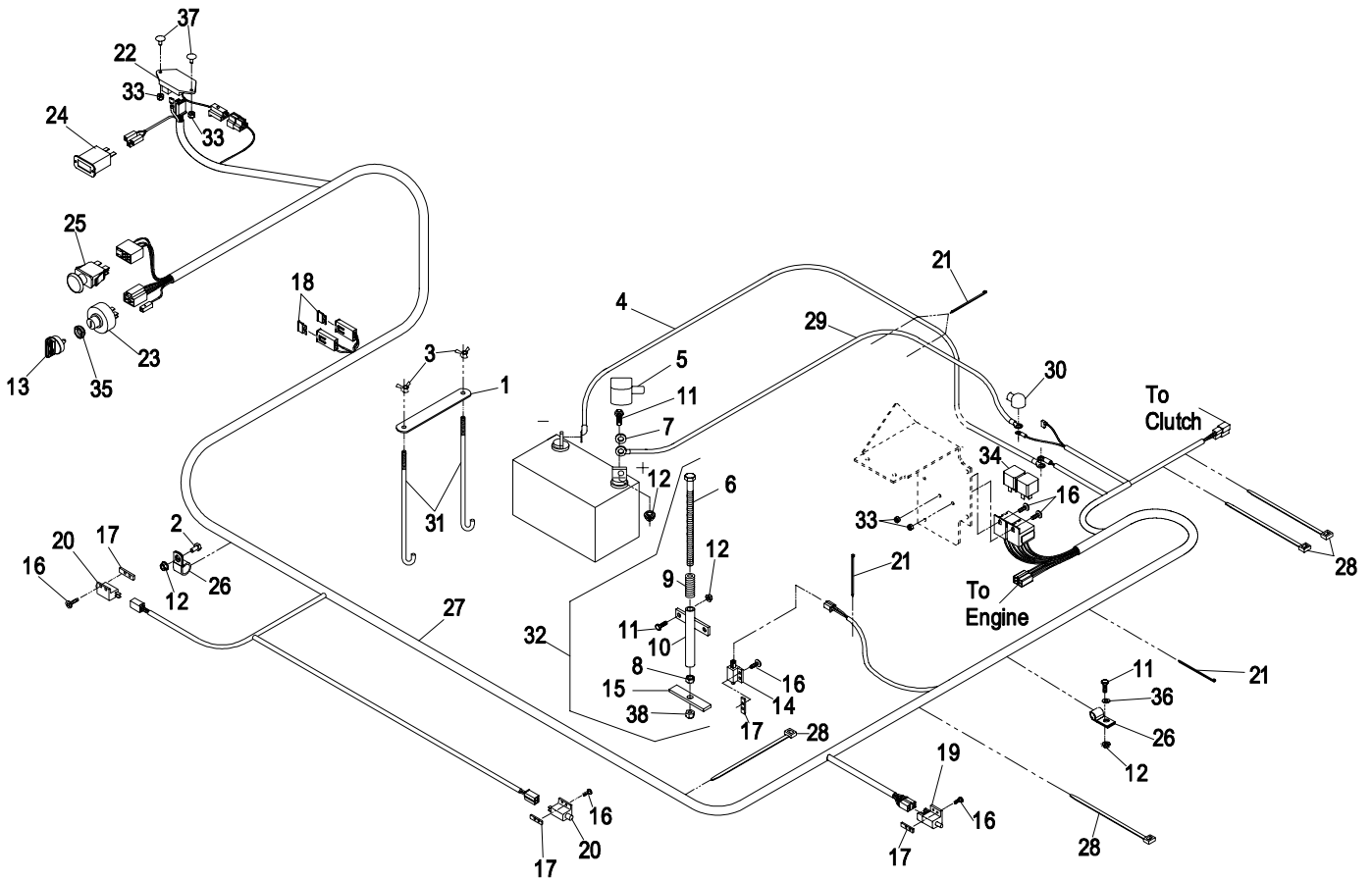

Item	Part No.	Description	Qty.
1	107-9277-03	Hold Down, Battery .....	1
2	321-2	Screw, 1/4-20 x 1/2 .....	1
3	1-543792	Wingnut, Nyloc.....	2
4	1-633307	Cable, Battery (-) 40".....	1
5	1-543391	Insulator, Battery.....	1
6	1-800282	Screw, 5/16-18 x 7 .....	1
7	3256-2	Washer, 1/4 Flat.....	2
8	3217-6	Nut, Hex 5/16-18 .....	1
9	1-523415	Spring, Seat Switch.....	1
10	1-522424-03	Wldmt, Spring Mount.....	1
11	321-4	Screw, 1/4-20 x 3/4 .....	5
12	32128-33	Nut, 1/4-20 Whizlock.....	6
13	103-2106	Key, Exmark Logo.....	1
	1-603511	Key, Ignition .....	1
14	1-513152	Switch, Seat N.C.....	1
15	1-513180	Actuator, Seat Switch.....	1
16	3290-500	Screw, #10-24 x 5/8 .....	10
17	1-633181	Plate, Tapped.....	4
18	1-816001	Fuse-20 Amp .....	2
19	1-633111	Switch, Brake N.O./N.C.....	1

Item	Part No.	Description	Qty.
20	1-513051	Switch, Drive Lever N.O.....	2
21	1-303287	Plastic Tie (Small).....	5
22	103-5218	Module, Seat Delay .....	1
23	103-0206	Switch, Ignition W/ Keys .....	1
24	1-513374	Meter, Engine Hours.....	1
25	103-5221	Switch, PTO.....	1
26	1-633396	Clip, Loom .69 .....	2
27▲	109-0125	Harness, Wiring .....	1
28	1-303335	Plastic Tie (Large).....	4
29	1-523281	Cable, Battery (+) 30" .....	1
30	1-543393	Insulator, Solenoid (+).....	1
31	1-633651	Bolt, Battery Hold Down .....	2
32	103-5652	Asm, Seat Switch Actuator.....	1
33	3296-2	Nut, #10-24 Hex Nyloc.....	4
34	1-643275	Relay, 12V .....	2
35	103-0498	Nut, Ignition .....	1
36	3256-22	Washer, 1/4 SAE .....	1
37	1-807513	Bolt, Carriage #10-24 x 1/2 .....	2
38	3296-29	Nut, 5/16-18 Nyloc.....	1

▲ Use dielectric grease on all wiring harness connectors.

## 28 HP KOHLER EFI ELECTRICAL GROUP

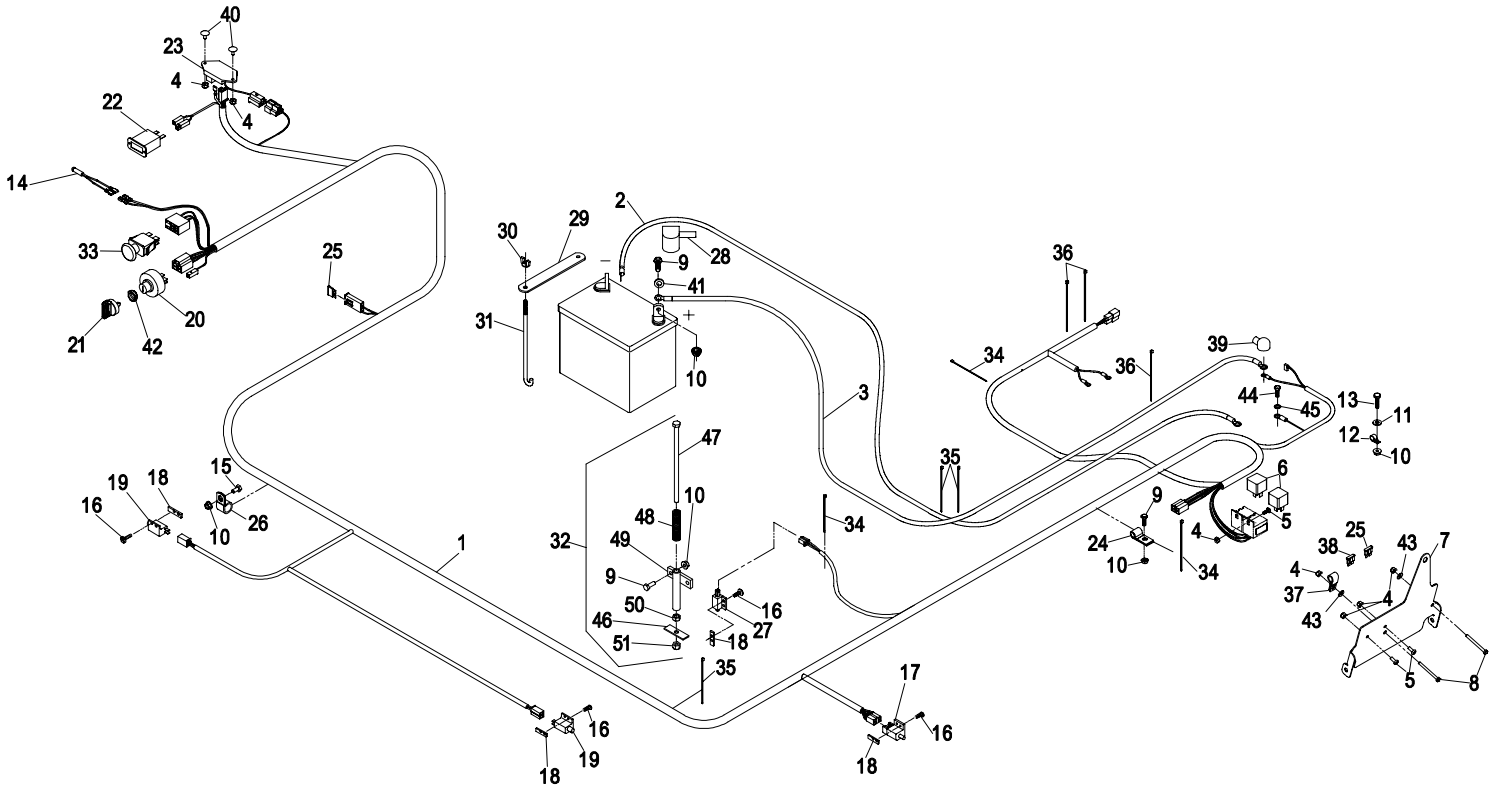

Item	Part No.	Description	Qty.
1▲	109-0124	Harness-Wiring .....	1
2	1-633307	Cable-Battery (-) .....	1
3	1-523279	Cable- Battery (+).....	1
4	3296-2	Nut, Nyloc #10-24 .....	8
5	1-803071	Screw, Machine #10-24 x 1/2.....	4
6	1-643275	Relay, 12V .....	2
7	103-7455-03	Panel, Fuse & ECU Mount .....	1
8	32105-20	Screw, Mach #10-24 x 2.....	2
9	321-4	Screw, 1/4-20 x 3/4 .....	5
10	32128-33	Nut, 1/4-20 Whizlock.....	7
11	3256-22	Washer, 1/4 SAE Flat.....	1
12	1-643312	Clip, Loom 1.0.....	1
13	321-6	Screw, 1/4-20 x 1 .....	1
14	1-643267	Indicator, Red Led.....	1
15	321-2	Screw, 1/4-20 x 1/2 .....	1
16	3290-500	Screw, #10-24 x 5/8 .....	8
17	1-633111	Switch, N.O./N.C. ....	1
18	1-633181	Plate- Tapped .....	4
19	1-513051	Switch, Drive Lever N.O.....	2
20	103-0206	Switch-Ignition W/Keys .....	1
21	103-2106	Key, Exmark Logo.....	1
	1-603511	Key, Ignition .....	1
22	1-513374	Meter- Engine Hours .....	1
23	103-5218	Module, Seat Delay.....	1
24	1-513762	Clip, Loom .50.....	2
25	1-816001	Fuse-20 Amp .....	2

Item	Part No.	Description	Qty.
26	1-633396	Clip, Loom .69 .....	1
27	1-513152	Switch, Seat N.C.....	1
28	1-543391	Insulator, Battery.....	1
29	107-9277-03	Holddown, Battery .....	1
30	1-543792	Wingnut, Nyloc.....	2
31	1-633651	Bolt, Battery Holddown .....	2
32	103-5652	Asm, Seat Switch Actuator.....	1
33	103-5221	Switch, PTO.....	1
34	1-303287	Plastic Tie (Small).....	3
35	1-303335	Plastic Tie (Medium) .....	3
36	1-643115	Plastic Tie (Large).....	3
37	1-323229	Clip, Loom 3/8 .....	1
38	1-816002	Fuse, 10 Amp .....	1
39	1-543393	Insulator, Solenoid + .....	1
40	1-807513	Bolt, Carriage #10-24 x 1/2 .....	2
41	3256-2	Washer, 1/4 Flat .....	2
42	103-0498	Nut, Ignition .....	1
43	3256-14	Washer, #10 .....	2
44	33114-016	Screw, M8-1.25 X 16mm .....	1
45	3256-23	Washer, 5/16 SAE .....	1
46	1-513180	Actuator, Seat Switch.....	1
47	1-800282	Screw, 5/16-18 X 7 .....	1
48	1-523415	Spring.....	1
49	1-522424-03	Wldmt, Seat Spring Mount .....	1
50	3217-6	Nut, Hex 5/16-18 .....	1
51	3296-29	Nut, 5/16-18 Nyloc.....	4

▲ Use dielectric grease on all wiring harness connectors.





# 23, 27 & 30 HP KOHLER AIR-COOLED ELECTRICAL LOGIC SCHEMATIC

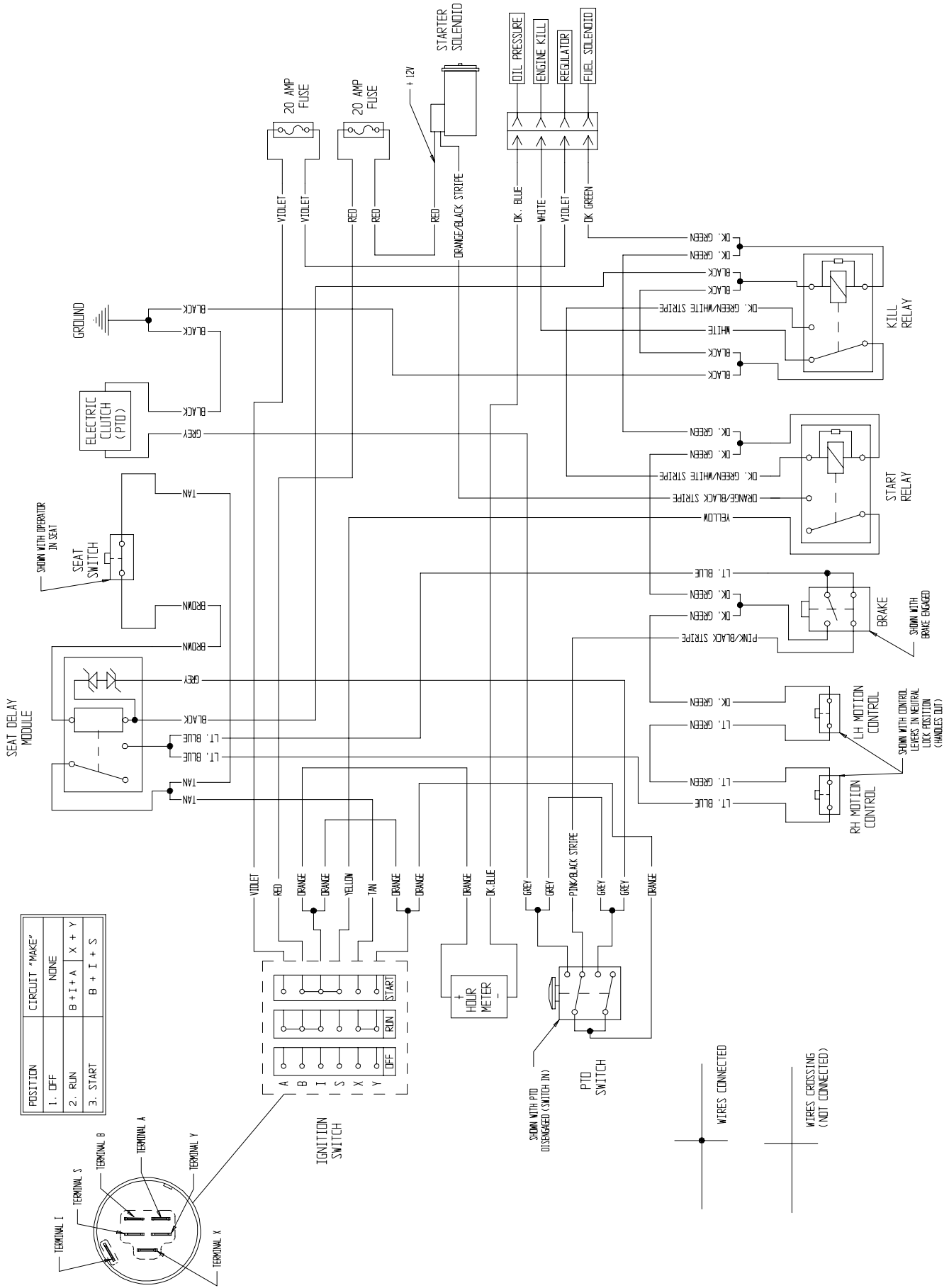

# 28 HP KOHLER EFI ELECTRICAL LOGIC SCHEMATIC

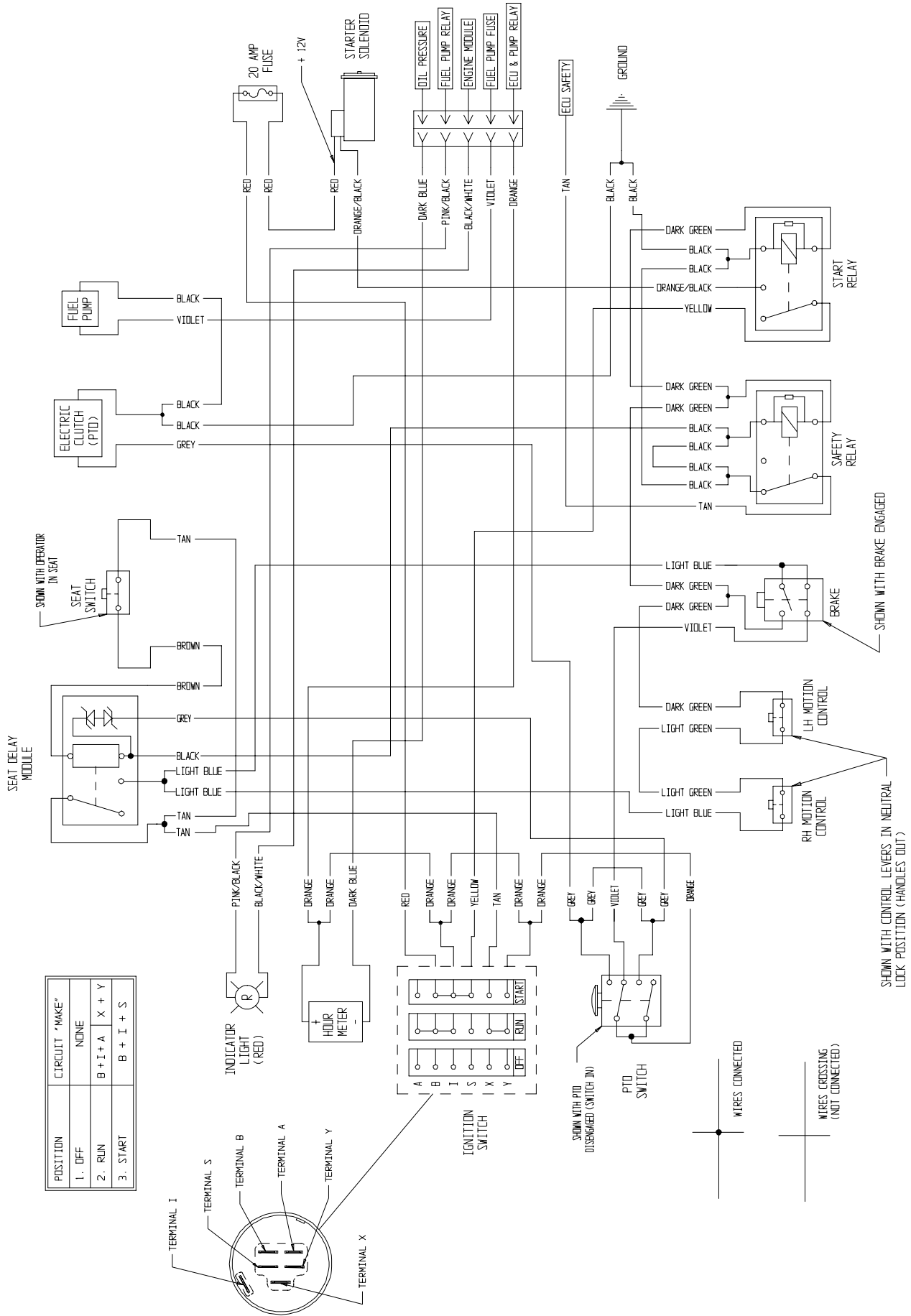



## NOTES

## **SEE EXMARK'S COMPLETE LINE OF ACCESSORIES**

### **RIDING ACCESSORIES**

CUSTOM RIDE SEAT SUSPENSION SYSTEM  
DECK LIFT ASSIST KIT  
HITCH KIT  
LIGHT KIT  
MICRO-MULCH SYSTEM  
ROLL OVER PROTECTION SYSTEM (ROPS)  
SNOW BLADE  
SUN SHADE  
TRASH CONTAINER  
TURF STRIPER  
ULTRA VAC COLLECTION SYSTEM  
ULTRA VAC QUICK DISPOSAL SYSTEM

### **WALK BEHIND ACCESSORIES**

GRASS CATCHER  
MICRO-MULCH SYSTEM  
STEERABLE SULKY  
SULKY HITCH KIT  
TURF STRIPER  
STANDON

Check us out on the Web:  
**[www.exmark.com](http://www.exmark.com)**

© 1997-2005 EXMARK MFG. CO. INC.  
INDUSTRIAL PARK BOX 808  
BEATRICE, NE 68310

PART NO. 109-2696 Rev. A  
(402) 223-6300  
FAX (402) 223-5489

ALL RIGHTS RESERVED

PRINTED IN U.S.A.

