



**Count on it.**

**Parts Catalog**

**Power Max 826 OE Snowthrower**

Model No. 38629—Serial No. 312000001 and Up

# Ordering Replacement Parts

To order replacement parts, please supply the part number, the quantity, and the description of each part desired.

## Understanding Reference Numbers

Each identified part in an illustration has a reference number. The reference number for a part also appears in the parts list, along with other information about the part.

This catalog uses two special reference number formats, one to indicate parts in a service assembly and another to indicate the quantity of a given part in an illustration.

## Service Assembly Reference Numbers

Parts in service assemblies have reference numbers in the form a:b. The a represents the reference number of the entire service assembly and the b represents a sequential number unique to each part within the service assembly.

For example, a wheel assembly might be identified by reference number 6, the tire by 6:1, the valve by 6:2, and the wheel by 6:3. When you order the assembly identified by reference number 6, you receive all parts identified by reference numbers 6:1, 6:2, and 6:3. However, you may also order any part individually. Reference numbers of this type appear in illustration and in parts lists.

## Reference Numbers Indicating Quantity

In an illustration, if a reference number indicates more than one part, the reference number has the form nX y. The n represents the quantity of the part, the X is the multiplication symbol, and the y represents the reference number.

For example, in an illustration, the reference number 2X 37 means that two of the parts identified by reference number 37 are indicated.

# List of Abbreviations

**AR:** as required

**ASM:** assembly

**BBC:** blade brake control

**BHTF:** button head thread forming

**CARR:** carriage

**CCW:** counter clockwise

**CW:** clockwise

**DEG:** degrees

**DPA:** Dual Point Adjustment

**ECM:** electronic control module

**EXT:** external

**FH:** flat head

**GA:** gauge

**HD:** heavy-duty

**HF:** hex flange

**HH:** hex head

**HHF:** hex head flange

**HHFTF:** hex head flange thread forming

**HJ:** hex jam

**HLH:** hex lag head

**HOC:** height-of-cut

**HSBH:** hex socket button head

**HSFH:** hex socket flat head

**HSH:** hex socket head

**HWH:** hex washer head

**HWTF:** hex washer head thread forming

**HYD:** hydraulic

**LH:** left hand

**LP:** Liquid Propane

**NI:** nylon insert

**NPTF:** national pipe thread fine

**PFH:** phillips flat head

**PPH:** phillips pan head

**PPHTF:** phillips pan head thread forming

**PRH:** phillips round head

**PTH:** phillips truss head

**PTO:** power-take-off

**RH:** right hand

**ROPS:** roll-over protection system

**RRB:** rear roller brush

**SFH:** slotted fillister head

**SHH:** slotted hex head

**SHWH:** slotted hex washer head

**SPH:** slotted pan head

**SQH:** square head

**SRH:** slotted round head

**STD:** standard

**TAP:** self tapping

**TTH:** torx truss head

# Contents

Auger and Housing Assembly .....	4
26 Inch Auger Gearcase Assembly No. 108-7328 .....	6
Chute Assembly .....	7
Chain Drive Assembly .....	8
Frame Assembly .....	9
Handle and Control Assembly .....	11
Handle Assembly .....	12
Lever Chute Control Assembly .....	13
Engine Assembly .....	14
Attachments and Accessories .....	15

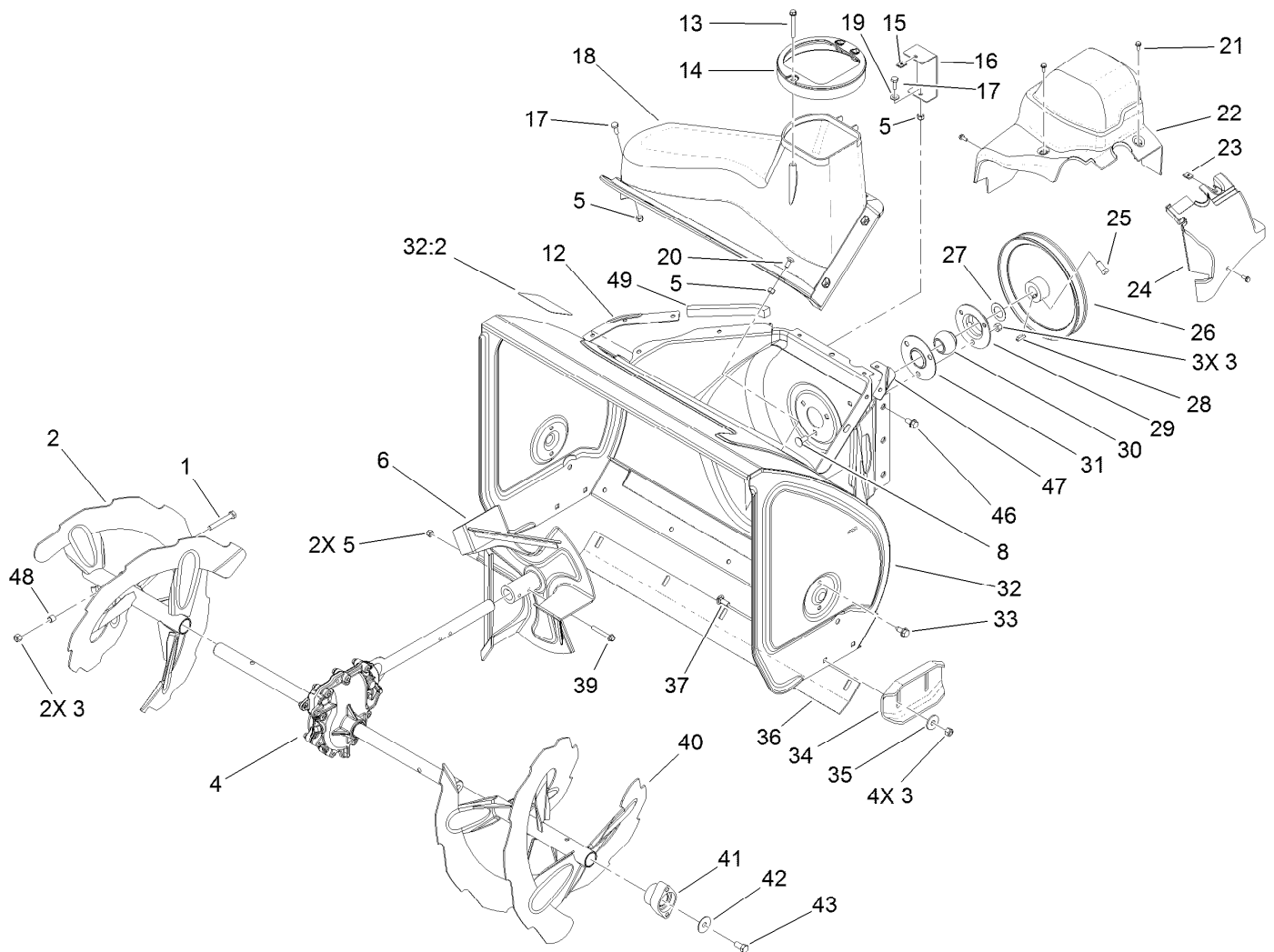

## Auger and Housing Assembly

Ref.	Part Number	Qty.	Description	Ref.	Part Number	Qty.	Description
1	322-11	2	Screw-HH	25	3242-4	2	Screw-Set, SQH
2	106-7289-03	1	RH Auger ASM	26	62-1300	1	Pulley-Impeller
3	3296-29	14	Nut-Lock, NI	27	252-80	1	Washer-Thrust
4	108-7328	1	26 Inch Auger Gearcase ASM	28	3257-23	1	Key-Woodruff
5	3296-42	13	Nut-Lock, NI	29	26-6110	1	Flange-Cup, Bearing
6	106-4576-03	1	Impeller ASM	30	63-3450	1	Bearing-Ball
8	3230-23	8	Screw-CARR	31	26-6120	1	Flange-Cup, Bearing
12	107-1017-03	1	Seal-Flange, Cover	32	107-3822	1	Housing-Auger, 26 Inch
13	107-3003	1	Screw-Plastite	32:2	107-3040	1	Decal-Danger, Auger
14	107-3006	1	Guide-Chute	33	32144-70	4	Screw-HWHTF
15	107-1013	1	Nut-Speed, U-Type	34	106-4588-01	2	Skid
16	107-1014-03	1	Bracket-Cover, Clip Nut	35	52-2861	4	Washer
17	321-4	7	Screw-HH	36	105-9976-01	1	Scraper-Fixed
18	108-0017	1	Cover	37	3230-16	4	Screw-CARR
19	3256-22	1	Washer-Flat	39	321-44	2	Screw-HHF
20	3229-1	4	Screw-CARR	40	106-7299-03	1	LH Auger ASM
21	32144-112	4	Screw-HWH	41	106-4570	2	Auger-Bearing
22	119-1563	1	Cover-Belt	42	3-0750	2	Washer
23	701493	1	Nut-Speed	43	323-4	2	Screw-HH
24	107-1016	1	Cover-Extension, Belt	46	32144-14	6	Screw-HWHTF
				47	108-0039-03	1	Seal

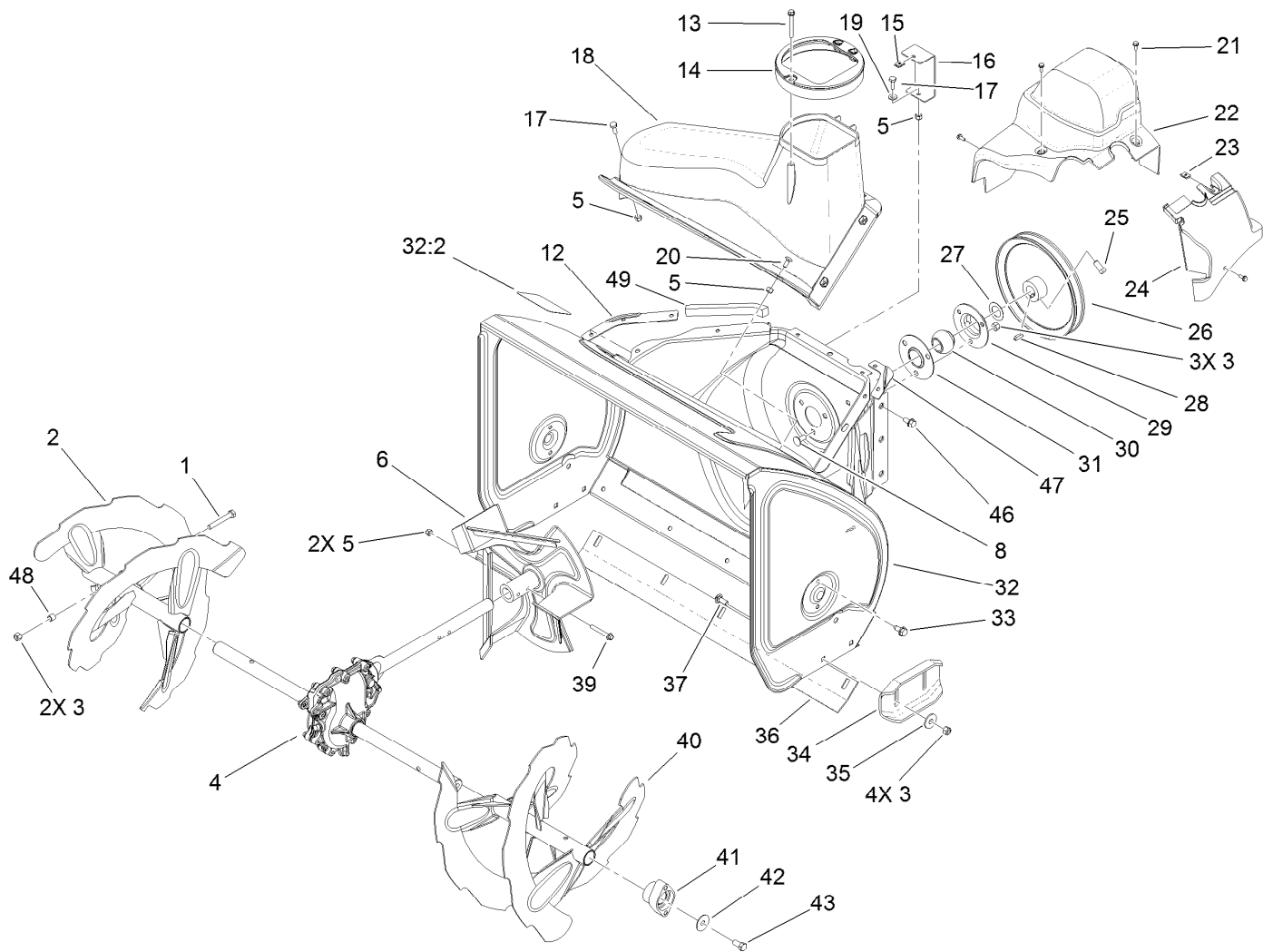

## Auger and Housing Assembly (continued)

<i>Ref.</i>	<i>Part Number</i>	<i>Qty.</i>	<i>Description</i>
48	1-633545	2	Spacer
49	120-0124	1	Seal-Housing

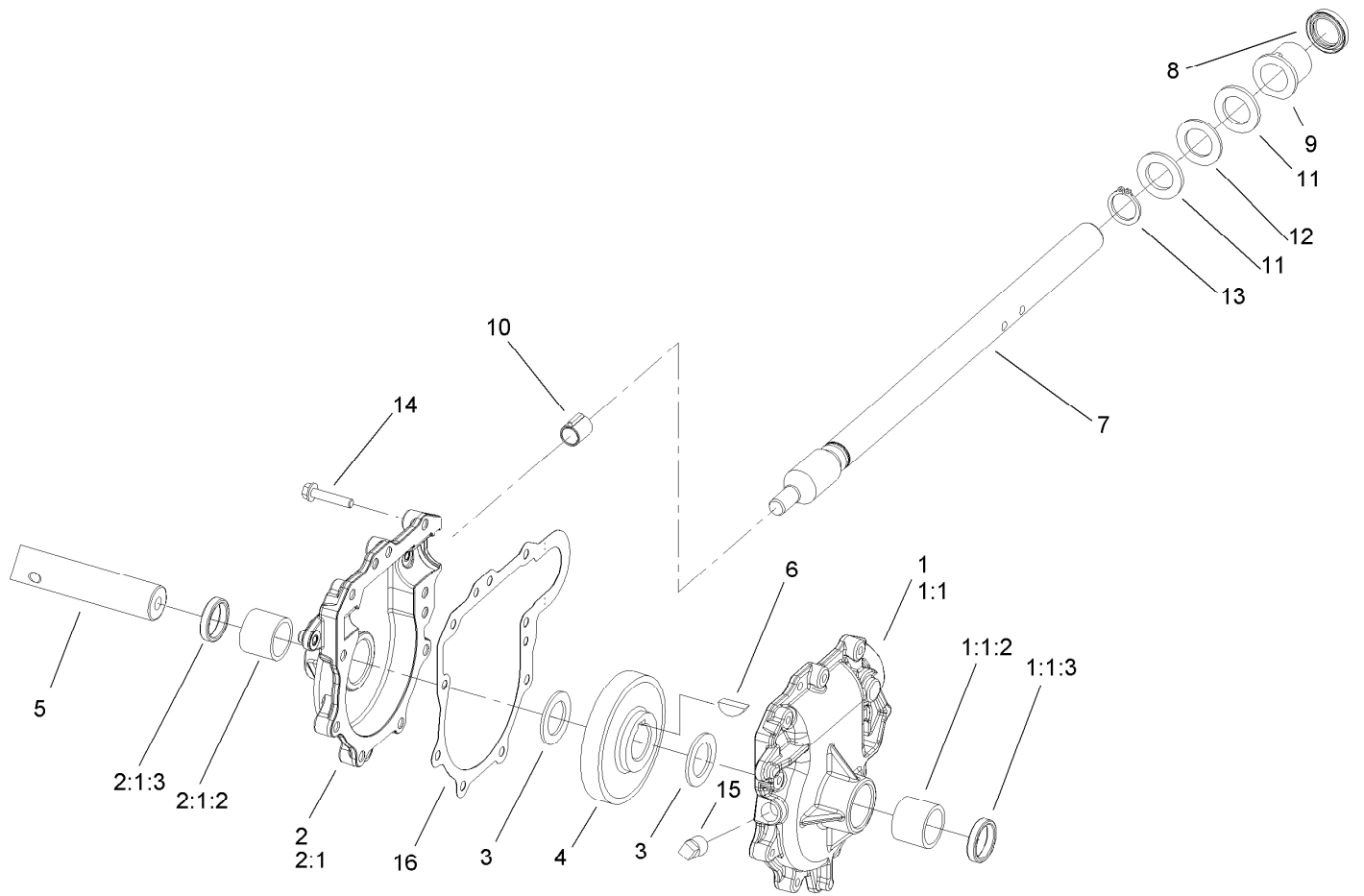

## 26 Inch Auger Gearcase Assembly No. 108-7328

Ref.	Part Number	Qty.	Description
1	108-7325	1	LH Auger Gearcase ASM
1:1		1	Gearcase-Auger, LH ●
1:1:2	112-6635	1	Bushing-Sleeve
1:1:3	7-0045	1	Seal-Oil
2	108-7327	1	RH Auger Gearcase ASM
2:1		1	Gearcase-Auger, RH ●
2:1:2	112-6635	1	Bushing-Sleeve
2:1:3	7-0045	1	Seal-Oil
3	252-71	2	Washer-Thrust
4	62-0120	1	Gear-Helical
5	106-4579	1	Shaft-Auger
6	3257-10	1	Key-Woodruff
7	66-7811	1	Shaft-Impeller
8	253-149	1	Seal-Oil
9	37-6560	1	Bushing-Input
10	62-1150	1	Bushing-Worm
11	252-78	2	Washer-Thrust
12	252-76	1	Bearing-Thrust
13	32151-33	1	Ring-Retaining, EXT
14	108-4862	9	Screw-HWHTF
15	281-1	1	Plug-Pipe, SQH
16	108-7330	1	Gasket-Gearcase, Auger

● Not serviced separately

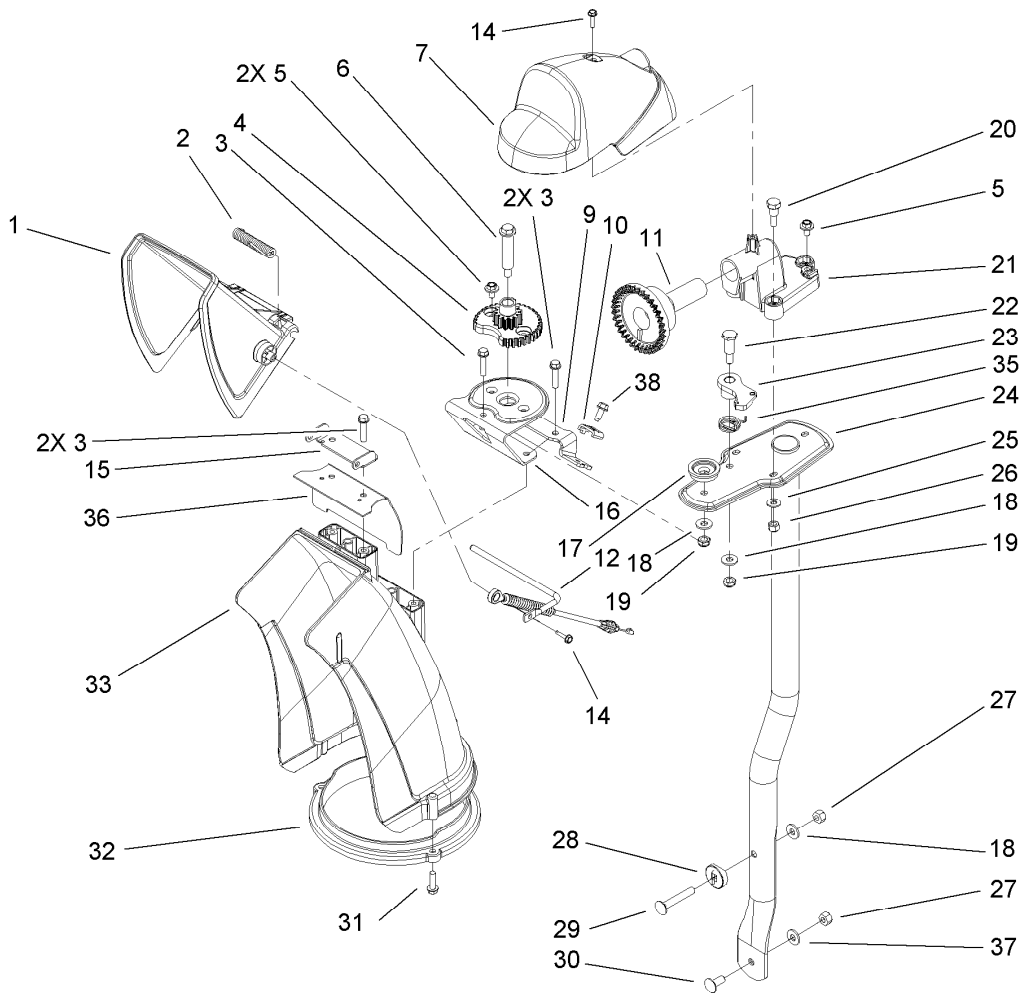

## Chute Assembly

<i>Ref.</i>	<i>Part Number</i>	<i>Qty.</i>	<i>Description</i>
1	112-6629	1	Deflector-Chute, Ce
2	106-4594	1	Spring-Torsion
3	46-8092	5	Screw-Plastite
4	106-4472	1	Gear-Chute
5	46-6810	3	Screw And Washer ASM
6	100-9880	1	Bolt-Shoulder
7	106-4585	1	Cover-Gear, Chute
9	106-7296	1	Bracket-Cable, Clamp
10	106-7297	1	Clamp-Cable
11	106-4471	1	Gear-Face
12	107-1021	1	Rod-Deflector
14	98-1375	2	Screw-HWH
15	106-7266	1	Bracket-Deflector
16	106-4582-03	1	Bracket-Support, Chute
17	106-4422	1	Spacer-Chute
18	3256-2	3	Washer-Flat
19	3296-47	2	Nut-Lock, NI
20	106-7276	3	Screw-Shoulder

<i>Ref.</i>	<i>Part Number</i>	<i>Qty.</i>	<i>Description</i>
21	106-7257	1	Mount-Gear, Face
22	63-2650	1	Screw-Shoulder
23	106-4476	1	Latch-Chute
24	106-7253-03	1	Tube-Support
25	3256-22	3	Washer-Flat
26	3296-42	3	Nut-Lock, NI
27	3296-29	2	Nut-Lock, NI
28	106-7260	1	Washer-Curved
29	3230-5	1	Screw-CARR
30	3230-23	1	Screw-CARR
31	46-8091	3	Screw-HWH
32	105-9991	1	Ring-Chute
33	106-4440	1	Chute-Discharge
35	108-7315	1	Spring-Torsion
36	108-5052	1	Seal-Chute
37	3290-456	1	Washer-Belleville
38	32144-10	1	Screw-HWH

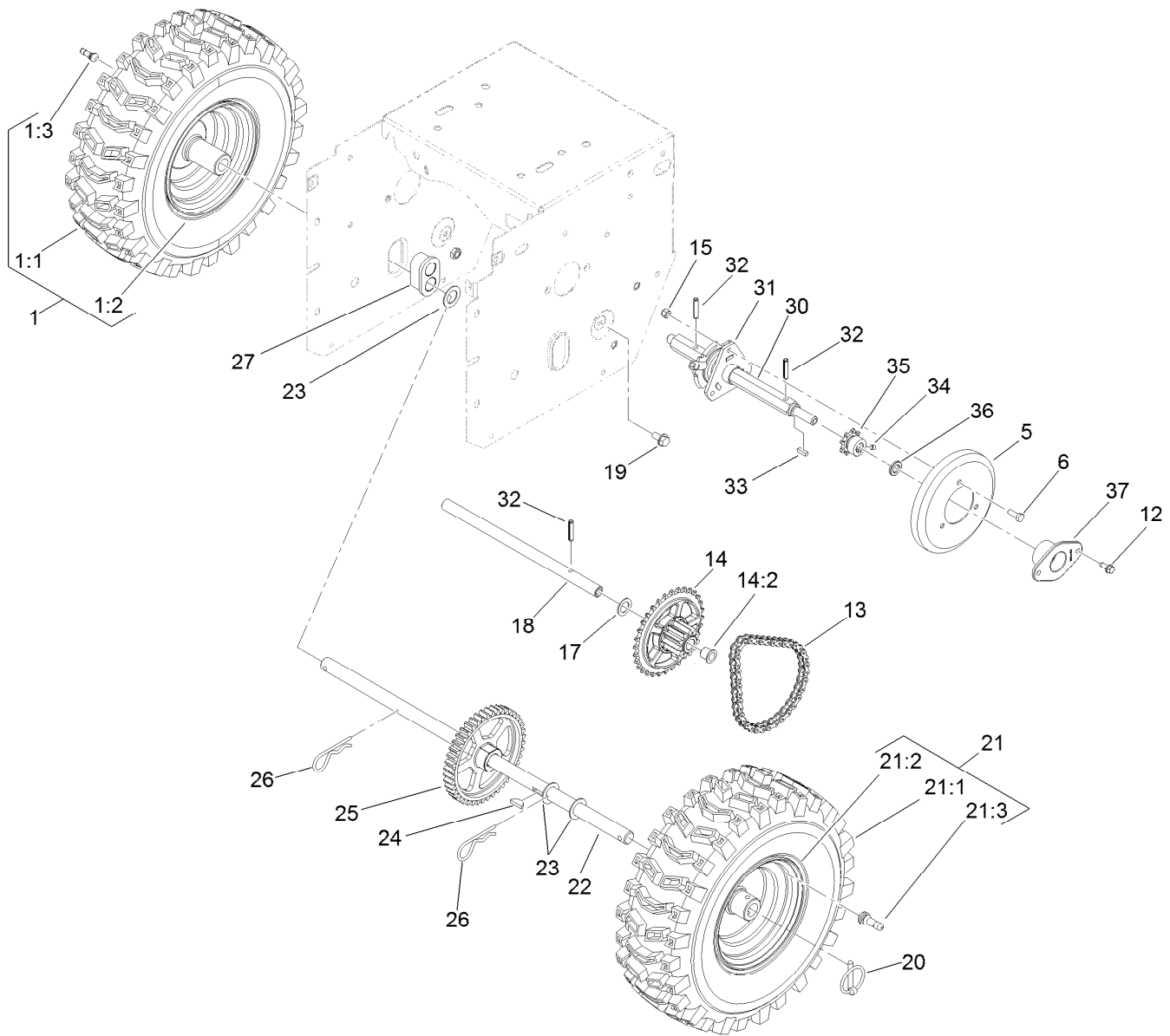

## Chain Drive Assembly

Ref.	Part Number	Qty.	Description	Ref.	Part Number	Qty.	Description
1		1	RH Wheel And Tire ASM ●	21:1	107-3042	1	Tire
1:1	107-3042	1	Tire	21:2	107-3043	1	Rim-Tire
1:2	107-3043	1	Rim-Tire	21:3	232-27	1	Stem-Valve
1:3	232-27	1	Stem-Valve	22	106-4449	1	Shaft-Axle
5	119-1567	1	Wheel-Friction	23	3-8664	3	Washer-Thrust
6	321-4	3	Screw-HH	24	3257-7	1	Key-Woodruff
12	32144-10	4	Screw-HWH	25	106-4572	1	Gear-Axle, 44 Tooth
13	108-0016	1	Chain-Roller	26	3290-343	2	Pin-Hair
13	2710-6	1	Link-Connecting	27	106-4558	2	Bearing-Axle
14	108-0013	1	Sprocket ASM	30	108-5054	1	Shaft-Hex
14:2	108-2974	2	Bushing-Flange	31	106-4434	1	Trunion-Hex
15	3296-42	3	Nut-Lock, NI	32	32121-9	3	Pin-Roll, Slotted
17	107-3041	1	Washer-Flat	33	94-8850	1	Key-Square
18	106-4592	1	Shaft-Intermediate	34	3245-32	2	Screw-HSH
19	32144-14	2	Screw-HWHTF	35	106-7317	1	Sprocket-8 Tooth
20	107-3039	2	Klik Pin ASM	36	108-5059	1	Spacer-Bushing
21		1	LH Wheel And Tire ASM ●	37	108-7319	2	Retainer-Bearing

● Not serviced separately

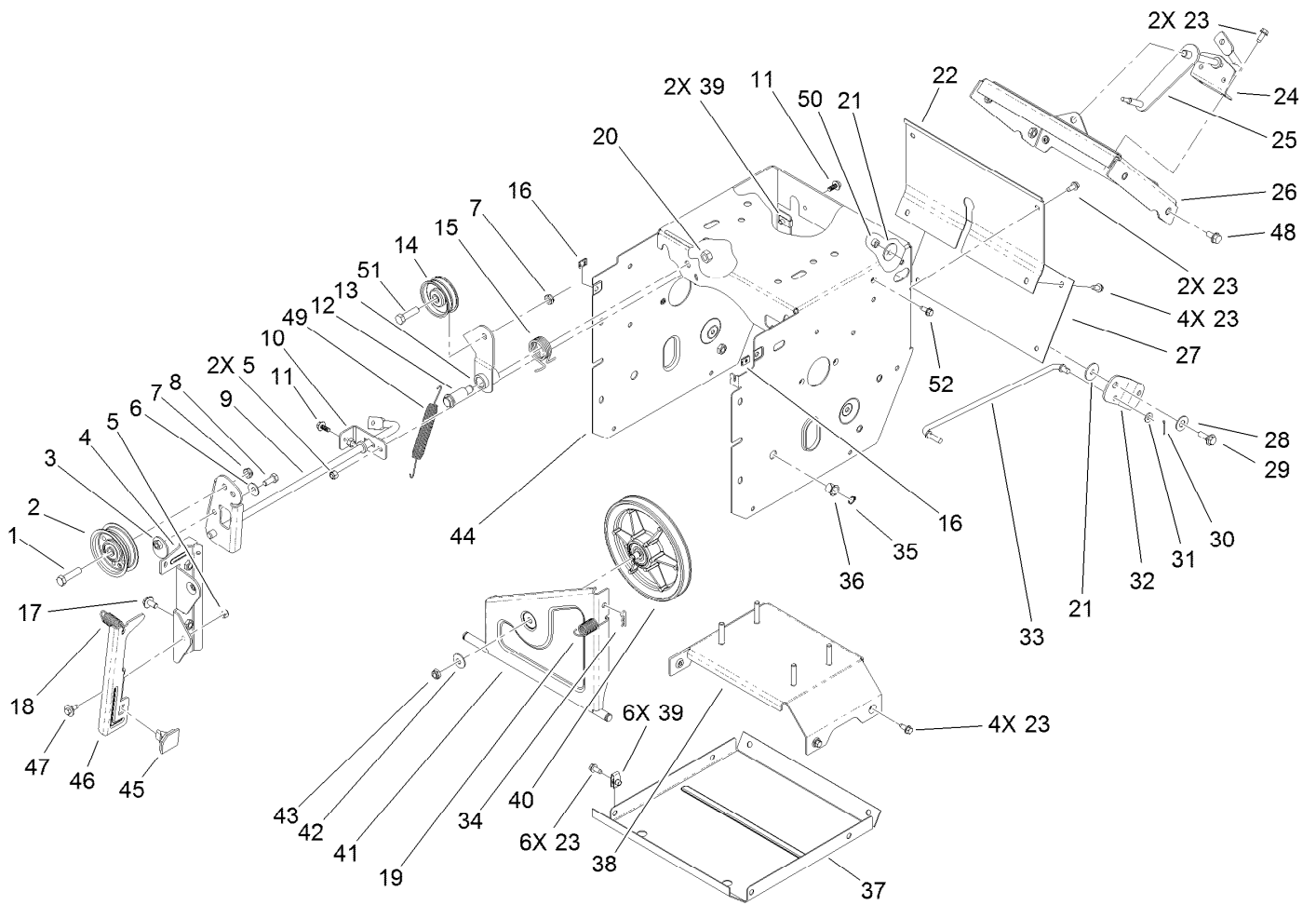

## Frame Assembly

Ref.	Part Number	Qty.	Description	Ref.	Part Number	Qty.	Description
1	323-8	1	Screw-HH	22	106-4556-01	1	Cover-Upper
2	92-7104	1	Pulley-Idler	23	32144-10	16	Screw-HWH
3	107-1047	1	Nut	24	108-0036	1	Bracket-Rod, Shift
4	107-1039	1	Bracket-Idler, Impeller	25	106-7268	1	Lever-Control, Traction
5	3296-42	3	Nut-Lock, NI	26	108-0026-01	1	Shift Plate ASM
6	3290-456	1	Washer-Belleville	27	106-7345-01	1	Cover-Lower
7	3296-59	2	Nut-Lock, NI	28	25-5640	1	Washer
8	322-3	1	Screw-HH	29	27-0410	1	Screw-Shoulder
9	107-3838-03	1	Impeller Clutch ASM	30	3272-4	1	Pin-Cotter
10	106-7341	1	Bracket-Rear, Clutch	31	3256-23	1	Washer-Flat
11	99-6810	2	Screw-HH	32	107-1011	1	Bellcrank-Drive
12	108-5056	1	Bolt-Shoulder	33	106-4467	1	Link-Control, Speed
13	108-5058	1	Arm-Idler, Traction	34	3290-307	1	Pin-Hair
14	3-4244	1	Pulley-Idler	35	32151-61	2	Ring-Retaining
15	108-7332	1	Spring-Torsion	36	256-257	2	Bushing-Nyliner
16	107-1013	2	Nut-Speed, U-Type	37	106-7330-01	1	Pan-Bottom
17	3234-7	2	Screw-HHF	38	112-8128	1	Frame Brace ASM
18	107-1045	1	Spring-Extension	39	107069	8	Clip
19	107-1003	1	Spring-Extension	40	108-0031	1	Traction Pulley ASM
20	3296-76	1	Nut-Lock, NI	41	108-7307	1	Friction Wheel Bracket ASM
21	5-4460	2	Washer-Pivot	42	3290-340	1	Washer-Belleville

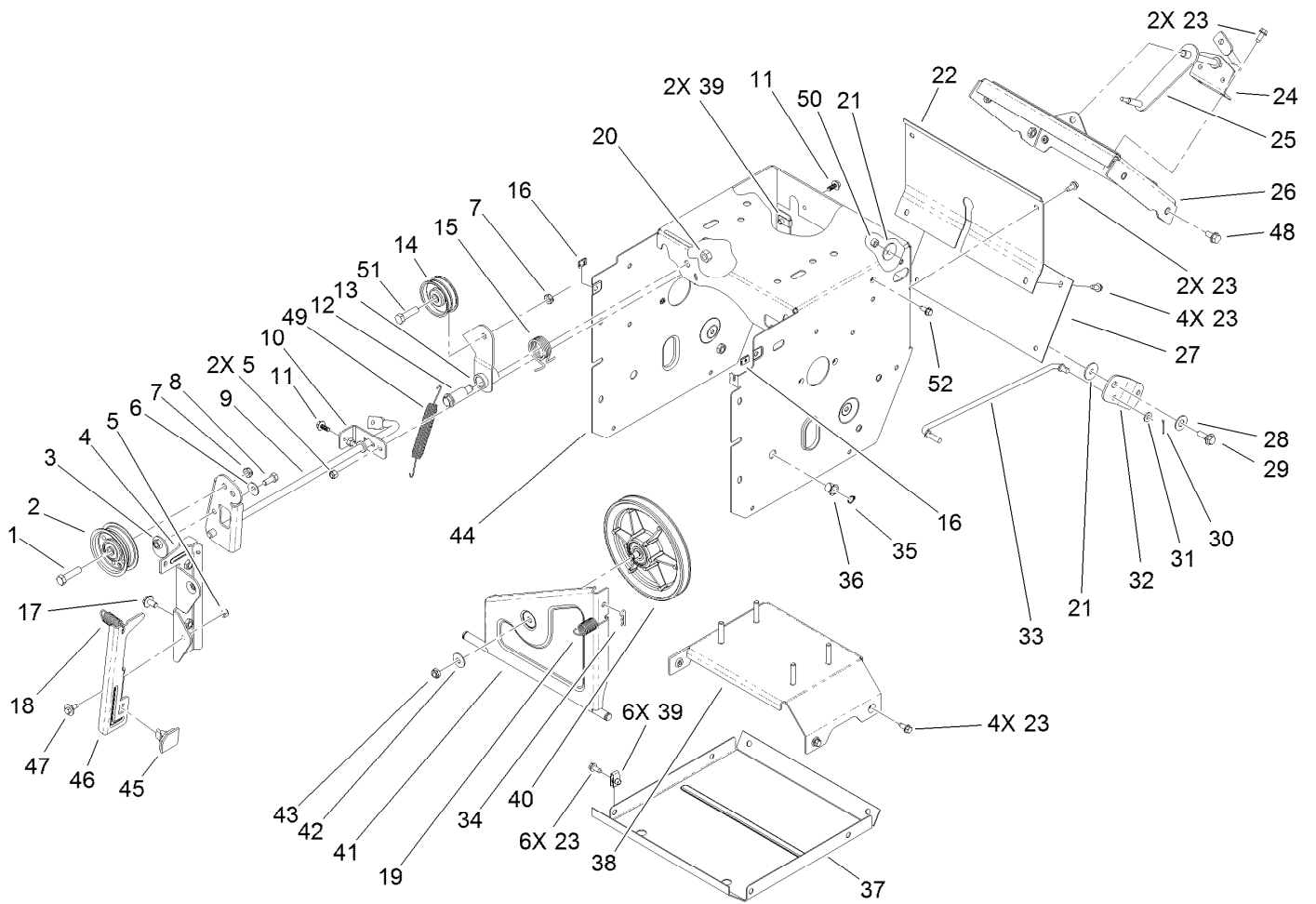

## Frame Assembly (continued)

<i>Ref.</i>	<i>Part Number</i>	<i>Qty.</i>	<i>Description</i>	<i>Ref.</i>	<i>Part Number</i>	<i>Qty.</i>	<i>Description</i>
43	3296-5	1	Nut-Lock	48	32144-14	4	Screw-HWHTF
44	120-9832-01	1	Traction Frame ASM	49	108-2976	1	Spring-Extension
45	66-8060	1	Pad-Brake	50	3296-29	1	Nut-Lock, NI
46	107-1000	1	Arm-Brake	51	323-29	1	Screw-HH
47	92-9698	1	Screw-Shoulder	52	32144-4	1	Screw-HWH

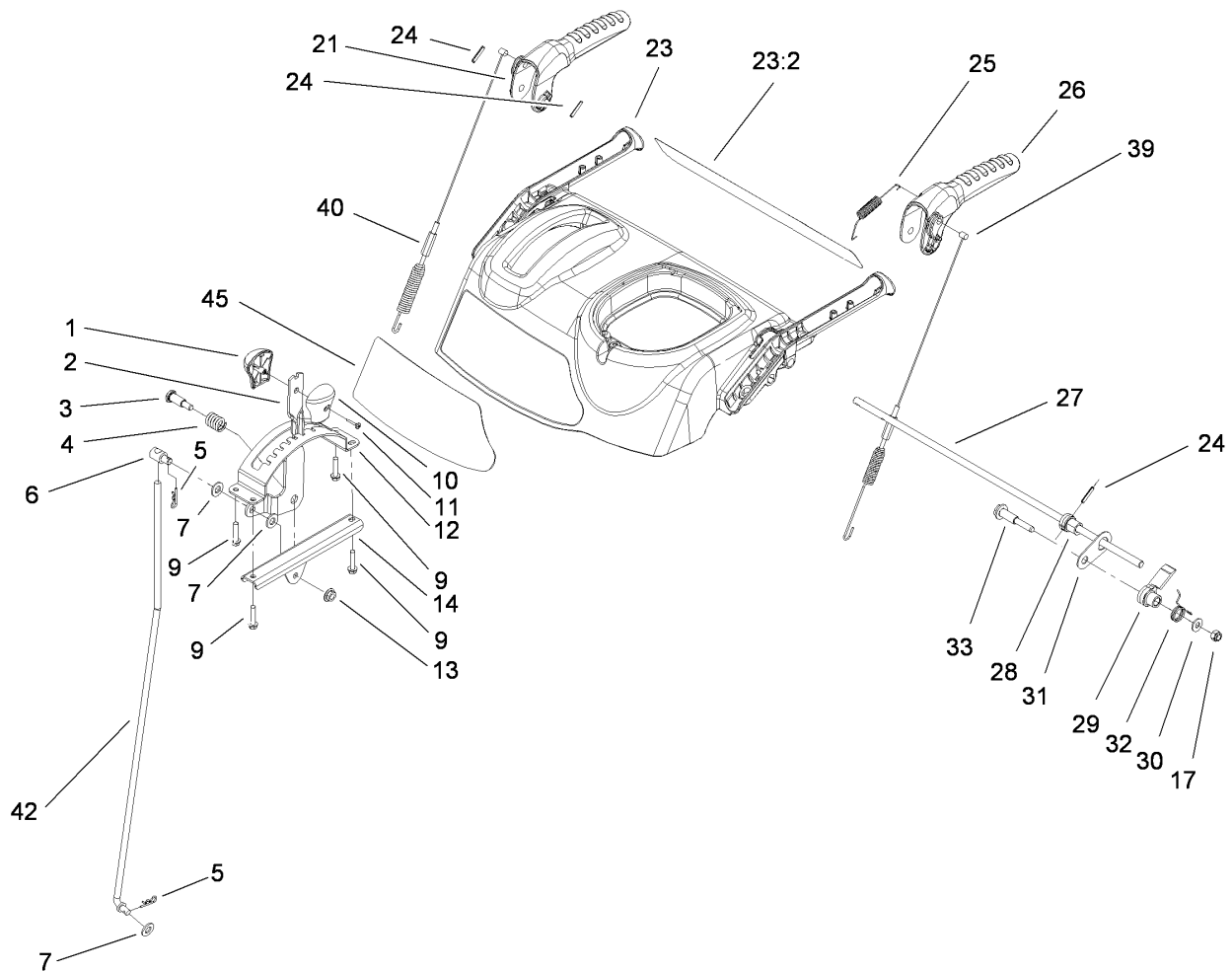

## Handle and Control Assembly

Ref.	Part Number	Qty.	Description	Ref.	Part Number	Qty.	Description
1	106-4423	1	Knob-Shift, RH	23:2	112-6626	1	Decal-Panel, Control
2	106-7278-03	1	Selector-Speed	24	32121-125	3	Pin-Spring
3	63-2650	1	Screw-Shoulder	25	107-3001	1	Spring-Tension
4	108-7313	1	Spring-Compression	26	106-4410	1	Lever-Traction
5	3290-307	2	Pin-Hair	27	105-9996	1	Rod-Lockout
6	110-3446	1	Trunion-Rod	28	107-1043	1	Cam-Lockout
7	3256-24	3	Washer-Flat	29	108-0023	1	Latch-Lockout
9	46-8092	4	Screw-Plastite	30	98-3499	1	Washer-Flat
10	105-9999	1	Knob-Shift, LH	31	107-3000	1	Link-Lockout
11	94-4496	1	Screw-PPH	32	108-0024	1	Spring-Torsion
12	106-7277-03	1	Guide-Selector, Speed	33	106-4412	1	Screw-Shoulder
13	32128-13	1	Nut-HHF	39	120-0132	1	Cable-Traction
14	106-7279-03	1	Mount-Selector, Speed	40	115-5680	1	Cable-Auger
17	3296-72	1	Nut-Lock, NI	42	107-1005	1	Rod-Shift
21	106-4413	1	Lever-Auger	45	112-8143	1	Decal-Control Panel
23	112-6631	1	Control Panel ASM				

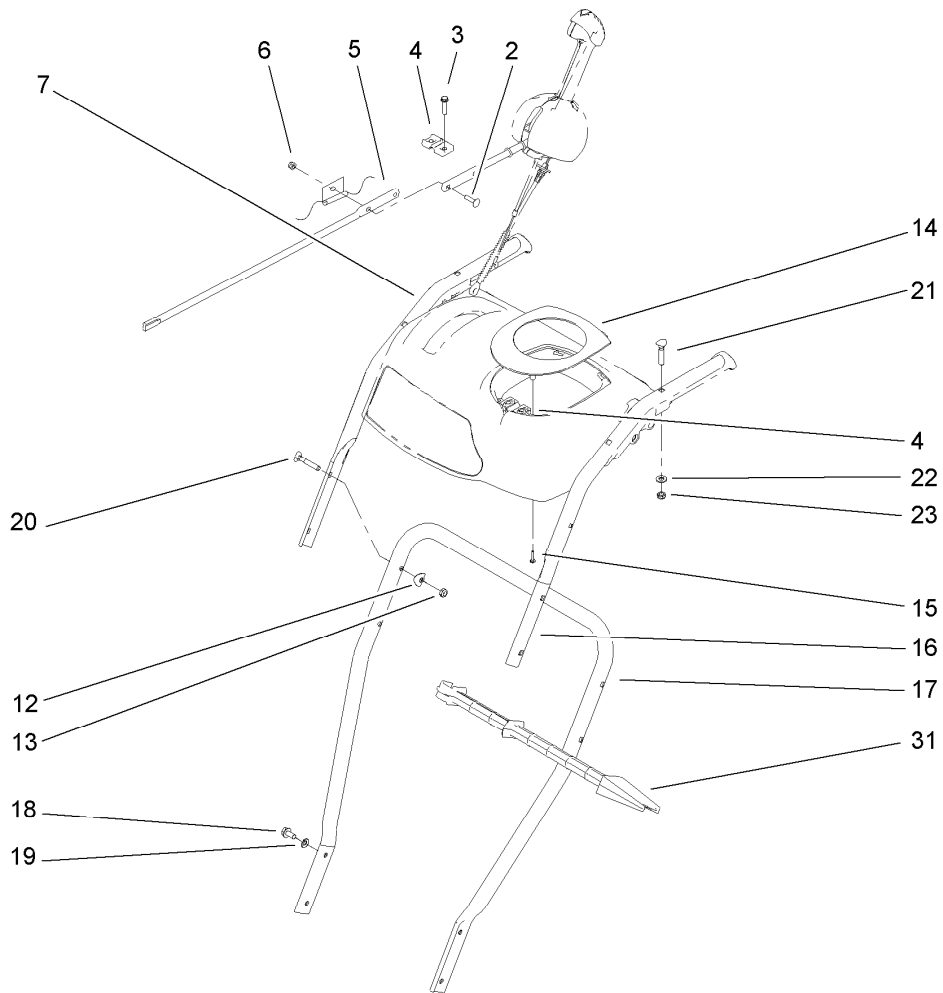

## Handle Assembly

<i>Ref.</i>	<i>Part Number</i>	<i>Qty.</i>	<i>Description</i>
2	3229-30	2	Screw-CARR
3	46-8092	2	Screw-Plastite
4	105-9987	2	Support-Rod
5	106-7283	1	Rod-Chute, Front
6	3296-73	2	Nut-Lock, NI
7	108-0038-03	1	Handle-Upper, RH
12	107-3844	4	Washer
13	3296-72	4	Nut-Lock, NI
14	106-4586	1	Cover-Panel, Control
15	94-4496	2	Screw-PPH
16	108-0037-03	1	Handle-Upper, LH
17	105-9981-03	1	Handle-Lower
18	32144-14	4	Screw-HWHTF
19	3290-475	4	Washer-Belleville
20	92-2260	4	Screw-Handle
21	107-3018	4	Screw-Handle
22	3256-70	4	Washer-Flat
23	3296-72	4	Nut-Lock, NI
31	110-3408	1	Stick-Cleanout

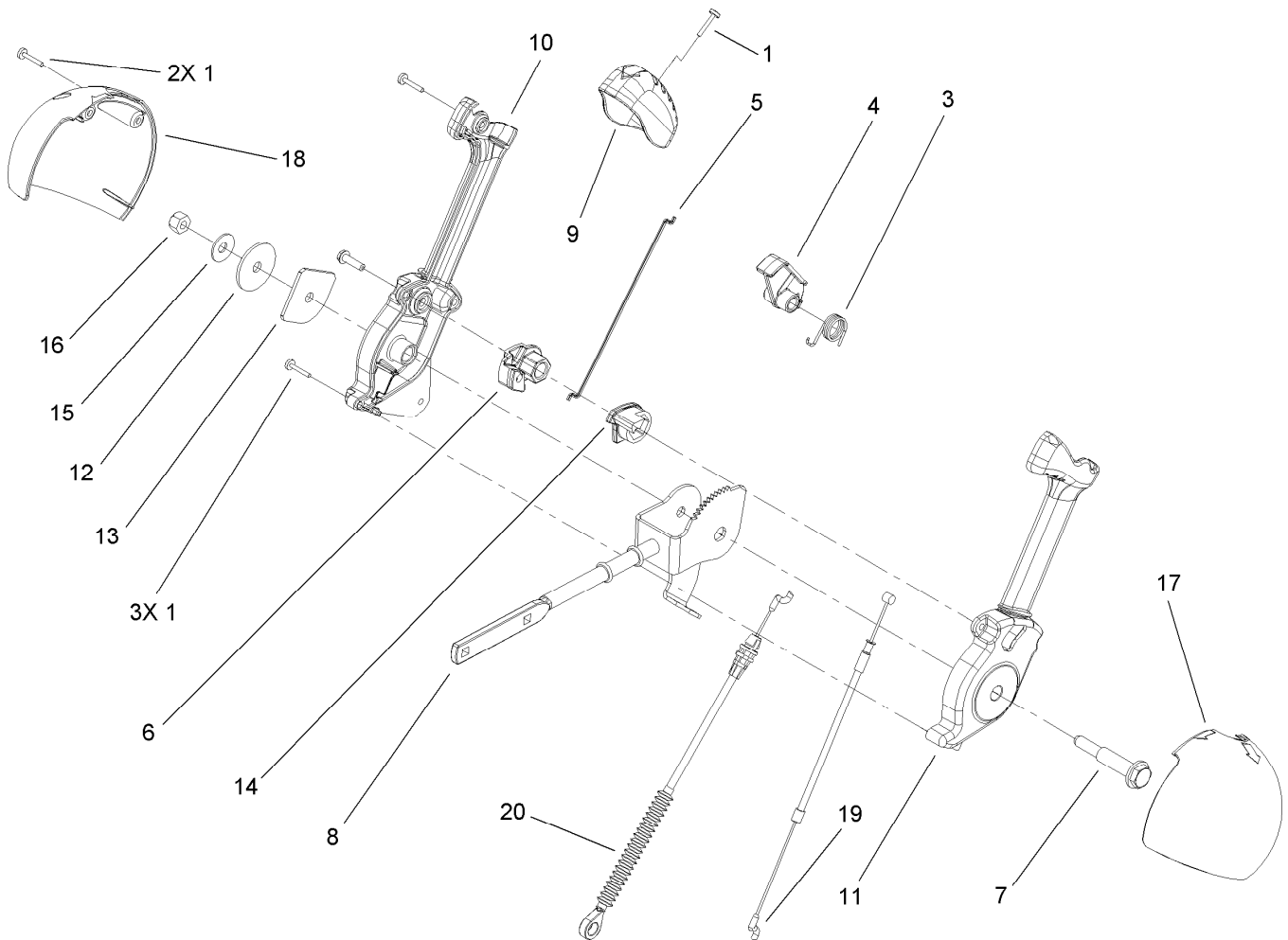

## Lever Chute Control Assembly

<b>Ref.</b>	<b>Part Number</b>	<b>Qty.</b>	<b>Description</b>
1	94-4496	6	Screw-PPH
3	105-9982	1	Spring-Torsion
4	105-9984	1	Trigger-Latch
5	105-9985	1	Link-Latch
6	105-9988	1	Lever-Cable, Deflector
7	105-9995	1	Screw-Shoulder
8	106-4479	1	Rod-Control, Chute
9	106-7280	1	Cap-Lever
10	106-7281	1	Lever-Chute Control, RH
11	106-7282	1	Lever-Chute Control, LH
12	107-3002	1	Washer-Nylon
13	106-7295	1	Plate-Friction
14	106-7310	1	Pawl-Latch
15	3290-456	1	Washer-Belleville
16	3296-29	1	Nut-Lock, NI
17	105-9986	1	Cover-Chute Lever, LH
18	106-7292	1	Cover-Chute Lever, RH
19	105-9989	1	Cable-Release, Chute
20	105-9990	1	Cable-Control, Deflector

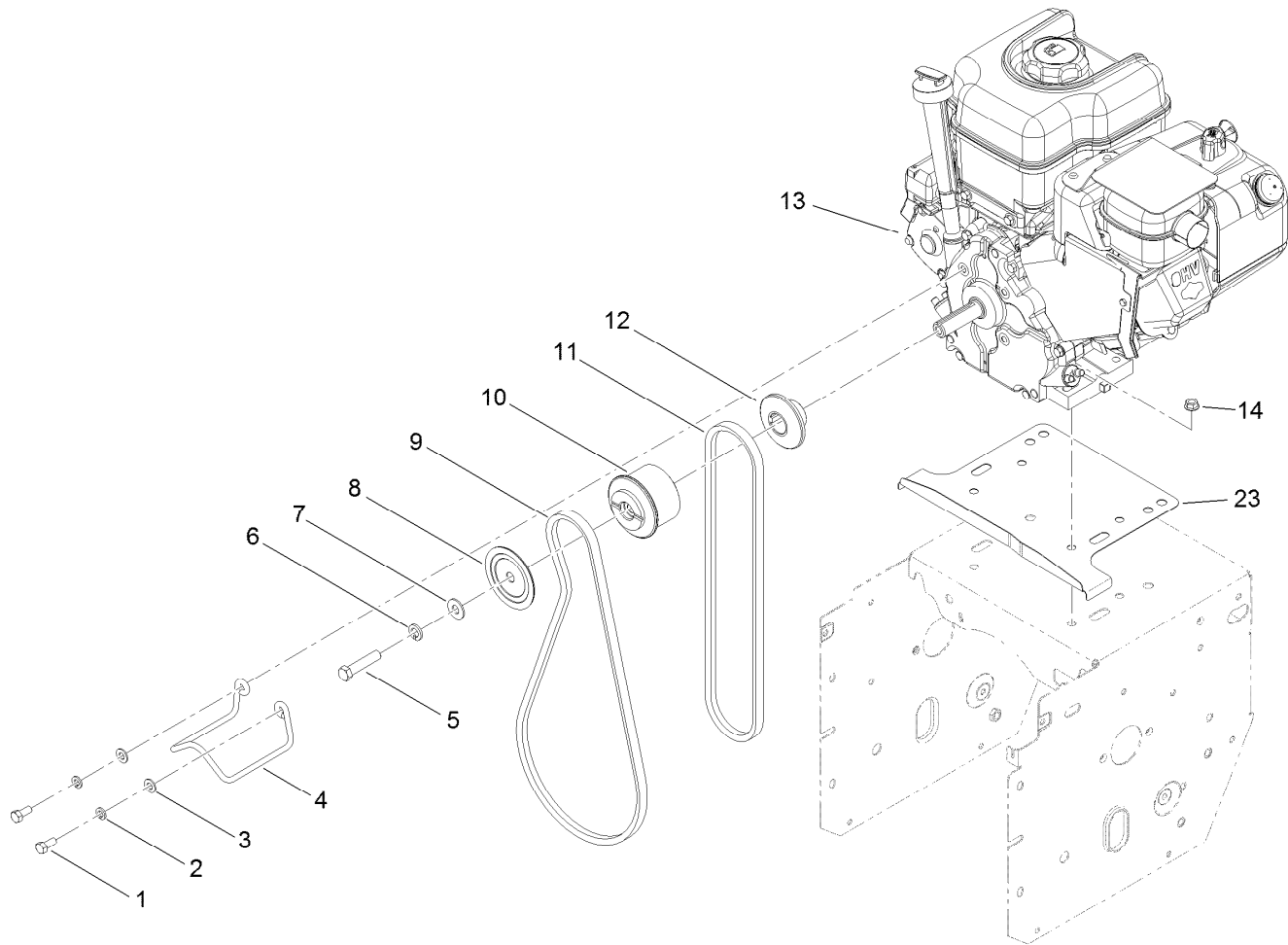

## Engine Assembly

Ref.	Part Number	Qty.	Description
1	3210-3	2	Screw-HH
2	3253-4	2	Washer-Lock
3	3256-23	2	Washer-Flat
4	107-3835	1	Guide-Belt
5	3211-9	1	Screw-HH
6	3253-21	1	Washer-Lock
7	3256-24	1	Washer-Flat
8	112-8139	1	Sheave-Half, Impeller
9	106-4498	1	Belt-V
10	112-8117	1	Pulley-Engine, Center
11	94-8812	1	V Belt-Traction
12	112-8138	1	Sheave-Half, Traction
13		1	Engine-Briggs, 15C1170157H8 ● ■
14	32128-20	4	Nut-HF
23	117-6022-01	1	Shield-Drive

● Not serviced separately

■ Obtain parts from [www.briggsandstratton.com](http://www.briggsandstratton.com)

# Attachments and Accessories

## For 38629 Power Max 826 OE Snowthrower

<b>Product Name</b>	<b>Model/Part</b>
Tire Chain Kit .....	107-3813
Snow Cab .....	107-3814
Weight Kit .....	107-3815
26 Inch Drift Breaker .....	107-3816
Light Kit.....	107-3827



**Count on it.**