



Count on it.

Operator's Manual

**TITAN ZX4820 and ZX5420
Zero-Turn-Radius Riding Mower**

Model No. 74920—Serial No. 311000001 and Up

Model No. 74924—Serial No. 311000001 and Up



g015469

This machine is a ride-on, rotary-blade lawnmower intended to be used by homeowners in residential applications. It is primarily designed for cutting grass on well-maintained lawns. It is not designed for cutting brush, mowing grass and other growth alongside highways, or for agricultural uses.

This product complies with all relevant European directives, for details please see the separate product specific Declaration of Conformity (DOC) sheet.

Introduction

Read this information carefully to learn how to operate and maintain your product properly and to avoid injury and product damage. You are responsible for operating the product properly and safely.

You may contact Toro directly at www.Toro.com for product and accessory information, help finding a dealer, or to register your product.

Whenever you need service, genuine Toro parts, or additional information, contact an Authorized Service Dealer or Toro Customer Service and have the model and serial numbers of your product ready. Figure 1 identifies the location of the model and serial numbers on the product. Write the numbers in the space provided.

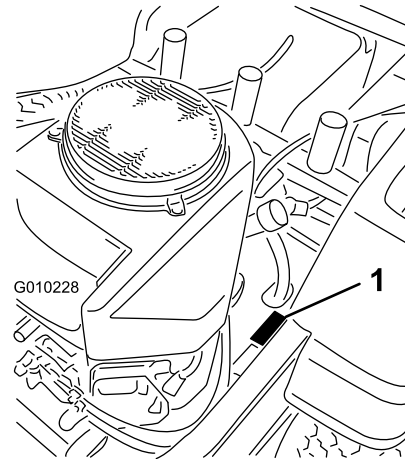

Figure 1

1. Model and serial number location

| |
|-------------------------|
| Model No. _____ |
| Serial No. _____ |

This manual identifies potential hazards and has safety messages identified by the safety alert symbol (Figure 2), which signals a hazard that may cause serious injury or death if you do not follow the recommended precautions.



Figure 2

1. Safety alert symbol

This manual uses 2 other words to highlight information. **Important** calls attention to special mechanical information and **Note** emphasizes general information worthy of special attention.

⚠ WARNING

Removing standard original equipment parts and accessories may alter the warranty, traction, and safety of the machine. Failure to use original Toro parts could cause serious injury or death. Making unauthorized changes to the engine, fuel or venting system, may violate EPA and CARB regulations.

Replace all parts including, but not limited to, tires, belts, blades, and fuel system components with original Toro parts.

For models with stated engine horsepower, the gross horsepower of the engine was laboratory rated by the engine manufacturer in accordance with SAE J1940. As configured to meet safety, emission, and operating requirements, the actual engine horsepower on this class of lawn mower will be significantly lower.

Do not tamper with the engine controls or alter the governor speed; doing so may create an unsafe condition resulting in personal injury.

Contents

| | |
|---|----|
| Introduction..... | 2 |
| Safety | 5 |
| Safe Operation Practices for Ride-on (riding) | |
| Rotary Lawnmower Machines..... | 5 |
| Safe Operating Practices | 5 |
| Toro Riding Mower Safety | 6 |
| Model 74920 | 7 |
| Model 74924 | 7 |
| Slope Indicator..... | 9 |
| Safety and Instructional Decals | 10 |
| Product Overview | 16 |
| Controls | 17 |
| Operation..... | 18 |
| Think Safety First..... | 18 |
| Using the Rollover Protection System (ROPS) | 19 |
| Adding Fuel | 19 |
| Checking the Engine Oil Level..... | 21 |
| Operating the Parking Brake | 21 |
| Operating the Throttle | 22 |
| Operating the Choke | 22 |
| Operating the Ignition Switch | 22 |
| Starting and Stopping the Engine | 23 |
| Operating the Mower Blade Control Switch (PTO) | 24 |
| The Safety Interlock System..... | 24 |
| Driving Forward or Backward..... | 25 |
| Stopping the Machine..... | 26 |
| Adjusting the Height of Cut..... | 26 |
| Adjusting the Anti-Scalp Rollers | 27 |
| Positioning the Seat | 27 |
| Adjusting the Motion Control Levers | 28 |
| Pushing the Machine by Hand..... | 28 |
| Converting the 48 inch Mower to Side Discharge..... | 29 |
| Converting the 54 inch Mower to Side Discharge..... | 30 |
| Using the Side Discharge | 32 |
| Operating Tips | 32 |
| Maintenance..... | 34 |
| Recommended Maintenance Schedule(s) | 34 |
| Premaintenance Procedures..... | 36 |
| Raising the Seat | 36 |
| Lubrication..... | 36 |
| Greasing the Bearings..... | 36 |
| Engine Maintenance..... | 37 |
| Servicing the Air Cleaner | 37 |
| Servicing the Engine Oil..... | 37 |
| Servicing the Spark Plug | 39 |
| Cleaning the Cooling System..... | 40 |
| Fuel System Maintenance | 41 |

| | |
|--|----|
| Replacing the Fuel Filter | 41 |
| Servicing the Emissions Filter..... | 41 |
| Electrical System Maintenance..... | 42 |
| Servicing the Battery..... | 42 |
| Servicing the Fuses | 43 |
| Drive System Maintenance | 44 |
| Checking the Tire Pressure | 44 |
| Hydraulic System Maintenance | 45 |
| Checking the Hydraulic Oil Level..... | 45 |
| Changing the Hydraulic System Filter and Oil..... | 45 |
| Mower Deck Maintenance | 47 |
| Servicing the Cutting Blades | 47 |
| Mower Deck Leveling..... | 49 |
| Inspecting the Belts | 51 |
| Replacing the Mower Belt | 51 |
| Removing the Mower | 52 |
| Installing the Mower..... | 52 |
| Replacing the Grass Deflector..... | 52 |
| Cleaning..... | 54 |
| Washing the Underside of the Mower | 54 |
| Waste Disposal..... | 55 |
| Storage | 55 |
| Cleaning and Storage | 55 |
| Troubleshooting..... | 57 |
| Schematics | 59 |

Safety

Safe Operation Practices for Ride-on (riding) Rotary Lawnmower Machines

This machine meets or exceeds European Standards in effect at the time of production. However, improper use or maintenance by the operator or owner can result in injury. To reduce the potential for injury, comply with these safety instructions and always pay attention to the safety alert symbol, which means CAUTION, WARNING, or DANGER -“personal safety instruction.” Failure to comply with the instruction may result in personal injury or death.

Safe Operating Practices

The following instructions are from the EN standard EN 836:1997.

This product is capable of amputating hands and feet and throwing objects. Always follow all safety instructions to avoid serious injury or death.

Training

- Read the instructions carefully. Be familiar with the controls and the proper use of the equipment.
- Never allow children or people unfamiliar with these instructions to use the lawnmower. Local regulations can restrict the age of the operator.
- Never mow while people, especially children, or pets are nearby.
- Keep in mind that the operator or user is responsible for accidents or hazards occurring to other people or their property.
- Do not carry passengers.
- All drivers should seek and obtain professional and practical instruction. Such instruction should emphasize:
 - the need for care and concentration when working with ride-on machines;
 - control of a ride-on machine sliding on a slope will not be regained by the application of the brake. The main reasons for loss of control are:
 - ◇ insufficient wheel grip;
 - ◇ being driven too fast;
 - ◇ inadequate braking;
 - ◇ the type of machine is unsuitable for its task;

- ◇ lack of awareness of the effect of ground conditions, especially slopes;
- ◇ incorrect hitching and load distribution.

Preparation

- While mowing, always wear substantial footwear and long trousers. Do not operate the equipment when barefoot or wearing open sandals.
- Thoroughly inspect the area where the equipment is to be used and remove all objects which may be thrown by the machine.
- Warning-Fuel is highly flammable.
 - Store fuel in containers specifically designed for this purpose.
 - Refuel outdoors only and do not smoke while refuelling.
 - Add fuel before starting the engine. Never remove the cap of the fuel tank or add fuel while the engine is running or when the engine is hot.
 - If fuel is spilled, do not attempt to start the engine but move the machine away from the area of spillage and avoid creating any source of ignition until fuel vapors have dissipated.
 - Replace all fuel tanks and container caps securely.
- Replace faulty silencers.
- Before using, always visually inspect to see that the blades, blade bolts and cutter assembly are not worn or damaged. Replace worn or damaged blades and bolts in sets to preserve balance.
- On multi-bladed machines, take care as rotating one blade can cause other blades to rotate.

Operation

- Be alert, slow down and use caution when making turns. Look behind and to the side before changing directions.
- Do not operate the engine in a confined space where dangerous carbon monoxide fumes can collect.
- Mow only in daylight or in good artificial light.
- Before attempting to start the engine, disengage all blade attachment clutches and shift into neutral.
- Do not use on slopes of more than 15 degrees.
- Remember there is no such thing as a safe slope. Travel on grass slopes requires particular care. To guard against overturning:
 - do not stop or start suddenly when going up or downhill;

- use low speeds on slopes and during tight turns;
- stay alert for humps and hollows and other hidden hazards;
- Use care when pulling loads.
 - Use only approved drawbar hitch points.
 - Limit loads to those you can safely control.
 - Do not turn sharply. Use care when reversing.
- Watch out for traffic when crossing or near roadways.
- Stop the blades rotating before crossing surfaces other than grass.
- When using any attachments, never direct discharge of material toward bystanders nor allow anyone near the machine while in operation.
- Never operate the machine with damaged guards or without safety protective devices in place.
- Do not change the engine governor settings or overspeed the engine. Operating the engine at excessive speed can increase the hazard of personal injury.
- Before leaving the operator's position:
 - disengage the power take-off and lower the attachments;
 - change into neutral and set the parking brake;
 - stop the engine and remove the key.
- Disengage drive to attachments, stop the engine, and disconnect the spark plug wire(s) or remove the ignition key.
 - before clearing blockages or unclogging chute;
 - before checking, cleaning or working on the lawnmower;
 - after striking a foreign object. Inspect the lawnmower for damage and make repairs before restarting and operating the equipment;
 - if the machine starts to vibrate abnormally (check immediately).
- Disengage drive to attachments when transporting or not in use.
- Stop the engine and disengage drive to attachment.
 - before refuelling;
 - before removing the grass catcher;
 - before making height adjustment unless adjustment can be made from the operator's position.

- Reduce the throttle setting during engine run-out and, if the engine is provided with a shut-off valve, turn the fuel off at the conclusion of mowing.
- Lightning can cause severe injury or death. If lightning is seen or thunder is heard in the area, do not operate the machine; seek shelter.

Maintenance and Storage

- Keep all nuts, bolts and screws tight to be sure the equipment is in safe working condition.
- Never store the equipment with fuel in the tank inside a building where fumes can reach an open flame or spark.
- Allow the engine to cool before storing in any enclosure.
- To reduce the fire hazard, keep the engine, silencer, battery compartment and fuel storage area free of grass, leaves, or excessive grease.
- Check the grass catcher frequently for wear or deterioration.
- Replace worn or damaged parts for safety.
- If the fuel tank has to be drained, this should be done outdoors.
- When machine is to be parked, stored or left unattended, lower the cutting means.

Toro Riding Mower Safety

The following list contains safety information specific to Toro products or other safety information that you must know that is not included in the CEN standard.

- Engine exhaust contains carbon monoxide, which is an odorless, deadly poison that can kill you. Do not run engine indoors or in an enclosed area.
- Keep hands, feet, hair and loose clothing away from attachment discharge area, underside of mower and any moving parts while engine is running.
- Do not touch equipment or attachment parts which may be hot from operation. Allow to cool before attempting to maintain, adjust, or service.
- Battery acid is poisonous and can cause burns. Avoid contact with skin, eyes and clothing. Protect your face, eyes, and clothing when working with a battery.
- Battery gases can explode. Keep cigarettes, sparks, and flames away from battery.
- Use only genuine Toro replacement parts to ensure that original standards are maintained.
- Use only Toro-approved attachments.

Slope Operation

- Do not mow slopes greater than 15 degrees.
- Do not mow near drop-offs, ditches, steep banks, or water. Wheels dropping over edges can cause rollovers, which may result in serious injury, death, or drowning.
- Do not mow slopes when grass is wet. Slippery conditions reduce traction and could cause sliding and loss of control.
- Do not make sudden turns or rapid speed changes.
- Use a walk behind mower and/or a hand trimmer near drop-offs, ditches, steep banks, or water.
- Reduce speed and use extreme caution on slopes.
- Remove or mark obstacles such as rocks, tree limbs, etc. from mowing area. Tall grass can hide obstacles.
- Watch for ditches, holes, rocks dips, and rises that change the operating angle, as rough terrain could overturn the machine.
- Avoid sudden starts when mowing uphill because the mower may tip backwards.
- Be aware that loss of traction may occur going downhill. Weight transfer to the front wheels may cause drive wheels to slip and cause loss of braking and steering.
- Always avoid sudden starting or stopping on a slope. If tires lose traction, disengage the blades and proceed slowly off the slope.
- Follow the manufacturer's recommendations for wheel weights or counterweights to improve stability.
- Use extreme care with grass catchers or other attachments. These can change the stability of the machine and cause loss of control.

Using the Rollover Protection System (ROPS)

- Keep the roll bar in the raised and locked position and use the seat belt when operating the machine.
- Be certain that the seat belt can be released quickly in the event of an emergency.
- Be aware there is no rollover protection when the roll bar is down.
- Check the area to be mowed and never fold the ROPS in areas where there are slopes, drop offs or water.

- Lower the rollbar only when absolutely necessary. Do not wear the seat belt with the roll bar folded down.
- Check carefully for overhead clearances (i.e. branches, doorways, electrical wires) before driving under any objects and do not contact them.

Model 74920

Sound Power

This unit has a guaranteed sound power level of 105 dBA, which includes an Uncertainty Value (K) of 1 dBA.

Sound power level was determined according to the procedures outlined in ISO 11094.

Sound Pressure

This unit has a sound pressure level at the operator's ear of 93 dBA, which includes an Uncertainty Value (K) of 1 dBA.

Sound power level was determined according to the procedures outlined in EN 836.

Hand-Arm Vibration

Measured vibration level for left hand = 2.4 m/s²

Measured vibration level for right hand = 2.6 m/s²

Uncertainty Value (K) = 1.3 m/s²

Measured values were determined according to the procedures outlined in EN 836.

Whole Body Vibration

Measured vibration level = 0.63 m/s²

Uncertainty Value (K) = 0.31 m/s²

Measured values were determined according to the procedures outlined in EN 836 (Riding & Stand-Ons).

Model 74924

Sound Power

This unit has a guaranteed sound power level of 105 dBA, which includes an Uncertainty Value (K) of 1 dBA.

Sound power level was determined according to the procedures outlined in ISO 11094.

Sound Pressure

This unit has a sound pressure level at the operator's ear of 93 dBA, which includes an Uncertainty Value (K) of 1 dBA.

Sound power level was determined according to the procedures outlined in EN 836.

Hand-Arm Vibration

Measured vibration level for left hand = 3.1 m/s²

Measured vibration level for right hand = 2.7 m/s²

Uncertainty Value (K) = 1.5 m/s²

Measured values were determined according to the procedures outlined in EN 836.

Whole Body Vibration

Measured vibration level = 0.71 m/s²

Uncertainty Value (K) = 0.35 m/s²

Measured values were determined according to the procedures outlined in EN 836 (Riding & Stand-Ons).

Slope Indicator

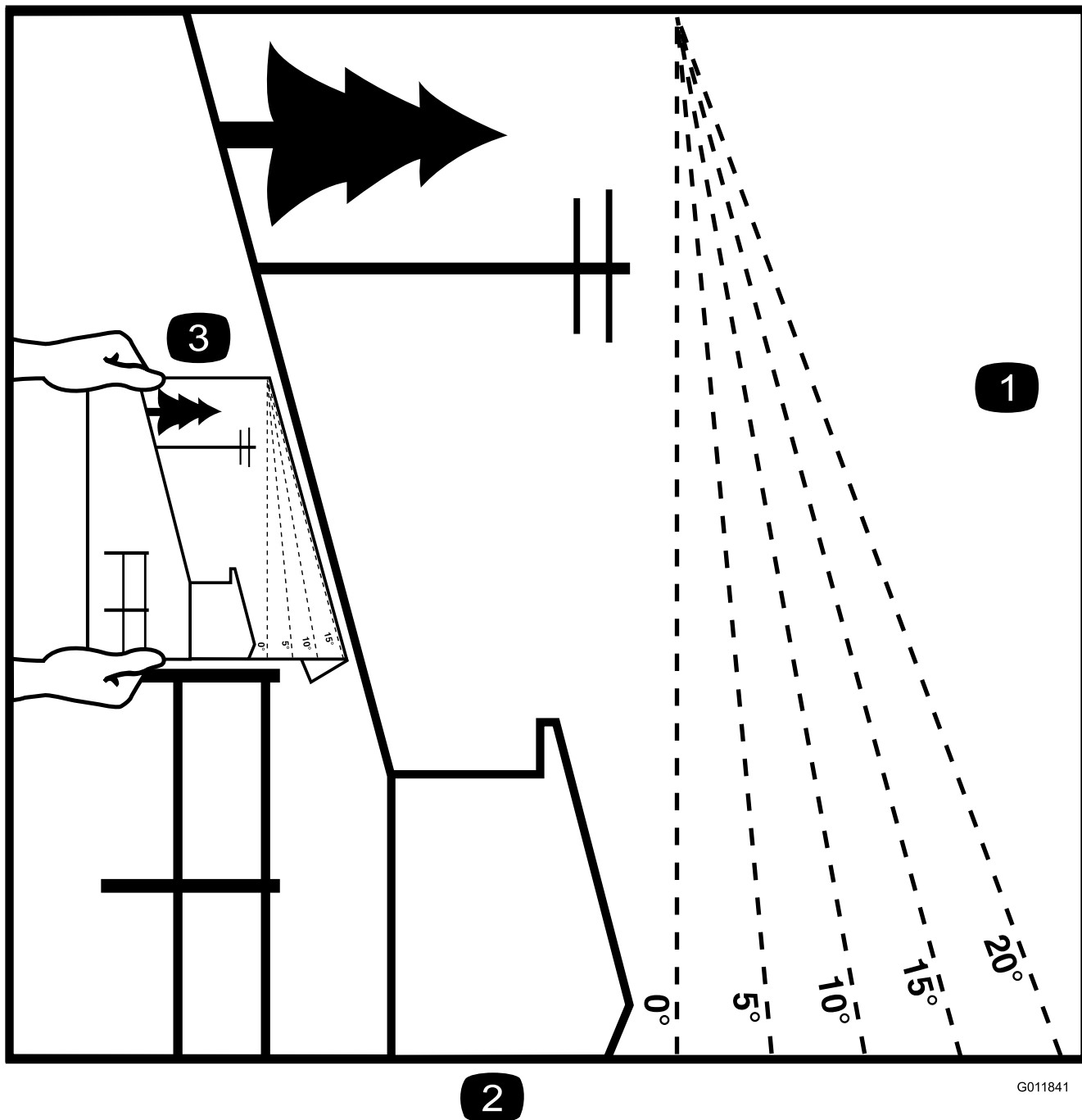

2

Figure 3

This page may be copied for personal use.

1. The maximum slope you can safely operate the machine on is **15 degrees**. Use the slope chart to determine the degree of slope of hills before operating. **Do not operate this machine on a slope greater than 15 degrees**. Fold along the appropriate line to match the recommended slope.
2. Align this edge with a vertical surface, a tree, building, fence pole, etc.
3. Example of how to compare slope with folded edge.

Safety and Instructional Decals



Safety decals and instructions are easily visible to the operator and are located near any area of potential danger. Replace any decal that is damaged or lost.

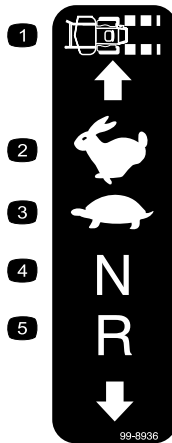

99-8936

- | | |
|------------------|------------|
| 1. Machine speed | 4. Neutral |
| 2. Fast | 5. Reverse |
| 3. Slow | |

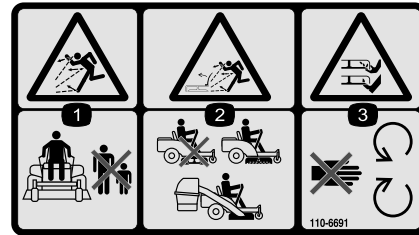

110-6691

1. Thrown object hazard—keep bystanders a safe distance from the machine.
2. Thrown object hazard, mower—do not operate without the deflector, discharge cover, or grass collection system in place.
3. Cutting/dismemberment of hand or foot—stay away from moving parts.

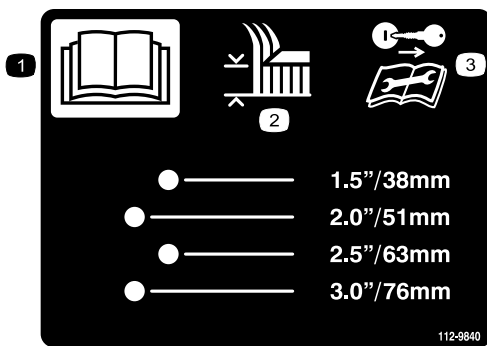

112-9840

- | | |
|--|--|
| 1. Read the <i>Operator's Manual</i> . | 3. Remove the ignition key and read the instructions before servicing or performing maintenance. |
| 2. Height of cut | |

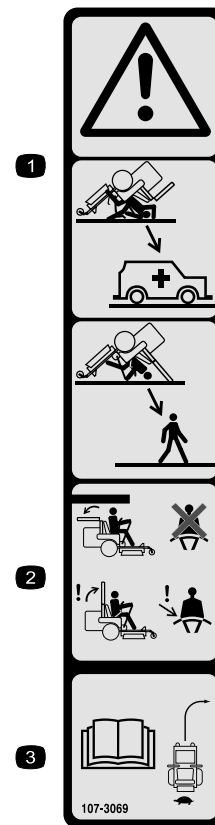

107-3069

1. Warning—there is no rollover protection when the roll bar is down.
2. To avoid injury or death from a rollover accident, keep the roll bar in the raised and locked position and wear the seat belt. Lower the roll bar only when absolutely necessary; do not wear the seat belt when the roll bar is down.
3. Read the *Operator's Manual*; drive slowly and carefully.

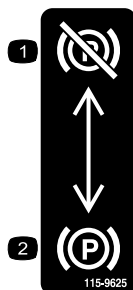

115-9625

- | | |
|-----------------------------|--------------------------|
| 1. Parking brake—disengaged | 2. Parking brake—engaged |
|-----------------------------|--------------------------|

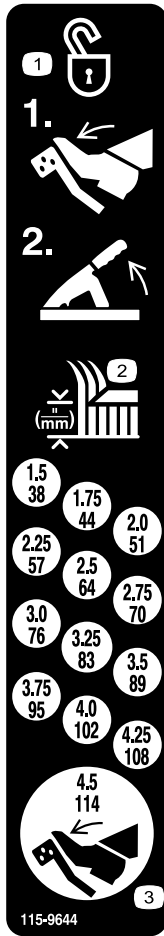

115-9644

1. Press the pedal and lift the height of cut lever to unlock the deck position.
2. Height of cut
3. Press the pedal to move the deck to the transport position

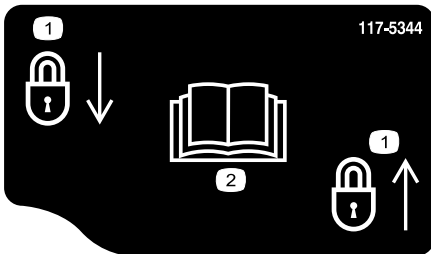

117-5344

1. Lock
2. Read the *Operator's Manual*



93-7009

1. Warning—do not operate the mower with the deflector up or removed; keep the deflector in place.
2. Cutting/dismemberment hazard of hand or foot, mower blade—stay away from moving parts.



Battery Symbols

Some or all of these symbols are on your battery

1. Explosion hazard
2. No fire, open flame, or smoking.
3. Caustic liquid/chemical burn hazard
4. Wear eye protection.
5. Read the *Operator's Manual*.
6. Keep bystanders a safe distance from the battery.
7. Wear eye protection; explosive gases can cause blindness and other injuries.
8. Battery acid can cause blindness or severe burns.
9. Flush eyes immediately with water and get medical help fast.
10. Contains lead; do not discard.

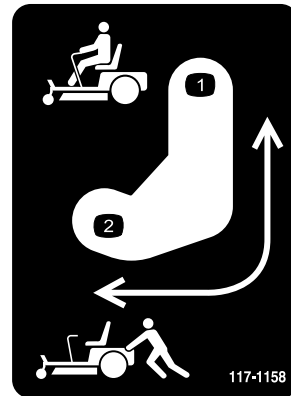

117-1158

1. Bypass lever position for operating the machine
2. Bypass lever position for pushing the machine

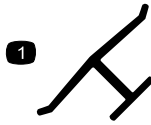

Manufacturer's Mark

1. Indicates the blade is identified as a part from the original machine manufacturer.

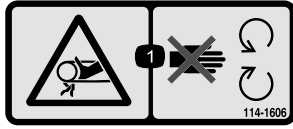

114-1606

1. Entanglement hazard, belt—keep all guards in place.

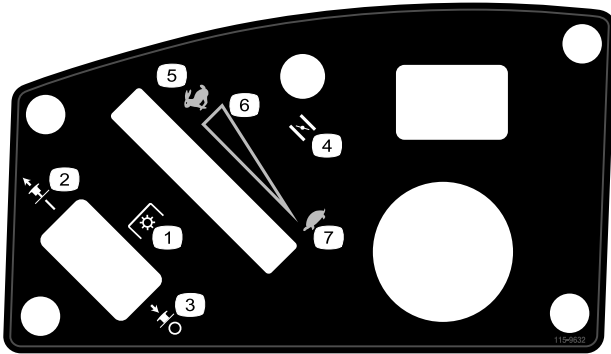

115-9632

- | | |
|--|-----------------------------------|
| 1. Power take-off (PTO), Blade control switch on some models | 5. Fast |
| 2. Blade control switch—On | 6. Continuous variable setting |
| 3. Blade control switch—Off | 7. Slow |
| 4. Choke | |

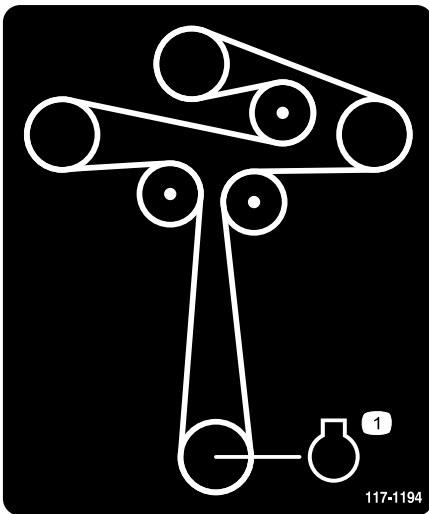

117-1194

1. Engine

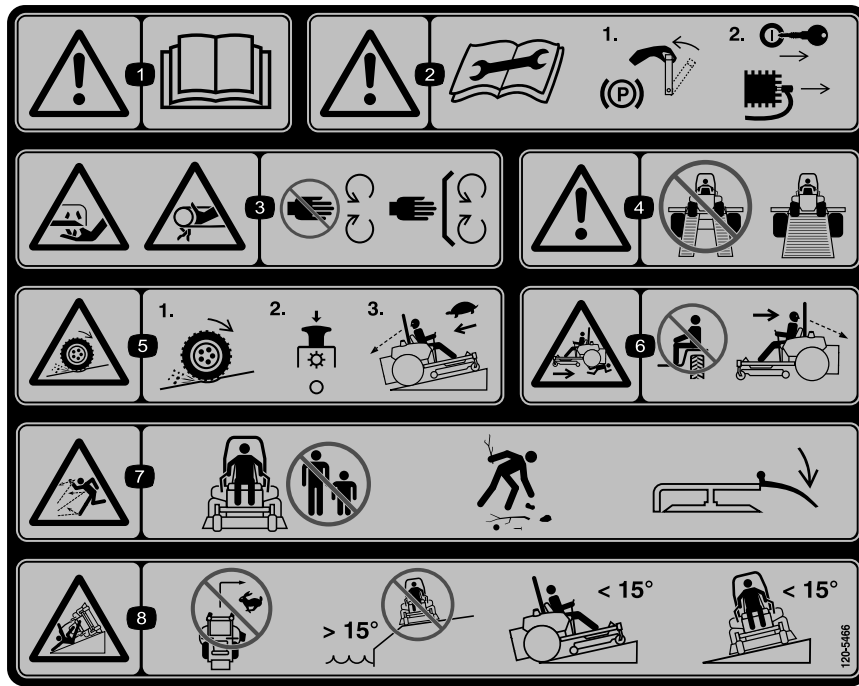

120-5466

1. Warning—read the *Operator's Manual*.
2. Warning—read the instructions before servicing or performing maintenance; move the motion control levers to the park (brake) position, remove the ignition key and disconnect the spark plug wire.
3. Cutting/dismemberment hazard, mower blade; entanglement hazard, belt—stay away from moving parts, keep all guards and shields in place.
4. Warning—do not use split ramps, use a full ramps when transporting machine.
5. Loss of traction/control hazard, slopes—loss of traction/control on a slope, disengage the blade control switch (PTO), proceed off the slope slowly.
6. Crushing/dismemberment hazard of bystanders, reversing—do not carry passengers, look behind and down when reversing.
7. Thrown object hazard—keep bystanders a safe distance from the machine, pick up debris before operating, keep deflector in place.
8. Tipping hazard—do not turn at high speeds, do not operate near drop-offs on slopes greater than 15 degrees, do not mow slopes greater than 15 degrees, avoid sudden and sharp turns while on slopes.

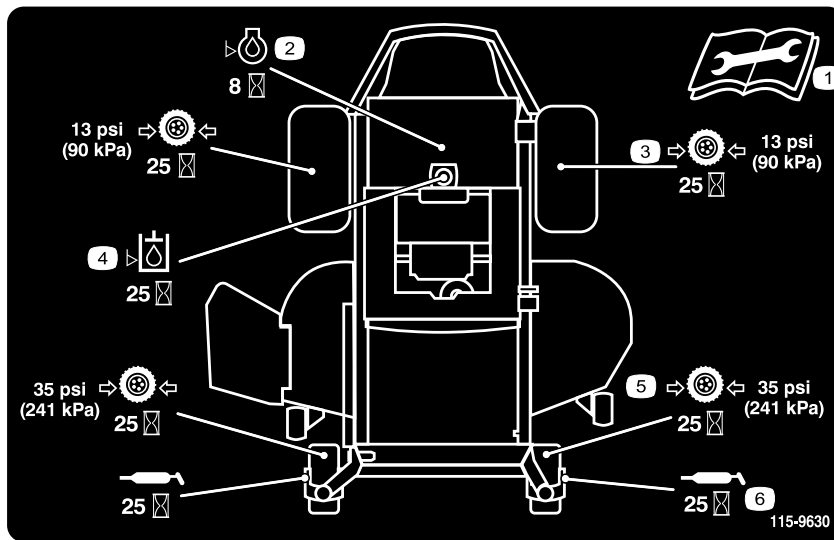

115-9630

1. Read the *Operator's Manual* before performing any maintenance.
2. Check the engine oil every 8 hours
3. Check the drive wheel tire pressure every 25 hours
4. Check the hydraulic oil every 25 hours
5. Check the caster wheel tire pressure every 25 hours
6. Lubricate the caster wheel every 25 hours



119-8983

1. Fuel
2. Full
3. Half
4. Empty



119-8986

1. Fuel

2. Full

3. Half

4. Empty

Product Overview

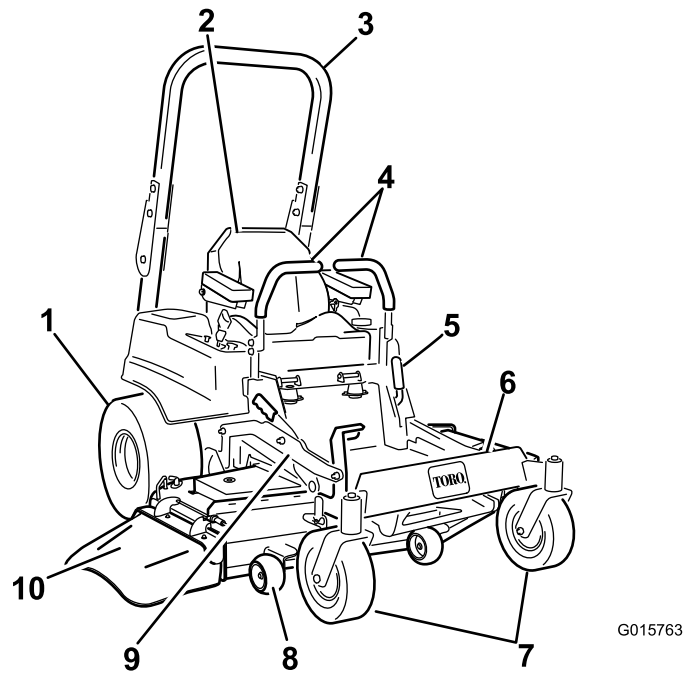

Figure 4

- | | | | |
|---------------------------------------|--------------------------|---|---------------|
| 1. Drive wheel | 4. Motion control levers | 7. Front caster wheel | 10. Deflector |
| 2. Operator seat | 5. Parking brake | 8. Anti-scalp roller | |
| 3. Roll over protection system (ROPS) | 6. Footrest | 9. Foot pedal deck lift and height-of-cut | |

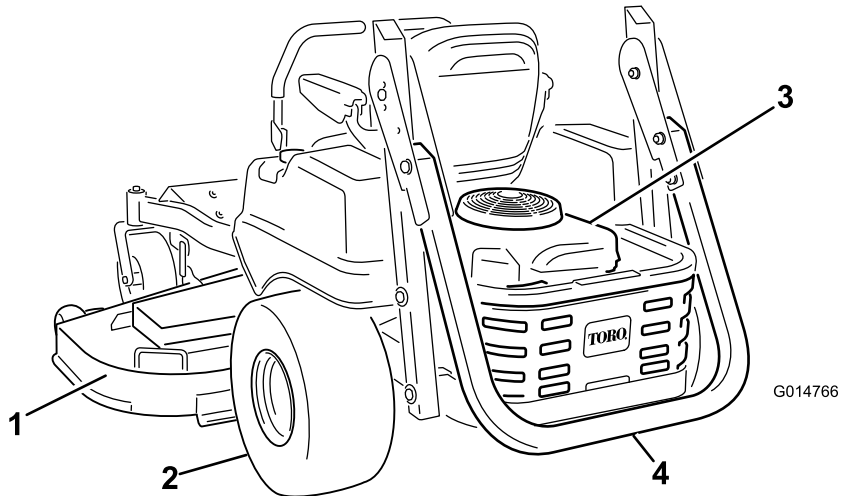

Figure 5

- | | |
|----------------|--|
| 1. Mower Deck | 3. Engine |
| 2. Drive wheel | 4. Roll over protection system (ROPS), folded down |

Controls

Become familiar with all the controls before you start the engine and operate the machine (Figure 6).

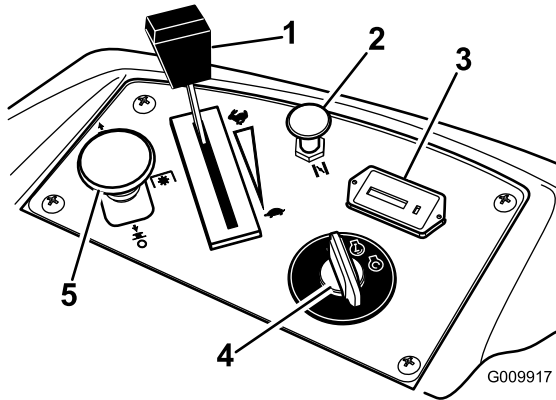

Figure 6

- | | |
|---------------------|-------------------------------|
| 1. Throttle control | 4. Ignition switch |
| 2. Choke | 5. Blade control switch (PTO) |
| 3. Hour meter | |

Ignition Switch

The ignition switch has three positions: **Start**, **Run** and **Off**. The key will turn to Start and move back to Run upon release. Turning the key to the Off position will stop the engine; however, always remove the key when leaving the machine to prevent the engine from accidentally starting (Figure 6).

Throttle Control

The throttle control is variable between **Fast** and **Slow**. Moving throttle lever forward will increase engine speed and moving throttle lever to the rear will decrease engine speed. Moving the throttle forward into the detent is full throttle (Figure 6).

Choke

Use the choke to start a cold engine. Pull the choke knob up to engage it. Push down on the choke knob to disengage it.

Blade Control Switch (Power Take-Off)

The blade control switch, represented by a power take-off (PTO) symbol, engages and disengages power to the mower blades (Figure 6).

Hour Meter

The hour meter records the number of hours the blades have operated. It operates when the blade control

switch (PTO) is engaged. Use these times for scheduling regular maintenance (Figure 6).

Fuel Gauge

The fuel window located below the operator position can be used to verify the level of gasoline in the tank (Figure 7).

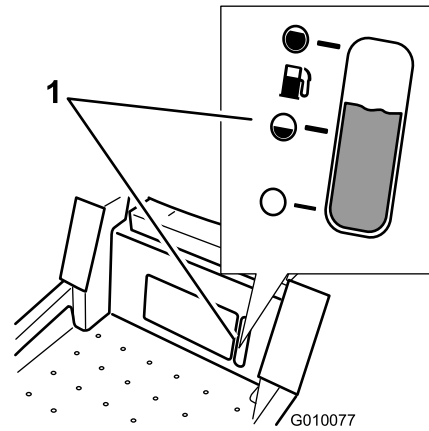

Figure 7

1. Fuel gauge window

Motion Control Levers

The motion control levers are speed sensitive controls of independent wheel motors. Moving a lever forward or backward turns the wheel on the same side forward or in reverse; wheel speed is proportional to the amount the lever is moved. Move the control levers outward from the center to the neutral lock position and exit the machine (Figure 4). Always position the motion control levers into the neutral lock position when you stop the machine or leave it unattended.

Parking Brake Lever

Located on left side of the console (Figure 4). The brake lever engages a parking brake on the drive wheels. Pull the lever up and rearward to engage the brake. Push the lever forward and down to disengage the brake.

Foot Pedal Deck Lift System

The foot pedal deck lift system allows the operator to lower and raise the deck from the seated position. The operator can use the foot pedal to lift the deck briefly to avoid obstacles or lock the deck in the highest height-of-cut or transport position (Figure 4).

Height-of-Cut Lever

The height-of-cut lever works with the foot pedal to lock the deck in a specific cutting height. Only adjust the height of cut while machine is not moving (Figure 4).

Attachments/Accessories

A selection of Toro approved attachments and accessories are available for use with the machine to enhance and expand its capabilities. Contact your Authorized Service Dealer or Distributor or go to www.Toro.com for a list of all approved attachments and accessories.

Operation

Note: Determine the left and right sides of the machine from the normal operating position.

Think Safety First

Please carefully read all of the safety instructions and decals in the safety section. Knowing this information could help you, your family, pets or bystanders avoid injury.

⚠ DANGER

Mowing on wet grass or steep slopes can cause sliding and loss of control.

Wheels dropping over edges can cause rollovers, which may result in serious injury, death or drowning.

A loss of traction is a loss of steering control.

To avoid loss of control and possibility of rollover:

- Do not mow near drop-offs or near water.
- Do not mow slopes greater than 15 degrees.
- Reduce speed and use extreme caution on slopes.
- When mowing slopes, gradually work from lower to higher areas on the incline.
- Avoid sudden turns or rapid speed changes.
- Turn up, into an incline when changing directions on slopes. Turning down the slope reduces traction.
- Attachments change the handling characteristics of the machine. Use extra caution when using attachments with the machine.

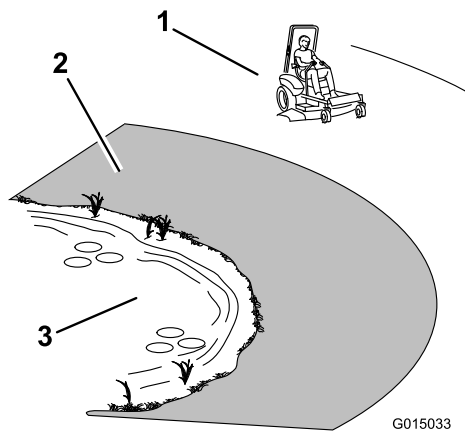

Figure 8

1. Safe Zone-use the machine here
2. Use walk behind mower and/or hand trimmer near drop-offs and water.
3. Water

Using the Rollover Protection System (ROPS)

⚠ WARNING

To avoid injury or death from rollover: keep the roll bar in the raised locked position and use the seat belt.

⚠ WARNING

There is no rollover protection when the roll bar is in the down position.

- Lower the roll bar only when absolutely necessary.
- Do not wear the seat belt when the roll bar is in the down position.
- Drive slowly and carefully.
- Raise the roll bar as soon as clearance permits.
- Check carefully for overhead clearances (i.e. branches, doorways, electrical wires) before driving under any objects and do not contact them.

Important: Lower the roll bar only when absolutely necessary.

1. To raise the roll bar, remove the hair cotter pin and remove the locking pins.
2. Raise the roll bar to the upright position (Figure 9).

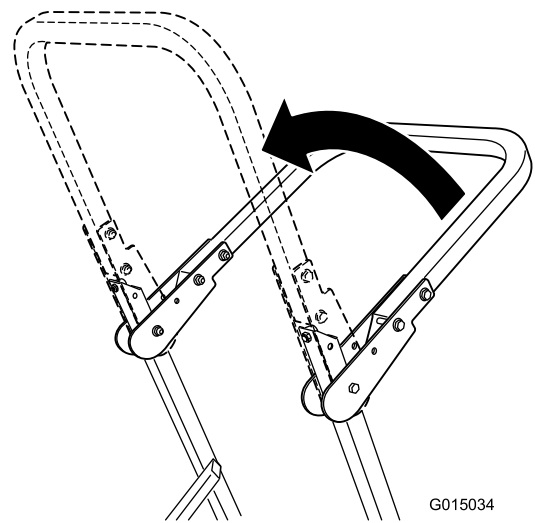

Figure 9

Important: Always use the seat belt with the roll bar in the raised position.

3. Install the locking pins. Secure the pins by installing the hair cotter pin (Figure 10).

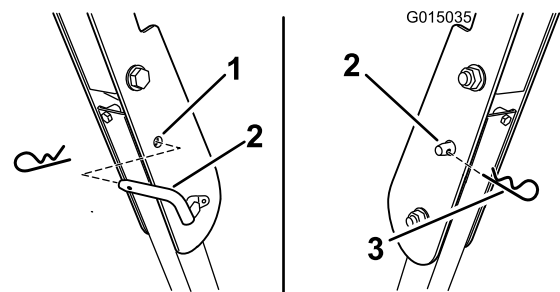

Figure 10

1. Hole in ROPS
2. Locking pin
3. Hair pin cotter

4. To lower the roll bar, remove the hair cotter pin and remove the locking pin.(Figure 10).
5. Lower the roll bar to the down position.
6. Use the two locking and cotter pins to secure the bar.

Adding Fuel

Use **unleaded** regular gasoline suitable for automotive use (85 pump octane minimum). Leaded regular gasoline may be used if unleaded regular is not available.

Important: Never use methanol or gasoline containing methanol because the fuel system could be damaged. Do not mix oil with gasoline.

Important: Some fuels, called oxygenated or reformulated gasoline, are gasoline blended with alcohols or ethers. Excessive amounts of

these blends can damage the fuel system or cause performance problems. If any undesirable operating symptoms occur, use gasoline with a lower percentage of alcohol or ether.

⚠ DANGER

In certain conditions during fueling, static electricity can be released causing a spark which can ignite the gasoline vapors. A fire or explosion from gasoline can burn you and others and can damage property.

- Always place gasoline containers on the ground away from your vehicle before filling.
- Do not fill gasoline containers inside a vehicle or on a truck or trailer bed because interior carpets or plastic truck bed liners may insulate the container and slow the loss of any static charge.
- When practical, remove gas-powered equipment from the truck or trailer and refuel the equipment with its wheels on the ground.
- If this is not possible, then refuel such equipment on a truck or trailer from a portable container, rather than from a gasoline dispenser nozzle.
- If a gasoline dispenser nozzle must be used, keep the nozzle in contact with the rim of the fuel tank or container opening at all times until fueling is complete.

⚠ WARNING

Gasoline is harmful or fatal if swallowed. Long-term exposure to vapors can cause serious injury and illness.

- Avoid prolonged breathing of vapors.
- Keep face away from nozzle and gas tank or conditioner opening.
- Keep gas away from eyes and skin.

⚠ DANGER

In certain conditions, gasoline is extremely flammable and highly explosive. A fire or explosion from gasoline can burn you and others and can damage property.

- Fill the fuel tank outdoors, in an open area, when the engine is cold. Wipe up any gasoline that spills.
- Never fill the fuel tank inside an enclosed trailer.
- Do not fill the fuel tank completely full. Add gasoline to the fuel tank until the level is 1/4 to 1/2 inch (6 to 13 mm) below the bottom of the filler neck. This empty space in the tank allows gasoline to expand.
- Never smoke when handling gasoline, and stay away from an open flame or where gasoline fumes may be ignited by a spark.
- Store gasoline in an approved container and keep it out of the reach of children. Never buy more than a 30-day supply of gasoline.
- Do not operate without entire exhaust system in place and in proper working condition.

Using Stabilizer/Conditioner

Use a fuel stabilizer/conditioner in the machine to provide the following benefits:

- Keeps gasoline fresh during storage of 90 days or less. For longer storage it is recommended that the fuel tank be drained.
- Cleans the engine while it runs
- Eliminates gum-like varnish buildup in the fuel system, which causes hard starting

Important: Do not use fuel additives containing methanol or ethanol.

Add the correct amount of gas stabilizer/conditioner to the gas.

Note: A fuel stabilizer/conditioner is most effective when mixed with fresh gasoline. To minimize the chance of varnish deposits in the fuel system, use fuel stabilizer at all times.

Fuel Gauge

Use the fuel window below the operator to verify the level of gasoline before filling the tank (Figure 11).

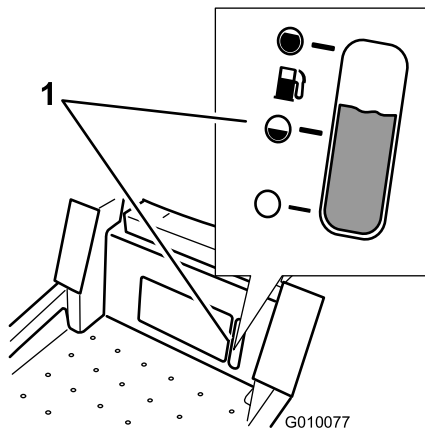

Figure 11

1. Fuel gauge window

Filling the Fuel Tank

Make sure the engine is shut off and the motion controls are in the park position.

Important: Do Not overfill fuel tank. Fill the fuel tank to the bottom of the filler neck. The empty space in the tank allows the fuel to expand. Overfilling may result in fuel leakage or damage to the engine or emission system.

1. Clean around the fuel tank cap and remove the cap.

Note: You can use the fuel window below the operating position verify the presence of gasoline before filling the tank (Figure 11).

2. **Slowly** add regular, unleaded gasoline until the fuel reaches the base of the filler neck Figure 12.

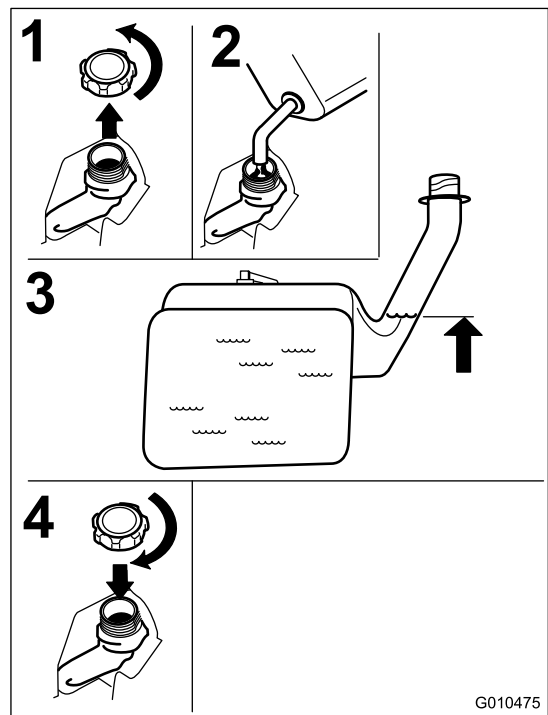

Figure 12

3. Install the fuel tank cap securely and tighten until it “clicks”. Wipe up any gasoline that may have spilled.

Checking the Engine Oil Level

Before you start the engine and use the machine, check the oil level in the engine crankcase; refer to Checking the Engine Oil Level.

Operating the Parking Brake

Always set the parking brake when you stop the machine or leave it unattended.

Setting the Parking Brake

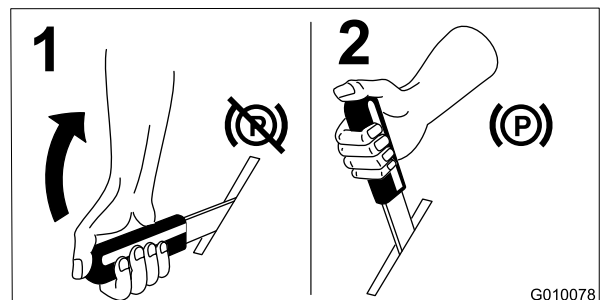

Figure 13

Releasing the Parking Brake

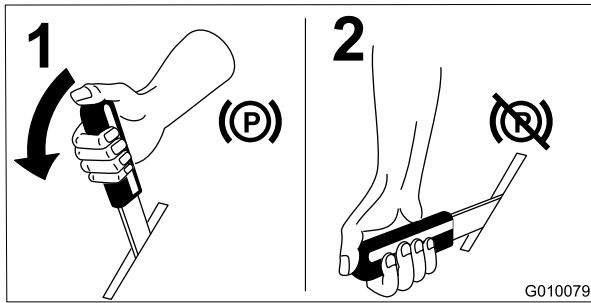

Figure 14

Operating the Throttle

The throttle control can be moved between **Fast** and **Slow** positions (Figure 15).

Always use the fast position when turning on the mower deck with the blade control switch (PTO).

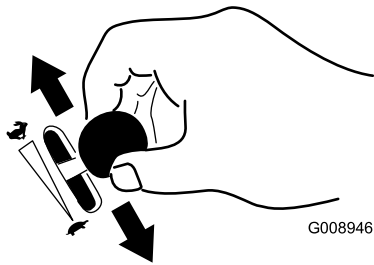

Figure 15

Operating the Choke

Use the choke to start a cold engine.

1. If the engine is cold, use the choke to start the engine.
2. Pull up on the choke knob to engage the choke before using the ignition switch (Figure 16).
3. Push down on the choke to disengage the choke after the engine has started (Figure 16).

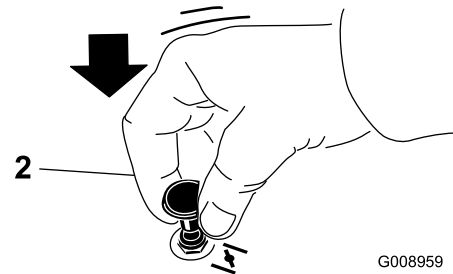
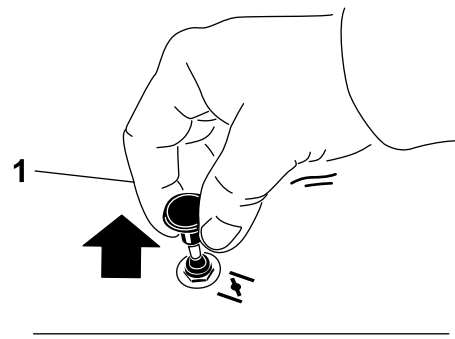

Figure 16

1. On

2. Off

Operating the Ignition Switch

1. Turn the ignition key to the Start position (Figure 17). When the engine starts, release the key.

Important: Do not engage starter for more than 5 seconds at a time. If the engine fails to start allow a 15 second cool-down period between attempts. Failure to follow these instructions can burn out the starter motor.

Note: Additional starting cycles may be required when starting the engine for the first time after the fuel system has been without fuel completely.

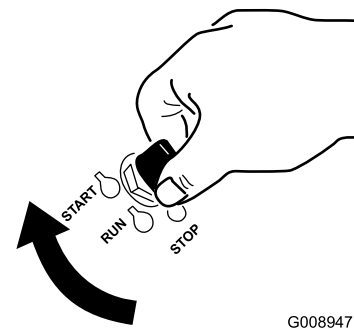

Figure 17

2. Turn the ignition key to stop to stop the engine.

Starting and Stopping the Engine

Starting the Engine

1. Sit down on the seat (Figure 18) and fasten the seat belt.
2. Move the motion controls outward to the neutral lock position (Figure 18).
3. Set the parking brake (Figure 18); refer to Setting the Parking Brake.
4. Move the blade control switch (PTO) to the Off position (Figure 18).
5. Move the throttle lever to Fast.
6. Engage the choke as described in Operating the Choke.

Note: A warm or hot engine may not require choking. In this case, first try starting the engine without using the choke.

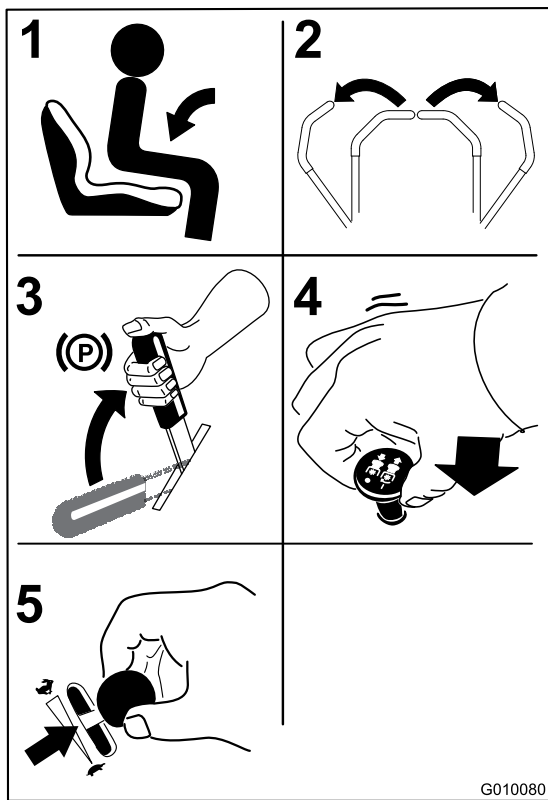

Figure 18

7. Turn the ignition key to the Start position (Figure 17). When the engine starts, release the key.

Important: Do not engage starter for more than 5 seconds at a time. If the engine fails to start allow a 15 second cool-down period

between attempts. Failure to follow these instructions can burn out the starter motor.

Note: Additional starting cycles may be required when starting the engine for the first time after the fuel system has been without fuel completely.

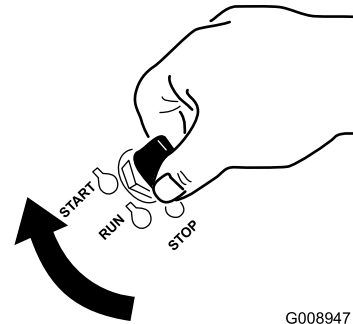

Figure 19

1. Off
2. Run
3. Start

Stopping the Engine

⚠ CAUTION

Children or bystanders may be injured if they move or attempt to operate the tractor while it is unattended.

Always remove the ignition key and set the parking brake when leaving the machine unattended, even if just for a few minutes.

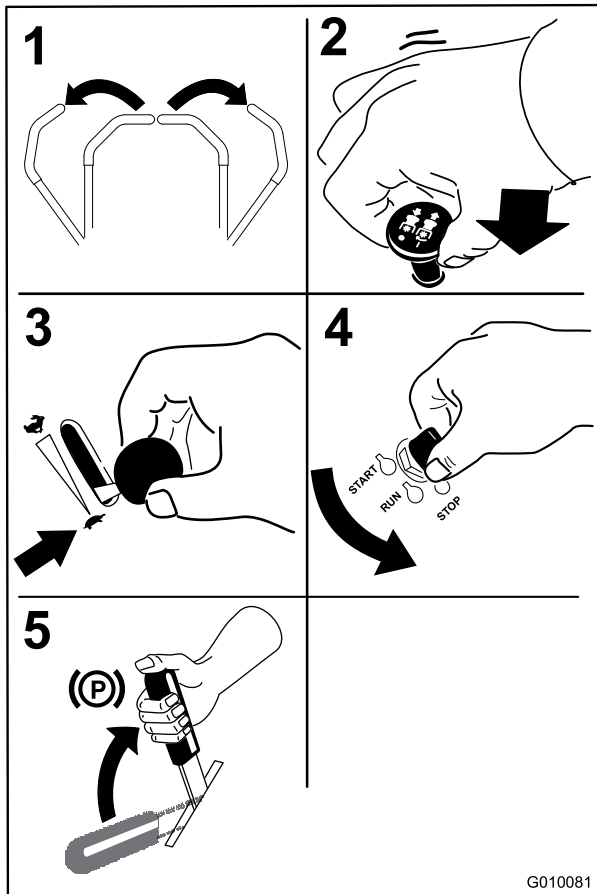

Figure 20

Operating the Mower Blade Control Switch (PTO)

The blade control switch (PTO) starts and stops the mower blades and any powered attachments.

Engaging the Blade Control Switch (PTO)

Engage the blade control switch (PTO) with the throttle position at Fast.

Note: Engaging the blade control switch (PTO) with the throttle position at half or less will cause excessive wear to the drive belts.

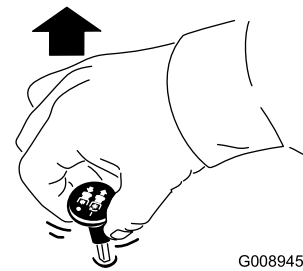

Figure 21

Disengaging the Blade Control Switch (PTO)

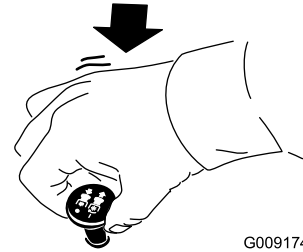

Figure 22

The Safety Interlock System

⚠ WARNING

If safety interlock switches are disconnected or damaged the machine could operate unexpectedly causing personal injury.

- Do not tamper with the interlock switches.
- Check the operation of the interlock switches daily and replace any damaged switches before operating the machine.

Understanding the Safety Interlock System

The safety interlock system is designed to prevent the engine from starting unless:

- The parking brake is engaged.
- The blades are disengaged.
- The motion control levers are in the neutral lock position.

The safety interlock system also is designed to stop the engine when the control levers are out of the neutral lock position with the parking brake on or if you rise from the seat when the blades are engaged.

Testing the Safety Interlock System

Test the safety interlock system before you use the machine each time. If the safety system does not operate as described below, have an Authorized Service Dealer repair the safety system immediately.

1. While sitting on the seat, engage the parking brake and move the blade control switch to On. Try starting the engine; the engine should not crank.
2. While sitting on the seat, engage the parking brake and move the blade control switch to Off. Move either motion control lever (forward or reverse). Try starting the engine; the engine should not crank. Repeat with the other motion control lever.
3. While sitting on the seat, engage the parking brake, move the blade control switch to Off, and lock the motion control levers in neutral. Start the engine. While the engine is running, release the parking brake, engage the blade control switch, and rise slightly from the seat; the engine should stop.
4. While sitting on the seat, engage the parking brake, move the blade control switch to Off, and lock the motion control levers in neutral. Start the engine. While the engine is running, center the motion controls; the engine should stop.

Driving Forward or Backward

The throttle control regulates the engine speed as measured in rpm (revolutions per minute). Place the throttle control in the fast position for best performance. Always operate in the full throttle position when mowing.

⚠ CAUTION

Machine can spin very rapidly. Operator may lose control of machine and cause personal injury or damage to machine.

- Use caution when making turns.
- Slow the machine down before making sharp turns.

Using the Motion Control Levers

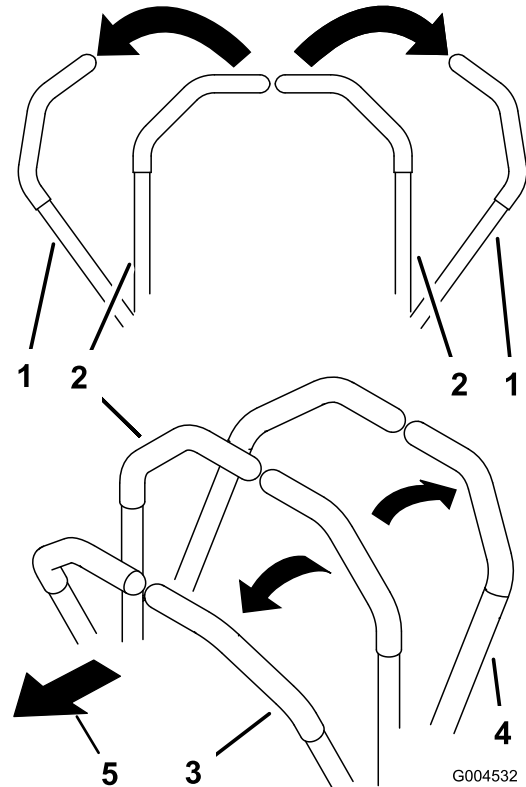

Figure 23

- | | |
|---|-------------|
| 1. Motion control lever-neutral lock position | 3. Forward |
| 2. Center, unlocked position | 4. Backward |

Driving Forward

Note: The engine will kill if the traction control levers are moved with the parking brake engaged.

1. Release the parking brake; refer to Releasing the Parking Brake in Operation.
2. Move the levers to the center, unlocked position.
3. To go forward, slowly push the motion control levers forward (Figure 24).

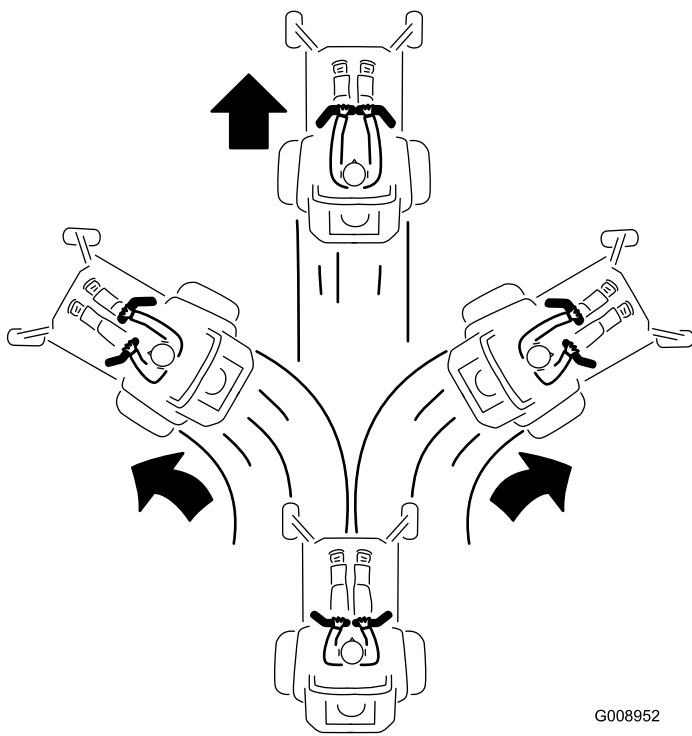

Figure 24

G008952

Driving Backward

1. Move the levers to the center, unlocked position.
2. To go backward, slowly pull the motion control levers rearward (Figure 25).

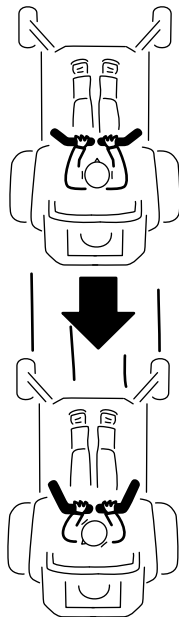

Figure 25

G008953

Stopping the Machine

To stop the machine, move the traction control levers to neutral and move to locked position, disengage the

blade control switch (PTO), and turn the ignition key to off.

Set the parking brake when you leave the machine; refer to Setting the Parking Brake. Remember to remove the key from the ignition switch.

⚠ CAUTION

Children or bystanders may be injured if they move or attempt to operate the tractor while it is unattended.

Always remove the ignition key and set the parking brake when leaving the machine unattended, even if just for a few minutes.

Adjusting the Height of Cut

The machine is equipped with a foot pedal deck lift system. The operator can use the foot pedal to lift the deck briefly to avoid obstacles or lock the deck in the highest height-of-cut or transport position. The operator can use the height of cut lever with the foot pedal to lock the deck in a specific cutting height.

Using the Foot Pedal Deck Lift System

Press the pedal down to raise the deck; continue to press the pedal until the deck is locked in the transport position Figure 26. Push on the deck lift pedal with your foot and raise the height-of-cut lever slightly to disengage the transport lock.

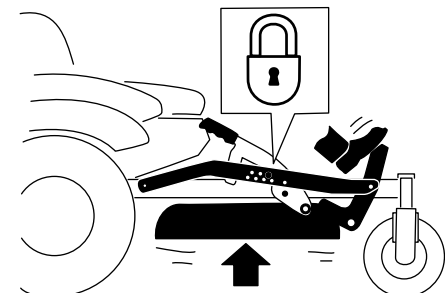
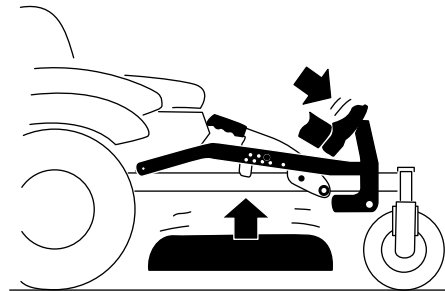

G010219

Figure 26

Transport Lock Position

Adjusting the Height-of-Cut

The height-of-cut can be adjusted from 1-1/2 to 4-1/2 inch (38 to 114 mm) in 1/4 inch (6 mm) increments by relocating the height-of-cut pin into different hole locations.

1. Push on the deck lift pedal with your foot and raise the mower deck to the transport position (also the 4-1/2 inch (114 mm) cutting height position) (Figure 27).
2. To adjust, remove the pin from the height-of-cut bracket (Figure 27).
3. Select a hole in the height-of-cut system corresponding to the height-of-cut desired and, insert the pin (Figure 27).
4. Push on the deck lift pedal with your foot and raise the height-of-cut lever slightly to disengage the transport lock. Lower the deck slowly until the pin makes contact with the lever.

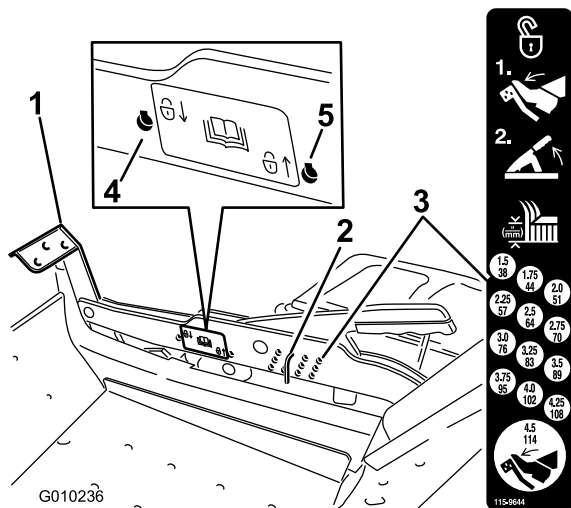

Figure 27

1. Deck lift pedal
2. Cut height pin
3. Height-of-cut positions
4. Lock position. lowest height-of-cut (use only for deck removal)
5. Lock position. transport position

Using the Lock Positions

The deck can be locked in the highest height-of-cut or transport position or the lowest height-of-cut position.

To lock the deck in the transport position:

1. Push on the deck lift pedal with your foot and raise the mower deck to the transport position (also the 4.5 inch (114 mm) cutting height position) (Figure 27).

2. Remove the pin from the height-of-cut bracket (Figure 27).
3. Select the lower hole on the lock decal and insert the pin (Figure 27).

To lock the deck in the lowest height-of-cut position:

1. Push on the deck lift pedal with your foot and raise the mower deck to the transport position (also the 4.5 inch (114 mm) cutting height position) (Figure 27).
2. Remove the pin from the height-of-cut bracket (Figure 27).
3. Push on the deck lift pedal with your foot and lower the mower deck to the lowest position.
4. Select the upper hole on the lock decal and insert the pin (Figure 27).

Adjusting the Anti-Scalp Rollers

Whenever you change the height-of-cut, it is recommended to adjust the height of the anti-scalp rollers.

1. Disengage the blade control switch (PTO), move the motion control levers to the neutral lock position and set the parking brake.
2. Stop the engine, remove the key, and wait for all moving parts to stop before leaving the operating position.

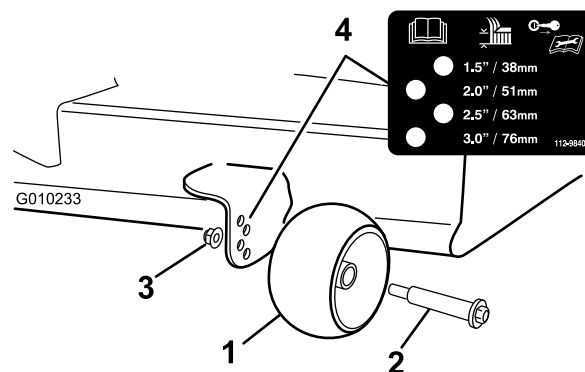

Figure 28

1. Anti-scalp roller
2. Bolt
3. Flange Nut
4. Hole spacing

Positioning the Seat

The seat can move forward and backward. Position the seat where you have the best control of the machine and are most comfortable.

While sitting in the operator's position, raise the seat adjustment lever slightly and move the seat forward or backward to the desired position (Figure 29).

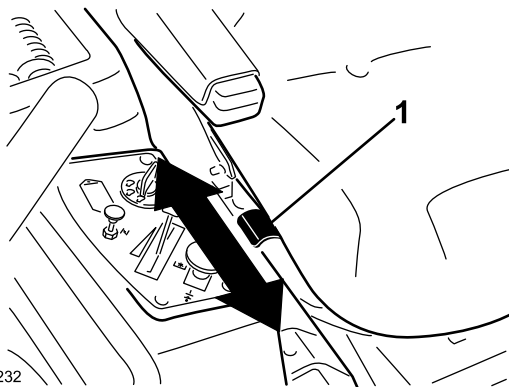

Figure 29

1. Adjustment lever

Adjusting the Motion Control Levers

Adjusting the Height

The motion control levers can be adjusted higher or lower for maximum operator comfort.

1. Remove the 2 bolts and 2 washers holding the control lever to the control arm shaft (Figure 30).
2. Move the control lever to the next set of holes. Secure the lever with the 2 bolts and 2 washers (Figure 30).

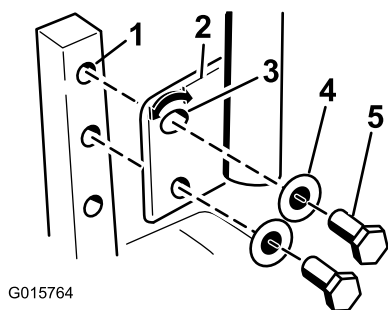

Figure 30

1. Control arm shaft
2. Control lever
3. Slotted, upper hole
4. Washer
5. Bolt

3. Repeat the adjustment for the opposite control lever.

Adjusting the Tilt

The motion control levers can be tilted fore or aft for maximum operator comfort.

1. Loosen the upper bolt holding the control lever to the control arm shaft.
2. Loosen the lower bolt just enough to pivot the control lever fore or aft. Tighten both bolts to secure the control in the new position.
3. Repeat the adjustment for the opposite control lever.

Pushing the Machine by Hand

Important: Always push the machine by hand. Never tow the machine because damage may occur.

To Push the Machine

1. Park the machine on a level surface and disengage the blade control switch.
2. Move the motion control levers outward to neutral lock position, stop the engine, remove the key, and wait for all moving parts to stop before leaving the operating position. Make sure the parking brake is disengaged.
3. Locate the bypass levers at the rear of the machine, on the left and right side of the frame.
4. Move the bypass levers rearward and then down to lock them in place as shown in Figure 31 to disengage the wheel motors. Repeat this on each side of the machine.

The machine is now able to be pushed by hand.



Figure 31

To Operate the Machine

Move the bypass to the position for operating the machine (Figure 31) to engage the wheel motors.

Converting the 48 inch Mower to Side Discharge

The mower deck and mower blades shipped with this machine were designed for optimum mulching performance. Side discharge performance can be improved by replacing the mulching blades with standard cutting blades obtained from your local authorized Toro dealer. To maintain optimum mulching performance, always install the mulching blades that are shipped with this unit when changing back to mulching operation.

Install the fasteners into the same holes in the deck they were originally removed from. This ensure no holes are left open when the deck is operated.

⚠ DANGER

Open holes in the mower expose you and others to thrown debris. Debris thrown out of holes in the mower can cause injury.

- Never operate the mower without hardware mounted in all holes in the mower.
- Install hardware in mounting holes when the baffle is removed.

Removing the Mulch Baffle

1. Park the machine on a level surface and disengage the blade control switch.
2. Move the motion control levers outward to the neutral lock position, set the parking brake, stop the engine, remove the key, and wait for all moving parts to stop before leaving the operating position.
3. Remove the mower as described in the Removing the Mower procedure in the *Maintenance* section for more information.
4. Turn the mower upside down.
5. Remove the existing mower blades installed on your deck. Refer to the Removing the Blades procedure in the *Maintenance* section for more information.
6. Remove the two locknuts (5/16 inch) secured to the welded posts of the left baffle on the top of the mower deck at the center and left of center positions (Figure 32). Remove the carriage bolt and locknut on the side wall of the mower deck securing the left baffle to the deck.

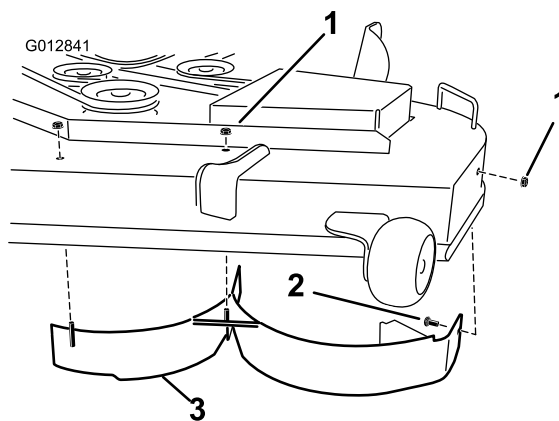

Figure 32

1. Locknut (5/16 inch)
2. Carriage bolt (5/16 x 3/4 inch)
3. Left baffle

7. Remove the left baffle from the mower deck as shown in Figure 32.
8. Remove the carriage bolt (5/16 x 3/4 inch) and locknut (5/16 inch) on the rear wall of the mower deck securing the baffle to the deck (Figure 33).

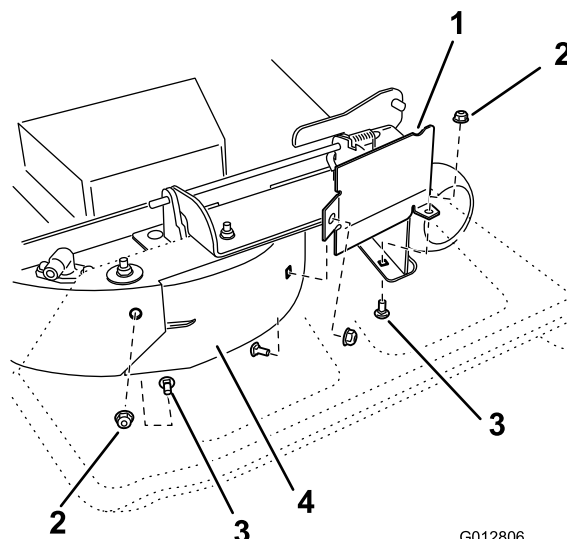

Figure 33

1. Baffle guard
2. Locknut (5/16 inch)
3. Carriage bolt (5/16 x 3/4 inch)
4. Right baffle

9. Locate the baffle guard at the front edge of the side discharge opening. Remove the fasteners securing the baffle guard and the right baffle to the mower deck as shown in Figure 33. Remove the baffle guard and retain all fasteners.
10. Remove the two locknuts (5/16 inch) to securing the welded posts of the right baffle to the top of the mower deck at center and right of center positions

(Figure 34). Remove the right baffle from the mower deck.

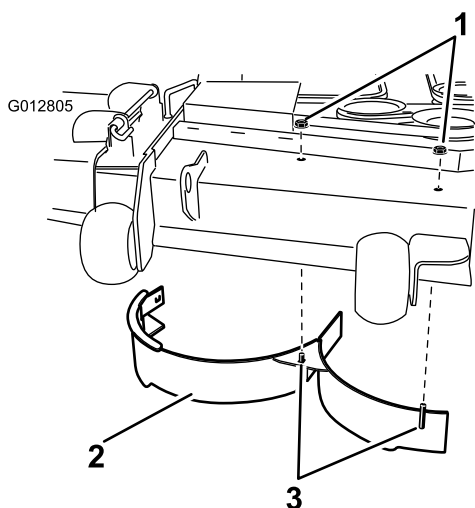

Figure 34

- | | |
|------------------------|-------------------------------|
| 1. Locknut (5/16 inch) | 3. Welded posts, right baffle |
| 2. Right baffle | |

-
11. Locate the cut off baffle in the loose parts bag. Remove the fasteners at the rear holes of the discharge plate. Install the baffle at the side discharge opening on the mower deck (Figure 35).

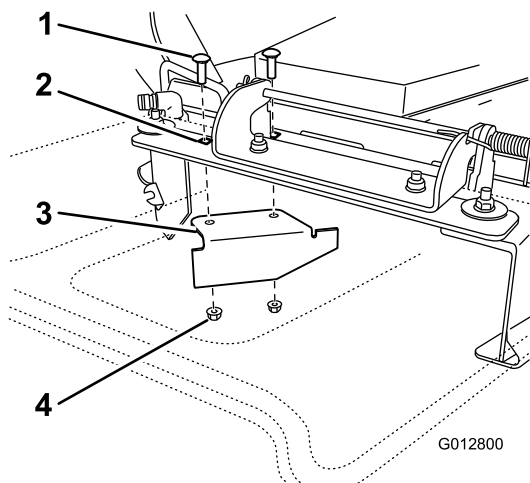

Figure 35

- | | |
|--------------------------------------|----------------------------------|
| 1. Carriage bolt, existing | 3. Cut off baffle, shipped loose |
| 2. Rear holes in the discharge plate | 4. Locknut, existing |

-
12. Use the fasteners removed to secure the cut off baffle to the deck.
13. Install the blades to the deck. Refer to the Installing the Blades procedure in the *Maintenance* section for more information.

Note: Standard cutting blades will improve discharge performance and can be obtained from your local authorized Toro dealer.

14. Install the mower as described in the Installing the Mower procedure in the *Maintenance* section for more information.

Converting the 54 inch Mower to Side Discharge

The mower deck and mower blades shipped with this machine were designed for optimum mulching performance. Side discharge performance can be improved by replacing the mulching blades with standard cutting blades obtained from your local authorized Toro dealer. To maintain optimum mulching performance, always install the mulching blades that are shipped with this unit when changing back to mulching operation.

Install the fasteners into the same holes in the deck they were originally removed from. This ensures no holes are left open when the deck is operated.

⚠ DANGER

Open holes in the mower expose you and others to thrown debris. Debris thrown out of holes in the mower can cause injury.

- Never operate the mower without hardware mounted in all holes in the mower.
- Install hardware in mounting holes when the baffle is removed.

Removing the Mulch Baffle

1. Park the machine on a level surface and disengage the blade control switch.
2. Move the motion control levers outward to the neutral lock position, set the parking brake, stop the engine, remove the key, and wait for all moving parts to stop before leaving the operating position.
3. Remove the mower as described in the Removing the Mower procedure in the *Maintenance* section for more information.
4. Turn the mower upside down.
5. Remove the existing mower blades installed on your deck. Refer to the Removing the Blades procedure in the *Maintenance* section for more information.
6. Remove the three locknuts (5/16 inch) secured to the welded posts of the left baffle on the top of the mower deck at the center, left of center and left positions (Figure 36). Remove the carriage bolt and

locknut on the side wall of the mower deck securing the left baffle to the deck.

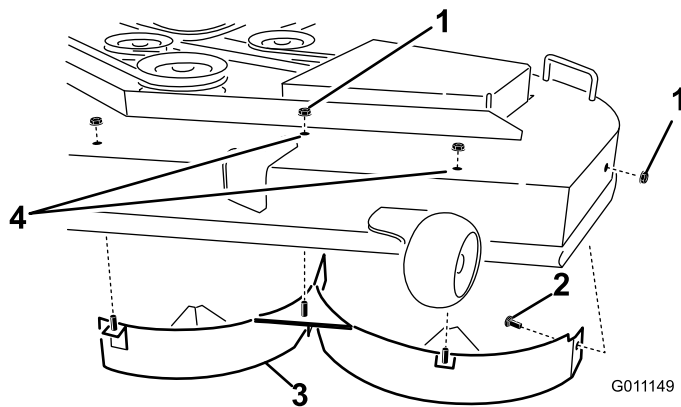

Figure 36

- | | |
|------------------------------------|---------------------------|
| 1. Locknut (5/16 inch) | 3. Left baffle |
| 2. Carriage bolt (5/16 x 3/4 inch) | 4. Install fasteners here |

7. Remove the left baffle from the mower deck as shown in Figure 36.
8. Locate the two bolts in loose parts and use the existing locknuts. Install these fasteners into the holes shown in Figure 36 on the mower deck to prevent flying debris. Install the bolt up, through the underside of the deck and use an existing locknut to secure from the topside.

⚠ WARNING

Open holes in the mower expose you and others to thrown debris which can cause severe injury.

- **Never operate the mower without hardware mounted in all holes in the mower housing.**
- **Install the hardware in the mounting holes when you remove the mulching baffle.**

9. Remove the carriage bolt (5/16 x 3/4 inch) and locknut (5/16 inch) on the rear wall of the mower deck securing the baffle to the deck (Figure 37).

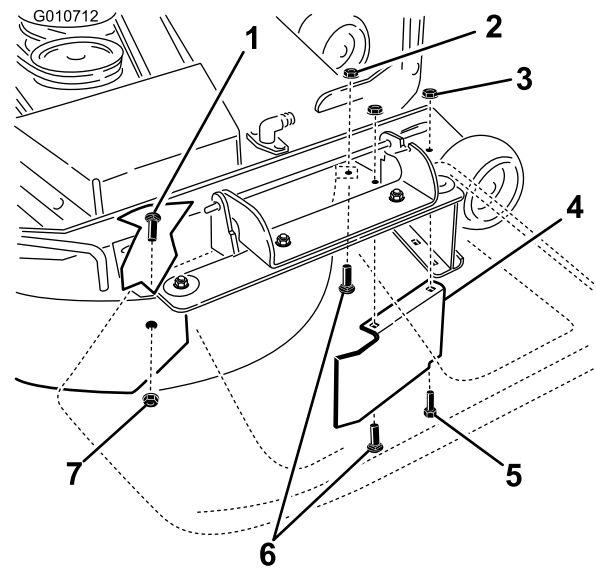

Figure 37

- | | |
|---|---|
| 1. Carriage bolt (5/16 x 3/4 inch) | 5. Hex head bolt, forward hole in deck (reinstall after baffle is removed) |
| 2. Locknuts, front of discharge plate (reinstall after baffle is removed) | 6. Carriage bolts, front of discharge plate (reinstall after baffle is removed) |
| 3. Locknut, forward hole in deck (reinstall after baffle is removed) | 7. Locknut (5/16 inch) |
| 4. Baffle guard, 54 inch decks | |

10. Locate the baffle guard at the front edge of the side discharge opening. Remove the fasteners securing the baffle guard and the right baffle to the mower deck as shown in Figure 37. Remove the baffle guard and retain all fasteners.
11. Remove the two locknuts (5/16 inch) securing the welded posts of the right baffle to the top of the mower deck at center and right of center positions (Figure 38).
12. Remove the carriage bolt and locknut securing the right baffle to the top of the mower deck. Remove the right baffle from the mower deck (Figure 38).

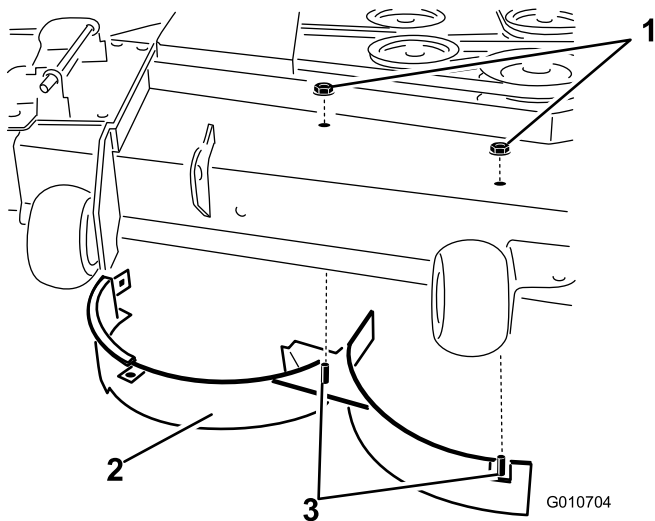

Figure 38

- | | |
|------------------------|-------------------------------|
| 1. Locknut (5/16 inch) | 3. Welded posts, right baffle |
| 2. Right baffle | 4. Carriage bolt |

13. Install the fasteners removed previously at the front holes in the discharge plate and forward hole in the deck (Figure 37).
14. Locate the cut off baffle in the loose parts bag. Remove the fasteners at the rear holes of the discharge plate. Install the baffle at the side discharge opening on the mower deck (Figure 39).

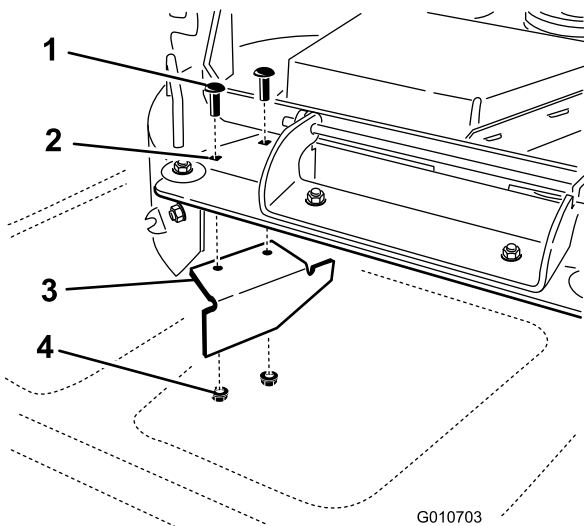

Figure 39

- | | |
|--------------------------------------|-------------------|
| 1. Carriage bolt | 3. Cut off baffle |
| 2. Rear holes in the discharge plate | 4. Locknut |

15. Use the fasteners removed to secure the cut off baffle to the deck.
16. Install the blades to the deck. Refer to the Installing the Blades procedure in the *Maintenance* section for more information.

Note: Standard cutting blades will improve discharge performance and can be obtained from your local authorized Toro dealer.

17. Install the mower as described in the Installing the Mower procedure in the *Maintenance* section for more information.

Using the Side Discharge

The mower has a hinged grass deflector that disperses clippings to the side and down toward the turf.

⚠ DANGER

Without a grass deflector, discharge cover, or complete grass catcher assembly mounted in place, you and others are exposed to blade contact and thrown debris. Contact with rotating mower blade(s) and thrown debris will cause injury or death.

- Never remove the grass deflector from the mower because the grass deflector routes material down toward the turf. If the grass deflector is ever damaged, replace it immediately.
- Never put your hands or feet under the mower.
- Never try to clear the discharge area or mower blades unless you move the blade control switch (PTO) to the off position, rotate the ignition key to off and remove the key.
- Make sure the grass deflector is in the down position.

Operating Tips

Fast Throttle Setting

For best mowing and maximum air circulation, operate the engine at the fast throttle position. Air is required to thoroughly cut grass clippings, so do not set the height-of-cut so low as to totally surround the mower by uncut grass. Always try to have one side of the mower free from uncut grass, which allows air to be drawn into the mower.

Cutting a Lawn for the First Time

Cut grass slightly longer than normal to ensure the cutting height of the mower does not scalp any uneven ground. However, the cutting height used in the past is generally the best one to use. When cutting grass longer

than six inches tall, you may want to cut the lawn twice to ensure an acceptable quality of cut.

Cut 1/3 of the Grass Blade

It is best to cut only about 1/3 of the grass blade. Cutting more than that is not recommended unless grass is sparse, or it is late fall when grass grows more slowly.

Mowing Direction

Alternate mowing direction to keep the grass standing straight. This also helps disperse clippings which enhances decomposition and fertilization.

Mow at Correct Intervals

Normally, mow every four days. But remember, grass grows at different rates at different times. So to maintain the same cutting height, which is a good practice, mow more often in early spring. As the grass growth rate slows in mid summer, mow less frequently. If you cannot mow for an extended period, first mow at a high cutting height; then mow again two days later at a lower height setting.

Cutting Speed

To improve cut quality, use a slower ground speed in certain conditions.

Avoid Cutting Too Low

If the cutting width of the mower is wider than the mower you previously used, raise the cutting height to ensure that uneven turf is not cut too short.

Long Grass

If the grass is ever allowed to grow slightly longer than normal, or if it contains a high degree of moisture, raise the cutting height higher than usual and cut the grass at this setting. Then cut the grass again using the lower, normal setting.

When Stopping

If the machine's forward motion must be stopped while mowing, a clump of grass clippings may drop onto your lawn. To avoid this, move onto a previously cut area with the blades engaged.

Keep the Underside of the Mower Clean

Clean clippings and dirt from the underside of the mower after each use. If grass and dirt build up inside the mower, cutting quality will eventually become unsatisfactory.

Blade Maintenance

Maintain a sharp blade throughout the cutting season because a sharp blade cuts cleanly without tearing or shredding the grass blades. Tearing and shredding turns grass brown at the edges, which slows growth and increases the chance of disease. Check the cutter blades daily for sharpness, and for any wear or damage. File down any nicks and sharpen the blades as necessary. If a blade is damaged or worn, replace it immediately with a genuine TORO replacement blade.

Maintenance

Recommended Maintenance Schedule(s)

| Maintenance Service Interval | Maintenance Procedure |
|------------------------------|---|
| After the first 8 hours | <ul style="list-style-type: none">• Change the engine oil. |
| After the first 50 hours | <ul style="list-style-type: none">• Change the hydraulic system filter and oil. |
| Before each use or daily | <ul style="list-style-type: none">• Check the safety interlock system.• Check the engine oil level.• Clean the air intake screen.• Check the mower blades.• Inspect the grass deflector for damage• Clean the mower housing. |
| Every 25 hours | <ul style="list-style-type: none">• Grease all lubrication points.• Check tire pressure.• Check the hydraulic oil level in the expansion tank. |
| Every 50 hours | <ul style="list-style-type: none">• Inspect the belts for cracks and wear. |
| Every 100 hours | <ul style="list-style-type: none">• Service the paper element (more often in dusty, dirty conditions).• Change the engine oil (more often in dusty, dirty conditions).• Check the spark plug(s).• Replace the fuel filters (more often under dusty, dirty conditions).• Inspect the emissions filter. |
| Every 200 hours | <ul style="list-style-type: none">• Replace the paper element (more often in dusty, dirty conditions).• Change the oil filter. (more often in dusty, dirty conditions) |
| Every 400 hours | <ul style="list-style-type: none">• Change the hydraulic system filter and oil. |
| Monthly | <ul style="list-style-type: none">• Check the battery charge. |
| Yearly or before storage | <ul style="list-style-type: none">• Paint chipped surfaces.• Check all maintenance procedures listed above before storage. |

Important: Refer to your engine operator's manual for additional maintenance procedures.

▲ CAUTION

If you leave the key in the ignition switch, someone could accidentally start the engine and seriously injure you or other bystanders.

Remove the key from the ignition and disconnect the wire from the spark plug before you do any maintenance. Set the wire aside so that it does not accidentally contact the spark plug.

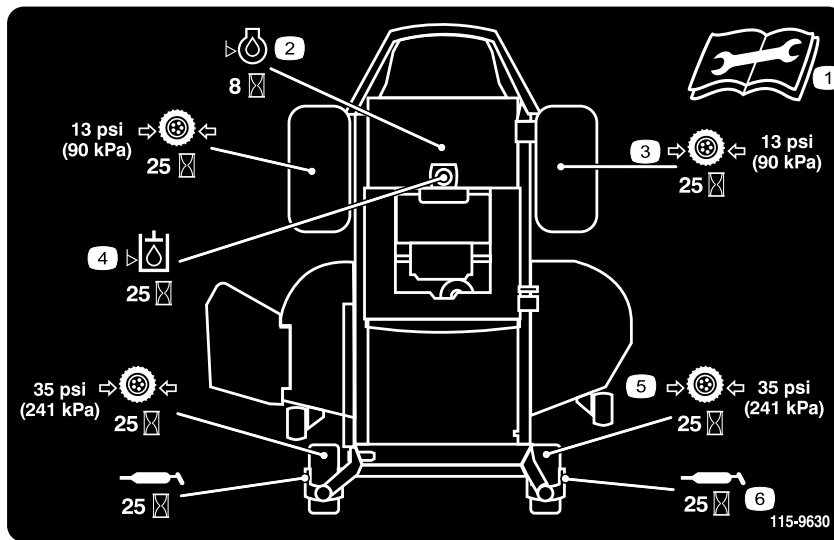

Figure 40

Located on the seat pan underside

1. Read the *Operator's Manual* before performing any maintenance.
2. Check the engine oil every 8 hours
3. Check the drive wheel tire pressure every 25 hours
4. Check the hydraulic oil every 25 hours
5. Check the caster wheel tire pressure every 25 hours
6. Lubricate the caster wheel every 25 hours

Premaintenance Procedures

Raising the Seat

Make sure the motion control levers are locked in the neutral lock position. Lift the seat forward.

The following components can be accessed by raising the seat:

- Service decal
- Fuses
- Battery and cables

Lubrication

Greasing the Bearings

Service Interval: Every 25 hours—Grease all lubrication points.

Grease Type: No. 2 General Purpose Lithium Base Grease

1. Park the machine on a level surface and disengage the blade control switch.
2. Move the motion control levers outward to the neutral lock position, stop the engine, remove the key, and wait for all moving parts to stop before leaving the operating position.
3. Clean the grease fittings (Figure 41 and Figure 40) with a rag. Make sure to scrape any paint off of the front of the fitting(s).

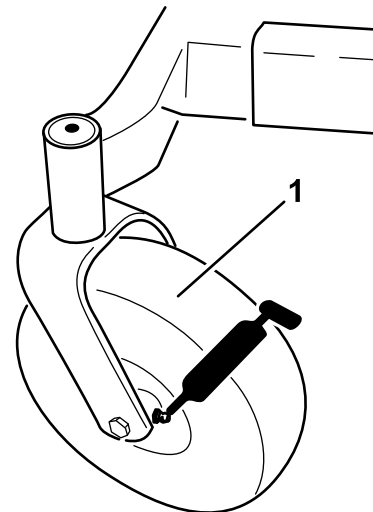

G009949

Figure 41

1. Front caster tire

-
4. Connect a grease gun to each fitting (Figure 40 and Figure 41). Pump grease into the fittings until grease begins to ooze out of the bearings.
 5. Wipe up any excess grease.

Engine Maintenance

⚠ WARNING

Contact with hot surfaces may cause personal injury.

Keep hands, feet, face, clothing and other body parts away the muffler and other hot surfaces.

Servicing the Air Cleaner

Note: Service the air cleaner more frequently (every few hours) if operating conditions are extremely dusty or sandy.

Removing the Element

1. Park the machine on a level surface and disengage the blade control (PTO).
2. Move the motion control levers to the neutral lock position, set the parking brake, stop the engine, remove the key, and wait for all moving parts to stop before leaving the operating position.
3. Clean around the air cleaner cover to prevent dirt from getting into the engine and causing damage. Lift the cover and remove the hose clamp securing the air cleaner assembly to the engine (Figure 42).
4. Loosen the hose clamp and remove the paper element (Figure 42).

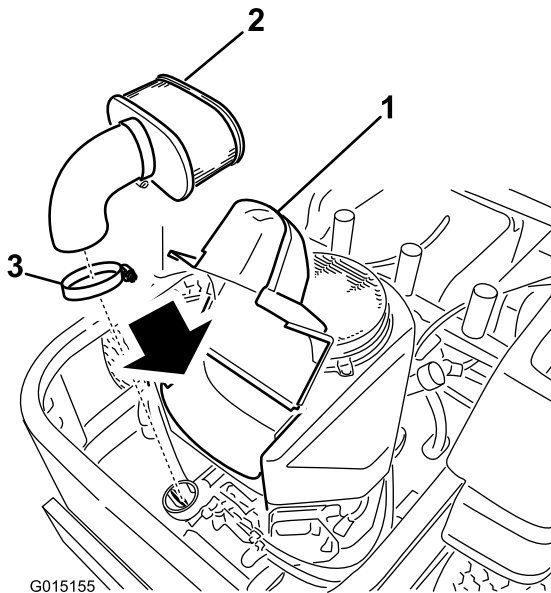

Figure 42

1. Cover
2. Paper element
3. Hose clamp

Cleaning the Element

Service Interval: Every 100 hours—Service the paper element (more often in dusty, dirty conditions).

Every 200 hours/Yearly (whichever comes first)—Replace the paper element (more often in dusty, dirty conditions).

1. Lightly tap the element on a flat surface to remove dust and dirt.
2. Inspect the element for tears, an oily film, and damage to the seal.

Important: Never clean the paper element with pressurized air or liquids, such as solvent, gas, or kerosene. Replace the paper element if it is damaged or cannot be cleaned thoroughly.

Servicing the Engine Oil

Oil Type: Detergent oil (API service SF, SG, SH, SJ, or SL)

Crankcase Capacity: 1.9 qt (1.8 l), [when oil filter is removed: 2.2 qt (2.1 l)]

Viscosity: See the table below.

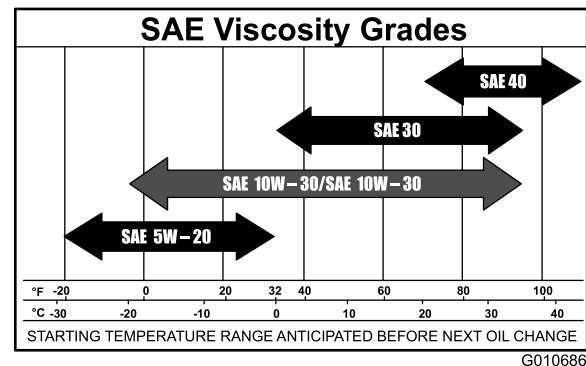

Figure 43

Note: Using multi grade oils (5W-20, 10W-30, and 10W-40) will increase oil consumption. Check oil level more frequently when using them.

Checking the Engine Oil Level

Service Interval: Before each use or daily

Note: Check the oil when the engine is cold.

⚠ WARNING

Contact with hot surfaces may cause personal injury.

Keep hands, feet, face, clothing and other body parts away the muffler and other hot surfaces.

Important: Do not overfill the crankcase with oil because damage to the engine may result. Do not run engine with oil below the low mark because the engine may be damaged.

1. Park the machine on a level surface, disengage the blade control switch, stop the engine, engage parking brake, and remove the key.
2. Make sure the engine is stopped, level, and is cool so the oil has had time to drain into the sump.
3. To keep dirt, grass clippings, etc., out of the engine, clean the area around the oil fill cap/dipstick before removing it.
4. Stop the engine, remove the key, and wait for all moving parts to stop before leaving the operating position (Figure 44).

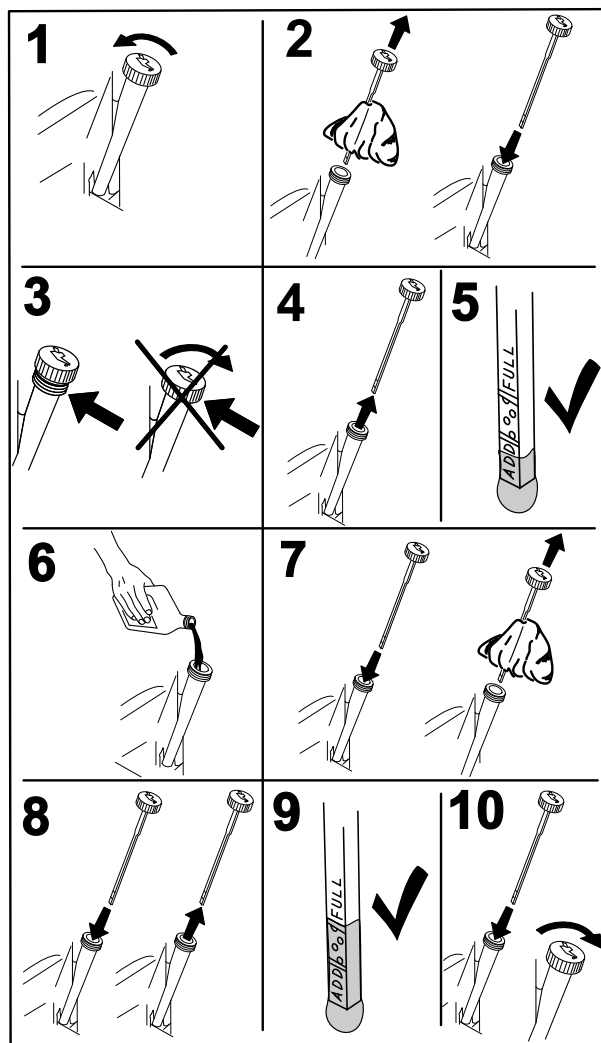

Figure 44

G008792

Changing the Engine Oil

Service Interval: After the first 8 hours—Change the engine oil.

Every 100 hours—Change the engine oil (more often in dusty, dirty conditions).

Note: Dispose of the used oil at a recycling center.

1. Start the engine and let it run five minutes. This warms the oil so it drains better.
2. Park the machine so that the drain side is slightly lower than the opposite side to ensure the oil drains completely.
3. Disengage the PTO, move the motion control levers to the neutral locked position and set the parking brake.
4. Stop the engine, remove the key, and wait for all moving parts to stop before leaving the operating position (Figure 45).

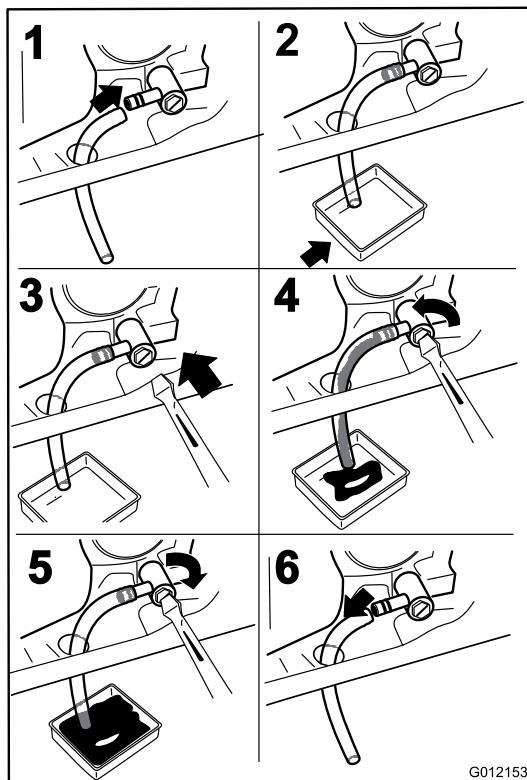

Figure 45

Changing the Engine Oil Filter

Service Interval: Every 200 hours—Change the oil filter. (more often in dusty, dirty conditions)

Note: Change the engine oil filter more frequently when operating conditions are extremely dusty or sandy.

1. Drain the oil from the engine; refer to Changing the Engine Oil.
2. Change the engine oil filter (Figure 47).

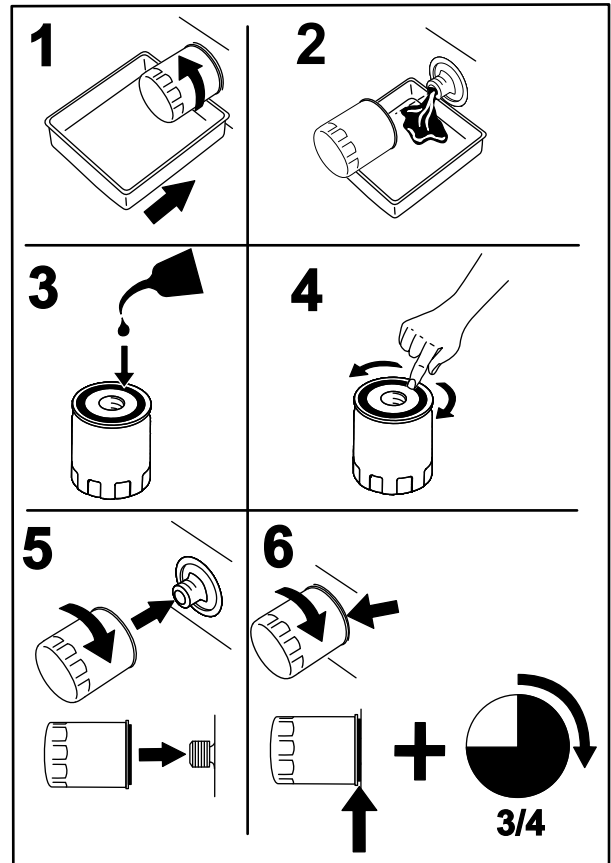

Figure 47

5. Slowly pour approximately 80% of the specified oil into the filler tube and slowly add the additional oil to bring it to the **Full** mark (Figure 46).

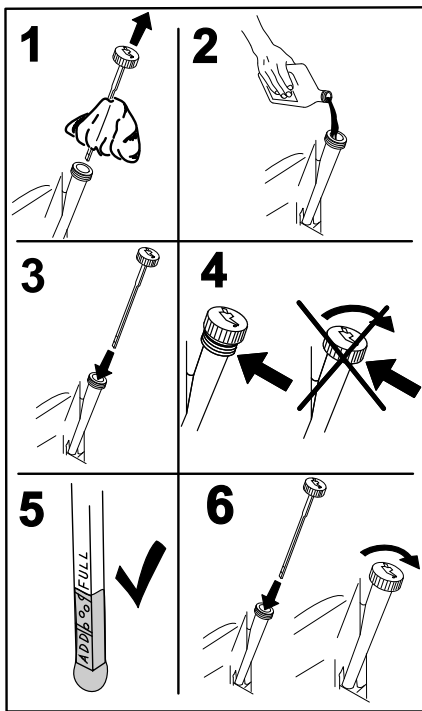

Figure 46

Note: Ensure the oil filter gasket touches the engine and then an extra 3/4 turn is completed.

3. Fill the crankcase with the proper type of new oil; refer to Changing the Oil.

Servicing the Spark Plug

Service Interval: Every 100 hours—Check the spark plug(s).

Make sure the air gap between the center and side electrodes is correct before installing the spark plug. Use a spark plug wrench for removing and installing the spark plug(s) and a gapping tool/feeler gauge to

check and adjust the air gap. Install a new spark plug(s) if necessary.

Type: NGK BPR4ES (or equivalent)

Air Gap: 0.030 inch (0.76 mm)

Removing the Spark Plug

1. Disengage the PTO, move the motion control levers to the neutral locked position and set the parking brake.
2. Stop the engine, remove the key, and wait for all moving parts to stop before leaving the operating position.

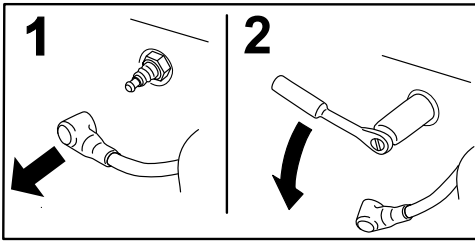

G008791

Figure 48

Note: Due to the deep recess around the spark plug, blowing out the cavity with compressed air is usually the most effective method for cleaning. The spark plug is most accessible when the blower housing is removed for cleaning.

Checking the Spark Plug

Important: Never clean the spark plug(s). Always replace the spark plug(s) when it has: a black coating, worn electrodes, an oily film, or cracks.

If you see light brown or gray on the insulator, the engine is operating properly. A black coating on the insulator usually means the air cleaner is dirty.

Set the gap to 0.030 inches (0.76 mm).

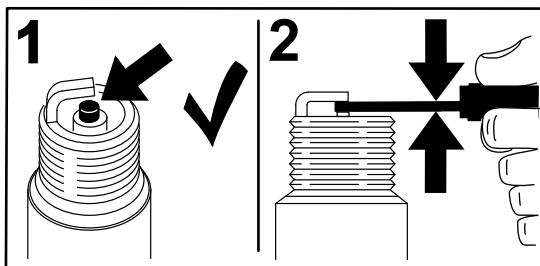

G008794

Figure 49

Installing the Spark Plug

Tighten the spark plug(s) to 16 ft-lb (22 N-m).

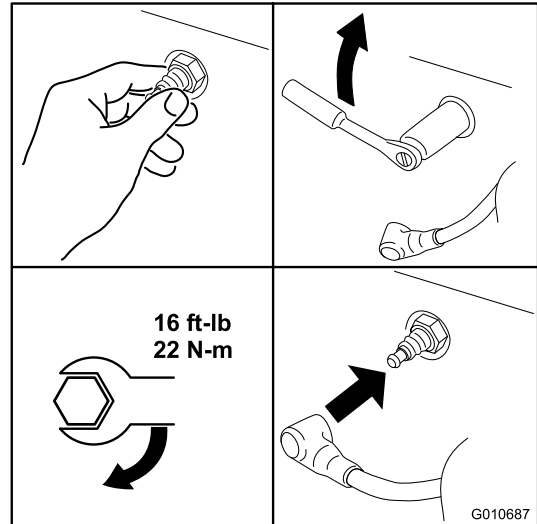

Figure 50

Cleaning the Cooling System

Clean the air intake screen from grass and debris before each use.

1. Disengage the blade control switch and move the control levers to the neutral locked position and apply the parking brake.
2. Stop the engine, remove the key, and wait for all moving parts to stop before leaving the operating position.
3. Remove the air intake screen, air cleaner cover, and fan housing.
4. Clean debris and grass from the parts.
5. Install the air intake screen, air cleaner cover, and fan housing.

Fuel System Maintenance

Replacing the Fuel Filter

Service Interval: Every 100 hours/Yearly (whichever comes first) (more often under dusty, dirty conditions).

1. Disengage the blade control switch (PTO), move the motion control levers to the neutral lock position, and set the parking brake.
2. Stop the engine, remove the key, and wait for all moving parts to stop before leaving the operating position.
3. Allow the machine to cool down.
4. Raise the seat and locate the fuel filters as shown in Figure 51.

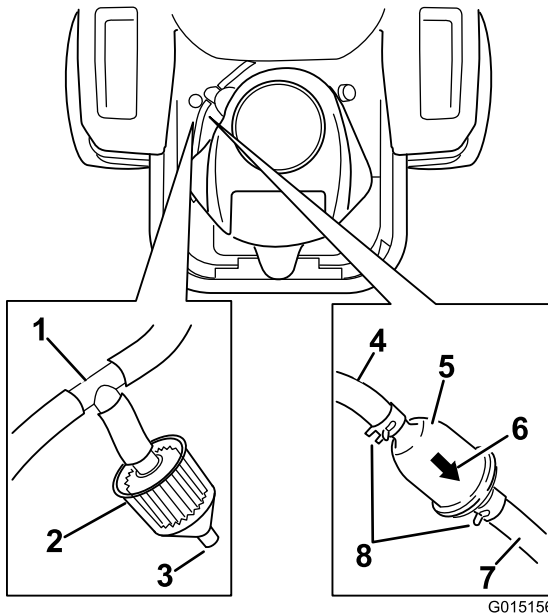

Figure 51

- | | |
|---------------------------|-------------------------|
| 1. Tee Fitting, vent line | 5. In-line Fuel filter |
| 2. Emissions filter | 6. Flow direction arrow |
| 3. Open port | 7. Fuel line to engine |
| 4. Fuel line from tank | 8. Hose clamp |

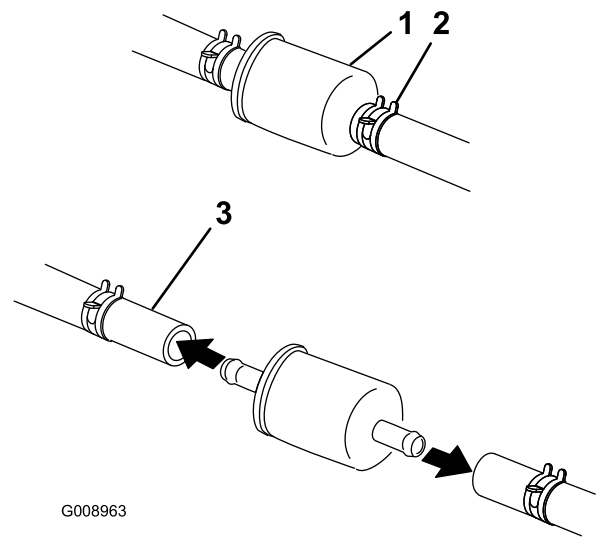

Figure 52

- | | |
|----------------|--------------|
| 1. Fuel filter | 3. Fuel line |
| 2. Hose clamp | |

5. Squeeze the ends of the hose clamps together and slide them away from the filter (Figure 52).
6. Remove the filter from the fuel lines.
7. Install a new filter with the flow direction arrow coming from the fuel tank and pointing to the engine. Move the hose clamps close to the filter (Figure 51) to secure it in place.

Servicing the Emissions Filter

Service Interval: Every 100 hours/Yearly (whichever comes first)

The machine is equipped with a emissions filter (Figure 51) connected to a tee fitting on the vent line coming from the gas tank. The filter has an open port by design. The filter should be inspected regularly. Replace the filter if the filter is dirty or clogged.

5. Squeeze the ends of the hose clamps together and slide them away from the filter (Figure 52).

Electrical System Maintenance

Servicing the Battery

Service Interval: Monthly

WARNING

CALIFORNIA Proposition 65 Warning

Battery posts, terminals, and related accessories contain lead and lead compounds, chemicals known to the State of California to cause cancer and reproductive harm.
Wash hands after handling.

⚠ DANGER

Battery electrolyte contains sulfuric acid which is a deadly poison and causes severe burns.

Do not drink electrolyte and avoid contact with skin, eyes or clothing. Wear safety glasses to shield your eyes and rubber gloves to protect your hands.

Removing the Battery

⚠ WARNING

Battery terminals or metal tools could short against metal machine components causing sparks. Sparks can cause the battery gasses to explode, resulting in personal injury.

- When removing or installing the battery, do not allow the battery terminals to touch any metal parts of the machine.
- Do not allow metal tools to short between the battery terminals and metal parts of the machine.

⚠ WARNING

Incorrect battery cable routing could damage the machine and cables causing sparks. Sparks can cause the battery gasses to explode, resulting in personal injury.

- Always Disconnect the negative (black) battery cable before disconnecting the positive (red) cable.
 - Always Reconnect the positive (red) battery cable before reconnecting the negative (black) cable.
1. Disengage the blade control switch (PTO), move the motion control levers to the neutral lock position and set the parking brake.
 2. Stop the engine, remove the key, and wait for all moving parts to stop before leaving the operating position.
 3. Remove the wing nut securing the battery clamp (Figure 53).

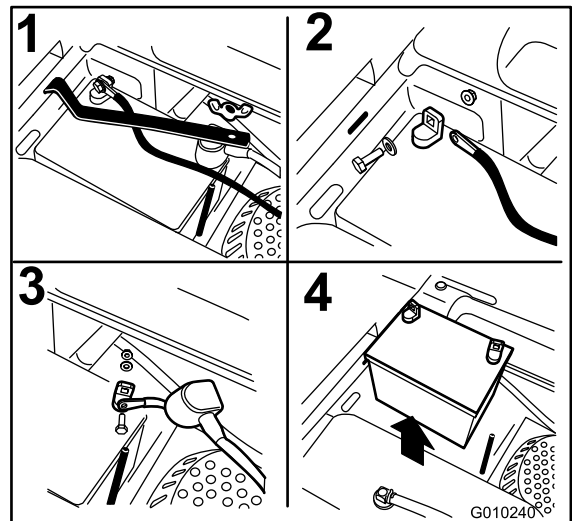

Figure 53

1. Remove the wing nut and
 2. Remove the negative battery cable before the positive
 3. Remove the positive battery cable
 4. Remove battery
-
4. Remove the clamp (Figure 53).
 5. First disconnect the negative battery cable (black) from the negative (-)(black) battery terminal (Figure 53).
 6. Slide the red terminal boot off the positive (red) battery terminal and remove the positive (+)(red) battery cable (Figure 53).
 7. Remove the battery.

Installing the Battery

1. Position battery in the tray with the terminal posts opposite from the fuel tank (Figure 53).
2. First, install the positive (red) battery cable to positive (+) battery terminal.
3. Then install the negative battery cable to the negative (-) battery terminal.
4. Secure the cables with 2 bolts, 2 washers, and 2 locknuts (Figure 53).
5. Slide the red terminal boot onto the positive (red) battery post.
6. Install the clamp and secure it with the wing nut (Figure 53).

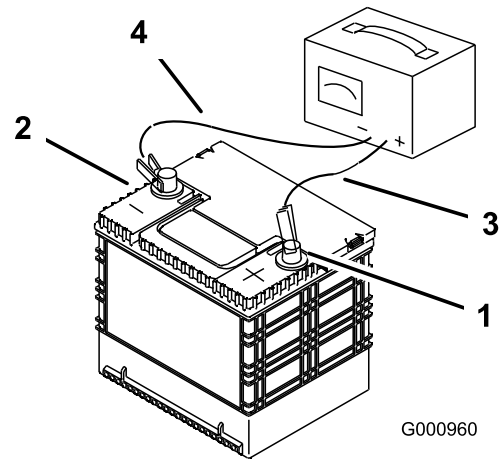

Figure 54

- | | |
|--------------------------|---------------------------|
| 1. Positive Battery Post | 3. Red (+) Charger Lead |
| 2. Negative Battery Post | 4. Black (-) Charger Lead |

Charging the Battery

⚠ WARNING

Charging the battery produces gasses that can explode.

Never smoke near the battery and keep sparks and flames away from battery.

Important: Always keep the battery fully charged. This is especially important to prevent battery damage when the temperature is below 32°F (0°C).

1. Charge battery for 10 to 15 minutes at 25 to 30 amps or 30 minutes at 10 amps.
2. When the battery is fully charged, unplug the charger from the electrical outlet, then disconnect the charger leads from the battery posts (Figure 54).
3. Install the battery in the machine and connect the battery cables, refer to Installing the Battery.

Note: Do not run the machine with the battery disconnected, electrical damage may occur.

Servicing the Fuses

The electrical system is protected by fuses. It requires no maintenance, however, if a fuse blows check the component/circuit for a malfunction or short.

Fuses:

- Main, 30 amp, blade-type
 - Engine, 20 amp, blade-type
1. The fuses are located on right hand console next to the seat (Figure 55).
 2. To replace the fuses, pull out on the fuse to remove it.
 3. Install a new fuse of the same amperage removed (Figure 55).

Drive System Maintenance

Checking the Tire Pressure

Service Interval: Every 25 hours—Check tire pressure.

Maintain the air pressure in the front and rear tires as specified. Uneven tire pressure can cause uneven cut. Check the pressure at the valve stem (Figure 56). Check the tires when they are cold to get the most accurate pressure reading.

Refer to the maximum pressure suggested by the tire manufacturer on the sidewall of the caster wheel tires.

Inflate the rear drive wheel tires to 13 psi (90 kPa).

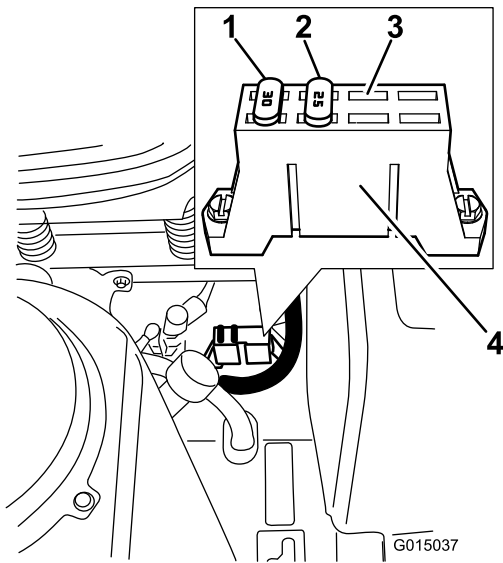

Figure 55

-
- | | |
|-----------|------------------------|
| 1. 30 amp | 3. Open accessory slot |
| 2. 25 amp | 4. Fuse block |

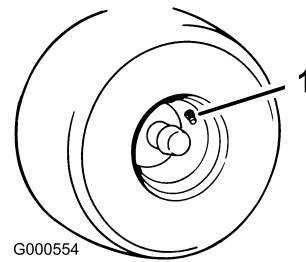

Figure 56

-
- | |
|---------------|
| 1. Valve stem |
|---------------|
-

Hydraulic System Maintenance

Oil Type: 20W-50 engine oil.

Important: Use oil specified or equivalent. Other fluids could cause system damage.

Checking the Hydraulic Oil Level

Service Interval: Every 25 hours

Check expansion reservoir and if necessary add 20W-50 engine oil to the FULL COLD line

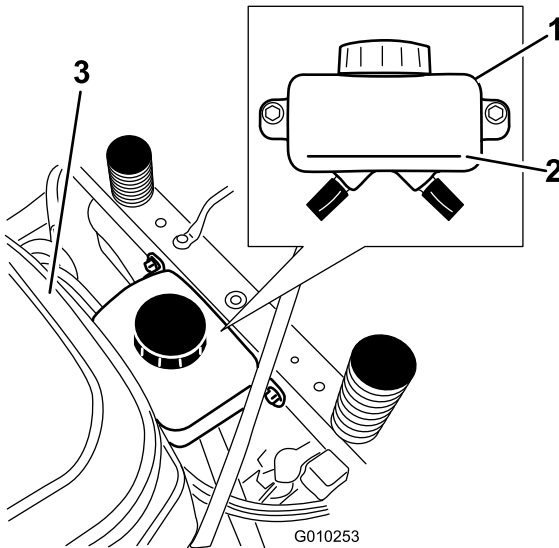

Figure 57

- 1. Expansion reservoir
- 2. Full Cold line
- 3. Engine

Changing the Hydraulic System Filter and Oil

The filter and oil are changed at the same time. **Do Not** reuse oil. Once the new filter is installed and oil is added any air in the system must be purged.

The bleeding process is repeated until the oil remains at the FULL COLD line in the reservoir after purging. **Failure to properly perform this procedure can result in irreparable damage to the transaxle drive system.**

Removing Hydraulic System Filters

1. Stop engine, wait for all moving parts to stop, and allow engine to cool. Remove the key and engage the parking brake.

2. Locate the filter and guards on each transaxle drive system (Figure 58). Remove three screws securing the filter guard and guard.

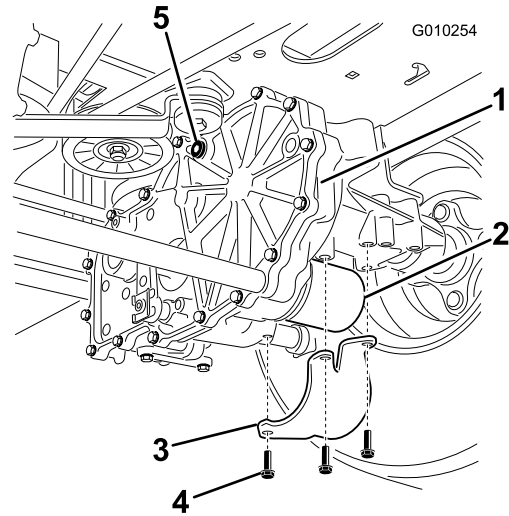

Figure 58

Right side shown

- 1. Transaxle drive
- 2. Oil filter
- 3. Filter guard
- 4. Screws
- 5. Vent plug

3. Carefully clean area around filters. It is important that no dirt or contamination enter hydraulic system.
4. Place a container below the filter to catch the oil that drains when the filter and vent plugs are removed.
5. Locate and remove the vent plug on each transmission
6. Unscrew the filter to remove and allow oil to drain from drive system.

Repeat this procedure for both filters.

Installing the Hydraulic System Filters

Service Interval: After the first 50 hours
Every 400 hours

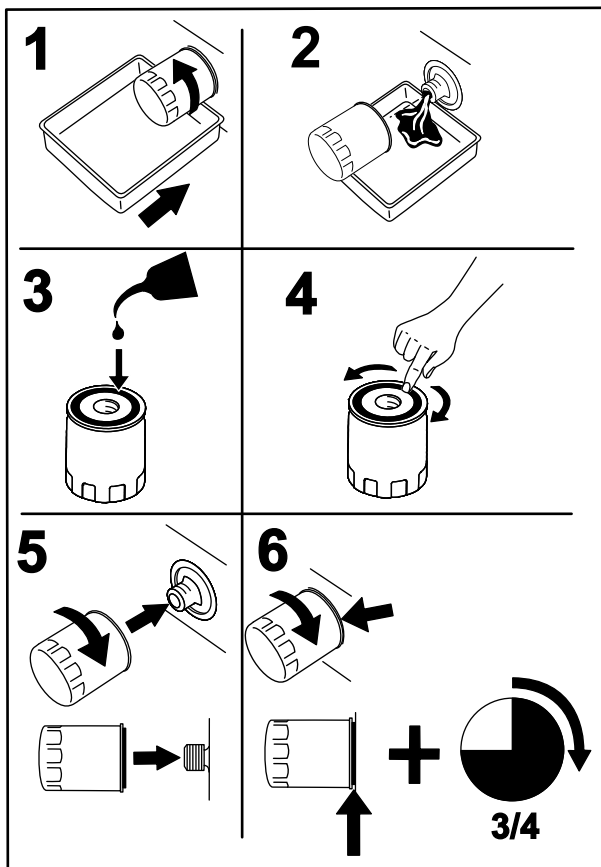

Figure 59

G008748

hydraulic filters and oil can result in irreparable damage to the transaxle drive system.

Bleeding the Hydraulic System

1. Raise the rear of machine up and support with jack stands (or equivalent support) just high enough to allow drive wheels to turn freely.

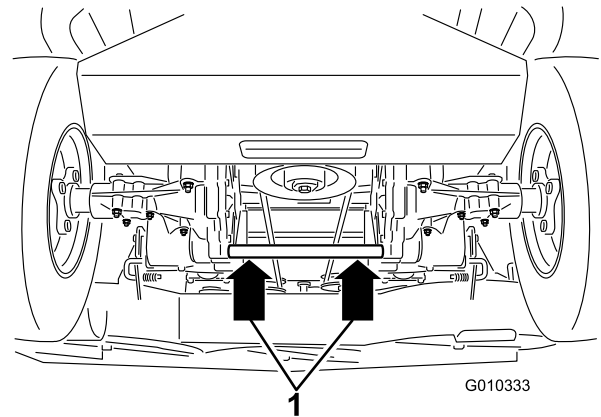

Figure 60

1. Jacking points

2. Enter the operator's position. Start engine and move throttle control ahead to 1/2 throttle position. Disengage parking brake.
 - A. Move the bypass levers into the pushing the machine position; refer to the Pushing the Machine by Hand section in Operation. With the bypass valves open and the engine running, slowly move the motion control levers in both forward and reverse (5 or 6 times).
 - B. Move the bypass levers into the operating the machine position. With the bypass valve closed and the engine running, slowly move the directional control in both forward and reverse directions (5 to 6 times).
 - C. Stop the engine and check the oil level in the expansion reservoir. Add the specified oil as until it reaches the FULL COLD line on the expansion reservoir.
3. Repeat step 2 until all the air is completely purged from the system.

When the transaxle operates at normal noise levels and moves smoothly forward and reverse at normal speeds, then the transaxle is considered purged.

4. Check the oil level in the expansion reservoir one last time. Add the specified oil as until it reaches the FULL COLD line on the expansion reservoir if necessary.

1. Apply a thin coat of oil on the surface of the rubber seal of each filter.
2. Turn the filter clockwise until rubber seal contacts the filter adapter then tighten the filter an additional 3/4 to 1 full turn. Repeat for the other filter
3. Install the filter guards over each filter as previously removed. Use the three screws to secure the filter guards.
4. Verify the vent plugs are removed before adding the oil.
5. Slowly pour the specified oil through expansion reservoir until oil comes out of **one** of the vent plug holes. Stop and install that vent plug. Torque the plug to 180 in-lb (20.3 N-m).
6. Continue to add oil through the expansion reservoir until oil comes out of the remaining vent plug hole on the second transmission. Stop and install that vent plug. Torque the plug to 180 in-lb (20.3 N-m).
7. Continue to add oil through the expansion reservoir until it reaches the FULL COLD line on the expansion reservoir. Proceed to the Bleeding the Hydraulic System section.

Important: Failure to perform the *Bleeding the Hydraulic System* procedure after changing

Mower Deck Maintenance

Servicing the Cutting Blades

Maintain sharp blades throughout the cutting season because sharp blades cut cleanly without tearing or shredding the grass blades. Tearing and shredding turns grass brown at the edges, which slows growth and increases the chance of disease.

Check the cutter blades daily for sharpness, and for any wear or damage. File down any nicks and sharpen the blades as necessary. If a blade is damaged or worn, replace it immediately with a genuine Toro replacement blade. For convenient sharpening and replacement, you may want to keep extra blades on hand.

⚠ WARNING

A worn or damaged blade can break, and a piece of the blade could be thrown into the operator's or bystander's area, resulting in serious personal injury or death.

- Inspect the blade periodically for wear or damage.
- Replace a worn or damaged blade.

Before Inspecting or Servicing the Blades

Park the machine on a level surface, disengage the blade control switch (PTO), and set the parking brake. Turn the ignition key to Off. Remove the key.

Inspecting the Blades

Service Interval: Before each use or daily

1. Inspect the cutting edges (Figure 61). If the edges are not sharp or have nicks, remove and sharpen the blades. Refer to Sharpening the Blades.
2. Inspect the blades, especially the curved area (Figure 61). If you notice any damage, wear, or a slot forming in this area (Figure 61), immediately install a new blade.

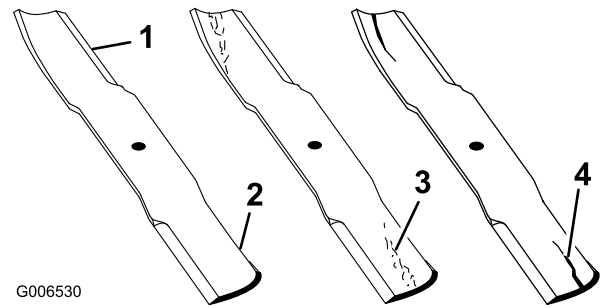

Figure 61

1. Cutting Edge
2. Curved Area
3. Wear/slot Forming
4. Crack

Checking for Bent Blades

Note: The machine must be on a level surface for the following procedure.

1. Raise the mower deck to the highest height-of-cut position; also considered the 'transport' position.
2. While wearing thickly padded gloves or other adequate hand protection slowly rotate blade to be measured into a position that allows effective measurement of the distance between the cutting edge and the level surface the machine is on.

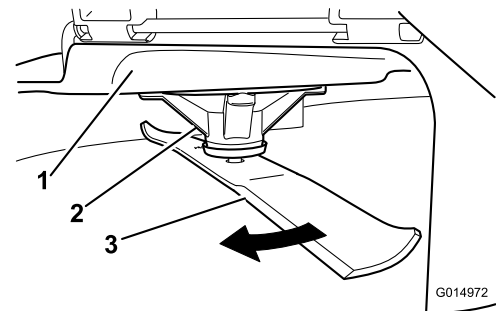

Figure 62

1. Deck
2. Spindle housing
3. Blade

3. Measure from the tip of the blade to the flat surface here.

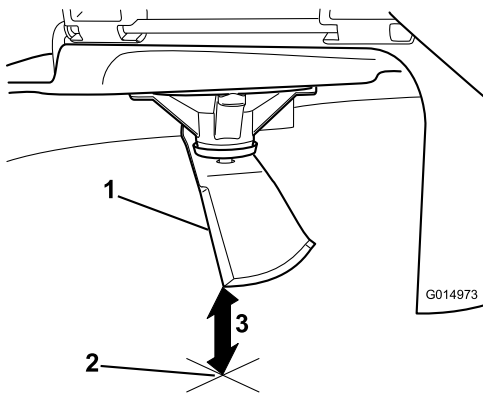

Figure 63

1. Blade, in position for measuring
2. Level surface
3. Measured distance between blade and surface (A)

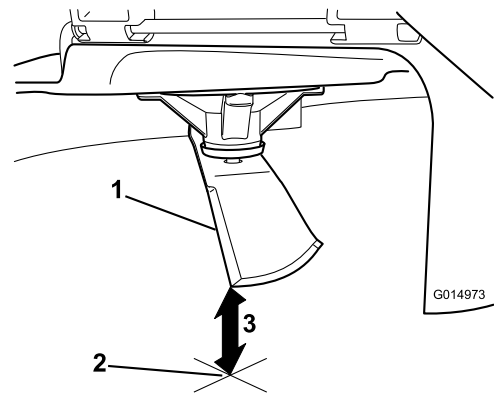

Figure 65

1. Opposing blade edge, in position for measuring
2. Level surface
3. Second measured distance between blade and surface (B)

4. Rotate the same blade 180 degrees so that the opposing cutting edge is now in the same position.

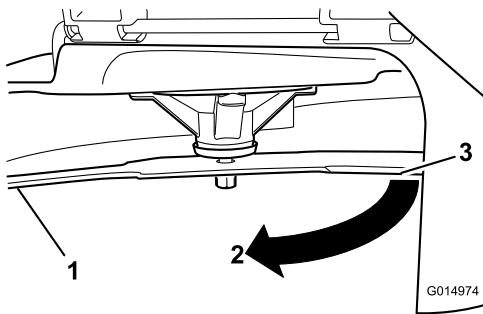

Figure 64

1. Blade, side previously measured
2. Measurement position used previously
3. Opposing side of blade being moved into measurement position

5. Measure from the tip of the blade to the flat surface here. The variance should be no more than 1/8 inch (3mm).

⚠ WARNING

A blade that is bent or damaged could break apart and could seriously injure or kill you or bystanders.

- Always replace bent or damaged blade with a new blade.
- Never file or create sharp notches in the edges or surfaces of blade.

- A. If the difference between A and B is greater than 1/8 inch (3mm) replace the blade with a new blade. Refer to Removing the Blades and Installing the Blades.

Note: If a bent blade is replaced with a new one and the dimension obtained continues to exceed 1/8 inch (3mm), the blade spindle could be bent. Contact an Authorized Toro Dealer for service.

- B. If the variance is within constraints, move to the next blade.

Repeat this procedure on each blade.

Removing the Blades

Blades must be replaced if a solid object is hit, if the blade is out of balance or is bent. To ensure optimum performance and continued safety conformance of the machine, use genuine Toro replacement blades. Replacement blades made by other manufacturers may result in non-conformance with safety standards.

Hold the blade end using a rag or thickly-padded glove. Remove the blade bolt, curved washer, and blade from the spindle shaft (Figure 66).

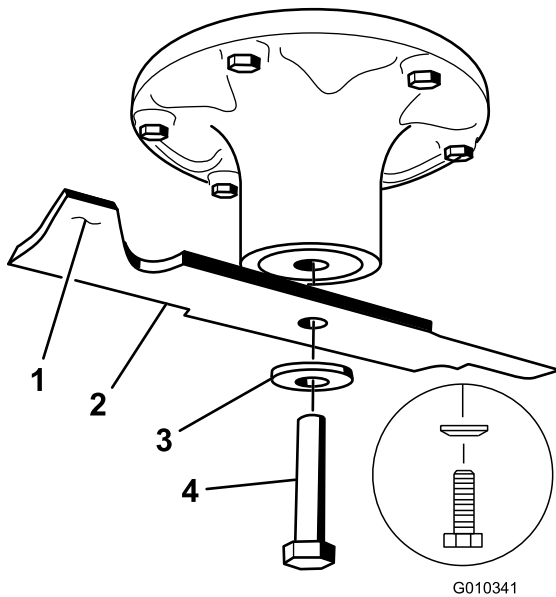

Figure 66

- | | |
|-----------------------|------------------|
| 1. Sail Area of Blade | 3. Curved washer |
| 2. Blade | 4. Blade Bolt |

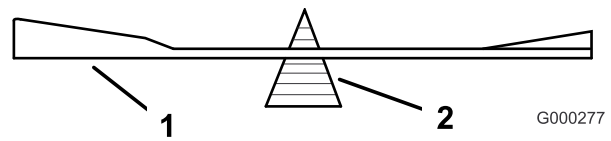

Figure 68

- | | |
|----------|-------------|
| 1. Blade | 2. Balancer |
|----------|-------------|

Sharpening the Blades

⚠ WARNING

When sharpening blade, pieces of blade could be thrown and cause serious injury.

Wear proper eye protection when sharpening blade.

1. Use a file to sharpen the cutting edge at both ends of the blade (Figure 67). Maintain the original angle. The blade retains its balance if the same amount of material is removed from both cutting edges.

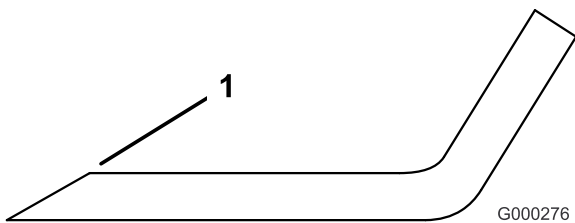

Figure 67

1. Sharpen at original angle
-
2. Check the balance of the blade by putting it on a blade balancer (Figure 68). If the blade stays in a horizontal position, the blade is balanced and can be used. If the blade is not balanced, file some metal off the end of the sail area only (Figure 66). Repeat this procedure until the blade is balanced.

Installing the Blades

1. Install the blade onto the spindle shaft (Figure 66).

Important: The curved part of the blade must be pointing upward toward the inside of the mower to ensure proper cutting.
2. Install the spring disk and blade bolt. The spring disk cone must be installed toward the bolt head (Figure 66). Torque the blade bolt to 100-110 ft-lb (135-150 N-m).

Mower Deck Leveling

Check to ensure the mower deck is level any time you install the mower or when you see an uneven cut on your lawn.

The mower deck must be checked for bent blades prior to leveling; any bent blades must be removed and replaced. Refer to the Checking for Bent Blades procedure before continuing.

The mower deck must be leveled side-to-side first then the front to rear slope can be adjusted.

Requirements:

- The machine must be on a level surface.
- All four tire must be properly inflated. Refer to Checking the Tire Pressure in the Drive System Maintenance section.

Checking Side-to-Side Level

The mower blades must be level from side to side. Check the side-to-side level any time you install the mower or when you see an uneven cut on your lawn.

1. Park the machine on a level surface and disengage the blade control switch.
2. Move the motion control levers outward to the neutral lock position, stop the engine, remove the key, set the parking brake and wait for all moving parts to stop before leaving the operating position.
3. Carefully rotate the blades side to side.
4. Measure between the outside cutting edges and the flat surface (Figure 69). If both measurements

are not within 3/16 inch (5 mm), an adjustment is required; continue to the Leveling procedure.

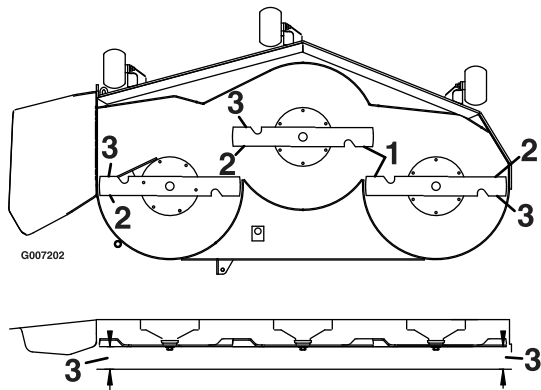

Figure 69

1. Blades side to side
2. Outside cutting edges
3. Measure from the tip of the blade to the flat surface here

Checking the Front-to-Rear Blade Slope

Check the front-to-rear blade level any time you install the mower. If the front of the mower is more than 5/16 inch (7.9 mm) lower than the rear of the mower, adjust the blade level using the following instructions:

1. Park the machine on a level surface and disengage the blade control switch.
2. Move the motion control levers outward to the neutral position, engage the parking brake, stop the engine, remove the key, and wait for all moving parts to stop before leaving the operating position.
3. Carefully rotate the blades so they are facing front to rear (Figure 70).
4. Measure from the tip of the front blade to the flat surface and the tip of the rear blade to the flat surface (Figure 70). If the front blade tip is not 1/16-5/16 inch (1.6-7.9 mm) lower than the rear blade tip, continue to the Leveling the Mower Deck procedure.

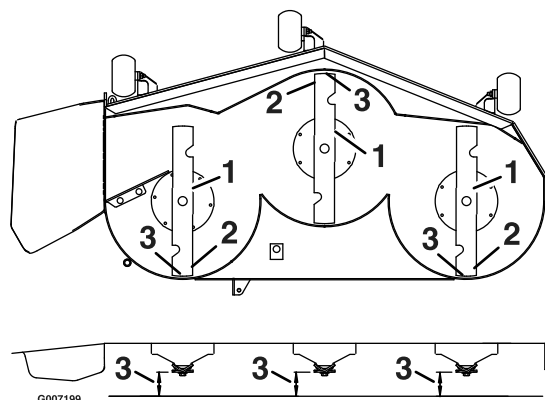

Figure 70

1. Blades front to rear
2. Outside cutting edges
3. Measure from the tip of the blade to the flat surface here

Leveling the Mower Deck

1. Set anti-scalp rollers to top holes or remove completely for this procedure.
2. Set the height-of-cut lever to the 3 inch (76 mm) position.
3. Place two 2-5/8 inch (6.66 cm) blocks under each side of the front edge of the deck, but not under the anti-scalp roller brackets. Place two 2-7/8 inch (7.30 cm) thick blocks under the rear edge of the cutting deck skirt; one on each side of the cutting deck.

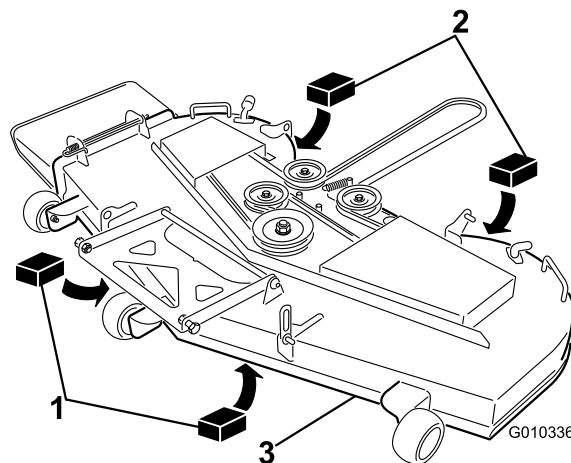

Figure 71

1. Wood block, 2-5/8 inch (6.66 cm) thick
2. Wood block, 2-7/8 inch (7.30 cm) thick
3. Front edge

4. Loosen the leveling adjust locking nuts (item 3) on all four corners so that the deck is sitting securely on all four blocks. Make sure that the deck hangers are all the way down (at the top of the slot) and the deck lift foot lever is pushed back against the stop,

then tighten the four leveling adjust locking nuts (Figure 72).

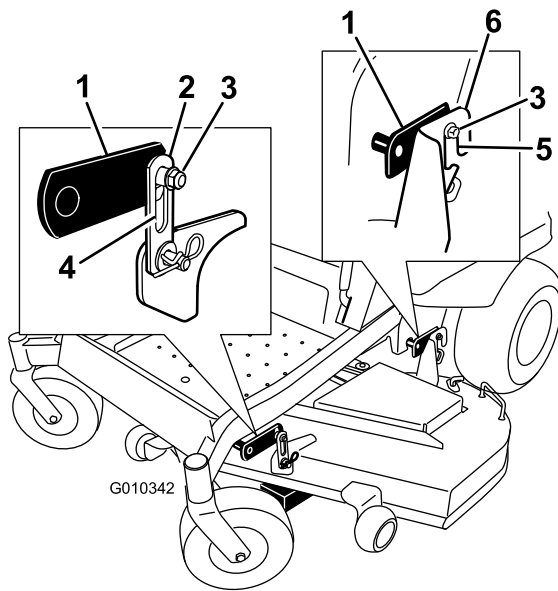

Figure 72

- | | |
|--------------------------------|-------------------------------------|
| 1. Deck lift arm | 4. Slot in deck hanger |
| 2. Deck hanger | 5. Slot in rear deck hanger bracket |
| 3. Leveling adjust locking nut | 6. Rear deck hanger bracket |

5. Recheck that blocks fit just snugly under the deck skirt. Make sure all attachment bolts are tight
6. Verify the deck is level by checking the side-to-side level and front-to-rear blade slope; repeat deck leveling procedure if necessary.

Inspecting the Belts

Service Interval: Every 50 hours

Check the belts for squealing when the belt is rotating, blades slipping when cutting grass, frayed belt edges, burn marks and cracks are signs of a worn mower belt. Replace the mower belt if any of these conditions are evident.

Replacing the Mower Belt

Squealing when the belt is rotating, blades slipping when cutting grass, frayed belt edges, burn marks and cracks are signs of a worn mower belt. Replace the mower belt if any of these conditions are evident.

1. Disengage the blade control switch (PTO), move the motion control levers to the neutral locked position and set the parking brake.
2. Stop the engine, remove the key, and wait for all moving parts to stop before leaving the operating position.

3. Lower the mower to the 3 inch (76 mm) height-of-cut position.
4. For each of the belt covers, loosen the two bolts **but do not remove them**. Slide the cover until it is clear of the bolts and lift it up and out to remove it.
5. Remove the floor pan to access the idler pulley; refer to the Removing the Floor Pan procedure in Premaintenance.
6. Using a spring removal tool, (Toro part no. 92-5771), remove the idler spring from the deck post to remove tension on the idler pulley (Figure 73).

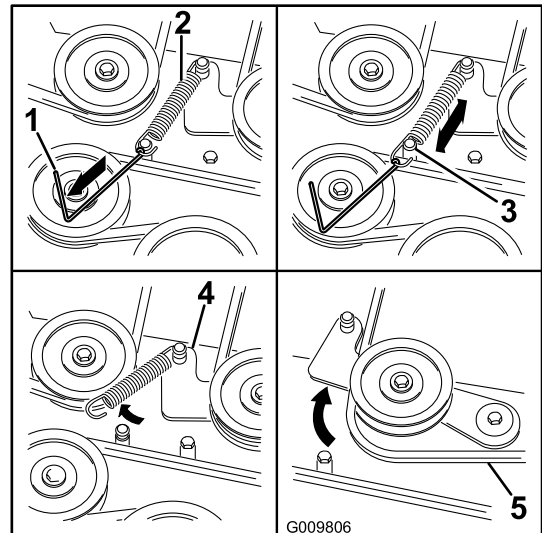

Figure 73

- | | |
|--|---------------|
| 1. Spring removal tool (Toro part no. 92-5771) | 4. Idler arm |
| 2. Idler spring | 5. Mower belt |
| 3. Deck post | |

7. Lower the mower to the lowest height-of-cut. Place the height-of-cut pin in the lock position for lowest height-of-cut.
8. Remove the belt from the mower deck pulleys and remove the existing belt.
9. Install the new belt around the mower pulleys and the clutch pulley under the engine (Figure 73).

▲ WARNING

The spring is under tension when installed and can cause personal injury.

Be careful when removing the belt.

10. Using a spring removal tool, (Toro part no. 92-5771), install the idler spring over the deck post and placing tension on the idler pulley and mower belt (Figure 73).

11. Ensure that the belt is properly seated in all pulleys.
12. To install the belt covers, insert the tabs on the each cover into the corresponding slots on the deck bracket, ensuring that they seat. Rotate the cover to the deck and slide the notches under the loosened bolts until they are seated. Tighten the bolts to secure the cover to the deck.

Removing the Mower

Park the machine on a level surface and disengage the blade control switch. Move the motion control levers outward to the neutral position, engage parking brake, stop the engine, remove the key, and wait for all moving parts to stop before leaving the operating position.

Lower the mower to the 3 inch (76 mm) height-of-cut position. Remove the mower belt from the engine pulley; refer to the Replacing the Mower Belt procedure. Lower the mower to the lowest height-of-cut.

1. Move the spring loaded J-hooks out of the slot in the rear hanger brackets on both sides of the deck (Figure 74).

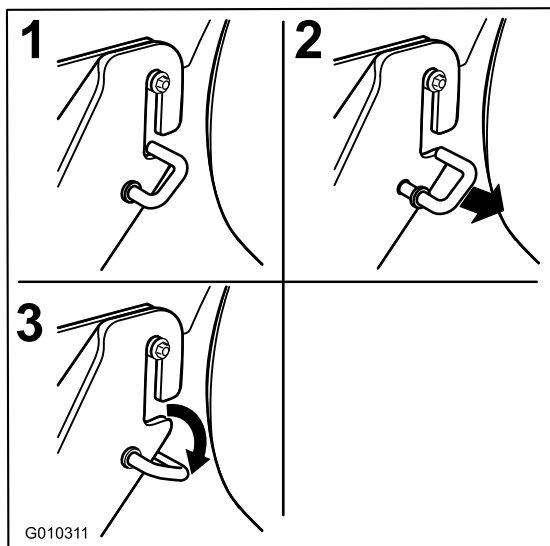

Figure 74

2. Remove the hardware from the front deck hangers on both sides of the deck (Figure 75).
3. Carefully lift the deck off the rear hanger bolts and lower the front of the mower deck to the ground (Figure 75).

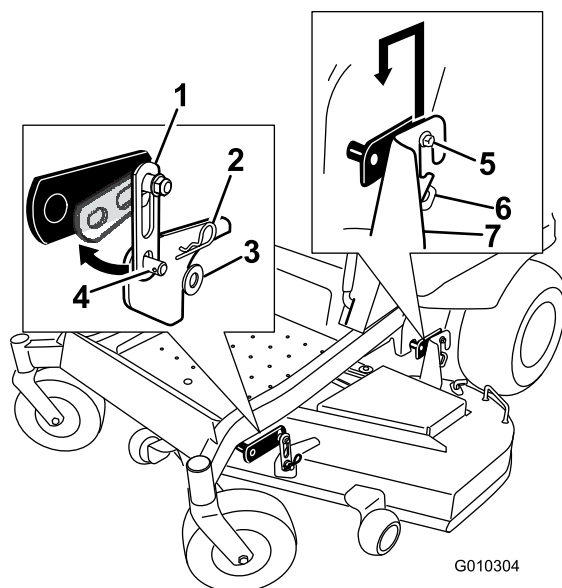

Figure 75

- | | |
|------------------------|-----------------------------|
| 1. Deck hanger | 5. Rear hanger bolts |
| 2. Hairpin cotter | 6. J-hook |
| 3. Washer | 7. Rear deck hanger bracket |
| 4. Welded post on deck | |

4. Raise the height-of-cut to the transport position
5. Slide the mower out from underneath the machine.

Note: Retain all parts for future installation.

Installing the Mower

1. Park the machine on a level surface and disengage the blade control switch.
2. Move the motion control levers outward to the neutral lock position, set the parking brake, stop the engine, remove the key, and wait for all moving parts to stop before leaving the operating position.
3. Slide the mower under the machine.
4. Lower the height-of-cut lever to the lowest position. Place the height-of-cut pin in the lock position for lowest height-of-cut.
5. Lift the rear of the mower deck and guide the hanger brackets over the rear hanger bolts (Figure 75).
6. Attach the front support on the mower deck to the front deck hangers and secure them with a washer and hairpin cotter (Figure 75).
7. Install the mower belt onto the engine pulley; refer to Replacing the Mower Belt.

Replacing the Grass Deflector

Service Interval: Before each use or daily—Inspect the grass deflector for damage

⚠ WARNING

An uncovered discharge opening could allow the lawn mower to throw objects in the operator's or bystander's direction and result in serious injury. Also, contact with the blade could occur.

Never operate the lawn mower unless you install a mulch plate, discharge deflector, or grass collection system.

Inspect the grass deflector for damage before each use. Replace any damaged parts before use.

1. Disengage the spring from the notch in the deflector bracket and slide the rod out of the welded deck brackets, spring, and discharge deflector (Figure 76). Remove the damaged or worn discharge deflector.

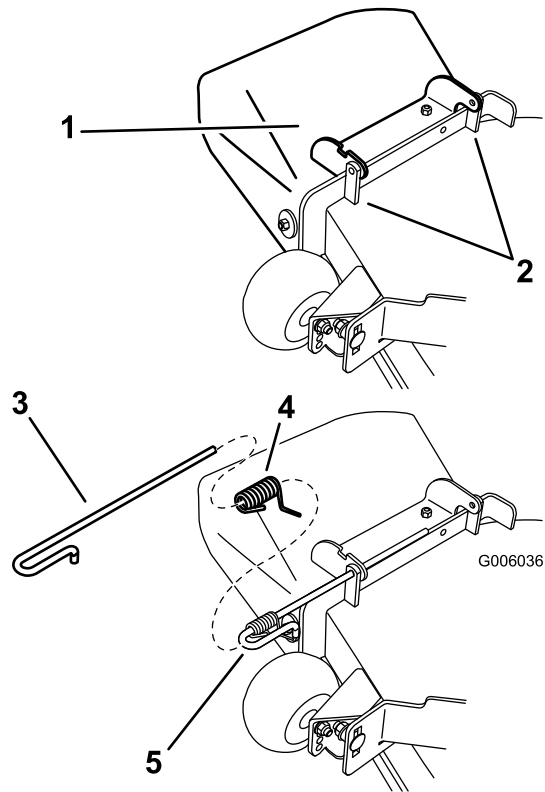

Figure 76

1. Deflector assembly
2. Deck brackets
3. Rod
4. Spring
5. Spring installed over the rod

2. Position the new discharge deflector assembly with the bracket ends between the welded brackets on the deck as shown in Figure 76.
3. Install the spring onto the straight end of the rod. Position the spring on the rod as shown in so the shorter spring end is coming from under the rod before the bend and going over the rod as it returns from the bend.

4. Lift the long end of the spring and place it into the notch on the deflector assembly bracket (Figure 77).

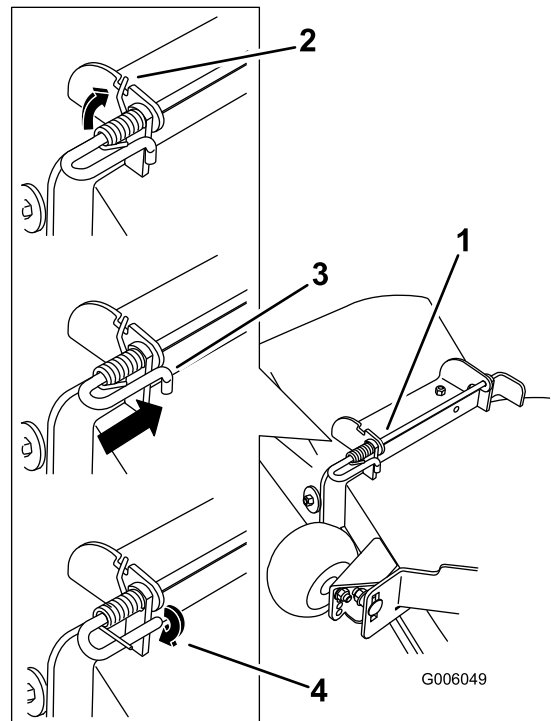

Figure 77

1. Rod and spring assembly partially installed
2. Long end of the spring installed into the notch in the deflector bracket
3. Rod, short end, moved behind mower bracket
4. Short end, retained by mower bracket.

5. Secure the rod and spring assembly by twisting it so the short end of the rod can be placed behind the front bracket welded to the deck (Figure 77).

Important: The grass deflector must be spring loaded in the down position. Lift the deflector up to test that it snaps to the full down position.

Cleaning

Washing the Underside of the Mower

Service Interval: Before each use or daily—Clean the mower housing.

Wash the underside of the mower after each use to prevent grass buildup for improved mulch action and clipping dispersal.

1. Park the machine on a level surface and disengage the blade control switch.
2. Move the motion control levers outward to the neutral lock position, stop the engine, remove the key, and wait for all moving parts to stop before leaving the operating position.
3. Attach the hose coupling to the end of the mower washout fitting, and turn the water on high (Figure 78).

Note: Spread petroleum jelly on the washout fitting O-ring to make the coupling slide on easier and protect the O-ring.

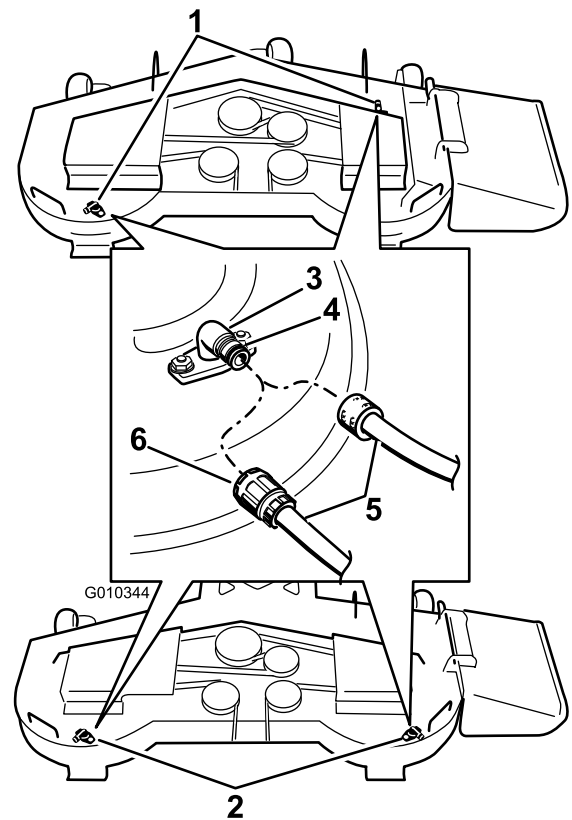

2
Figure 78

- | | |
|---|-------------|
| 1. Washout fitting locations on 54 inch decks | 4. O-ring |
| 2. Washout fitting locations on 48 inch decks | 5. Hose |
| 3. Washout fitting | 6. Coupling |

4. Lower the mower to the lowest height-of-cut.
5. Sit on the seat and start the engine. Engage the blade control switch and let the mower run for one to three minutes.
6. Disengage the blade control switch, stop the engine, and remove the ignition key. Wait for all moving parts to stop.
7. Turn the water off and remove the coupling from the washout fitting.

Note: If the mower is not clean after one washing, soak it and let it stand for 30 minutes. Then repeat the process.

8. Run the mower again for one to three minutes to remove excess water.

⚠ WARNING

A broken or missing washout fitting could expose you and others to thrown objects or blade contact. Contact with blade or thrown debris can cause injury or death.

- **Replace broken or missing washout fitting immediately, before using mower again.**
- **Never put your hands or feet under the mower or through openings in the mower.**

Waste Disposal

Engine oil, batteries, hydraulic oil, and engine coolant are pollutants to the environment. Dispose of these according to your state and local regulations.

Storage

Cleaning and Storage

1. Disengage the blade control switch (PTO), set the parking brake, and turn the ignition key to Off. Remove the key.
2. Remove grass clippings, dirt, and grime from the external parts of the entire machine, especially the engine and hydraulic system. Clean dirt and chaff from the outside of the engine cylinder head fins and blower housing.

Important: You can wash the machine with mild detergent and water. Do not pressure wash the machine. Avoid excessive use of water, especially near the control panel, engine, hydraulic pumps, and motors.

3. Check the brake; refer to Servicing the Brake in the Maintenance Section.
4. Service the air cleaner; refer to Servicing the Air Cleaner in the Maintenance Section.
5. Grease the machine; refer to Greasing and Lubrication in the Maintenance Section.
6. Change the crankcase oil; refer to Servicing the Engine Oil in the Maintenance Section.
7. Check the tire pressure; refer to Checking the Tire Pressure in the Maintenance Section.
8. Change the hydraulic filter; refer to Servicing the Hydraulic System in the Maintenance Section.
9. Charge the battery; refer to Servicing the Battery in the Maintenance Section.
10. Scrape any heavy buildup of grass and dirt from the underside of the mower, then wash the mower with a garden hose.

Note: Run the machine with the blade control switch (PTO) engaged and the engine at high idle for 2 to 5 minutes after washing.

11. Check the condition of the blades; refer to Servicing the Cutting Blades in the Maintenance Section.
12. Prepare the machine for storage when non-use occurs over 30 days. Prepare the machine for storage as follows:
 - A. Add a petroleum based stabilizer/conditioner to fuel in the tank. Follow mixing instructions from the stabilizer manufacturer. Do not use an alcohol based stabilizer (ethanol or methanol).

Note: A fuel stabilizer/conditioner is most effective when mixed with fresh fuel and used at all times.

- B. Run the engine to distribute conditioned fuel through the fuel system (5 minutes).
- C. Stop the engine, allow it to cool, and drain the fuel tank.
- D. Restart the engine and run it until it stops.
- E. Dispose of fuel properly. Recycle as per local codes.

Important: Do not store stabilizer/conditioned fuel over 90 days.

- 13. Check and tighten all bolts, nuts, and screws. Repair or replace any part that is damaged.
- 14. Paint all scratched or bare metal surfaces. Paint is available from your Authorized Service Dealer.
- 15. Store the machine in a clean, dry garage or storage area. Remove the key from the ignition switch and keep it out of reach of children or other unauthorized users. Cover the machine to protect it and keep it clean.

Troubleshooting

| Problem | Possible Cause | Corrective Action |
|--|---|--|
| Starter does not crank | <ol style="list-style-type: none"> 1. Blade control switch (PTO) is engaged. 2. Parking brake is not on. 3. Drive levers are not in neutral lock position. 4. Operator is not seated. 5. Battery is dead. 6. Electrical connections are corroded or loose. 7. Fuse is blown. 8. Relay or switch is defective. | <ol style="list-style-type: none"> 1. Move blade control switch (PTO) to disengaged. 2. Set the parking brake. 3. Ensure the drive levers are in the neutral lock position. 4. Sit on the seat. 5. Charge the battery. 6. Check the electrical connections for good contact. 7. Replace fuse. 8. Contact an Authorized Service Dealer. |
| Engine will not start, starts hard, or fails to keep running | <ol style="list-style-type: none"> 1. Fuel tank is empty. 2. Fuel shutoff valve is closed. 3. Oil level in the crankcase is low. 4. The throttle and choke are not in the correct position. 5. Dirt in fuel filter. 6. Dirt, water, or stale fuel is in the fuel system. 7. Air cleaner is dirty. 8. Seat switch is not functioning properly. 9. Electrical connections are corroded, loose or faulty. 10. Relay or switch is defective. 11. Faulty spark plug. 12. Spark plug wire is not connected. | <ol style="list-style-type: none"> 1. Fill the fuel tank. 2. Open the fuel shutoff valve. 3. Add oil to the crankcase. 4. Be sure the throttle control is midway between the "SLOW" and "FAST" positions, and the choke is in the "ON" position for a cold engine or the "OFF" position for a warm engine. 5. Replace the fuel filter. 6. Contact an Authorized Service Dealer. 7. Clean or replace the air cleaner element. 8. Check the seat switch indicator. Replace seat if needed. 9. Check the electrical connections for good contact. Clean connector terminals thoroughly with electrical contact cleaner, apply dielectric grease and reconnect. 10. Contact an Authorized Service Dealer. 11. Clean, adjust or replace spark plug. 12. Check the spark plug wire connection. |
| Engine loses power. | <ol style="list-style-type: none"> 1. Engine load is excessive. 2. Air cleaner is dirty. 3. Oil level in the crankcase is low. 4. Cooling fins and air passages above the engine are plugged. 5. Vent hole in the fuel cap is plugged. 6. Dirt in the fuel filter. 7. Dirt, water, or stale fuel is in the fuel system. | <ol style="list-style-type: none"> 1. Reduce the ground speed. 2. Clean the air cleaner element. 3. Add oil to the crankcase. 4. Remove the obstruction from the cooling fins and air passages. 5. Clean or replace the fuel cap. 6. Replace the fuel filter. 7. Contact an Authorized Service Dealer. |
| Engine overheats. | <ol style="list-style-type: none"> 1. Engine load is excessive. 2. Oil level in the crankcase is low. 3. Cooling fins and air passages above the engine are plugged. | <ol style="list-style-type: none"> 1. Reduce the ground speed. 2. Add oil to the crankcase. 3. Remove the obstruction from the cooling fins and air passages. |
| Mower pulls left or right (with levers fully forward) | <ol style="list-style-type: none"> 1. Tracking needs adjustment 2. Tire pressure in drive tires not correct. | <ol style="list-style-type: none"> 1. Adjust the tracking. 2. Adjust tire pressure in the drive tires. |

| Problem | Possible Cause | Corrective Action |
|-------------------------|--|--|
| Machine does not drive. | <ol style="list-style-type: none"> 1. By pass valves is not closed tight. 2. Pump belt is worn, loose or broken. 3. Pump belt is off a pulley. 4. Broken or missing idler spring. 5. Hydraulic oil level is low or too hot. | <ol style="list-style-type: none"> 1. Tighten the by pass valves. 2. Change the belt. 3. Change the belt. 4. Replace the spring. 5. Add hydraulic oil to reservoirs or let it cool down. |
| Abnormal vibration. | <ol style="list-style-type: none"> 1. Cutting blade(s) is/are bent or unbalanced. 2. Blade mounting bolt is loose. 3. Engine mounting bolts are loose. 4. Loose engine pulley, idler pulley, or blade pulley. 5. Engine pulley is damaged. 6. Blade spindle is bent. 7. Motor mount is loose or worn. | <ol style="list-style-type: none"> 1. Install new cutting blade(s). 2. Tighten the blade mounting bolt. 3. Tighten the engine mounting bolts. 4. Tighten the appropriate pulley. 5. Contact an Authorized Service Dealer. 6. Contact an Authorized Service Dealer. 7. Contact an Authorized Service Dealer. |
| Uneven cutting height. | <ol style="list-style-type: none"> 1. Blade(s) not sharp. 2. Cutting blade(s) is/are bent. 3. Mower deck is not level. 4. Underside of mower is dirty. 5. Tire pressure is not correct. 6. Blade spindle bent. | <ol style="list-style-type: none"> 1. Sharpen the blade(s). 2. Install new cutting blade(s). 3. Level mower deck from side-to-side and front-to-rear. 4. Clean the underside of the mower. 5. Adjust the tire pressure. 6. Contact an Authorized Service Dealer. |
| Blades do not rotate. | <ol style="list-style-type: none"> 1. Mower deck belt is worn, loose or broken. 2. Mower deck belt is off pulley. 3. Pump drive belt is worn, loose or broken. 4. Broken or missing idler spring. | <ol style="list-style-type: none"> 1. Install new deck belt. 2. Install mower deck pulley and check the idler pulley, idler arm and spring for correct position and function. 3. Check the belt tension or install new belt. 4. Replace the spring. |

Schematics

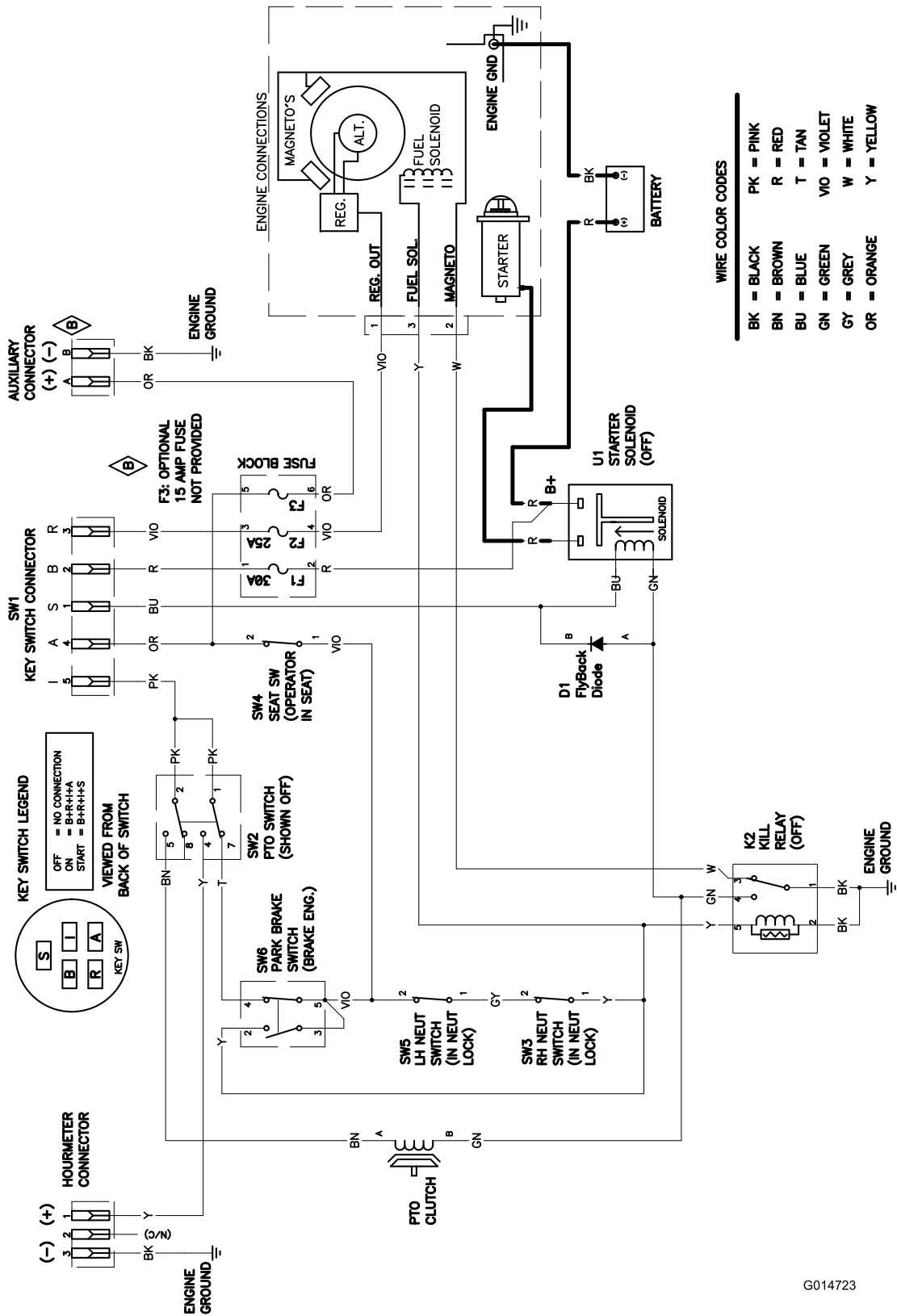

Wire Diagram (Rev. B)

G014723

Notes:

Notes:

Notes:

International Distributor List

| Distributor: | Country: | Phone Number: |
|--------------------------------------|----------------------|----------------------|
| Atlantis Su ve Sulama Sisstemleri Lt | Turkey | 90 216 344 86 74 |
| Balama Prima Engineering Equip. | Hong Kong | 852 2155 2163 |
| B-Ray Corporation | Korea | 82 32 551 2076 |
| Casco Sales Company | Puerto Rico | 787 788 8383 |
| Ceres S.A. | Costa Rica | 506 239 1138 |
| CSSC Turf Equipment (pvt) Ltd. | Sri Lanka | 94 11 2746100 |
| Cyril Johnston & Co. | Northern Ireland | 44 2890 813 121 |
| Equiver | Mexico | 52 55 539 95444 |
| Femco S.A. | Guatemala | 502 442 3277 |
| G.Y.K. Company Ltd. | Japan | 81 726 325 861 |
| Geomechaniki of Athens | Greece | 30 10 935 0054 |
| Guandong Golden Star | China | 86 20 876 51338 |
| Hako Ground and Garden | Sweden | 46 35 10 0000 |
| Hako Ground and Garden | Norway | 47 22 90 7760 |
| Hayter Limited (U.K.) | United Kingdom | 44 1279 723 444 |
| Hydroturf Int. Co Dubai | United Arab Emirates | 97 14 347 9479 |
| Hydroturf Egypt LLC | Egypt | 202 519 4308 |
| Ibea S.P.A. | Italy | 39 0331 853611 |
| Irriamc | Portugal | 351 21 238 8260 |
| Irrigation Products Int'l Pvt Ltd. | India | 86 22 83960789 |
| Jean Heybroek b.v. | Netherlands | 31 30 639 4611 |
| Lely (U.K.) Limited | United Kingdom | 44 1480 226 800 |
| Maquiver S.A. | Colombia | 57 1 236 4079 |
| Maruyama Mfg. Co. Inc. | Japan | 81 3 3252 2285 |
| Metra Kft | Hungary | 36 1 326 3880 |
| Mountfield a.s. | Czech Republic | 420 255 704 220 |
| Munditol S.A. | Argentina | 54 11 4 821 9999 |
| Oslinger Turf Equipment SA | Ecuador | 593 4 239 6970 |
| Oy Hako Ground and Garden Ab | Finland | 358 987 00733 |
| Parkland Products Ltd. | New Zealand | 64 3 34 93760 |
| Prochaska & Cie | Austria | 43 1 278 5100 |
| RT Cohen 2004 Ltd. | Israel | 972 986 17979 |
| Riversa | Spain | 34 9 52 83 7500 |
| Sc Svend Carlsen A/S | Denmark | 45 66 109 200 |
| Solvert S.A.S. | France | 33 1 30 81 77 00 |
| Spypros Stavrinides Limited | Cyprus | 357 22 434131 |
| Surge Systems India Limited | India | 91 1 292299901 |
| T-Markt Logistics Ltd. | Hungary | 36 26 525 500 |
| Toro Australia | Australia | 61 3 9580 7355 |
| Toro Europe BVBA | Belgium | 32 14 562 960 |



The Toro Warranty

Conditions and Products Covered

The Toro® Company and its affiliate, Toro Warranty Company, pursuant to an agreement between them, jointly promise to repair the Toro Product listed below if used for residential purposes* if defective in materials or workmanship.

The following time periods apply from the date of purchase:

| Products | Warranty Period |
|-----------------------------|-------------------------|
| Walk Power Mowers | 2 year limited warranty |
| Rear Engine Riders | 2 year limited warranty |
| Lawn & Garden Tractors | 2 year limited warranty |
| Electric Hand Held Products | 2 year limited warranty |
| Snowthrowers | 2 year limited warranty |
| Consumer Zero Turn | 2 year limited warranty |

*Original Purchaser means the person who originally purchased the Toro Product

*Residential purposes means use of the product on the same lot as your home. Use at more than one location, or institutional or rental use, is considered commercial use, and the commercial use warranty would apply.

Limited Warranty for Commercial Use

Toro Consumer Products and attachments used for commercial, institutional, or rental use, are warranted against defects in materials or workmanship for the following time periods from the date of original purchase:

| Products | Warranty Period |
|-----------------------------|------------------------|
| Walk Power Mowers | 90 day warranty |
| Rear Engine Riders | 90 day warranty |
| Lawn & Garden Tractors | 90 day warranty |
| Electric Hand Held Products | 90 day warranty |
| Snowthrowers | 90 day warranty |
| Consumer Zero Turn | 45 day warranty |

Instructions for Obtaining Warranty Service

If you think that your Toro Product contains a defect in materials or workmanship, follow this procedure:

1. Contact your seller to arrange service of the product. If for any reason it is impossible for you to contact your seller, you may contact any Toro Authorized Distributor to arrange service.
2. Bring the product and your proof of purchase (sales receipt) to the Service Dealer. If for any reason you are dissatisfied with the Service Dealer's analysis or with the assistance provided, contact us at:

Customer Care Department, Consumer Division
 The Toro Company
 8111 Lyndale Avenue South
 Bloomington, MN 55420-1196
 Manager: Technical Product Support: 001-952-887-8248

See attached Distributor List

Owner Responsibilities

You must maintain your Toro Product by following the maintenance procedures described in the *Operator's Manual*. Such routine maintenance, whether performed by a dealer or by you, is at your expense.

Items and Conditions Not Covered

This express warranty does not cover the following:

- Cost of regular maintenance service or wear parts, such as rotor blades (paddles), scraper blades, belts, fuel, lubricants, oil changes, spark plugs, cable/linkage or brake adjustments
- Any product or part which has been altered or misused and requires replacement or repair due to accidents or lack of proper maintenance
- Repairs necessary due to failure to use fresh fuel (less than one month old), or failure to properly prepare the unit prior to any period of non-use over one month
- Engine and transmission. These are covered by the appropriate manufacturer's guarantees with separate terms and conditions

All repairs covered by these warranties must be performed by an Authorized Toro Service Dealer using Toro approved replacement parts.

General Conditions

The purchaser is covered by the national laws of each country. The rights to which the purchaser is entitled with the support of these laws are not restricted by this warranty.