



**Count on it.**

**Parts Catalog**

**Z Master® G3 Riding Mower  
with 48in TURBO FORCE® Side Discharge  
Mower**

**Model No. 74901—Serial No. 311000001 and Up**

# Ordering Replacement Parts

To order replacement parts, please supply the part number, the quantity, and the description of each part desired.

## Understanding Reference Numbers

Each identified part in an illustration has a reference number. The reference number for a part also appears in the parts list, along with other information about the part.

This catalog uses two special reference number formats, one to indicate parts in a service assembly and another to indicate the quantity of a given part in an illustration.

## Service Assembly Reference Numbers

Parts in service assemblies have reference numbers in the form a:b. The a represents the reference number of the entire service assembly and the b represents a sequential number unique to each part within the service assembly.

For example, a wheel assembly might be identified by reference number 6, the tire by 6:1, the valve by 6:2, and the wheel by 6:3. When you order the assembly identified by reference number 6, you receive all parts identified by reference numbers 6:1, 6:2, and 6:3. However, you may also order any part individually. Reference numbers of this type appear in illustration and in parts lists.

## Reference Numbers Indicating Quantity

In an illustration, if a reference number indicates more than one part, the reference number has the form nX y. The n represents the quantity of the part, the X is the multiplication symbol, and the y represents the reference number.

For example, in an illustration, the reference number 2X 37 means that two of the parts identified by reference number 37 are indicated.

# List of Abbreviations

**AR:** as required

**ASM:** assembly

**BBC:** blade brake control

**BHTF:** button head thread forming

**CARR:** carriage

**CCW:** counter clockwise

**CW:** clockwise

**DEG:** degrees

**DPA:** Dual Point Adjustment

**ECM:** electronic control module

**EXT:** external

**FH:** flat head

**GA:** gauge

**HD:** heavy-duty

**HF:** hex flange

**HH:** hex head

**HHF:** hex head flange

**HHFTF:** hex head flange thread forming

**HJ:** hex jam

**HLH:** hex lag head

**HOC:** height-of-cut

**HSBH:** hex socket button head

**HSFH:** hex socket flat head

**HSH:** hex socket head

**HWH:** hex washer head

**HWTF:** hex washer head thread forming

**HYD:** hydraulic

**LH:** left hand

**LP:** Liquid Propane

**NI:** nylon insert

**NPTF:** national pipe thread fine

**PFH:** phillips flat head

**PPH:** phillips pan head

**PPHTF:** phillips pan head thread forming

**PRH:** phillips round head

**PTH:** phillips truss head

**PTO:** power-take-off

**RH:** right hand

**ROPS:** roll-over protection system

**RRB:** rear roller brush

**SFH:** slotted fillister head

**SHH:** slotted hex head

**SHWH:** slotted hex washer head

**SPH:** slotted pan head

**SQH:** square head

**SRH:** slotted round head

**STD:** standard

**TAP:** self tapping

**TTH:** torx truss head

# Contents

Front Frame and Caster Wheel Assembly .....	4
Roll-Over Protection System Assembly No. 116-0231 .....	5
Caster Wheel and Fork Assembly .....	6
Hydraulic Pump, Idler and Belt Assembly .....	7
Pump Idler Assembly No. 116-1255 .....	8
LH Hydro Assembly No. 116-1322 .....	9
RH Hydro Assembly No. 116-1323 .....	10
Rear Wheel and Park Brake Assembly .....	11
Brake Handle Assembly No. 116-1878 .....	12
Fuel Tank Mounting Assembly .....	13
Fuel Tank Assembly No. 116-3979 .....	14
Seat Mounting Assembly .....	15
Seat Assembly No. 116-0035 .....	16
Motion Control Assembly .....	17
Fender, Console and Control Assembly .....	18
LH Console Assembly No. 115-7403 .....	19
RH Console Assembly No. 115-7402 .....	20
Electrical System Assembly .....	21
Deck Lift Assembly .....	22
Height-of-Cut Assembly No. 109-7438 .....	23
Engine, Clutch and Muffler Assembly .....	24
Deck Assembly .....	25
Deck Decal Assembly No. 114-5805 .....	26
Idler Assembly .....	27
Spindle Assembly No. 119-8560 .....	28
Rubber Deflector Assembly No. 108-7770 .....	29
Attachments and Accessories .....	30

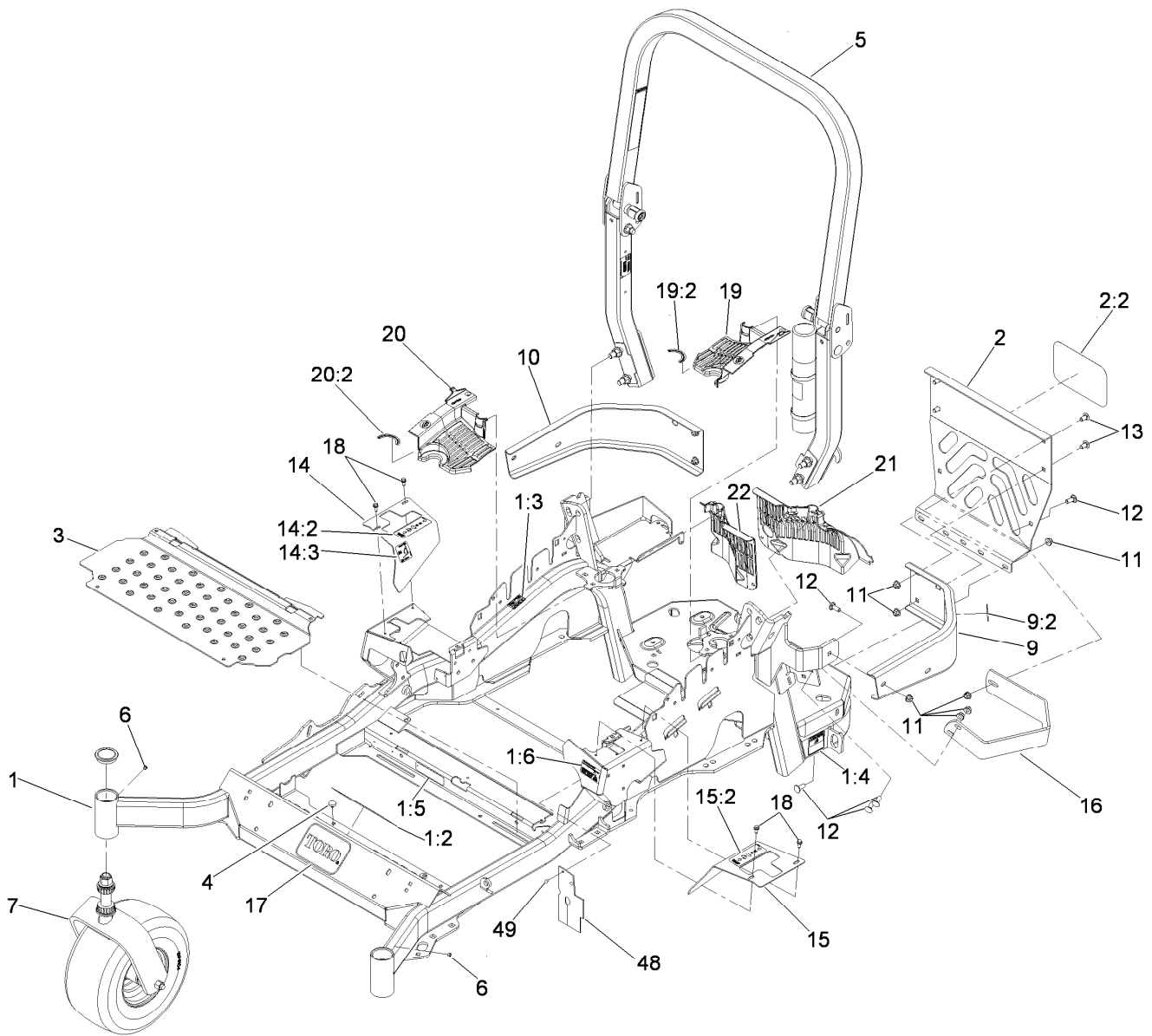

## Front Frame and Caster Wheel Assembly

Ref.	Part Number	Qty.	Description	Ref.	Part Number	Qty.	Description
1	116-2124	1	Main Frame ASM	14	116-0579	1	RH Motion Control Cover ASM
1:2	116-3303	1	Decal-Slope	14:2	109-7232	1	Decal-Motion Control
1:3	103-2076	2	Decal-Caution	14:3	109-7929	1	Decal-Park Brake
1:4	116-0205	2	Decal-Belt Drive	15	116-0580	1	LH Motion Control Cover ASM
1:5	117-2718	1	Decal-Arrester, Spark	15:2	109-7232	1	Decal-Motion Control
1:6	116-1654	1	Decal Fuel Fill	16	116-0043-03	1	Guard-Muffler
2	115-7410	1	Rear Guard ASM	17	68-3640	1	Decal
2:2	67-7320	1	Decal	18	32144-10	4	Screw-HWH
3	116-0024-01	1	Floorpan	19	116-0170	1	LH Hydro Guard ASM
4	1-513658	2	Bumper	19:2	116-0157	1	Decal-Hydro Oil
5	116-0231	1	ROPS ASM	20	116-0171	1	RH Hydro Guard ASM
6	1-811010	2	Plug	20:2	116-0157	1	Decal-Hydro Oil
7		2	Front Caster ASM ●	21	109-9057	1	Guard-Hydro, Rear LH
9	116-0180	1	LH Bumper ASM	22	109-9058	1	Guard-Hydro, Rear RH
9:2	103-2076	1	Decal-Caution	48	116-2362	1	Deflector, Air Flow
10	116-0057-03	1	Bumper-RH	49	1-803035	2	Rivet-Pop
11	104-8301	11	Nut-Flange, NI				
12	3231-22	7	Screw-CARR				
13	3231-21	4	Screw-CARR				

● Not serviced separately

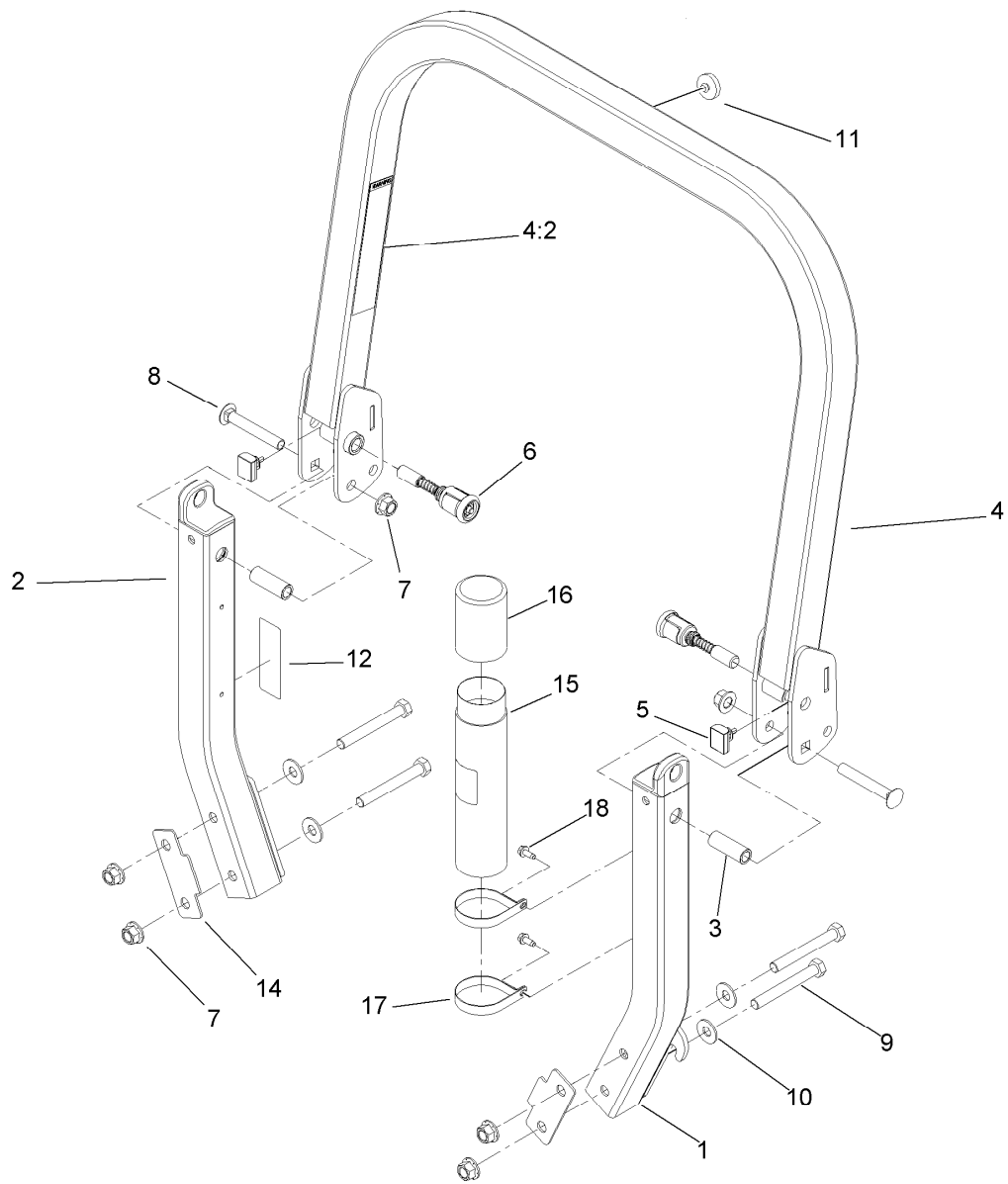

## Roll-Over Protection System Assembly No. 116-0231

Ref.	Part Number	Qty.	Description	Ref.	Part Number	Qty.	Description
1		1	LH ROPS Leg ASM ●	9	325-17	4	Screw-HH
2		1	RH ROPS Leg ASM ●	10	109-9505	4	Washer-Spring
3	109-6653	2	Spacer	11	109-9233	1	Bumper-Push-In, Rubber
4		1	Upper ROPS ASM ●	12	116-0090	1	Decal-Caution
4:2	107-2102	1	Decal-Warning, Folding ROPS	14	116-0960	2	Spacer
5	109-5337	2	Bumper-ROPS	15	104-7050	1	Tube-Manual
6	116-0104	2	Spring Pin ASM	16	104-7048	1	Cap-Housing
7	99-5107	6	Nut-Lock	17	107-1865	2	R-Clamp
8	3233-10	2	Screw-CARR	18	32144-10	2	Screw-HWH

● Not serviced separately

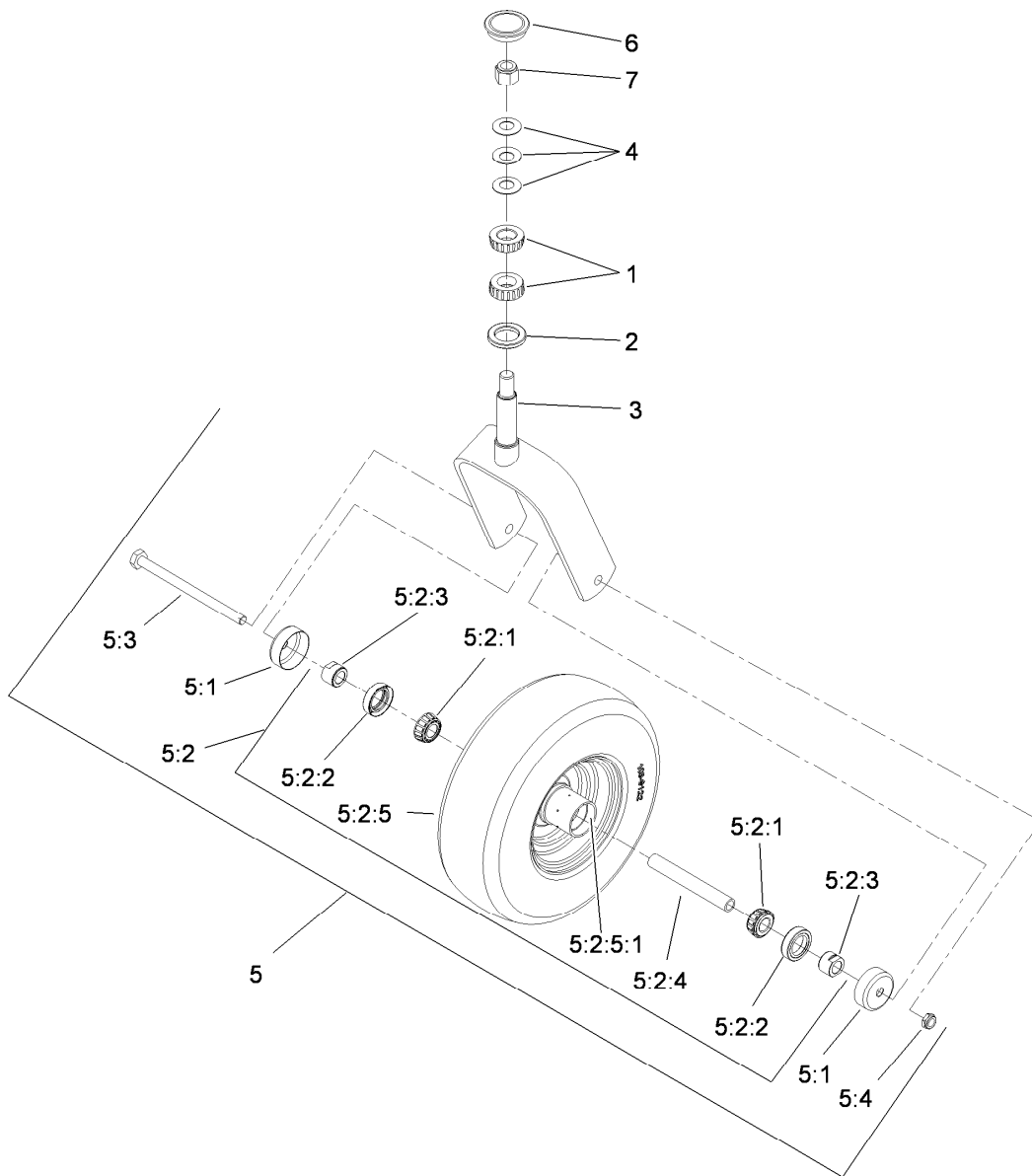

## Caster Wheel and Fork Assembly

<i>Ref.</i>	<i>Part Number</i>	<i>Qty.</i>	<i>Description</i>	<i>Ref.</i>	<i>Part Number</i>	<i>Qty.</i>	<i>Description</i>
1	1-543509	2	Bearing-Roller, Tapered	5:2:3	103-3051	2	Spacer-Nut
2	1-543511	1	Seal-Grease	5:2:4	103-3155	1	Axle-Caster
3	109-9422-01	1	Fork-Caster	5:2:5		1	Wheel And Tire ASM ●
4	1-633508	3	Washer-Bellville	5:2:5:1	1-633584	1	Bearing-Cup
5	109-9126	1	Wheel And Tire ASM	5:3	325-42	1	Screw-HH
5:1	103-2768	2	Guard-Seal	5:4	3296-23	1	Nut-Lock, NI
5:2		1	Wheel And Tire ASM ●	6	103-4882	1	Cap-Grease
5:2:1	1-633585	2	Bearing-Cone, Taper	7	3296-51	1	Nut-Lock, NI
5:2:2	103-0063	2	Seal-Caster				

● Not serviced separately

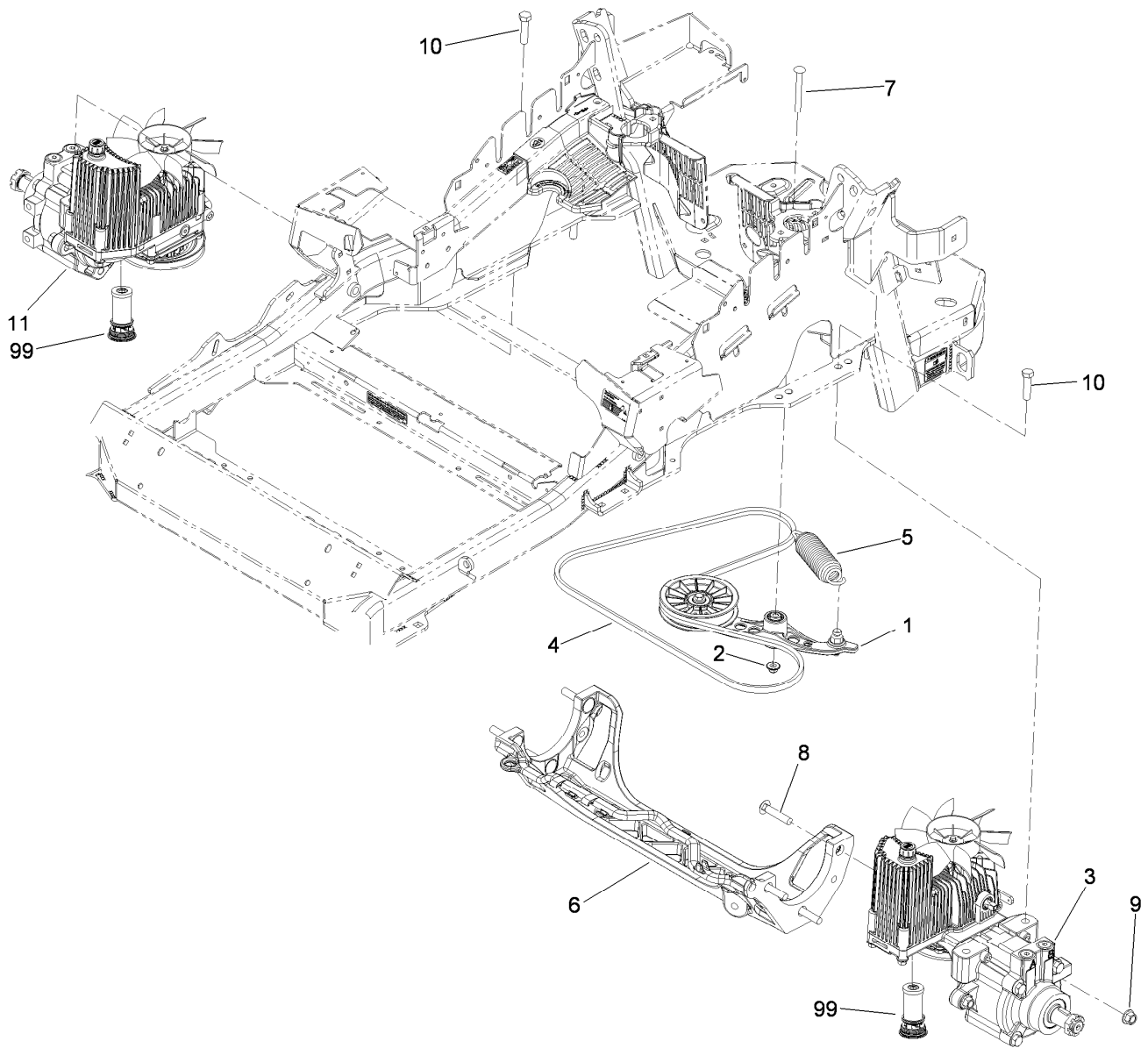

## Hydraulic Pump, Idler and Belt Assembly

Ref.	Part Number	Qty.	Description
1	116-1255	1	Pump Idler ASM
2	109-6658	1	Nut-Flange, NI
3	116-1322	1	LH Hydro ASM (12Cc W/Check)
4	109-3388	1	Belt
5	116-0133	1	Extension-Spring
6	109-9375	1	Cradle-Hydro
7	116-1502	1	Bolt-Shoulder, Carriage
8	3233-34	6	Screw-CARR
9	99-5107	6	Nut-Lock
10	325-8	4	Screw-HH
11	116-1323	1	RH Hydro ASM (12Cc W/Check)
99	114-4713	1	Hypr-Oil 500 (Quart) ●
99	114-4714	1	Hypr-Oil 500 (Gallon) ●
99	114-4715	1	Hypr-Oil 500-5 (5 Gallon) ●
99	117-0390	1	Filter-Hydro

● Not illustrated



## Pump Idler Assembly No. 116-1255

Ref.	Part Number	Qty.	Description
1		1	Arm-Pump, Idler ●
2	43-0940	1	Spacer
3	103-3504	2	Bearing-Spherical
4	103-3505	1	Seal-Double Lip
5	103-3506	1	Seal-Single Lip
6	109-6658	1	Nut-Flange, NI
7	106-7159	2	O-Ring
8	323-8	1	Screw-HH
9	32120-10	2	Ring-Snap
10	302-19	1	Fitting-Grease
11	109-8076	1	Pulley-Idler
12	109-7399	1	Pin-Anchor, Spring

● Not serviced separately

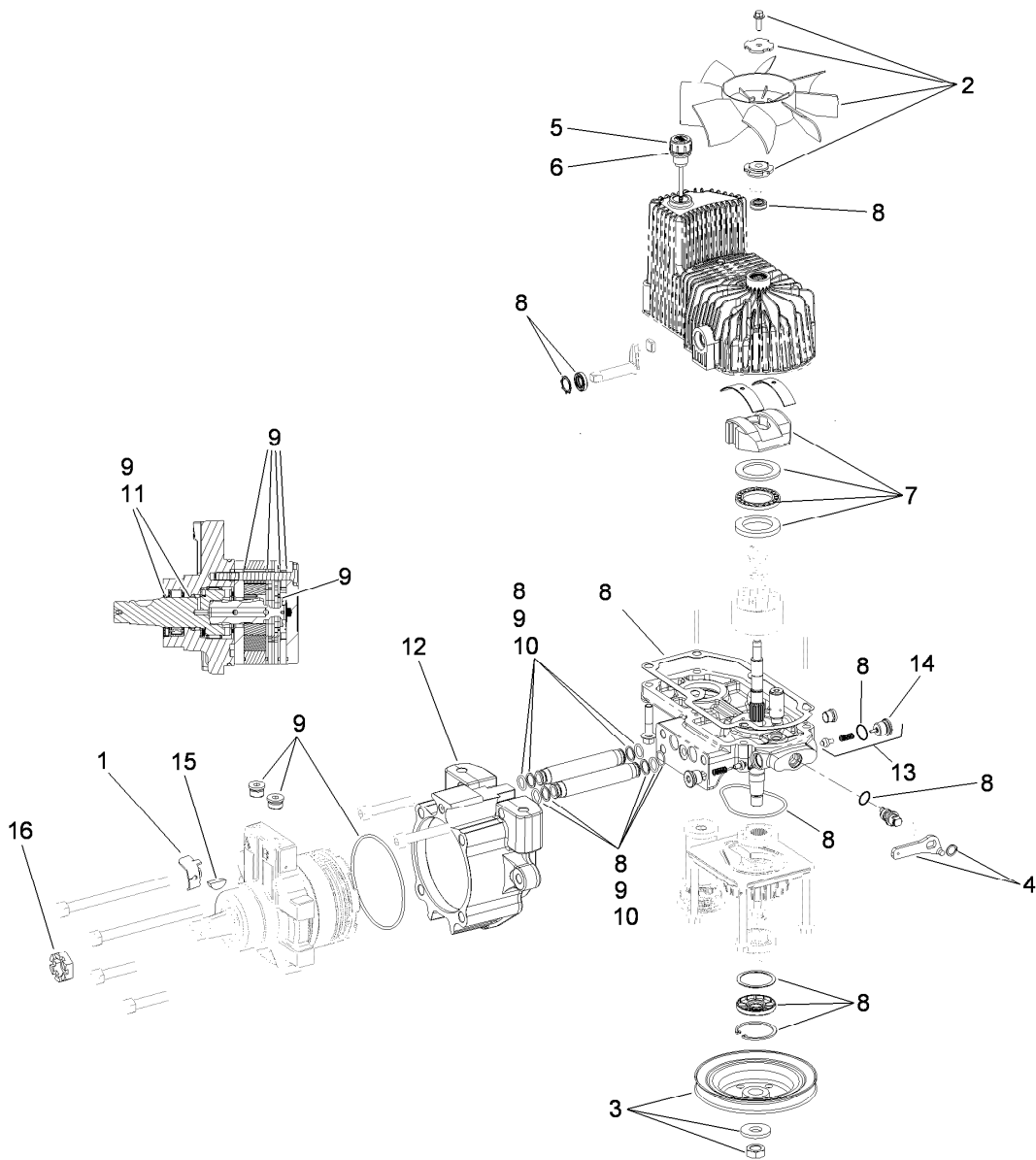

## LH Hydro Assembly No. 116-1322

<i>Ref.</i>	<i>Part Number</i>	<i>Qty.</i>	<i>Description</i>	<i>Ref.</i>	<i>Part Number</i>	<i>Qty.</i>	<i>Description</i>
1	116-1758	1	Bracket-Anchor, Cable	9	116-1369	1	Motor Seal Kit
2	116-0233	1	Fan Kit	10	116-1370	1	Tube Seal Kit
3	116-0234	1	Pulley Kit	11	116-1371	1	Output Shaft Seal Kit
4	116-0235	1	Handle-Bypass Valve, Hydro	12	116-1372	1	Cup-Nose
5	116-0236	1	Dipstick-Hydro W/Gasket	13	116-1630	1	Check Valve ASM
6	116-0237	1	Gasket-Dipstick, Hydro	14	116-1631	1	Plug-Check, W/O-Ring
7	116-1367	1	Swash Block Kit	15	3257-42	1	Key-Woodruff
8	116-1368	1	Pump Seal Kit	16	1-809036	1	Nut-HH
				99	116-1373	1	Flow Test Kit ●

● Not illustrated

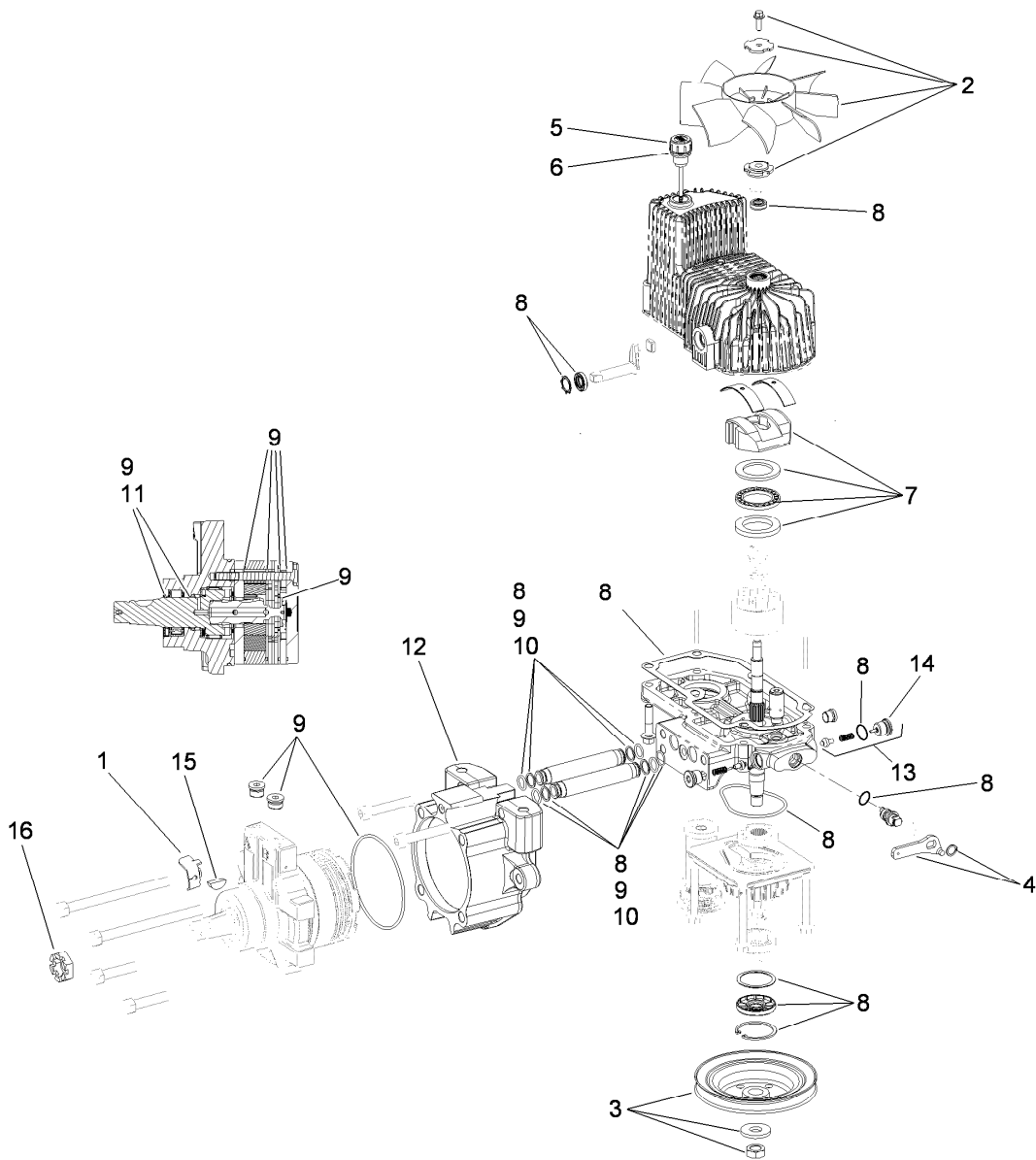

## RH Hydro Assembly No. 116-1323

<i>Ref.</i>	<i>Part Number</i>	<i>Qty.</i>	<i>Description</i>	<i>Ref.</i>	<i>Part Number</i>	<i>Qty.</i>	<i>Description</i>
1	116-1758	1	Bracket-Anchor, Cable	9	116-1369	1	Motor Seal Kit
2	116-0233	1	Fan Kit	10	116-1370	1	Tube Seal Kit
3	116-0234	1	Pulley Kit	11	116-1371	1	Output Shaft Seal Kit
4	116-0235	1	Handle-Bypass Valve, Hydro	12	116-1372	1	Cup-Nose
5	116-0236	1	Dipstick-Hydro W/Gasket	13	116-1630	1	Check Valve ASM
6	116-0237	1	Gasket-Dipstick, Hydro	14	116-1631	1	Plug-Check, W/O-Ring
7	116-1367	1	Swash Block Kit	15	3257-42	1	Key-Woodruff
8	116-1368	1	Pump Seal Kit	16	1-809036	1	Nut-HH
				99	116-1373	1	Flow Test Kit ●

● Not illustrated

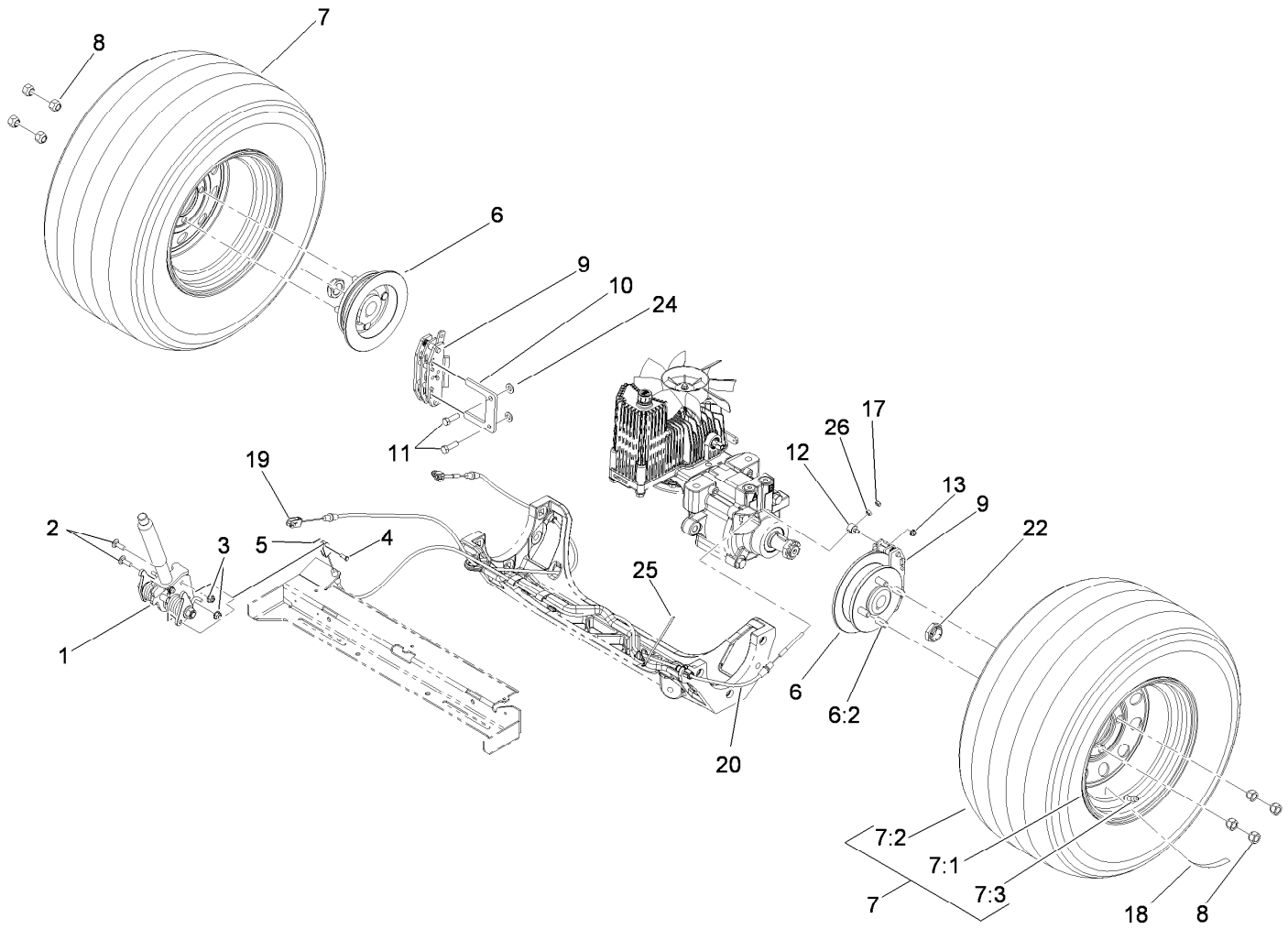

## Rear Wheel and Park Brake Assembly

Ref.	Part Number	Qty.	Description	Ref.	Part Number	Qty.	Description
1	116-1878	1	Brake Handle ASM	10	109-0958	2	Plate-Mount, Brake
2	3230-2	2	Bolt-CARR	11	92-5727	4	Screw-Lock, Patch
3	104-8300	2	Nut-Flange, NI	12	112-8379	2	Swivel
4	60-1730	2	Pin-Clevis	13	104-7201	2	Nut-HF
5	3272-1	2	Pin-Cotter	17	3296-13	2	Nut-Lock, NI
6	116-1746	2	Wheel Hub ASM	18	116-2643	2	Decal-Wheel Nut Torque
6:2	116-1696	4	Stud-Wheel	19	115-3584	1	Cable
7	115-3590	2	Wheel And Tire ASM	20	115-3585	1	Cable
7:1	109-3645	1	Rim ASM	22	116-1399	2	Locknut
7:2	1-653160	1	Tire	24	3256-24	4	Washer-Flat
7:3	232-27	1	Stem-Valve	25	116-0940	1	Tie-Cable
8	242-50	8	Nut-Lug	26	3219-1	2	Nut-Hex
9	109-2889	2	Caliper-Brake				



## Brake Handle Assembly No. 116-1878

<i>Ref.</i>	<i>Part Number</i>	<i>Qty.</i>	<i>Description</i>	<i>Ref.</i>	<i>Part Number</i>	<i>Qty.</i>	<i>Description</i>
1	99-5107	1	Nut-Lock	10	115-3581	1	Rod-Release, Brake
2	117-0380	1	Spacer	11	115-3592	1	Grip
3	115-3580	1	Arm-Brake, LH	12	112-8387	1	Bolt-Shoulder
4	117-0376	1	Spring-Torsion, RH	13	117-0375	1	Spring-Torsion, LH
5	115-3574	1	Plate-Latch	14	115-3579	1	Arm-Brake, RH
6	104-7201	1	Nut-HF	15	117-0379	1	Bolt-Shoulder
7	116-1876-03	1	Brake Handle ASM	16	3256-26	1	Washer-Flat
8	114-1207	1	Washer-Special	17	115-2750	1	Knob
9	114-8187	1	Spring-Compression				

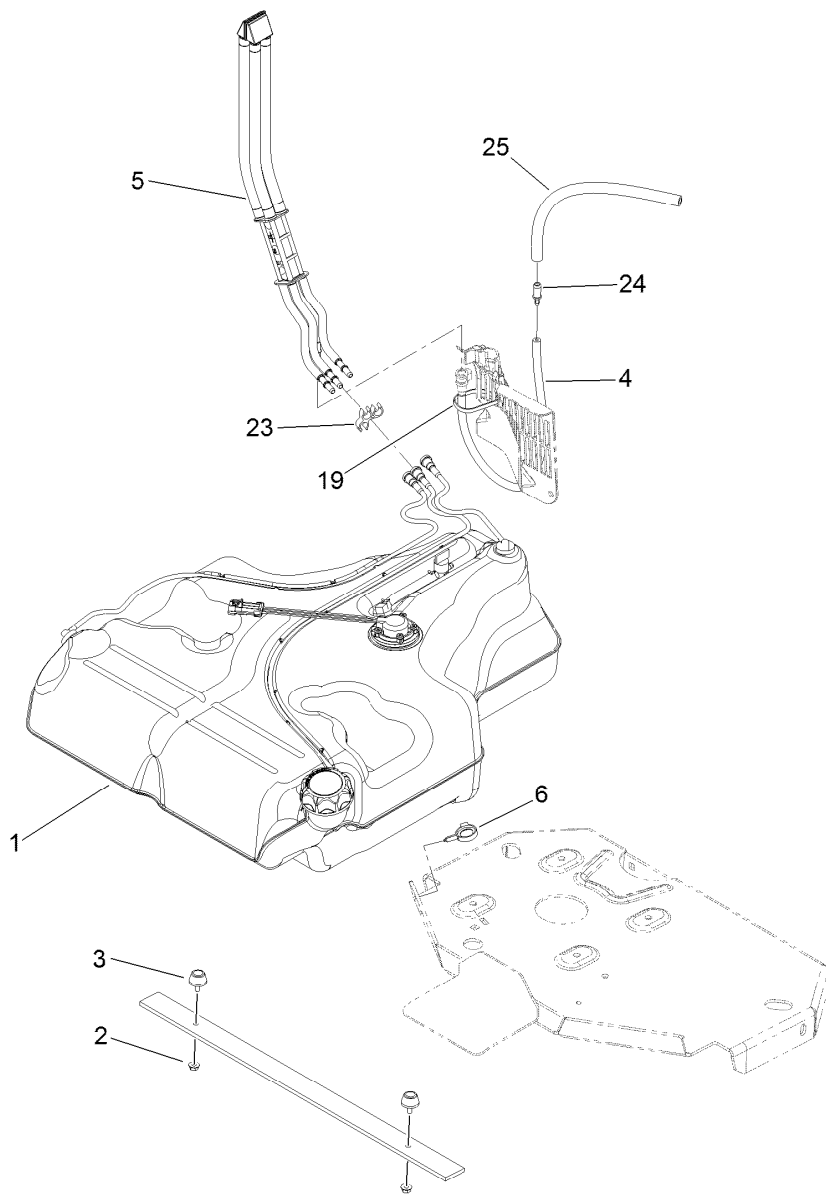

## Fuel Tank Mounting Assembly

Ref.	Part Number	Qty.	Description
1	116-3979	1	Fuel Tank ASM
2	32128-33	2	Nut-HF
3	109-2365	2	Rubber Bumper ASM (W/Stud)
4	116-3977	1	Hose ASM
5	109-9491	1	Fuel Manifold Vent ASM
6	105-1853	1	Clamp-Hose
19	1-303335	1	Tie-Plastic
23	116-3370	1	Clip-Spacer
24	98-2952	1	Fitting-Straight
25	116-4344	1	Hose-Fuel

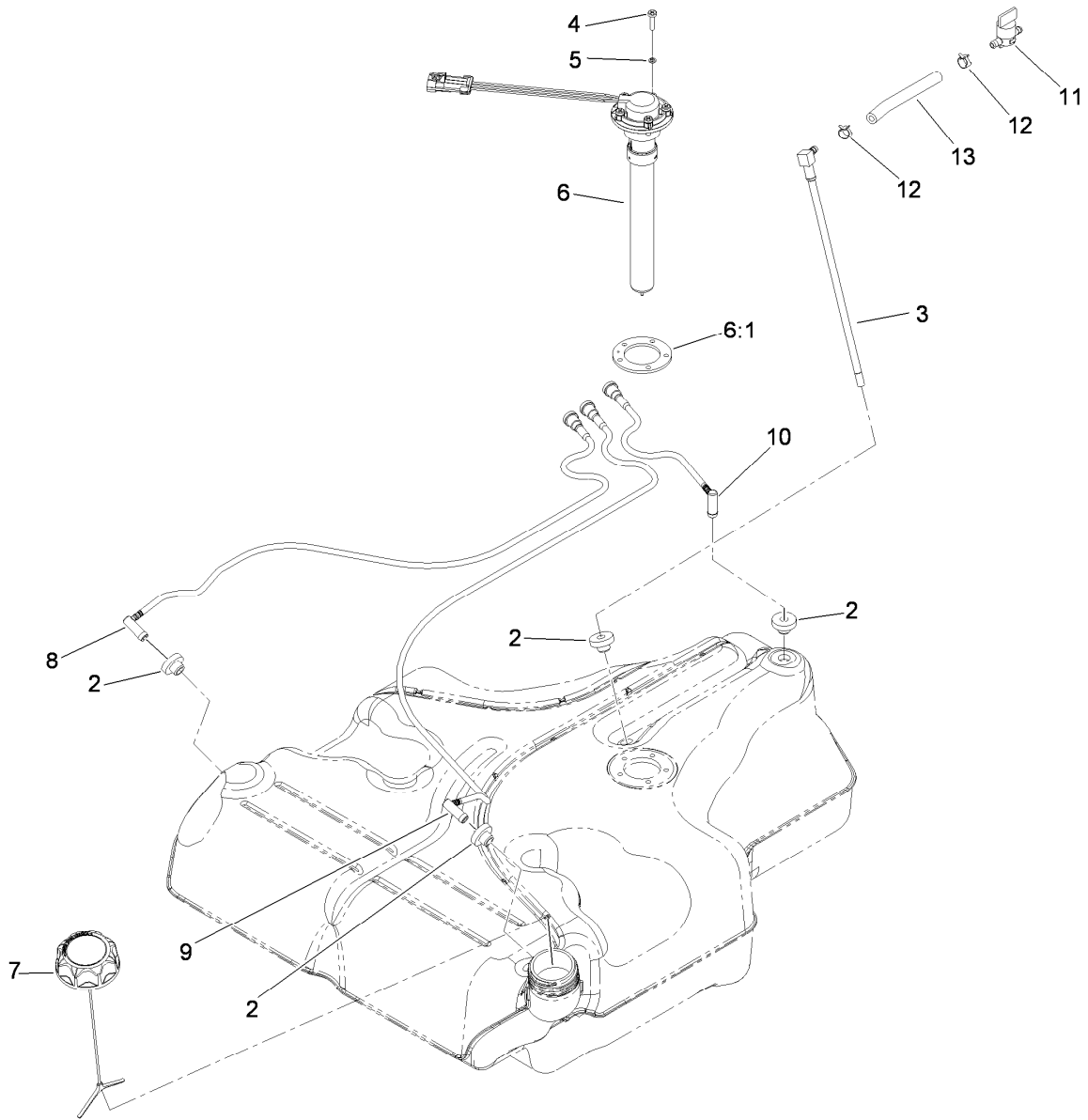

## Fuel Tank Assembly No. 116-3979

Ref.	Part Number	Qty.	Description
2	46-6560	4	Bushing
3	109-9364	1	Fitting-Fuel (W/Line And Screen)
4	9107944	5	Screw-Pan 10-24 X 3/4
5	3253-17	5	Washer-Lock 3/16
6	116-0003	1	Sender-Fuel Level
6:1	109-9620	1	Gasket-Sender, Fuel
7	116-1704	1	Cap-Fuel, Ratcheting
8	109-9447	1	Tube-Vent, RH
9	109-9448	1	Tube-Vent, LH
10	109-9449	1	Tube-Vent, Rear
11	1-603770	1	Valve-Fuel
12	2412-98	2	Clamp-Hose
13	109-0650	1	Hose-Fuel

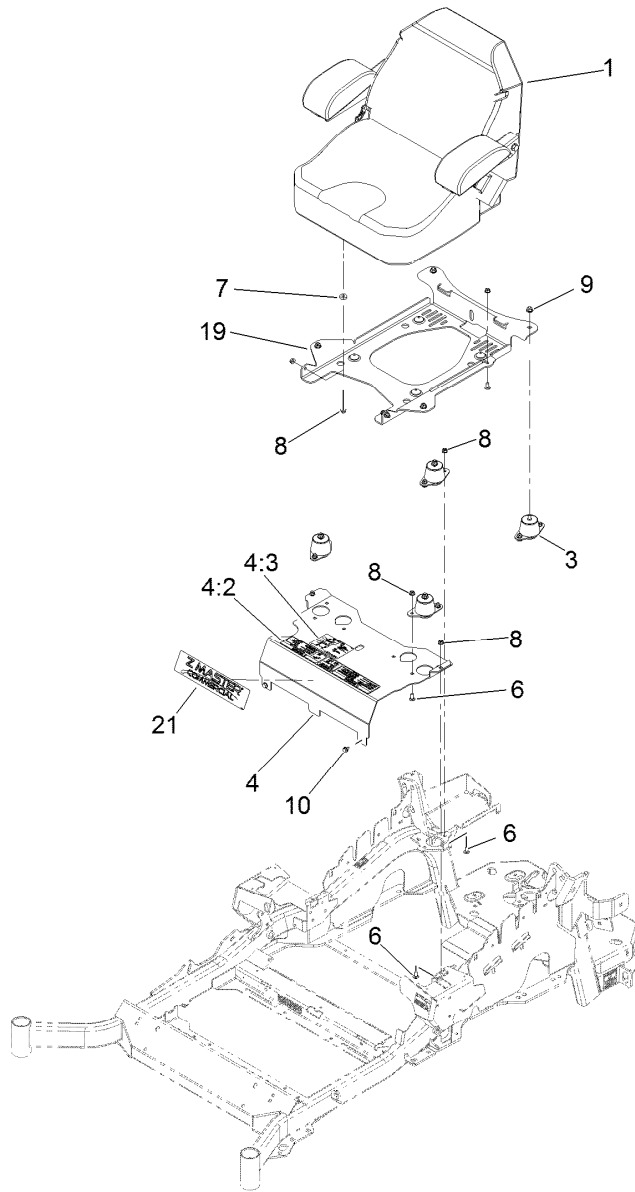

## Seat Mounting Assembly

<i>Ref.</i>	<i>Part Number</i>	<i>Qty.</i>	<i>Description</i>
1	116-0035	1	Seat-Standard
3	109-9034	4	Isolator-Seat
4	116-2323	1	Mount-Seat
4:2	109-7069	1	Decal-Console
4:3	116-0211	1	Decal-Service Aid
6	3230-23	10	Screw-CARR
7	26-4840	4	Spacer-Pin, Mounting
8	104-8300	14	Nut-Flange, NI
9	104-8301	4	Nut-Flange, NI
10	9266934	2	Screw
19	117-0910	1	Seat Base ASM
21	114-5878	1	Decal-Dash

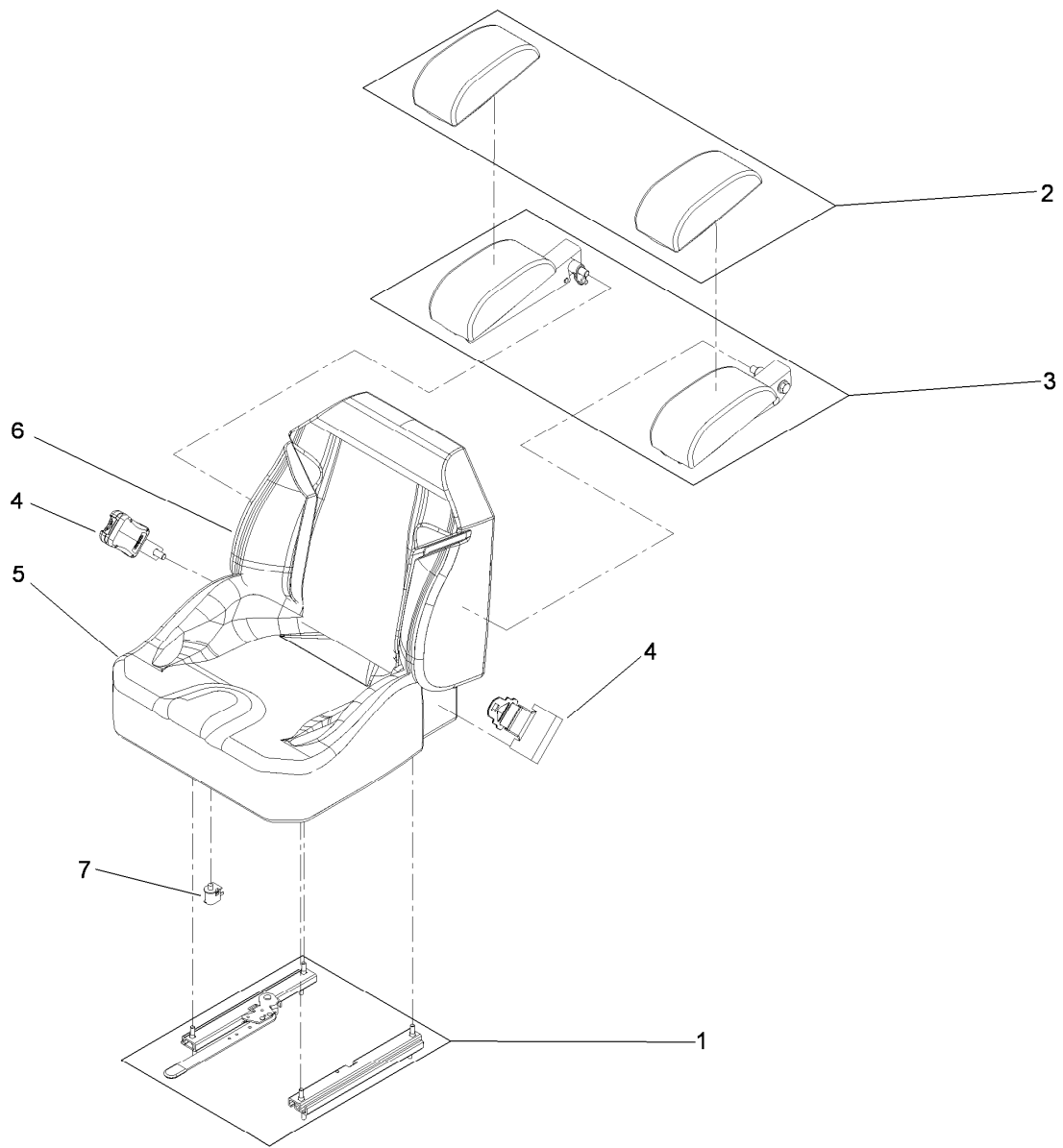

## Seat Assembly No. 116-0035

<i>Ref.</i>	<i>Part Number</i>	<i>Qty.</i>	<i>Description</i>
1	109-9801	1	Seat Track Set
2	109-9802	1	Arm Rest Pad Set
3	109-9803	1	Arm Rest Set
4	109-9805	1	Seat Belt Kit
5	109-9806	1	Cover-Cushion
6	109-9808	1	Cover-Back
7	82-2190	1	Switch-Bail

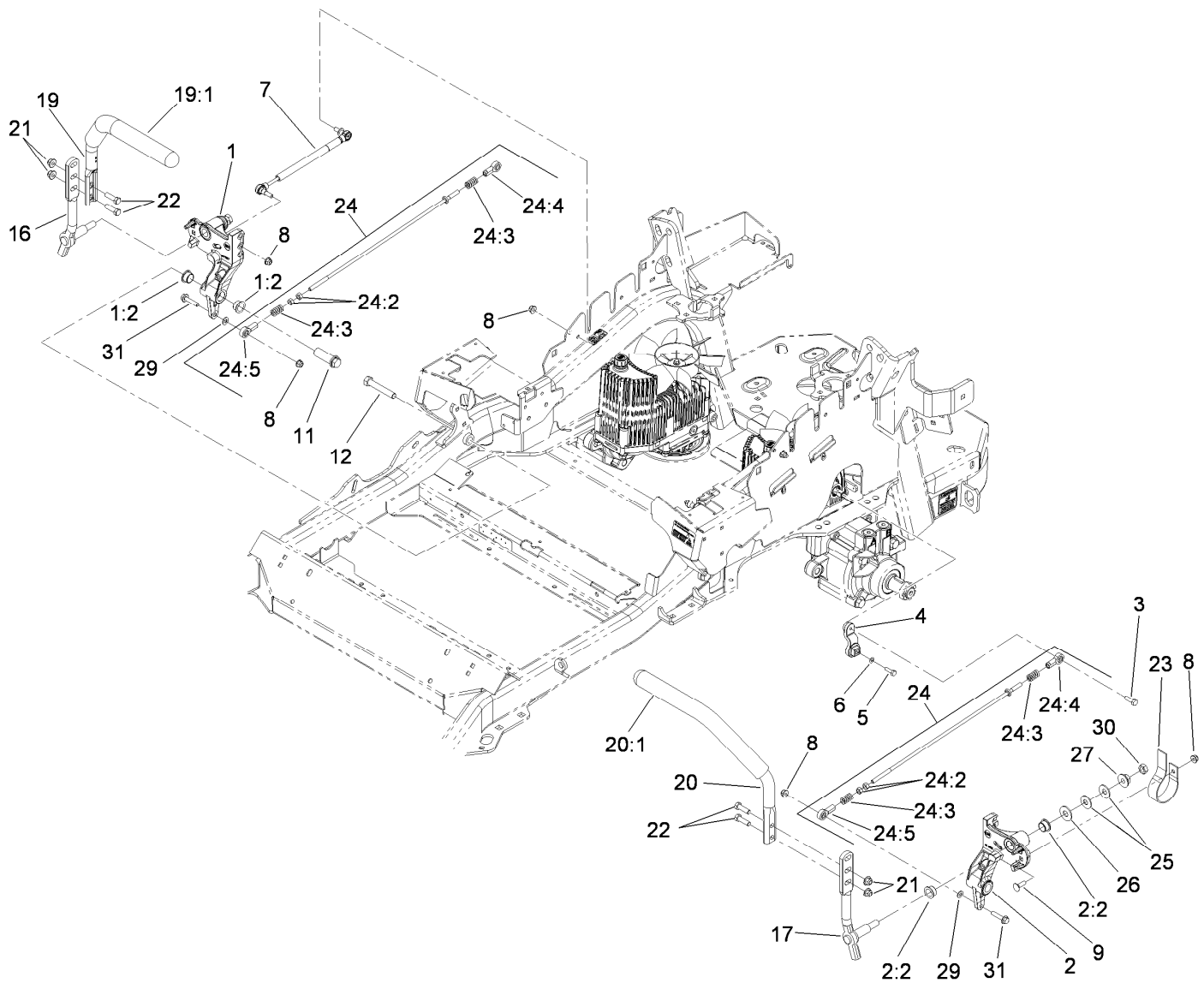

## Motion Control Assembly

Ref.	Part Number	Qty.	Description	Ref.	Part Number	Qty.	Description
1	116-0880	1	RH Motion Control And Bushing ASM	19:1	106-9987	1	Grip-Control, Motion
1:2	109-8054	4	Bushing-Flange	20	109-6592	1	LH Steering Handle ASM
2	116-0881	1	LH Motion Control And Bushing ASM	20:1	106-9987	1	Grip-Control, Motion
2:2	109-8054	4	Bushing-Flange	21	104-8301	4	Nut-Flange, NI
3	116-0648	2	Screw-HH, Thread Locking	22	323-7	4	Screw-HH
4	109-4581	2	Arm-Control, Pump	23	109-5575	2	Spring-Leaf
5	9080046	2	Screw-HH	24	109-8107	2	Pump Linkage Rear ASM
6	1-303435	2	Washer-Spring	24:2	3219-2	2	Nut-Hex
7	116-0027	2	Damper-Control, Motion	24:3	1-323245	2	Spring-Compression
8	104-8300	8	Nut-Flange, NI	24:4	1-633152	1	Balljoint-LH
9	3230-2	2	Bolt-CARR	24:5	1-543017	1	Balljoint-RH
11	109-5891	2	Hub-Threaded	25	109-9505	4	Washer-Spring
12	325-12	2	Screw-HH	26	3256-6	2	Washer-Flat
16	116-0039	1	Lever-Control Motion, RH	27	32128-56	2	Nut-HF
17	116-0040	1	Lever-Control Motion, LH	29	3256-23	2	Washer-Flat
19	109-6591	1	RH Steering Handle ASM	30	3218-5	2	Nut-Jam
				31	115-1794	2	Screw-HHF

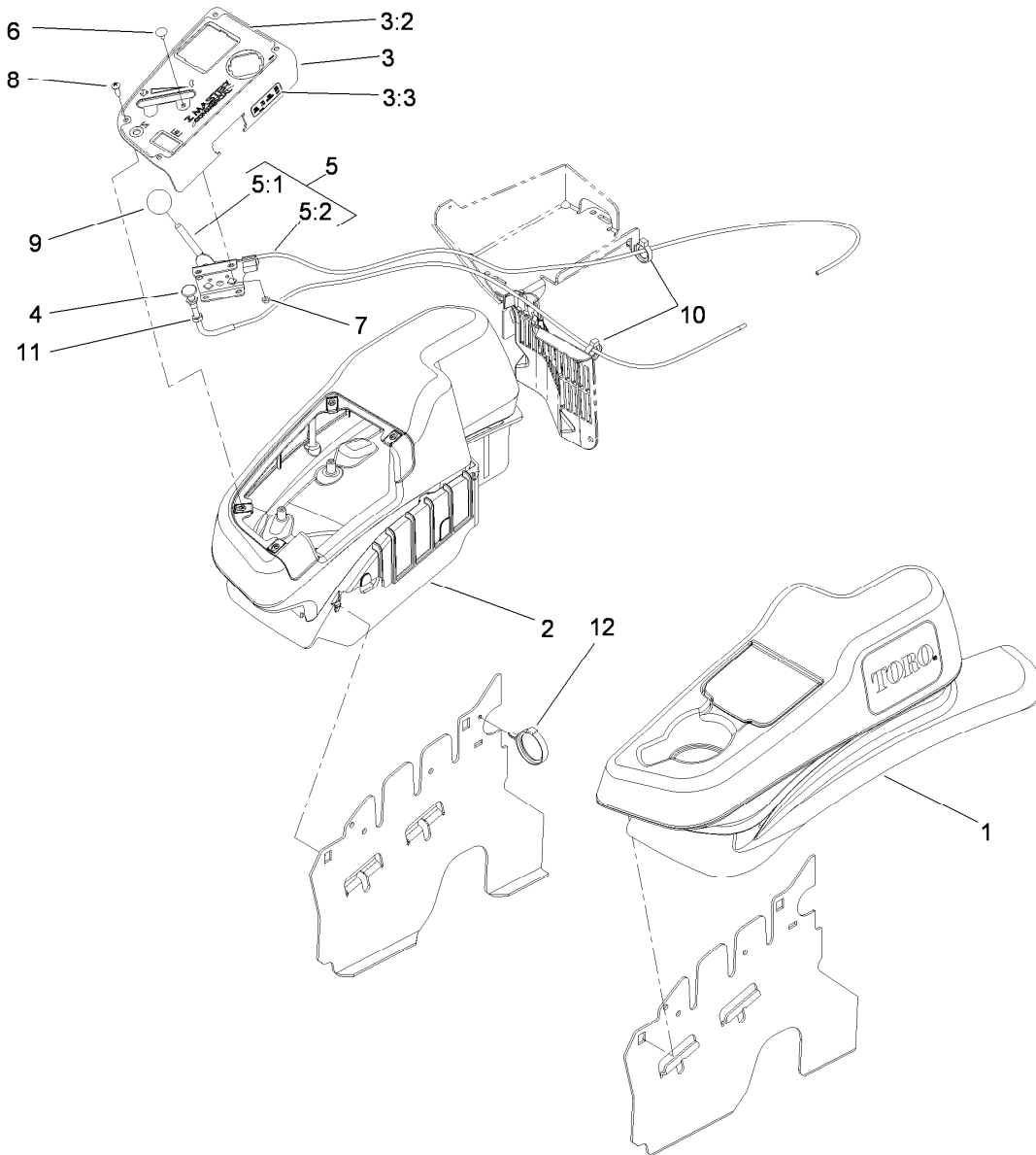

## Fender, Console and Control Assembly

Ref.	Part Number	Qty.	Description
1	115-7403	1	LH Narrow Fender/Console ASM
2	115-7402	1	RH Narrow Fender/Console ASM
3	114-9837	1	Control Panel ASM
3:2	117-0876	1	Decal-Panel, Control
3:3	114-4466	1	Decal-Fuses
4	115-2756	1	Choke Control ASM
5	115-2752	1	Throttle Control ASM

Ref.	Part Number	Qty.	Description
5:1	112-2334	1	Lever-Throttle
5:2	115-3868	1	Cable-Throttle
6	1-807513	2	Bolt-CARR
7	3296-2	2	Nut-Lock, NI
8	32105-15	4	Screw
9	1-603175	1	Knob-Ball
10	105-1853	2	Clamp-Hose
11	3220-3	1	Nut-HJ
12	117-7817	1	Clamp-Harness

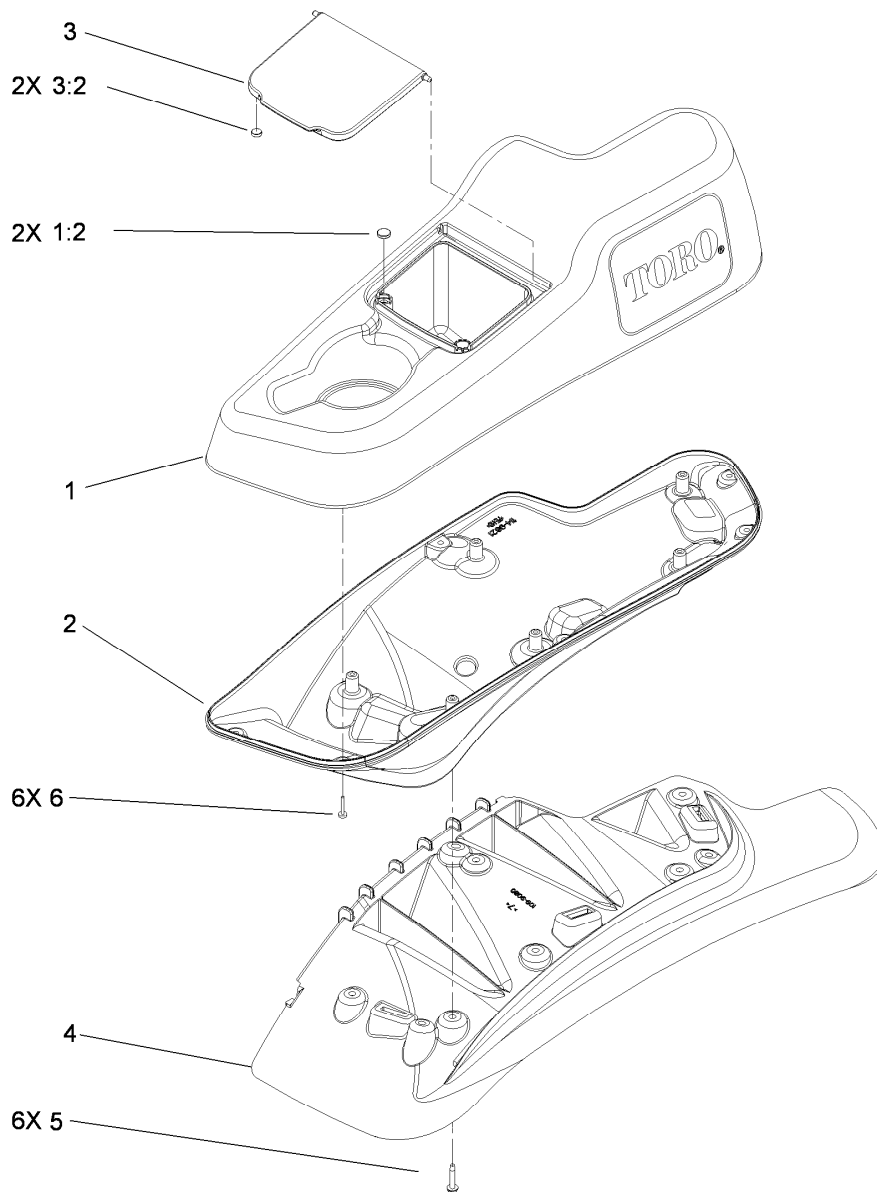

## LH Console Assembly No. 115-7403

Ref.	Part Number	Qty.	Description
1	114-1541	1	LH Console Top ASM
1:2	117-0883	2	Puck
2	114-9821	1	LH Lower Console
3	114-1536	1	Lid ASM
3:2	114-5896	2	Magnet
4	109-9080	1	Fender-LH
5	32144-89	6	Screw-Thread Forming
6	117-0347	6	Screw-Fillister Head

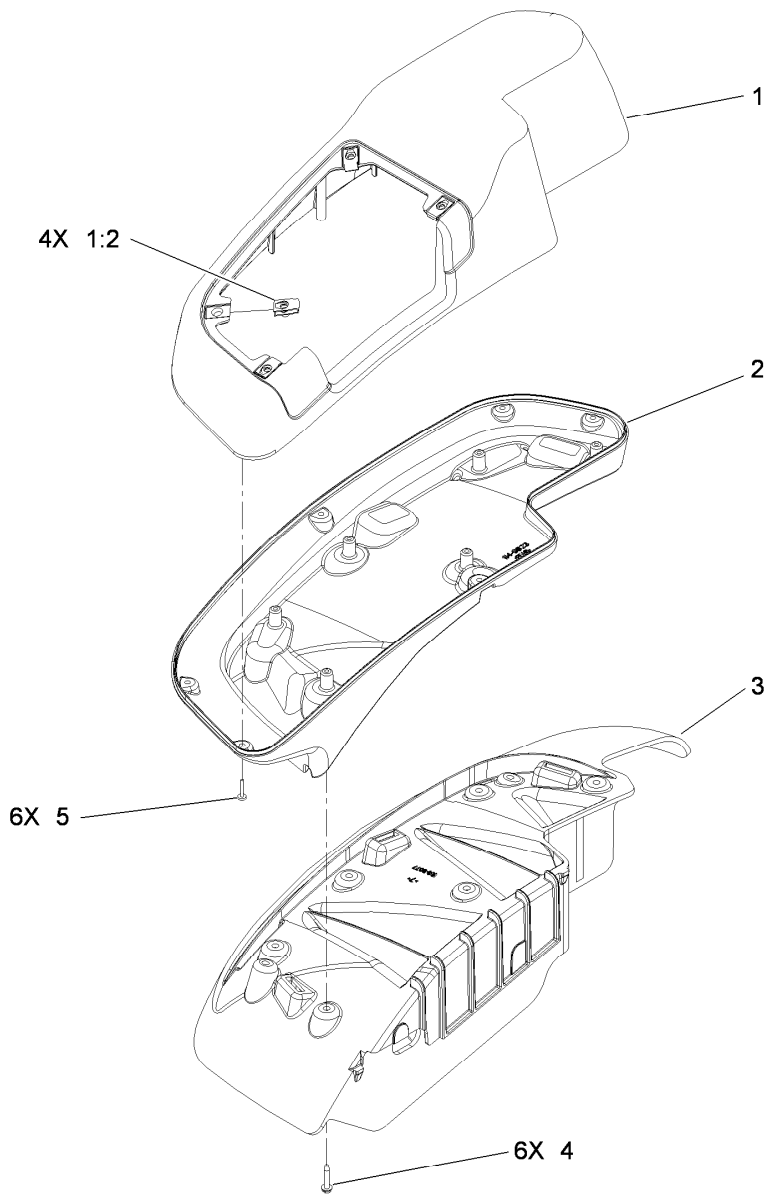

## RH Console Assembly No. 115-7402

<i>Ref.</i>	<i>Part Number</i>	<i>Qty.</i>	<i>Description</i>
1	114-1542	1	RH Console Top ASM
1:2	107069	4	Clip
2	114-9823	1	Console-Narrow, RH
3	109-9077	1	Fender-Narrow, RH
4	32144-89	6	Screw-Thread Forming
5	117-0347	6	Screw-Fillister Head

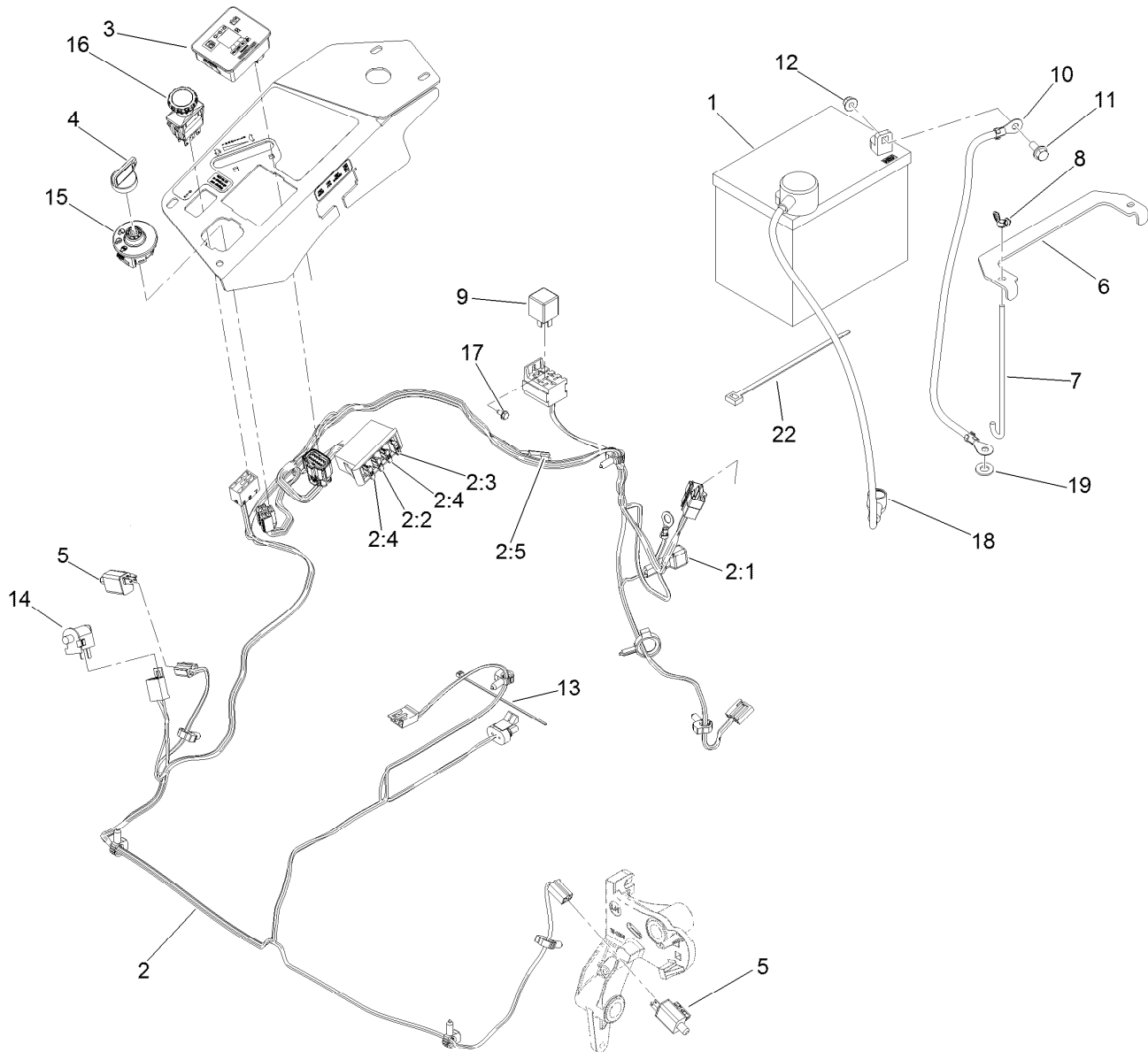

## Electrical System Assembly

<i>Ref.</i>	<i>Part Number</i>	<i>Qty.</i>	<i>Description</i>	<i>Ref.</i>	<i>Part Number</i>	<i>Qty.</i>	<i>Description</i>
1	104-2491	1	Battery	9	1-643275	1	Relay
2	115-2796	1	Harness-Wire, Main	10	114-1218	1	Cable-Battery, Negative
2:1	103-3895	1	Diode-Tvs	11	3234-5	2	Screw-HHF
2:2	218-578	1	Fuse-Blade, 10 Amp	12	104-8300	2	Nut-Flange, NI
2:3	109355	1	Fuse-Blade, 15 Amp	13	1-303287	3	Tie-Cable
2:4	109102	2	Fuse-Blade, 25 Amp	14	82-2190	1	Switch-Bail
2:5	116-0053	1	Cap-Plug	15	117-2221	1	Switch-Ignition
3	117-3882	1	Fuel/Hour Meter ASM	16	116-0124	1	Switch-PTO, 10A
4	63-8360	1	Key-Ignition	17	104-2065	1	Screw-HWH
5	110-6765	2	Switch-Single Pole No	18	115-3864	1	Cable-Battery, Positive
6	116-0042-03	1	Strap-Tie Down, Battery	19	3256-24	1	Washer-Flat
7	1-633651	2	Bolt-Holddown	22	1-303335	1	Tie-Plastic
8	1-543792	2	Wingnut				

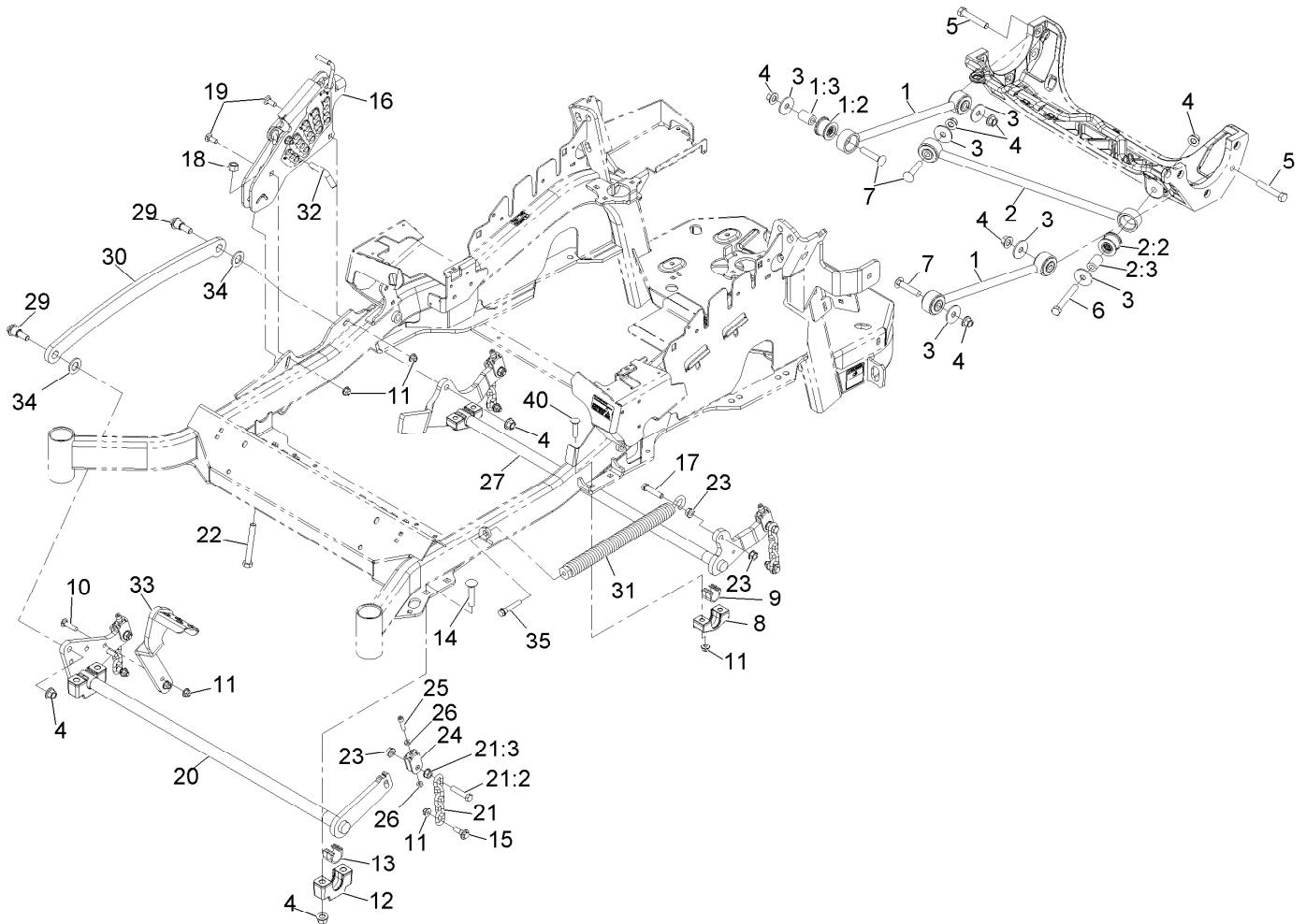

## Deck Lift Assembly

<i>Ref.</i>	<i>Part Number</i>	<i>Qty.</i>	<i>Description</i>	<i>Ref.</i>	<i>Part Number</i>	<i>Qty.</i>	<i>Description</i>
1	109-7952	2	Deck Strut ASM	16	109-7438	1	Height-Of-Cut ASM
1:2	109-5009	2	Bushing-Suspension, Rubber	17	109-9065	1	Screw-HH
1:3	109-5010	2	Spacer	18	3296-23	1	Nut-Lock, NI
2	109-5013	1	Panhard Rod ASM	19	3231-2	2	Screw-CARR
2:2	109-5009	2	Bushing-Suspension, Rubber	20	116-2217-03	1	Cross Shaft Front ASM
2:3	109-5010	2	Spacer	21	116-0756	4	Deck Lift Chain ASM
3	86-1990	6	Washer	21:2	109-9065	1	Screw-HH
4	99-5107	12	Nut-Lock	21:3	32128-37	1	Nut-HF
5	325-12	2	Screw-HH	22	116-0559	1	Bolt-TAP
6	325-17	1	Screw-HH	23	32128-37	6	Nut-HF
7	3233-34	3	Screw-CARR	24	109-9066	4	Yoke-Adjust, Deck
8	116-0818-03	2	Support-Bearing, Cross Shaft Rear	25	3274-18	4	Screw-HSH
9	109-7173	2	Bearing-Cross, Rear Shaft	26	3218-2	8	Nut-Jam
10	3231-4	2	Screw-CARR	27	116-0459-03	1	Lift-Deck, Rear
11	104-8301	12	Nut-Flange, NI	29	116-0780	2	Screw-HHF, Shoulder
12	109-9409	2	Support-Cross Shaft, Bearing Front	30	116-0797-03	1	Link-Lift, Deck
13	109-9410	2	Bearing-Shaft Front, Cross	31	116-0886	1	Extension Spring ASM
14	116-1700	4	Bolt-CARR	32	109-8757	1	Pin-HOC
15	109-9840	4	Screw-Shoulder, HHF	33	116-1919-01	1	Lever-Foot
				34	3256-28	2	Washer-Flat
				35	92-7674	1	Bolt-Shoulder
				40	3231-5	4	Screw-CARR

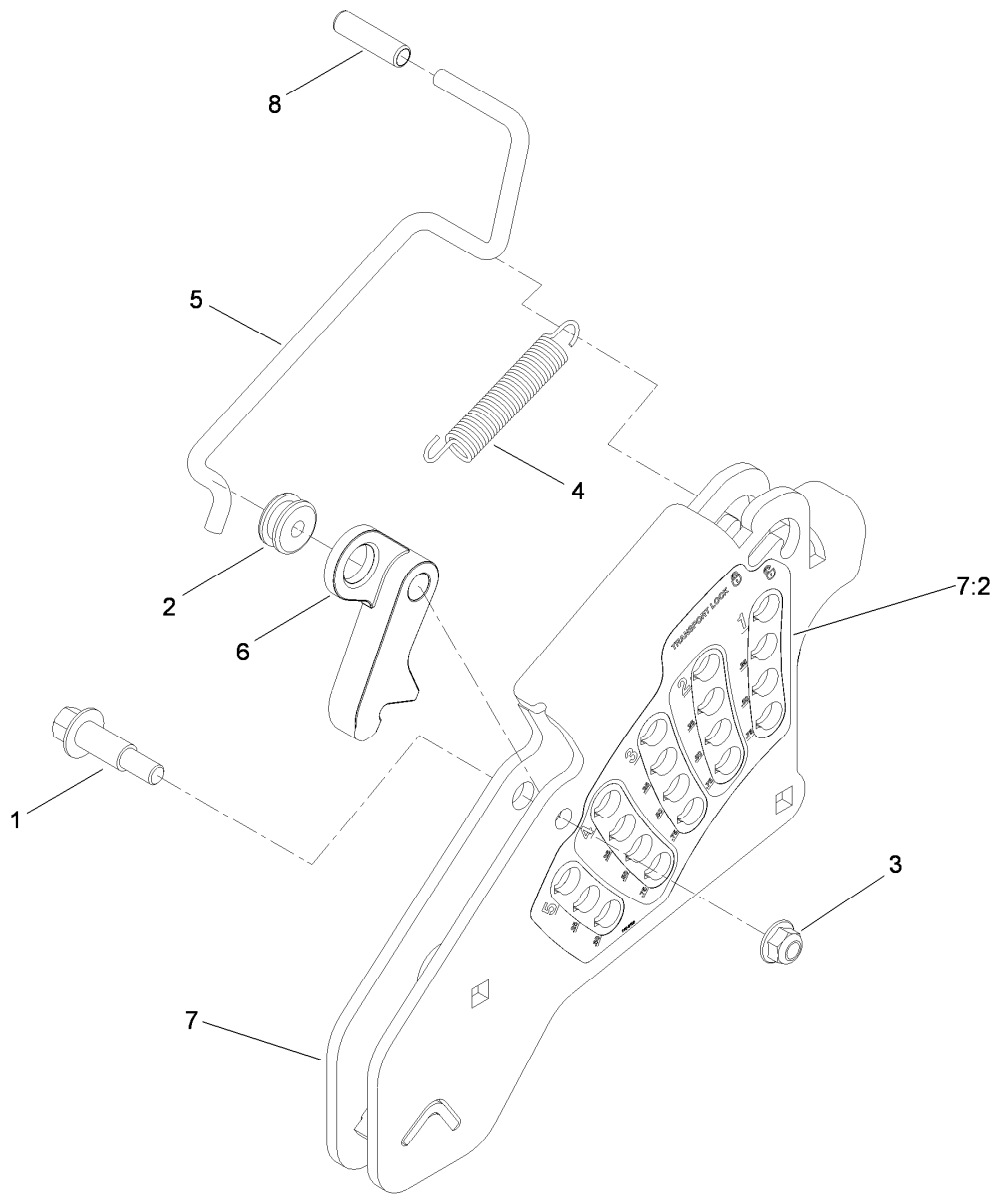

## Height-of-Cut Assembly No. 109-7438

<i>Ref.</i>	<i>Part Number</i>	<i>Qty.</i>	<i>Description</i>
1	62-1330	1	Bolt-Shoulder
2	109-7130	1	Grommet
3	104-8301	1	Nut-Flange, NI
4	109-7124	1	Spring-Extension
5	109-7128	1	Rod-Lock, Transport
6	116-0118	1	Pawl-Transport, HOC
7	109-7335	1	HOC Plate ASM
7:2	116-0752	1	Decal-HOC
8	109-8250	1	Grip-Lever

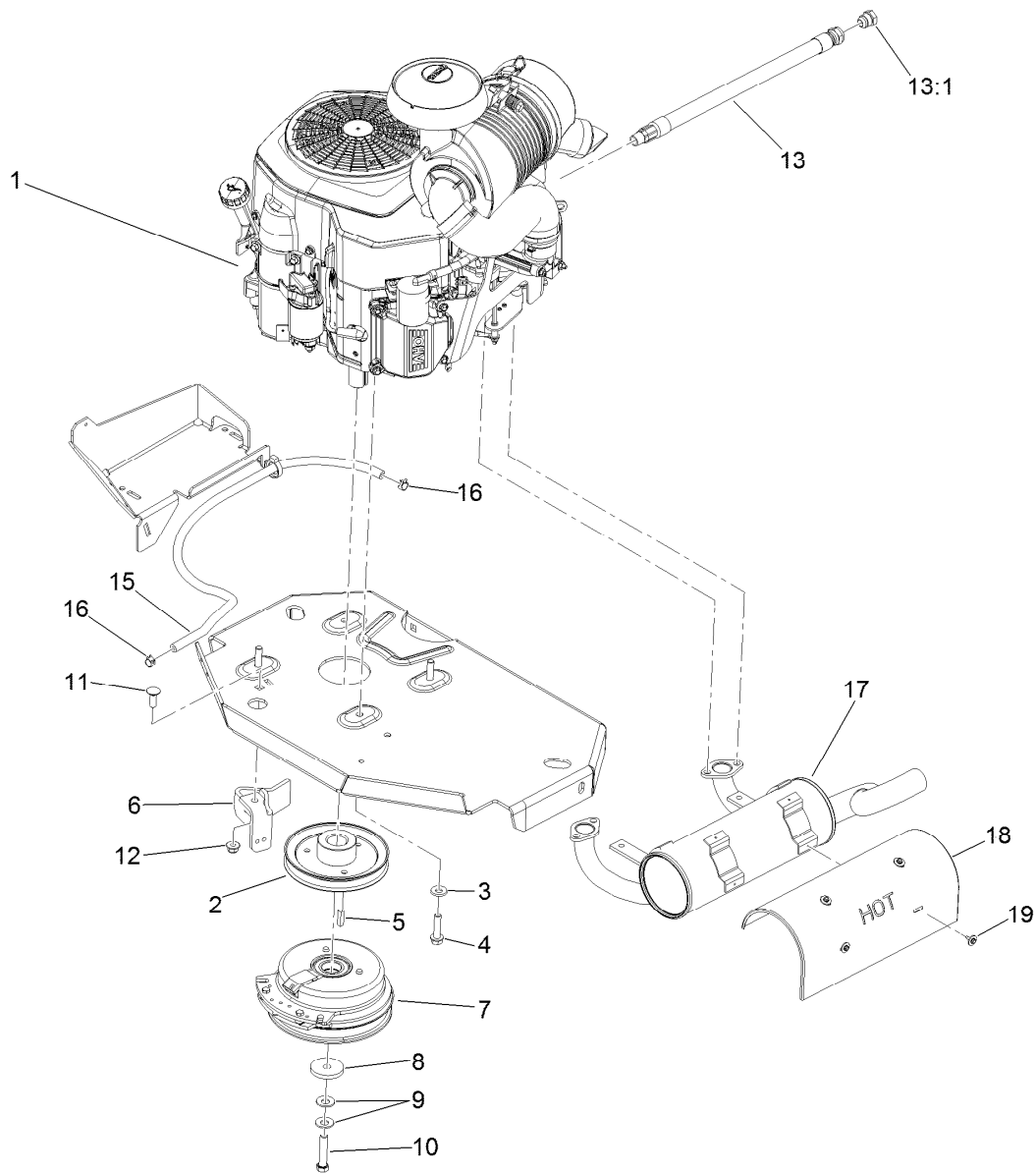

## Engine, Clutch and Muffler Assembly

Ref.	Part Number	Qty.	Description
1		1	Engine-Kohler, Cv680 ● ■
2	109-9905	1	Sheave
3	98-5975	4	Washer-Belleville
4	32144-102	4	Screw-HWH
5	1-807259	1	Key
6	116-2612-01	1	Clutch-Anchor
7	116-1620	1	Clutch Kit
8	109-6919	1	Washer-Clutch
9	1-603610	2	Washer-Spring
10	109-9762	1	Screw-HH W/Loctite

Ref.	Part Number	Qty.	Description
11	3231-22	1	Screw-CARR
12	104-8301	1	Nut-Flange, NI
13	116-0013	1	Oil Drain Hose ASM
13:1	109-1012	1	Plug
15	109-0286	1	Hose-Fuel
16	2412-98	2	Clamp
17	117-6151	1	Muffler
18	117-6152	1	Guard-Muffler
19	116-1103	4	Screw-HH, Thread Forming

● Not serviced separately

■ Obtain parts from [www.kohlerplus.com](http://www.kohlerplus.com)

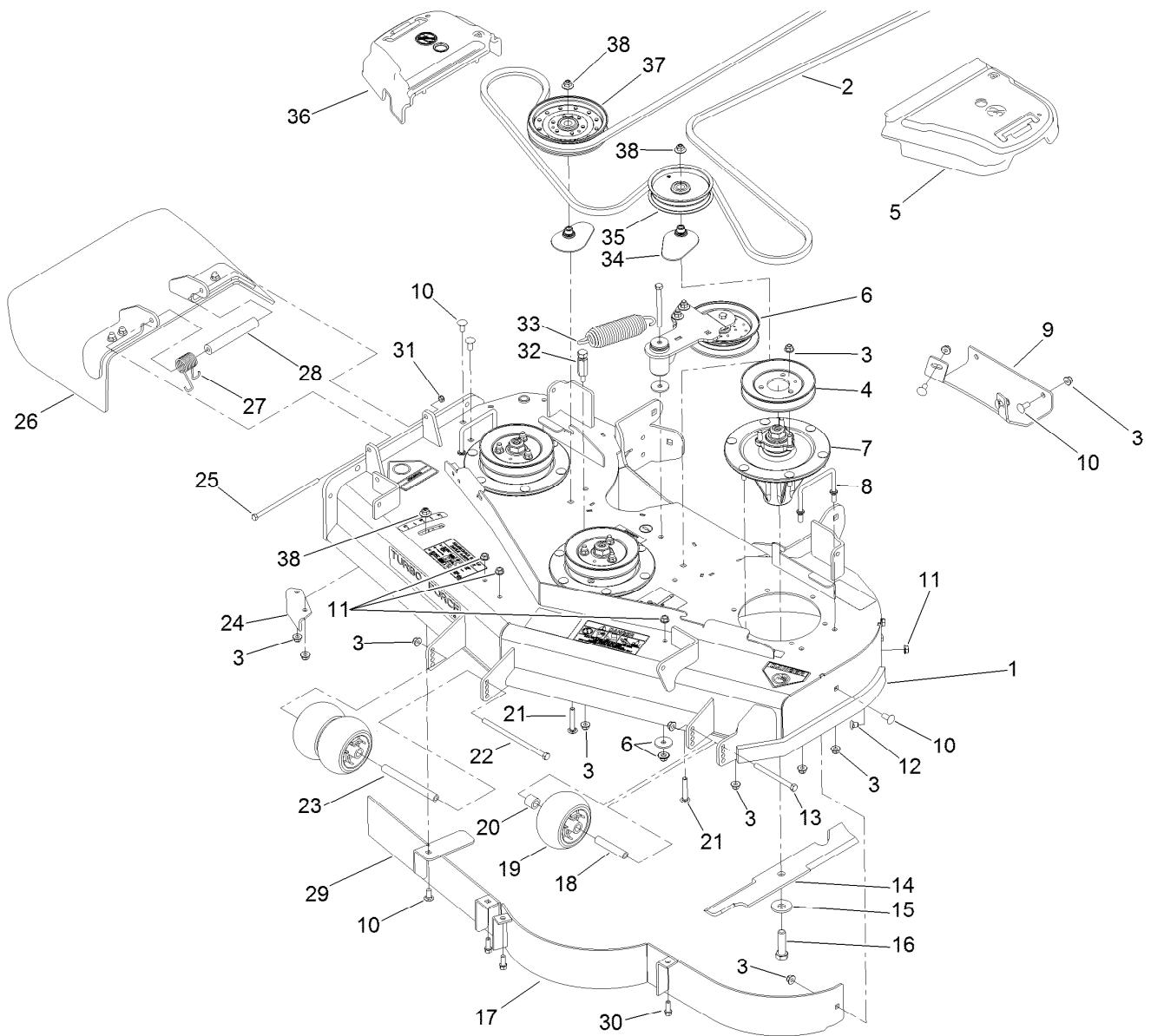

## Deck Assembly

Ref.	Part Number	Qty.	Description	Ref.	Part Number	Qty.	Description
1	114-5805	1	Deck Decal ASM	20	98-7913	1	Tube-Spacer
2	115-7407	1	Belt-V	21	3231-40	2	Bolt-CARR
3	104-8301	41	Nut-Flange, NI	22	108-5388	1	Screw-HH
4	115-7440	3	Pulley	23	98-5967	1	Spacer-Wheel
5	109-6936	1	Cover-Belt, LH	24	107-8541-01	1	Baffle-Discharge
6		1	Idler Arm ASM ●	25	322-50	1	Screw-HH
7	119-8560	3	Spindle ASM	26	108-7770	1	Rubber Deflector ASM
8	109-6982	2	Wireform-Cover	27	108-4052	1	Spring-Torsion
9	112-4230-01	1	Plate-Skid	28	105-4622	1	Spacer
10	3231-27	8	Screw-CARR	29	115-7455-01	1	Baffle ASM
11	3290-357	6	Nut-HHF, Whiz	30	92-1624	3	Screw-HWH
12	108-5387	3	Screw-CARR	31	3296-47	1	Nut-Lock, NI
13	323-23	1	Screw-HH	32	114-5867	1	Anchor-Spring, Tall
14	107-3192-03	3	Blade-16.5 Inch (High Flow)	33	116-0133	1	Extension-Spring
15	103-0865	3	Washer-Blade Bolt, Heavy	34	109-2872	2	Spacer-Pulley
16	51-4060	3	Screw-Blade	35	1-613098	1	Pulley-Idler
17	114-5862-01	1	Baffle ASM	36	109-6935	1	Cover-Belt, RH
18	98-7912	1	Tube-Spacer	37	114-5895	1	Pulley-Idler, Flat
19	1-603299	3	Roller-Scalp, Anti	38	109-6658	3	Nut-Flange, NI

● Not serviced separately

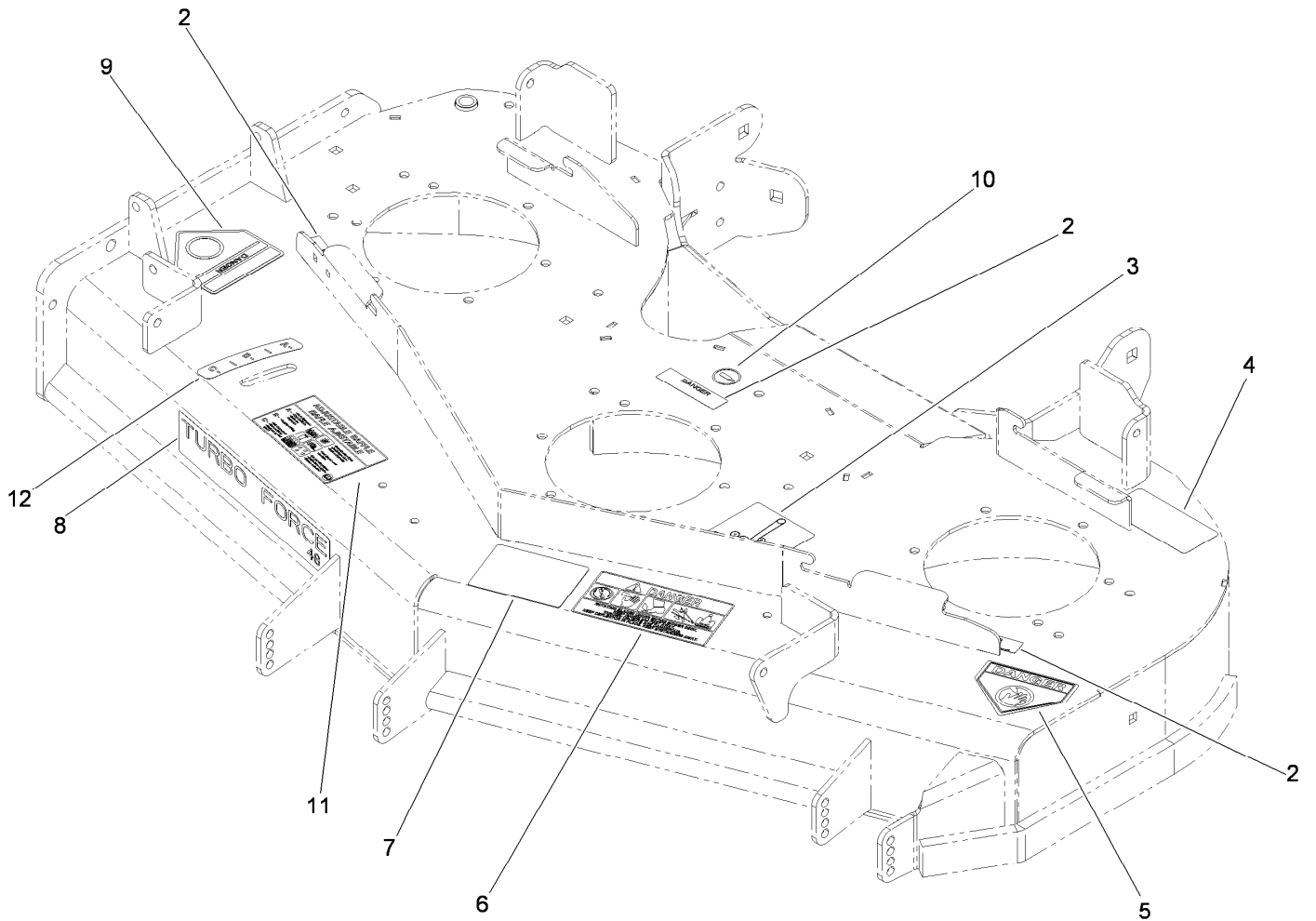

## Deck Decal Assembly No. 114-5805

<i>Ref.</i>	<i>Part Number</i>	<i>Qty.</i>	<i>Description</i>
2	98-5954	3	Decal-Cover, Missing
3	115-7445	1	Decal-Routing, Deck Belt
4	68-8340	1	Decal-Torque
5	1-403005	1	Decal-Danger
6	66-1340	1	Decal-Danger, Thrown Object
7	105-7798	1	Decal-Scalp, Anti
8	107-1690	1	Decal
9	54-9220	1	Decal-Danger
10	58-6520	1	Decal-Grease
11	110-2068	1	Decal-Adjustment, Baffle
12	110-2067	1	Decal-Setting, Baffle

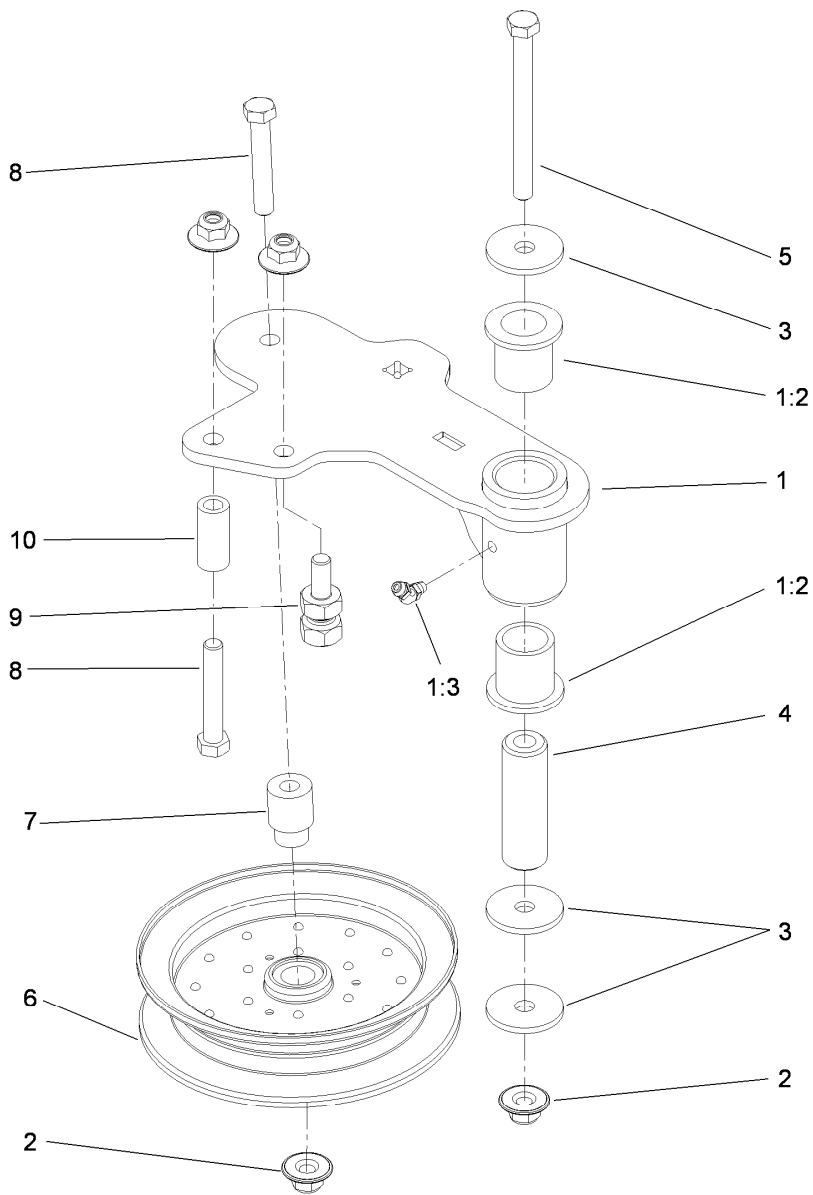

## Idler Assembly

<i>Ref.</i>	<i>Part Number</i>	<i>Qty.</i>	<i>Description</i>
1	114-5870	1	Idler Arm ASM
1:2	1-303514	2	Bearing-Flanged
1:3	1481	1	Fitting-Grease
2	109-6658	4	Nut-Flange, NI
3	1-213069	3	Washer
4	114-5848	1	Spacer-Plain
5	98-5961	1	Screw-HH
6	103-8743	1	Pulley-Idler, Flanged
7	112-4212	1	Mount-Pulley
8	323-11	2	Screw-HH
9	114-5866	1	Anchor-Spring, Short
10	104-0151	1	Spacer

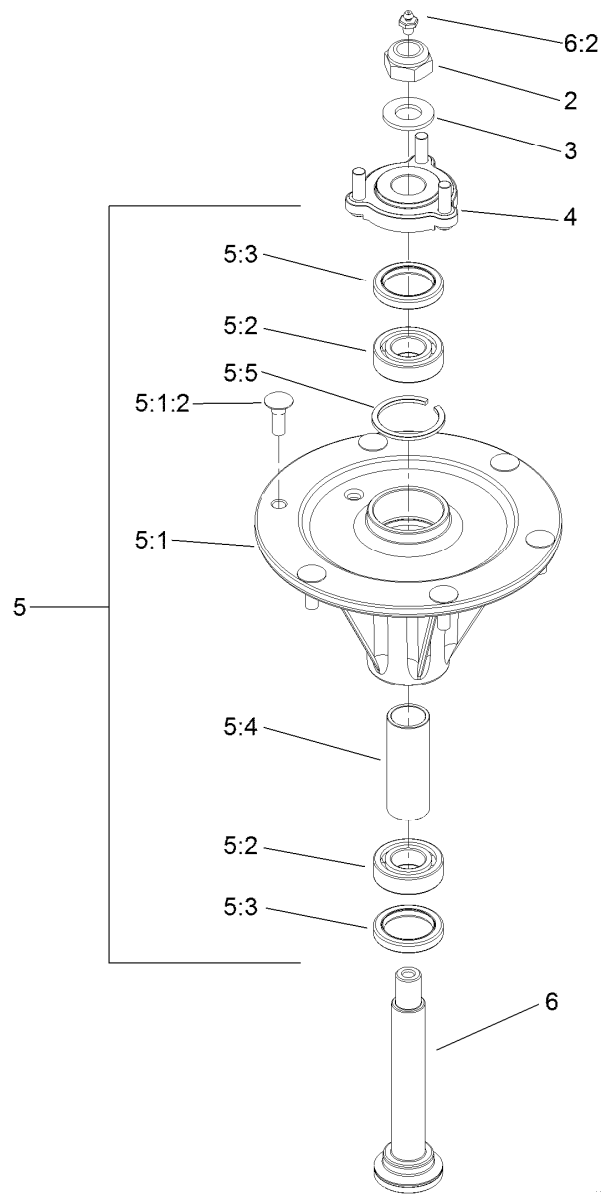

## Spindle Assembly No. 119-8560

Ref.	Part Number	Qty.	Description
2	3296-67	1	Nut-Lock, NI
3	92-5836	1	Washer
4	117-6172	1	Spindle Hub ASM
5		1	Spindle Housing ASM ●
5:1		1	Spindle Housing And Studs ASM ●
5:1:2	114-8195	6	Bolt-Ribbed Neck
5:2	119-8558	2	Bearing 6205 Noseal (Peer)
5:3	253-133	2	Seal-Oil
5:4	117-6184	1	Spacer
5:5	114-8161	1	Ring-Snap
6	119-8527	1	Spindle Shaft And Zerk ASM
6:2	302-2	1	Fitting-Grease

● Not serviced separately

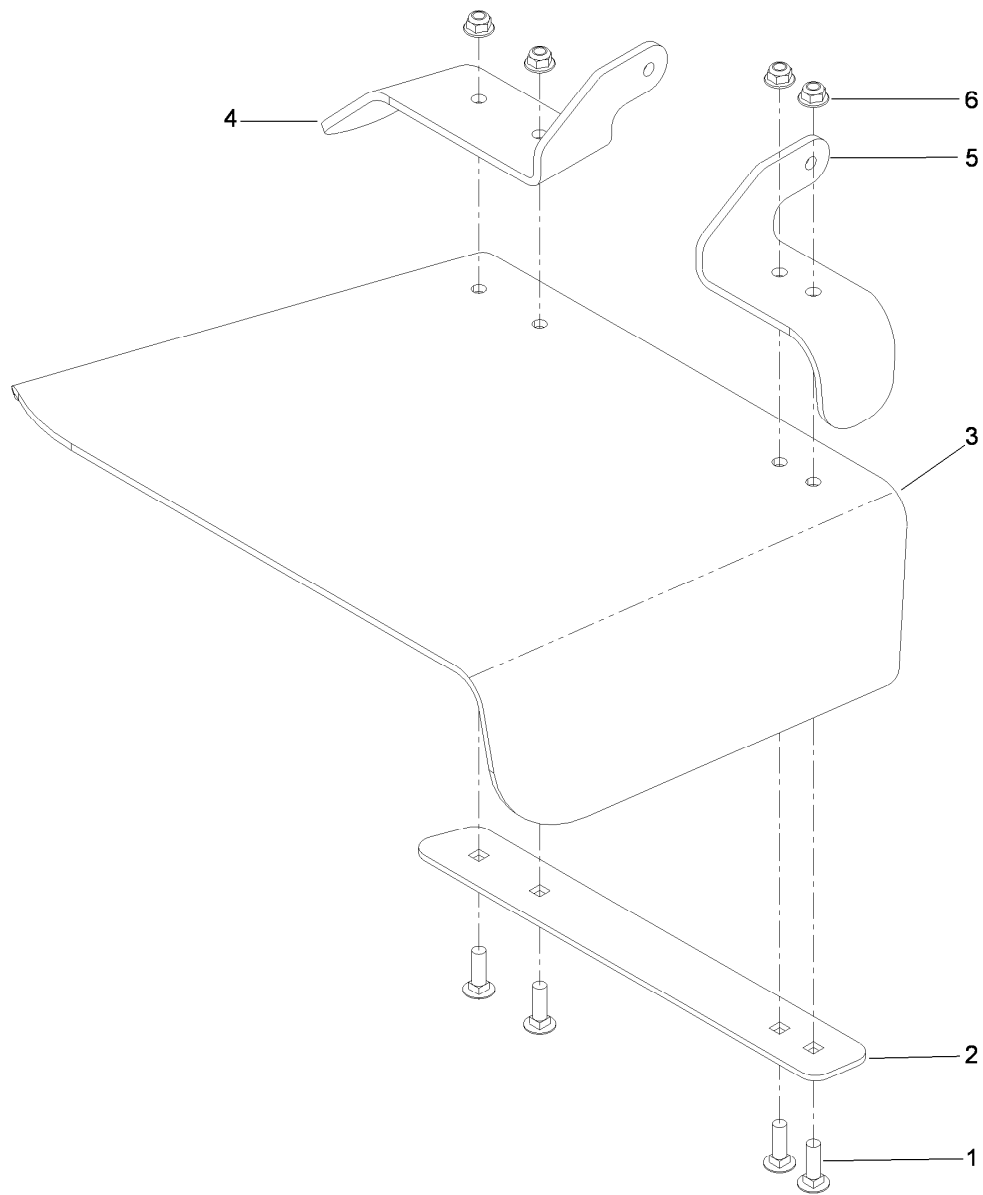

## Rubber Deflector Assembly No. 108-7770

<i>Ref.</i>	<i>Part Number</i>	<i>Qty.</i>	<i>Description</i>
1	3231-25	4	Screw-CARR
2	106-3248-03	1	Strap-Discharge
3	108-5029	1	Deflector-Rubber
4	108-7767-03	1	Bracket-Hinge, Rear
5	108-7766-03	1	Bracket-Hinge, Front
6	104-8301	4	Nut-Flange, NI

# Attachments and Accessories

## For 74901 Z Master G3 Riding Mower with 48in TURBO FORCE Side Discharge Mower

<b>Product Name</b>	<b>Model/Part</b>
Standard High Lift Blade .....	107-3192-03
Blade-Low Flow, 16.5 inch .....	107-3193-03
Blade-Mid Flow, 16.5 inch.....	107-3194-03
Blade-Atomic, 16.5 inch.....	107-3195-03
Blade-Recycling, 16.5 inch .....	107-3196-03
Hitch Kit .....	109-9487
Blade-Hi Flow, 16.5 inch (6 Pack) .....	110-0414
Blade-Lo Flow, 16.5 inch (6 Pack) .....	110-0415
Blade-Recycler, 16.5 inch (6 Pack).....	110-0416
Blade-Atomic, 16.5 inch (6 Pack).....	110-0417
Blade-Mid Flow, 16.5 inch (6 Pack).....	110-0418
Hypr-Oil 500 (quart) .....	114-4713
Hypr-Oil 500 (gallon).....	114-4714
Hypr-Oil 500-5 (5 gallon).....	114-4715
Bimini Folding Shade Assembly .....	115-4510
Recycler Kit .....	115-7466
Roller Striper Kit.....	115-7470
Light Kit.....	116-1154
Z Stand Kit.....	117-0350
Operator-Controlled Discharge Chute Kit .....	117-3600
Deluxe Suspension Seat Kit .....	117-6174
Toro Deluxe Rider Cover.....	490-7319
Spark Arrestor Screen .....	75-6880
Blower and Drive Kit .....	78551
E-Z Vac Twin Bagging System.....	78562
E-Z Vac DFS Collection System .....	78566
Filter Minder Gauge .....	99-4664
Trash Holder Kit.....	TC26

**Notes:**



**Count on it.**