



Electric Hose Reel Kit

Multi-Pro® 5800 Turf Sprayer

Model No. 41613—Serial No. 311000001 and Up

Installation Instructions

The Electric Hose Reel Kit is a dedicated attachment for a turf spray application vehicle and is intended to be used by professional, hired operators in commercial applications. It is primarily designed for spraying on well-maintained lawns in parks, golf courses, sports fields, and on commercial grounds.

This product complies with all relevant European directives, for details please see the separate product specific Declaration of Conformity (DOC) sheet.

Note: If installing kit model numbers 41604 Pro Control XP Spray Kit, 41612 Eductor Kit, 41613 Electric Hose Reel Kit, and 41614 Tank Rinse Kit, it is advisable to assemble them into the manifold valve assembly at the same time.

Read this manual carefully to learn how to operate and maintain your product properly. The information in this manual can help you and others avoid injury and product damage. Although Toro designs and produces safe products, you are responsible for operating the product properly and safely.

You may contact Toro directly at www.Toro.com for product and accessory information, help finding a dealer, or to register your product.

Whenever you need service, genuine Toro parts, or additional information, contact an Authorized Service Dealer or Toro Customer Service and have the model and serial numbers of your product ready. Figure 1 illustrates the location of the model and serial numbers on the product.

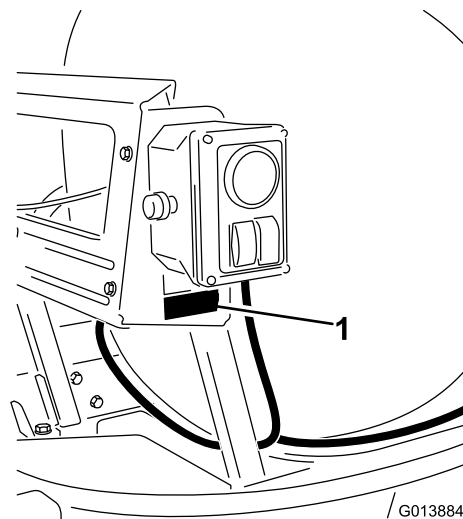

Figure 1

1. Model and serial number plate

<p>Model No. _____</p> <p>Serial No. _____</p>
--

Safety

This manual identifies potential hazards and has safety messages identified by the safety alert symbol (Figure 2), which signals a hazard that may cause serious injury or death if you do not follow the recommended precautions.



Figure 2

1. Safety alert symbol

This manual uses 2 other words to highlight information.

Important calls attention to special mechanical information and **Note** emphasizes general information worthy of special attention.

Read also the safety and operation instructions in the vehicle *Operator's Manual*.

- Do not aim the hand sprayer at any person or animal. Fluids under high pressure can penetrate skin and cause severe injury, possibly resulting in amputation

or death. Hot liquids and chemicals can also cause burns or injury. If any part of the body comes in contact with the spray stream, immediately consult a physician familiar with injected fluid injuries.

- Do not place your hand or any other part of you body in front of the spray nozzle.
- Do not leave the equipment under pressure when you are not present.
- Do not use the hand sprayer if the hose, trigger lock, nozzle, or any other part is damaged or missing.
- Do not use the hand sprayer if there are any leaks in any hoses, fittings, or other components.
- Do not spray near power lines.
- Do not drive while spraying with a hand sprayer.
- Wear rubber gloves, safety goggles, and a full body protective suit when spraying chemicals with the hand sprayer.
- Lightning can cause severe injury or death. If lightning is seen or thunder is heard in the area, do not operate the machine; seek shelter.

Safety and Instructional Decals



Safety decals and instructions are easily visible to the operator and are located near any area of potential danger. Replace any decal that is damaged or lost.

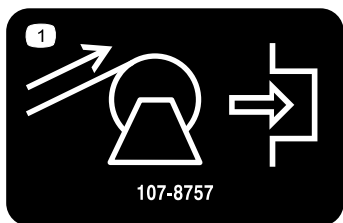

107-8757

1. Hose reel rewind; push to engage.

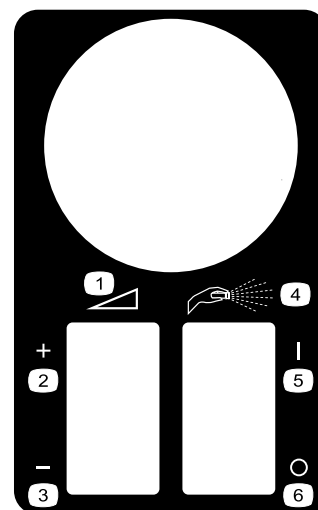

119-4878

1. Continuous variable setting
2. Increase
3. Decrease
4. Hand spray
5. On
6. Off



120-0618

1. Warning—read the *Operator's Manual*.
 2. Crushing hazard of hand, rollers—warning, hose reel self winds; stay away from moving parts, keep all guards and shields in place.
-

Installation

Loose Parts

Use the chart below to verify that all parts have been shipped.

Procedure	Description	Qty.	Use
1	Hose reel valve assembly	4	Install the valve assembly.
	Bolt (M8 X 260 mm)	2	
2	Control box and bracket assembly	1	Install the control box.
	Bolt (1/4 x 5/8 inch)	3	
	Lock nut (1/4 inch)	3	
	Reducer Fitting	1	
3	Hose reel support	1	Assemble the frame.
	Flange-head bolt (3/8 x 1 inch)	10	
	Flange nut (3/8 inch)	10	
	Hose reel strap	2	
	Hose reel assembly	1	
	Flange-head bolt (5/16 x 1 inch)	1	
	Flange nut (5/16 inch)	1	
Cable tie	10		
4	Hose	1	Install the supply hose.
	Hose clamp	2	
	Straight barb	1	
	Conduit	1	
	Cable ties	2	
5	Plastic tie	4	Install the electrical harness
	Fuse, 50 Amp	1	
	Push in connector	2	
6	Long hose with fitting	1	Connect the spray hose.
	Spray gun	1	
	Hose clamp, small	1	

Note: Determine the left and right sides of the machine from the normal operating position.

Note: Thread sealing tape is used in the installation of this kit.

1

Installing the Valve Assembly

Parts needed for this procedure:

4	Hose reel valve assembly
2	Bolt (M8 X 260 mm)

Procedure

1. Loosen, but do not remove, the bolts securing the boom valve assembly to the mount bracket (Figure 3).

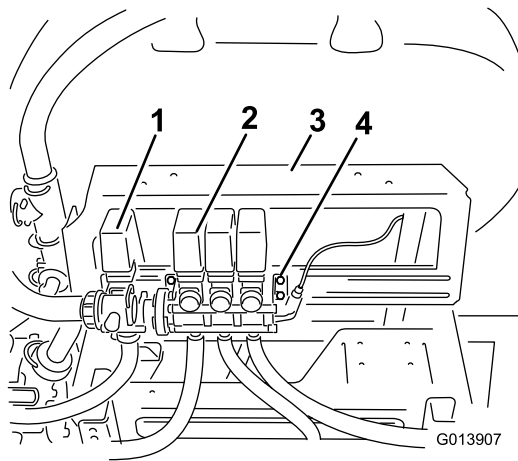

Figure 3

- | | |
|--------------------------|---|
| 1. Agitation valve | 3. Mount bracket |
| 2. Bypass valve assembly | 4. Fasteners, loosen but do not remove. |

2. Loosen the long bolts and fasteners securing the valve assembly (Figure 4). Remove and retain all fasteners. Move the valve assembly to the right.

Note: The valve assembly will no longer be anchored to the machine at this point. It may be desirable to move the entire assembly to a workbench. The boom hoses will need to be removed from the valves to do this.

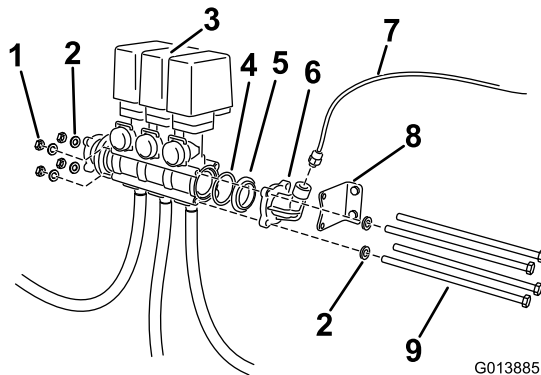

Figure 4

- | | |
|-------------------|--------------------|
| 1. Lock nut | 6. Elbow cap |
| 2. Washer | 7. Red tube |
| 3. Valve assembly | 8. Bracket |
| 4. O-ring | 9. Long bolts, new |
| 5. Adapter | |

3. Remove elbow adapter and gasket (Figure 4). Locate the O-ring seated in the existing valve body. Retain all parts. Move the bracket away from the existing valve assembly.
4. Locate the hose reel valve assembly in loose parts and install in line with the existing valves (Figure 5).

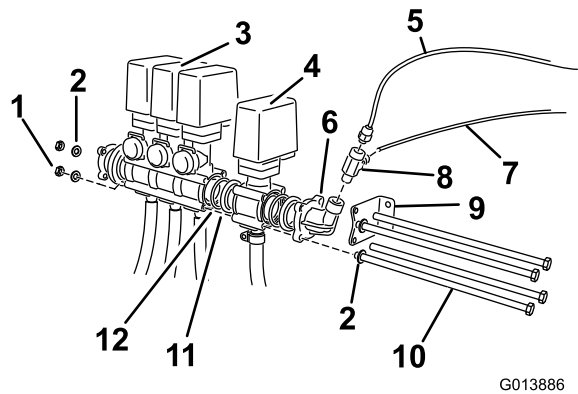

Figure 5

- | | |
|-----------------------|--------------------------------|
| 1. Lock nut | 7. Red tube, to pressure valve |
| 2. Washer | 8. Tee fitting |
| 3. Valve assembly | 9. Bracket |
| 4. Hose reel valve | 10. Long bolts, existing |
| 5. Red tube, existing | 11. Adapter |
| 6. Elbow cap | 12. O-ring |

- A. Verify the existing O-ring is seated in the open end of the boom valve body. If is not at this time, locate it and install now.

- B. Install the gasket previously removed.

- C. Install the hose reel valve assembly.

- D. Install an O-ring from loose parts to the open end of the hose reel valve body.

- E. Install a gasket from loose parts.

- F. Install the elbow adapter removed previously with the bend pointing upward.

5. Move the entire assembly between the brackets on the mounting rail.

6. Reposition the bracket to the end valve assembly at the two holes on the elbow adapter closest to the boom valve mount bracket (Figure 5).

7. Insert two long bolts (M8 X 260 mm) through the mount bracket, at the top and bottom holes in the valve bodies of the hose reel and the boom bypass valves closest to the mounting rail (Figure 5).

8. The bolts should pass through the valve bodies and through the bracket on the opposing side. Secure them with the lock nuts removed previously.

9. Use the remaining two bolts (M8 X 260 mm) with existing washers to secure the valve assemblies at the open holes in the valve bodies (Figure 5)

10. Secure them with the washers and lock nuts removed previously.

11. Torque the long bolts to 24-30 in-lb (272-373 N-cm).

12. Secure the bolts of the mounting bracket to the mounting rail.

13. Install the tee fitting (Figure 5)

- A. Remove the fitting securing the red pressure gauge tube to the elbow adapter.
- B. Locate the tee fitting in loose parts. Wrap the threaded end with the thread tape.
- C. Install the tee fitting to the elbow adapter with the tee facing toward the tank.
- D. Install the fitting removed previously to the open end of the fitting.

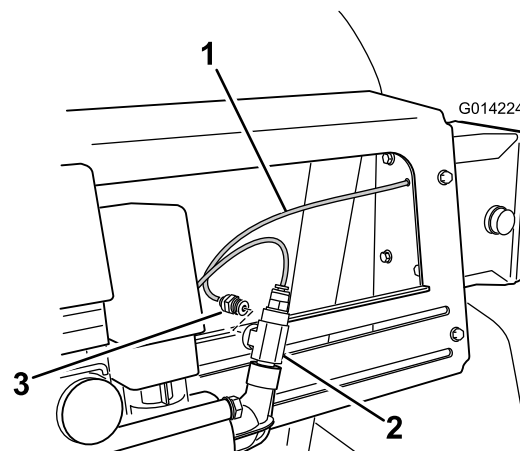

Figure 7

1. Pressure gauge tube from control box
2. Tee fitting
3. Reducer fitting

2

Installing the Control Box

Parts needed for this procedure:

1	Control box and bracket assembly
3	Bolt (1/4 x 5/8 inch)
3	Lock nut (1/4 inch)
1	Reducer Fitting

Procedure

1. Locate the control box and bracket assembly in loose parts.
2. Install the assembly to the mount bracket using 3 bolts (1/4 x 5/8 inch) and 3 lock nuts (1/4 inch) as shown in Figure 6.

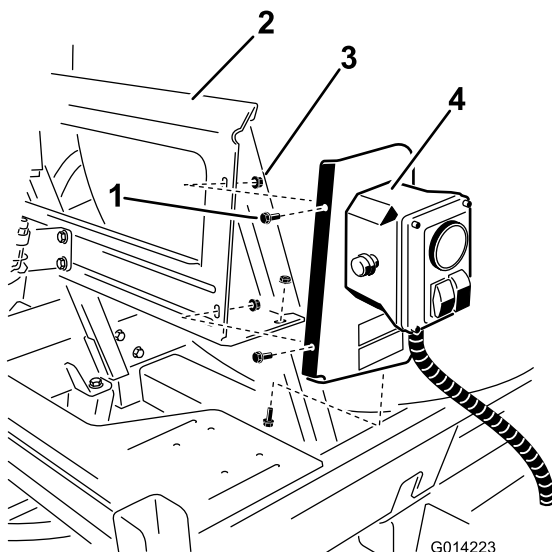

Figure 6

1. Bolt
2. Mount bracket
3. Lock nut
4. Control box and bracket

3. Locate the red, pressure gauge tube coming from the back of the control box and install it to the opening in the tee fitting (Figure 7).

3

Assembling the Frame

Parts needed for this procedure:

1	Hose reel support
10	Flange-head bolt (3/8 x 1 inch)
10	Flange nut (3/8 inch)
2	Hose reel strap
1	Hose reel assembly
1	Flange-head bolt (5/16 x 1 inch)
1	Flange nut (5/16 inch)
10	Cable tie

Procedure

1. Install the hose reel support to the hydraulic reservoir mount (Figure 8) using 2 flange-head bolts (3/8 x 1 inch) and 2 flange nuts (3/8 inch). Do not fully tighten the nuts to allow for adjustment later.

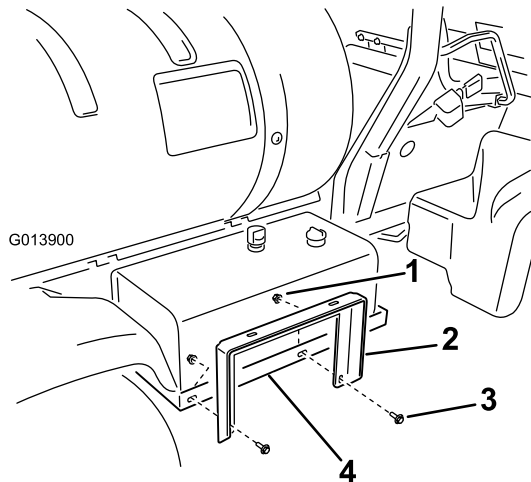

Figure 8

1. Hose reel support
2. Flange-head bolt (3/8 x 1 inch)
3. Lock nut (3/8 inch)
4. Hydraulic reservoir mount

2. Install the ends of the 2 hose reel straps to holes in the tank saddle as shown in Figure 9, using 2 flange-head bolts (3/8 x 1 inch) and 2 flange nuts (3/8 inch).

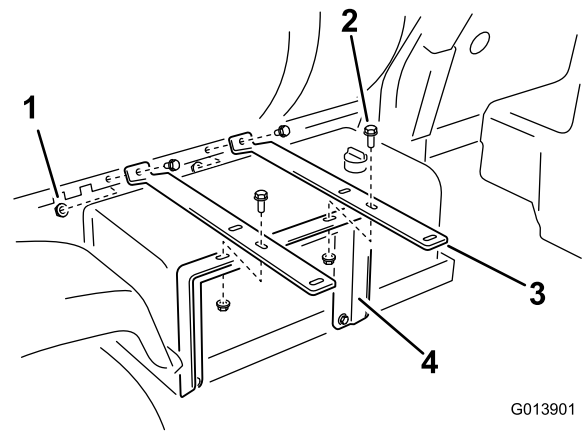

Figure 9

1. Flange-head bolt (3/8 x 1 inch)
2. Lock nut (3/8 inch)
3. Hose reel straps
4. Hose reel support

3. Attach the hose reel support to the hose reel straps (Figure 8) using 2 flange-head bolts (3/8 x 1 inch) and 2 flange nuts (3/8 inch).
4. Level the straps and hose reel support and then tighten all fasteners.
5. Install the hose reel assembly onto the hose reel straps (Figure 10) using 4 flange-head bolts (3/8 x 1 inch) and 4 flange nuts (3/8 inch).

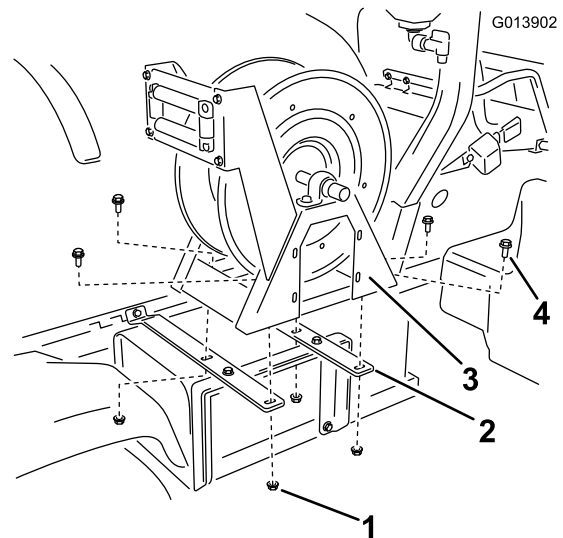

Figure 10

1. Lock nut (3/8 inch)
2. Hose reel straps
3. Hose reel assembly
4. Flange-head bolt (3/8 x 1 inch)

4

Installing the Supply Hose

Parts needed for this procedure:

1	Hose
2	Hose clamp
1	Straight barb
1	Conduit
2	Cable ties

Procedure

1. Locate the reel hose and two hose clamps in loose parts.
2. Install a hose clamp over the open end of the hose.
3. Install the hose end over the right angle barb on the tank sided of the hose reel assembly (Figure 11).

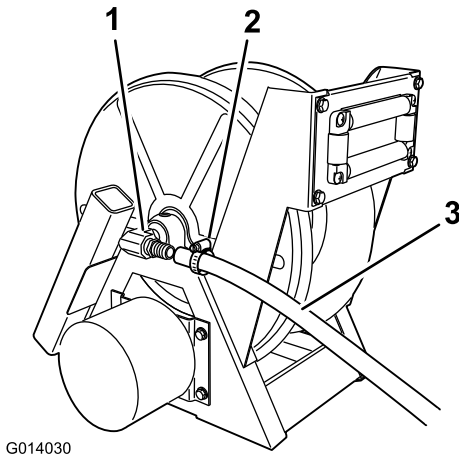

Figure 11

1. Straight barb
2. Hose clamp
3. Hose

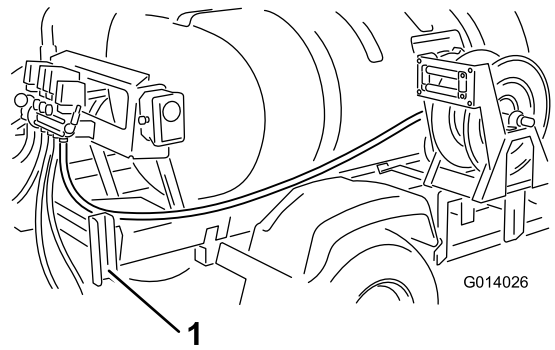

Figure 12

1. Boom support channel

7. Route the hoses around the mount frame and up to the open barb on the hose reel valve installed previously (Figure 12).
8. Slide a hose clamp over the open end of the hose and install the hose over the exposed barb in the valve.

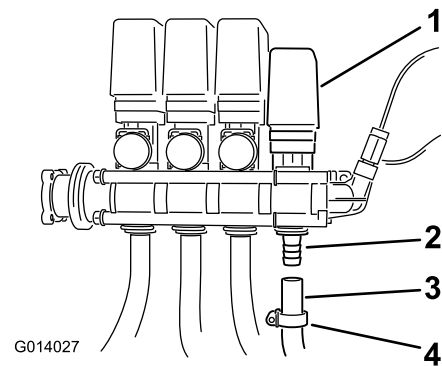

Figure 13

1. Eductor valve
2. Barb
3. Hose
4. Hose clamp

9. Move the hose clamp over the barb and tighten to secure the hose to the valve assembly.

4. Move the hose clamp over the barb and tighten to secure the hose to the reel assembly.
5. Install the conduit over the supply hose at the valve end and secure with 2 cable ties.
6. Route the hose rearward along the tank skid frame, inside of the right rear fender inside the boom support channel (Figure 12).

5

Installing the Electrical Harness

Parts needed for this procedure:

4	Plastic tie
1	Fuse, 50 Amp
2	Push in connector

Procedure

1. Locate the electrical harness coming from the hose reel control box. Route the longer end of the harness with the ring terminals and a fuse connector across the rear of the tank skid and vehicle frame behind the boom actuator bracket (Figure 14). Use a plastic tie to secure the harness to the frame.

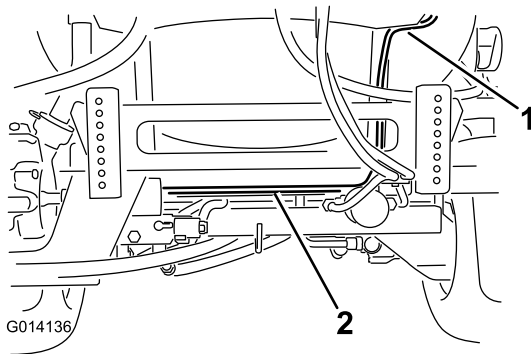

Figure 14

1. Harness from control box
2. Electric hose reel harness, long end

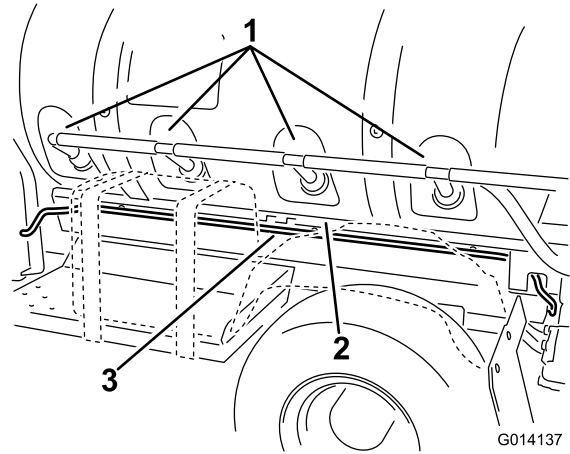

Figure 15

1. Agitation ports
2. Tank skid frame
3. Electric hose reel harness, long end

3. Remove the cover on the battery (Figure 16) and disconnect the negative battery cable.

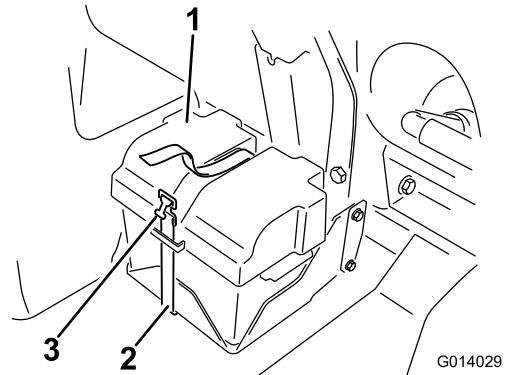

Figure 16

1. Battery cover
2. Strap
3. Buckle

2. Route the harness forward along the tank skid, and below the agitation ports to the battery box (Figure 15). Use three plastic ties to secure the harness to the frame.

4. Attach the positive, red ring terminal on the electrical harness to the fastener on the red batter cable (Figure 17).

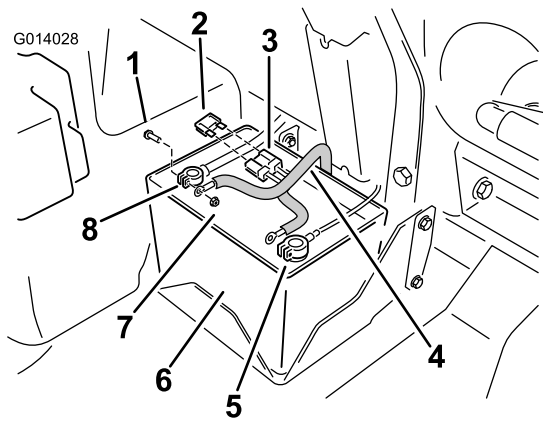

Figure 17

- | | |
|--|---------------------------|
| 1. Bolt, battery post | 5. Negative battery post |
| 2. Fuse, 50 amp | 6. Battery |
| 3. Fuse holder, electric hose reel harness | 7. Lock nut, battery post |
| 4. Electric hose reel harness | 8. Positive battery post |

5. Connect the negative, black ring terminal to the negative battery cable (Figure 17).
6. At the control box, route the remaining harness with the hose reel connector forward on the right side of the machine, between the tank skid and right rear fender (Figure 18). Use 2 push in connectors to secure the harness to the tank skid frame.

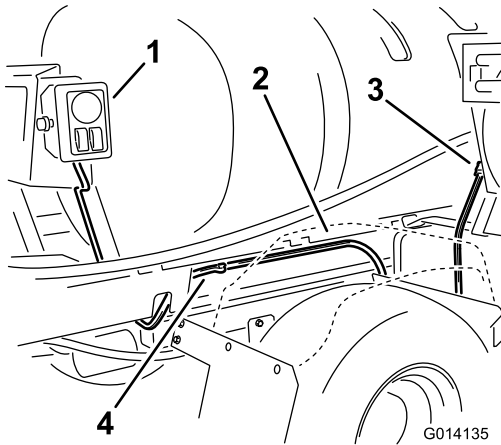

Figure 18

- | | |
|--------------------|--|
| 1. Control box | 3. Hose reel connector |
| 2. Tank skid frame | 4. Electric hose reel harness, shorter end |

7. Connect the harness to the hose reel.
8. At the battery, install the fuse in to the open connector in the harness (Figure 17).
9. Replace the battery terminal covers and install the battery cover.
10. Use the strap to secure the cover to the battery box (Figure 16).
11. Install the 10 amp fuse into the fuse block.

6

Connecting the Spray Hose

Parts needed for this procedure:

1	Long hose with fitting
1	Spray gun
1	Hose clamp, small

Procedure

1. Wrap Teflon tape around the threads of the hose fitting on the long hose and install the fitting into the connecting tube on the reel (Figure 19).

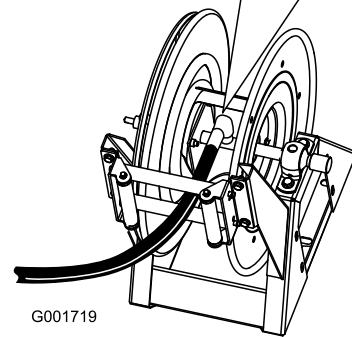
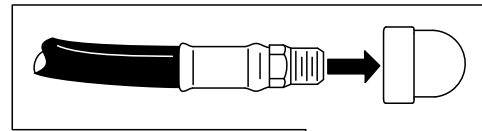

Figure 19

2. Connect the free end of the long hose to the fitting on the spray gun (Figure 20).

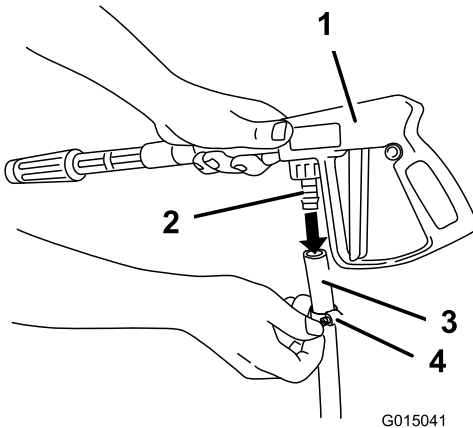

Figure 20

- | | |
|--------------|---------------|
| 1. Spray gun | 3. Hose |
| 2. Barb | 4. Hose clamp |

3. Secure the end of the hose with a small hose clamp. Ensure that the hose is fed through the guide opening before attaching the spray gun to the hose.
4. Connect the negative battery wire to the battery.
5. Press the hose wind button and carefully guide the hose onto the reel moving the hose from side to side to evenly distribute the hose.

⚠ CAUTION

Hands, loose clothing, long hair, and jewelry could get caught in the hose and reel while rewinding and cause injury.

- Keep your hands clear of the reel and hose while it is rewinding.
- Do not wear loose clothing or jewelry and tie up long hair.

Operation

⚠ WARNING

Fluid under pressure can penetrate skin and cause injury.

- Keep your body and hands away from nozzles that eject high pressure fluid.
- Do not aim the sprayer at any person or animal.
- Make sure all fluid hoses and lines are in good condition and all connections and fittings are tight before applying pressure to the system.
- Use cardboard or paper to find leaks.
- Safely relieve all pressure in the system before performing any work on it.
- Get immediate medical help if fluid is injected into skin.
- Hot liquids and chemicals can cause burns or other harm.

Turf Care Precautions While Operating in Stationary Modes

Important: Under some conditions, heat from the engine, radiator, and muffler can potentially damage grass when operating the sprayer in a stationary mode. Stationary modes include tank agitation, hand spraying, or using a walking boom.

Use the following precautions:

- **Avoid** stationary spraying when conditions are very hot and/or dry, as turf can be more stressed during these periods.
- **Avoid** parking on the turf while stationary spraying. Park on a cart path whenever possible.
- **Minimize** the amount of time the machine is left running over any particular area of turf. Both time and temperature affect how much the grass may be damaged.
- **Set the engine speed as low as possible** to achieve the desired pressure and flow. This will minimize the heat generated and the air velocity from the cooling fan.
- **Allow heat to escape** upward from the engine compartment by raising the engine guard/seat assemblies during stationary operation rather than being forced out under the vehicle. Refer to your Operator's Manual for more information on raising the seat assemblies.

Note: Use a heat shield blanket underneath the vehicle during stationary operation if additional heat protection is desired. Contact your Authorized Toro Dealer to obtain a Toro Heat Shield Blanket kit, for turf sprayers.

Switching from Boom Spray Mode to Hand Spray Mode

1. Stop the machine and set the parking brake.

⚠ WARNING

Driving while using the hand sprayer can cause loss of control, resulting in injury or death. Do not operate the hand sprayer while driving.

2. Set the throttle 25 percent of the way toward the Fast position.
3. Ensure that the pump switch is on and the Pro Control™ (if applicable) is set in the manual position.
4. Ensure that the trigger lock on the spray gun is locked.
5. Set the spray selection switch to the hand spray position (Figure 21).

Note: Hose reel accessories that require flows greater than 7 GPM may have reduced performance. The level of performance experienced by the operator is dependant upon accessory pressure required, accessory speed and other adjustable variables. For most reasonable settings, attachments will meet and exceed operator requirements. Please consult your nozzle selection guide for further information.

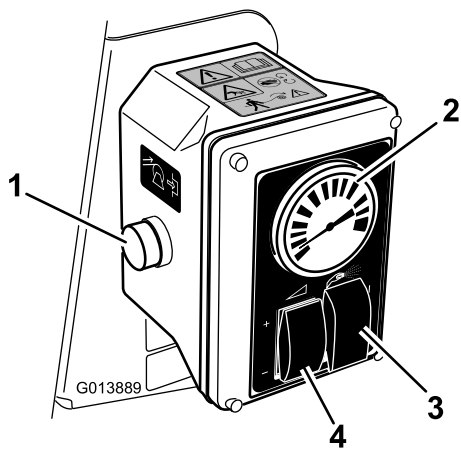

Figure 21

- | | |
|---------------------|---------------------------|
| 1. Hose wind switch | 3. Spray selection switch |
| 2. Pressure gauge | 4. Rate control switch |

- Adjust the rate control switch and the throttle to increase or decrease the pressure, as read on the pressure gauge, to the desired setting (Figure 21).

Note: Use the lowest throttle setting possible to achieve the desired pressure. This can be achieved by setting the pressure to maximum with the rate control switch and then adjusting the throttle speed until the desired pressure is obtained.

Note: The maximum recommended operating pressure of the hose reel kit is 150 psi.

Spraying with the Hand Sprayer

- Pull out the desired amount of hose from the reel.

Important: Do not pull the hose with the spray gun. Always hold the hose and pull on it directly. Pulling on the hose with the gun may break the fitting on the gun or damage the hose.

- Release the trigger lock.
- Direct the spray gun nozzle at the area to be sprayed and pull the trigger.
- Release the trigger and set the trigger lock when finished.

Switching from Hand Spray Mode to Boom Spray Mode

- Press the rate control switch to reduce the pressure.

CAUTION

Hands, loose clothing, long hair, and jewelry could get caught in the hose and reel while rewinding and cause injury.

- Keep your hands clear of the reel and hose while it is rewinding.
- Do not wear loose clothing or jewelry and tie up long hair.

- Set the spray selection switch to the off position.
- Direct the spray gun nozzle at an area where it is safe to spray, release the trigger lock, and pull the trigger until all remaining fluid is out of the hose, then set the trigger lock.
- Press the rewind button on the hose reel until only a few feet of hose is out of the reel.
- Return the spray gun to the holder on the back of the reel.

Important: An unsecured hose may catch objects and damage the hose reel.

Maintenance

Cleaning

The hand sprayer needs to be flushed after each use. When rinsing the booms, switch the sprayer to hand spray mode and activate the spray gun trigger several times to thoroughly rinse the hose assembly and the sprayer gun.

Notes:



Count on it.