



**Count on it.**

**Parts Catalog**

**Front Replacement Mower  
2011 and After Groundsmaster® 4000-D  
Traction Unit**

**Model No. 30478—Serial No. 312000001 and Up**



# Ordering Replacement Parts

To order replacement parts, please supply the part number, the quantity, and the description of each part desired.

## Understanding Reference Numbers

Each identified part in an illustration has a reference number. The reference number for a part also appears in the parts list, along with other information about the part.

This catalog uses two special reference number formats, one to indicate parts in a service assembly and another to indicate the quantity of a given part in an illustration.

## Service Assembly Reference Numbers

Parts in service assemblies have reference numbers in the form a:b. The a represents the reference number of the entire service assembly and the b represents a sequential number unique to each part within the service assembly.

For example, a wheel assembly might be identified by reference number 6, the tire by 6:1, the valve by 6:2, and the wheel by 6:3. When you order the assembly identified by reference number 6, you receive all parts identified by reference numbers 6:1, 6:2, and 6:3. However, you may also order any part individually. Reference numbers of this type appear in illustration and in parts lists.

## Reference Numbers Indicating Quantity

In an illustration, if a reference number indicates more than one part, the reference number has the form nX y. The n represents the quantity of the part, the X is the multiplication symbol, and the y represents the reference number.

For example, in an illustration, the reference number 2X 37 means that two of the parts identified by reference number 37 are indicated.

# List of Abbreviations

**AR:** as required

**ASM:** assembly

**BBC:** blade brake control

**BHTF:** button head thread forming

**CARR:** carriage

**CCW:** counter clockwise

**CW:** clockwise

**DEG:** degrees

**DPA:** Dual Point Adjustment

**ECM:** electronic control module

**EXT:** external

**FH:** flat head

**GA:** gauge

**HD:** heavy-duty

**HF:** hex flange

**HH:** hex head

**HHF:** hex head flange

**HHFTF:** hex head flange thread forming

**HJ:** hex jam

**HLH:** hex lag head

**HOC:** height-of-cut

**HSBH:** hex socket button head

**HSFH:** hex socket flat head

**HSH:** hex socket head

**HWH:** hex washer head

**HWHTF:** hex washer head thread forming

**HYD:** hydraulic

**LH:** left hand

**LPG:** Liquid Propane Gas

**NI:** nylon insert

**NPTF:** national pipe thread fine

**PFH:** phillips flat head

**PPH:** phillips pan head

**PPHTF:** phillips pan head thread forming

**PRH:** phillips round head

**PTH:** phillips truss head

**PTO:** power-take-off

**RH:** right hand

**ROPS:** roll-over protection system

**RRB:** rear roller brush

**SFH:** slotted fillister head

**SHH:** slotted hex head

**SHWH:** slotted hex washer head

**SPH:** slotted pan head

**SQH:** square head

**SRH:** slotted round head

**STD:** standard

**TAP:** self tapping

**TTH:** torx truss head

# Contents

Front Deck, Idler and Skid Assembly .....	4
Double Driven Spindle Assembly No. 119-4548 .....	6
High Driven Spindle Assembly No. 119-4549 .....	7
Front Deck Caster Arm and Wheel Assembly .....	8
Front Spindle Installation Assembly .....	9
Front Deck Chamber and Cover Assembly .....	10

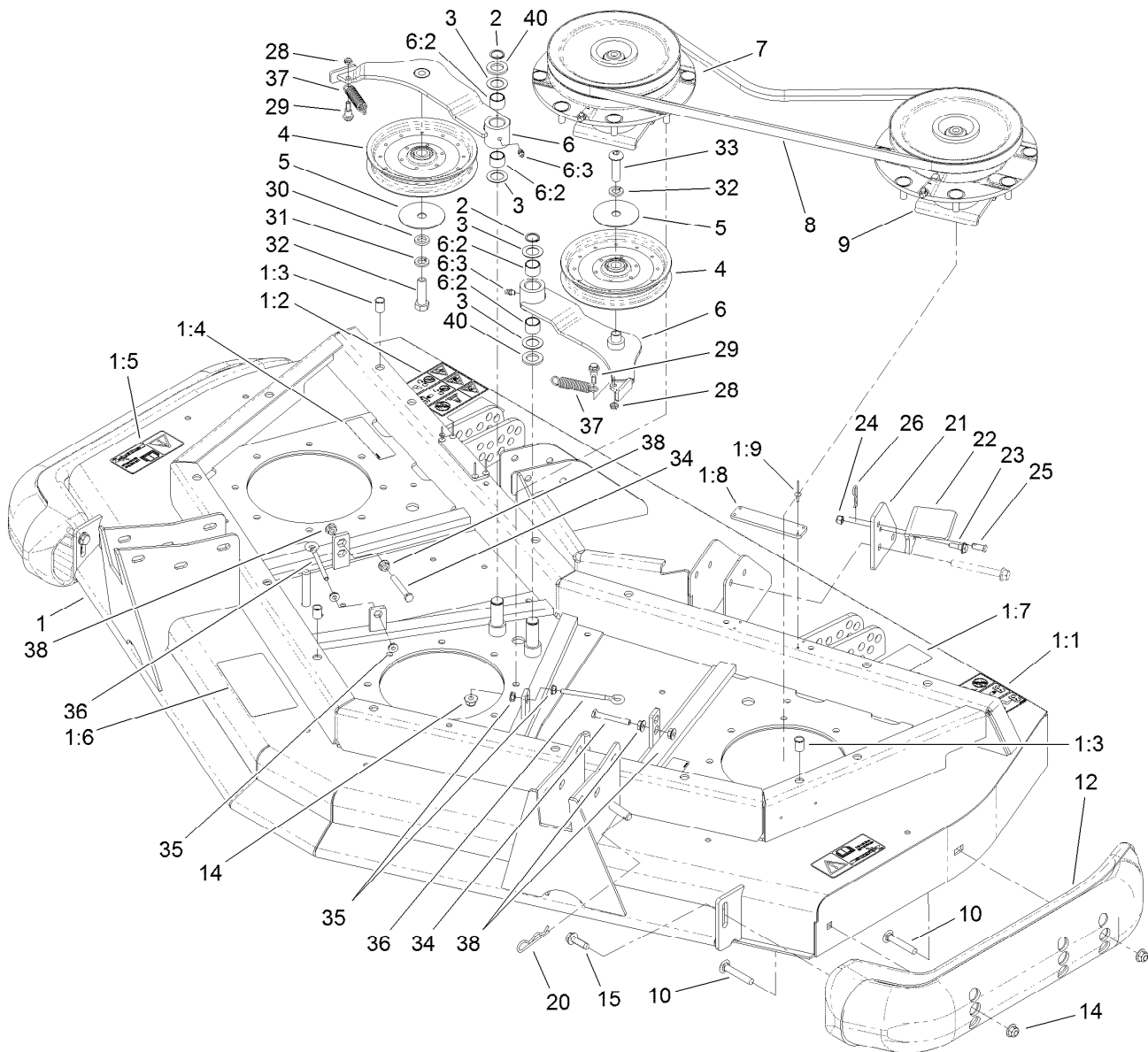

## Front Deck, Idler and Skid Assembly

Ref.	Part Number	Qty.	Description	Ref.	Part Number	Qty.	Description
1	120-4052	1	Front Deck ASM	12	112-1479	2	Skid-Bumper, Deck
1:1	120-6604	2	Decal-Danger	14	104-8301	24	Nut-Flange, NI
1:2	100-5624	1	Decal-HOC, RH	15	9136144	2	Screw-HWHTF
1:3	32148-9	3	Insert-Nut	20	3290-355	1	Pin-Hair
1:4	100-6578	4	Decal-Danger	21	106-2033-01	1	Plate-Latch
1:5	93-7818	2	Decal-Torque, Blade Bolt	22	106-2032-01	1	Latch-Deck
1:6	100-5622	1	Decal-HOC	23	11-9030	1	Screw-Shoulder
1:7	104-3578	1	Decal-HOC, LH	24	3296-42	1	Nut-Lock, NI
1:8	105-0786	2	Pad-Plastic	25	283-62	1	Pin-Clevis
1:9	3269-8	8	Rivet-Blind	26	3290-467	1	Pin-Hair
2	32120-72	2	Ring-Snap	28	3296-56	2	Nut-Lock, NI
3	3-6498	4	Washer-Thrust	29	104-0858	2	Bolt-Shoulder
4	110-9596	2	Pulley-Idler	30	9202424	1	Spacer
5	100-3102	2	Washer-Flat	31	3253-7	2	Washer-Lock
6	110-6128	2	Idler Arm ASM	32	325-7	1	Screw-HH
6:2	256-76	2	Bushing	33	108-1993	1	Screw-HSBH
6:3	302-5	1	Fitting-Grease	34	9114524	2	Bolt-TAP, HH
7	119-4548	1	Double Driven Spindle ASM	35	32128-14	4	Nut-HF
8	108-8076	2	V-Belt, Deck	36	68-0090	2	Screw-Adjusting
9	119-4549	1	High-Driven Spindle ASM	37	107938	2	Spring-Extension
10	3231-33	4	Screw-CARR				

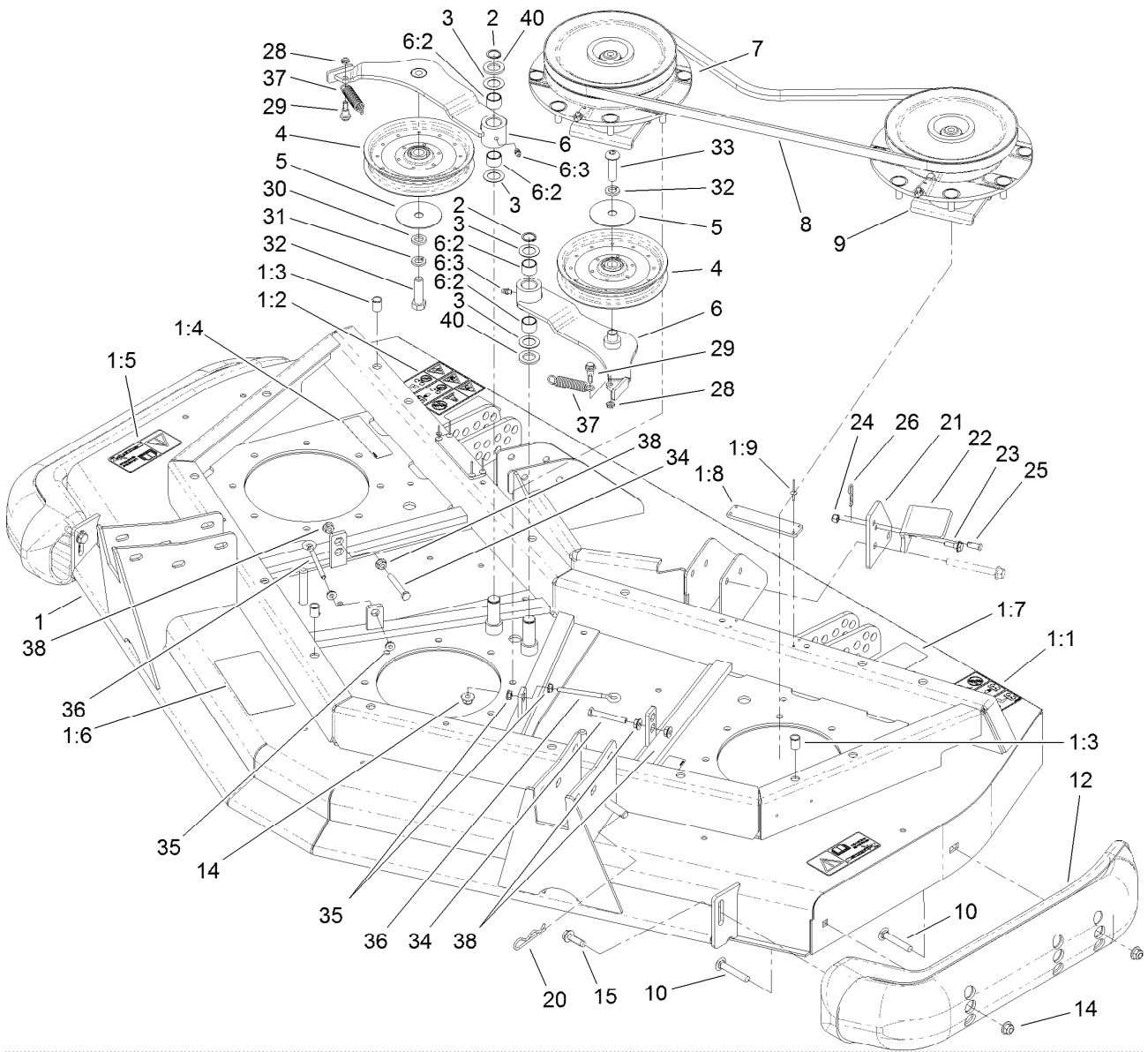

## Front Deck, Idler and Skid Assembly (continued)

Ref.	Part Number	Qty.	Description
38	32128-26	4	Nut-Flange
40	70-1160	2	Washer

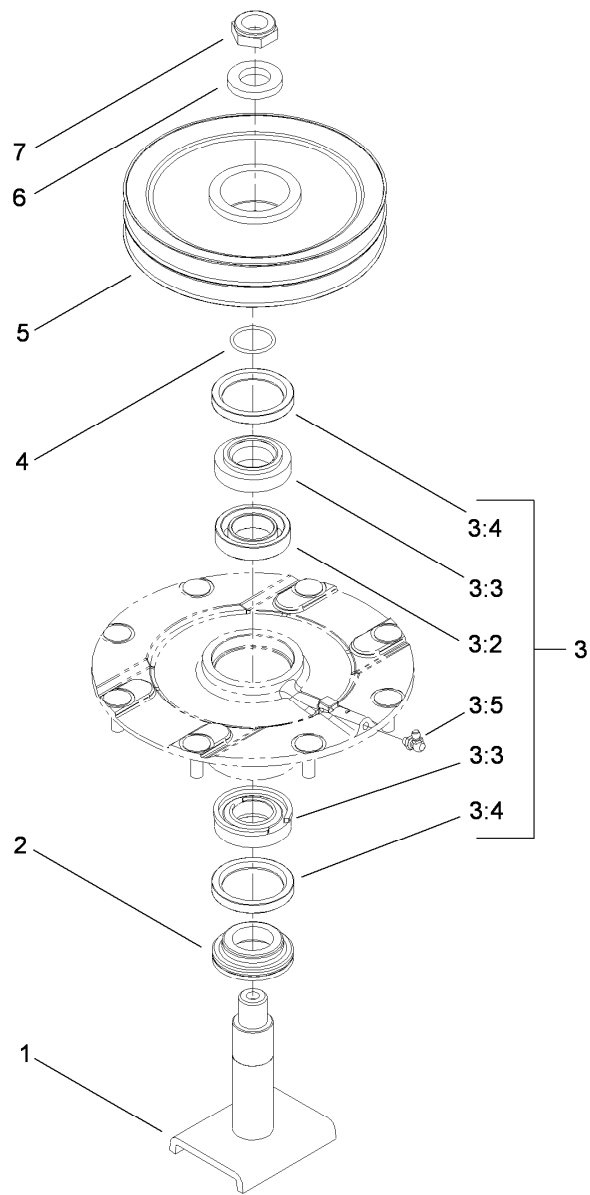

## Double Driven Spindle Assembly No. 119-4548

<i>Ref.</i>	<i>Part Number</i>	<i>Qty.</i>	<i>Description</i>
1	104-3554	1	Spindle Shaft ASM
2	69-6950	1	Spacer-Shaft, Spindle
3	119-4775	1	Spindle Housing ASM
3:2	104-3549	1	Bearing Spacer Set
3:3	110-8297	1	Bearing ASM
3:4	253-154	2	Seal-Oil
3:5	302-60	1	Fitting-Grease
4	106-7159	1	O-Ring
5	104-3547	1	Pulley-Driven, Double
6	104-8322	1	Washer-Hardened
7	3296-60	1	Nut-Lock, NI

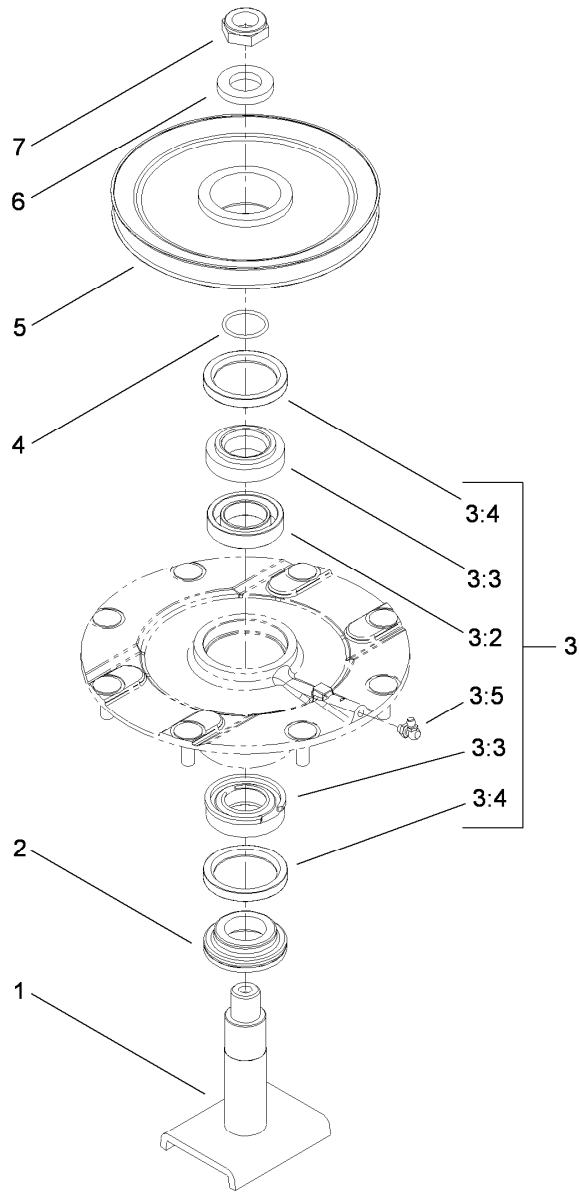

## High Driven Spindle Assembly No. 119-4549

<i>Ref.</i>	<i>Part Number</i>	<i>Qty.</i>	<i>Description</i>
1	104-3554	1	Spindle Shaft ASM
2	69-6950	1	Spacer-Shaft, Spindle
3	119-4775	1	Spindle Housing ASM
3:2	104-3549	1	Bearing Spacer Set
3:3	110-8297	1	Bearing ASM
3:4	253-154	2	Seal-Oil
3:5	302-60	1	Fitting-Grease
4	106-7159	1	O-Ring
5	104-3548	1	Pulley-Driven, High
6	104-8322	1	Washer-Hardened
7	3296-60	1	Nut-Lock, NI

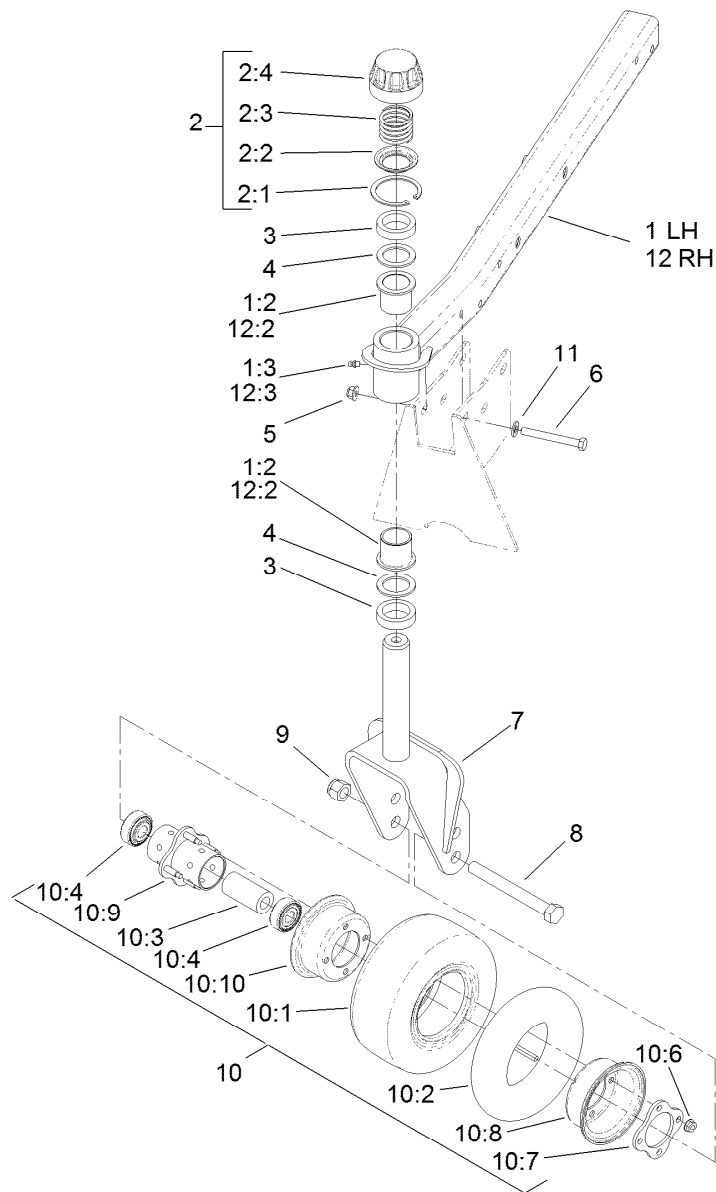

## Front Deck Caster Arm and Wheel Assembly

Ref.	Part Number	Qty.	Description	Ref.	Part Number	Qty.	Description
1	100-8092	1	Front LH Castor Arm ASM	10	93-9938	2	8 Inch Wheel ASM
1:2	69-6470	2	Bushing-Castor	10:1	93-9939	1	Tire
1:3	302-5	1	Fitting-Grease	10:2	68-8950	1	Tube-Inner (W/Valve)
2	92-9727	2	HOC Cap ASM	10:3	93-4241	1	Spacer-Bearing, Inner
2:1	92-5581	1	Ring-Retaining	10:4	120-3366	2	Bearing
2:2	92-5583	1	Washer-Cap	10:6	32128-16	4	Nut-HHF
2:3	92-9726	1	Spring-Compression	10:7	93-4242	1	Plate
2:4	92-8861	1	Cap-HOC	10:8	93-4239	1	Rim-Wheel, Half
3	69-1510	10	Spacer	10:9	93-5980	1	Hub
4	69-6860	4	Washer-Thrust	10:10	95-2741	1	Rim-Wheel, Half
5	104-8301	10	Nut-Flange, NI	11	3256-24	10	Washer-Flat
6	323-20	10	Screw-HH	12	100-8091	1	Front RH Castor Arm ASM
7	104-0762-01	2	Castor Fork ASM	12:2	69-6470	2	Bushing-Castor
8	327-24	2	Screw-HH	12:3	302-5	1	Fitting-Grease
9	3296-53	2	Nut-Lock, NI				
10	93-5974	2	8 Inch Foam Filled Wheel ASM ●				

● Optional Equipment

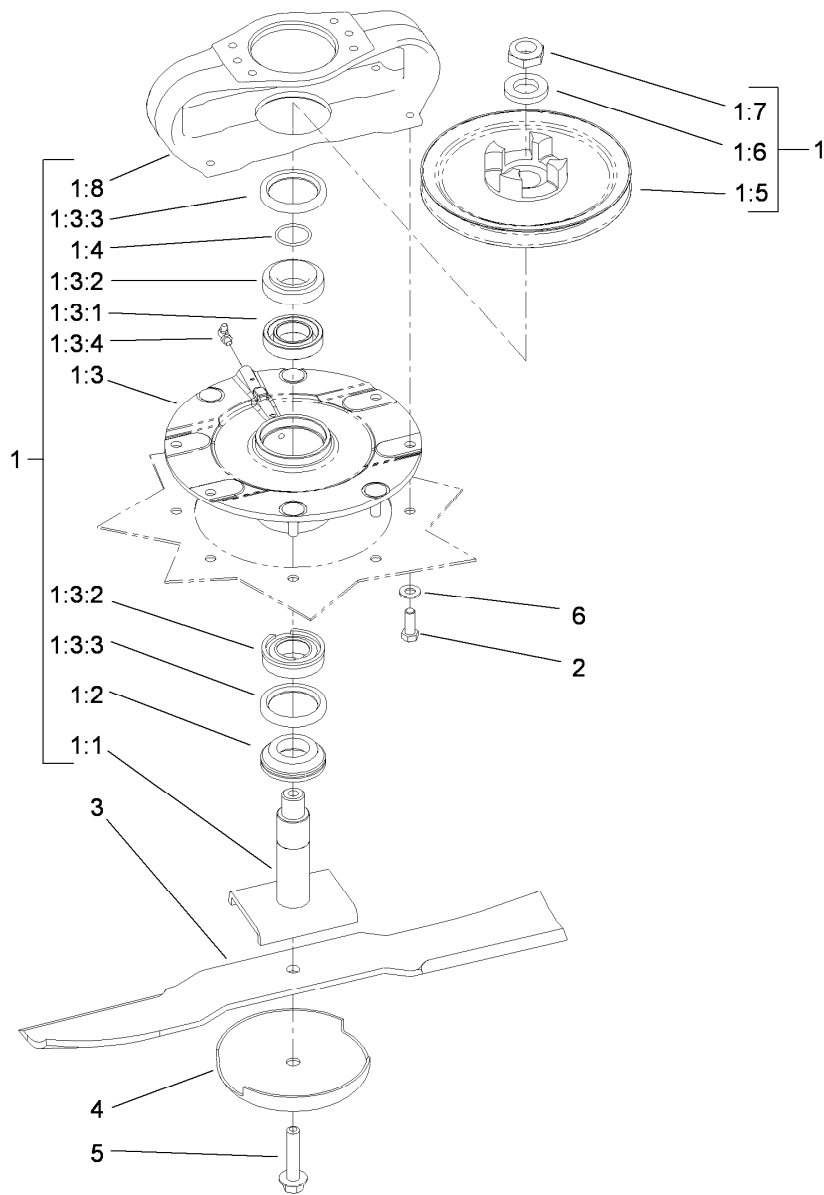

## Front Spindle Installation Assembly

<i>Ref.</i>	<i>Part Number</i>	<i>Qty.</i>	<i>Description</i>	<i>Ref.</i>	<i>Part Number</i>	<i>Qty.</i>	<i>Description</i>
1	119-4547	1	Driving Spindle ASM	1:5	104-3545	1	Pulley-Driving
1:1	104-3554	1	Spindle Shaft ASM	1:6	104-8322	1	Washer-Hardened
1:2	69-6950	1	Spacer-Shaft, Spindle	1:7	3296-60	1	Nut-Lock, NI
1:3	119-4546	1	Spindle Housing ASM	1:8	104-3544	1	Mount-Motor, Drive
1:3:1	104-3549	1	Bearing Spacer Set	2	323-6	4	Screw-HH
1:3:2	110-8297	1	Bearing ASM	3	92-5608-03	3	Blade
1:3:3	253-154	2	Seal-Oil	4	72-9361	3	Cup-Scalp, Anti
1:3:4	302-60	1	Fitting-Grease	5	92-5816	3	Bolt-Blade
1:4	106-7159	1	O-Ring	6	3256-24	4	Washer-Flat

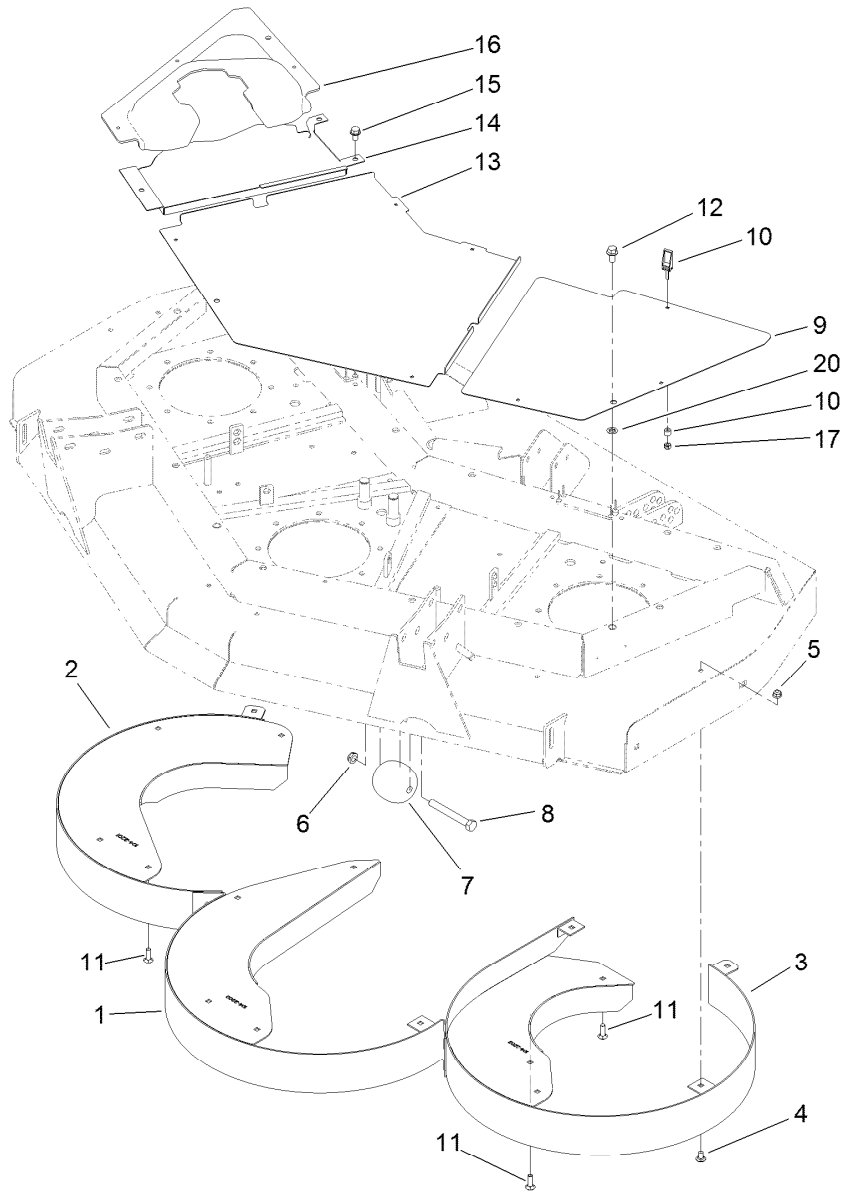

## Front Deck Chamber and Cover Assembly

<i>Ref.</i>	<i>Part Number</i>	<i>Qty.</i>	<i>Description</i>	<i>Ref.</i>	<i>Part Number</i>	<i>Qty.</i>	<i>Description</i>
1	104-2200-01	1	Center Chamber ASM	10	74-5950	10	Latch-Swell
2	104-2201-01	1	RH Chamber ASM	11	3230-22	3	Screw-CARR
3	104-2202-01	1	LH Chamber ASM	12	3234-1	3	Screw-HHF
4	3230-18	15	Screw-CARR	13	100-5660-03	1	Cover-Front, Center
5	104-8300	18	Nut-Flange, NI	14	100-5662-03	1	Cover-Front, RH
6	3296-45	2	Nut-Lock, NI	15	32144-69	3	Screw-HWHTF
7	29-4820	2	Roller	16	100-5661	1	Cover-Front, Center
8	325-17	2	Screw-HH	17	1-804254	10	Nut-Lock, HH
9	100-5663-03	1	Cover-Front, LH	20	107-3154	3	Nut-Push

**Notes:**



**Count on it.**