



Sonic Boom™ Kit

2010 and After Multi-Pro® Turf Sprayers and Workman® 200 Spray System

Model No. 41218—Serial No. 311000001 and Up

Installation Instructions

This attachment maintains consistent distances from the boom nozzles to the ground when spraying over uneven surfaces and is intended to be used by professional, hired operators in commercial applications. It is primarily designed for spraying golf course applications, parks, sports fields, and on commercial grounds. It is designed to only be used in conjunction with machines designated by the manufacturer.

This product complies with all relevant European directives. For details, please see the separate product specific Declaration of Conformity (DOC) sheet.

Safety

Safety and Instructional Decals



Safety decals and instructions are easily visible to the operator and are located near any area of potential danger. Replace any decal that is damaged or lost.



94-8582

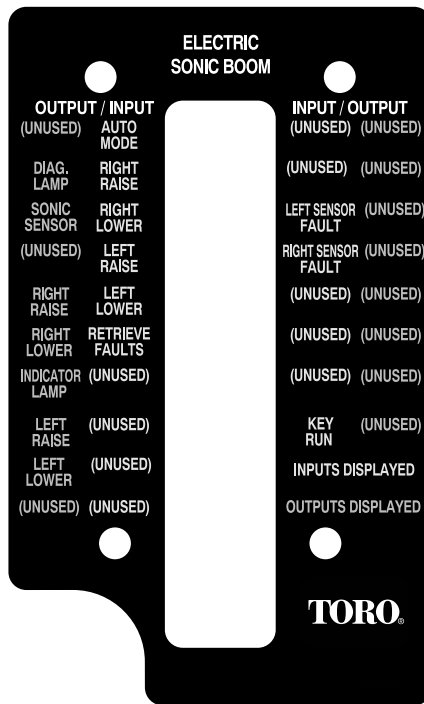

119-9431

Installation

Loose Parts

Use the chart below to verify that all parts have been shipped.

Procedure	Description	Qty.	Use
1	No parts required	–	Prepare the machine.
2	No parts required	–	Remove the hardstops.
3	Hinge Angled strap (for an uncovered boom) Angled strap (for a covered boom) Top or bottom strap Compression spring Bushing Hex-head bolt (5/16 x 3-1/4 inch) Flat washer Locknut (5/16 inch)	2 2 2 2 4 8 4 12 4	Assemble the sensor mounting hardware.
4	Sonic boom sensor Bracket Programming plug Sensor cover Lower sensor housing Cap tube Sensor guard bracket Sensor cable (4 m) Large nut U-bolt Locknut (1/4 inch) Bolt (5/16 x 3/4 inch) Bolt (5/16 x 1-1/4 inch) Locknut (5/16 inch) Cable tie	2 2 2 2 2 2 2 2 4 6 12 12 4 8 12	Install the sonic boom sensors.
5	Mount plate Relay Bolt (1/4 x 5/8 inch) Lock washer (1/4 inch) Nut (1/4 inch) Wire harness Screw (#10) Nut (#10) Electronic Control Unit (ECU) Bolt (1/4 x 1-1/4 inch) Locknut (1/4 inch) Bolt (5/16 x 3/4 inch) Lock washer (5/16 inch) Flat washers U-bolt clamps Nut (5/16 inch)	1 4 4 4 4 1 4 4 1 4 4 2 2 2 2 2 4	Mount the electronic controls.

Procedure	Description	Qty.	Use
6	Decal, 94-8582	1	Install the indicator light.
	Light assembly	1	
7	Rocker switch	1	Install the controls.
	Cable ties	6	
	Indicator light (Workman 200 only)	1	
	Grommet (Workman 200 only)	1	
8	No parts required	–	Calibrate the sonic booms.

Note: Decal 119-9431 is used with a hand-held diagnostic tool and therefore is not installed on the machine.

Note: Determine the left and right sides of the machine from the normal operating position.

1

Preparing the Machine

No Parts Required

Procedure

Position the machine on a level surface, stop the engine, remove the ignition key, and engage the parking brake.

CAUTION

If you leave the key in the ignition switch, someone could accidentally start the engine and seriously injure you or other bystanders.

Remove the key from the ignition switch before install the kit.

2

Removing the Hardstops

No Parts Required

Procedure

If your machine has hardstops installed, they must be removed before installing the Sonic Boom Kit. The hardstops are located in the center boom of the caged booms and can be seen when the booms are in the upright, transport position. If your machine does not have hardstops installed, skip to the next procedure.

1. Raise the booms into the transport position and remove the ignition key.
2. Remove the 4 bolts (5/16 x 1 inch) and nuts (5/16 inch) that secure the stops to the center boom frame as shown in (Figure 1).

Note: Remove the hardstop assemblies on both sides of the center boom. Retain all parts for later use.

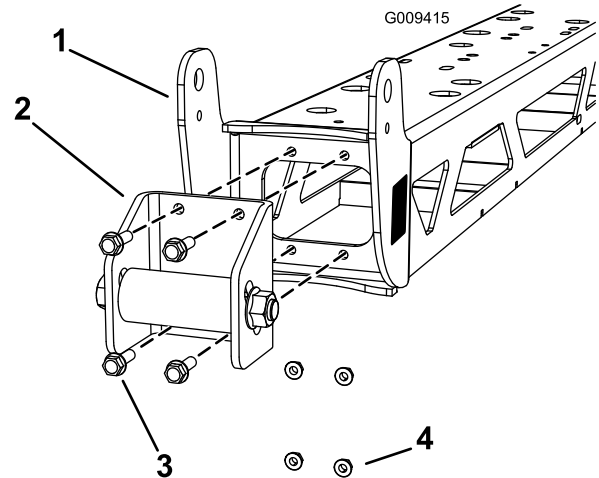

Figure 1

Right side shown

- | | |
|---------------------------------|-------------------------|
| 1. Center boom assembly | 3. Bolt (5/16 x 1 inch) |
| 2. Assembled bracket and bumper | 4. Nut (5/16 inch) |

3

Assembling the Sensor Mounting Hardware

Parts needed for this procedure:

2	Hinge
2	Angled strap (for an uncovered boom)
2	Angled strap (for a covered boom)
2	Top or bottom strap
4	Compression spring
8	Bushing
4	Hex-head bolt (5/16 x 3-1/4 inch)
12	Flat washer
4	Locknut (5/16 inch)

Procedure

Note: How you assemble the sensor mounting hardware depends upon whether the Covered Boom Kit (model 41602) is installed.

1. Lay out the hinges and straps as shown in Figure 2 (for an uncovered boom) or Figure 3 (for a covered boom).

Note: There are 2 sets of 2 angled straps in loose parts. One set is for an uncovered boom and the other set is for a covered boom. You will have one set of 2 angled straps (either for the covered boom or for the uncovered boom) that you will not use on the machine.

Note: The top straps for the uncovered booms also serve as the bottom straps for the covered booms.

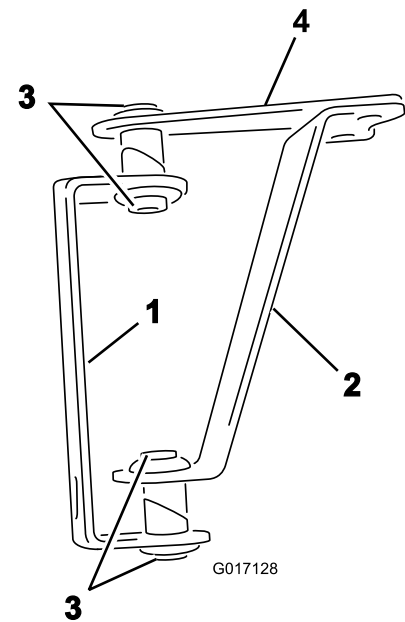

Figure 2

For uncovered booms only

- | | |
|---------------------|-----------------|
| 1. Hinge (2) | 3. Bushings (8) |
| 2. Angled strap (2) | 4. Top strap |

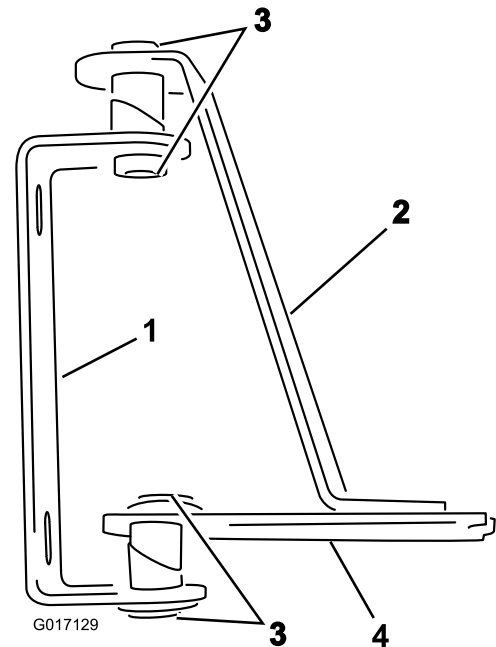

Figure 3

For covered booms only

- | | |
|---------------------|-----------------|
| 1. Hinge (2) | 3. Bushing (8) |
| 2. Angled strap (2) | 4. Bottom strap |

2. Insert the bushings into the welded tube openings in the hinges and straps as shown in Figure 2 or Figure 3.
3. Install a flat washer on each of the 2 hex-head bolts (3-1/4 inch).

- Insert the bolts through the hinged welded tube openings, hinges, and straps (Figure 4).

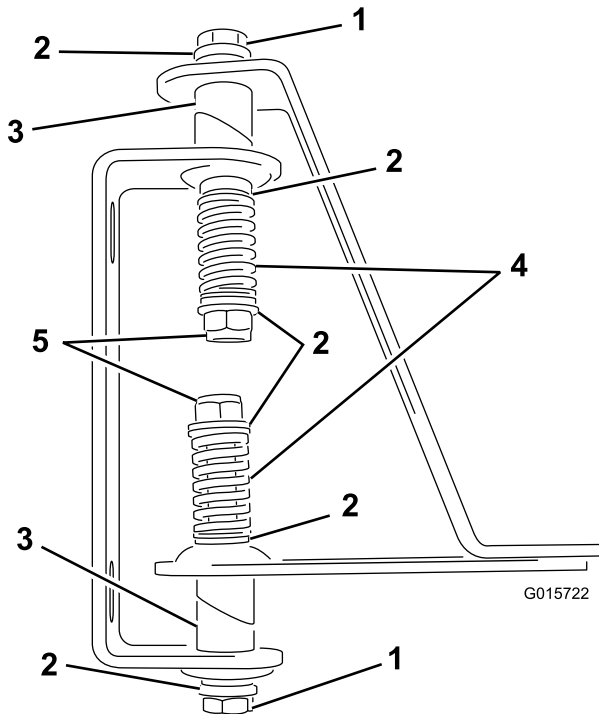

Figure 4

Hardware for a covered boom shown

- | | |
|------------------------|-------------------------|
| 1. Hex-head bolt | 4. Springs |
| 2. Flat washer | 5. Locknuts (5/16 inch) |
| 3. Welded tube opening | |

- Install a flat washer on the exposed end of each of the bolts.
- Install a spring on the end of each bolt (Figure 4).
- Install a flat washer and a locknut on the end of each bolt, and tighten the locknuts until there is no slack in the spring.

Note: Check to ensure that the hinges are not so tight that the mounted sensors do not freely pivot on the hinges.

4

Installing the Sonic Boom Sensors

Parts needed for this procedure:

2	Sonic boom sensor
2	Bracket
2	Programming plug
2	Sensor cover
2	Lower sensor housing
2	Cap tube
2	Sensor guard bracket
2	Sensor cable (4 m)
4	Large nut
6	U-bolt
12	Locknut (1/4 inch)
12	Bolt (5/16 x 3/4 inch)
4	Bolt (5/16 x 1-1/4 inch)
8	Locknut (5/16 inch)
12	Cable tie

Procedure

- Install a mounting bracket on the front side of each boom near the outermost nozzle with 3 U-bolts and 6 locknuts (1/4 inch) (Figure 5 and Figure 6).

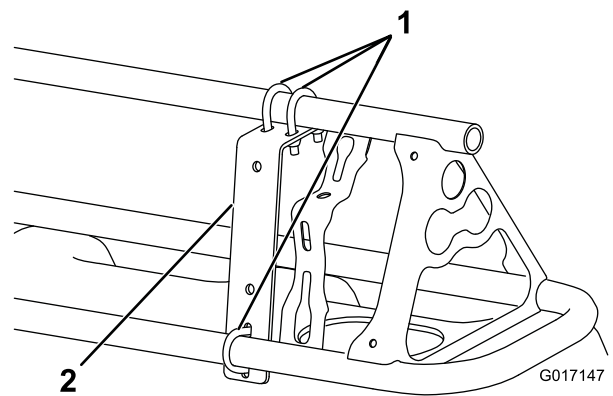

Figure 5

Front view

- | | |
|-------------------------|---------------|
| 1. Mounting bracket (2) | 2. U-bolt (6) |
|-------------------------|---------------|

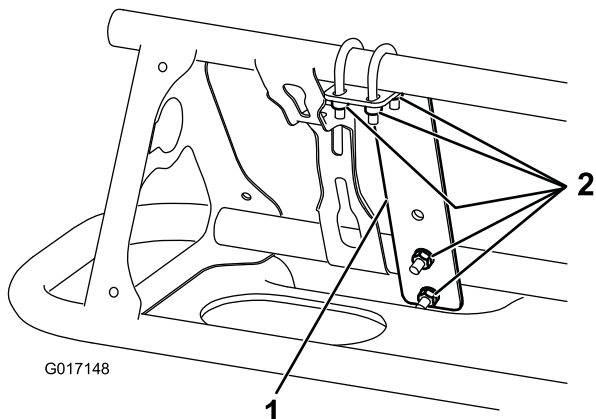

Figure 6
Rear view

1. Mounting bracket (2)
2. Locknuts (1/4 inch) (12)

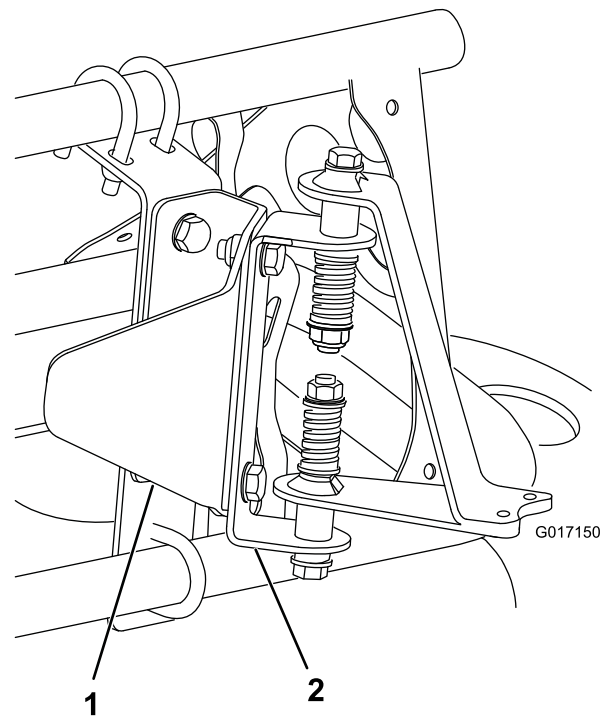

Figure 8

For a covered boom only

1. Sensor guard bracket
2. Hinge (of sensor mounting hardware)

2. Install the sensor guard bracket onto the mounting bracket with 2 bolts (5/16 x 3/4 inch) and 2 flange nuts (5/16 inch) as shown in Figure 7.

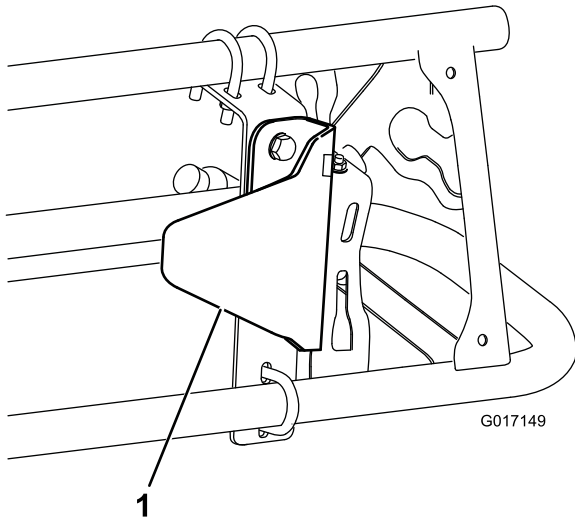

Figure 7

1. Sensor guard bracket

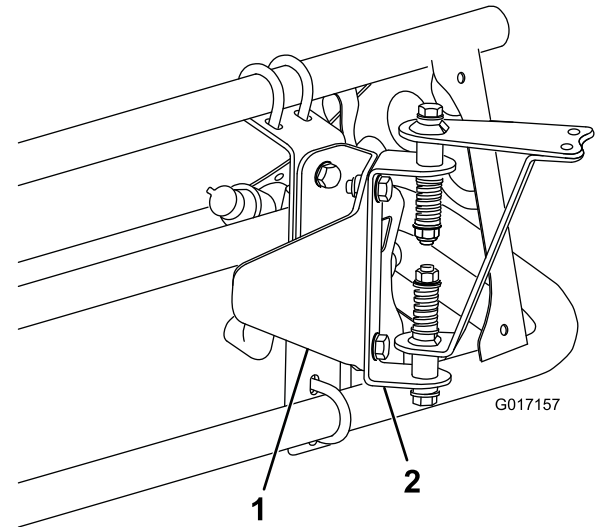

Figure 9

For an uncovered boom only

1. Sensor guard bracket
2. Hinge (of sensor mounting hardware)

3. Install the sensor mounting hardware onto the sensor guard bracket with 2 bolts (5/16 x 3/4 inch) and 2 locknuts (5/16 inch) as shown in Figure 8 (for a covered boom) or Figure 9 (for an uncovered boom).

4. Install the lower sensor housing onto the sensor mounting hardware with 2 bolts (5/16 x 1-1/4 inch) and 2 locknuts (5/16 inch) (Figure 10).

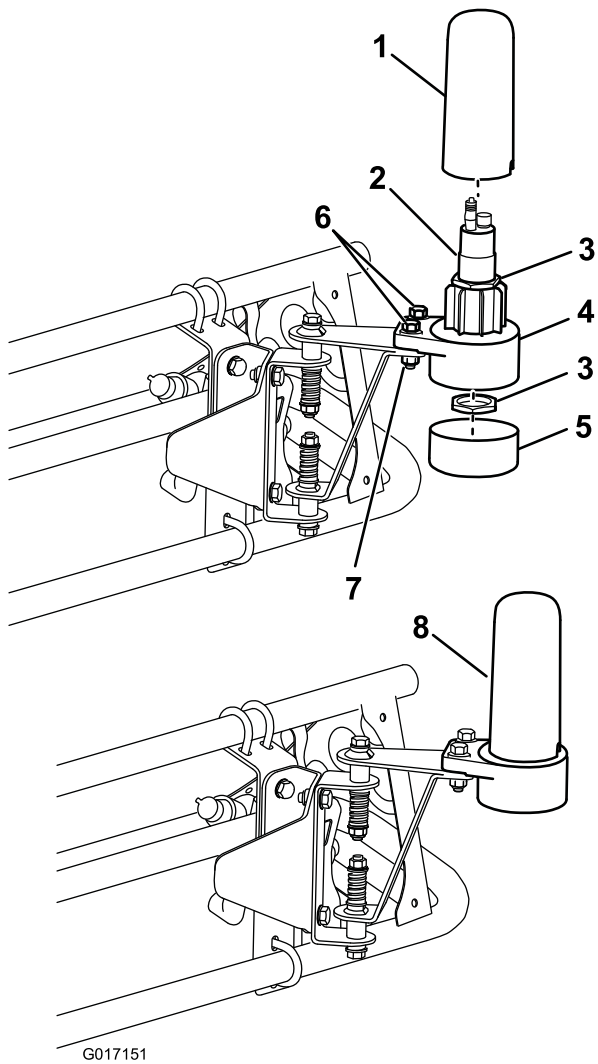

Figure 10

Uncovered boom configuration shown

- | | |
|-------------------------|------------------------------|
| 1. Cover | 5. Cap tube |
| 2. Sensor | 6. Bolts (5/16 x 1-1/4 inch) |
| 3. Large nut | 7. Locknuts (5/16 inch) |
| 4. Lower sensor housing | 8. Finished sensor assembly |

5. Install the programming plug on the sensor (Figure 11).

Important: Ensure that you align the arrow below the sideways “T” with the notch on the top edge of the sensor (Figure 11).

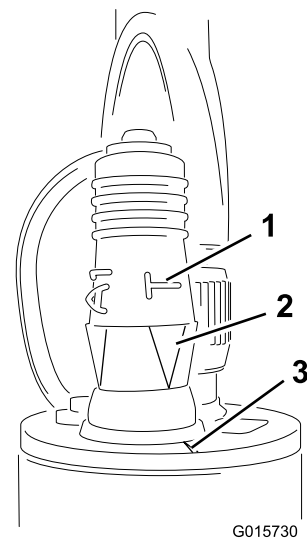

Figure 11

- | | |
|-------------------|-----------|
| 1. Sideways “T” | 3. Notch |
| 2. Arrows aligned | 4. Sensor |

6. Insert the sensor into the lower sensor housing, and secure it with 2 large nuts provided with the sensor (Figure 10).

Note: Discard the lock washers that come with the sensors.

7. Install the cap tube and the cover (Figure 10).

Note: Ensure that the sensor wire is routed through the small opening in the cover before installing the sensor cover.

8. Secure the wire coming from the sensor to the boom with cable ties.

Important: Ensure that you allow enough slack in the wire around the sensor so that the sensor can freely pivot on the hinge without pulling on the wire.

9. Repeat the steps above for the other boom.

Note: For covered booms only: The sensors should not detect the boom cover as this may interfere with the signal. If you experience any difficulties during the calibration process, check the sensors to ensure that their signals do not detect the boom cover.

5

Mounting the Electronic Control

Parts needed for this procedure:

1	Mount plate
4	Relay
4	Bolt (1/4 x 5/8 inch)
4	Lock washer (1/4 inch)
4	Nut (1/4 inch)
1	Wire harness
4	Screw (#10)
4	Nut (#10)
1	Electronic Control Unit (ECU)
4	Bolt (1/4 x 1-1/4 inch)
4	Locknut (1/4 inch)
2	Bolt (5/16 x 3/4 inch)
2	Lock washer (5/16 inch)
2	Flat washers
2	U-bolt clamps
4	Nut (5/16 inch)

Procedure

1. Secure 4 relays to the front of the mount plate with 4 bolts (1/4 x 5/8 inch), 4 lock washers (1/4 inch), and 4 nuts (1/4 inch) as shown in Figure 12.

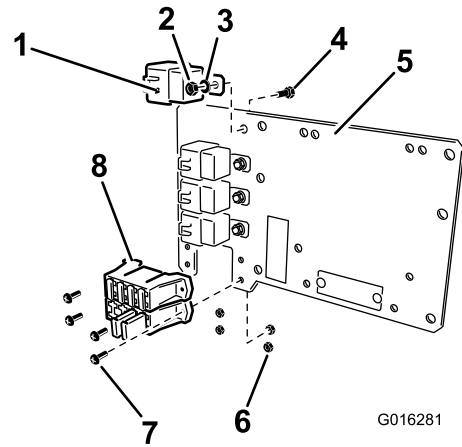

Figure 12

- | | |
|---------------------------|----------------|
| 1. Relay | 5. Mount plate |
| 2. Nut (1/4 inch) | 6. Nut (#10) |
| 3. Lock washer (1/4 inch) | 7. Screw (#10) |
| 4. Bolt (1/4 x 5/8 inch) | 8. Fuse block |

2. Secure the fuse block ends of the wiring harness to the mounting plate with 4 screws (#10) and 4 nuts (#10) as shown in Figure 12.
3. Secure the ECU to the mounting plate with 4 bolts (1/4 x 1-1/4 inch) and 4 locknuts (1/4 inch) as shown in Figure 13.

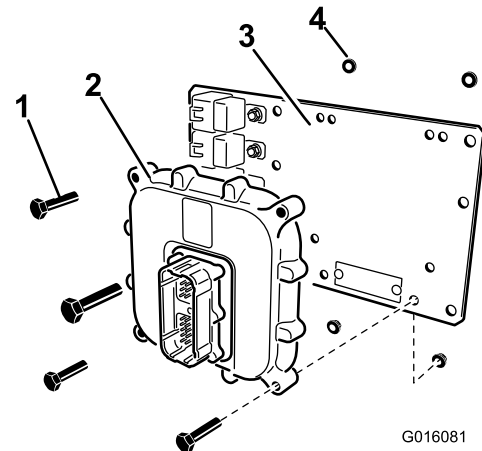

Figure 13

- | | |
|----------------------------|-----------------------|
| 1. Bolt (1/4 x 1-1/4 inch) | 3. Mount plate |
| 2. ECU | 4. Locknut (1/4 inch) |

4. Connect the relay leads on the wiring harness to the 4 relays on the mounting plate.
5. Connect the controller lead on the wiring harness to the ECU.
6. Install the mount plate to the vehicle frame, under the dashboard.
 - A. **For the Multi-Pro 1200 and 1250:** Install the mount plate using 2 bolts (5/16 x 3/4 inch), 2

lock washers (5/16 inch), and 2 flat washers as shown in Figure 14.

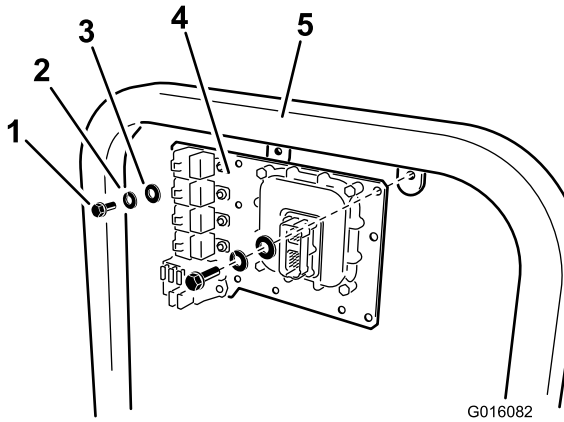

Figure 14

Frame under the dashboard

- 1. Bolt (5/16 x 3/4 inch)
- 2. Lock washer (5/16 inch)
- 3. Flat washer
- 4. ECM and Mount plate
- 5. Vehicle frame

B. For the Workman 200 Spray System: Install the mount plate using 2 U-bolt clamps and 2 nuts (5/16 inch) as shown in Figure 15.

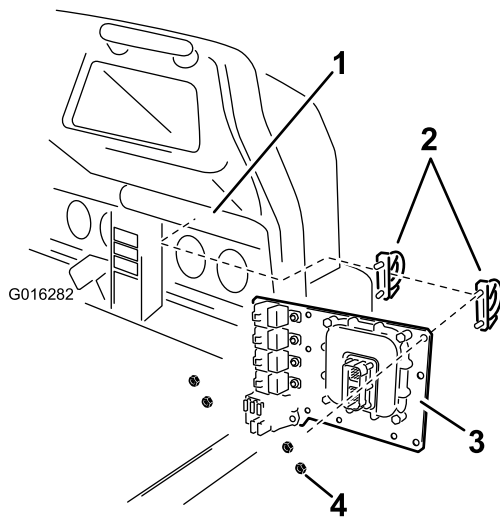

Figure 15

- 1. Vehicle frame
- 2. U-bolt assembly
- 3. Mount plate
- 4. Nut (5/16 inch)

6

Installing the Indicator Light

Parts needed for this procedure:

1	Decal, 94-8582
1	Light assembly

Procedure

1. Install decal 94-8582 over the light hole in the dash (Figure 16).

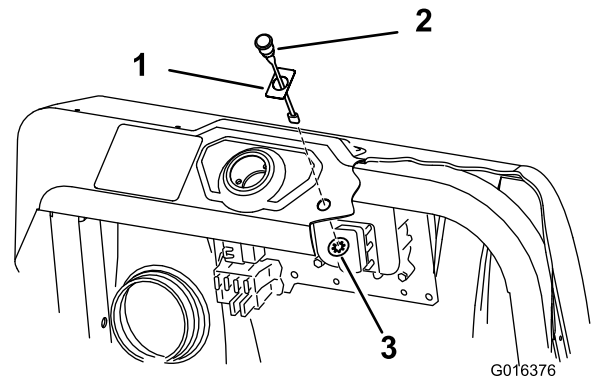

Figure 16

- 1. Decal 94-8582
- 2. Light
- 3. Push nut

2. Install the light in the dash and secure it from underneath the dash with the push nut (Figure 16).
3. Connect the light to the corresponding connector on the branch of the wiring harness.

7

Installing the Controls

Parts needed for this procedure:

1	Rocker switch
6	Cable ties
1	Indicator light (Workman 200 only)
1	Grommet (Workman 200 only)

Installing the Controls on a Multi Pro 1200 or 1250 Turf Sprayer

Installing the Switches

1. Remove the spray control panel to expose the bottom side (Figure 17 for the 1200 and Figure 18 for the 1250).

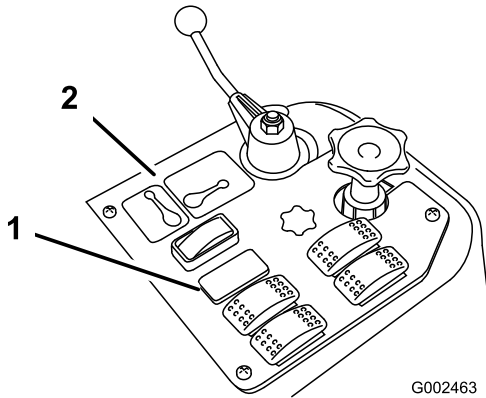

Figure 17
Multi Pro 1200

- | | |
|-------------------------------|------------------------|
| 1. Sonic boom switch location | 2. Spray control panel |
|-------------------------------|------------------------|

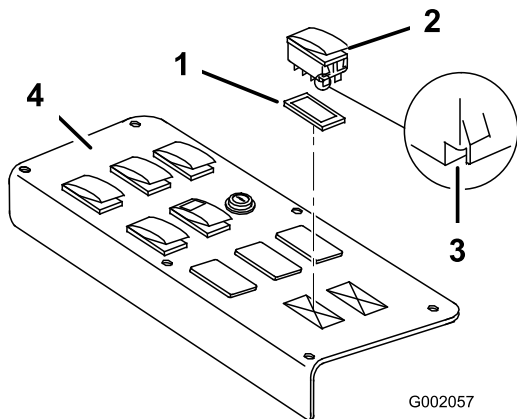

Figure 18
Multi Pro 1250

- | | |
|-----------|------------------------|
| 1. Plug | 3. Notch (at back) |
| 2. Switch | 4. Spray control panel |

2. Remove the plug in the sonic boom slot from the spray control panel on the vehicle, and install the rocker switch provided in its place (Figure 17 for the 1200 and Figure 18 for the 1250).

Note: Ensure that the orientation of the switch matches what is shown in Figure 18, with the notch pointing toward the rear of the vehicle.

Wiring the Switches

1. Route the branch of the sonic boom wire harness with the 3 large connectors into the control panel area.
2. If boom lift switches are installed, remove any existing connectors plugged into the lift switches.

3. Connect the connectors labeled “left boom lift switch” and “right boom lift switch” to the corresponding panel switches.
 4. Connect the connector labeled “sonic boom switch” to the sonic boom switch.
 5. Route the free end of the wiring harness down through the floor and rearward, following the spray system wire harness to the center boom assembly at the back of the vehicle.
- Note:** Use cable ties to secure the wiring harness to the other wiring harnesses away from the engine and moving parts.
6. Install the spray control panel and secure it with the fasteners that you removed previously.

Connecting the Wiring to the Fuse Block

1. Route the branch of the sonic boom wiring harness with the small spade connector and a ring or fork terminal into the seat box and to the fuse area.
2. Lift the seat to access the fuse area, and locate the auxiliary solenoid and ground terminal block.
3. Connect the ring labeled ground on the black wire to the ground terminal block (Figure 19).

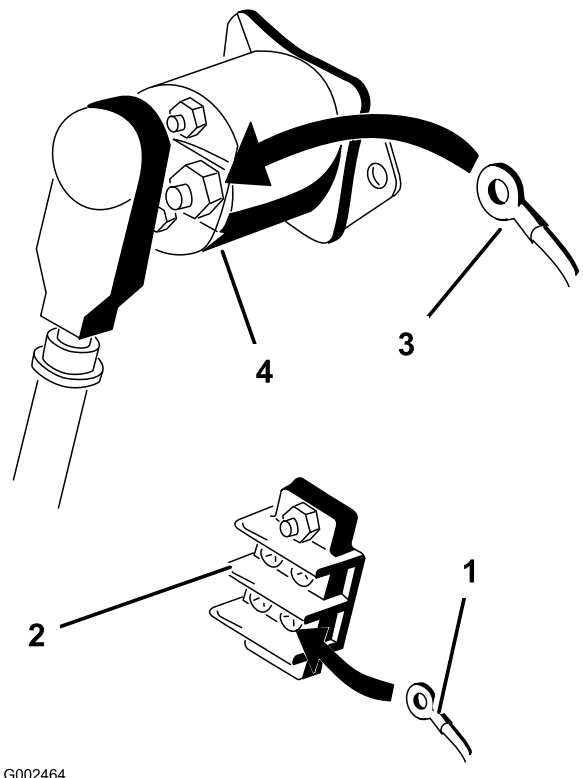

Figure 19

- | | |
|--------------------------|-----------------------|
| 1. Black wire | 3. Red wire |
| 2. Ground terminal block | 4. Auxiliary solenoid |
4. Connect the red wire to the load side of the auxiliary solenoid.

Note: The load side can be determined by testing both solenoid posts when the ignition is turned off. The hot side will read approximately 12V, while the load side will have no voltage. The load side can be confirmed by turning the ignition to the Run or On position and testing the load side again. The load side will read approximately 12V with the ignition on. Turn the ignition to Off and remove the key before continuing with any of the installation or maintenance.

5. Lower the seat.

Installing the Controls on a Workman Spray System

Install the Switches

1. Remove the fasteners that secure the front cover to the control panel housing to access the internal components.

Note: Retain all fasteners.

2. Drill a 0.50-inch diameter hole to accommodate the indicator light in control panel cover (Figure 20).

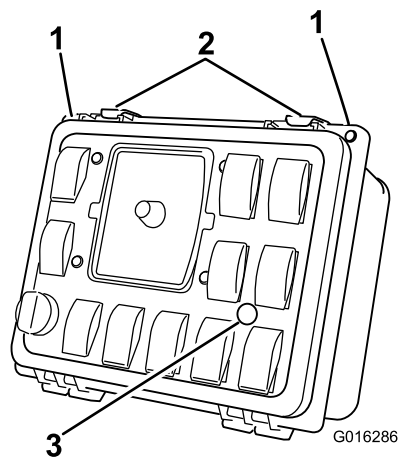
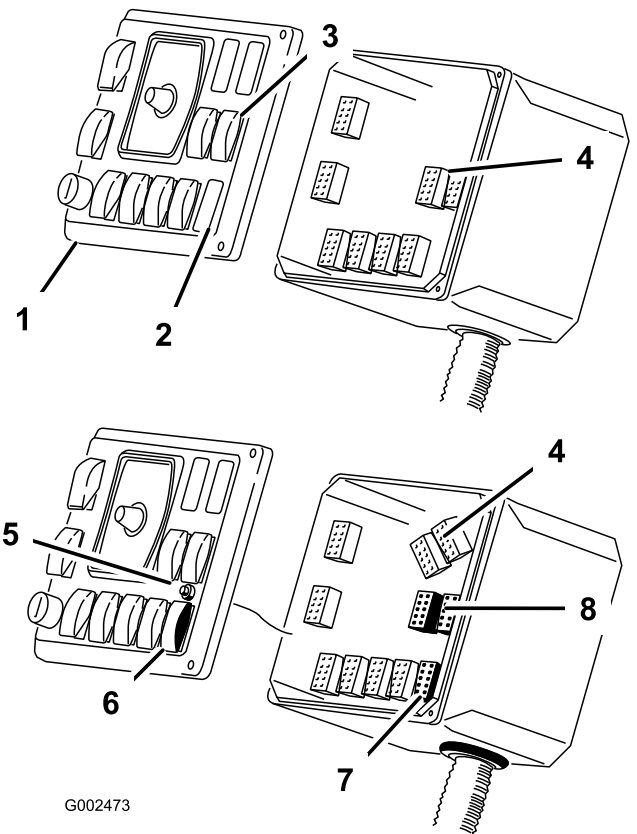

Figure 20

1. Screw
2. Latches
3. Drilled hole (0.50 inch diameter)

3. Install the indicator light through the back of the hole, and secure it to the front panel with the fasteners that are included(Figure 21).
4. Remove the sonic boom switch plug from the front panel, and install the sonic boom rocker switch (Figure 21).



G002473

Figure 21

- | | |
|----------------------------------|---|
| 1. Spray control panel | 5. Indicator light, install |
| 2. Sonic boom plug | 6. Sonic boom switch |
| 3. Existing boom lift switches | 7. Sonic boom connector, from sonic boom wire harness |
| 4. Existing boom lift connectors | 8. Boom lift connectors, from sonic boom wire harness |

5. Locate and disconnect the plugs for the boom lift switches (Figure 21).

Important: Do not cut or remove any unused connectors. Store the unused connectors in the control box for future use in the event that the sonic boom kit is removed.

6. Change the orientation of the boom lift switches:
 - A. Locate the boom lift switches in the control panel, and remove both switches from the panel.
 - B. Using a flat head screw driver or similar tool, gently pry the rocker switch covers from the switch bodies (Figure 22).

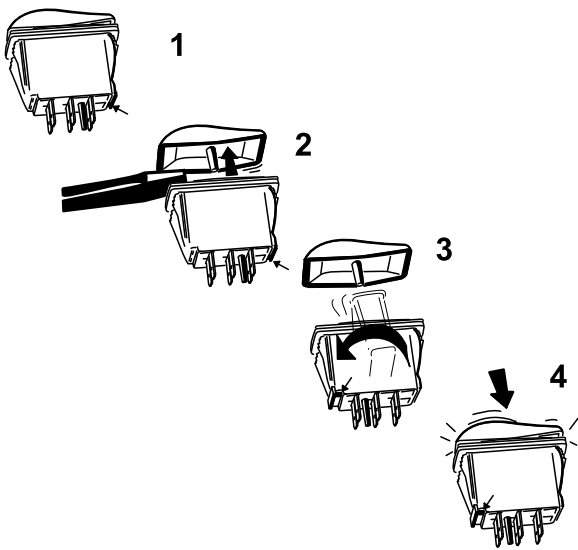

Figure 22

- | | |
|-----------------------------------|--------------------------------------|
| 1. Switch, with notch in the rear | 3. Switch body, rotated 180° |
| 2. Remove the cover | 4. Install cover, notch in the front |

C. Holding the switch cover in position, flip the switch body 180 degrees so that the connector notch is front left corner (Figure 22).

D. Press the rocker switch covers onto the switch bodies in this new orientation until the cover snaps into place (Figure 22).

E. Install the switches to their original position in the control panel.

Note: Ensure that the orientation of the notch of the switch points toward the top left of the control box.

Wiring the Switches and Indicator Light

1. Cut and remove the existing grommet in the base of the control panel. Discard the grommet.

Important: Take precautions not to cut the existing wires and harness when cutting out the existing grommet.

2. Route the free end of the wiring harness up through the opening in the control panel, keeping the branch with the ring terminal outside the control panel.
3. Split the new grommet included in the kit and wrap the around the wiring harness at the base of the control panel.
4. Install the grommets to the base of control panel in place of the grommet that you removed previously.
5. Connect the connectors labeled “left boom lift switch” and “right boom lift switch” to the corresponding panel switches.

6. Connect the connector labeled “sonic boom switch” to the sonic boom switch.
7. Connect the light indicator to the wiring harness with two spade connectors.
8. Install the front control panel cover to the control box using the fasteners that you removed previously (Figure 20).
9. Route the remainder of the harness rearward, along the existing sprayer harness to rear of the machine.
10. Secure the harnesses with cable ties.

Connecting the Wiring to the Fuse Block

1. Locate the branch of the wiring harness, with the ring terminal for ground and small power terminal, and route it under the dash to the fuse block area.
2. Connect the ring on the black wire to the ground bolt (Figure 23).

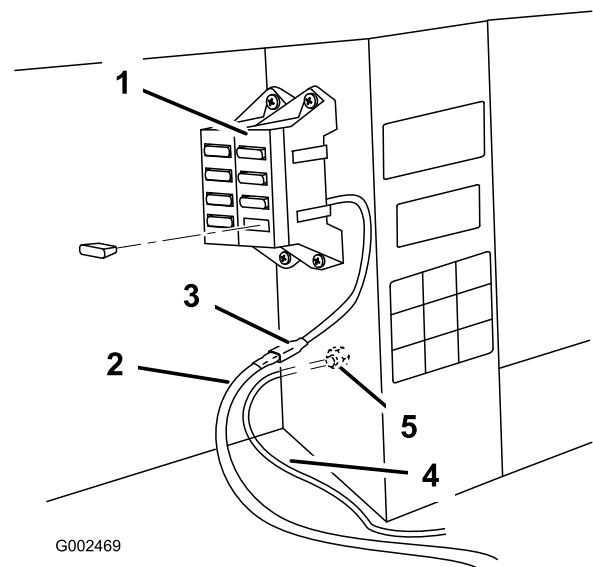

Figure 23

- | | |
|--|----------------|
| 1. Fuse block | 4. Black wire |
| 2. Red wire, from harness | 5. Ground bolt |
| 3. Corresponding wire, from fuse block | |

3. Remove the short extension wire from the red wire and connect the black connector to the mating connector in the fuse block.
4. Locate the long branch extending from middle of the wiring harness with the positive ring terminal.
5. Route the long branch along existing wiring to the battery area.
6. Remove the battery cover if necessary and connect the ring terminal to the positive battery post clamp using existing fasteners.

Note: Replace the cover if necessary.

Note: Tie back any loose wiring to protect it from being damaged.

8

Calibrating the Sonic Booms

No Parts Required

Procedure

In this procedure, you will have 20 seconds to calibrate the sensors on the booms. The distance you set between the sensor on each boom and the ground after the 20-second calibration period is the boom height setting in automatic mode until the next time you calibrate the sensor. After the 20 seconds, a self-calibrating process occurs for up to 2 minutes, during which the controller establishes this distance and then “learns” the flow characteristics of the hydraulic lift cylinder valves.

Note: For uncovered booms: The default height setting is 20 inches (51 cm) from the nozzle to the ground. If, after setting a boom to a height different from that of the factory default setting, you wish to restore the calibration to the factory-default setting, calibrate the boom with the boom in the cradle. **For covered booms:** The default height setting of 20 inches (51 cm) is for uncovered booms only. You must calibrate the sensors on covered booms.

1. Ensure that the turf sprayer is parked and away from any trees, buildings, vehicles, debris, and underground utilities and plumbing.
2. Lower the booms to the horizontal position; refer to the *Operator's Manual* for information on Adjusting the Actuators to level the booms.
3. Turn off the ignition key.
4. Press the sonic boom switch on the dashboard to the Auto position (Figure 24).

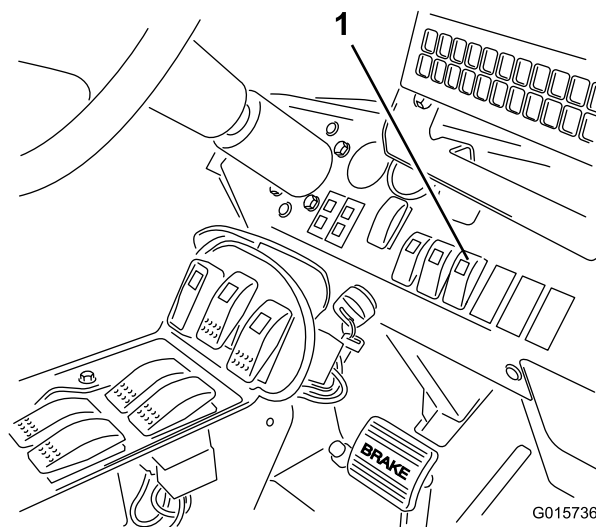

Figure 24

1. Sonic boom switch
5. While pressing and holding both the Left Lower switch and the Right Raise switch, turn the ignition key and start the machine.
6. Release the boom switches.
- Note:** The green light on the sonic boom switch will flash rapidly, indicating that the sonic boom system is in calibration mode. You now have 20 seconds to use the raise and lower boom switches to set the desired distance from the booms to the ground. After the 20 seconds, the green light will flash slowly.
7. Use the Raise and Lower switches to adjust the height of each boom until you achieve the desired distance from the sensor on the boom to the ground.
8. Allow the self-calibrating process to complete; wait for the slowly flashing green light on the sonic boom switch to stop.

Note: The self-calibrating process may take up to 2 minutes to complete. Do not interrupt the sensor signal during the self-calibration process, such as moving your foot under a sensor.

Operation

Using the Controls

The **Sonic boom switch** is located on the dashboard and has 2 settings: Automatic and Manual.

- **Automatic mode:** This mode enables the automatic movement of the booms, enabling the boom tips to continually remain the desired distance from the ground. To activate the automatic mode, press the sonic boom Auto mode switch and tap on the lower boom switch(es) to move the boom to the desired distance from the ground.

Note: You can temporarily override the automatic operation of the booms using the boom switches to raise or lower one or both booms. To lower the boom manually while the system is in automatic mode, hold the lower boom switch until you reach the desired boom height. To raise the boom manually while the system is in automatic mode, simply hold the raise boom switch until you reach the desired boom height. If you adjust only one boom, the other boom continues to function automatically. To resume the automatic mode, tap the lower boom switch to move the boom to the desired distance from the ground.

- **Manual mode:** This mode turns off the automatic adjustment of the booms, and allows you to control the booms manually.

The **Sonic boom light** is on the sonic boom switch displays the status of the sonic boom system as follows:

- **On continuously:** The sonic boom system is on and operating normally.
- **Flashing quickly:** The system is in calibration mode, which lasts for 20 seconds.
- **Flashing slowly:** There is an error in the system or you have overridden the automatic mode by operating one or both of the booms manually while the system is in automatic mode.

Note: In the event that there is a fault in the sonic boom system (e.g., there is no signal coming from a sensor), the boom will raise for a few seconds and then stop, and the light on the boom switch (located on the dashboard) will flash slowly, indicating that one of the booms has stopped. Also, the indicator light on the armrest will flash, indicating a fault.

The **indicator light** is the small red light located on the arm console and displays the status of the sonic boom system as follows:

- **On momentarily:** The light comes on when you activate the sonic boom system. The light will turn off after a few seconds and remain off as long as the system is operating properly.
- **Flashing:** There is an active fault in the sonic boom system.

Maintenance

Cleaning

Clean the sensors periodically with a damp cloth. If a sensor is damaged or excessively dirty, replace it.

Important: Do not spray water at or on the sensors. Water sprayed under even household pressure can damage the sensor. Always cover the sensors completely before washing the sprayer.

Note: When the booms are in the cradle for extended periods of time, the seal around each sensor (which is oriented upward) may get exposed to ultraviolet light and gradually deteriorate. Keep the bottom of the sensors from being exposed to direct sunlight whenever possible.

Storage

Whenever you are not using the sensors for an extended period of time, put the safety caps on the sensors to protect them from the outdoor elements.

Troubleshooting

Note: Refer to the service manual for additional diagnostic information.

Problem	Possible Cause	Corrective Action
One or both booms malfunction; the sonic boom light is Off.	<ol style="list-style-type: none"> 1. A fuse is blown. 2. The light is burned out. 3. The electronic controller or wiring is damaged. 	<ol style="list-style-type: none"> 1. Replace the fuse. 2. Replace the light. 3. Contact an Authorized Toro Distributor.
One or both booms malfunction; the sonic boom light flashes slowly.	<ol style="list-style-type: none"> 1. There is a minor system error. 2. There is a system error that repeats after clearing the error. 3. There is a hydraulic or mechanical failure. 	<ol style="list-style-type: none"> 1. Lower the affected boom(s) using the boom switch(es) to clear the error. 2. If the error repeats, contact an Authorized Toro Distributor. 3. Repair the hydraulic or mechanical problem.
One or both booms are malfunctioning; the sonic boom light is on.	<ol style="list-style-type: none"> 1. The sensor covers are blocking or swinging into the sensor path 	<ol style="list-style-type: none"> 1. Install cover to the top side of the sensor.

Notes:

Notes:



Count on it.