



**Count on it.**

**Parts Catalog**

**Z Master<sup>®</sup> Riding Mower  
with 52in TURBO FORCE<sup>®</sup> Side Discharge  
Mower**

**Model No. 74953—Serial No. 312000001 and Up**

# Ordering Replacement Parts

To order replacement parts, please supply the part number, the quantity, and the description of each part desired.

## Understanding Reference Numbers

Each identified part in an illustration has a reference number. The reference number for a part also appears in the parts list, along with other information about the part.

This catalog uses two special reference number formats, one to indicate parts in a service assembly and another to indicate the quantity of a given part in an illustration.

## Service Assembly Reference Numbers

Parts in service assemblies have reference numbers in the form a:b. The a represents the reference number of the entire service assembly and the b represents a sequential number unique to each part within the service assembly.

For example, a wheel assembly might be identified by reference number 6, the tire by 6:1, the valve by 6:2, and the wheel by 6:3. When you order the assembly identified by reference number 6, you receive all parts identified by reference numbers 6:1, 6:2, and 6:3. However, you may also order any part individually. Reference numbers of this type appear in illustration and in parts lists.

## Reference Numbers Indicating Quantity

In an illustration, if a reference number indicates more than one part, the reference number has the form nX y. The n represents the quantity of the part, the X is the multiplication symbol, and the y represents the reference number.

For example, in an illustration, the reference number 2X 37 means that two of the parts identified by reference number 37 are indicated.

# List of Abbreviations

**AR:** as required

**ASM:** assembly

**BBC:** blade brake control

**BHTF:** button head thread forming

**CARR:** carriage

**CCW:** counter clockwise

**CW:** clockwise

**DEG:** degrees

**DPA:** Dual Point Adjustment

**ECM:** electronic control module

**EXT:** external

**FH:** flat head

**GA:** gauge

**HD:** heavy-duty

**HF:** hex flange

**HH:** hex head

**HHF:** hex head flange

**HHFTF:** hex head flange thread forming

**HJ:** hex jam

**HLH:** hex lag head

**HOC:** height-of-cut

**HSBH:** hex socket button head

**HSFH:** hex socket flat head

**HSH:** hex socket head

**HWH:** hex washer head

**HWHTF:** hex washer head thread forming

**HYD:** hydraulic

**LH:** left hand

**LP:** Liquid Propane

**NI:** nylon insert

**NPTF:** national pipe thread fine

**PFH:** phillips flat head

**PPH:** phillips pan head

**PPHTF:** phillips pan head thread forming

**PRH:** phillips round head

**PTH:** phillips truss head

**PTO:** power-take-off

**RH:** right hand

**ROPS:** roll-over protection system

**RRB:** rear roller brush

**SFH:** slotted fillister head

**SHH:** slotted hex head

**SHWH:** slotted hex washer head

**SPH:** slotted pan head

**SQH:** square head

**SRH:** slotted round head

**STD:** standard

**TAP:** self tapping

**TTH:** torx truss head

# Contents

Frame and Caster Wheel Assembly .....	4
Roll-Over Protection System Assembly No. 116-0231 .....	5
Caster Wheel and Fork Assembly .....	6
Hydraulic Pump, Idler and Belt Assembly .....	7
Pump Idler Assembly No. 116-1255 .....	8
LH Hydro Assembly No. 116-6417 .....	9
RH Hydro Assembly No. 116-6418 .....	10
Rear Wheel and Park Brake Assembly .....	11
Parking Brake Handle Assembly No. 116-6861 .....	12
Fuel Tank Mounting Assembly .....	13
Fuel Tank Assembly No. 116-3978 .....	14
Seat Mounting Assembly .....	15
Seat Assembly No. 116-0038 .....	16
Motion Control Assembly .....	17
Fender, Console and Control Assembly .....	18
Electrical System Assembly .....	19
Decklift Assembly .....	20
Height-of-Cut Assembly No. 109-7438 .....	22
Engine, Muffler and Clutch Assembly .....	23
Deck Assembly .....	24
Deck Decal Assembly No. 114-5810 .....	25
Idler Assembly .....	26
Spindle Assembly No. 119-8560 .....	27
Rubber Deflector Assembly No. 108-2792 .....	28
Attachments and Accessories .....	29

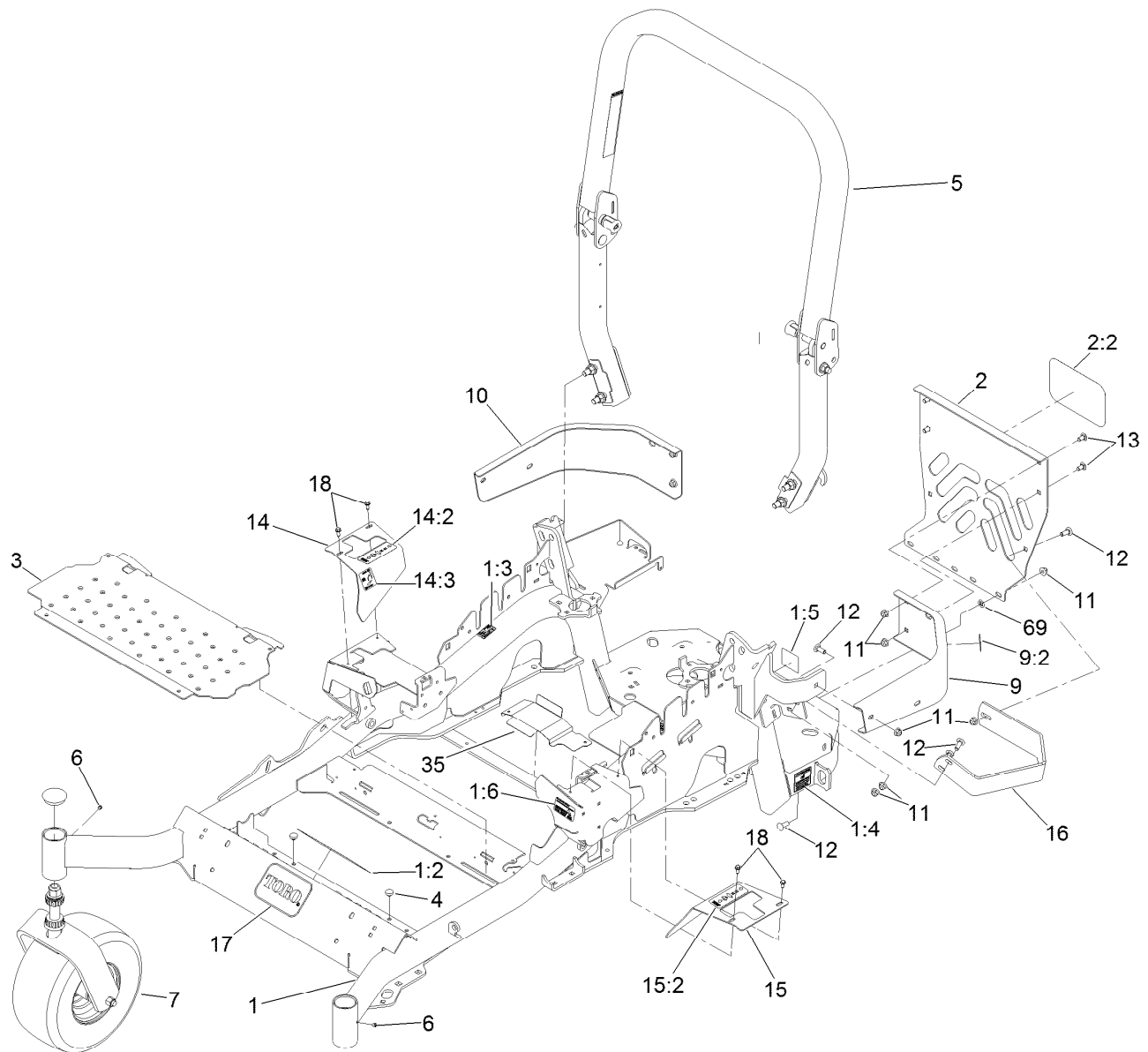

## Frame and Caster Wheel Assembly

Ref.	Part Number	Qty.	Description	Ref.	Part Number	Qty.	Description
1	116-5900	1	Mainframe ASM	10	116-0057-03	1	Bumper-RH
1:2	116-3303	1	Decal-Slope	11	104-8301	11	Nut-Flange, NI
1:3	103-2076	2	Decal-Caution	12	3231-22	7	Screw-CARR
1:4	116-0205	2	Decal-Belt Drive	13	3231-21	4	Screw-CARR
1:5	116-4858	1	Decal-Spark Arrester	14	116-5899	1	Cover-Motion Control, RH
1:6	116-1654	1	Decal-Fuel Fill	14:2	109-7232	1	Decal-Motion Control
2	115-7410	1	Rear Guard ASM	14:3	116-5944	1	Decal-Park Brake
2:2	67-7320	1	Decal	15	116-0580	1	LH Motion Control Cover ASM
3	116-0024-01	1	Floorpan	15:2	109-7232	1	Decal-Motion Control
4	1-513658	2	Bumper	16	116-0043-03	1	Guard-Muffler
5	116-0231	1	ROPS ASM	17	68-3640	1	Decal
6	1-811010	2	Plug	18	32144-10	4	Screw-HWH
7		2	Castor W/Fork ASM ●	35	116-2999-01	1	Guard-Belt
9	116-0180	1	LH Bumper ASM	69	107-3154	2	Nut-Push
9:2	103-2076	1	Decal-Caution				

● Not serviced separately

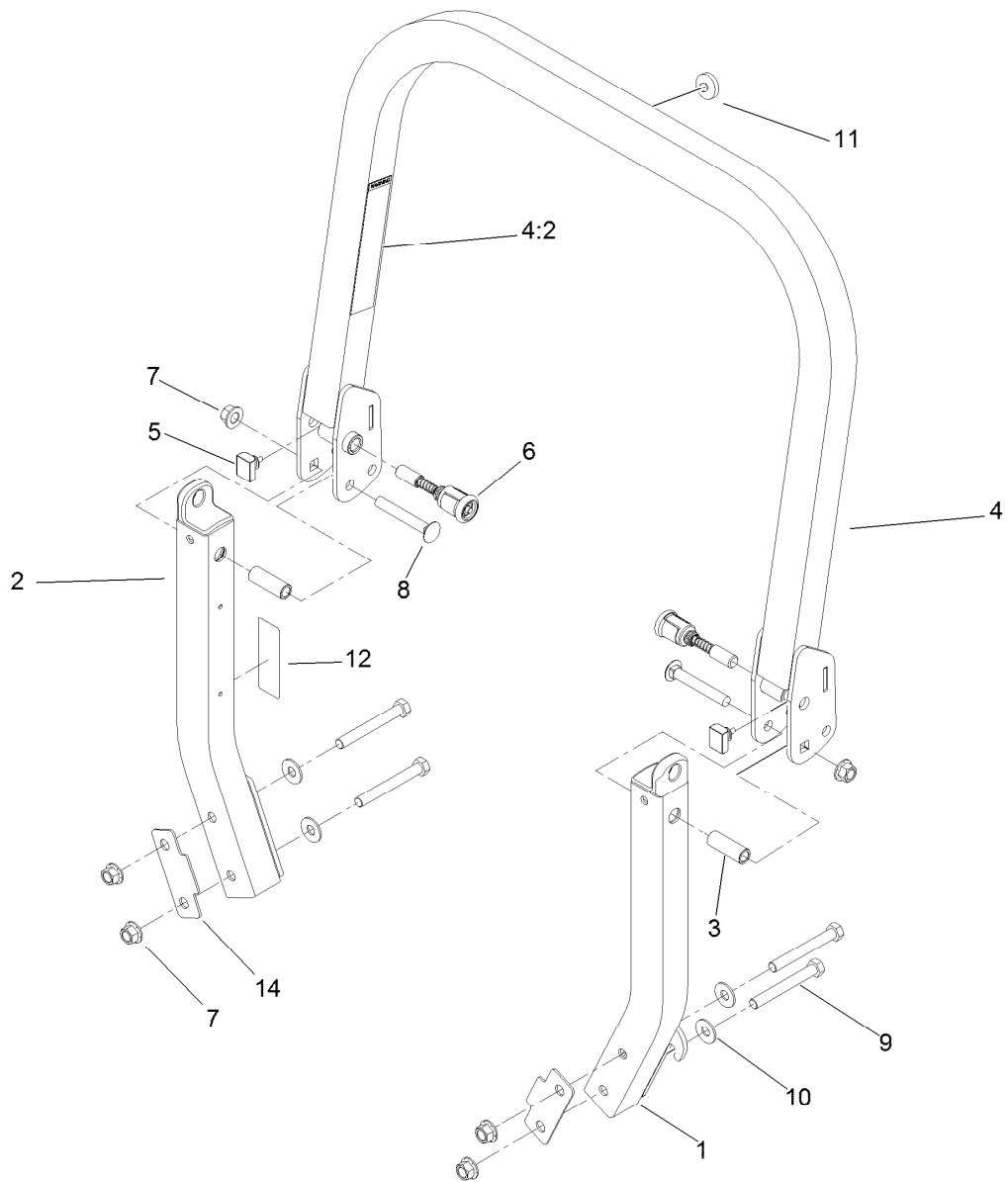

## Roll-Over Protection System Assembly No. 116-0231

Ref.	Part Number	Qty.	Description
1		1	LH ROPS Leg ASM ●
2		1	RH ROPS Leg ASM ●
3	109-6653	2	Spacer
4		1	Upper ROPS ASM ●
4:2	107-2102	1	Decal-Warning, Folding ROPS
5	109-5337	2	Bumper-ROPS
6	116-0104	2	Spring Pin ASM
7	99-5107	6	Nut-Lock
8	3233-10	2	Screw-CARR
9	325-17	4	Screw-HH
10	109-9505	4	Washer-Spring
11	109-9233	1	Bumper-Push-In, Rubber
12	116-0090	1	Decal-Caution
14	116-0960	2	Spacer

● Not serviced separately

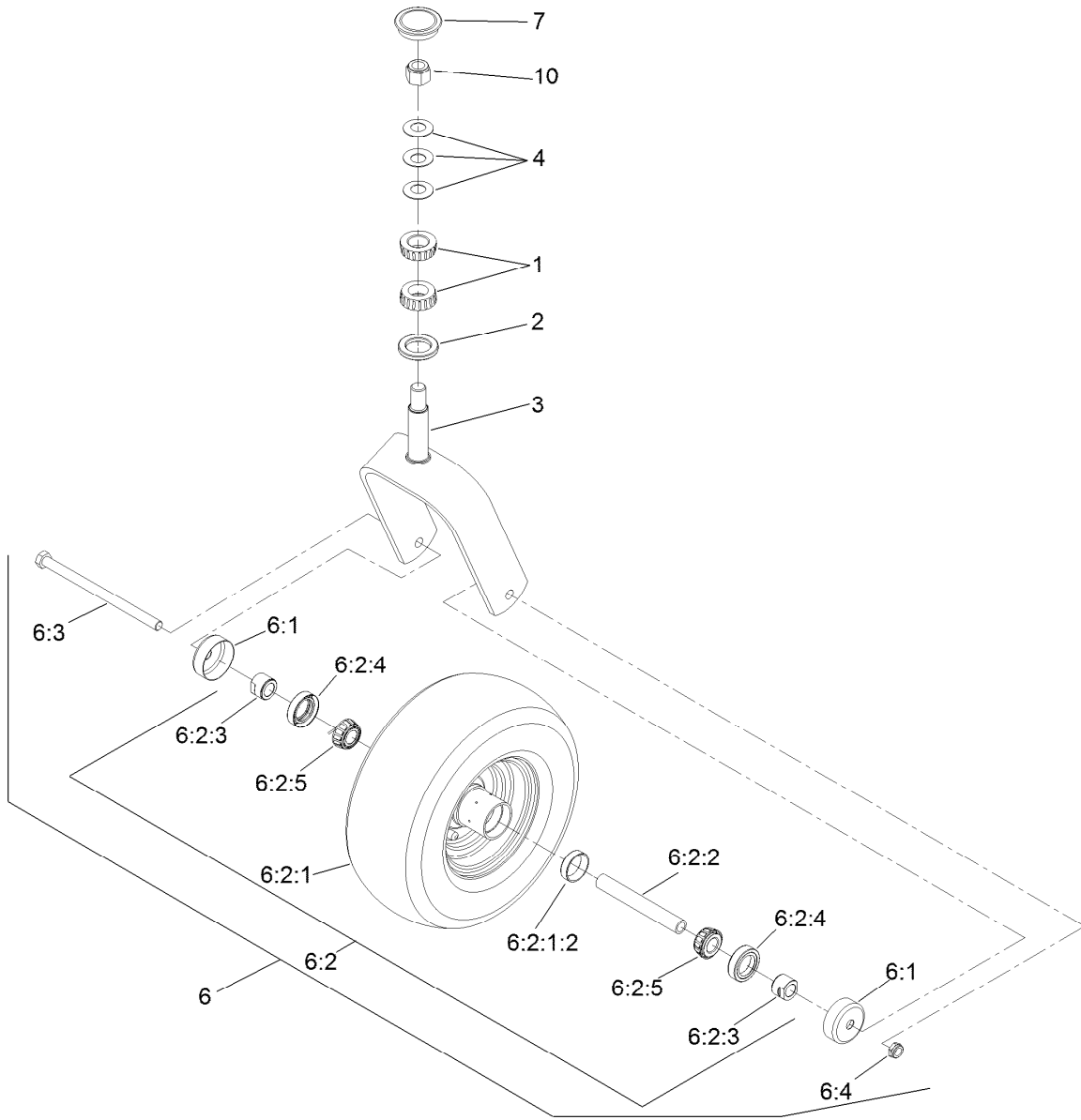

## Caster Wheel and Fork Assembly

Ref.	Part Number	Qty.	Description
1	1-543509	2	Bearing-Roller, Tapered
2	1-543511	1	Seal-Grease
3	109-9422-01	1	Fork-Caster
4	1-633508	3	Washer-Bellville
6	117-0362	1	Castor Wheel ASM
6:1	103-2768	2	Guard-Seal
6:2		1	Wheel And Bearing ASM ●
6:2:1		1	Wheel And Tire ASM ●
6:2:1:2	1-633584	2	Bearing-Cup

Ref.	Part Number	Qty.	Description
6:2:2	103-3155	1	Axle-Caster
6:2:3	103-3051	2	Spacer-Nut
6:2:4	103-0063	2	Seal-Caster
6:2:5	1-633585	2	Bearing-Cone, Taper
6:3	325-36	1	Screw-HH
6:4	3296-45	1	Nut-Lock, NI
7	103-4882	1	Cap-Grease
10	3296-51	1	Nut-Lock, NI

● Not serviced separately

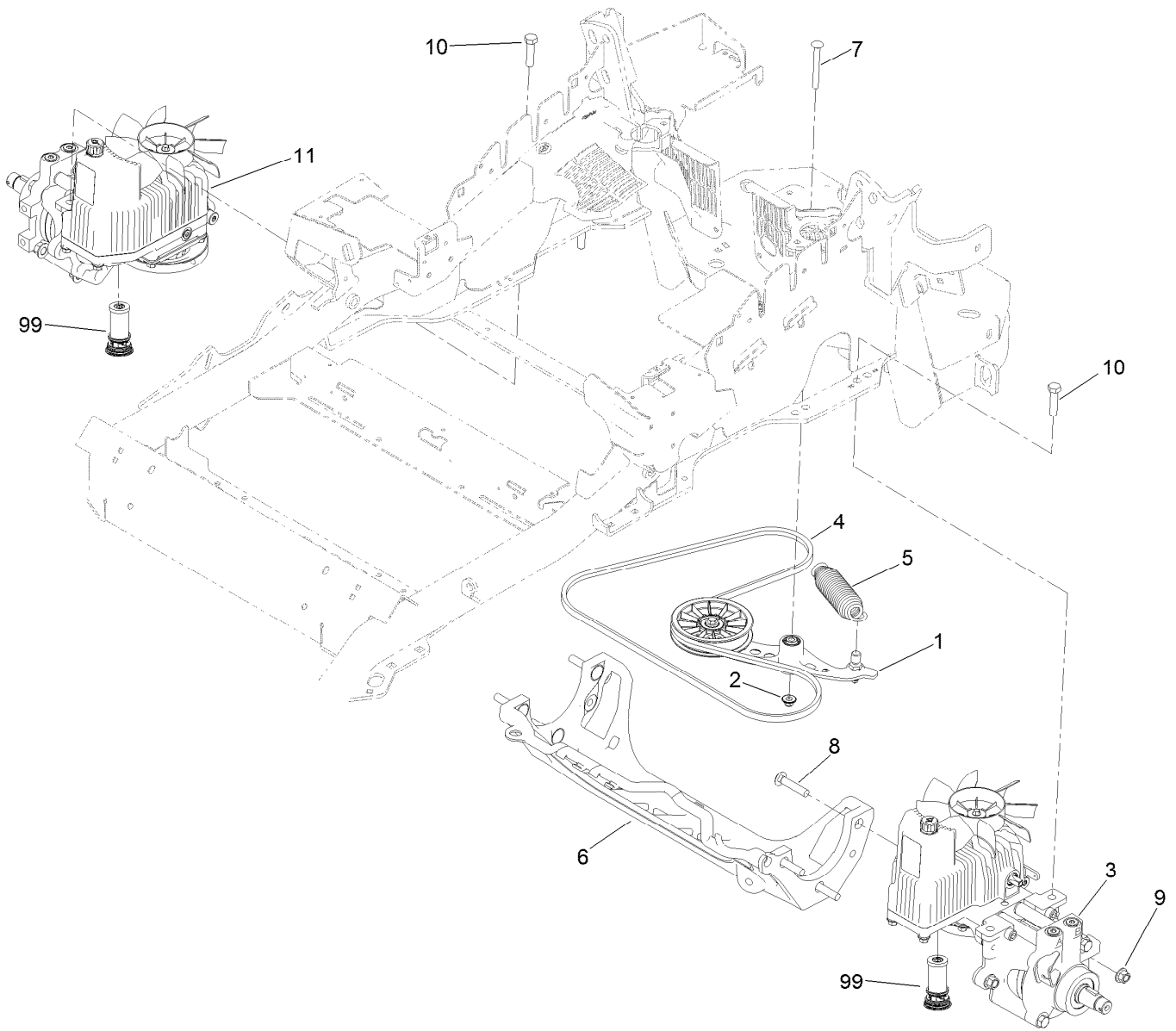

## Hydraulic Pump, Idler and Belt Assembly

Ref.	Part Number	Qty.	Description
1	116-1255	1	Pump Idler ASM
2	109-6658	1	Nut-Flange, NI
3	116-6417	1	LH Hydro 12Cc No Fan
4	116-1953	1	Belt-V
5	116-0133	1	Extension-Spring
6	109-9375	1	Cradle-Hydro
7	116-1502	1	Bolt-Shoulder, Carriage
8	3233-34	6	Screw-CARR
9	99-5107	6	Nut-Lock
10	325-8	4	Screw-HH
11	116-6418	1	RH Hydro 12Cc No Fan
99	114-4713	1	Hypr-Oil 500 (Quart) ●
99	114-4714	1	Hypr-Oil 500 (Gallon) ●
99	114-4715	1	Hypr-Oil 500-5 (5 Gallon) ●
99	117-0390	1	Filter-Hydro

● Not illustrated

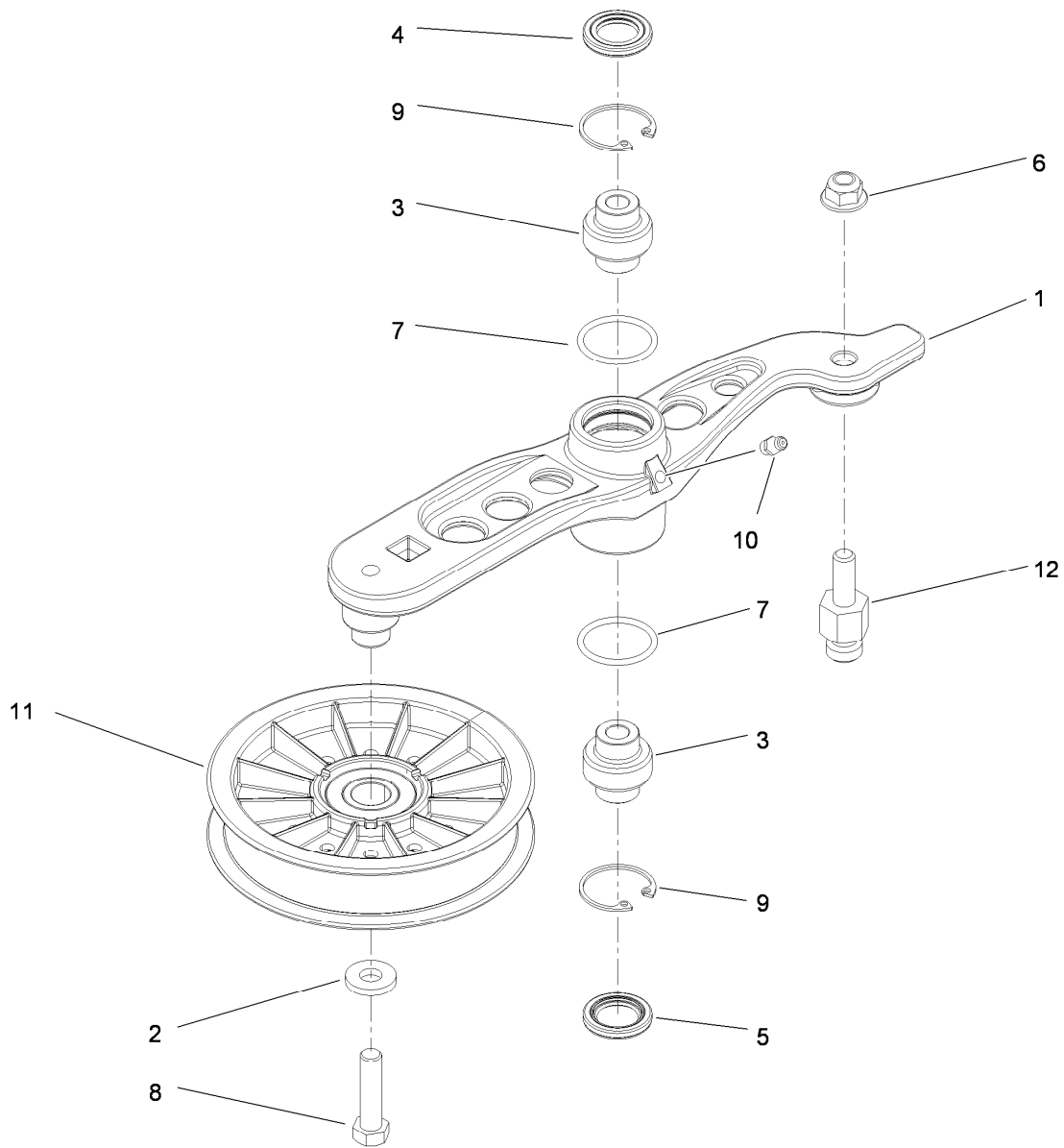

## Pump Idler Assembly No. 116-1255

Ref.	Part Number	Qty.	Description
1		1	Arm-Pump, Idler ●
2	43-0940	1	Spacer
3	103-3504	2	Bearing-Spherical
4	103-3505	1	Seal-Double Lip
5	103-3506	1	Seal-Single Lip
6	109-6658	1	Nut-Flange, NI
7	106-7159	2	O-Ring
8	323-8	1	Screw-HH
9	32120-10	2	Ring-Snap
10	302-19	1	Fitting-Grease
11	109-8076	1	Pulley-Idler
12	116-3467	1	Pin-Spring, Anchor

● Not serviced separately

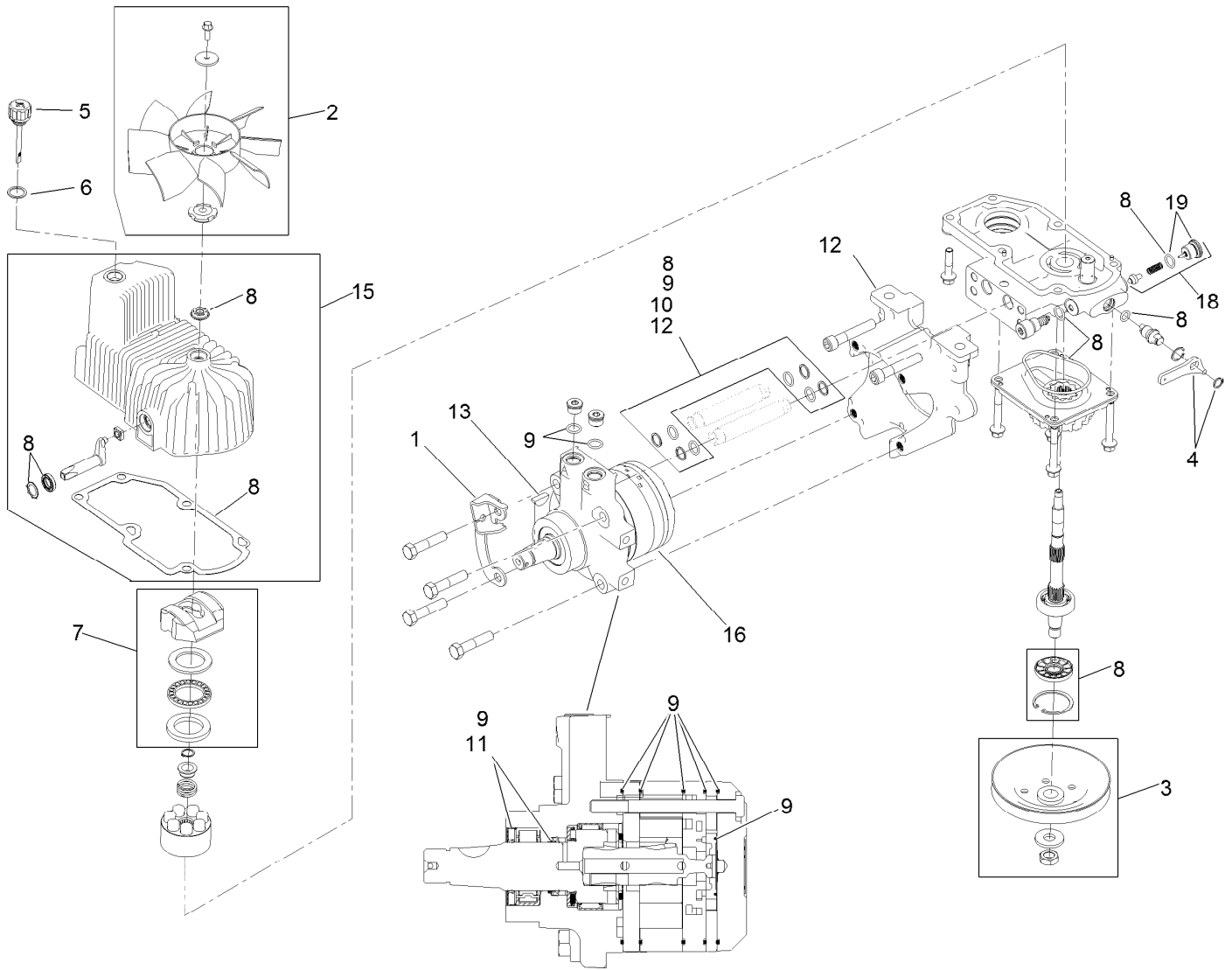

## LH Hydro Assembly No. 116-6417

Ref.	Part Number	Qty.	Description	Ref.	Part Number	Qty.	Description
1	116-6859	1	Bracket-Anchor, Cable	10	116-1370	1	Tube Seal Kit
2	116-3052	1	Cover-Shaft, Hydro	11	116-1371	1	Output Shaft Seal Kit
3	116-0234	1	Pulley Kit	12	116-5469	1	Nose Cup-Uht
4	116-0235	1	Handle-Bypass Valve, Hydro	13	3257-42	1	Key-Woodruff
5	116-0236	1	Dipstick-Hydro W/Gasket	15	116-3287	1	Housing-Hydro, LH
6	116-0237	1	Gasket-Dipstick, Hydro	16	116-5465	1	Motor-Hydraulic LH 240Cc
7	116-1367	1	Swash Block Kit	18	116-1630	1	Check Valve ASM
8	116-1368	1	Pump Seal Kit	19	116-1631	1	Plug-Check, W/O-Ring
9	116-1369	1	Motor Seal Kit	99	116-1373	1	Flow Test Kit ●

● Not illustrated

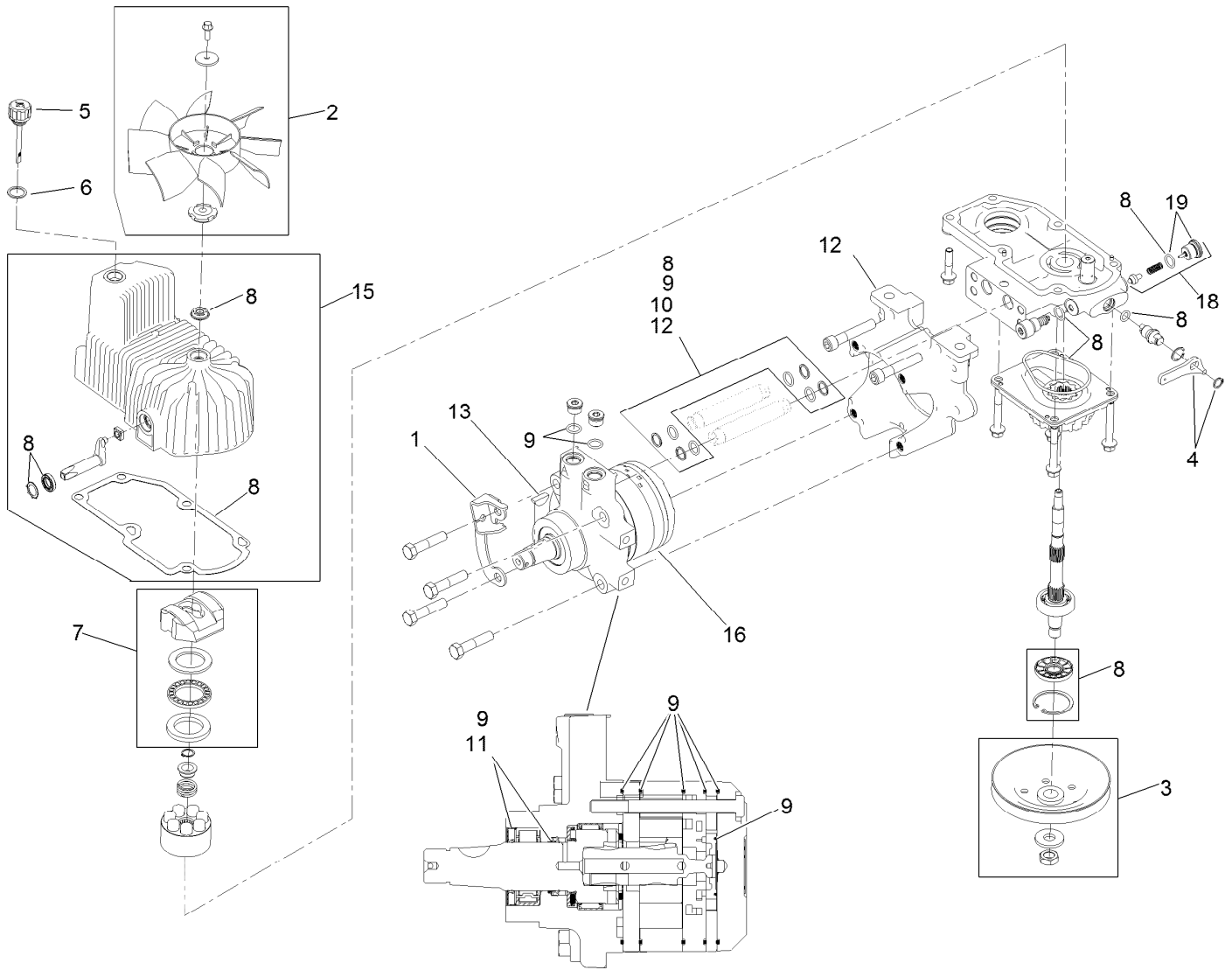

## RH Hydro Assembly No. 116-6418

Ref.	Part Number	Qty.	Description	Ref.	Part Number	Qty.	Description
1	116-6859	1	Bracket-Anchor, Cable	10	116-1370	1	Tube Seal Kit
2	116-3052	1	Cover-Shaft, Hydro	11	116-1371	1	Output Shaft Seal Kit
3	116-0234	1	Pulley Kit	12	116-5469	1	Nose Cup-Uht
4	116-0235	1	Handle-Bypass Valve, Hydro	13	3257-42	1	Key-Woodruff
5	116-0236	1	Dipstick-Hydro W/Gasket	15	116-3288	1	Housing-Hydro, RH
6	116-0237	1	Gasket-Dipstick, Hydro	16	116-5466	1	Motor-Hydraulic RH 240Cc
7	116-1367	1	Swash Block Kit	18	116-1630	1	Check Valve ASM
8	116-1368	1	Pump Seal Kit	19	116-1631	1	Plug-Check, W/O-Ring
9	116-1369	1	Motor Seal Kit	99	116-1373	1	Flow Test Kit ●

● Not illustrated

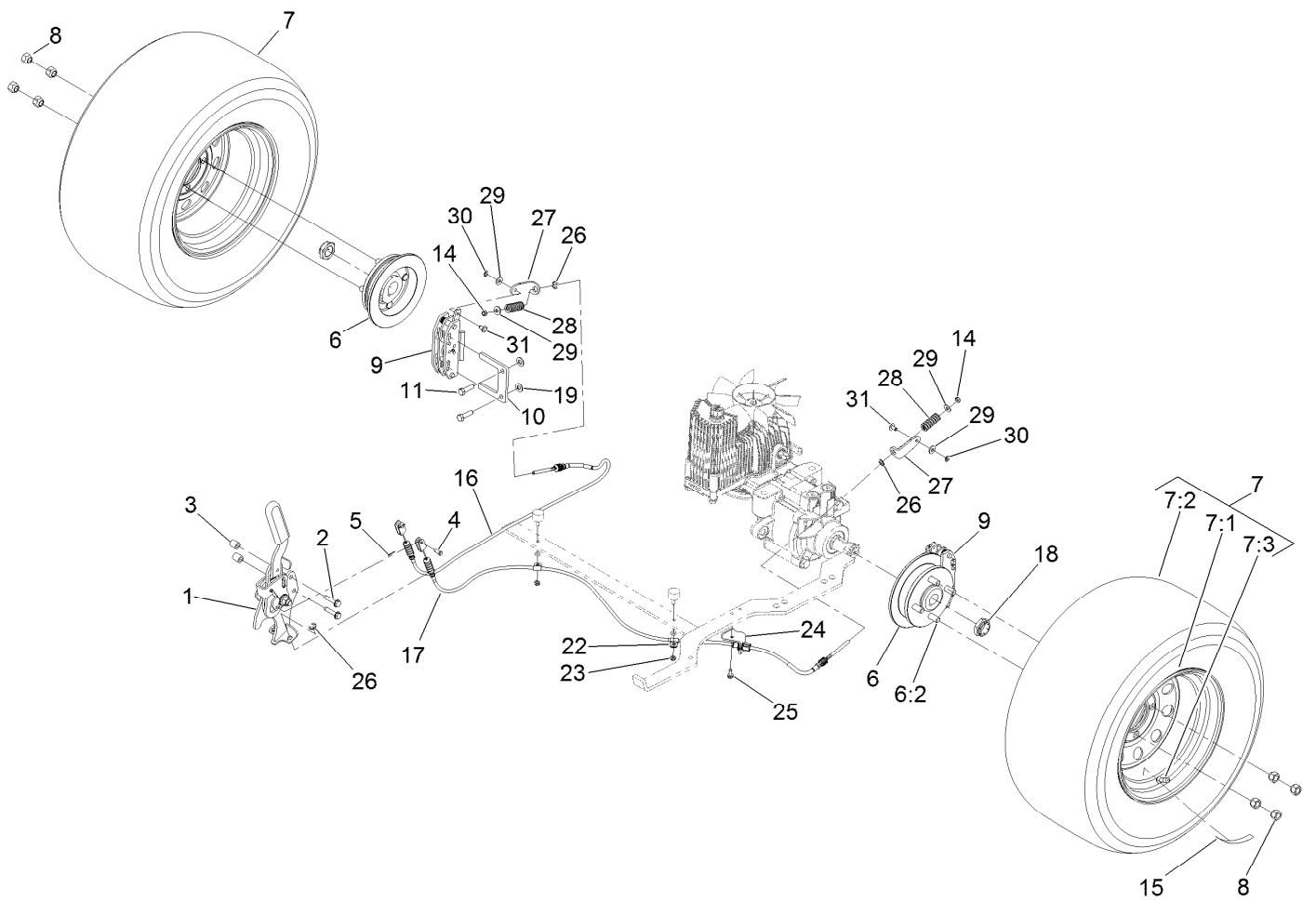

## Rear Wheel and Park Brake Assembly

Ref.	Part Number	Qty.	Description	Ref.	Part Number	Qty.	Description
1	116-6861	1	Brake Handle ASM	15	116-2643	2	Decal-Wheel Nut Torque
2	32144-57	2	Screw	16	116-6364	1	Cable-Park Brake, RH
3	82-6840	2	Spacer	17	116-6365	1	Cable-Park Brake, LH
4	60-1730	2	Pin-Clevis	18	116-1399	2	Locknut
5	3272-1	2	Pin-Cotter	19	3256-24	4	Washer-Flat
6	116-1746	2	Wheel Hub ASM	22	88-7970	2	Clip
6:2	116-1696	4	Stud-Wheel	23	3296-56	2	Nut-Lock, NI
7	115-3589	2	Wheel And Tire ASM	24	116-6397	1	Bracket, Cable
7:1	109-2875	1	Rim ASM	25	32144-10	1	Screw-HWH
7:2	1-653160	1	Tire	26	32120-18	4	E-Ring
7:3	232-27	1	Stem-Valve	27	116-6182	2	Bracket-Brake-L
8	242-50	8	Nut-Lug	28	116-6347	2	Spring-Die
9	109-2889	2	Caliper-Brake	29	3256-22	4	Washer-Flat
10	109-0958	2	Plate-Mount, Brake	30	32151-86	2	E-Ring
11	92-5727	4	Screw-Lock, Patch	31	116-6348	2	Pin-Brake
14	3296-13	2	Nut-Lock, NI				

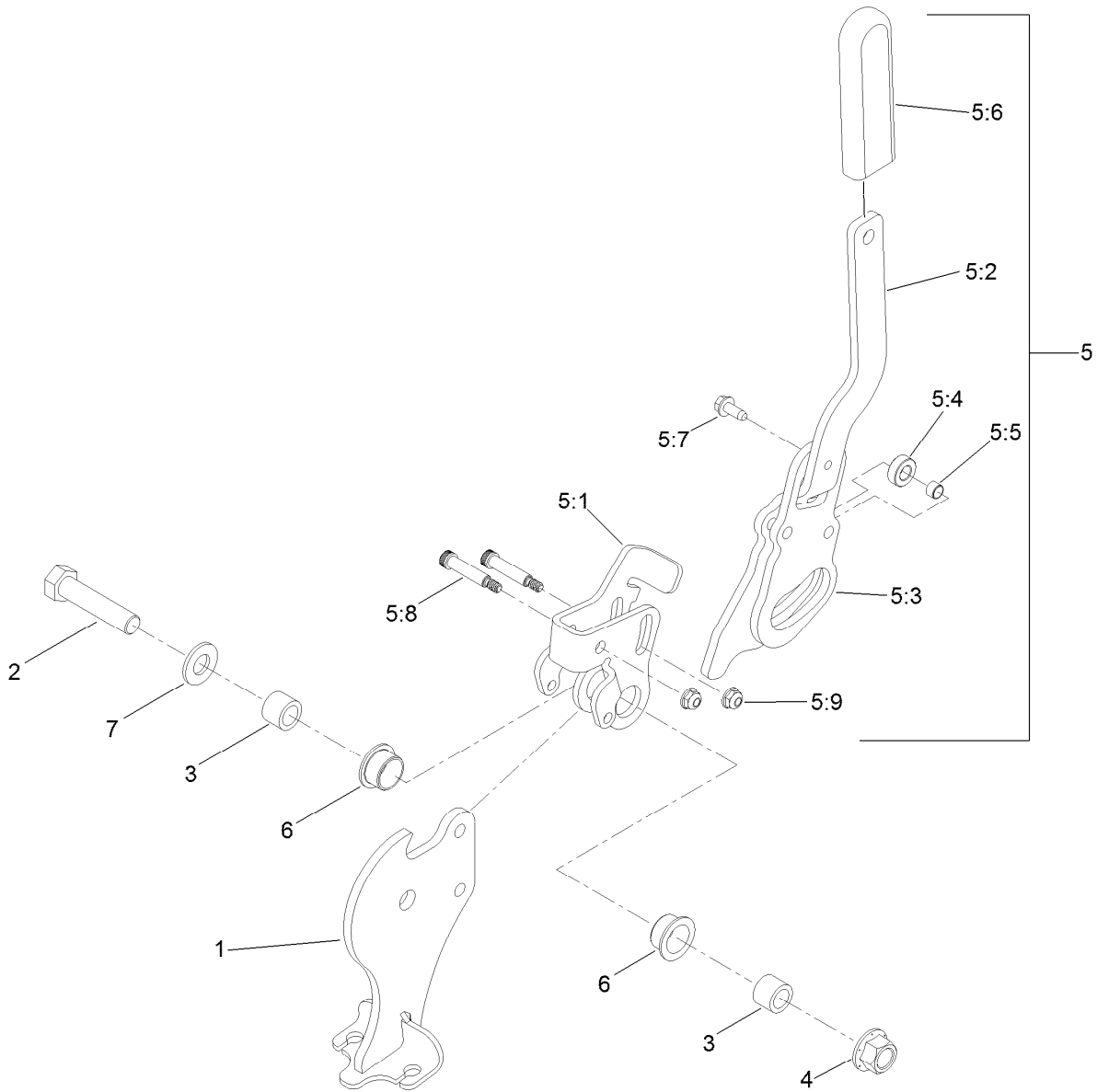

## Parking Brake Handle Assembly No. 116-6861

<i>Ref.</i>	<i>Part Number</i>	<i>Qty.</i>	<i>Description</i>
1	116-6855	1	Brake Pivot ASM
2	325-9	1	Screw-HH
3	116-5384	2	Spacer
4	99-5107	1	Nut-Lock
5	116-6860	1	Handle ASM
5:1	116-6856	1	Bellcrank-Brake
5:2	116-6857	1	Handle-Brake
5:3	116-6858	1	Plate-Handle

<i>Ref.</i>	<i>Part Number</i>	<i>Qty.</i>	<i>Description</i>
5:4	116-6846	1	Roller-Brake
5:5	116-6852	1	Bearing-Sleeve
5:6	1-633268	1	Grip-Lever
5:7	32144-10	1	Screw-HWH
5:8	116-6876	2	Screw-Shoulder
5:9	104-7201	2	Nut-HF
6	109-8054	2	Bushing-Flange
7	3256-26	1	Washer-Flat

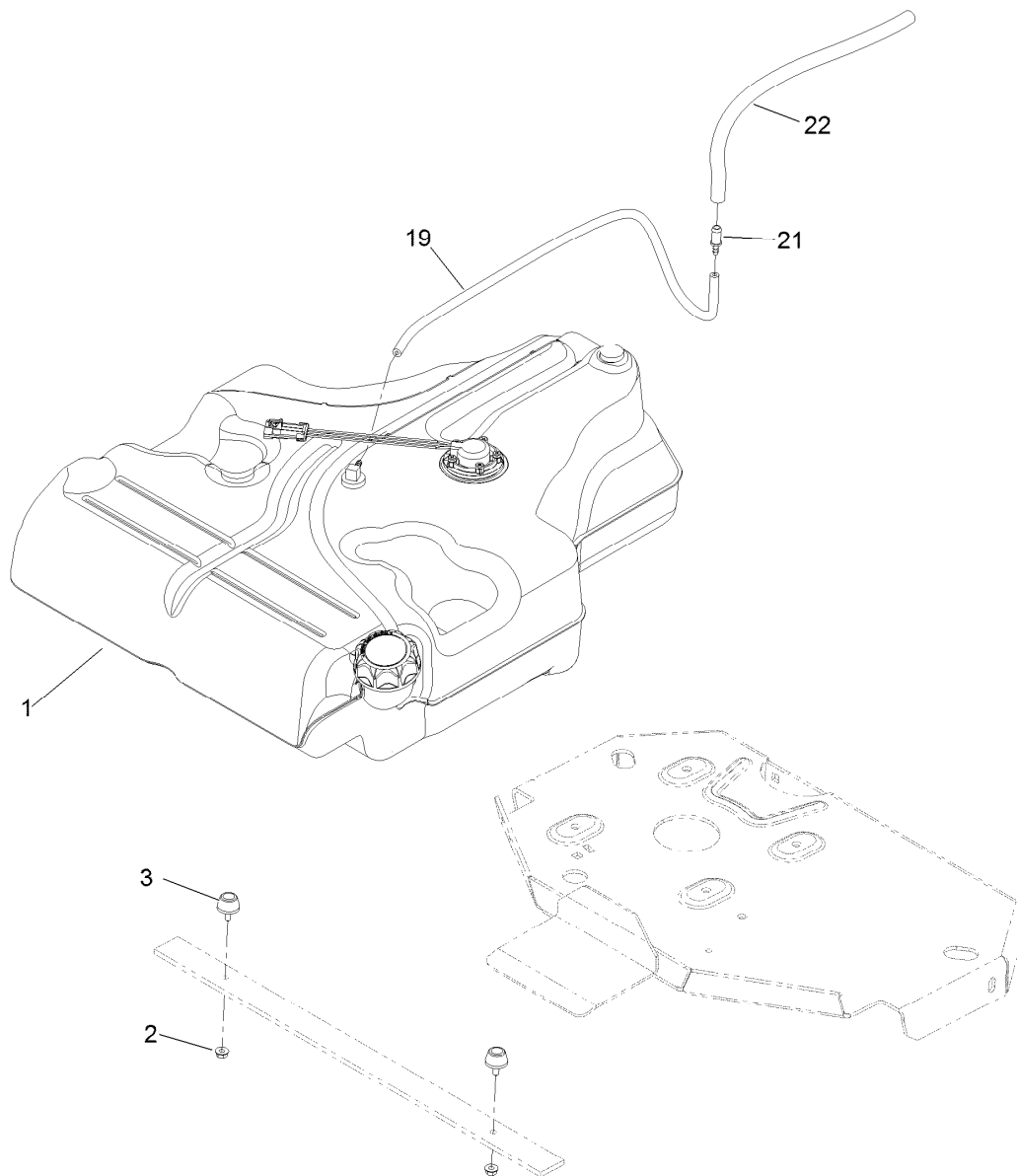

## Fuel Tank Mounting Assembly

<i>Ref.</i>	<i>Part Number</i>	<i>Qty.</i>	<i>Description</i>
1	116-3978	1	Fuel Tank ASM
2	3218-1	2	Nut-Jam
3	116-6380	2	Bumper, Rubber, W/ Stud
19	110-8751	1	Hose-Fuel
21	98-2952	1	Fitting-Straight
22	116-4344	1	Hose-Fuel

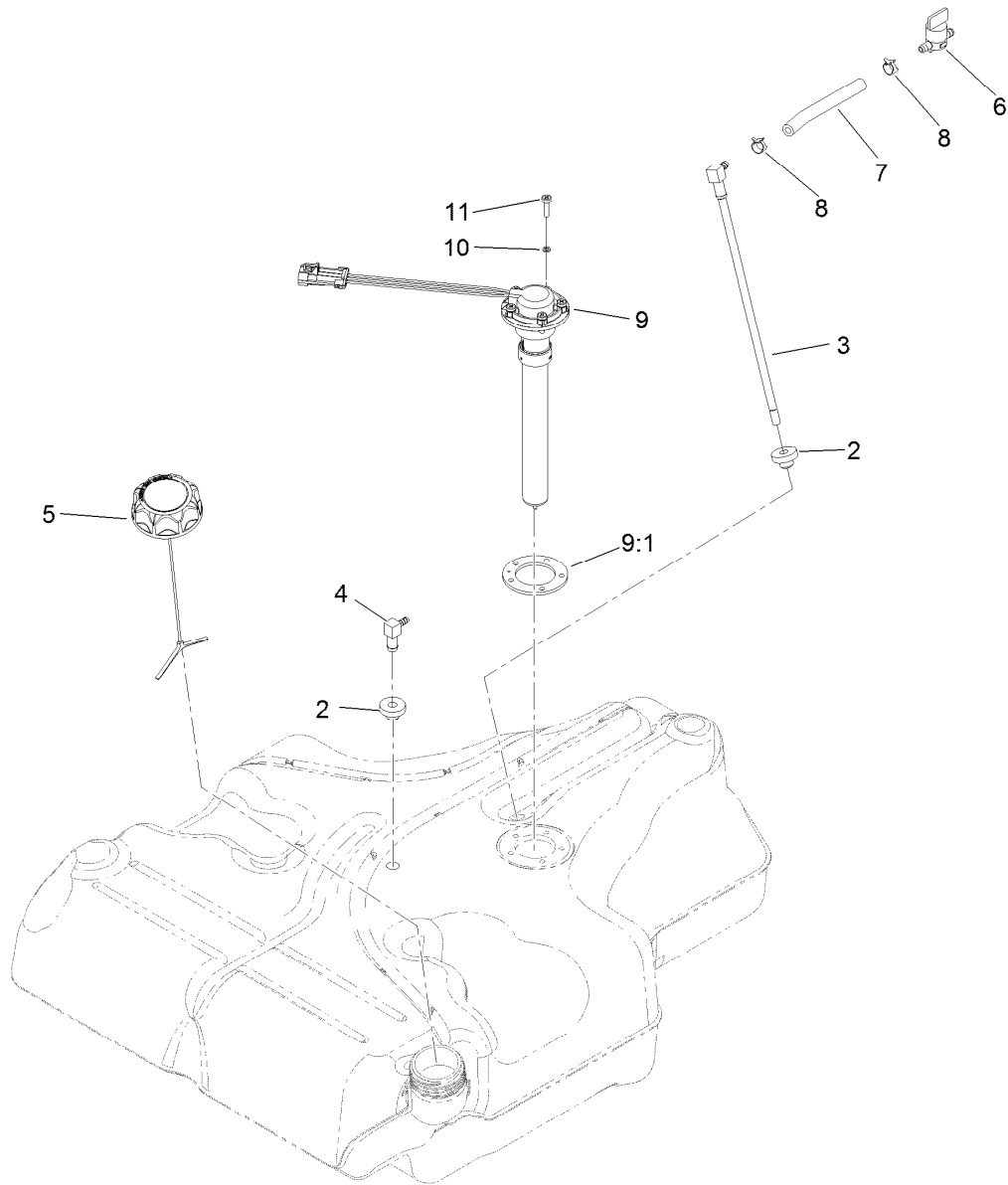

## Fuel Tank Assembly No. 116-3978

Ref.	Part Number	Qty.	Description
2	46-6560	2	Bushing
3	116-2459	1	Fuel Line Kit (With Grommet)
4	116-2288	1	Fitting-90 Elbow, 0.043 Orifice
5	116-1704	1	Cap-Fuel, Ratcheting
6	1-603770	1	Valve-Fuel
7	109-0650	1	Hose-Fuel
8	2412-98	2	Clamp-Hose
9	116-1981	1	Sender-Fuel
9:1	109-9620	1	Gasket-Sender, Fuel
10	3253-17	5	Washer-Lock
11	9107944	5	Screw-Pan

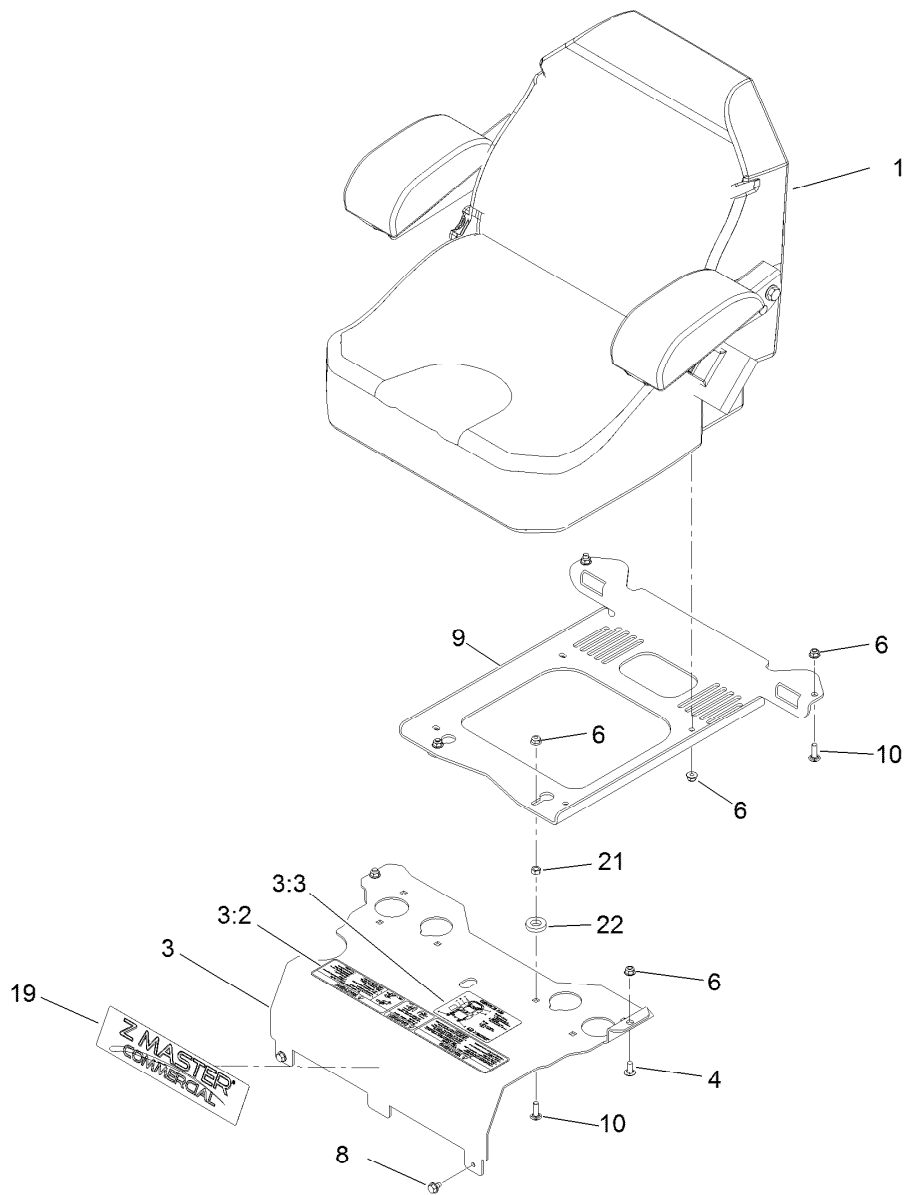

## Seat Mounting Assembly

Ref.	Part Number	Qty.	Description
1	116-0038	1	Seat ASM
3	116-2323	1	Mount-Seat
3:2	109-7069	1	Decal-Console
3:3	116-0211	1	Decal-Service Aid
4	3230-23	2	Screw-CARR
6	104-8300	10	Nut-Flange, NI
8	9266934	2	Screw
9	116-0192-03	1	Plate-Support, Seat
10	3230-22	4	Screw-CARR
19	114-5878	1	Decal
21	3217-6	2	Nut-Hex
22	1-323539	2	Spacer

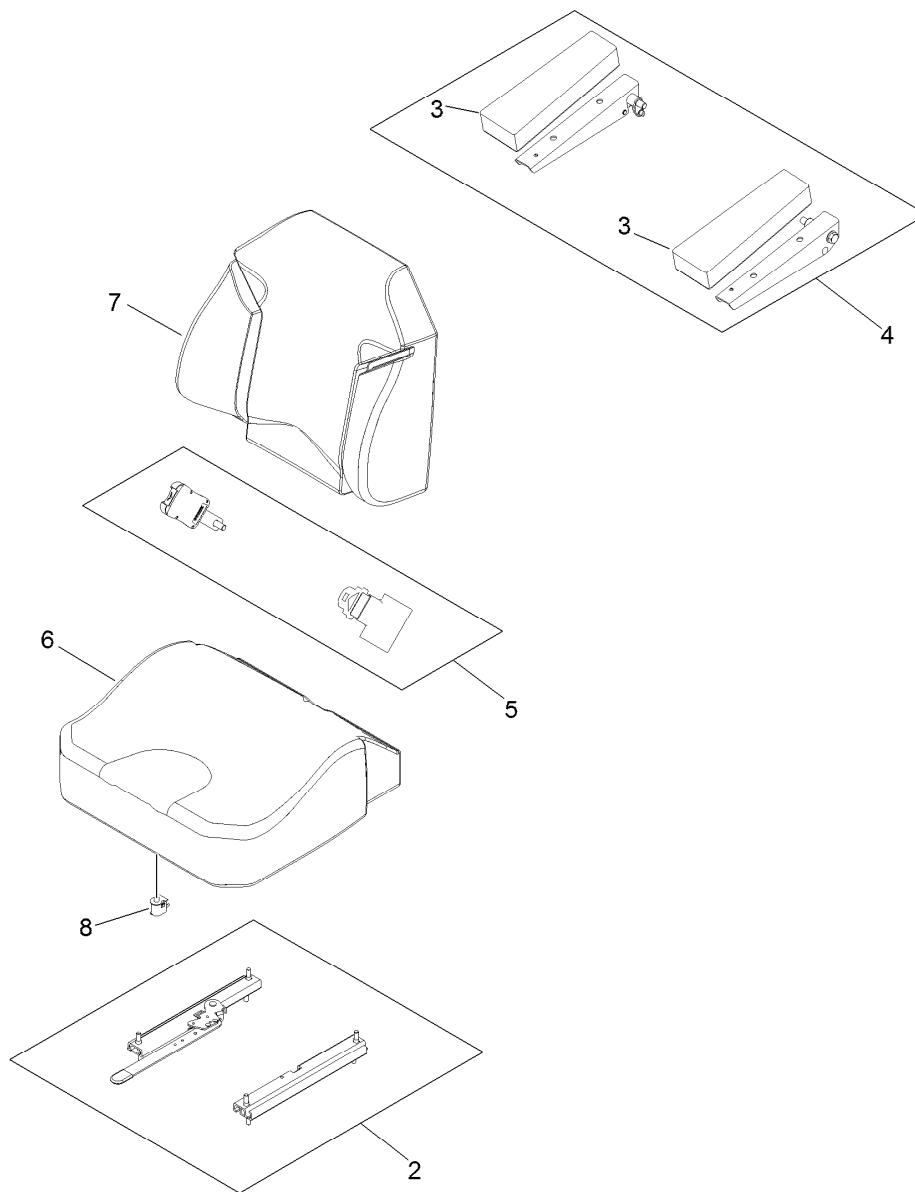

## Seat Assembly No. 116-0038

<i>Ref.</i>	<i>Part Number</i>	<i>Qty.</i>	<i>Description</i>
2	109-9801	1	Seat Track Set
3	109-9814	1	Arm Rest Pads Set
4	109-9816	1	Arm Rest Kit
5	109-9805	1	Seat Belt Kit
6	109-9819	1	Cover-Cushion
7	109-9810	1	Cover-Back
8	82-2190	1	Switch-Bail

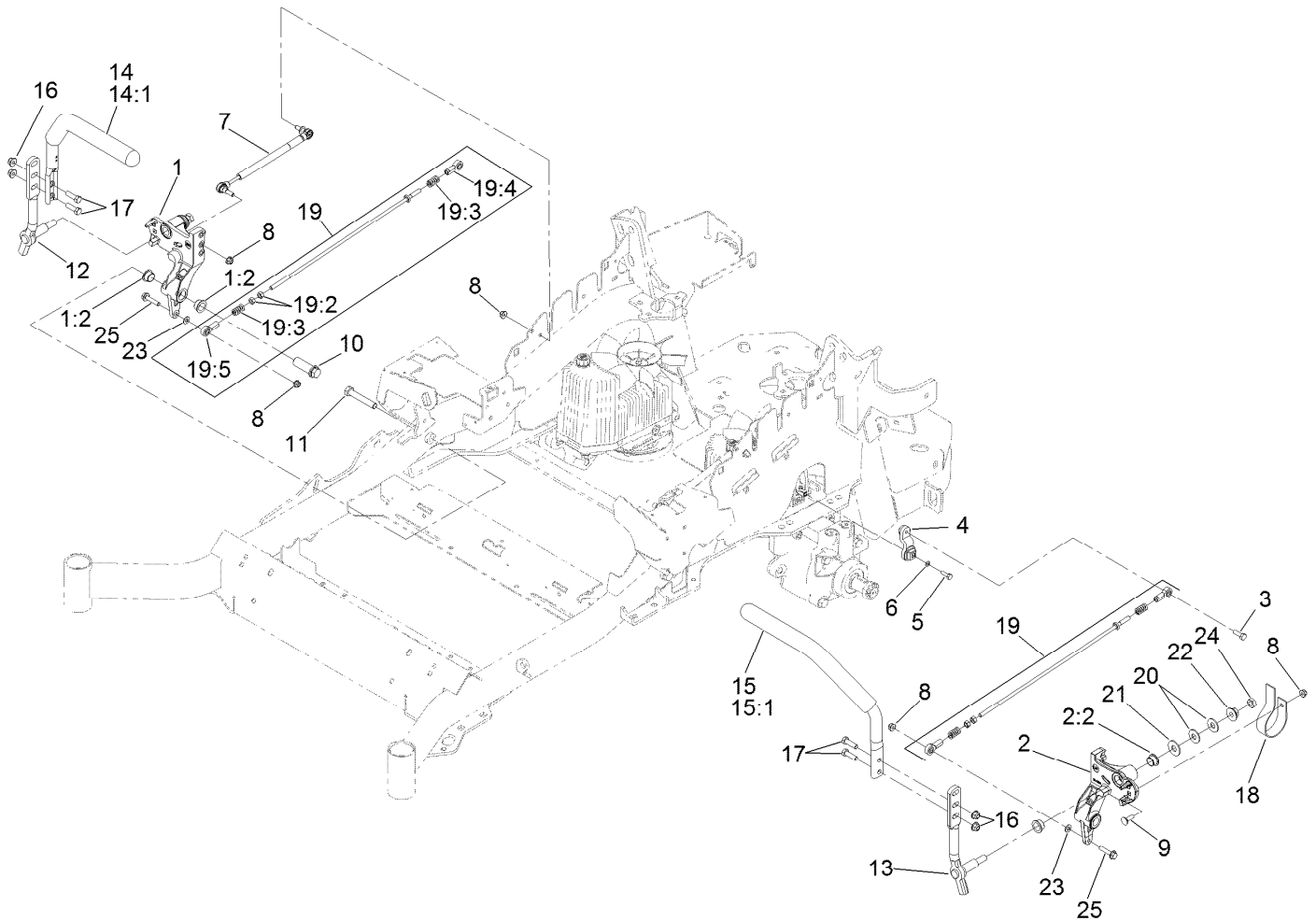

## Motion Control Assembly

Ref.	Part Number	Qty.	Description	Ref.	Part Number	Qty.	Description
1	116-0880	1	RH Motion Control And Bushing ASM	14	109-6591	1	RH Steering Handle ASM
1:2	109-8054	4	Bushing-Flange	14:1	106-9987	1	Grip-Control, Motion
2	116-0881	1	LH Motion Control And Bushing ASM	15	109-6592	1	LH Steering Handle ASM
2:2	109-8054	4	Bushing-Flange	15:1	106-9987	1	Grip-Control, Motion
3	116-0648	2	Screw-HH, Thread Locking ●	16	104-8301	4	Nut-Flange, NI
4	109-4581	2	Arm-Control, Pump	17	323-7	4	Screw-HH
5	9080046	2	Screw-HH ●	18	109-5575	2	Spring-Leaf
6	1-303435	2	Washer-Spring	19	109-8107	2	Pump Linkage Rear ASM
7	116-0027	2	Damper-Control, Motion	19:2	3219-2	2	Nut-Hex
8	104-8300	8	Nut-Flange, NI	19:3	1-323245	2	Spring-Compression
9	3230-2	2	Bolt-CARR	19:4	1-633152	1	Balljoint-LH
10	109-5891	2	Hub-Threaded	19:5	1-543017	1	Balljoint-RH
11	325-12	2	Screw-HH	20	109-9505	4	Washer-Spring
12	116-0039	1	Lever-Control Motion, RH	21	3256-6	2	Washer-Flat
13	116-0040	1	Lever-Control Motion, LH	22	32128-56	2	Nut-HF
				23	3256-23	2	Washer-Flat
				24	3218-5	2	Nut-Jam
				25	115-1794	2	Screw-HHF

● Use Pro-Lock, Nut Type (P/N 1-840022, .5ml tube) on threads.

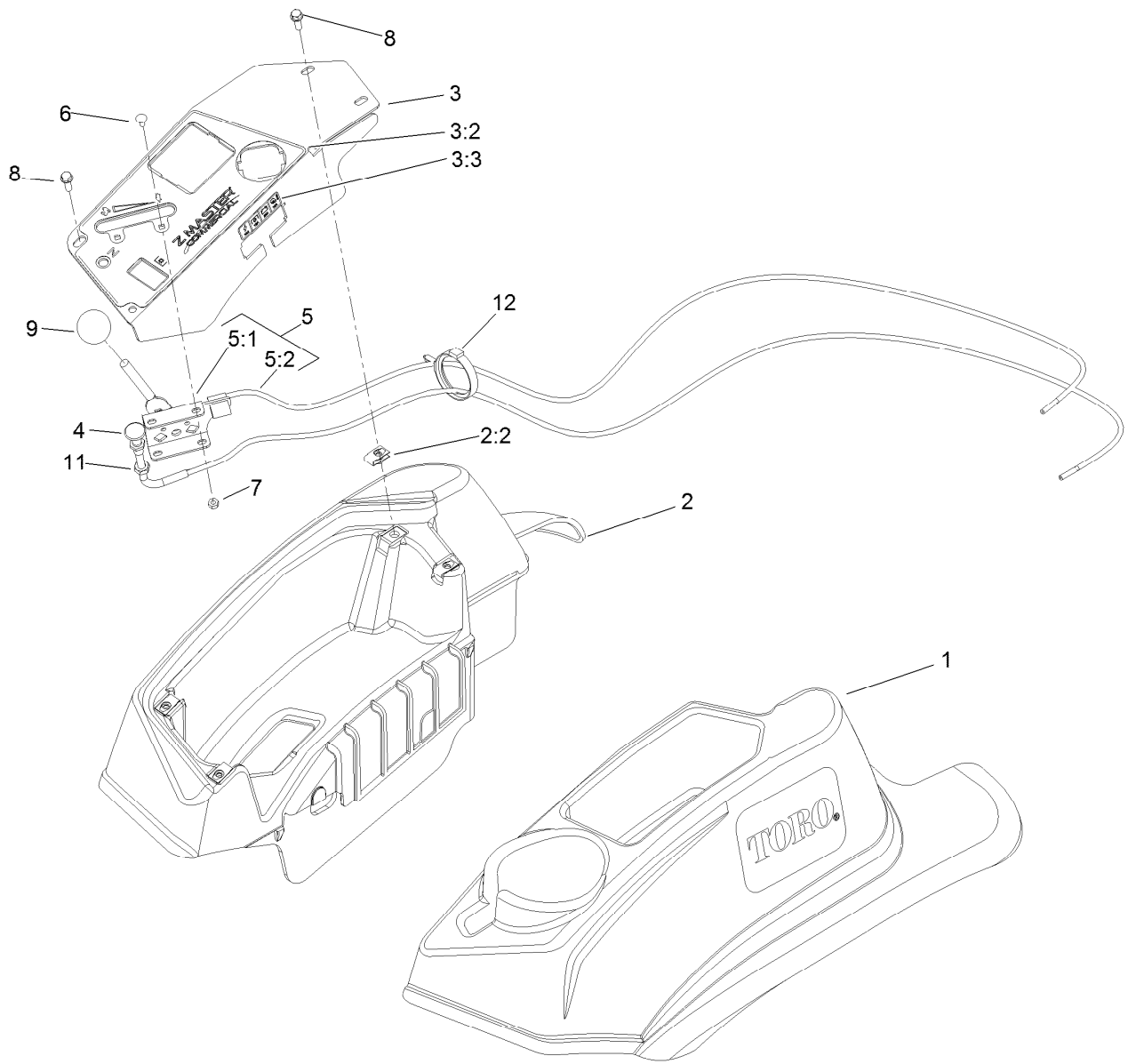

## Fender, Console and Control Assembly

Ref.	Part Number	Qty.	Description
1	119-2602	1	Console-LH
2	119-2603	1	RH Console ASM
2:2	107069	4	Clip
3	119-6663	1	Control Panel ASM
3:2	121-7551	1	Decal-Control Panel
3:3	114-4466	1	Decal-Fuses
4	115-2753	1	Choke Control ASM
5	110-5727	1	Throttle Control ASM

Ref.	Part Number	Qty.	Description
5:1	112-2334	1	Lever-Throttle
5:2	110-5728	1	Cable-Throttle
6	1-807513	2	Bolt-CARR
7	3296-2	2	Nut-Lock, NI
8	32105-15	4	Screw
9	1-603175	1	Knob-Ball
11	3220-3	1	Nut-HJ
12	117-7817	1	Clamp-Harness

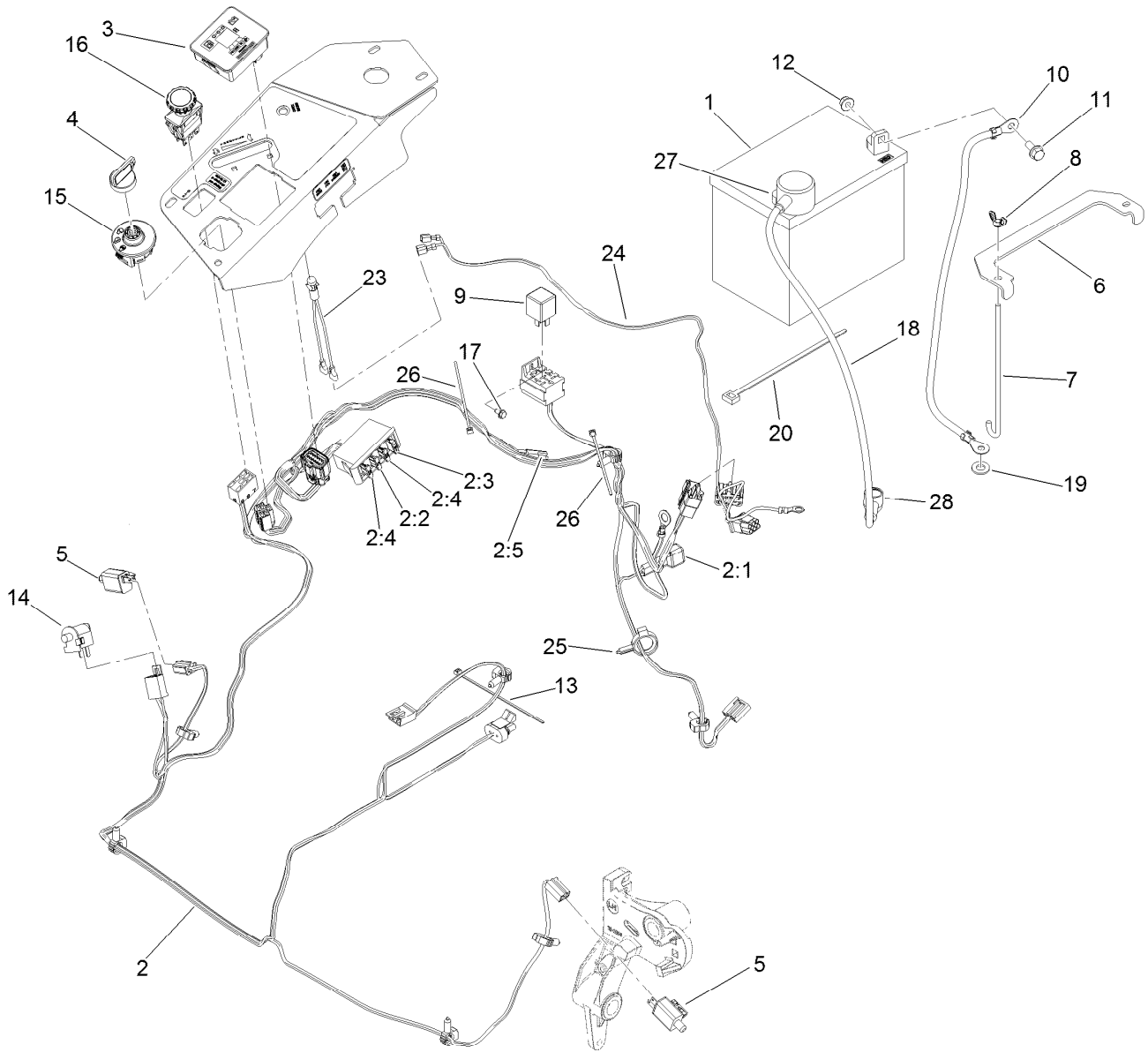

## Electrical System Assembly

Ref.	Part Number	Qty.	Description	Ref.	Part Number	Qty.	Description
1	104-8162	1	Battery	12	104-8300	2	Nut-Flange, NI
2	116-6009	1	Harness-Wire, Main ●	13	1-303287	3	Tie-Cable
2:1	103-3895	1	Diode-Tvs	14	82-2190	1	Switch-Bail
2:2	218-578	1	Fuse-Blade, 10 Amp	15	117-2221	1	Switch-Ignition
2:3	109355	1	Fuse-Blade, 15 Amp	16	116-0124	1	Switch-PTO, 10A
2:4	109102	2	Fuse-Blade, 25 Amp	17	104-2065	1	Screw-HWH
2:5	116-0053	1	Cap-Plug	18	115-3864	1	Cable-Battery, Positive
3	117-3882	1	Fuel/Hour Meter ASM	19	3256-24	1	Washer-Flat
4	63-8360	1	Key-Ignition	20	1-303335	1	Tie-Plastic
5	110-6765	2	Switch-Single Pole No	23	1-643267	1	Indicator-Led, Red
6	116-0042-03	1	Strap-Tie Down, Battery	24	116-3062	1	Harness-Indicator Light
7	1-633651	2	Bolt-Holddown	25	105-1853	1	Clamp-Hose
8	1-543792	2	Wingnut	26	1-303287	2	Tie-Cable
9	1-643275	1	Relay	27	109-2407	1	Insulator-Battery
10	114-1218	1	Cable-Battery, Negative	28	1-543393	1	Insulator-Solenoid
11	3234-5	2	Screw-HHF				

● Use dielectric grease on all unsealed connectors and terminals only. Do not apply in sealed connectors.

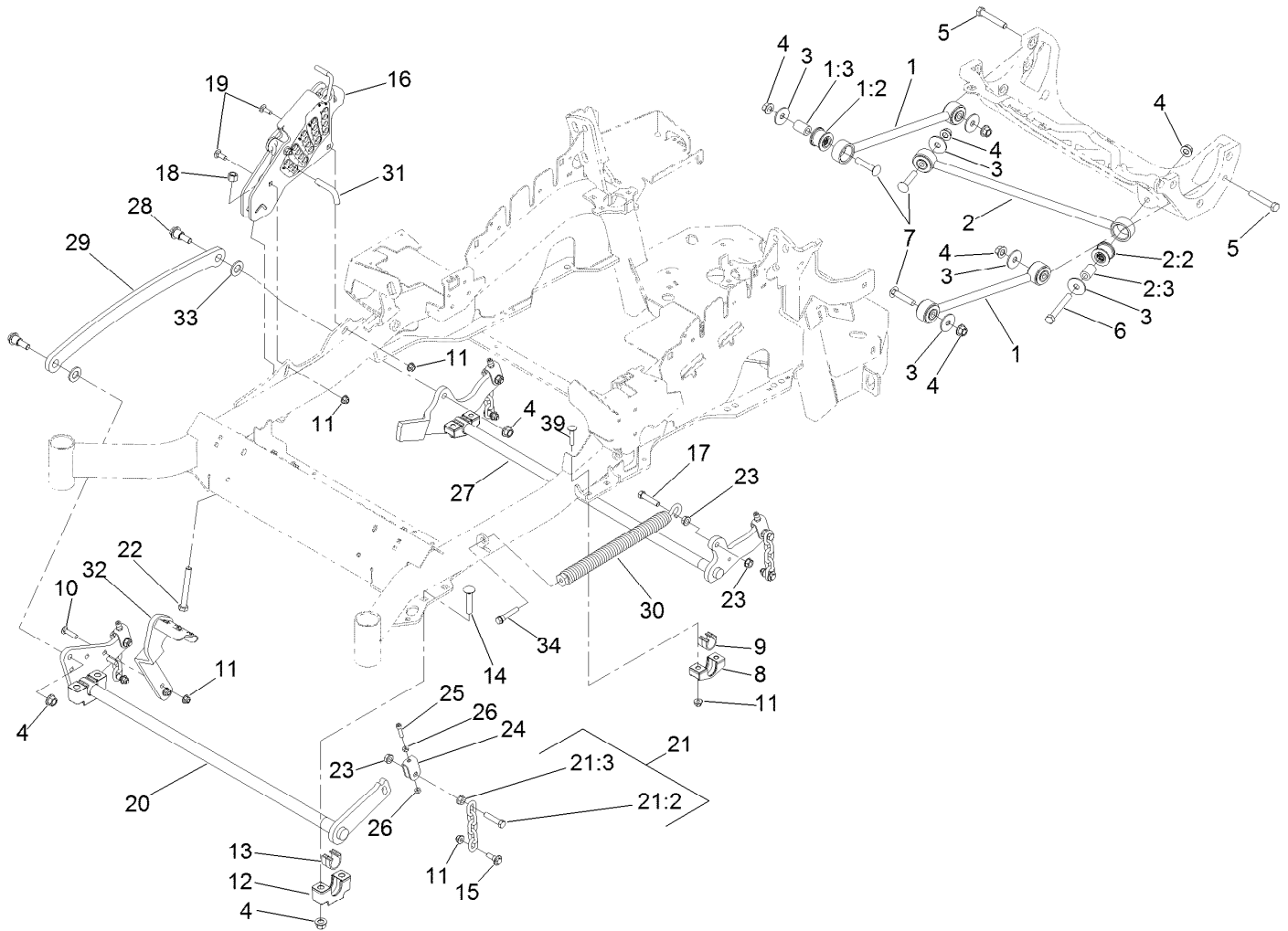

## Decklift Assembly

Ref.	Part Number	Qty.	Description	Ref.	Part Number	Qty.	Description
1	109-7952	2	Deck Strut ASM	14	116-1700	4	Bolt-CARR
1:2	109-5009	2	Bushing-Suspension, Rubber	15	109-9840	4	Screw-Shoulder, HHF
1:3	109-5010	2	Spacer	16	109-7438	1	HOC ASM
2	109-5013	1	Panhard Rod ASM	17	109-9065	1	Screw-HH
2:2	109-5009	2	Bushing-Suspension, Rubber	18	3296-23	1	Nut-Lock, NI
2:3	109-5010	2	Spacer	19	3231-2	2	Screw-CARR
3	86-1990	6	Washer	20	116-2217-03	1	Cross Shaft Front ASM
4	99-5107	12	Nut-Lock	21	116-0756	4	Deck Lift Chain ASM
5	325-12	2	Screw-HH	21:2	109-9065	1	Screw-HH
6	325-17	1	Screw-HH	21:3	32128-37	1	Nut-HF
7	3233-34	3	Screw-CARR	22	116-0559	1	Bolt-TAP
8	116-0818-03	2	Support-Bearing, Cross Shaft Rear	23	32128-37	6	Nut-HF
9	109-7173	2	Bearing-Cross, Rear Shaft	24	109-9066	4	Yoke-Adjust, Deck
10	3231-4	2	Screw-CARR	25	3274-18	4	Screw-HSH
11	104-8301	12	Nut-Flange, NI	26	3218-2	8	Nut-Jam
12	109-9409	2	Support-Cross Shaft, Bearing Front	27	116-0459-03	1	Lift-Deck, Rear
13	109-9410	2	Bearing-Shaft Front, Cross	28	116-0780	2	Screw-HHF, Shoulder
				29	116-0797-03	1	Link-Lift, Deck
				30	116-0886	1	Extension Spring ASM
				31	116-5584	1	Pin-HOC
				32	116-1919-01	1	Lever-Foot

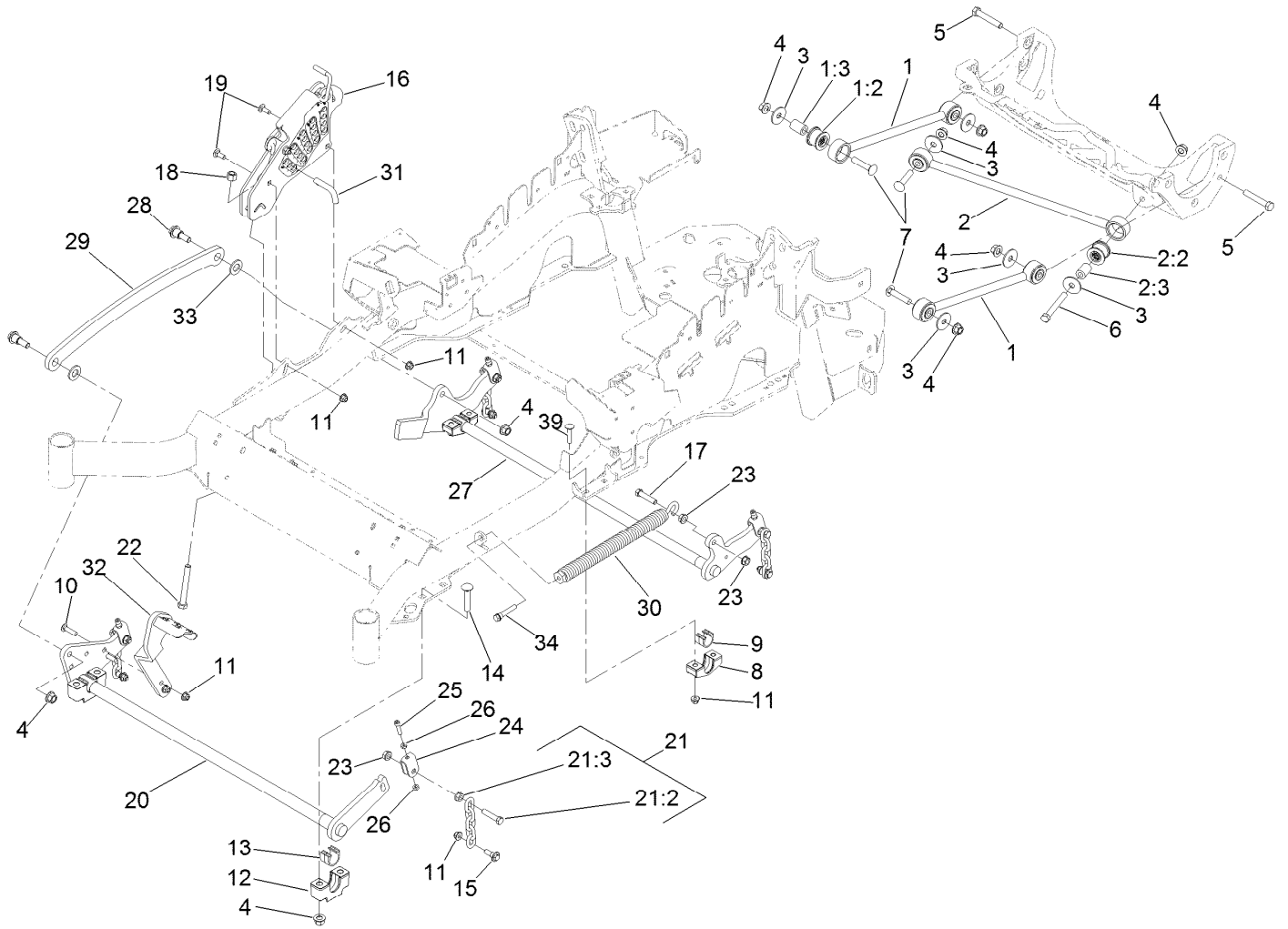

## Decklift Assembly (continued)

<i>Ref.</i>	<i>Part Number</i>	<i>Qty.</i>	<i>Description</i>	<i>Ref.</i>	<i>Part Number</i>	<i>Qty.</i>	<i>Description</i>
33	3256-28	2	Washer-Flat	34	92-7674	1	Bolt-Shoulder
				39	3231-5	4	Screw-CARR

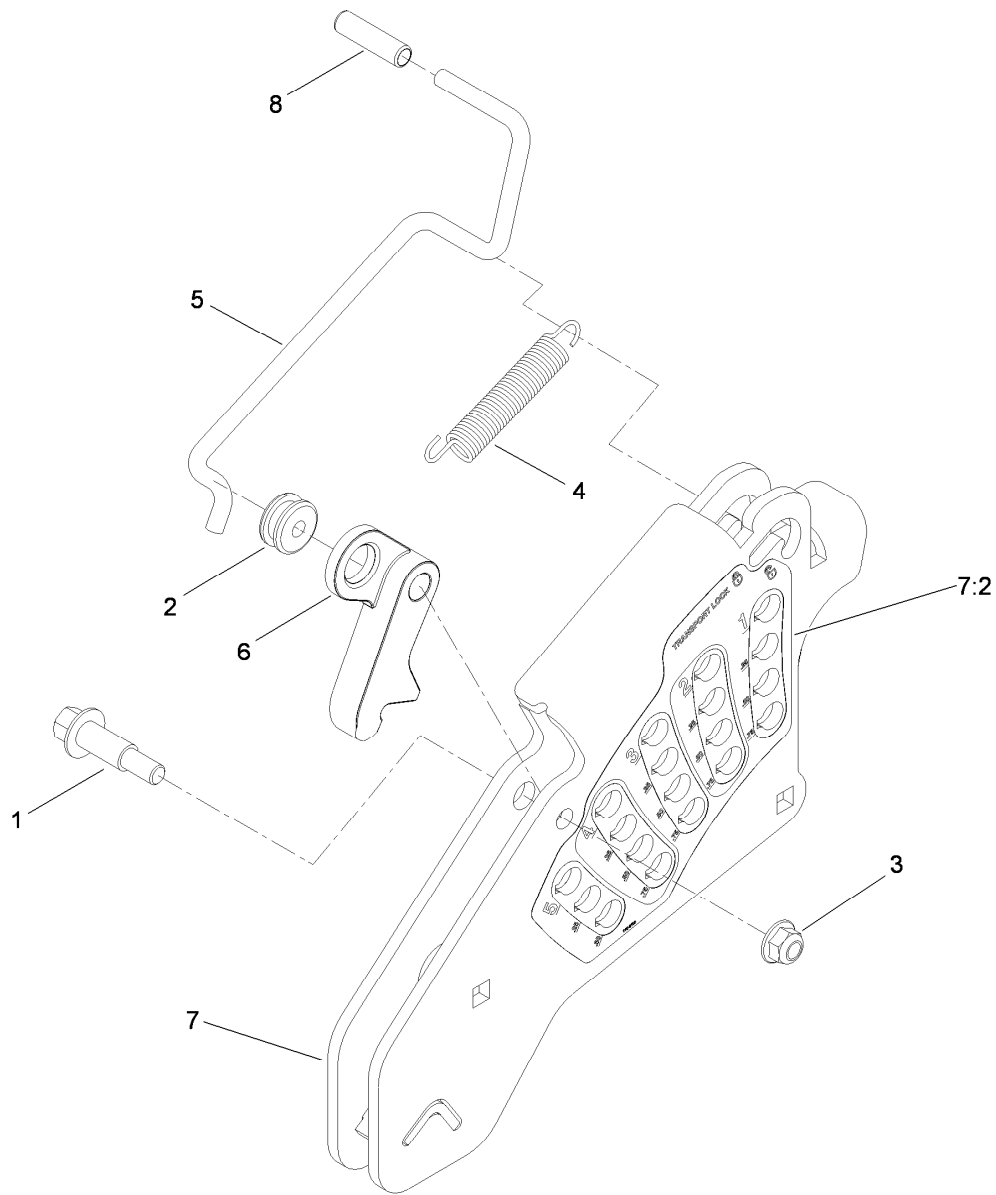

## Height-of-Cut Assembly No. 109-7438

<i>Ref.</i>	<i>Part Number</i>	<i>Qty.</i>	<i>Description</i>
1	62-1330	1	Bolt-Shoulder
2	109-7130	1	Grommet
3	104-8301	1	Nut-Flange, NI
4	109-7124	1	Spring-Extension
5	109-7128	1	Rod-Lock, Transport
6	116-0118	1	Pawl-Transport, HOC
7	109-7335	1	HOC Plate ASM
7:2	116-0752	1	Decal-HOC
8	109-8250	1	Grip-Lever

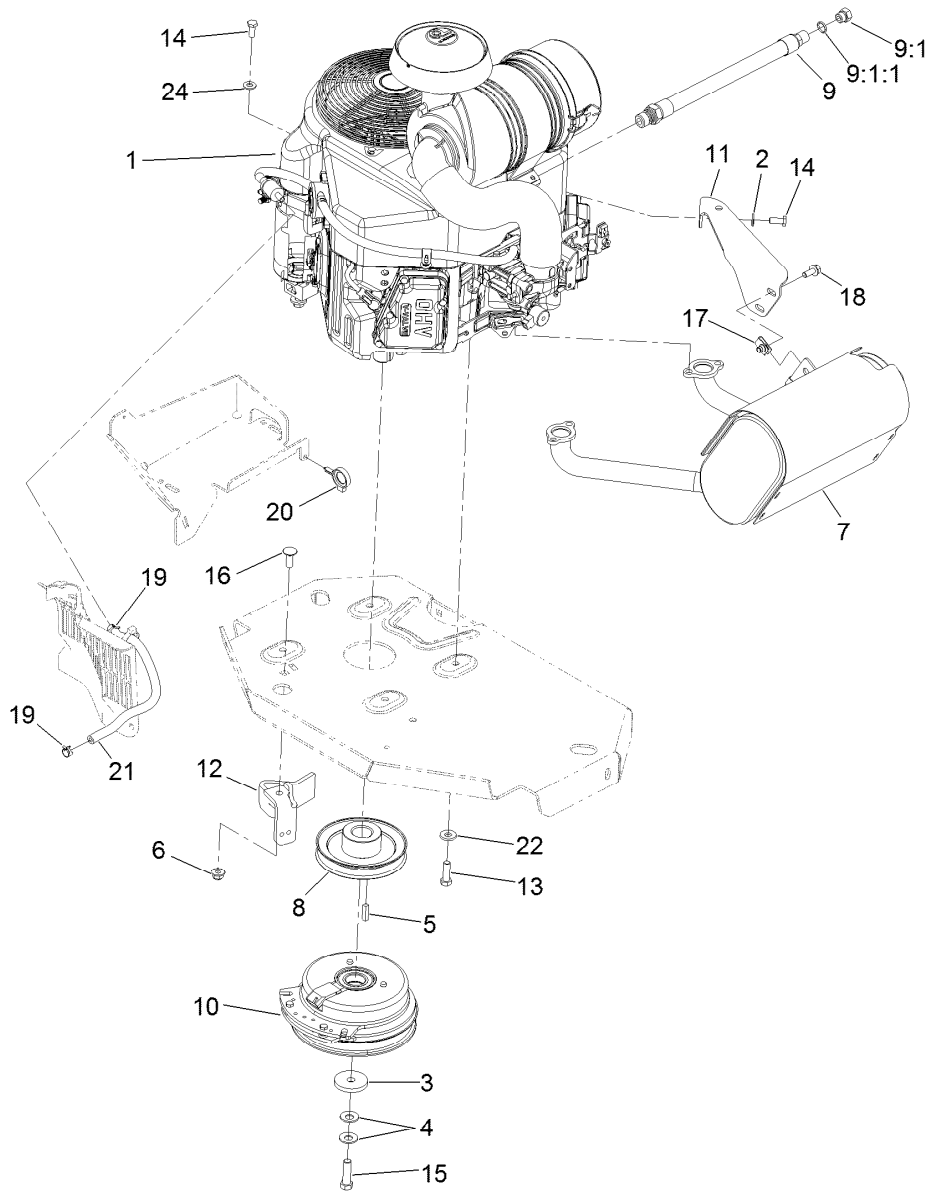

## Engine, Muffler and Clutch Assembly

Ref.	Part Number	Qty.	Description
1		1	Engine-Kawasaki, Fx691V-S17-R ●■
2	1-303334	1	Washer-Spring
3	109-6919	1	Washer-Clutch
4	1-603610	2	Washer-Spring
5	1-807259	1	Key
6	104-8301	1	Nut-Flange, NI
7	116-1715	1	Muffler
8	116-1946	1	Sheave-Pump, Drive
9	116-4924	1	Engine Oil Drain Hose ASM ▲
9:1	353-508	1	Plug-HH
9:1:1	237-42	1	O-Ring
10	116-1947	1	Clutch

Ref.	Part Number	Qty.	Description
11	116-1435	1	Bracket-Muffler
12	116-2612-01	1	Clutch-Anchor
13	323-7	4	Screw-HH
14	33114-020	2	Screw-HH
15	109-9761	1	Screw-HH, W/Loctite ◆
16	3231-22	1	Screw-CARR
17	94-2413	2	U-Nut
18	3234-5	2	Screw-HHF
19	2412-98	2	Clamp-Hose
20	105-1853	1	Clamp-Hose
21	109-0296	1	Hose-Fuel
22	98-5975	4	Washer-Belleville
24	33094-00	1	Washer-Plain

● Not serviced separately

▲ Use a Teflon Pipe Sealant or equivalent on threads.

◆ Use Pro-Lock, Nut Type (P/N 1-840022, .5ml tube) on threads.

■ Obtain parts from [www.kawpowerepc.com](http://www.kawpowerepc.com)

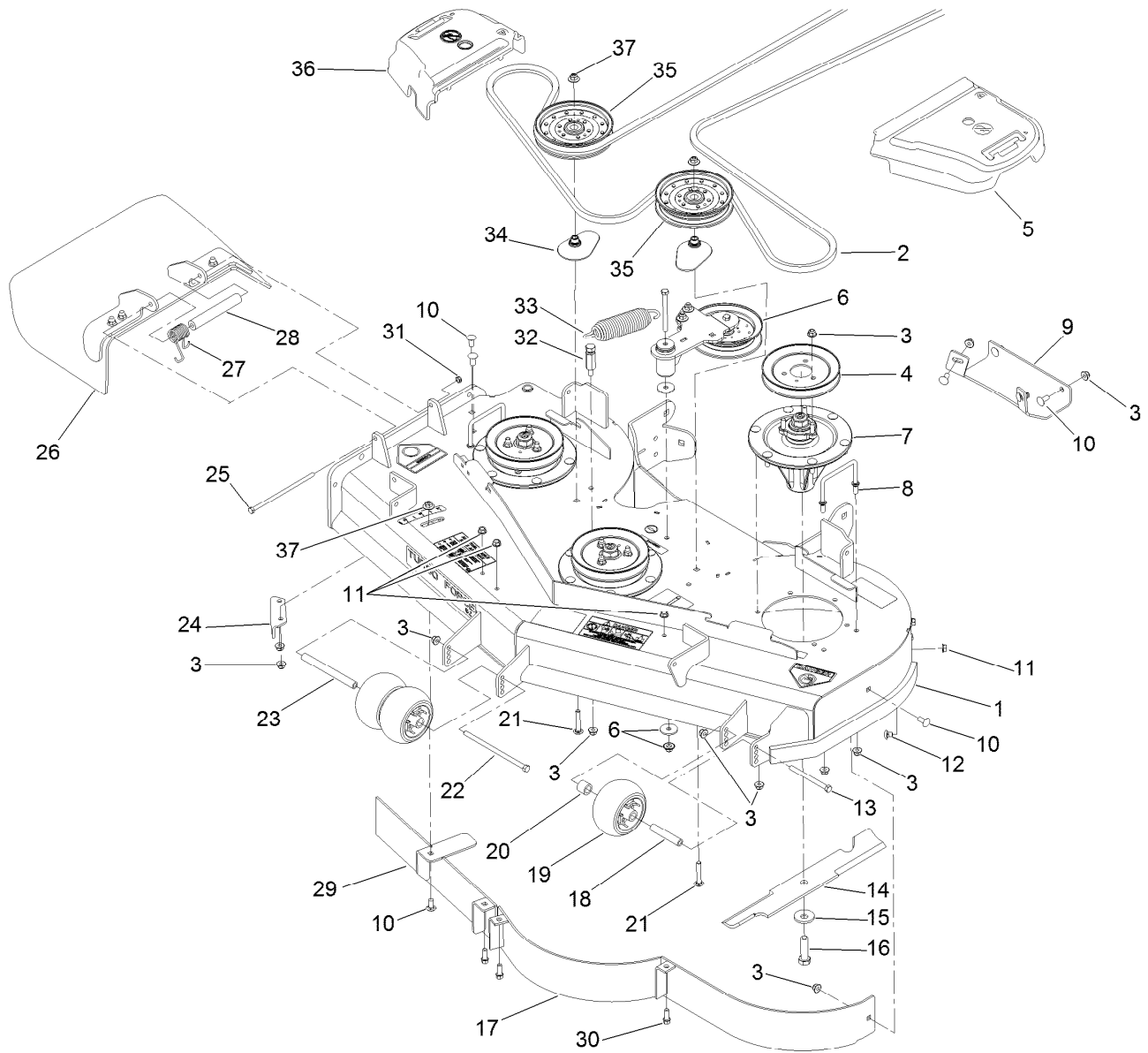

## Deck Assembly

Ref.	Part Number	Qty.	Description	Ref.	Part Number	Qty.	Description
1	114-5810	1	Deck Decal ASM	20	98-7913	1	Tube-Spacer
2	115-7426	1	Belt-V	21	3231-40	2	Bolt-CARR
3	104-8301	41	Nut-Flange, NI	22	108-5388	1	Screw-HH
4	115-7450	3	Pulley	23	98-5967	1	Spacer-Wheel
5	109-6936	1	Cover-Belt, LH	24	107-8541-01	1	Baffle-Discharge
6		1	Idler Arm ASM ●	25	322-50	1	Screw-HH
7	119-8560	3	Spindle ASM	26	108-2792	1	Rubber Deflector ASM
8	109-6982	2	Wireform-Cover	27	108-4052	1	Spring-Torsion
9	112-4230-01	1	Plate-Skid	28	105-4622	1	Spacer
10	3231-27	8	Screw-CARR	29	115-7455-01	1	Baffle ASM
11	3290-357	6	Nut-HHF, Whiz	30	92-1624	3	Screw-HWH
12	108-5387	3	Screw-CARR	31	3296-47	1	Nut-Lock, NI
13	323-23	1	Screw-HH	32	114-5867	1	Anchor-Spring, Tall
14	105-7781-03	3	Blade-18 Inch (Hi Flow)	33	116-0133	1	Extension-Spring
15	103-0865	3	Washer-Blade Bolt, Heavy	34	109-2872	2	Spacer-Pulley
16	51-4060	3	Screw-Blade	35	116-4670	2	Idler-Pulley, Flat
17	115-7461-01	1	Baffle ASM	36	109-6935	1	Cover-Belt, RH
18	98-7912	1	Tube-Spacer	37	109-6658	3	Nut-Flange, NI
19	1-603299	3	Roller-Scalp, Anti				

● Not serviced separately

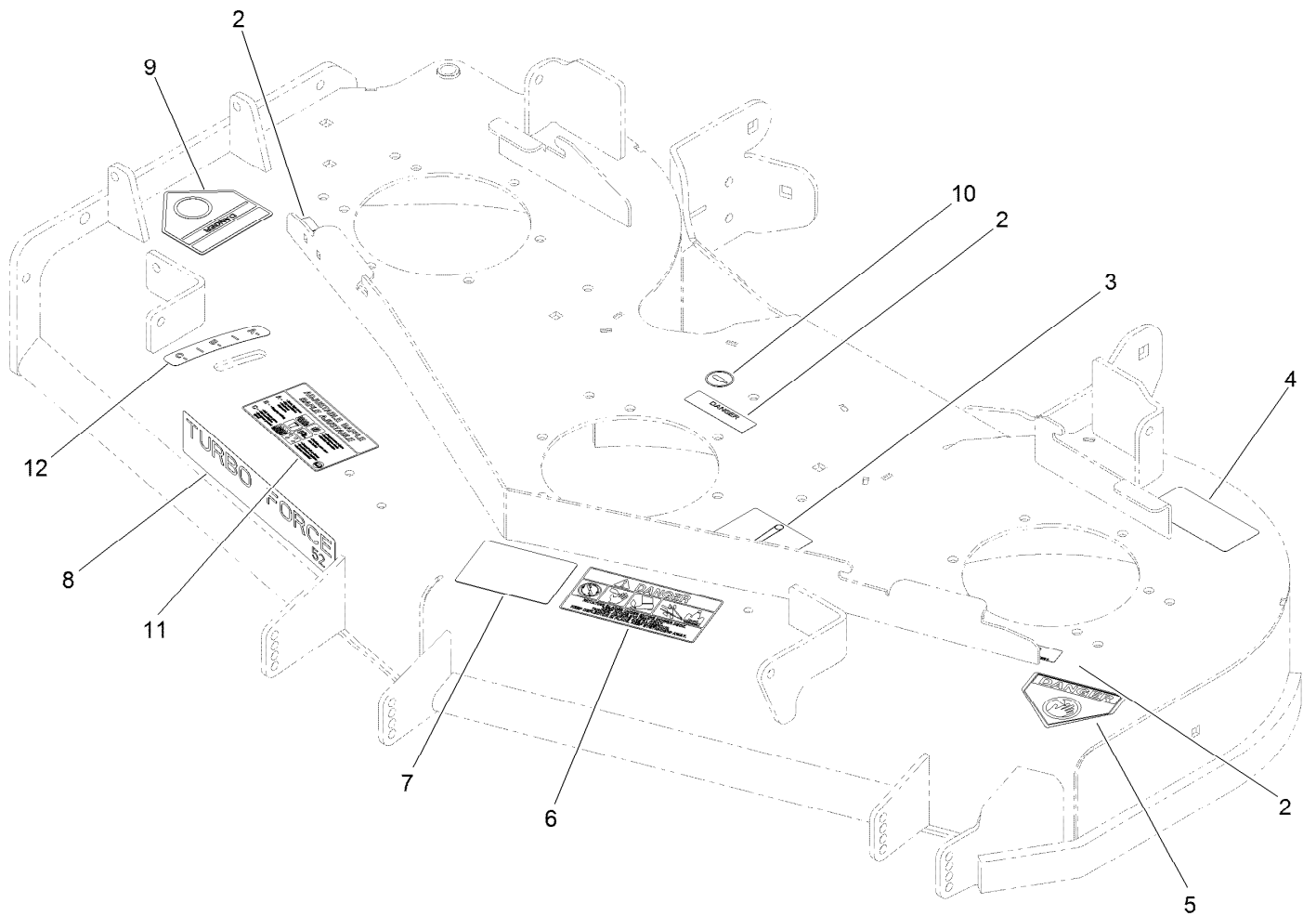

## Deck Decal Assembly No. 114-5810

Ref.	Part Number	Qty.	Description
2	98-5954	3	Decal-Cover, Missing
3	115-7445	1	Decal-Routing, Deck Belt
4	68-8340	1	Decal-Torque
5	1-403005	1	Decal-Danger
6	66-1340	1	Decal-Danger, Thrown Object
7	105-7798	1	Decal-Scalp, Anti
8	107-1618	1	Decal
9	54-9220	1	Decal-Danger
10	58-6520	1	Decal-Grease
11	110-2068	1	Decal-Adjustment, Baffle
12	110-2067	1	Decal-Setting, Baffle

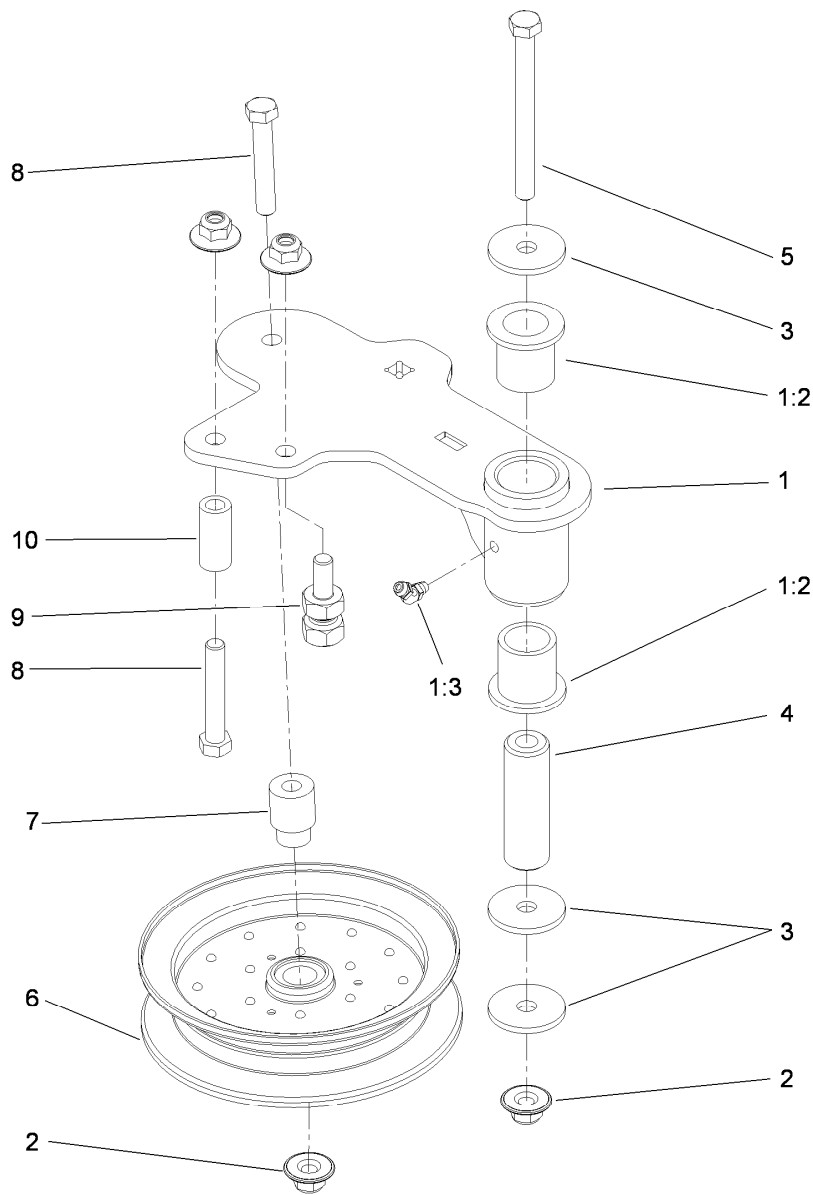

## Idler Assembly

<i>Ref.</i>	<i>Part Number</i>	<i>Qty.</i>	<i>Description</i>
1	114-5870	1	Idler Arm ASM
1:2	1-303514	2	Bearing-Flanged
1:3	1481	1	Fitting-Grease
2	109-6658	4	Nut-Flange, NI
3	1-213069	3	Washer
4	114-5848	1	Spacer-Plain
5	98-5961	1	Screw-HH
6	116-4668	1	Idler-Pulley, Flanged
7	112-4212	1	Mount-Pulley
8	323-11	2	Screw-HH
9	114-5866	1	Anchor-Spring, Short
10	104-0151	1	Spacer

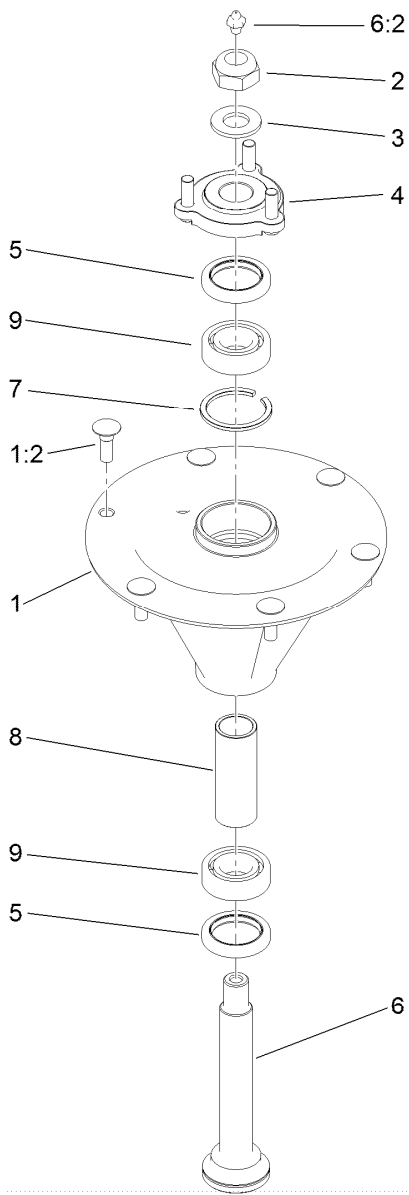

## Spindle Assembly No. 119-8560

<i>Ref.</i>	<i>Part Number</i>	<i>Qty.</i>	<i>Description</i>
1		1	Spindle Housing And Studs ASM ●
1:2	114-8195	6	Bolt-Ribbed Neck
2	3296-67	1	Nut-Lock, NI
3	92-5836	1	Washer
4	117-6172	1	Spindle Hub ASM
5	253-133	2	Seal-Oil
6	119-8527	1	Spindle Shaft And Zerk ASM
6:2	302-2	1	Fitting-Grease
7	119-8532	1	Snap Ring
8	117-6184	1	Spacer
9	119-8558	2	Bearing-Noseal

● Not serviced separately

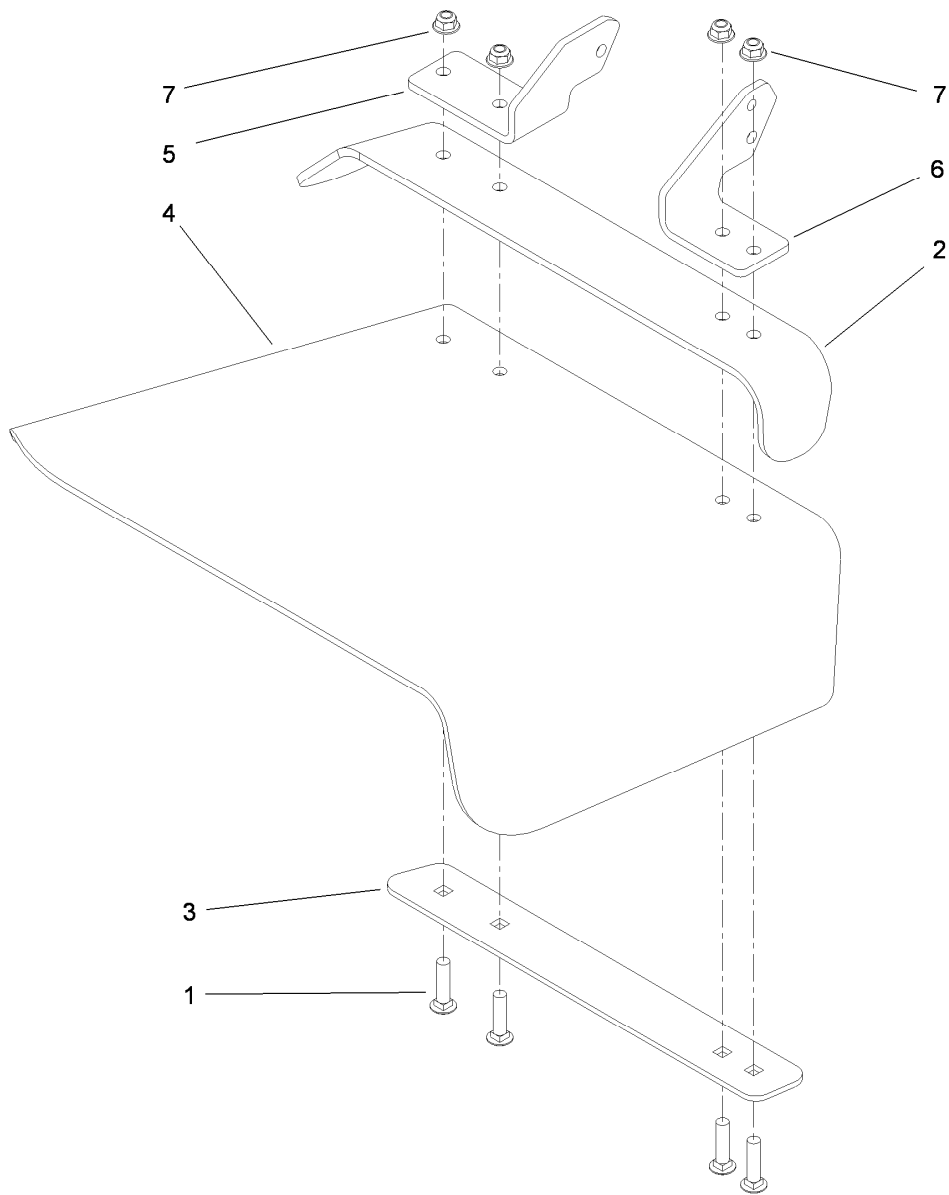

## Rubber Deflector Assembly No. 108-2792

<i>Ref.</i>	<i>Part Number</i>	<i>Qty.</i>	<i>Description</i>
1	3231-4	4	Screw-CARR
2	106-3246-01	1	Deflector
3	106-3248-03	1	Strap-Discharge
4	108-5029	1	Deflector-Rubber
5	108-4059-01	1	Plate-Hinge, Rear
6	106-3253-01	1	Plate-Hinge, Front
7	104-8301	4	Nut-Flange, NI

# Attachments and Accessories

## For 74953 Z Master Riding Mower with 52in TURBO FORCE Side Discharge Mower

<b>Product Name</b>	<b>Model/Part</b>
Blade-Recycler, 18in.....	105-7779-03
Blade-Hi Flow, 18in.....	105-7781-03
Blade-Med Flow, 18in.....	105-7794-03
Blade-Low Flow, 18in.....	105-7795-03
Blade-Atomic, 18in.....	105-7796-03
Blade-Hi Flow, 18in (6 Pack).....	108-1117
Blade-Atomic, 18in (6 Pack).....	108-1118
Hitch Kit.....	109-9487
Blade-Lo Flow, 18in (6 Pack).....	110-0406
Blade-Recycler, 18in (6 Pack).....	110-0408
Blade-Med Flow, 18in (6 Pack).....	110-0409
Hypr-Oil 500 (quart).....	114-4713
Hypr-Oil 500 (gallon).....	114-4714
Hypr-Oil 500-5 (5 gallon).....	114-4715
Bimini Folding Shade Assembly.....	115-4510
Recycler Kit.....	115-7467
Roller Striper Kit.....	115-7470
Light Kit.....	116-1154
Z Stand Kit.....	117-0350
Operator-Controlled Discharge Chute Kit.....	117-3600
Deluxe Suspension Seat Kit.....	117-6174
Toro Deluxe Rider Cover.....	490-7319
Spark Arrestor Screen.....	75-6880
Blower and Drive Kit.....	78552
E-Z Vac Twin Bagging System.....	78562
E-Z Vac DFS Collection System.....	78566
Filter Minder Gauge.....	99-4664
Trash Holder Kit.....	TC26

**Notes:**

**Notes:**



**Count on it.**