

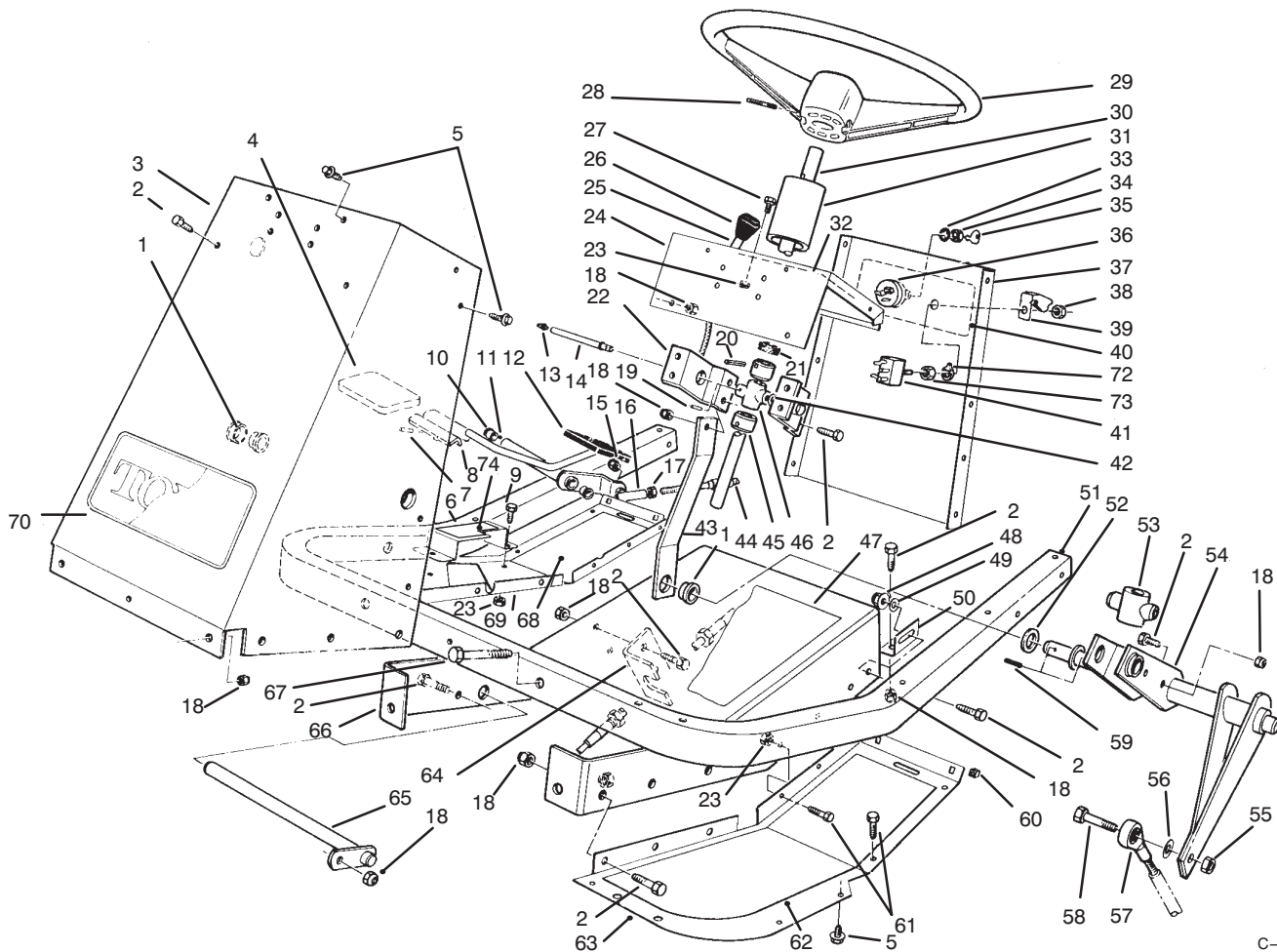

MODEL NO. 30611-690001 Thru 790001 and UP	PARTS CATALOG
PROLINE 120	



C-1626

FRAME & STEERING ASSEMBLY

Ref. No.	Part No.	Description	No. Used
1	27-9080	Bushing	3
2	322-4	Screw - Hex. Hd.	19
3	54-1900	Tower - Front	1
4	49-6470	Pad - Accelerator	1
5	46-8560	Screw - Hex. Hd.	25
6	80-4930	Footrest - Pedal	1
7	32121-51	Pin - Roll	1
8	80-4920	Pedal - Accelerator	1
9	321-3	Screw - Hex. Hd.	2
10	256-156	Bushing	2
11	74-0110	Pedal - Traction (Incl. Ref. #10)	1
12	49-6430	Pad - Reverse	1
13	302-22	Fitting - Grease	1
14	59-1610	Tube - Grease Fitting	1

Ref. No.	Part No.	Description	No. Used
15	3296-3	Nut - Hex.	1
16	2411-34	Ball Joint	1
17	3220-1	Nut - Jam	1
18	3296-29	Nut - Lock	24
19	32121-20	Pin - Roll	1
20	32121-31	Pin - Roll	2
21	21-9260	Cover - Dust	1
22	54-1950	Bracket - Support Bearing	2
23	3296-42	Nut - Lock	16
24	54-1000	Tower - Top	1
25	54-1451	Control - Throttle, Choke	2
26	66-0120	Knob	2
27	321-2	Screw - Hex. Hd.	4
28	32121-10	Pin - Roll	1

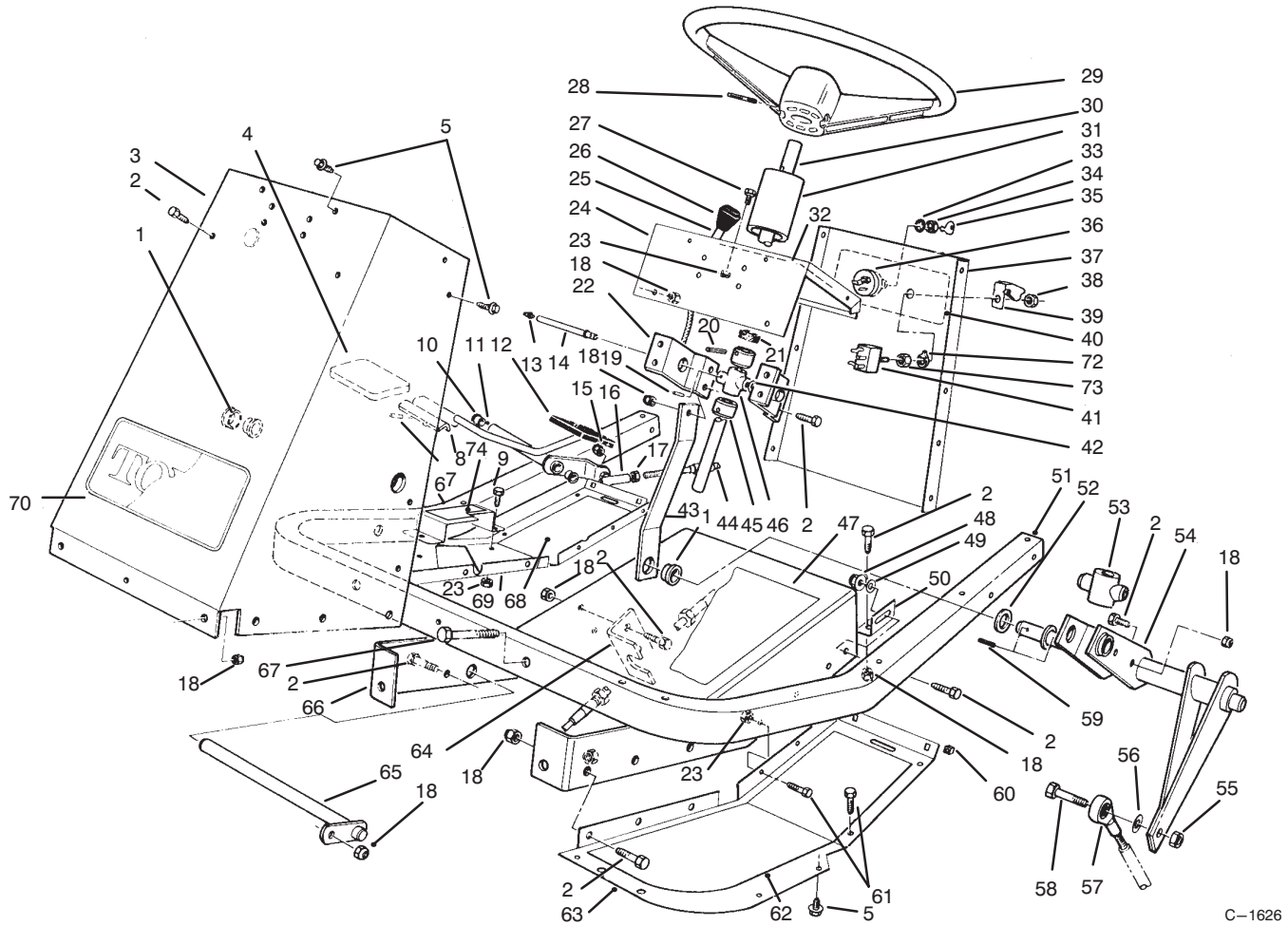

C-1626

FRAME & STEERING ASSEMBLY

Ref. No.	Part No.	Description	No. Used
29	88-3850	Wheel - Steering	1
30	54-1420	Shaft - Steering	1
31	47-1980	Cover Steering Shaft	1
32	93-7281	Decal - Throttle Choke	1
33	3254-5	Washer - Lock	1
34	218-461	Nut - Lock	1
35	63-8360	Key	2
36	88-9830	Switch - Ignition (Incl. Ref. #33-35)	1
37	92-6266	Panel - Tower Rear	1
38	113179	Nut	1
39	113050	Cover - P.T.O. Switch	1
40	93-7284	Decal - Switch	1
41	116716	Switch - Clutch & Brake (Incl. Ref. # 38, 72 & 73)	1
42	3290-440	Washer - Belleville	1
43	54-1340	Link - Steering	1
44	54-2640	Cable - Traction Control	1
45	28-3940	Collar - Steering Shaft	2
46	60-9050	Bearing - Steering Shaft	1
47	93-7306	Decal - Tunnel	1
48	32128-20	Nut - Flange Lock	2
49	3256-23	Washer - Flat	4
50	54-1440	Bracket - Tunnel	2

Ref. No.	Part No.	Description	No. Used
51	60-9140	Frame - Footrest	1
52	3-6498	Washer - Thrust	2
53	54-2630	Follower - Steering Shaft	1
54	54-2040	Follower Lever	1
55	3296-48	Nut - Lock	1
56	3256-4	Washer - Flat	1
57	251-304	Rod End	1
58	324-7	Screw - Hex. Hd.	1
59	32121-77	Pin Roll	2
60	32115-5	Nut - Square	4
61	321-4	Screw - Hex. Hd.	14
62	54-2260	Pad Footrest L.H.	1
63	54-1470	Footrest - L.H.	1
64	54-1770	Bracket - Cable Traction	1
65	59-1550	Pedal - Shaft	1
66	60-9150	Tunnel	1
67	322-10	Screw - Hex. Hd.	2
68	54-2270	Pad - Footrest R.H.	1
69	80-4910	Footrest - R.H.	1
70	62-7400	Decal - Toro	1
72	102950	Washer	1
73	105805	Nut	1
74	82-4720	Pad - Footrest	1

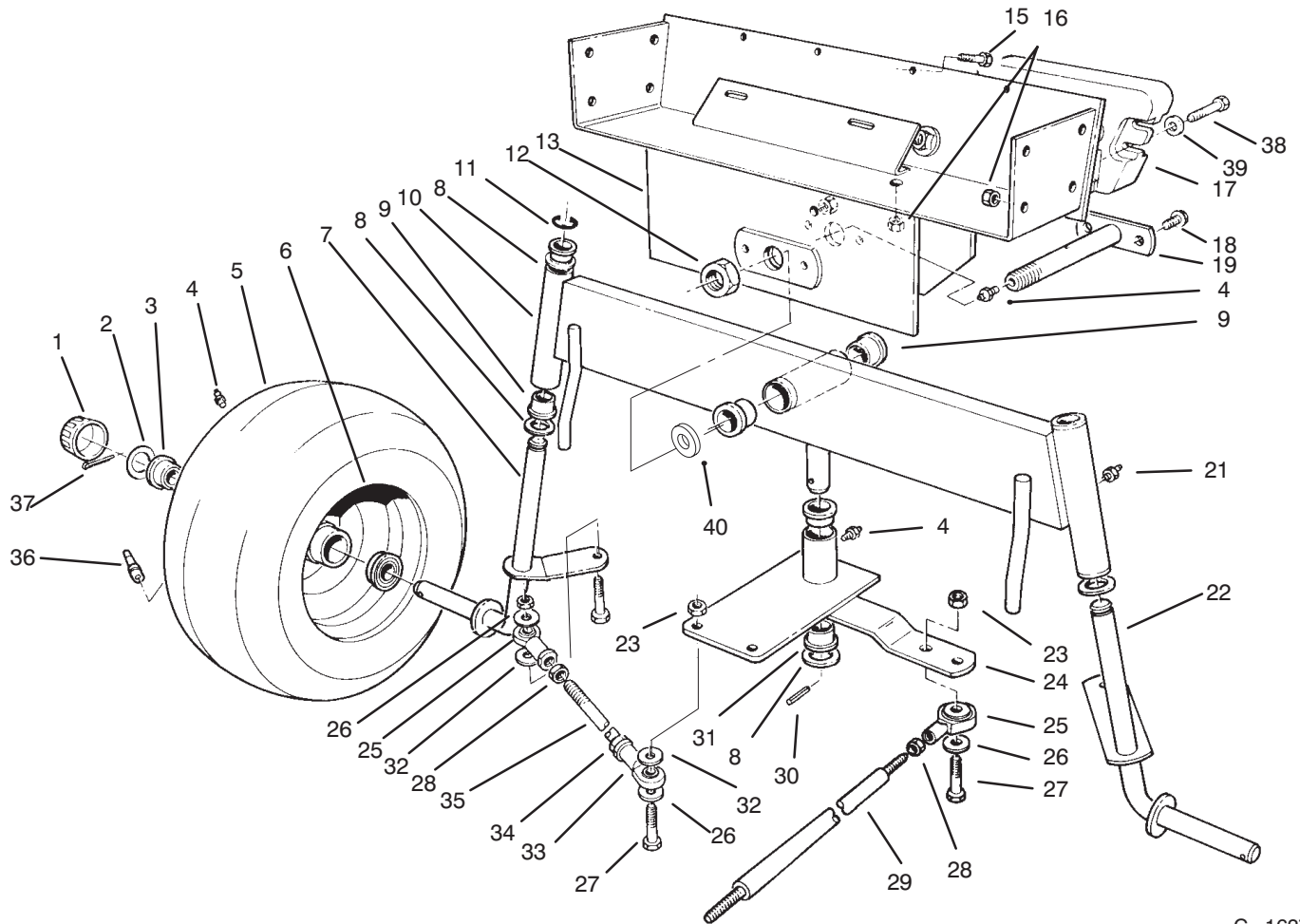

C-1627

REAR AXLE ASSEMBLY

Ref. No.	Part No.	Description	No. Used	Ref. No.	Part No.	Description	No. Used
1	61-9780	Hub Cap	2	22	54-0560	Spindle L. H.	1
2	28-2480	Washer - Flat	2	23	3296-48	Nut	5
3	251-210	Bearing - Ball	4	24	92-6257	Plate- Pivot (Incl. Ref. #4 & 30)	1
4	302-5	Fitting - Grease	4	25	251-305	Rod End	3
5	231-126	Tire	2	26	3256-4	Washer - Flat	7
6	242-60	Rim	2	27	324-7	Screw	5
7	54-0570	Spindle R.H.	1	28	3220-4	Nut - Jam	3
8	3-6498	Washer - Thrust	5	29	54-1491	Rod - Steering , Rear	1
9	46-6680	Bushing	6	30	32121-51	Pin - Roll	1
10	92-6255	Axle - Rear (Incl. Ref. #9 & 20)	1	31	27-9080	Bushing	2
11	32151-48	Ring - Retaining	2	32	62-4420	Spacer	9
12	3296-41	Nut - Hex.	1	33	251-304	Rod End	2
13	54-0330	Frame - Rear	1	34	3220-19	Nut - Jam	2
15	321-4	Screw	4	35	57-3100	Tie Rod - Steering	2
16	3296-29	Nut	8	36	232-27	Valve Stem w/Cap	2
17	24-5790	Weight - Rear	1	37	3272-12	Pin - Cotter	2
18	32144-15	Screw	2	38	325-6	Screw	2
19	59-1500	Pivot - Axle	1	39	3253-7	Washer	2
21	302-49	Fitting - Grease	3	40	3256-39	Washer	1

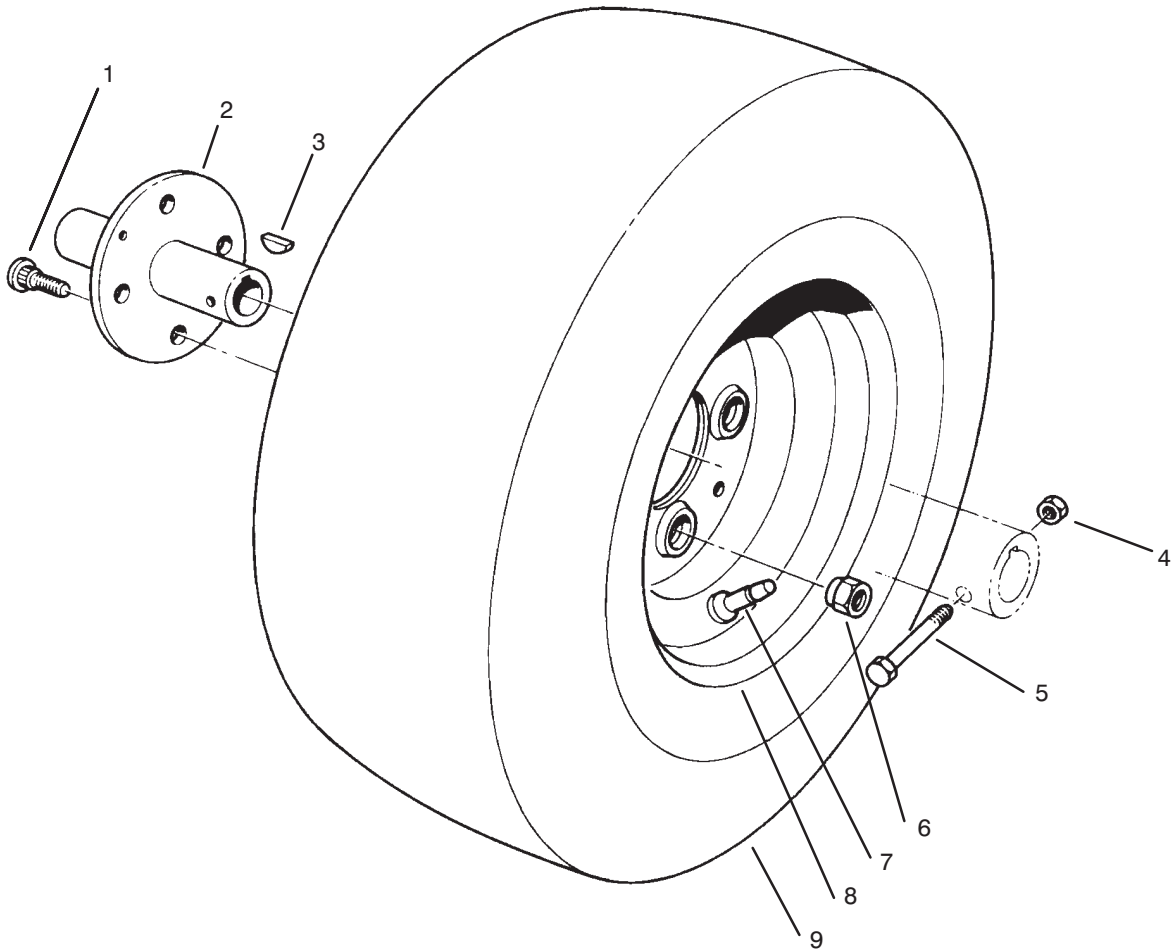

T-0071

FRONT WHEEL ASSEMBLY

Ref. No.	Part No.	Description	No. Used
1	242-71	Bolt - Wheel	8
2	54-0140	Hub - Wheel	2
3	3257-10	Key - Woodruff	2
4	3296-29	Nut - Lock	2
5	322-10	Screw	2

Ref. No.	Part No.	Description	No. Used
6	242-50	Nut	8
7	232-27	Valve Stem w/Cap	2
8	242-76	Rim	2
9	231-122	Tire	2

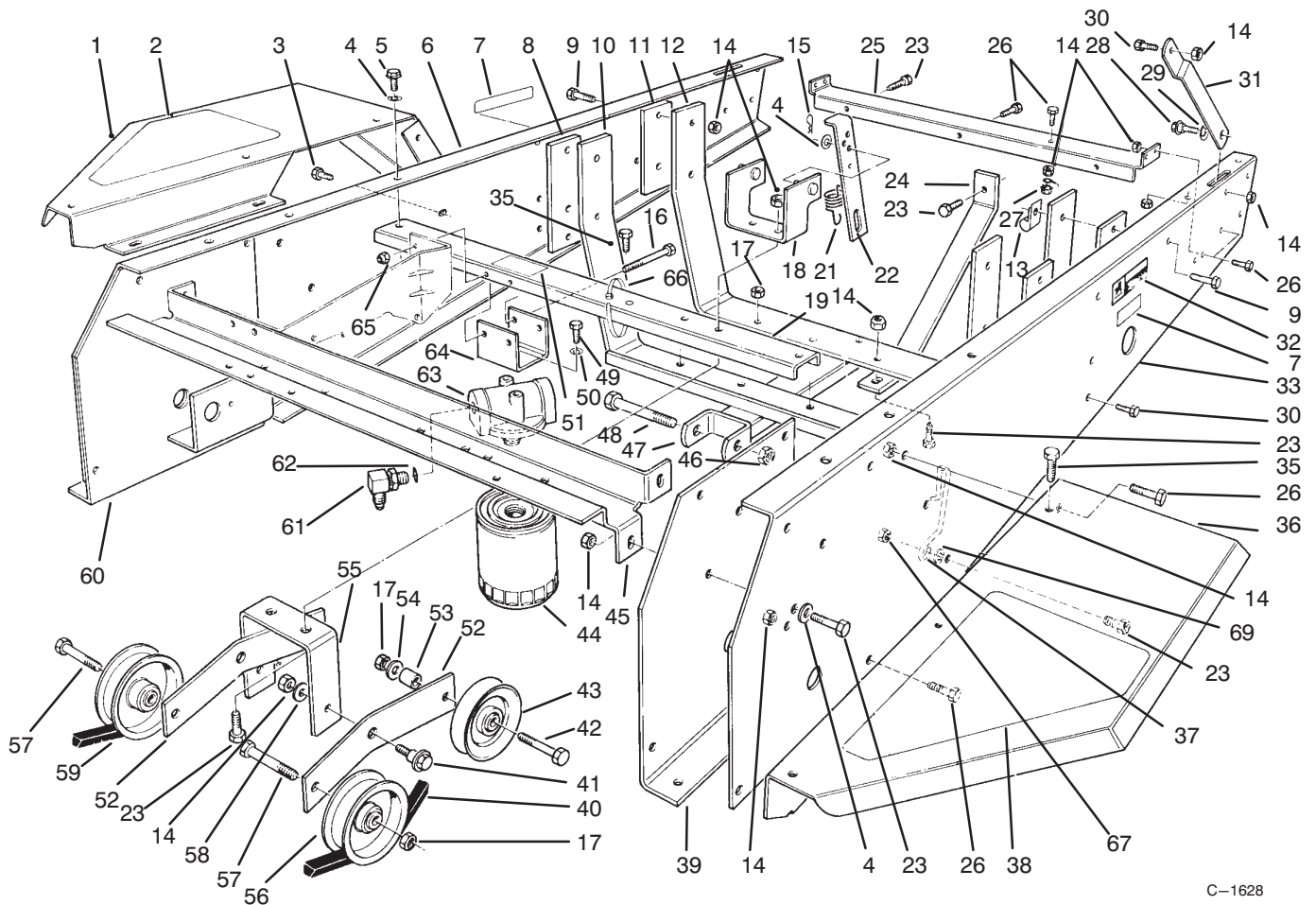

C-1628

FRAME & JACKSHAFT ASSEMBLY

Ref. No.	Part No.	Description	No. Used
1	54-1930	Fender R.H.	1
2	92-6292	Pad - Fender R.H.	1
3	3234-14	Screw	4
4	3256-23	Washer - Flat	8
5	32144-11	Screw - Thread Forming	2
6	54-1910	Channel - Side R.H.	1
7	93-7272	Decal - Caution	2
8	54-1800	Plate - Engine Front	2
9	322-6	Screw	8
10	92-6250	Mount - Engine	1
11	54-1810	Plate - Engine, Rear	2
12	92-6251	Mount - Engine	1
13	2412-100	"J" Clamp	2
14	3296-29	Nut	33
15	3290-250	Pin - Cotter	2
16	321-14	Screw	2
17	3296-44	Nut	4
18	54-2070	Anchor - Spring	1
19	54-2500	Channel - Middle	1
20	323-7	Screw	3
21	54-1410	Spring - Idler	2
22	54-1130	Link - Idler Anchor	2

Ref. No.	Part No.	Description	No. Used
23	322-6	Screw	11
24	92-6254	Bar - Tension	1
25	54-1830	Support - Shield	1
26	322-4	Screw	13
27	32149-1	Nut - Lock	1
28	27-0410	Bolt - Shoulder	2
29	3290-211	Washer - Spring	2
30	322-2	Screw	4
31	54-1870	Stop - Hood, Lower	2
32	93-8071	Decal - Hot Surface	1
33	54-1920	Channel - Side L.H.	1
35	46-8560	Screw	7
36	54-1940	Fender L.H.	1
37	55-4860	Guide - Belt	1
38	92-6293	Pad - Fender L.H.	1
39	54-0460	Axle Stand - L.H.	1
40	54-1380	JackShaft - "V" Belt	1
41	19-1470	Bolt - Shoulder	2
42	323-11	Screw	2
43	62-4530	Idler - "V" Belt	2
44	54-0110	Filter - Transmission Oil	1
45	54-1010	Channel - Front	1

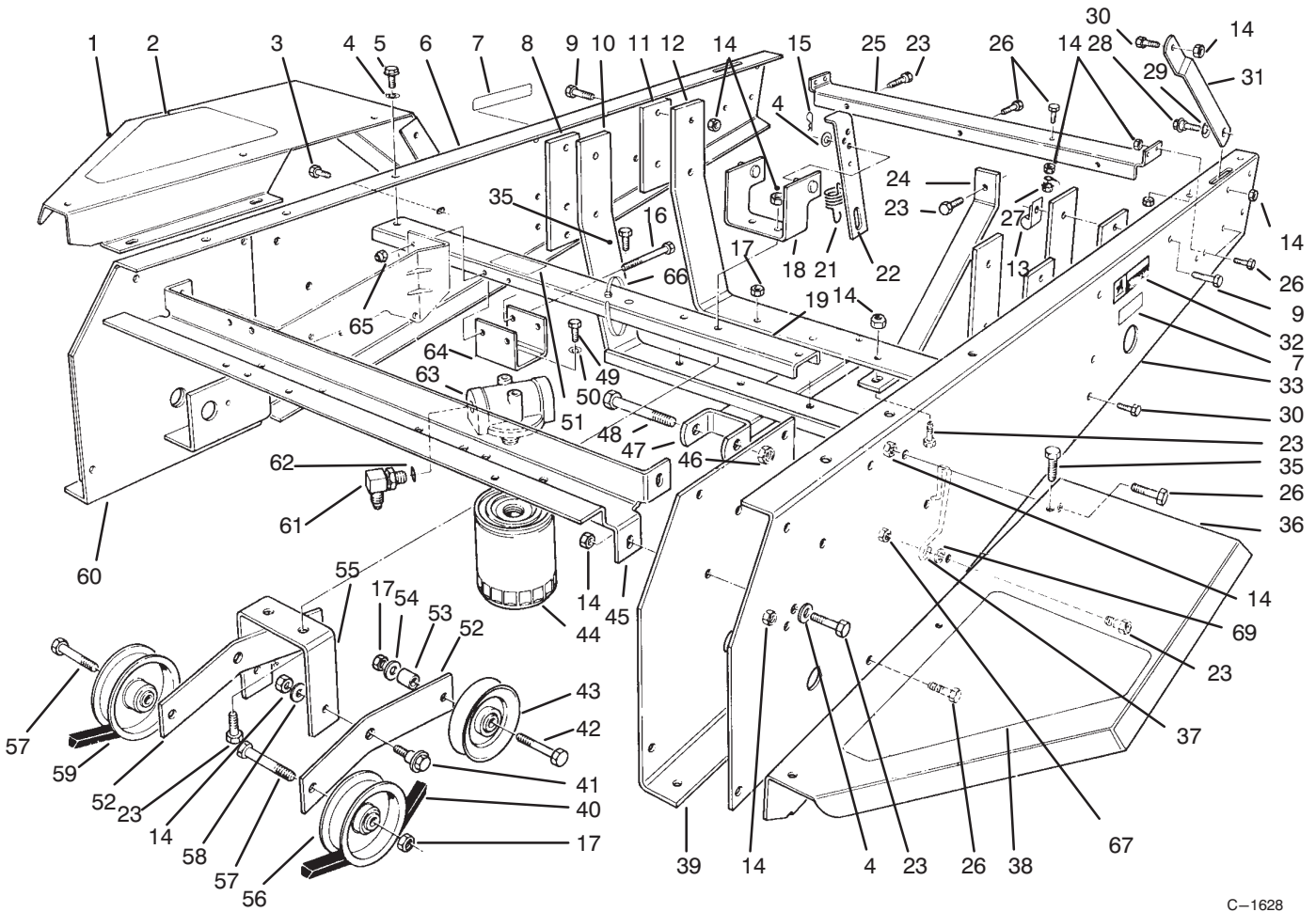

C-1628

FRAME & JACKSHAFT ASSEMBLY (Continued)

Ref. No.	Part No.	Description	No. Used
46	3296-61	Nut	1
47	92-6252	Mount - Cylinder	1
48	327-24	Screw	1
49	321-3	Screw	2
50	3253-3	Washer - Lock	2
51	93-7823	Decal - Oil	1
52	54-9200	Lever - Idler	2
53	37-7250	Spacer	2
54	3256-3	Washer - Flat	2
55	54-1060	Bracket - Idler Mount	1
56	62-4540	Idler - Flat	2
57	323-9	Screw	2

Ref. No.	Part No.	Description	No. Used
58	23-1120	Washer - Flat	2
59	54-1390	"V" Belt - Traction	1
60	54-0450	Axle Stand R.H.	1
61	353-371	Fitting - 90°	2
62	237-79	"O" Ring	1
63	54-0100	Filter Head Assembly	1
64	54-1120	Bracket - Filter Head	1
65	3296-42	Nut - Lock	2
66	3290-379	Cable Tie	7
67	32128-20	Nut - Flange Lock	1
69	3255-8	Washer - Lock, Ext. Tooth	1

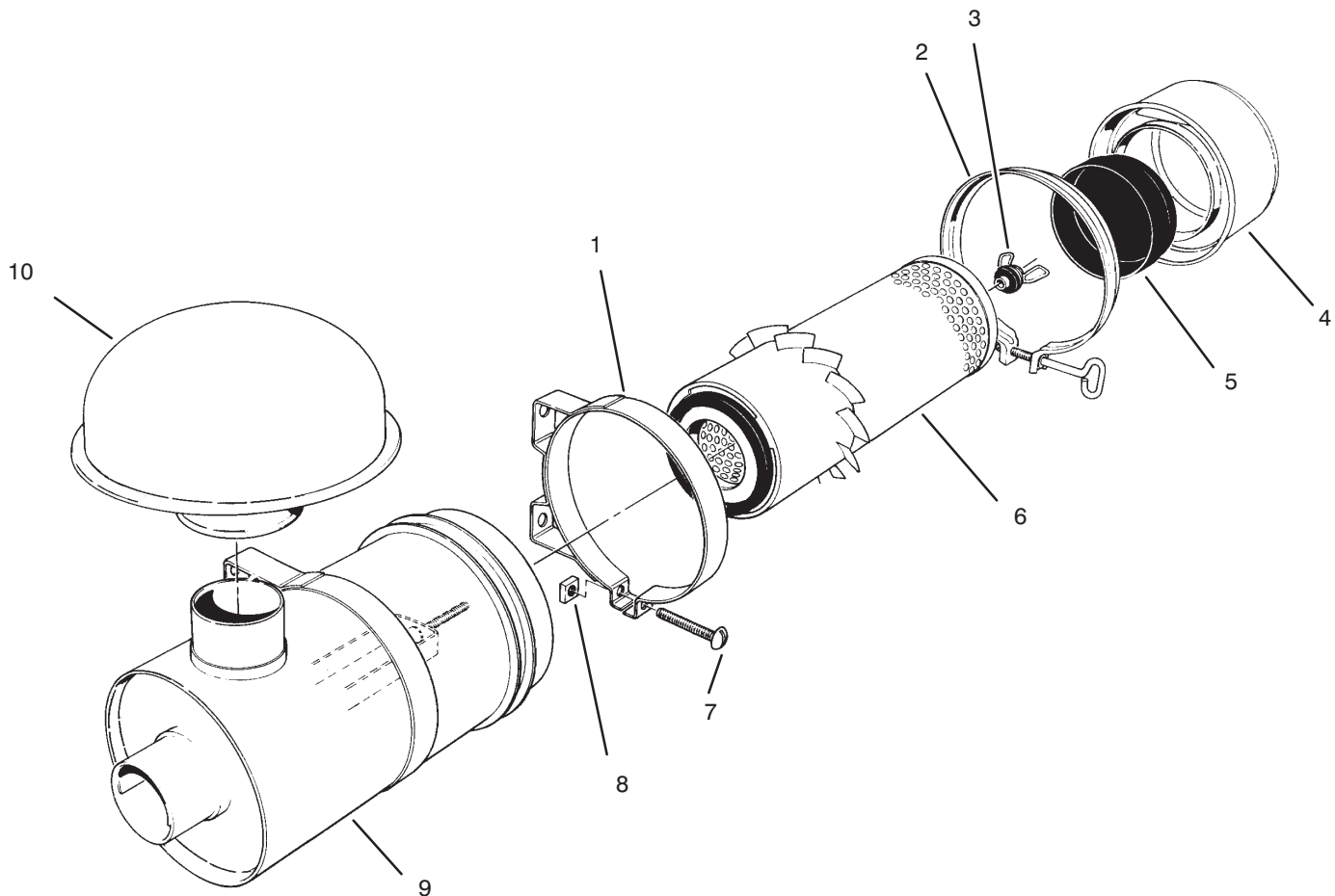

T-0248

AIR CLEANER, MODEL NO. 11-4659

Ref. No.	Part No.	Description	No. Used
1	33-1350	Band Assembly (Incl. Ref. #7 & 8)	2
2	33-1340	Clamp Assembly	1
3	33-1330	Nut Assembly	1
4	33-1320	Cup	1
5	33-1310	Baffle	1

Ref. No.	Part No.	Description	No. Used
6	33-1300	Element Assembly	1
7	3258-19	Screw - Round Hd.	2
8	32107-11	Nut - Square	2
9		Body Assembly	1
10	46-7510	Hood - Intake	1

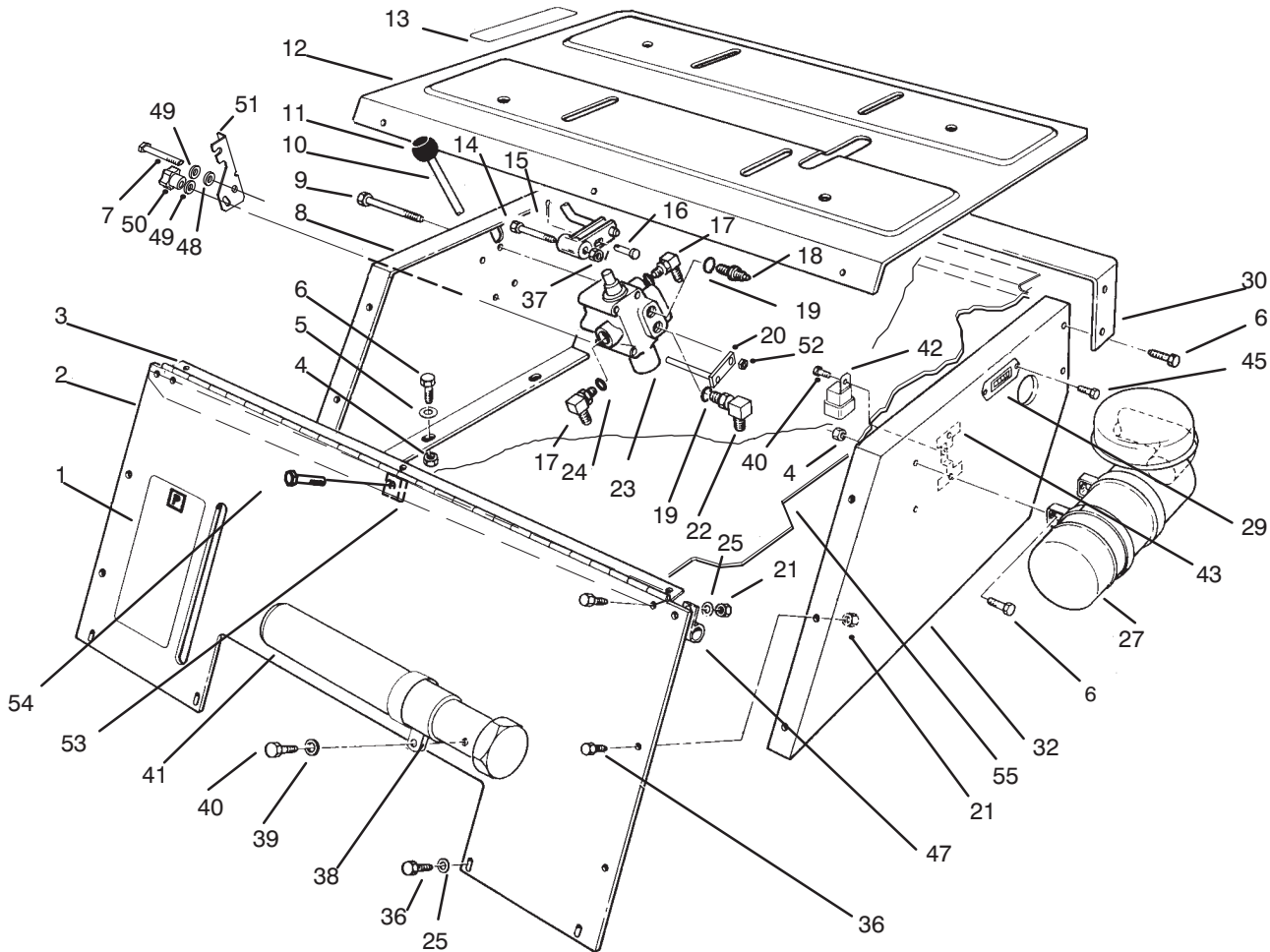

SEAT SUPPORT ASSEMBLY

Ref. No.	Part No.	Description	No. Used
1	93-7296	Decal - Parking Brake	2
2	80-3760	Support - Seat, Front	1
3	54-1310	Hinge - Seat	1
4	3296-29	Nut	12
5	3256-23	Washer - Flat	6
6	322-4	Screw	12
7	321-23	Screw - Hex. Hd.	1
8	54-1220	Support - Seat R.H.	1
9	321-23	Screw	2
10	82-4680	Lever - Valve	1
11	233-37	Knob	1
12	92-6281	Plate - Seat	1
13	93-7300	Decal - Lift Control	1
14	56-6590	Screw	1
15	3272-6	Pin - Cotter	1
16	283-17	Pin - Clevis	1
17	353-511	Fitting	2
18	353-545	Fitting	1
19	237-78	"O"Ring	2
20	94-1283	Control Block	1
21	3296-42	Nut - Lock	18
22	353-375	Fitting - 90°	1
23	54-0090	Valve Assembly	1
24	237-42	"O"Ring	2

Ref. No.	Part No.	Description	No. Used
25	3256-1	Washer - Flat	10
27	11-4659	Air Cleaner Assembly	1
29	75-6820	Meter - Hour	1
30	54-1550	Support - Hood	1
32	92-5435	Support - Seat L.H.	1
36	321-4	Screw	5
37	3296-39	Nut	1
38	2412-120	"R"Clamp	2
39	3256-51	Washer	2
40	32104-76	Screw	4
41	74-0720	Tube - Manual	1
42	63-7590	Relay	1
43	92-6259	Bracket	1
45	32144-18	Screw	2
47	2412-93	Clamp - Wire	1
48	93-9476	Spacer - Latch	1
49	3256-22	Washer - Flat	2
50	233-67	Knob	1
51	93-9475	Bracket - Hydraulic Lock	1
52	3296-56	Nut - Lock	1
53	3290-199	Nut - Speed	1
54	321-5	Screw - Hex. Hd.	1
55	93-9477	Cover - Belt	1

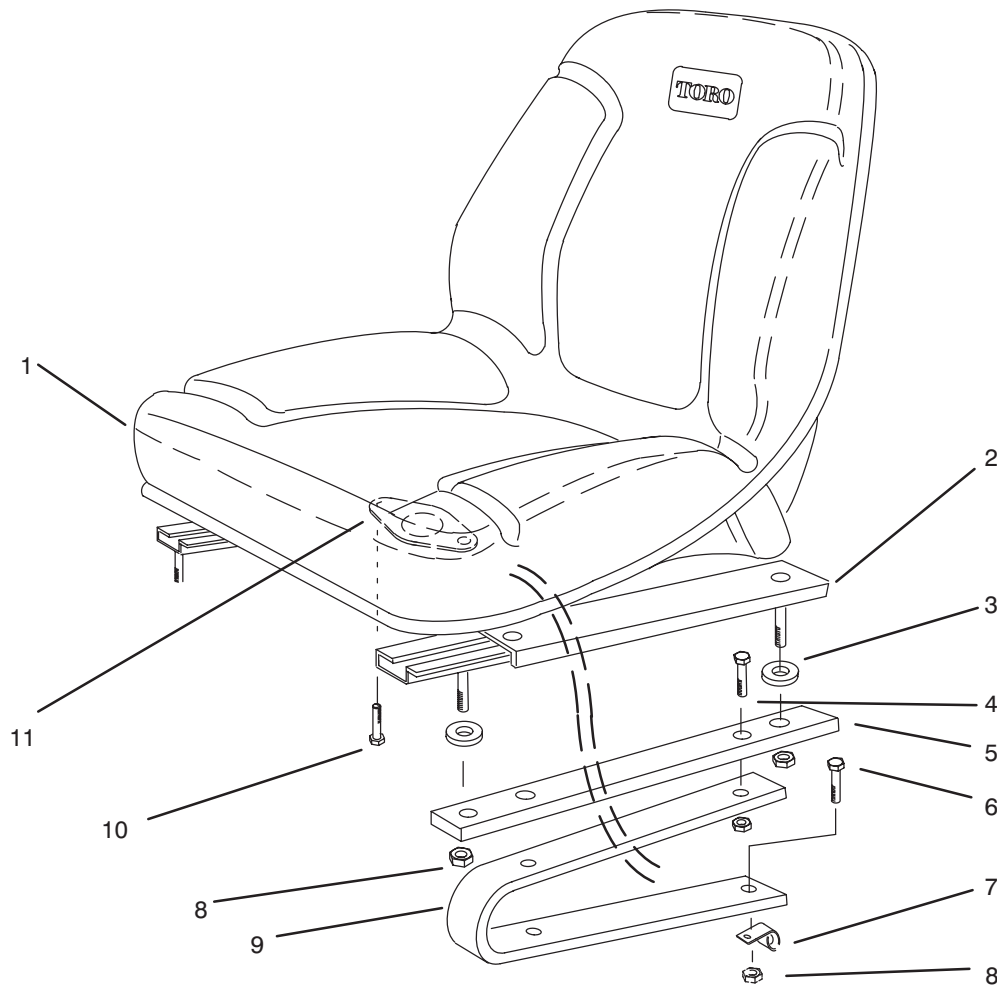

C-1603

SEAT ASSEMBLY

Ref. No.	Part No.	Description	No. Used
1	92-6280	Seat	1
2	51-0790	Slide Seat Adjust Assembly	1
*	51-0780	Slide Seat Assembly R.H.	1
3	109989	Spacer	4
4	322-4	Screw	4
5	92-6284	Plate - Adapter, Seat	2

Ref. No.	Part No.	Description	No. Used
6	322-5	Screw	4
7	2412-93	Clamp - Hose	1
8	3296-29	Nut - Lock	8
9	114263	Spring - Seat	2
10	321-4	Screw	2
11	92-6282	Switch - Seat	1

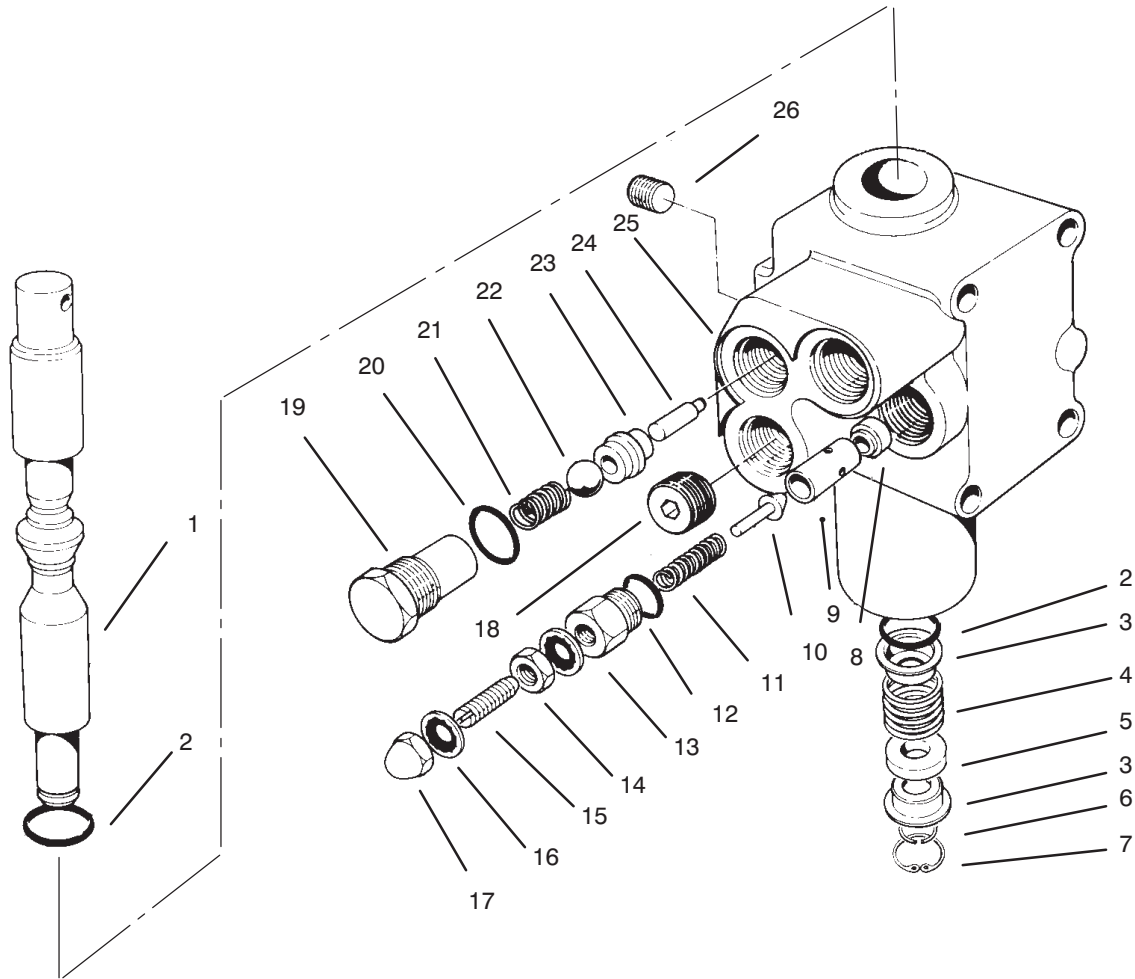

T-0075

VALVE ASSEMBLY NO. 54-0090

Ref. No.	Part No.	Description	No. Used
1	54-0260	Spool	1
2	22-8500	"O"Ring	2
3	22-8380	Retainer - Spring	2
4	22-8410	Spring	1
5	27-5200	Spacer	1
6	22-8480	Ring - Retaining	1
7	22-8490	Ring -Retaining	1
8	55-3640	Seat - Relief	1
9		Guide	1
10		Plunger	1
11		Spring	1
12		"O"Ring	1
13		Cap - PV Adjustment	1
14		Nut	1

Ref. No.	Part No.	Description	No. Used
15		Screw - Set	1
16		Stat O Seal	1
17		Nut - Acorn	1
18	28-1120	Plug	1
19	22-8330	Plug	1
20	237-42	"O"Ring	2
21	22-8340	Spring	1
22	22-8350	Ball	1
23	22-8370	Seat - Check Valve	1
24	22-8360	Pin - Cam	1
25		Body	1
26	55-3650	Plug	1
*	55-3630	Adjustable Relief Valve (Incl. Ref. #9-17)	1

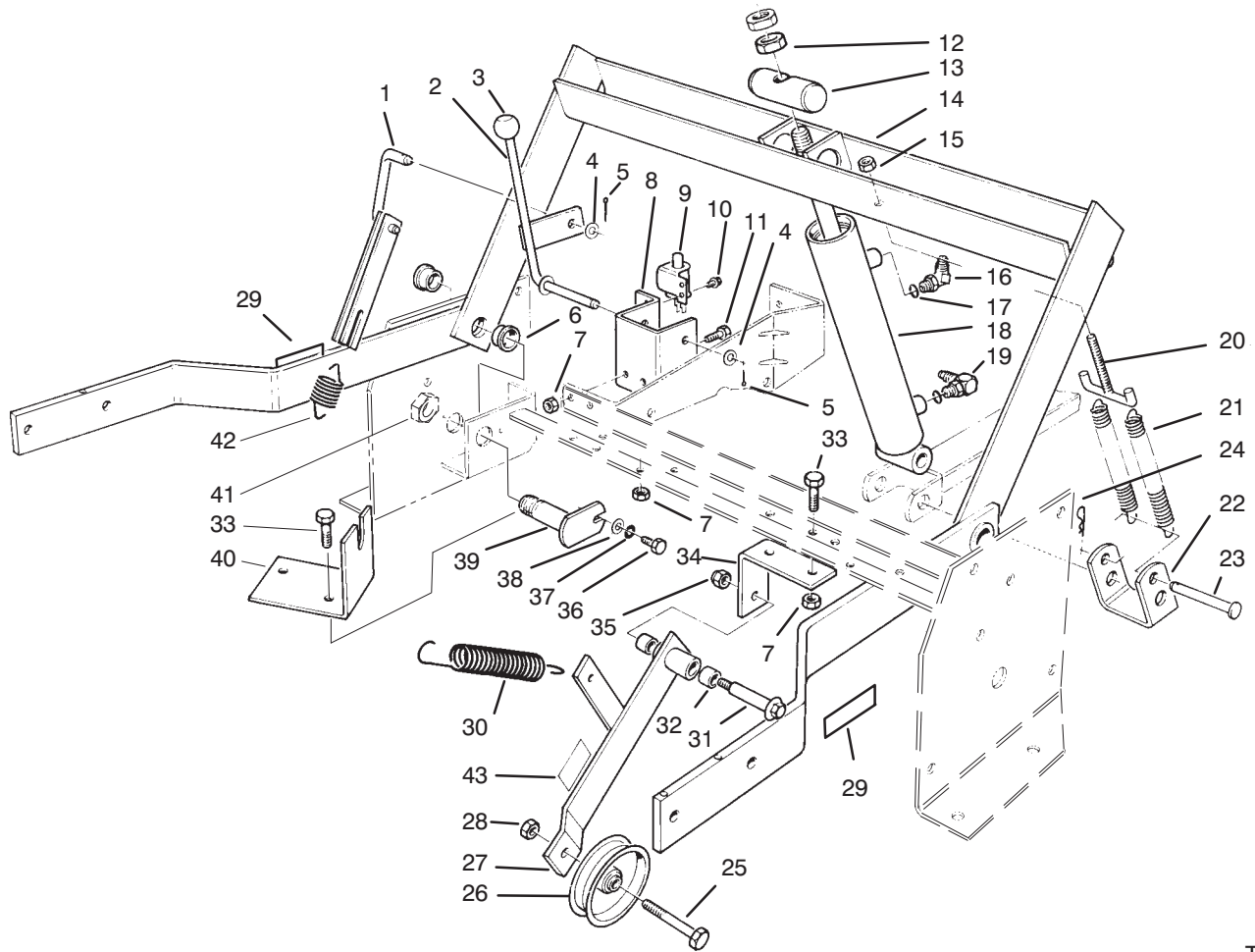

T-0076

PARKING BRAKE & LIFT FRAME ASSEMBLY

Ref. No.	Part No.	Description	No. Used	Ref. No.	Part No.	Description	No. Used
1	54-2120	Link - Parking Brake	1	23	283-55	Pin - Clevis	1
2	54-2110	Lever - Brake	1	24	3290-355	Pin - Cotter	1
3	233-37	Knob	1	25	323-10	Screw	1
4	3256-24	Washer - Flat	2	26	36-3220	Pulley - Idler	1
5	3272-10	Pin - Cotter	2	27	12-1109	Lever - Idler	1
6	27-9080	Bushing	4			(Incl. Ref. #43)	1
7	3296-29	Nut	6	28	3296-44	Nut	1
8	54-1270	Bracket - Parking Brake	1	29	93-7331	Decal - Warning	2
9	55-7120	Switch - Brake	1	30	54-1170	Spring - Extension	1
10	32144-1	Screw - Thread Forming	2	31	27-6230	Bolt - Shoulder	1
11	322-6	Screw	2	32	256-154	Bushing	2
12	3220-6	Nut - Jam	2	33	322-4	Screw	4
13	54-2000	Pin - Pivot	1	34	55-7310	Bracket - Idler	1
14	66-1570	Frame - Lift (Incl. Ref. #6)	1	35	3296-6	Nut	1
15	32153-3	Nut	2	36	321-2	Screw	2
16	353-431	Fitting - 45°	1	37	3253-3	Washer	2
17	237-78	"O"Ring	2	38	3256-1	Washer	2
18	54-0150	Cylinder - Lift	1	39	54-2100	Pin - Pivot	2
19	353-375	Fitting - 90°	1	40	56-6920	Bracket - Cable Extension	1
20	56-3320	"T"Hook	1	41	3296-15	Nut	2
21	56-2760	Spring - Extension	2	42	54-0960	Spring - Parking Brake	1
22	56-3370	Bracket - Spring	2	43	93-6696	Decal - Spring Load	1

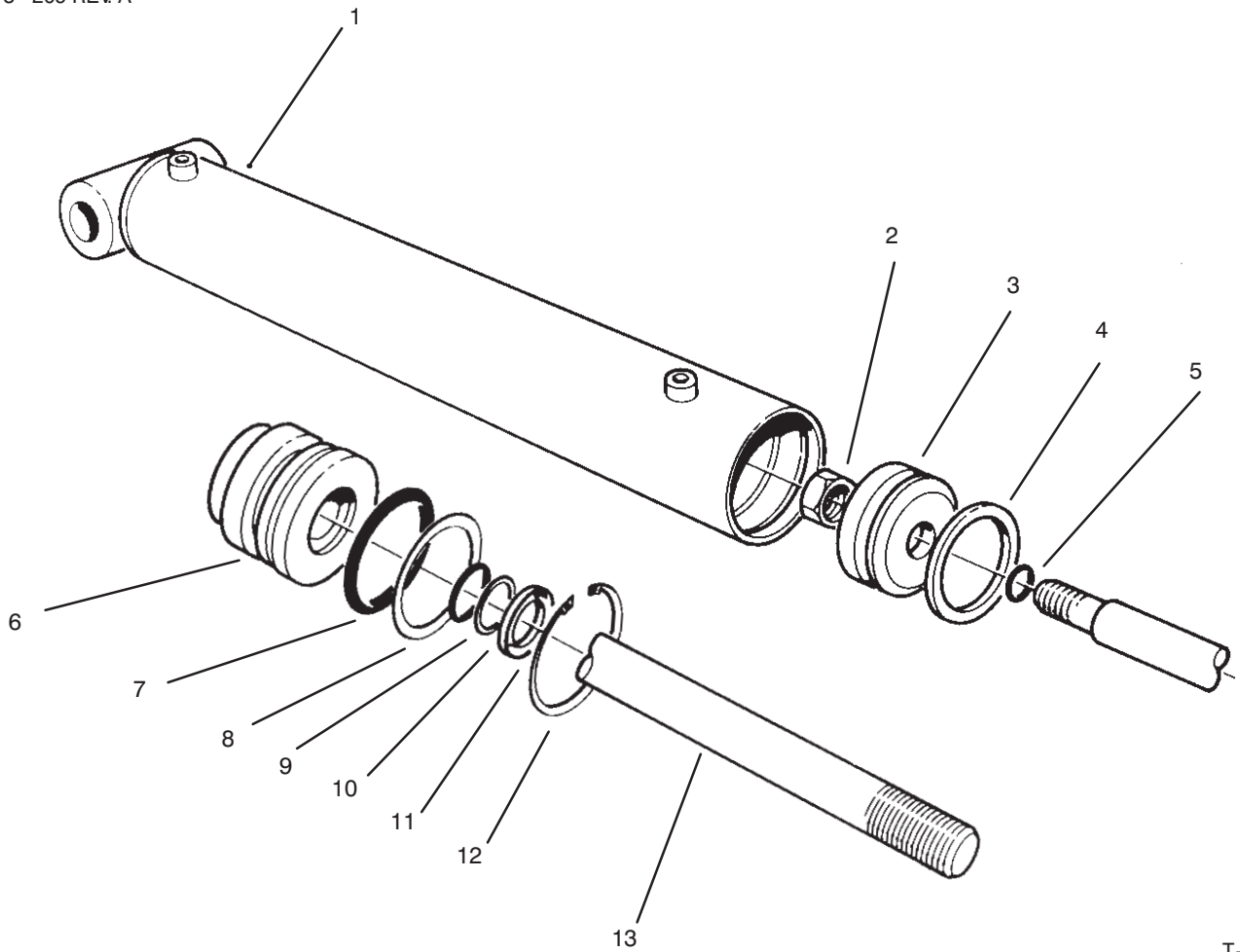

T-0077

HYDRAULIC LIFT CYLINDER NO. 54-0150

Ref. No.	Part No.	Description	No. Used
1†		Barrel	1
2	32152-10	Nut - Lock	1
3	54-0300	Piston	1
4		Uniring	1
5		"O"Ring	1
6	54-0310	Head	1
7		"O"Ring	1
8		Washer - Backup	1

Ref. No.	Part No.	Description	No. Used
9		"O"Ring	1
10		Washer - Backup	1
11		Seal - Dust	1
12	43-5220	Ring - Retaining	1
13	54-0280	Shaft	1
*	54-0290	Seal Repair Kit (Incl. Ref. #4, 5 & 7-11)	1

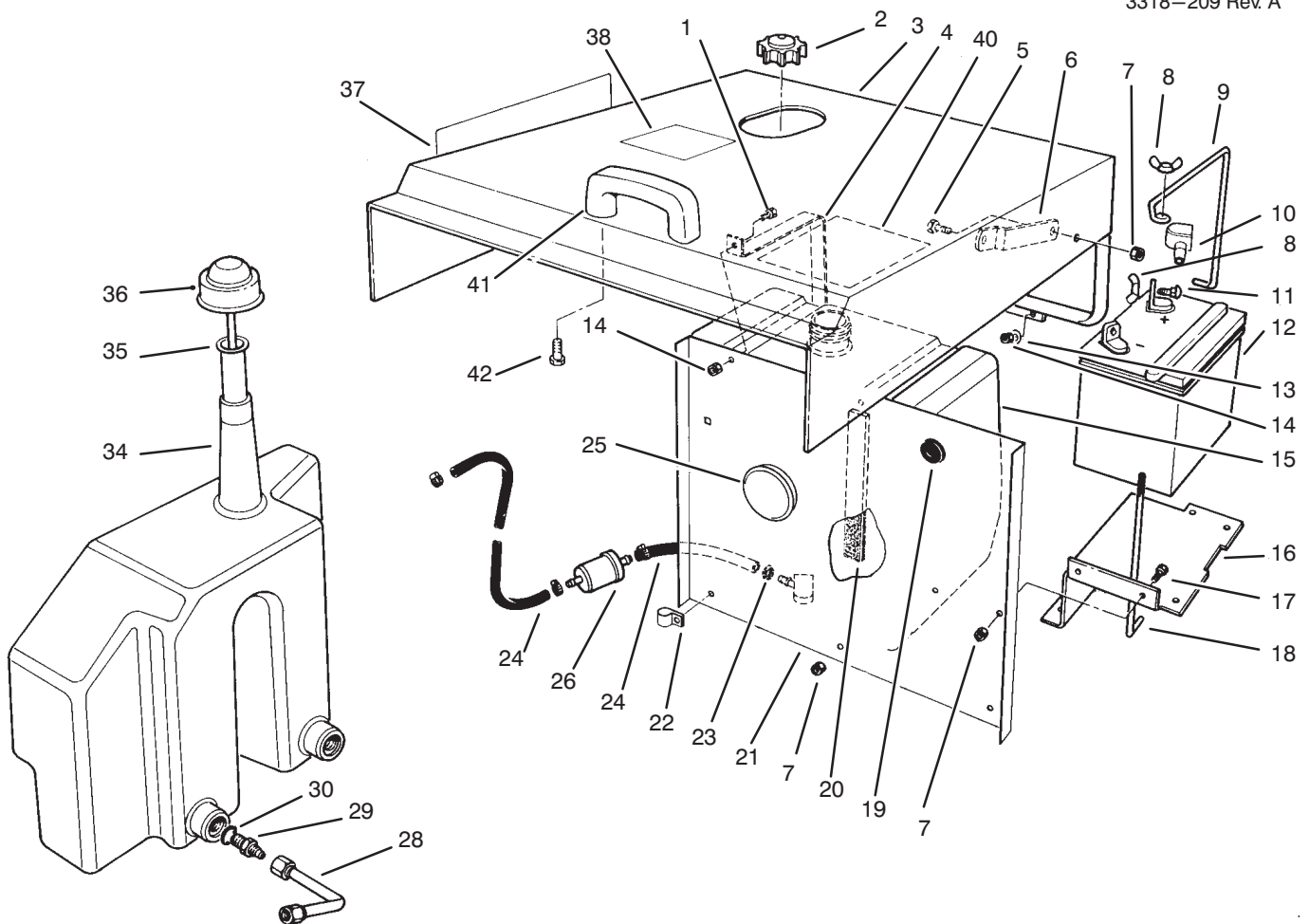

C-1630

HOOD, FUEL TANK & HYDRAULIC RESERVOIR ASSEMBLY

Ref. No.	Part No.	Description	No. Used	Ref. No.	Part No.	Description	No. Used
1	321-3	Screw - Hex. Hd.	2	21	92-6267	Shield - Heat	1
2	55-3570	Cap - Fuel	1	22	2412-100	"R"Clamp	1
3	14-4109	Hood	1	23	2412-108	Clamp - Hose	4
4	54-1880	Strap - Fuel Tank	2	24	92-6283	Hose - Fuel	2
5	322-3	Screw - Hex. Hd.	2	25	92-6274	Plug - Cap	1
6	54-1860	Stop - Hood Upper	2	26	38-8000	Filter - Fuel	1
7	3296-29	Nut - Hex.	9	28	54-2310	Hydraulic Tube Assembly Transmission to Reservoir	1
8	32103-22	Nut - Wing	3	29	353-385	Fitting - Hydraulic Straight (Incl. Ref. #30)	2
9	54-1260	Clamp - Battery	1	30	237-42	"O"Ring	2
10	77-0981	Boot - Terminal	1	34	54-2470	Reservoir - Hydraulic	1
11	3229-1	Bolt - Carriage	4	35	29-0590	Screen	1
12	82-4640	Battery	1	36	36-4950	Cap - Oil	1
13	3256-1	Washer	4	37	92-6276	Decal - Proline 120	2
14	3296-42	Nut - Lock	8	38	93-7822	Decal - Refueling	1
15	62-4040	Tank - Fuel	1	40	92-6288	Decal - Service	1
16	54-1850	Support - Battery	1	41	65-5100	Handle	1
17	322-4	Screw - Hex. Hd.	2	42	46-8091	Screw	2
18	12-5950	Rod - Battery Support	1				
19	237-100	Grommet	1				
20	54-1890	Foam - Tank	2				

*Not Illustrated

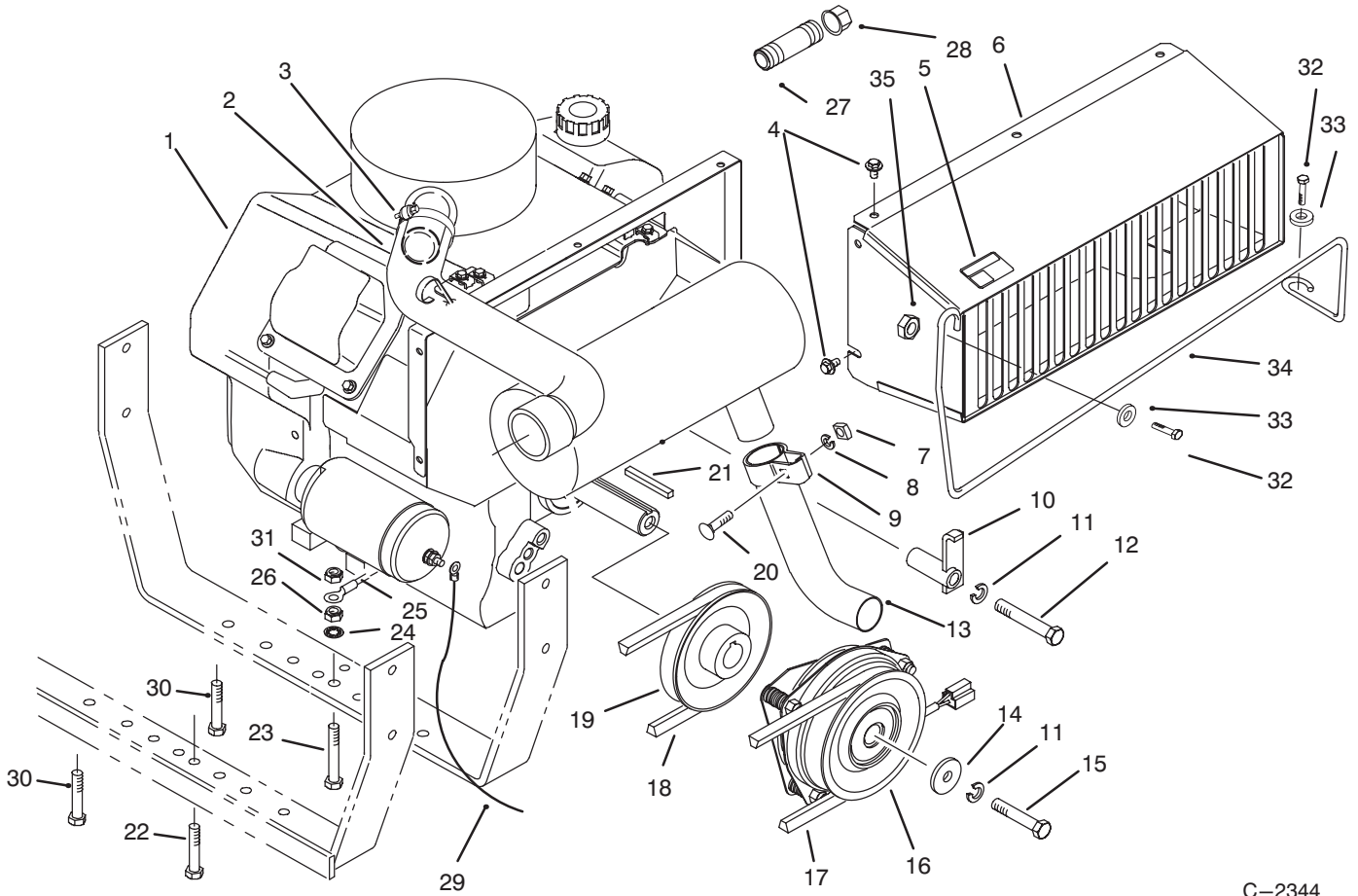

C-2344

ENGINE ASSEMBLY

Ref. No.	Part No.	Description	No. Used
1		Engine – Kohler 20 HP Model CH20QS PS 64556	1
2	94-1296	Hose – Carburetor	1
3	2412-92	Clamp – Hose	2
4	48-7610	Screw	5
5	93-8069	Decal – Hot Surface	1
6	92-6260	Duct – Engine	1
7	3217-6	Nut – Square	1
8	3253-4	Washer – Lock	1
9	55-8660	Assembly – Clamp (Incl. Ref. #7, 8 & 20)	1
10	54-2160	Bracket – Anchor	1
11	3253-6	Washer – Lock	2
12	324-11	Screw – Hex. Hd.	1
13	54-2290	Pipe – Exhaust	1
14	44-8160	Washer – Flat	1
15	3212-24	Screw – Hex. Hd.	1
16	54-0220	Assembly – Clutch	1
17	54-1380	V-Belt	1

Ref. No.	Part No.	Description	No. Used
18	54-1390	V-Belt	1
19	54-2330	Pulley – Engine	1
20	3230-3	Bolt – Carriage	1
21	5-0930	Key	1
22	323-10	Screw – Hex. Hd.	1
23	323-12	Screw – Hex. Hd.	1
24	3254-6	Washer – Lock, Int. Tooth	1
25	92-6287	Wire – Ground	1
26	3296-39	Nut – Lock	2
27	289-46	Nipple – Pipe	1
28	288-10	Cap – Pipe	1
29	28-3894	Wire – Positive	1
30	323-9	Screw	2
31	3290-357	Nut – Wizz	1
32	322-5	Screw	2
33	3256-23	Washer	2
34	93-9478	Guard – Muffler	1
35	3296-29	Nut	2

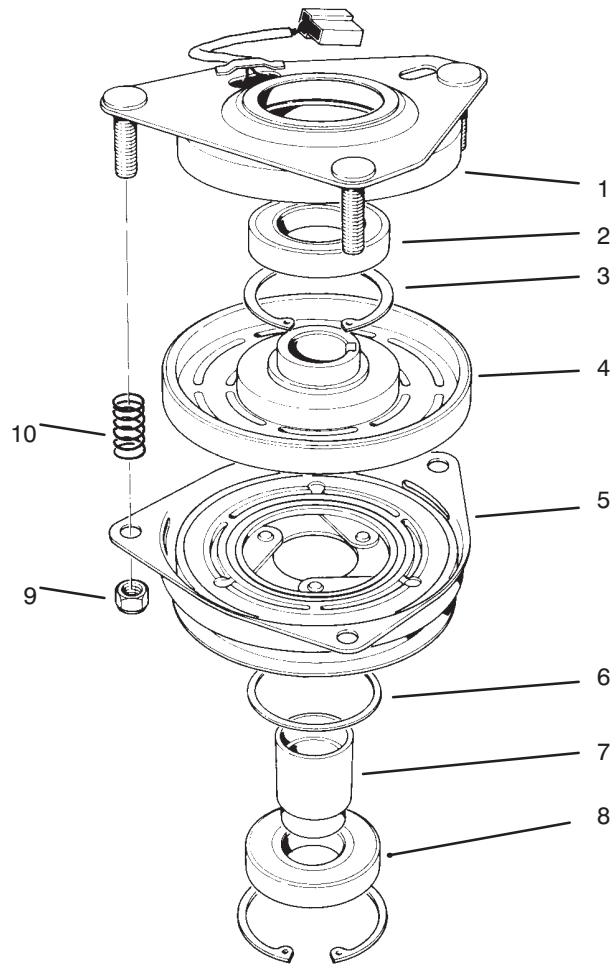

T-0080

CLUTCH ASSEMBLY NO. 54-0220

Ref. No.	Part No.	Description	No. Used	Ref. No.	Part No.	Description	No. Used
1	54-0230	Field Assembly (Incl. Ref. #2 & 3)	1	6	44-8330	Spacer - Bearing	1
2	251-292	Bearing - Field	1	7	44-8340	Collar - Bearing	1
3	44-8310	Ring - Retaining	2	8	251-291	Bearing - Pulley	1
4	44-8360	Field Coil, Rotor & Bearing (Incl. Ref. #1)	1	9	3296-6	Nut - Lock	3
5	44-8370	Armature & Pulley Assembly (Incl. Ref. #3, 6, 7 & 8)	1	10	44-8320	Spring	3

IGNITION SWITCH CIRCUITRY

START	B+S+I	
RUN	A+B+I	X+Y
OFF	OPEN	

PTO SWITCH CIRCUITRY

ON	A + B
OFF	C + D

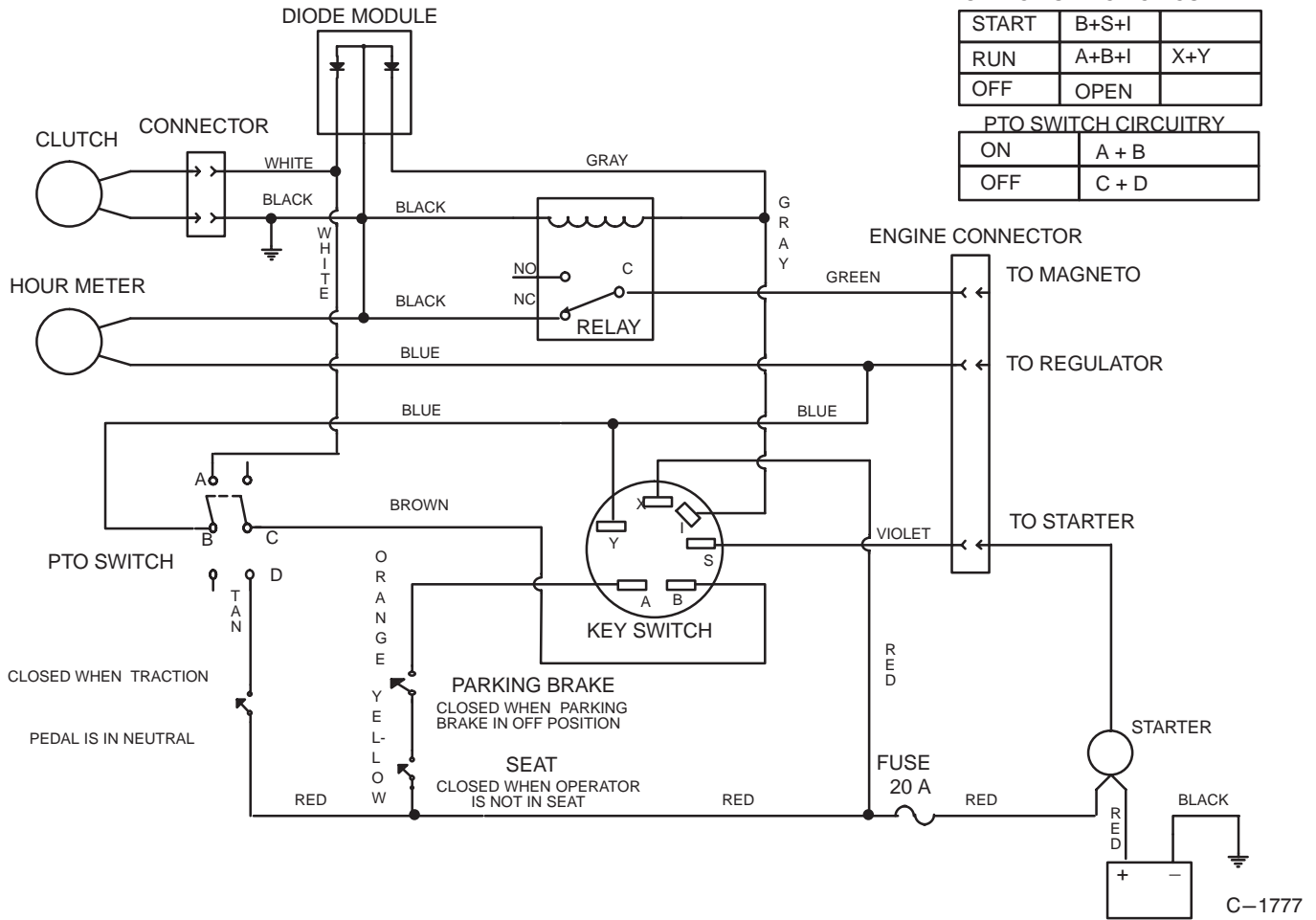

ELECTRIC SCHEMATIC

Ref. No.	Part No.	Description	No. Used
*	94-5848	Harness - Wire	1
*	94-5849	Diode	1

Ref. No.	Part No.	Description	No. Used

*Not Illustrated

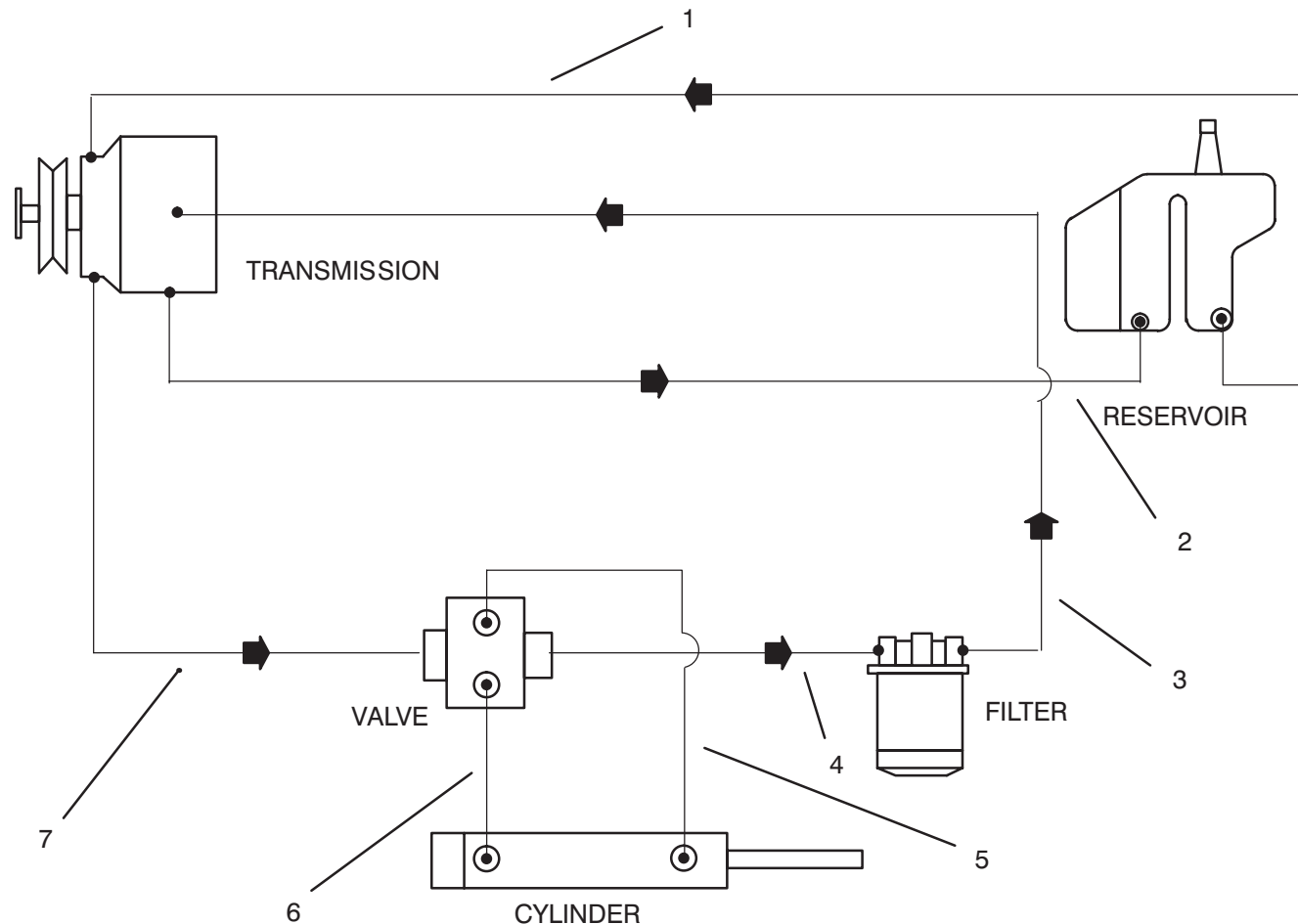

T-0084

HYDRAULIC SCHEMATIC

Ref. No.	Part No.	Description	No. Used
1	56-3390	Hydraulic Hose Assembly Reservoir to Transmission	1
2	54-2310	Hydraulic Tube Assembly	1
3	54-2580	Hydraulic Hose Assembly Filter to Transmission	1
4	54-2570	Hydraulic Hose Assembly Valve to Filter	1

Ref. No.	Part No.	Description	No. Used
5	54-2610	Hydraulic Hose Assembly Cylinder to Valve	1
6	54-2620	Hydraulic Hose Assembly Cylinder to Valve	1
7	54-2590	Hydraulic Hose Assembly Transmission to Valve	1

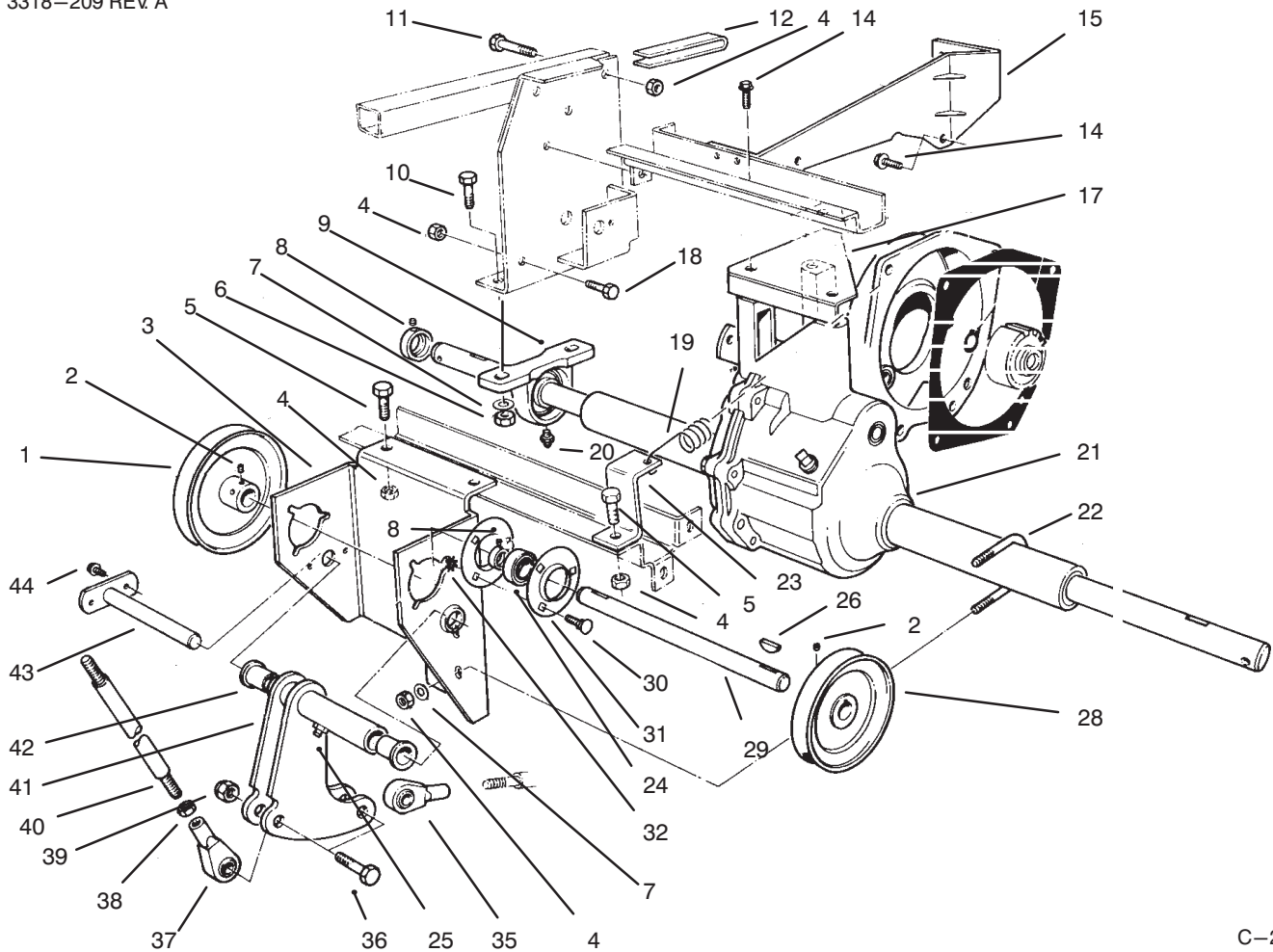

C-2123

DIFFERENTIAL ASSEMBLY

Ref. No.	Part No.	Description	No. Used
1	54-2390	Pulley - Output	1
2	3241-1	Screw - Set	4
3	60-9130	Bracket - Jackshaft	1
4	3296-29	Nut - Lock	A/R
5	322-4	Screw - Hex. Hd.	6
6	3296-44	Nut - Lock	4
7	3256-3	Washer - Flat	6
8	3245-35	Screw - Set	4
9	72-4060	Bearing Assembly	2
10	323-8	Screw - Hex. Hd.	4
11	322-10	Screw - Hex. Hd.	4
12	80-3750	Spacer	2
14	3234-1	Screw - Hex. Flange Hd.	5
15	59-1620	Bracket - Transaxle	1
17	60-8990	Plate - Transaxle	1
18	322-4	Screw - Hex. Hd.	6
19	76-9430	Spring - Extension	1
20	302-2	Fitting - Grease	2
21	13-5969	Differential Assembly	1
22	54-8970	"U" Bolt	1

Ref. No.	Part No.	Description	No. Used
23	92-6273	Bracket - Spring	1
24	251-288	Bearing w/Collar	2
25	302-49	Fitting - Grease	1
26	3257-5	Key - Woodruff	3
28	54-2380	Pulley - Input	1
29	54-1600	Jackshaft	1
30	3230-1	Bolt - Carriage	6
31	251-341	Flange - Bearing	4
32	32149-1	Nut - Lock	6
35	251-304	Rod End	1
36	324-7	Screw - Hex. Hd.	2
37	251-305	Rod End	1
38	3220-4	Nut - Hex. Jam	2
39	3296-48	Nut - Lock	2
40	54-1490	Rod - Steering	1
41	54-2060	Bellcrank Assembly (Incl. Ref. #25 & 42)	1
42	46-6680	Bushing - Flanged	2
43	59-1470	Shaft - Bellcrank	1
44	46-8560	Screw - Thread Forming	2

*Not Illustrated

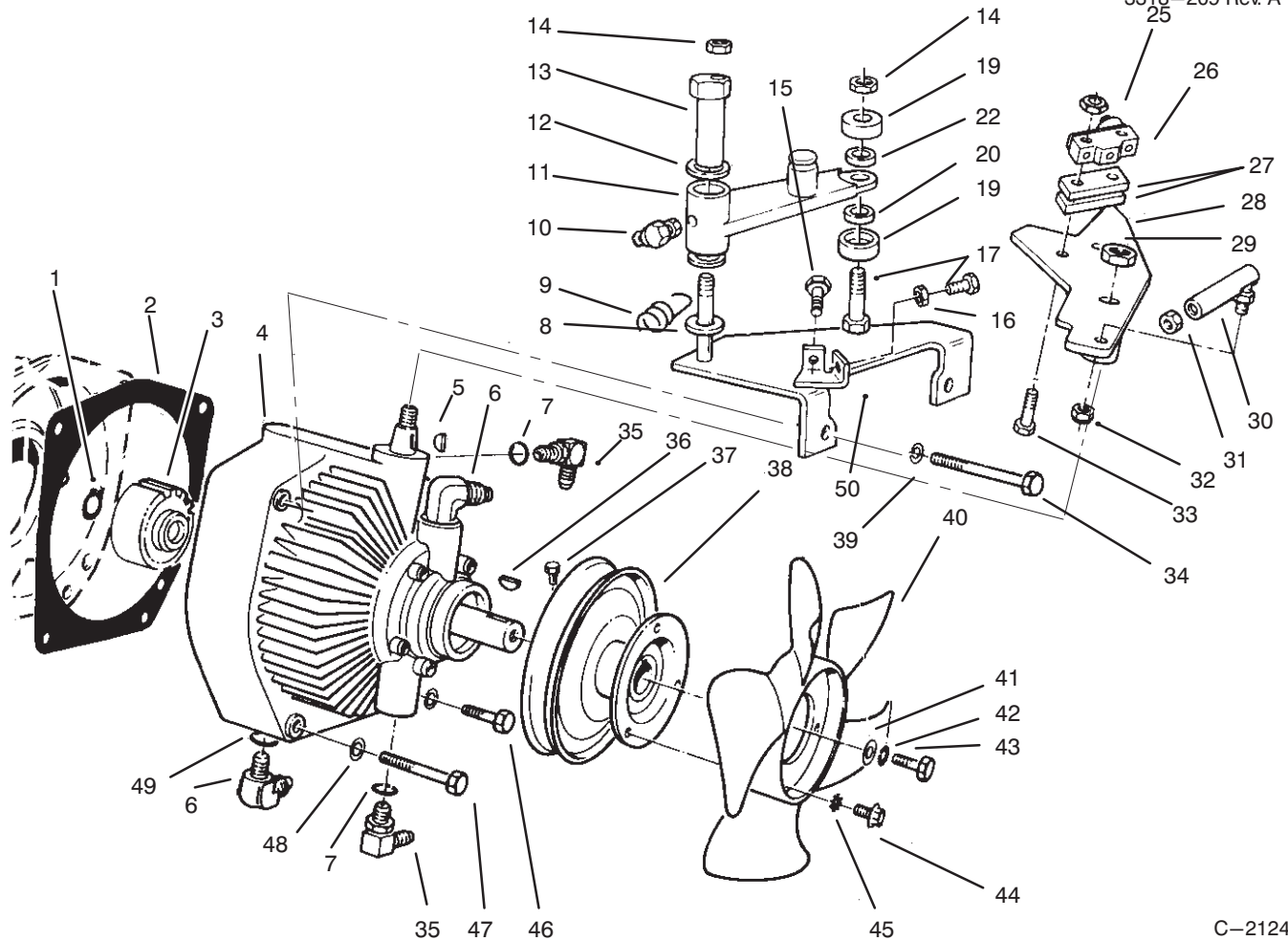

C-2124

TRANSMISSION ASSEMBLY

Ref. No.	Part No.	Description	No. Used
1	32120-64	Ring - Snap	1
2	55-4320	Gasket	
3	54-0320	Gear	1
4	54-0080	Transmission - Hydrostatic	1
5	3257-24	Key - Woodruff	1
6	353-370	Fitting - Hydraulic 90° (Incl. Ref. #49)	2
7	237-79	"O"Ring	2
8	3256-68	Washer	2
9	76-9430	Spring - Extension (Ref.)	
10	302-60	Fitting - Grease 90°	
11	92-6289	Swing Arm Assembly	
*		(Incl. 256-113 Bushings (2))	1
12	3-6498	Washer	1
13	76-8640	Stud - Traction	1
14	3296-29	Nut - Lock	A/R
15	322-6	Screw - Hex. Hd.	2
16	3217-6	Nut	4
17	322-7	Screw - Hex. Hd.	1
19	251-307	Bearing	2
20	92-6290	Spacer	1
22	75-5470	Spacer Bearing	1
25	3296-9	Nut	2
26	29-6163	Switch	1
27	75-4130	Spacer	2

Ref. No.	Part No.	Description	No. Used
28	92-6269	Lever - Traction	2
29	3296-25	Nut	1
30	2411-34	Joint - Ball	1
31	3220-1	Nut - Hex. Jam	1
32	3296-3	Nut - Lock	1
33	3250-46	Screw	2
34	323-14	Screw - Hex. Hd.	1
35	353-511	Fitting - Hydraulic 90° (Incl. Ref. #7)	2
36	3257-5	Key - Woodruff	3
37	3241-2	Screw - Set	2
38	54-0930	Pulley - Transmission	1
39	3253-5	Washer - Lock	4
40	54-0240	Fan	1
41	3256-55	Washer	1
42	3253-3	Washer - Lock	1
43	321-2	Screw - Hex. Hd.	1
44	32144-19	Screw - Round Hd.	3
45	3255-5	Washer - Lock	3
46	323-13	Screw - Hex. Hd.	1
47	323-16	Screw - Hex. Hd.	1
48	3253-5	Washer - Lock	4
49	237-80	"O"Ring	2
50	92-6270	Plate - Traction	1

*Not Illustrated

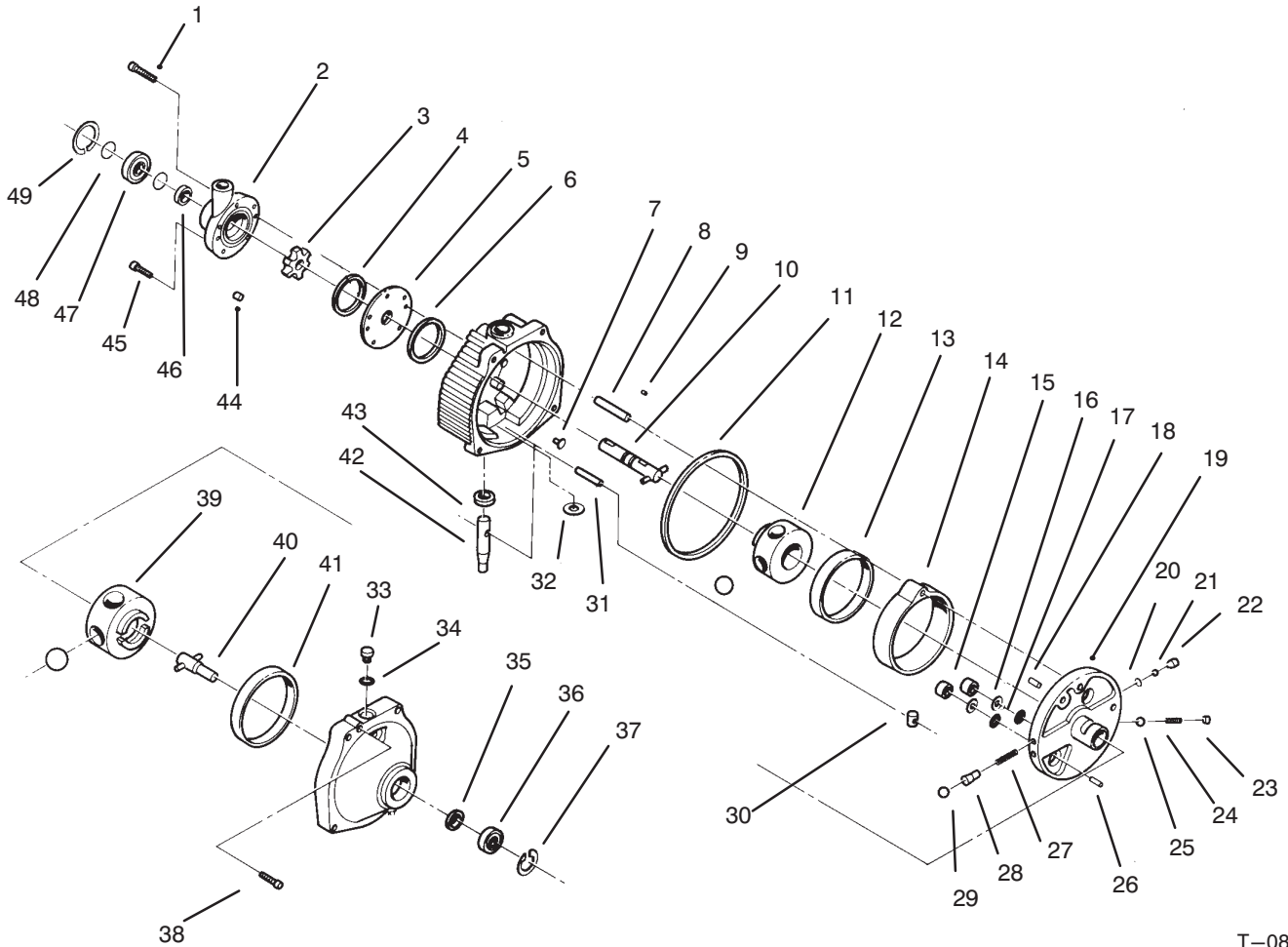

T-0883

HYDROSTATIC TRANSMISSION ASSEMBLY

Ref. No.	Part No.	Description	No. Used
1	56-2800	Screw - Hex. Socket Hd.	1
2	56-2830	Charge Pump Assembly (Incl. Ref. #1)	1
3	56-3120	Carrier	1
4	56-2850	Ring - Seal	1
5	56-2860	Plate - Pump	1
6	56-2870	Ring - Seal	1
7	56-2880	Button	2
8	56-2890	Pin - Dowel	1
9	56-2900	Pin - Drive	1
10	56-2910	Input Shaft Assembly	1
11	56-2920	Ring - Seal	1
12	56-2930	Pump Rotor & Ball Assembly	1
13		Race - Pump	1
14	56-2940	Cam Ring Assembly (Incl. Ref. #13)	1
15	56-2950	Piston	2
16	56-2960	Ring - Backup	2

Ref. No.	Part No.	Description	No. Used
17	56-2970	"O"Ring	2
18	56-2980	Pin - Coil	1
19	56-2990	Pintle Assembly (Incl. Ref. #15-18, 20, 22-26 & 27-29)	1
20	56-3000	Ring - Retaining	2
21	56-3010	Ball	2
22	56-3020	Body - Check Valve	2
23	56-3050	Plug - Relief Valve	1
24	56-3040	Spring - Relief Valve	1
25	56-3030	Ball	1
26	56-3060	Pin - Dowel	1
27	56-3180	Spring - Valve	2
28	56-3200	Body - Valve	2
29	56-3210	Ball	2
30	56-3170	Insert - Cam Ring	1
31		Dowel	1
32		Washer - Control Shaft	1

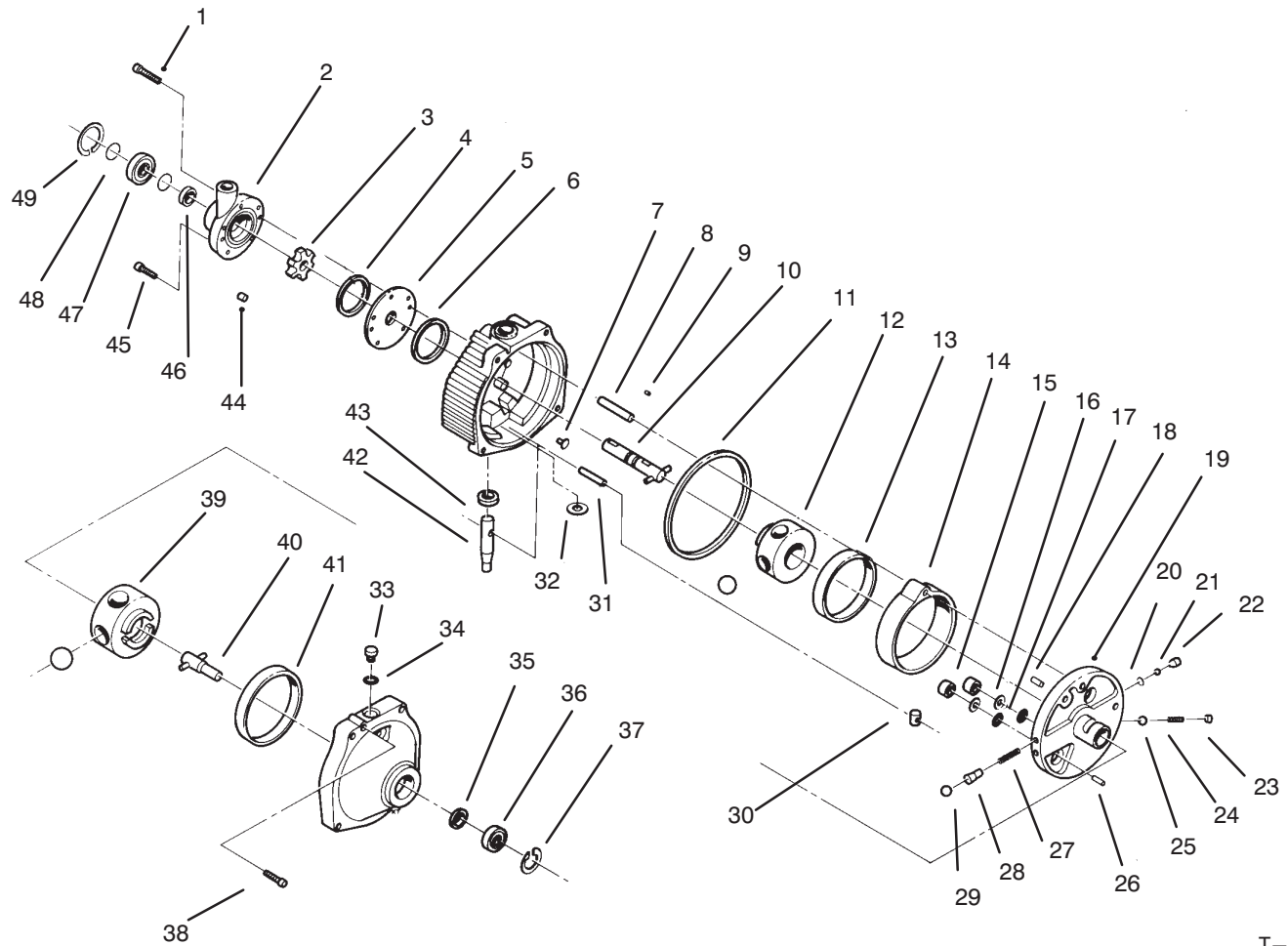

T-0083

HYDROSTATIC TRANSMISSION ASSEMBLY (Continued)

Ref. No.	Part No.	Description	No. Used	Ref. No.	Part No.	Description	No. Used
33	56-3250	Plug Assembly (Incl. Ref. #34)	1	43	56-3130	(Incl. Ref. #31 & 32) Seal - Oil	1
34	56-3260	"O"Ring	1	44	56-3110	Pin - Roll	6
35	56-3270	Seal - Oil	1	45	56-3100	Screw - Hex. Socket Hd.	4
36	56-3280	Bearing - Output	1	46	56-2820	Seal - Oil	1
37	56-3290	Ring - Retaining	1	47	56-2810	Bearing - Input	1
38	56-3300	Screw - Hex. Socket Hd.	2	48	56-3090	Ring - Retaining	2
39	56-3220	Motor Rotor & Ball Assembly	1	49	56-3080	Ring - Retaining	1
40	56-3230	Output Shaft Assembly	1	*	56-3310	Kit - Overhaul Seal (Incl. Ref. #4, 6, 11, 16, 17, 34, 35, 43 & 46)	1
41	56-3240	Race - Motor	1				
42	56-3140	Control Shaft Kit					

DIFFERENTIAL ASSEMBLY NO. 1310-001A

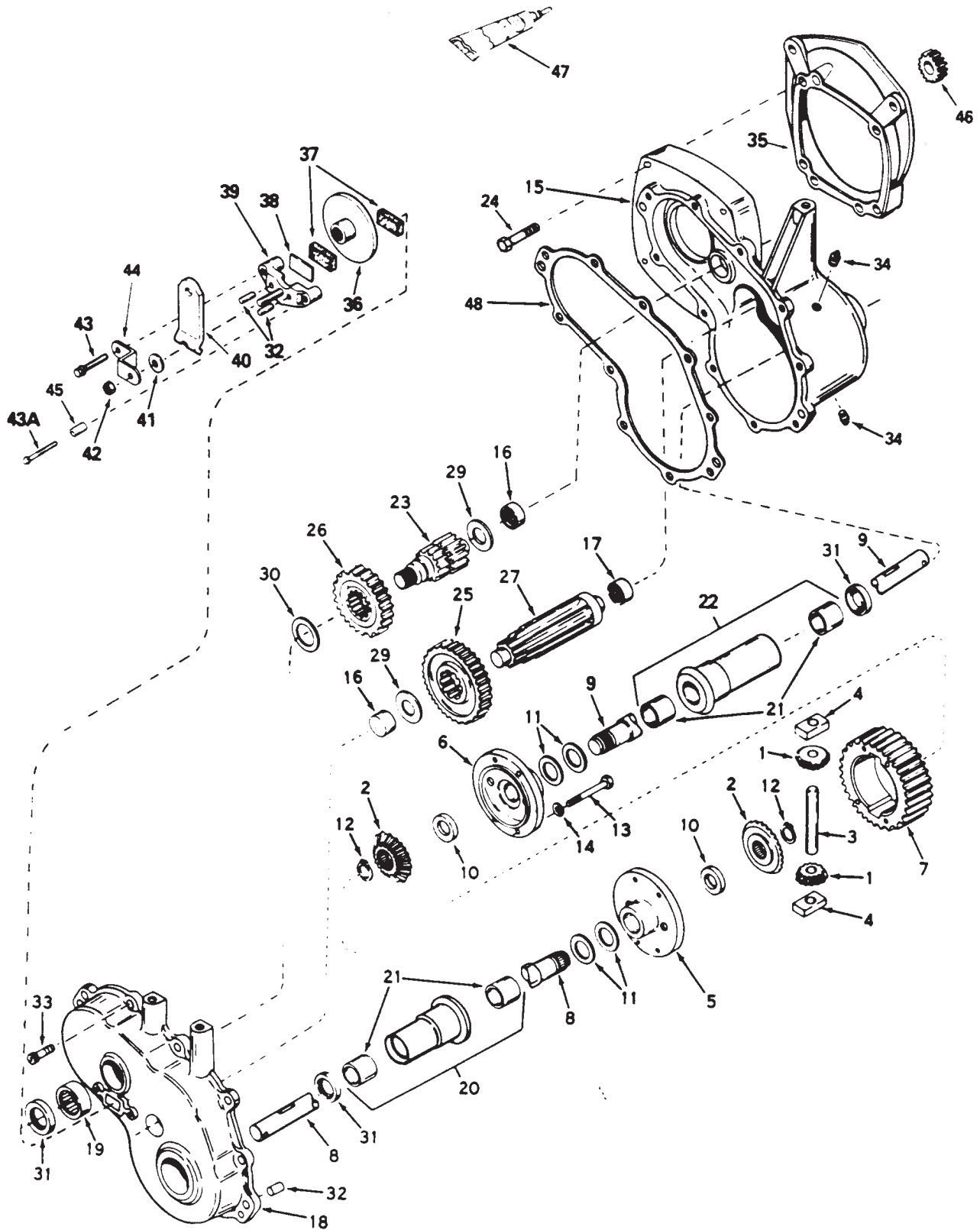

DIFFERENTIAL ASSEMBLY NO. 1310-001A

Ref. No.	Part No.	Description	No. Used	Ref. No.	Part No.	Description	No. Used
1	778197	Pinion – Bevel	1	23	776245	Shaft – Brake	1
2	778198	Gear – Bevel	1	24	79-2120	Screw – Hex. Hd.	1
3	786019	Pin – Drive	1	25	778036	Gear – Output	1
4	786027	Block – Drive	1	26	778037	Gear – Idler	1
5	774028A	Carrier – Differential	1	27	776244	Shaft – Output	1
6	774029A	Carrier – Differential	1	29	780001	Washer	1
7	778033A	Gear – Ring	1	30	780090	Washer	1
8	774607	Axle – 16-5/8"	1	31	788008	Seal – Oil	1
9	774608	Axle – 21-57/64"	1	32	786026	Pin – Dowel	1
10	780107	Washer	1	33	792046	Screw – Thread Forming	1
11	780042	Washer – Thrust	1	34	792010	Plug – Pipe	1
12	792018	Ring – Snap	1	35	786112	Plate – Adapter	1
13	792020	Screw – Hex. Hd.	1	36	790027	Disc – Brake	1
14	792006	Washer – Lock	1	37	790006	Pad – Brake	1
15	770080	Case Assembly (Incl. Ref. #16 & 17)	1	38	790007	Plate – Brake Pad	1
16	780013	Bearing – Needle	1	39	790025	Holder – Brake Pad	1
17	780088	Bearing – Needle	1	40	790010	Lever – Brake	1
18	772085	Cover Assembly (Incl. Ref. #16 & 19)	1	41	792076	Washer – Flat	1
19	780089	Bearing 0 Needle	1	42	792075	Nut – Lock	1
20	782041A	Housing Assembly – 6-5/8" (Incl. Ref. #21)	1	43	792073	Screw – Thread Forming	1
21	780054	Bushing	1	43A	792085	Screw – Thread Forming	1
22	782042A	Housing Assembly – 8-5/8" (Incl. Ref. #21)	1	44	786086	Bracket	1
				45	786066	Spacer	1
				46	778194	Gear – Spur 22T	1
				47	510334	Gasket Eliminator	1
				48	788044	Gasket	1

3318-209

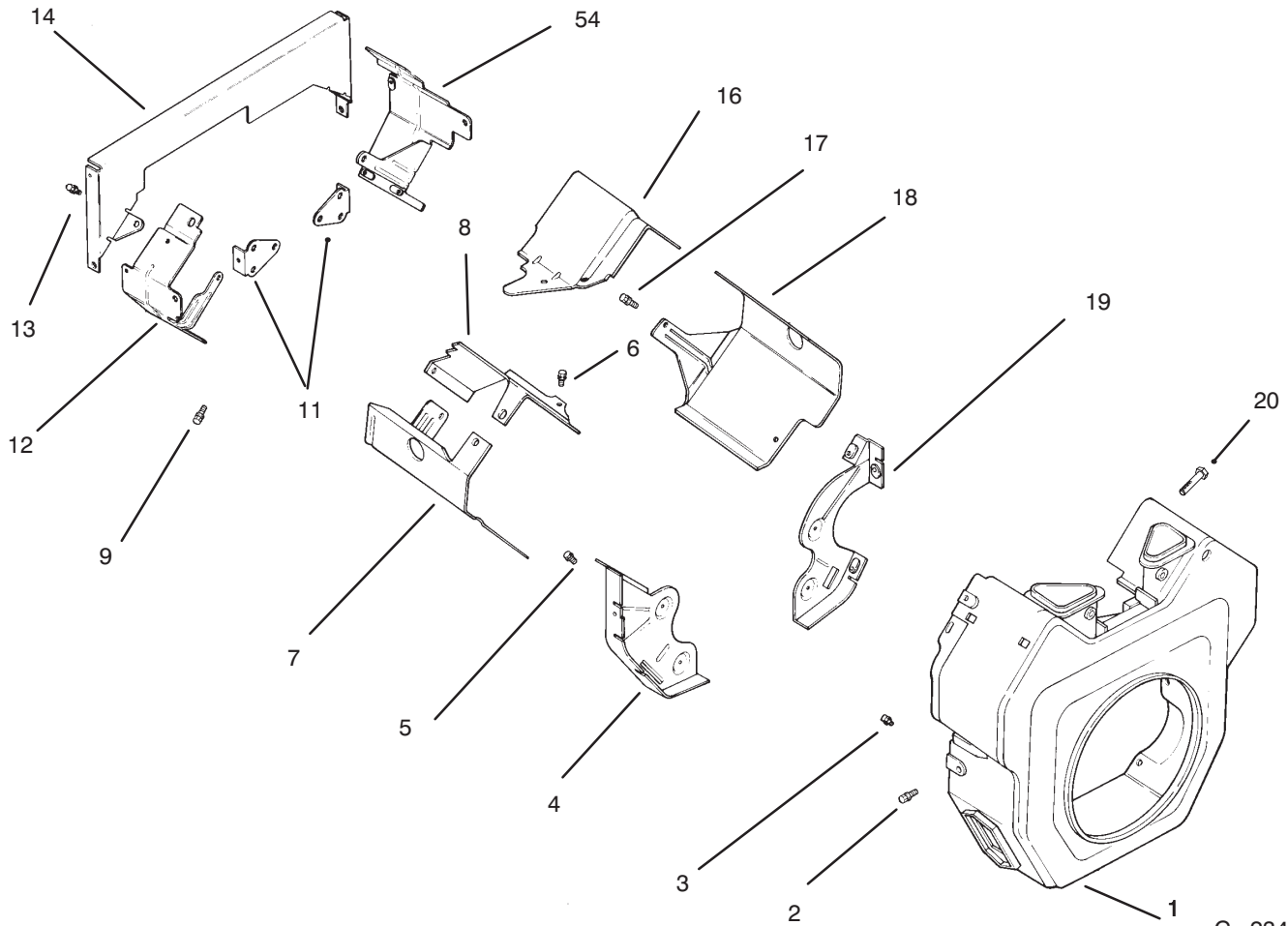

C-2345

BAFFLES & SHROUD

Ref. No.	Part No.	Description	No. Used
1	24 027 21	Housing – Blower	1
2	SM-0545016	Screw	5
3	M-0551016	Screw	1
4	24 146 02	Plate – Backing #2 side	1
5	M-0645016	Screw	4
6	M-0645016	Screw	2
7	24 063 20	Baffle – Cylinder Barrel # 2 side	1
8	24 063 17	Baffle – Valley #2 side	1
9	M-0545010	Screw	2
*10	24 755 14	Kit – "Q" Duct (Incl. Ref. # 11-15)	1
11	24 126 04	Bracket – Support	2

Ref. No.	Part No.	Description	No. Used
12	24 063 12	Baffle, – Ducted Air # 1 side	1
13	M-0639010	Screw	8
14	24 146 04	Plat – Ducted Air Backing	1
15	24 063 13	Baffle – Ducted air # 1 side	1
16	24 063 24	Baffle, Valley 1 side	1
17	SM-0545016	Screw	2
18	24 063 08	Baffle – Cylinder Barrel # 1 side	1
19	24 146 08	Plate – Backing #1 side	1
20	M-0545020	Screw	2

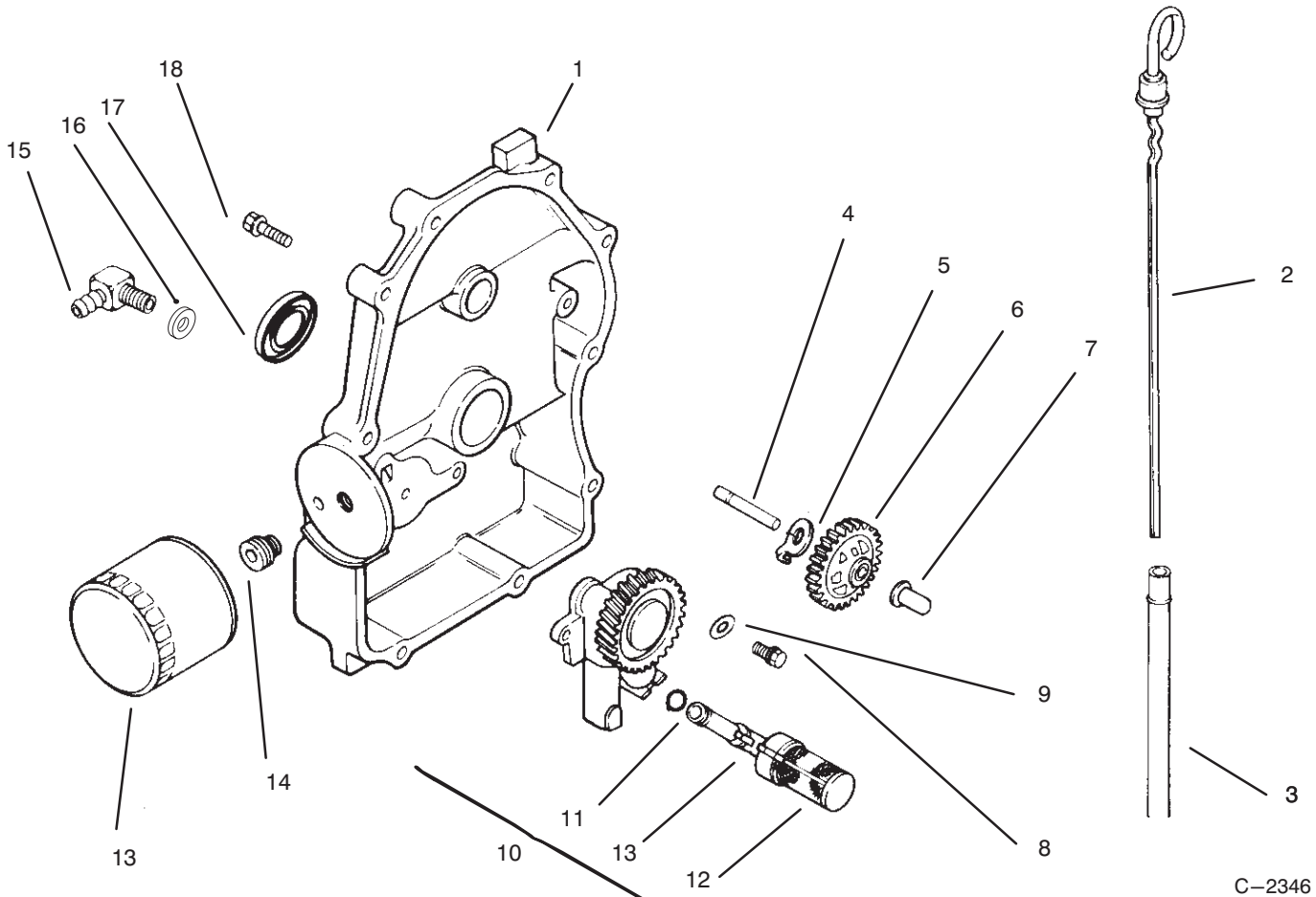

C-2346

OIL PAN/LUBRICATION

Ref. No.	Part No.	Description	No. Used
1	24 009 83	Plate – Closure (Incl. Ref. # 2-7, 10-12, 16 & !7)	1
2	24 038 01	Dipstick	1
3	24 123 04	Tube – Dipstick	1
4	12 144 02	Shaft – Governor Gear	1
5	52 448 02	Tab – Locking	1
6	24 043 12	Kit – Governor Gear Asm (Incl. Ref. # 7)	1
7	12 380 01	Pin – Governor Regulating	1
8	M-0645025	Screw	2
9	M-0631005	Washer – Flat	2

Ref. No.	Part No.	Description	No. Used
10	24 393 03	Oil Pump Assembly (Incl. Ref. # 11-12)	1
11	24 153 01	"O"Ring	1
12	24 381 01	Pick-up, – Oil	1
13	12 050 01	Filter – Oil	1
14	24 136 01	Adapter – Oil Filter	1
15	25 155 02	Connector, – 90° Hose	1
16	24 153 08	"O"Ring	1
17	52 032 08	Seal – Oil (PTO End)	1
18	24 086 16	Screw	10

*Not Illustrated

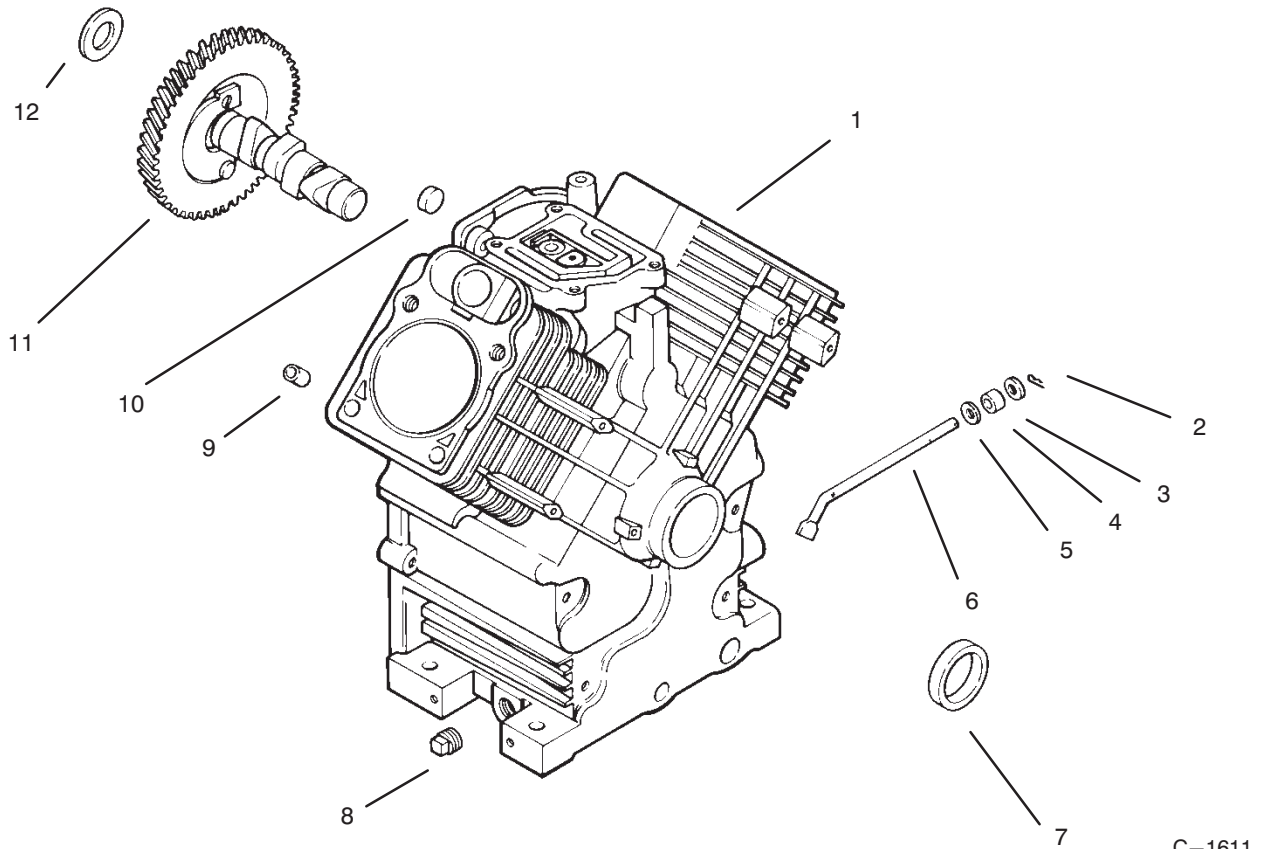

C-1611

CRANKCASE

Ref. No.	Part No.	Description	No. Used
1		Cylinder block (Use Miniblock 24 782 01)	1
2	12 380 04	Pin - Hitch	1
3	X-25-102	Washer - Plain	1
4	12 032 01	Seal - Governor Cross Shaft	1
5	X-25-63	Washer	1
6	24 144 01	Shaft - Governor Cross	1
7	24 032 01	Seal - Oil	1
8	X-75-10	Plug, Sq. Hd.	2
9	12 380 03	Pin - Dowel	6
10	52 139 09	Plug - Cup	1

Ref. No.	Part No.	Description	No. Used
11	24 012 05	Camshaft	1
12	12 422 09	Shim - Camshaft, Green	A/R
*	12 422 13	Shim - Camshaft, Black	A/R
*	12 422 07	Shim - Camshaft, White	A/R
*	12 422 08	Shim - Camshaft, Blue	A/R
*	12 422 10	Shim - Camshaft, Yellow	A/R
*	12 422 11	Shim - Camshaft, Red	A/R
*	12 422 12	Shim - Camshaft, Gray	A/R
*	24 782 01	Short Block	1
*	24 755 03	Set - Gasket	1

*Not Illustrated

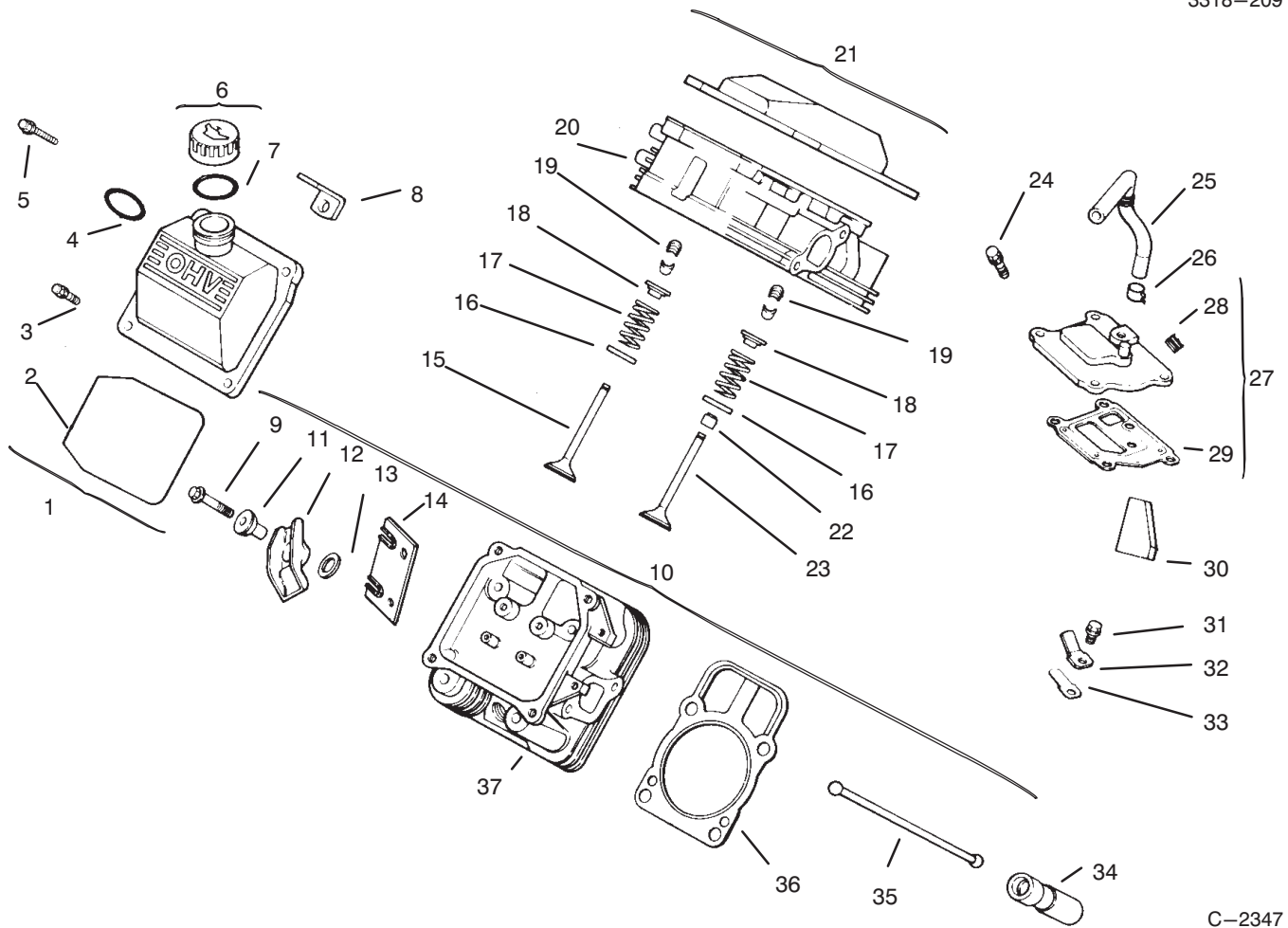

C-2347

CYLINDER HEAD, VALVE & BREATHER

Ref. No.	Part No.	Description	No. Used	Ref. No.	Part No.	Description	No. Used
1	24 755 75	Kit – Valve Cover (Incl. Ref. #2-4)	1	20	24 318 09	Head Assembly (# 1 Cylinder)	1
2	24 153 12	"O"Ring	1	21	24 755 74	Kit – Valve Cover (Incl. Ref. # 2 & 3)	1
3	24 086 32	Screw – Shoulder	4	22	24 032 05	Seal – Valve Stem	2
4	24 153 09	"O"Ring	1	23	24 017 01	Valve – Intake (Std.)	2
5	12 086 16	Screw	8	*	24 017 02	Valve – Intake (.25)	2
6	25 755 13	Kit – Oil Fill Cap (Incl. Ref. #7)	1	24	M-0645020	Screw	4
7	12 153 03	"O"Ring	1	25	24 326 06	Hose – Breather	1
8	24 445 01	Strap – Lifting	1	26	X-426-9	Clamp – Breather	1
9	M-0640034	Screw	4	27	24 033 01	Kit – Breather w/Plug (Incl. Ref. # 28 & 29)	1
10	24 755 61	Kit – Valve Train (Incl. Ref. # 11-14 & 35)	1	28	X-75-23	Plug	1
11	24 194 02	Pivot – Rocker Arm	4	29	24 041 23	Gasket – Breather	1
12	24 186 03	Arm – Rocker	4	30	24 050 01	Filter – Breather	1
13	M-0631005	Washer – Plain	4	31	M-0545010	Screw	1
14	24 146 09	Plate – Guide	2	32	12 018 01	Retainer – Reed	1
15	24 016 01	Valve – Exhaust (Std.)	2	33	24 402 03	Reed	1
*	24 016 02	Valve – Exhaust (.25)	2	34	12 351 01	Lifter – Valve	4
16	235011	Retainer – Spring	4	35	24 411 04	Rod – Push	4
17	24 089 02	Spring – Valve	4	36	24 041 08	Gasket – Cylinder Head	2
18	12 173 01	Cap – Valve Spring	4	37	24 318 10	Head – Assembly (# 2 Cylinder)	2
19	12 755 03	Kit – Retainer	4				

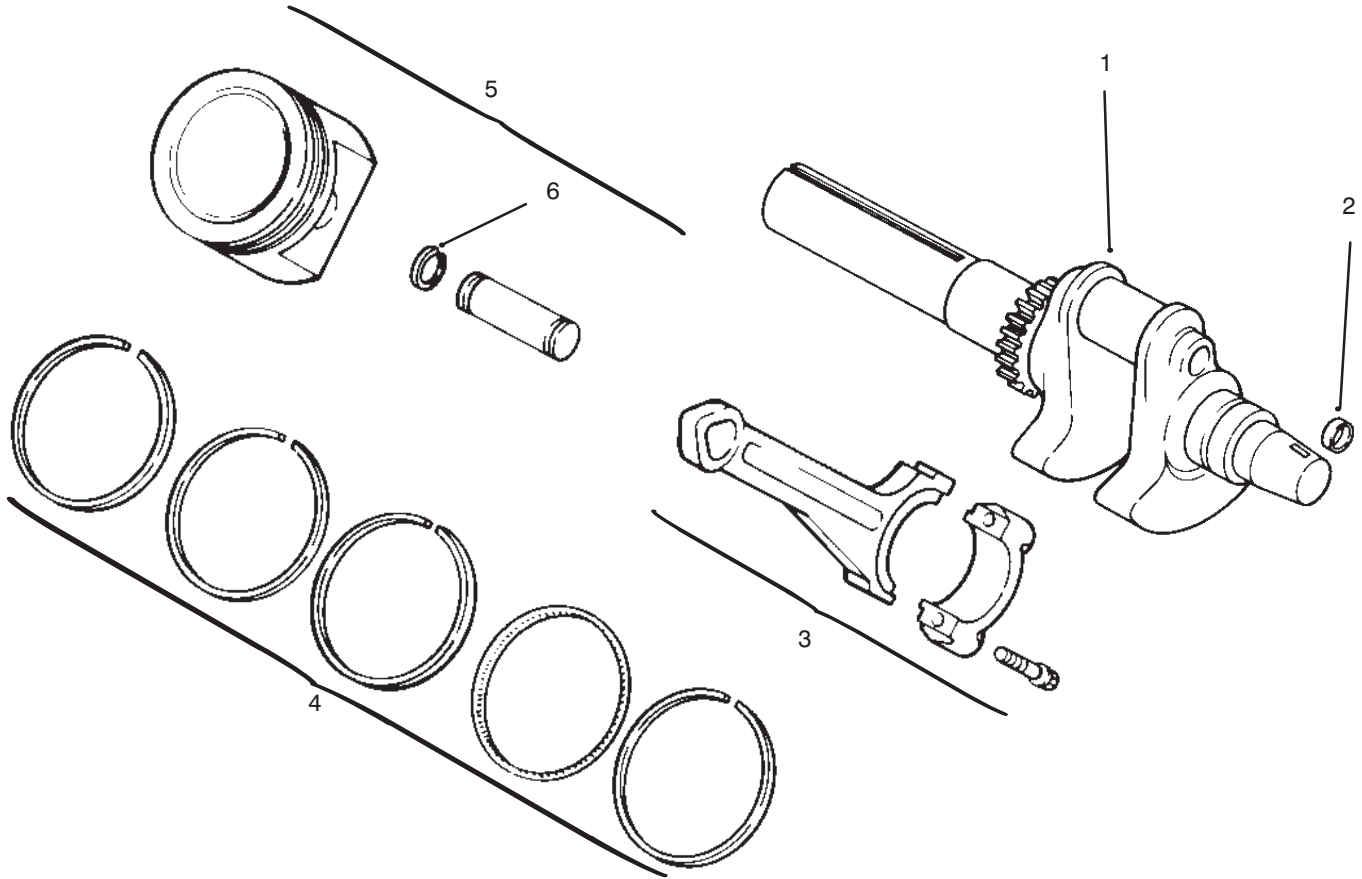

C-1613

CRANKSHAFT, PISTON AND RINGS

Ref. No.	Part No.	Description	No. Used
1	24 014 32	Crankshaft	1
2	12 139 01	Plug, cup	1
3	24 067 05	Connecting Rod (Std.)	2
*	24 067 06	Connecting Rod (.25)	2
4	24 108 01	Ring Set (Std.)	1
*	24 108 02	Ring Set (.25)	1

Ref. No.	Part No.	Description	No. Used
*	24 108 03	Ring Set (.50)	1
5	24 874 01	Piston w/Ring Set (Std.) (Incl. Ref. # 4-6)	2
*	24 874 02	Piston w/Ring Set (.25)	2
*	24 874 03	Piston w/Ring Set (.50)	2
6	24 018 01	Retainer - Piston Pin	4

*Not Illustrated

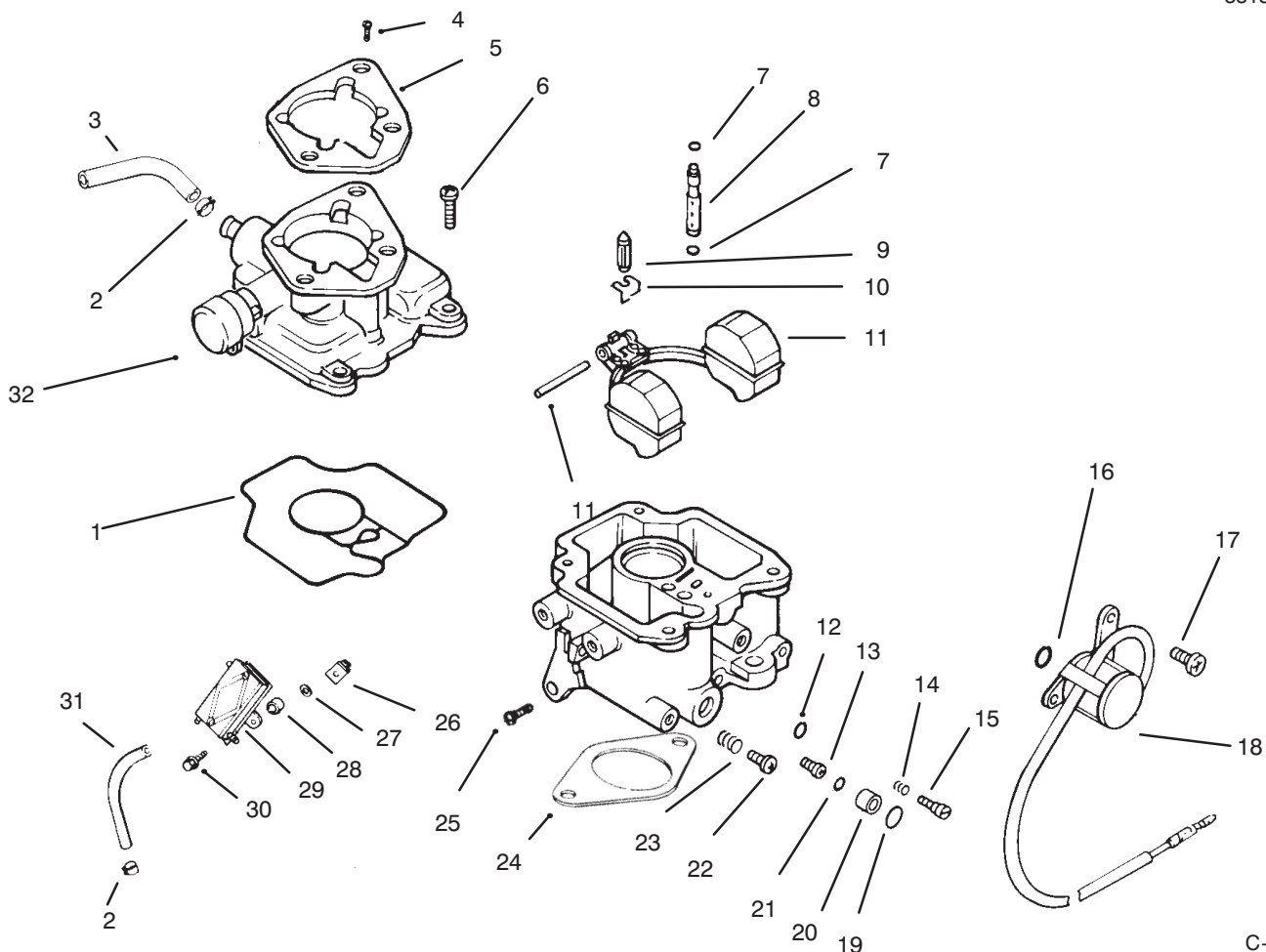

C-2348

CARBURETOR AND FUEL PUMP

Ref. No.	Part No.	Description	No. Used
1	24 041 09	Gasket – Carburetor Body	1
*	24 853 02	Kit – Carburetor w/Gasket (Incl. Ref. #1-15, 19-23 & 29)	1
2	X-426-9	Clamp – Hose	4
3	25 353 10	Line – Fuel 9"	1
4	M-0651030	Screw	2
5	24 041 06	Gasket – Air Cleaner	1
6	24 086 09	Screw	4
7	24 153 02	"O"Ring	2
8	24 337 01	Jet – Slow	1
9	24 462 01	Valve – Inlet Needle	1
10	24 154 01	Clip – Inlet Needle Valve	1
11	24 757 02	Kit – Float Repair	1
12	24 153 03	"O"Ring	1
13	24 337 02	Jet – Main	1
14	24 089 11	Spring – Idle Adjust	1
15	24 368 01	Needle – Idle Adjust	1
16	24 153 04	"O"Ring	1
17	24 086 07	Screw	2
18	24 435 01	Solenoid	1
19	24 153 05	"O"Ring	1
20	24 521 01	Seat – Solenoid	1

Ref. No.	Part No.	Description	No. Used
21	24 153 06	"O"Ring	1
22	24 086 10	Screw – Idle Speed Adjust	1
23	24 089 10	Spring – Idle Speed Adjust	1
24	24 041 17	Gasket – Carburetor	1
25	24 086 05	Screw – Throttle Stop	1
26	24 100 01	Nut	2
27	X-25-52	Washer	2
28	52 112 13	Spacer	2
29	24 393 04	Pump – Fuel, Pulse	1
30	24 086 31	Screw	2
31	24 353 02	Line – Fuel 15-1/2"	1
32	24 757 07	Kit – Choke Repair (Incl. Ref. # 33)	1
*33	24 173 02	Cap – Choke Lever	1
*		Carburetor Assembly (Incl. Ref. # 1-25 & 32)	1
*	24 041 17	Gasket – Carburetor	1
*	24 757 03	Kit – Carburetor Repair	1
*	24 757 01	Kit – Solenoid Assembly	1
*	24 755 01	Kit – High Altitude (1500 meters)	1
*	24 755 02	Kit – High Altitude (3000 meters)	1

*Not Illustrated

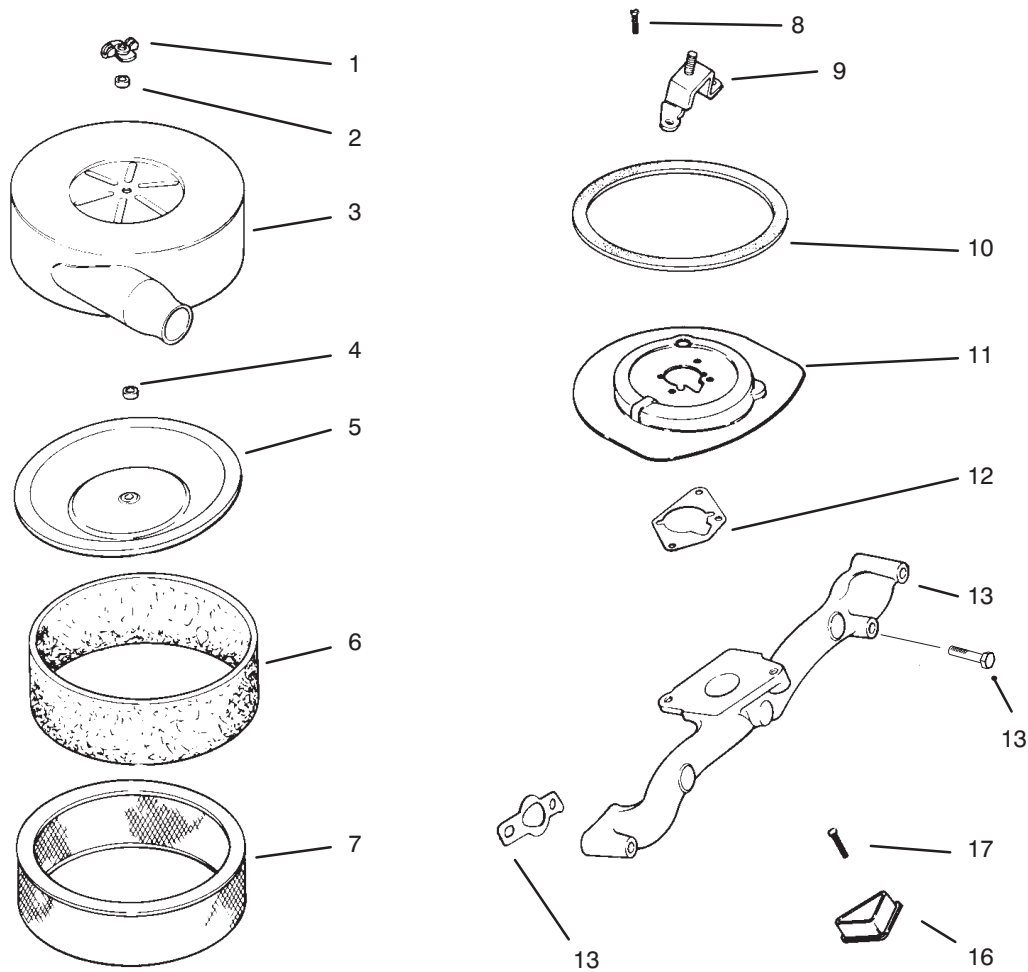

C-2349

AIR INTAKE/FILTRATION

Ref. No.	Part No.	Description	No. Used
1	12 100 01	Nut – Wing	2
2	230046	Seal – Air Filter	1
3	24 096 34	Cover – Air Cleaner	1
4	231032	Seal – Breather	1
5	24 096 01	Cover – Inner Air Cleaner	1
6	24 083 02	Element – Precleaner	1
7	47 083 03	Element – Air Cleaner	1
8	M-0639016	Screw	3
9	24 126 22	Bracket – Air Cleaner	1

Ref. No.	Part No.	Description	No. Used
10	24 032 07	Seal – Air Cleaner	1
11	24 094 05	Base – Air Cleaner	1
12	24 041 06	Gasket – Air Cleaner	1
13	24 041 01	Gasket – Intake Manifold	2
14	M-0639055	Screw	4
15	24 164 14	Manifold	1
16	24 096 17	Cover – Blower Housing	2
17	15 086 09	Screw	2
*	24 113 17	Decal – Maintenance	1

*Not Illustrated

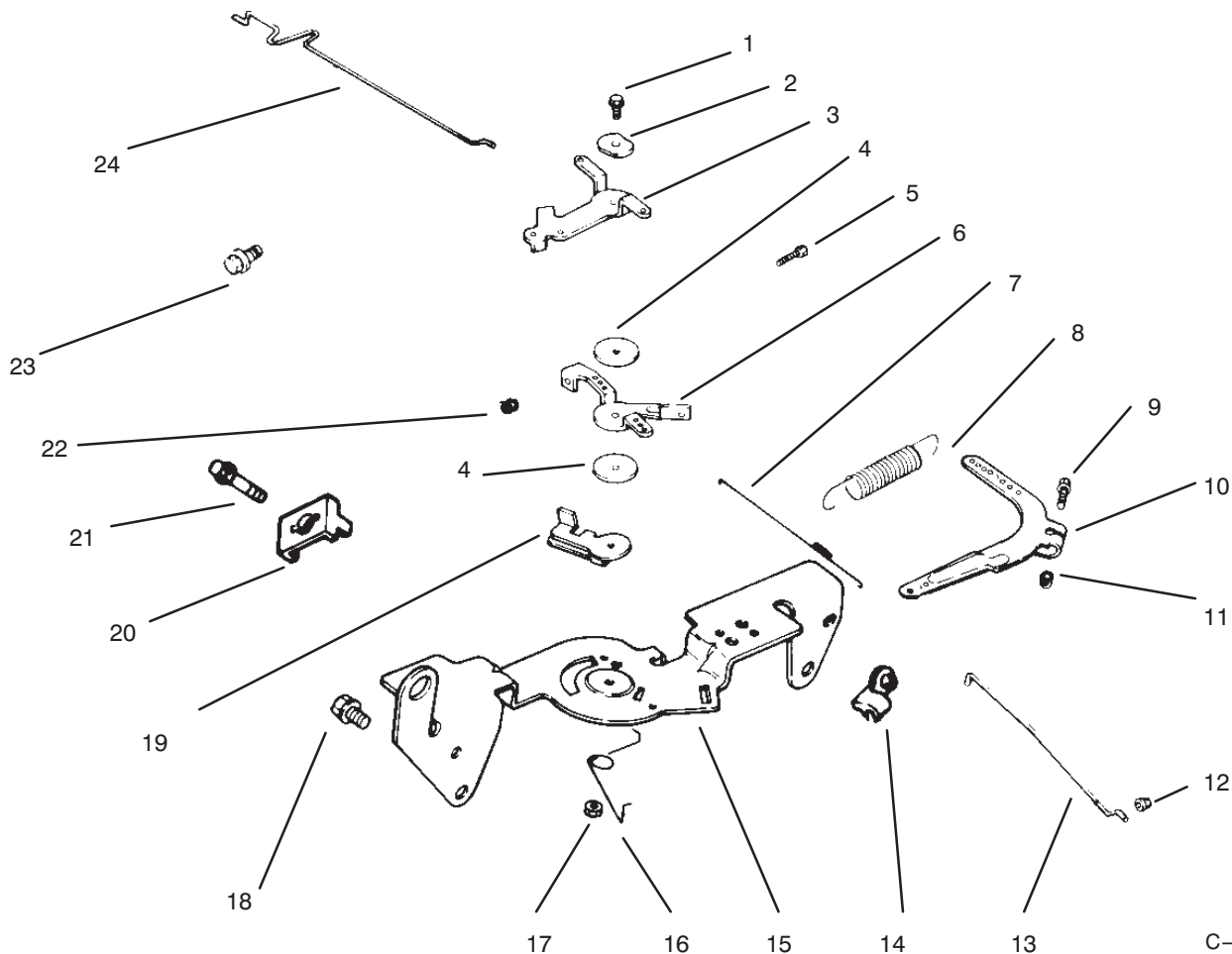

C-1615

THROTTLE LINKAGE AND GOVERNOR CONTROLS

Ref. No.	Part No.	Description	No. Used	Ref. No.	Part No.	Description	No. Used
1	SM-0545020	Screw	1	13	24 079 01	Linkage – Throttle	1
2	41 468 03	Washer – Wave	1	14	25 158 11	Bushing – Linkage	1
3	24 090 05	Lever – Choke	1	15	24 126 13	Bracket – Control	1
4	24 468 01	Washer	3	17	M-0547050	Nut	1
5	M-0401025	Screw	1	16	24 089 03	Spring – Choke Return	1
7	24 089 01	Spring – Linkage	1	18	SM-0645016	Screw	4
6	24 090 03	Lever – Throttle Control	1	19	24 090 07	Lever – Throttle Actuator	1
8	24 089 18	Spring – Governor	1	20	12 237 01	Clamp – Cable	2
9	SM-0642025	Screw	1	21	SM-0545016	Screw	2
10	24 090 14	Lever – Governor	1	22	M-0446030	Nut	1
11	SM-0641060	Nut	1	23	SM-0545016	Screw	1
12	25 158 08	Bushing – Linkage	1	24	24 079 02	Linkage – Choke	1

*Not Illustrated

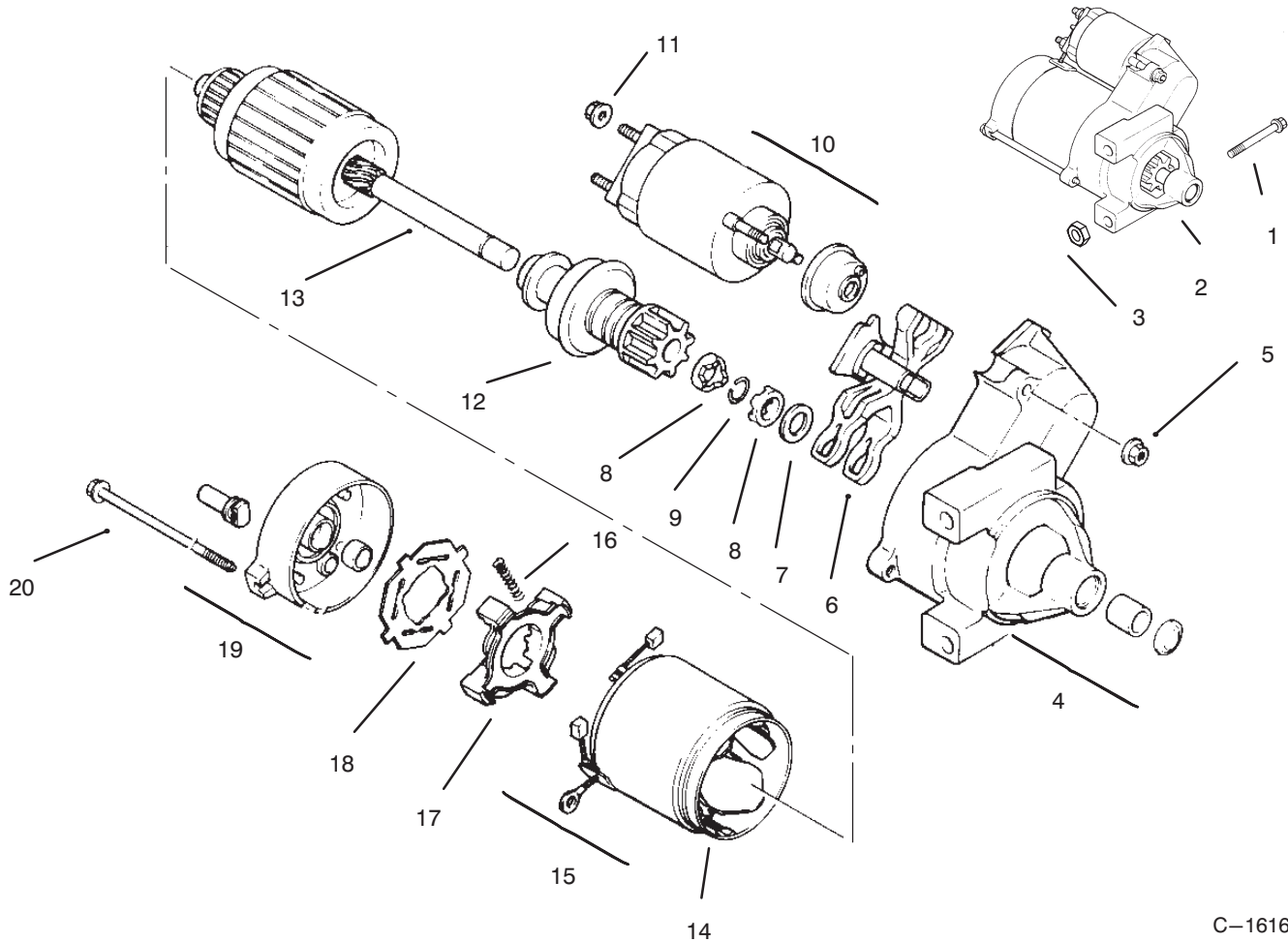

C-1616

STARTER

Ref. No.	Part No.	Description	No. Used
1	SM-0839080	Screw	2
2	24 098 01	Starter - Solenoid Shift (Incl. Ref. # 4-20)	1
3	M-0841080	Nut	1
4	24 081 04	Cap - Drive End	1
5	52 100 10	Nut - Starter	2
6	12 090 10	Lever - Starter Drive	1
7	52 468 14	Washer - Thrust	1
8	52 100 08	Nut - Stop Collar	2
9	52 141 03	Ring - Retainer	1
10	52 435 02	Solenoid	1

Ref. No.	Part No.	Description	No. Used
11	52 100 09	Nut	1
12	12 239 01	Drive - Pinion	1
13	12 170 03	Armature - Starter	1
14	12 471 01	Frame	1
15	52 221 01	Kit - Brush (Incl. Ref. # 16)	1
16	52 089 09	Spring - Brush	4
17	52 323 03	Holder - Brush	1
18	52 168 01	Insulator	1
19	12 301 01	Cap - Commutator End	1
20	52 211 05	Bolt	2

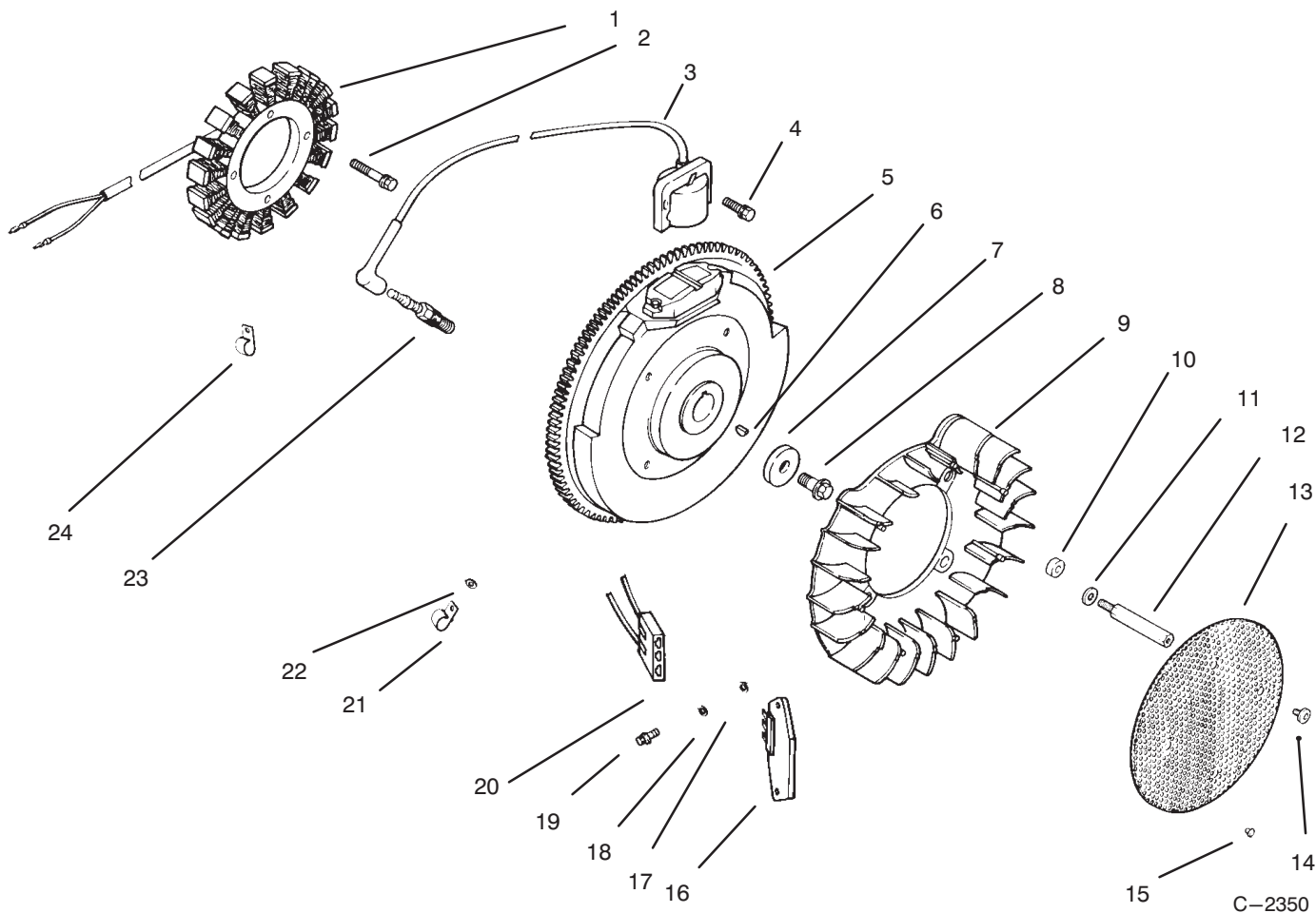

C-2350

IGNITION AND CHARGING SYSTEM

Ref. No.	Part No.	Description	No. Used	Ref. No.	Part No.	Description	No. Used
1	24 085 01	Stator – 15 amp	1	14	M-0657010	Screw	4
2	M-0548025	Screw	2	15	25 086 43	Screw – Set	1
3	24 584 01	Module – Ignition	2	16	25 403 03	Regulator – Rectifier	1
4	SM-0545020	Screw	4	17	X-25-63	Washer	1
5	24 025 01	Flywheel Assembly	1	18	X-25-92	Washer	2
6	X-42-15	Key	1	19	24 086 18	Screw	2
7	12 468 03	Washer	1	20	236602	Connector	1
8	12 086 14	Screw	1	21	235173	Clip – Cable	1
9	24 157 01	Fan	1	22	X-25-63	Washer	1
10	12 112 01	Spacer – Fan	4	23	12 132 02	Spark Plug	2
11	X-25-53	Washer	4	24	48 154 02	Clip – Cable	1
12	24 072 01	Stud – Grass Screen	4	*	24 176 40	Harness – Wiring	1
13	24 162 13	Screen – Grass	1	*	24 518 04	Lead – Green,18 Gauge	1

*Not Illustrated

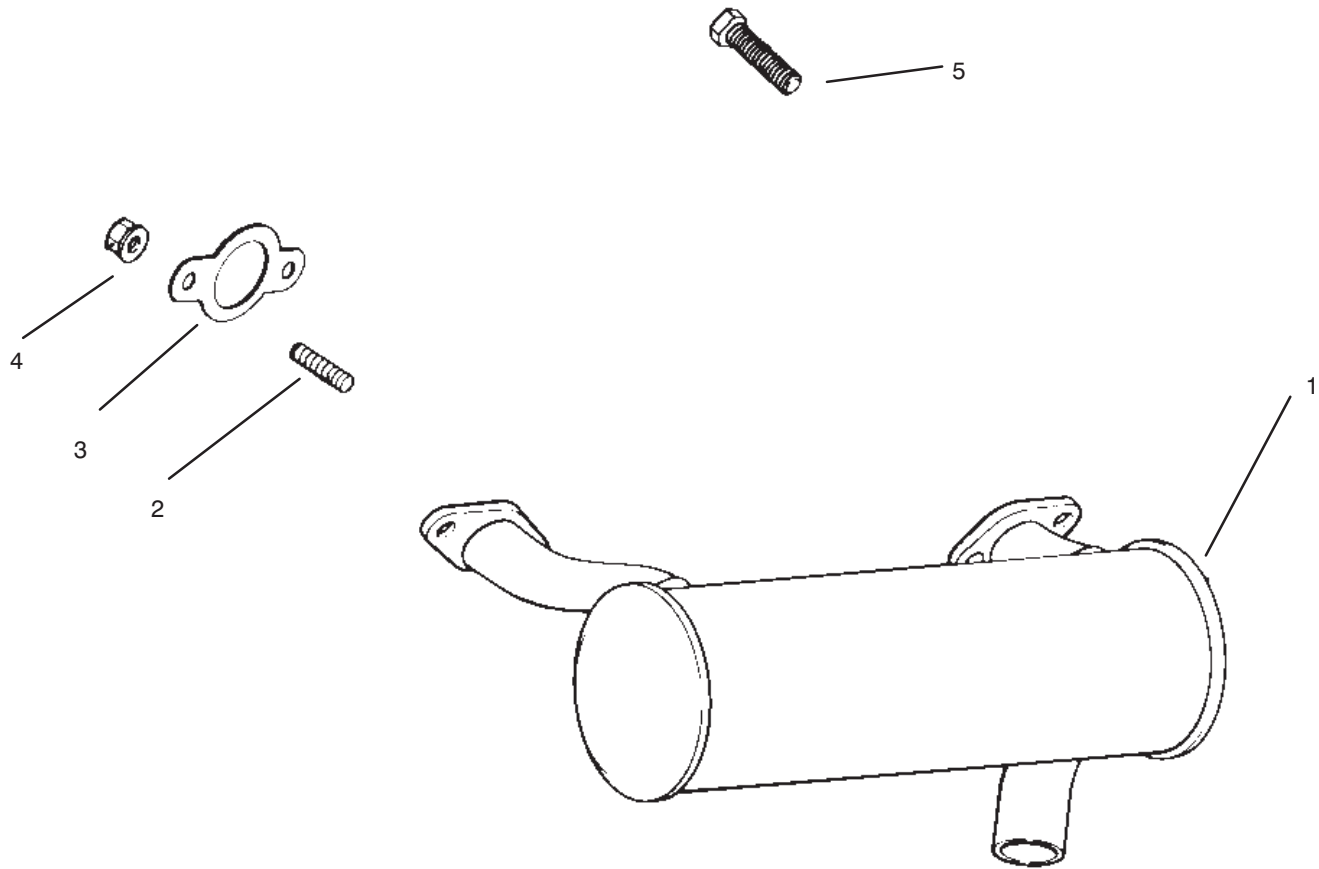

C-1618

EXHAUST

Ref. No.	Part No.	Description	No. Used
1	24 068 11	Muffler	1
2	M-0829033	Stud - Muffler	4
3	24 041 02	Gasket - Exhaust	2

Ref. No.	Part No.	Description	No. Used
4	M-0841080	Nut	4
5	M-0839020	Screw	1

TORO PART NUMBER INDEX

Part No.	Description	Pg. Ref. No. No. Qty.	Part No.	Description	Pg. Ref. No. No. Qty.
102950	Washer	2 72 1	46-6680	Bushing	3 9 6
105805	Nut	2 73 1	46-6680	Bushing - Flanged	18 42 2
109989	Spacer	9 3 4	46-7510	Hood - Intake	7 10 1
113050	Cover - P.T.O. Switch	2 39 1	46-8091	Screw	13 42 2
113179	Nut	2 38 1	46-8560	Screw	5 35 7
114263	Spring - Seat	9 9 2	46-8560	Screw - Hex. Hd.	1 5 25
116716	Switch - Clutch & Brake	2 41 1	46-8560	Screw - Thread Forming	18 44 2
3-6498	Washer	19 12 1	47-1980	Cover Steering Shaft	2 31 1
3-6498	Washer - Thrust	3 8 5	48-7610	Screw	14 4 5
3-6498	Washer - Thrust	2 52 2	49-6430	Pad - Reverse	1 12 1
5-0930	Key	14 21 1	49-6470	Pad - Accelerator	1 4 1
11-4659	Air Cleaner Assembly	8 27 1	51-0780	Slide Seat Assembly R.H.	9 * 1
12-1109	Lever - Idler	11 27 1	51-0790	Slide Seat Adjust Assembly	9 2 1
12-5950	Rod - Battery Support	13 18 1	54-0080	Transmission - Hydrostatic	19 4 1
13-5969	Differential Assembly	18 21 1	54-0090	Valve Assembly	8 23 1
14-4109	Hood	13 3 1	54-0100	Filter Head Assembly	6 63 1
19-1470	Bolt - Shoulder	5 41 2	54-0110	Filter - Transmission Oil	5 44 1
21-9260	Cover - Dust	1 21 1	54-0140	Hub - Wheel	4 2 2
22-8330	Plug	10 19 1	54-0150	Cylinder - Lift	11 18 1
22-8340	Spring	10 21 1	54-0220	Assembly - Clutch	14 16 1
22-8350	Ball	10 22 1	54-0230	Field Assembly	15 1 1
22-8360	Pin - Cam	10 24 1	54-0240	Fan	19 40 1
22-8370	Seat - Check Valve	10 23 1	54-0260	Spool	10 1 1
22-8380	Retainer - Spring	10 3 2	54-0280	Shaft	12 13 1
22-8410	Spring	10 4 1	54-0290	Seal Repair Kit	12 * 1
22-8480	Ring - Retaining	10 6 1	54-0300	Piston	12 3 1
22-8490	Ring - Retaining	10 7 1	54-0310	Head	12 6 1
22-8500	"O"Ring	10 2 2	54-0320	Gear	19 3 1
23-1120	Washer - Flat	6 58 2	54-0330	Frame - Rear	3 13 1
24-5790	Weight - Rear	3 17 1	54-0450	Axle Stand R.H.	6 60 1
27-0410	Bolt - Shoulder	5 28 2	54-0460	Axle Stand - L.H.	5 39 1
27-5200	Spacer	10 5 1	54-0560	Spindle L. H.	3 22 1
27-6230	Bolt - Shoulder	11 31 1	54-0570	Spindle R.H.	3 7 1
27-9080	Bushing	1 1 3	54-0930	Pulley - Transmission	19 38 1
27-9080	Bushing	11 6 4	54-0960	Spring - Parking Brake	11 42 1
27-9080	Bushing	3 31 2	54-1000	Tower - Top	1 24 1
28-1120	Plug	10 18 1	54-1010	Channel - Front	5 45 1
28-2480	Washer - Flat	3 2 2	54-1060	Bracket - Idler Mount	6 55 1
28-3894	Wire - Positive	14 29 1	54-1120	Bracket - Filter Head	6 64 1
28-3940	Collar - Steering Shaft	2 45 2	54-1130	Link - Idler Anchor	5 22 2
29-0590	Screen	13 35 1	54-1170	Spring - Extension	11 30 1
29-6163	Switch	19 26 1	54-1220	Support - Seat R.H.	8 8 1
33-1300	Element Assembly	7 6 1	54-1260	Clamp - Battery	13 9 1
33-1310	Baffle	7 5 1	54-1270	Bracket - Parking Brake	11 8 1
33-1320	Cup	7 4 1	54-1340	Link - Steering	2 43 1
33-1330	Nut Assembly	7 3 1	54-1380	JackShaft - VBelt	5 40 1
33-1340	Clamp Assembly	7 2 1	54-1380	V-Belt	14 17 1
33-1350	Band Assembly	7 1 2	54-1390	VBelt - Traction	6 59 1
36-3220	Pulley - Idler	11 26 1	54-1390	V-Belt	14 18 1
36-4950	Cap - Oil	13 36 1	54-1410	Spring - Idler	5 21 2
37-7250	Spacer	6 53 2	54-1440	Bracket - Tunnel	2 50 2
38-8000	Filter - Fuel	13 26 1	54-1451	Control - Throttle, Choke	1 25 2
43-5220	Ring - Retaining	12 12 1	54-1470	Footrest - L.H.	2 63 1
44-8160	Washer - Flat	14 14 1	54-1490	Rod - Steering	18 40 1
44-8310	Ring - Retaining	15 3 2	54-1491	Rod - Steering, Rear	3 29 1
44-8320	Spring	15 10 3	54-1550	Support - Hood	8 30 1
44-8330	Spacer - Bearing	15 6 1	54-1600	Jackshaft	18 29 1
44-8340	Collar - Bearing	15 7 1	54-1770	Bracket - Cable Traction	2 64 1
44-8360	Field Coil, Rotor & Bearing	15 4 1	54-1800	Plate - Engine Front	5 8 2
44-8370	Armature & Pulley Assembly	15 5 1	54-1810	Plate - Engine, Rear	5 11 2

*Not Illustrated

TORO PART NUMBER INDEX (Cont.)

Part No.	Description	Pg. Ref. No. No. Qty.	Part No.	Description	Pg. Ref. No. No. Qty.
54-1420	Shaft - Steering	2 30 1	56-2900	Pin - Drive	20 9 1
54-1830	Support - Shield	5 25 1	56-2910	Input Shaft Assembly	20 10 1
54-1850	Support - Battery	13 16 1	56-2920	Ring - Seal	20 11 1
54-1860	Stop - Hood Upper	13 6 2	56-2930	Pump Rotor & Ball Assembly	20 12 1
54-1870	Stop - Hood, Lower	5 31 2	56-2940	Cam Ring Assembly	20 14 1
54-1880	Strap - Fuel Tank	13 4 2	56-2950	Piston	20 15 2
54-1890	Foam - Tank	13 20 2	56-2960	Ring - Backup	20 16 2
54-1900	Tower - Front	1 3 1	56-2970	"O"Ring	20 17 2
54-1910	Channel - Side R.H.	5 6 1	56-2980	Pin - Coil	20 18 1
54-1920	Channel - Side L.H.	5 33 1	56-2990	Pintle Assembly	20 19 1
54-1930	Fender R.H.	5 1 1	56-3000	Ring - Retaining	20 20 2
54-1940	Fender L.H.	5 36 1	56-3010	Ball	20 21 2
54-1950	Bracket - Support Bearing	1 22 2	56-3020	Body - Check Valve	20 22 2
54-2000	Pin - Pivot	11 13 1	56-3030	Ball	20 25 1
54-2040	Follower Lever	2 54 1	56-3040	Spring - Relief Valve	20 24 1
54-2060	Bellcrank Assembly	18 41 1	56-3050	Plug - Relief Valve	20 23 1
54-2070	Anchor - Spring	5 18 1	56-3060	Pin - Dowel	20 26 1
54-2100	Pin - Pivot	11 39 2	56-3080	Ring - Retaining	21 49 1
54-2110	Lever - Brake	11 2 1	56-3090	Ring - Retaining	21 48 2
54-2120	Link - Parking Brake	11 1 1	56-3100	Screw - Hex. Socket Hd.	21 45 4
54-2160	Bracket - Anchor	14 10 1	56-3110	Pin - Roll	21 44 6
54-2260	Pad Footrest L.H.	2 62 1	56-3120	Carrier	20 3 1
54-2270	Pad - Footrest R.H.	2 68 1	56-3130	Seal - Oil	21 43 1
54-2290	Pipe - Exhaust	14 13 1	56-3140	Control Shaft Kit	21 42 1
54-2310	Hydraulic Tube Assembly	17 2 1	56-3170	Insert - Cam Ring	20 30 1
54-2310	Hydraulic Tube Assembly	13 28 1	56-3180	Spring - Valve	20 27 2
54-2330	Pulley - Engine	14 19 1	56-3200	Body - Valve	20 28 2
54-2380	Pulley - Input	18 28 1	56-3210	Ball	20 29 2
54-2390	Pulley - Output	18 1 1	56-3220	Motor Rotor & Ball Assembly	21 39 1
54-2470	Reservoir - Hydraulic	13 34 1	56-3230	Output Shaft Assembly	21 40 1
54-2500	Channel - Middle	5 19 1	56-3240	Race - Motor	21 41 1
54-2570	Hydraulic Hose Assembly	17 4 1	56-3250	Plug Assembly	21 33 1
54-2580	Hydraulic Hose Assembly	17 3 1	56-3260	"O"Ring	21 34 1
54-2590	Hydraulic Hose Assembly	17 7 1	56-3270	Seal - Oil	21 35 1
54-2610	Hydraulic Hose Assembly	17 5 1	56-3280	Bearing - Output	21 36 1
54-2620	Hydraulic Hose Assembly	17 6 1	56-3290	Ring - Retaining	21 37 1
54-2630	Follower - Steering Shaft	2 53 1	56-3300	Screw - Hex. Socket Hd.	21 38 2
54-2640	Cable - Traction Control	2 44 1	56-3310	Kit - Overhaul Seal	21 * 1
54-1310	Hinge - Seat	8 3 1	56-3320	THook	11 20 1
54-8970	UBolt	18 22 1	56-3370	Bracket - Spring	11 22 2
54-9200	Lever - Idler	6 52 2	56-3390	Hydraulic Hose Assembly	17 1 1
55-3570	Cap - Fuel	13 2 1	56-6590	Screw	8 14 1
55-3630	Adjustable Relief Valve	10 * 1	56-6920	Bracket - Cable Extension	11 40 1
55-3640	Seat - Relief	10 8 1	57-3100	Tie Rod - Steering	3 35 2
55-3650	Plug	10 26 1	59-1470	Shaft - Bellcrank	18 43 1
55-4320	Gasket	19 2	59-1500	Pivot - Axle	3 19 1
55-4860	Guide - Belt	5 37 1	59-1550	Pedal - Shaft	2 65 1
55-7120	Switch - Brake	11 9 1	59-1610	Tube - Grease Fitting	1 14 1
55-7310	Bracket - Idler	11 34 1	59-1620	Bracket - Transaxle	18 15 1
55-8660	Assembly - Clamp	14 9 1	60-8990	Plate - Transaxle	18 17 1
56-2760	Spring - Extension	11 21 2	60-9050	Bearing - Steering Shaft	2 46 1
56-2800	Screw - Hex. Socket Hd.	20 1 1	60-9130	Bracket - Jackshaft	18 3 1
56-2810	Bearing - Input	21 47 1	60-9140	Frame - Footrest	2 51 1
56-2820	Seal - Oil	21 46 1	60-9150	Tunnel	2 66 1
56-2830	Charge Pump Assembly	20 2 1	61-9780	Hub Cap	3 1 2
56-2850	Ring - Seal	20 4 1	62-4040	Tank - Fuel	13 15 1
56-2860	Plate - Pump	20 5 1	62-4420	Spacer	3 32 9
56-2870	Ring - Seal	20 6 1	62-4530	Idler - VBelt	5 43 2
56-2880	Button	20 7 2	62-4540	Idler - Flat	6 56 2
56-2890	Pin - Dowel	20 8 1	62-7400	Decal - Toro	2 70 1

*Not Illustrated

TORO PART NUMBER INDEX (Cont.)

Part No.	Description	Pg. No.	Ref. No.	Qty.	Part No.	Description	Pg. No.	Ref. No.	Qty.
63-7590	Relay	8	42	1	93-7822	Decal - Refueling	13	38	1
63-8360	Key	2	35	2	93-7823	Decal - Oil	6	51	1
65-5100	Handle	13	41	1	93-8069	Decal - Hot Surface	14	5	1
66-0120	Knob	1	26	2	93-8071	Decal - Hot Surface	5	32	1
66-1570	Frame - Lift	11	14	1	93-9475	Bracket - Hydraulic Lock	8	51	1
72-4060	Bearing Assembly	18	9	2	93-9476	Spacer - Latch	8	48	1
74-0110	Pedal - Traction	1	11	1	93-9478	Guard - Muffler	14	34	1
74-0720	Tube - Manual	8	41	1	94-1283	Control Block	8	20	1
75-4130	Spacer	19	27	2	94-1296	Hose - Carburetor	14	2	1
75-5470	Spacer Bearing	19	22	1	94-5848	Harness - Wire	16	*	1
75-6820	Meter - Hour	8	29	1	94-5849	Diode	16	*	1
76-8640	Stud - Traction	19	13	1	218-461	Nut - Lock	2	34	1
76-9430	Spring - Extension	18	19	1	231-122	Tire	4	9	2
76-9430	Spring - Extension (Ref.)	19	9		231-126	Tire	3	5	2
77-0981	Boot - Terminal	13	10	1	232-27	Valve Stem w/Cap	4	7	2
80-3750	Spacer	18	12	2	232-27	Valve Stem w/Cap	3	36	2
80-3760	Support - Seat, Front	8	2	1	233-37	Knob	11	3	1
80-4910	Footrest - R.H.	2	69	1	233-37	Knob	8	11	1
80-4920	Pedal - Accelerator	1	8	1	233-67	Knob	8	50	1
80-4930	Footrest - Pedal	1	6	1	237-42	"O"Ring	10	20	2
82-4640	Battery	13	12	1	237-42	"O"Ring	8	24	2
82-4680	Lever - Valve	8	10	1	237-42	"O"Ring	13	30	2
82-4720	Pad - Footrest	2	74	1	237-78	"O"Ring	11	17	2
88-3850	Wheel - Steering	2	29	1	237-78	"O"Ring	8	19	2
88-9830	Switch - Ignition	2	36	1	237-79	"O"Ring	19	7	2
92-5435	Support - Seat L.H.	8	32	1	237-79	"O"Ring	6	62	1
92-6250	Mount - Engine	5	10	1	237-80	"O"Ring	19	49	2
92-6251	Mount - Engine	5	12	1	237-100	Grommet	13	19	1
92-6252	Mount - Cylinder	6	47	1	242-50	Nut	4	6	8
92-6254	Bar - Tension	5	24	1	242-60	Rim	3	6	2
92-6255	Axle - Rear	3	10	1	242-71	Bolt - Wheel	4	1	8
92-6257	Plate - Pivot	3	24	1	242-76	Rim	4	8	2
92-6259	Bracket	8	43	1	2411-34	Ball Joint	1	16	1
92-6260	Duct - Engine	14	6	1	2411-34	Joint - Ball	19	30	1
92-6266	Panel - Tower Rear	2	37	1	2412-92	Clamp - Hose	14	3	2
92-6267	Shield - Heat	13	21	1	2412-93	Clamp - Hose	9	7	1
92-6269	Lever - Traction	19	28	2	2412-93	Clamp - Wire	8	47	1
92-6270	Plate - Traction	19	50	1	2412-100	JClamp	5	13	2
92-6273	Bracket - Spring	18	23	1	2412-100	"R"Clamp	13	22	1
92-6274	Plug - Cap	13	25	1	2412-108	Clamp - Hose	13	23	4
92-6276	Decal - Proline 120	13	37	2	2412-120	"R"Clamp	8	38	2
92-6280	Seat	9	1	1	251-210	Bearing - Ball	3	3	4
92-6281	Plate - Seat	8	12	1	251-288	Bearing w/Collar	18	24	2
92-6282	Switch - Seat	9	11	1	251-291	Bearing - Pulley	15	8	1
92-6283	Hose - Fuel	13	24	2	251-292	Bearing - Field	15	2	1
92-6284	Plate - Adapter, Seat	9	5	2	251-304	Rod End	3	33	2
92-6287	Wire - Ground	14	25	1	251-304	Rod End	2	57	1
92-6288	Decal - Service	13	40	1	251-304	Rod End	18	35	1
92-6289	Swing Arm Assembly	19	11		251-305	Rod End	3	25	3
92-6290	Spacer	19	20	1	251-305	Rod End	18	37	1
92-6292	Pad - Fender R.H.	5	2	1	251-307	Bearing	19	19	2
92-6293	Pad - Fender L.H.	5	38	1	251-341	Flange - Bearing	18	31	4
93-6696	Decal - Spring Load	11	43	1	256-154	Bushing	11	32	2
93-7272	Decal - Caution	5	7	2	256-156	Bushing	1	10	2
93-7281	Decal - Throttle Choke	2	32	1	283-17	Pin - Clevis	8	16	1
93-7284	Decal - Switch	2	40	1	283-55	Pin - Clevis	11	23	1
93-7296	Decal - Parking Brake	8	1	2	288-10	Cap - Pipe	14	28	1
93-7300	Decal - Lift Control	8	13	1	289-46	Nipple - Pipe	14	27	1
93-7306	Decal - Tunnel	2	47	1	302-2	Fitting - Grease	18	20	2
93-7331	Decal - Warning	11	29	2	302-5	Fitting - Grease	3	4	4

*Not Illustrated

TORO PART NUMBER INDEX (Cont.)

Part No.	Description	Pg. Ref. No. No. Qty.	Part No.	Description	Pg. Ref. No. No. Qty.
302-22	Fitting - Grease	1 13 1	3220-4	Nut - Jam	3 28 3
302-49	Fitting - Grease	3 21 3	3220-6	Nut - Jam	11 12 2
302-49	Fitting - Grease	18 25 1	3220-19	Nut - Jam	3 34 2
302-60	Fitting - Grease 90°	19 10	3229-1	Bolt - Carriage	13 11 4
321-2	Screw	11 36 2	3230-1	Bolt - Carriage	18 30 6
321-2	Screw - Hex. Hd.	1 27 4	3230-3	Bolt - Carriage	14 20 1
321-2	Screw - Hex. Hd.	19 43 1	3234-1	Screw - Hex. Flange Hd.	18 14 5
321-3	Screw	6 49 2	3234-14	Screw	5 3 4
321-3	Screw - Hex. Hd.	1 9 2	3241-1	Screw - Set	18 2 4
321-3	Screw - Hex. Hd.	13 1 2	3241-2	Screw - Set	19 37 2
321-4	Screw	9 10 2	3245-35	Screw - Set	18 8 4
321-4	Screw	3 15 4	3250-46	Screw	19 33 2
321-4	Screw	8 36 5	3253-3	Washer	11 37 2
321-4	Screw - Hex. Hd.	2 61 14	3253-3	Washer - Lock	19 42 1
321-14	Screw	5 16 2	3253-3	Washer - Lock	6 50 2
321-23	Screw	8 9 2	3253-4	Washer - Lock	14 8 1
321-23	Screw - Hex. Hd.	8 7 1	3253-5	Washer - Lock	19 39 4
322-2	Screw	5 30 4	3253-5	Washer - Lock	19 48 4
322-3	Screw - Hex. Hd.	13 5 2	3253-6	Washer - Lock	14 11 2
322-4	Screw	9 4 4	3253-7	Washer	3 39 2
322-4	Screw	8 6 12	3254-5	Washer - Lock	2 33 1
322-4	Screw	5 26 13	3254-6	Washer - Lock, Int. Tooth	14 24 1
322-4	Screw	11 33 4	3255-5	Washer - Lock	19 45 3
322-4	Screw - Hex. Hd.	1 2 19	3255-8	Washer - Lock, Ext. Tooth	6 69 1
322-4	Screw - Hex. Hd.	18 18 6	3256-1	Washer	13 13 4
322-4	Screw - Hex. Hd.	18 5 6	3256-1	Washer	11 38 2
322-4	Screw - Hex. Hd.	13 17 2	3256-1	Washer - Flat	8 25 10
322-5	Screw	9 6 4	3256-3	Washer - Flat	18 7 6
322-5	Screw	14 32 2	3256-3	Washer - Flat	6 54 2
322-6	Screw	5 9 8	3256-4	Washer - Flat	3 26 7
322-6	Screw	11 11 2	3256-4	Washer - Flat	2 56 1
322-6	Screw	5 23 11	3256-22	Washer - Flat	8 49 2
322-6	Screw - Hex. Hd.	19 15 2	3256-23	Washer	14 33 2
322-7	Screw - Hex. Hd.	19 17 1	3256-23	Washer - Flat	5 4 8
322-10	Screw	4 5 2	3256-23	Washer - Flat	8 5 6
322-10	Screw - Hex. Hd.	2 67 2	3256-23	Washer - Flat	2 49 4
322-10	Screw - Hex. Hd.	18 11 4	3256-24	Washer - Flat	11 4 2
323-7	Screw	5 20 3	3256-39	Washer	3 40 1
323-8	Screw - Hex. Hd.	18 10 4	3256-51	Washer	8 39 2
323-9	Screw	14 30 2	3256-55	Washer	19 41 1
323-9	Screw	6 57 2	3256-68	Washer	19 8 2
323-10	Screw	11 25 1	3257-5	Key - Woodruff	18 26 3
323-10	Screw - Hex. Hd.	14 22 1	3257-5	Key - Woodruff	19 36 3
323-11	Screw	5 42 2	3257-10	Key - Woodruff	4 3 2
323-12	Screw - Hex. Hd.	14 23 1	3257-24	Key - Woodruff	19 5 1
323-13	Screw - Hex. Hd.	19 46 1	3258-19	Screw - Round Hd.	7 7 2
323-14	Screw - Hex. Hd.	19 34 1	3272-6	Pin - Cotter	8 15 1
323-16	Screw - Hex. Hd.	19 47 1	3272-10	Pin - Cotter	11 5 2
324-7	Screw	3 27 5	3272-12	Pin - Cotter	3 37 2
324-7	Screw - Hex. Hd.	2 58 1	3290-211	Washer - Spring	5 29 2
324-7	Screw - Hex. Hd.	18 36 2	3290-250	Pin - Cotter	5 15 2
324-11	Screw - Hex. Hd.	14 12 1	3290-355	Pin - Cotter	11 24 1
325-6	Screw	3 38 2	3290-357	Nut - Wizz	14 31 1
327-24	Screw	6 48 1	3290-379	Cable Tie	6 66 7
3212-24	Screw - Hex. Hd.	14 15 1	3290-440	Washer - Belleville	2 42 1
3217-6	Nut	19 16 4	3296-3	Nut - Hex.	1 15 1
3217-6	Nut - Square	14 7 1	3296-3	Nut - Lock	19 32 1
3220-1	Nut - Hex. Jam	19 31 1	3296-6	Nut	11 35 1
3220-1	Nut - Jam	1 17 1	3296-6	Nut - Lock	15 9 3
3220-4	Nut - Hex. Jam	18 38 2	3296-9	Nut	19 25 2

*Not Illustrated

TORO PART NUMBER INDEX (Cont.)

Part No.	Description	Pg. Ref. No. No. Qty.	Part No.	Description	Pg. Ref. No. No. Qty.
3296-15	Nut	11 41 2	32107-11	Nut - Square	7 8 2
3296-25	Nut	19 29 1	32115-5	Nut - Square	2 60 4
3296-29	Nut	8 4 12	32120-64	Ring - Snap	19 1 1
3296-29	Nut	11 7 6	32121-10	Pin - Roll	1 28 1
3296-29	Nut	5 14 33	32121-20	Pin - Roll	1 19 1
3296-29	Nut	3 16 8	32121-31	Pin - Roll	1 20 2
3296-29	Nut	14 35 2	32121-51	Pin - Roll	1 7 1
3296-29	Nut - Hex.	13 7 9	32121-51	Pin - Roll	3 30 1
3296-29	Nut - Lock	18 4A/R	32121-77	Pin Roll	2 59 2
3296-29	Nut - Lock	4 4 2	32128-20	Nut - Flange Lock	2 48 2
3296-29	Nut - Lock	9 8 8	32128-20	Nut - Flange Lock	6 67 1
3296-29	Nut - Lock	19 14A/R	32144-1	Screw - Thread Forming	11 10 2
3296-29	Nut - Lock	1 18 24	32144-11	Screw - Thread Forming	5 5 2
3296-39	Nut	8 37 1	32144-15	Screw	3 18 2
3296-39	Nut - Lock	14 26 2	32144-18	Screw	8 45 2
3296-41	Nut - Hex.	3 12 1	32144-19	Screw - Round Hd.	19 44 3
3296-42	Nut - Lock	6 65 2	32149-1	Nut - Lock	5 27 1
3296-42	Nut - Lock	13 14 8	32149-1	Nut - Lock	18 32 6
3296-42	Nut - Lock	8 21 18	32151-48	Ring - Retaining	3 11 2
3296-42	Nut - Lock	1 23 16	32152-10	Nut - Lock	12 2 1
3296-44	Nut	11 28 1	32153-3	Nut	11 15 2
3296-44	Nut	5 17 4	353-370	Fitting - Hydraulic 90°	19 6 2
3296-44	Nut - Lock	18 6 4	353-371	Fitting - 90°	6 61 2
3296-48	Nut	3 23 5	353-375	Fitting - 90°	11 19 1
3296-48	Nut - Lock	18 39 2	353-375	Fitting - 90°	8 22 1
3296-48	Nut - Lock	2 55 1	353-385	Fitting - Hydraulic Straight	13 29 2
3296-56	Nut - Lock	8 52 1	353-431	Fitting - 45°	11 16 1
3296-61	Nut	6 46 1	353-511	Fitting	8 17 2
32103-22	Nut - Wing	13 8 3	353-511	Fitting - Hydraulic 90°	19 35 2
32104-76	Screw	8 40 4	353-545	Fitting	8 18 1

PRODUCT CHANGES

In an effort to make improvements available to TORO owners as quickly as possible, minor changes are incorporated into Toro's products from time to time that do not become immediately shown in the Parts Catalog. If such a change has been made in your unit, which is not reflected in your manual, see your TORO Distributor or his Authorized TORO Service Dealer for information and part numbers.

IDENTIFICATION AND ORDERING

MODEL AND SERIAL NUMBERS

The ProLine 120 has two identification numbers; a model number and a serial number. The two numbers are stamped on a plate which is located on the main frame under the seat. In any correspondence concerning the ProLine 120, supply model and serial numbers to assure that correct information and replacement parts are obtained.

To order replacement parts from an Authorized TORO Service Dealer, supply the following information:

1. Model and serial number of the ProLine 120.
2. Part number, description, and the quantity of part(s) desired.

NOTE: Do not order by reference number if a parts catalog is being used; use the PART NUMBER.

TABLE OF CONTENTS

Description	Page	Description	Page
Frame And Steering Assembly	1	Transmission Assembly	19
Rear Axle Assembly	3	Hydrostatic Transmission Assembly	20
Front Wheel Assembly	4	Differential Assembly	22
Frame And Jackshaft Assembly	5	Engine Kohler Model CH20QS Spec 64556	
Air Cleaner Assembly	7	Baffles & Shroud	24
Seat Support Assembly	8	Oil Pan/Lubrication	25
Seat Assembly	9	Crankcase	26
Valve Assembly No.54—0090	10	Cylinder Head, Valve & Breather	27
Parking Brake & Frame Assembly	11	Crankshaft, Piston & Rings	28
Hydraulic Lift Cylinder No. 54—0150	12	Carburetor And Fuel Pump	29
Hood, Fuel Tank & Hydraulic Reservoir Assembly	13	Air Intake / Filtration	30
Engine Assembly	14	Throttle Linkage & Governor Control	31
Clutch Assembly No. 54—0220	15	Starter	32
Electric Schematic	16	Ignition And Charging System	33
Hydraulic Schematic	17	Exhaust	34
Differential Assembly	18	Numeric Index, Toro P/N Only	35

Optional equipment

Description	Model No./Part No.	Description	Model No./Part No.
Flotation Kit	30759	44" Grass Collection System	30751
44" Deck Baffle Kit	60—9030	52" Grass Collection System	30576
52" Deck Baffle Kit	68—7210	44" Recycler Kit	59220
44" Leaf Mulcher Deck	30752	52" Recycler Kit	59225
52" Leaf Mulcher Deck	30700	Brake Kit	30758
Wheel Weight Kit	56—6620	Tire Chain Kit	56—6630
44" Snowthrower	30761	Rear Weight	62—6590
44" Side Discharge Deck	30544	Cab Kit	
48" Rear Discharge Deck	30747	European Complacence Parts Kit	93—9450
52" Side Discharge Deck	30753		